

Service Manual

Speaker

SB-5000/SB-6000



SB-5000

SB-6000

■ SPECIFICATIONS

SB-5000

Type:	2-way, 2-speaker bass-reflex system
Speakers:	Woofer: 25cm (10") cone type Tweeter: 6cm (2-3/8") cone type
Impedance:	8 ohms
Peak input power:	75 watts
Output sound pressure level:	93.5 dB/w (at 1.0m)
Crossover frequency:	2000 Hz
Dimensions:	35.0 (W) x 71.7 (H) x 32.3 (D) cm 13-3/4" (W) x 28-1/4" (H) x 12-11/16" (D)
Weight:	16.0 kg (35.2 lbs)
Accessory:	Speaker cord 3 m ... 1

SB-6000

Type:	2-way, 2-speaker bass-reflex system
Speakers:	Woofer: 30 cm (12") cone type Tweeter: 3.2 cm (1-1/4") dome type
Impedance:	6 ohms
Peak input power:	100 watts
Output sound pressure level:	93 dB/w (at 1.0m)
Crossover frequency:	1500 Hz
Dimensions:	42.5 (W) x 84.6 (H) x 34.0 (D) cm 16-3/4" (W) x 33-5/16" (H) x 13-3/8" (D)
Weight:	28.0 kg (61.7 lbs)
Accessory:	Speaker cord 3m ... 1

■ SCHEMATIC DIAGRAM

SB-5000

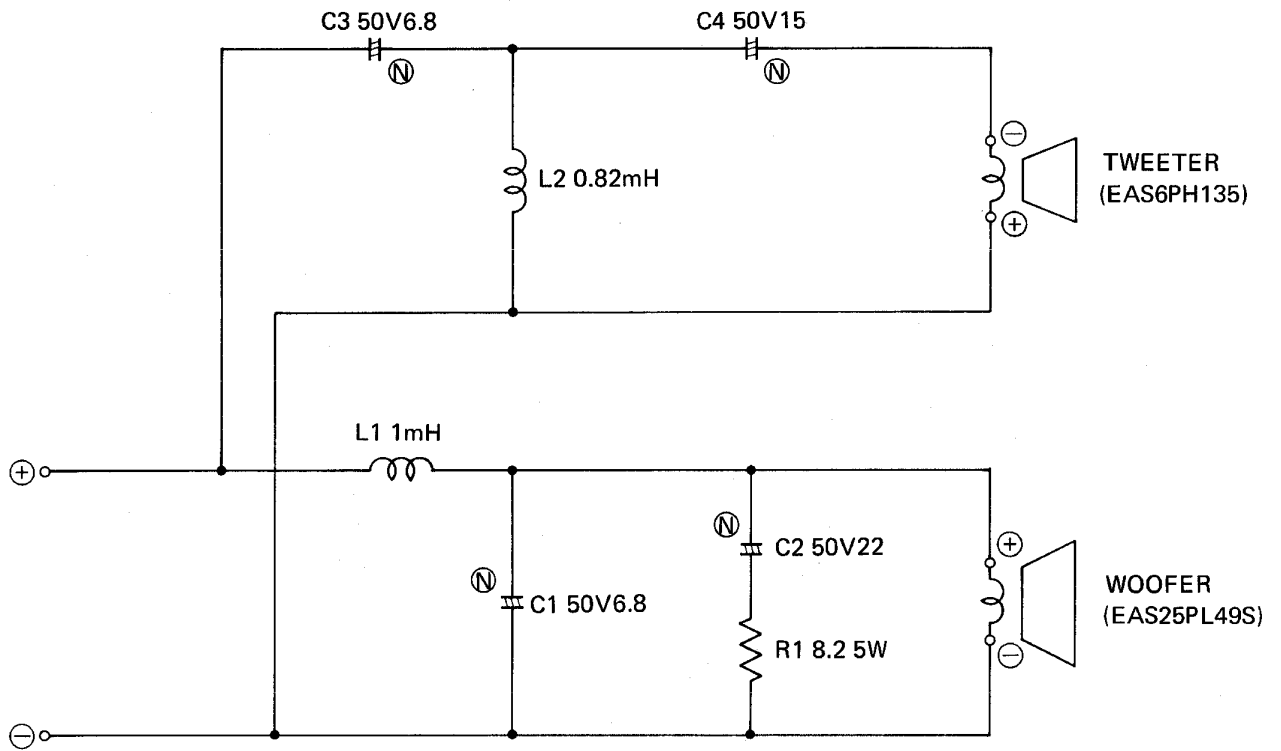

SB-6000

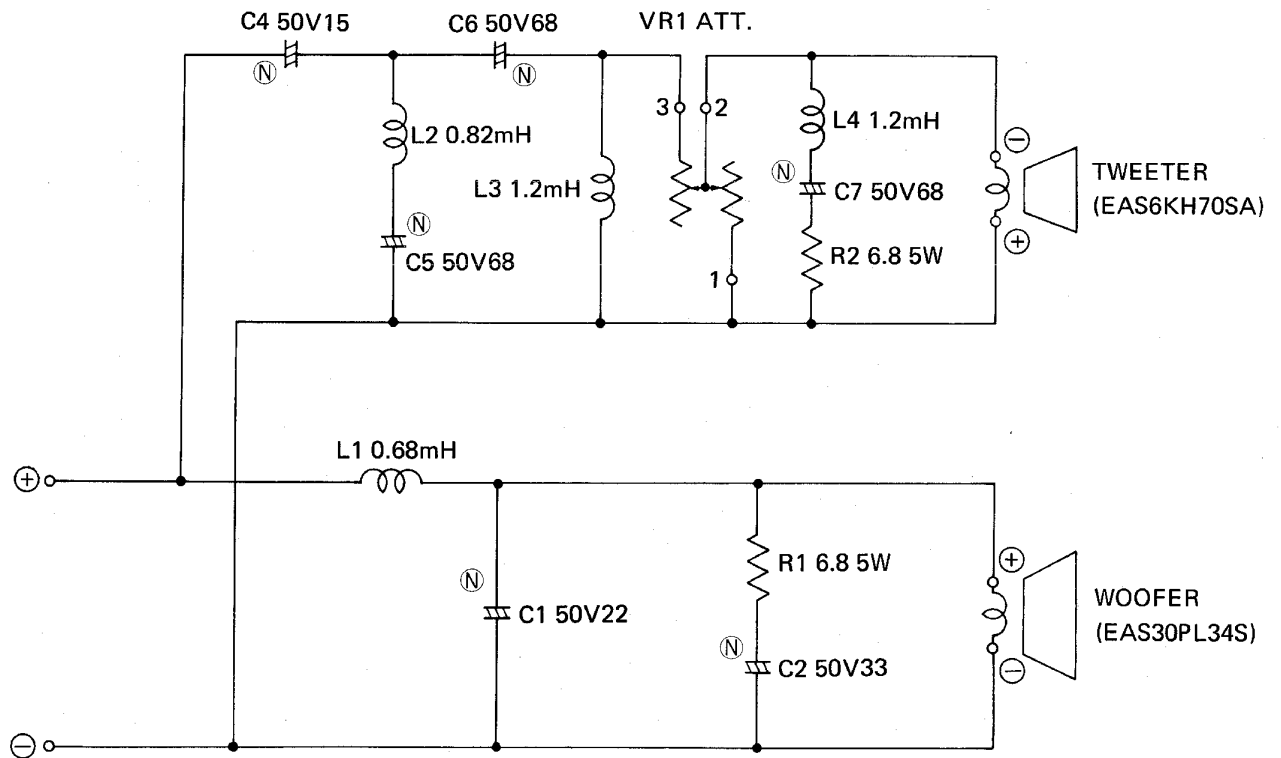

■ CIRCUIT BOARD

SB-5000

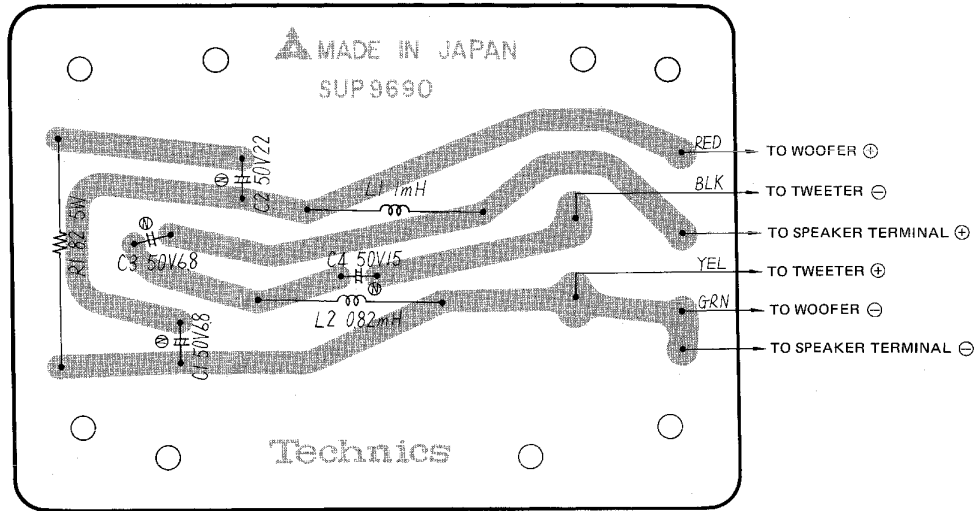

SB-6000

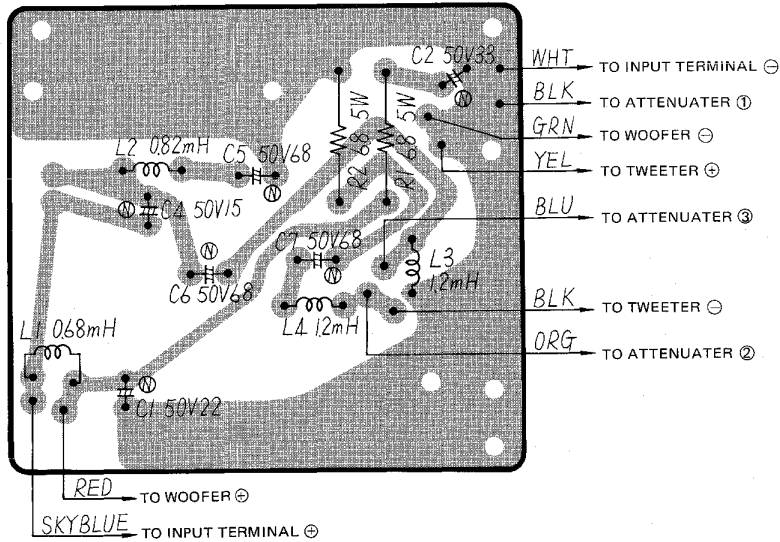

■ LOCATION OF PARTS

SB-5000

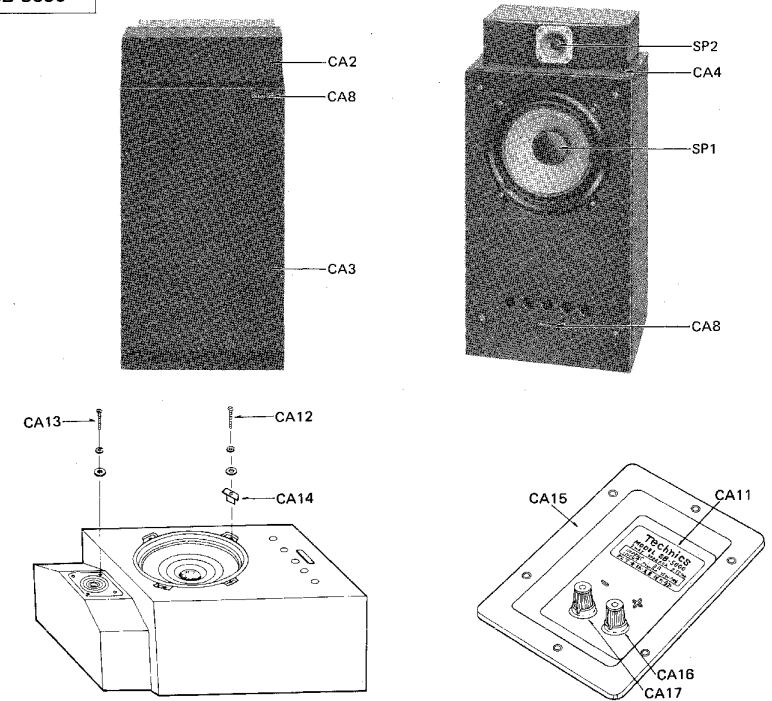

SB-6000

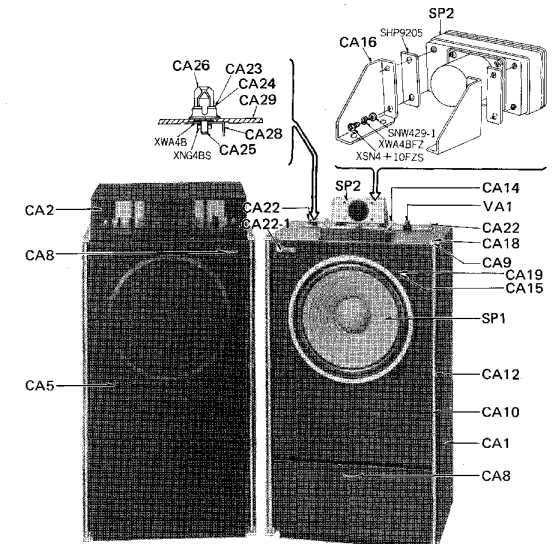

Service Manual

Linear Phase Speaker System

SB-5000/SB-6000

Supplement-1

PARTS MODIFICATION ON TWEETER PROTECTION

For additional information, please refer to the service manual for Model No. SB-5000,SB-6000.

- Notes:
- * This service manual includes only the changes of the **SB-5000,SB-6000** service manual (ORDER NO.SD7601-1052).
 - * When servicing model **SB-5000,SB-6000** this service manual and **SB-5000,SB-6000** (ORDER NO. SD7601-1052) service manual should be used together.

CHANGES

■ REPLACEMENT PARTS LIST

SB-5000

Ref. No.	Change of Part No.		Part Name & Description	Per Set (Pcs.)	Remarks
	OLD	NEW			
F1	Addition	XBA1E06NS5	600mA, Fuse	1	
C3	ECEA50Y6R8	ECEA100Y4R7	4.7 μ F, 100V, Electrolytic	1	
C5	Addition	ECEA50Y2R2	2.2 μ F, 50V, Electrolytic	1	
CA1	SKA8036	SKA9811W	Cabinet	1	
CA18	Addition	QTF1046	Fuse Holder	1	
CA19	Addition	SMK31	Fuse Panel	1	
CA20	Addition	SHR9359	Rubber	1	
CA21	Addition	XMS31 + 10FZ	Screw	3	
	Addition	SQX4561	Caution Label	1	

SB-6000

Ref. No.	Chang of Part No.		Part Name & Description	Per Set (Pcs.)	Remarks
	OLD	NEW			
F1	Addition	XBA1E10NS5	1A, Fuse	1	
C4	ECEA50Y15	ECEA50Y10	10 μ F, 50V, Electrolytic	1	
C8	Addition	ECEA50Y3R3	3.3 μ F, 50V, Electrolytic	1	
CA1	SKA8073	SKA9832W	Cabinet	1	
CA30	Addition	QTF1046	Fuse Holder	1	
CA31	Addition	SMK31	Fuse Panel	1	
CA32	Addition	SHR9359	Rubber	1	
CA33	Addition	XMS31 + 10FZ	Screw	3	
	Addition	SQX4565	Caution Label	1	