

# Service Manual

## Speaker System SB-CA01A

### Hi-Fi Speaker System

Colour

(M).....Brown Type



#### ■ SPECIFICATIONS

Type	2-way 2-speaker system
Speakers	Woofer: 12 cm cone type Tweeter: 2.5 cm dome type
Impedance	6 Ω
Input Power	100 W (Music) 50 W (DIN)
Output Sound Pressure Level	86 dB/W (1.0 m)
Crossover Frequency	3.5 kHz
Frequency Range	40 Hz ≈ 40 kHz (-16 dB) 45 Hz ≈ 36 kHz (-10 dB)
Dimensions (W x H x D)	200 x 336 x 219 mm
Weight	4.4 kg

Note:

Design and specifications are subject to change without notice.

#### ■ ESPECIFICACIONES

Tipo	Sistema de 2 vías con 2 altavoces
Altavoces	Graves: tipo cónico de 12 cm Agudos: tipo cúpula de 2,5 cm
Impedancia	6 Ω
Capacidad de potencia	100 W (Musicales) 50 W (DIN)
Nivel de presión acústica de salida	86 dB/W (1,0 m)
Frecuencia de cruce	3,5 kHz
Respuesta de frecuencias	40 Hz ≈ 40 kHz (-16 dB) 45 Hz ≈ 36 kHz (-10 dB)
Dimensiones (W x H x D)	200 x 336 x 219 mm
Peso	4,4 kg

Nota:

Estas especificaciones están sujetas a cualquier cambio sin previo aviso.

#### ■ SPECIFICATIONS

Type	2-voies 2-haut-parleurs
Haut-parleurs	Graves: 12 cm type a cone Aigus: 2,5 cm type dome
Impédance	6 Ω
Entrée maximale	100 W (Musique) 50 W (DIN)
Niveau de pression sonore de sortie	86 dB/W (1,0 m)
Fréquence de commutation	3,5 kHz
Gamme de fréquences	40 Hz ≈ 40 kHz (-16 dB) 45 Hz ≈ 36 kHz (-10 dB)
Dimensions (W x H x D)	200 x 336 x 219 mm
Poids	4,4 kg

Note:

Sujet à changement sans preavis.

#### ⚠ WARNING

This service information is designed for experienced repair technicians only and is not designed for use by the general public. It does not contain warnings or cautions to advise non technical individuals of potential dangers in attempting to service product. Products powered by electricity should be serviced or repaired only by experienced professional technicians. Any attempt to service or repair the product or products dealt with in this service information by anyone else could result in serious injury or death.

# Technics®

© 1996 Panasonic Spain S.A.  
All rights reserved. Unauthorized copying  
and distribution is a violation of law.

# DISASSEMBLY INSTRUCTIONS

Ref. No. 1  
Removal of the Speaker Net  
Procededure 1

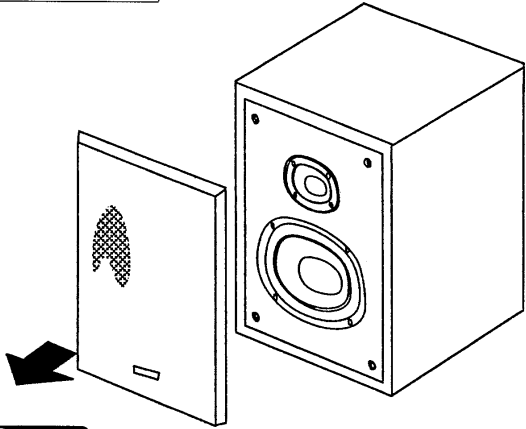

**Step 1**

- Remove the Speaker Net in the direction of arrow.

Ref. No. 2  
Removal of the Speaker Tweeter  
Procededure 1 → 2

**Step 1**

- Remove the 4 screws.

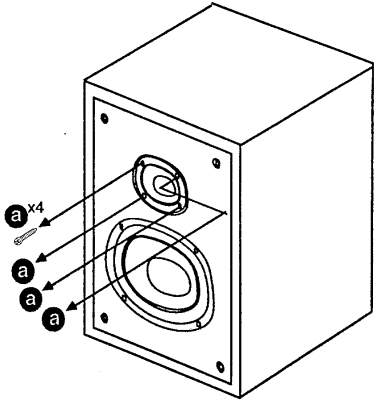

**Step 2**

- Remove the Speaker Tweeter in the direction of front part.

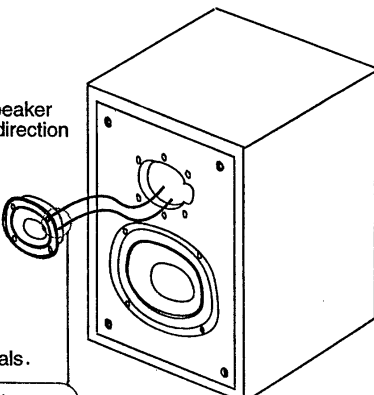

**Step 3**

- Remove the 2 Speaker terminals.

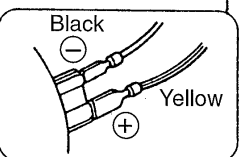
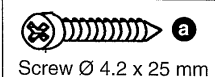
Ref. No. 3  
Removal of the Speaker Woofer  
Procededure 1 → 3

**Step 1**

- Remove the 4 screws.

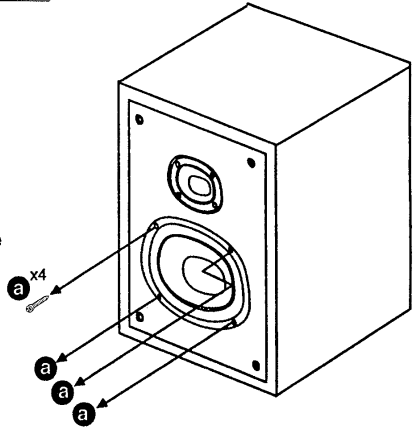

**Step 2**

- Remove the Orment Woofer in the direction of front part.

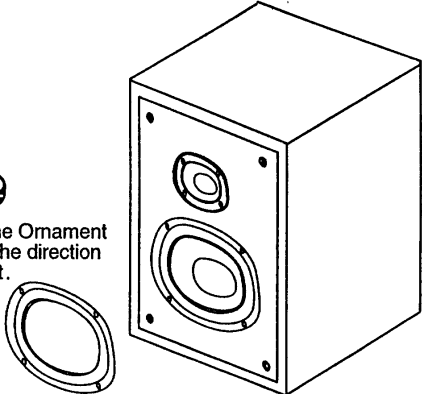

**Step 3**

- Remove the Speaker Woofer in the direction of front part.

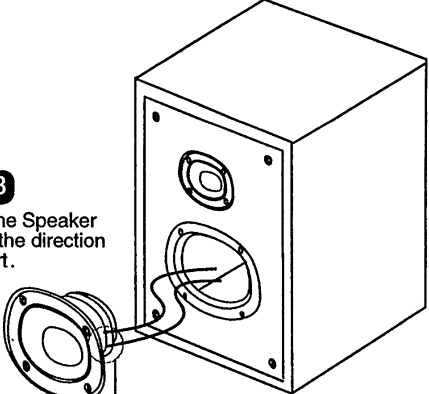

**Step 4**

- Remove the 2 Speaker terminals.

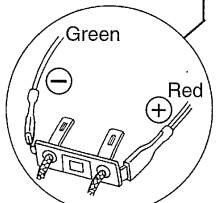
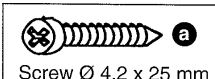



Ref. No. 4      Removal of the Bass Reflex

Procededure 4

**Step 1**

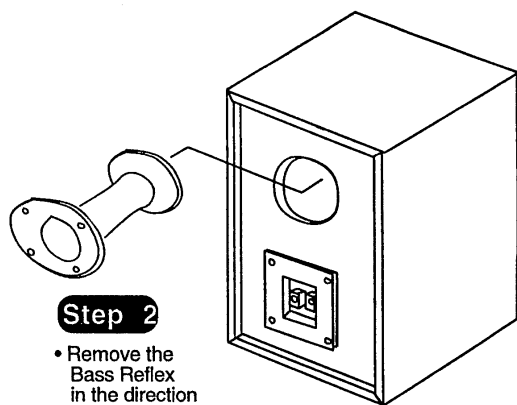
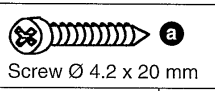
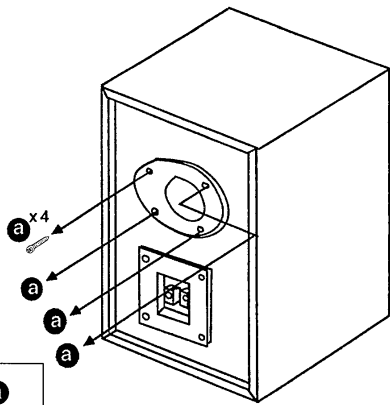
- Remove the 4 screws.



**Step 2**

- Remove the Bass Reflex in the direction of front part.

Ref. No. 5      Removal of the Terminal Block

Procededure 5

**Step 1**

- Remove the 4 screws.

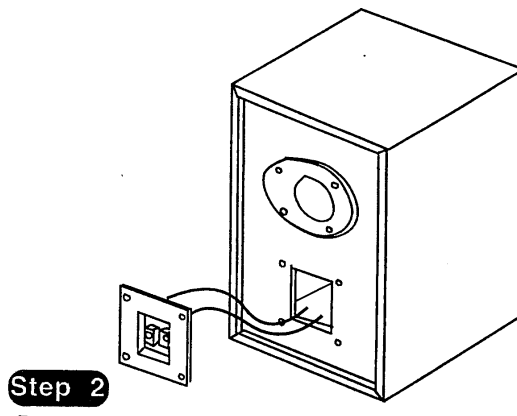
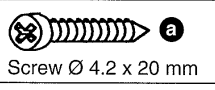
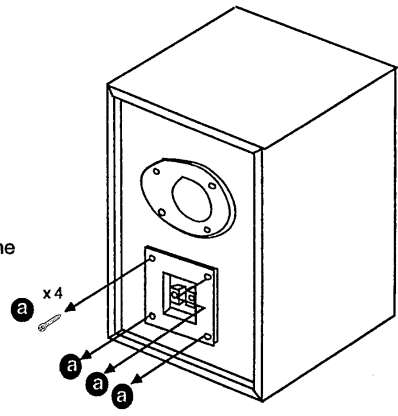

**Step 2**

- Remove the Terminal Block in the direction of front part

**SCHEMATIC DIAGRAM**

(This schematic diagram may be modified at any time with development of new technology.)  
 (Este esquema puede ser modificado en cualquier momento con el desarrollo de nuevas tecnologías.)

⊗ (N) NON-POLAR CAPACITOR

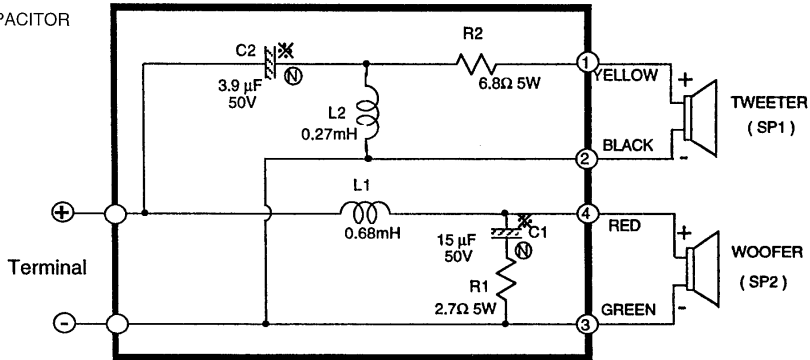

## REPLACEMENT PARTS LIST

Notes 1. Part numbers are indicated on most mechanical parts. Please use this part number for parts orders.

2. **PAES** indicates parts that are supplied by PAES.

3. **AD** indicates parts that are supplied by AD. M.E.I.

Notas 1. El código está indicado en la mayoría de las piezas. Por favor, use este código para sus pedidos.

2. La indicación **PAES** significa recambios suministrados a través de PAES.

3. La indicación **AD** significa recambios suministrados a través de AD. M.E.I.

Ref. No.	Part No.	Part Name & Description	Remarks
		SPEAKER (S)	
SP1	EAS25KH330A6	SPEAKER (TWEETER)	PAES
SP2	EAS12PL339A6	SPEAKER (WOOFER)	PAES
		COIL (S)	
L1	SLCP681J	CHOQUE COIL 0.68 mH	PAES
L2	SLCP271J	CHOQUE COIL 0.27 mH	PAES
		CAPACITOR (S)	
C1	ECEA50YT15KE	NON-POLAR CAPACITOR 15µF 50V	PAES
C2	ECEA50YT3R9KE	NON-POLAR CAPACITOR 3.9µF 50V	PAES
		RESISTOR (S)	
R1	ERF5ZXK2R7	RESISTOR 2.7Ω 5W	AD
R2	ERF5ZXK6R8	RESISTOR 6.8Ω 5W	AD

Ref. No.	Part No.	Part Name & Description	Remarks
		CABINET PARTS	
1	SYMPCA01AM	CABINET ASS'Y	PAES
2	SYBPCA01A	NET FRAME	PAES
3	SWEPCA01A	TERMINAL ASS'Y	PAES
4	SGES8G187-1	BASS REFLEX	PAES
5	RGKP0848-K	ORNAMENT WOOFER	PAES
6	SHG8G9044	NET HOLDER	PAES
7	RKA8G0066-K	LEG	PAES
		SCREW (S)	
N1	XTNP42+25FG	SCREW SPEAKER TWEETER	PAES
N2	XTN42+25FG	SCREW SPEAKER WOOFER	PAES
N3	XTN42+20FG	SCREW BASS REFLEX	PAES
N3	XTN42+20FG	SCREW TERMINAL BLOCK	PAES
N4	XTBS42BZ+8	SCREW P.C.B.	PAES
		PACKING PARTS	
P1	SPGPCA01AM	CARTON BOX	PAES
P2	SPS8GBCH700	PAD	PAES
P3	SPH8G415	SHEET	PAES

## EXPLODED VIEW

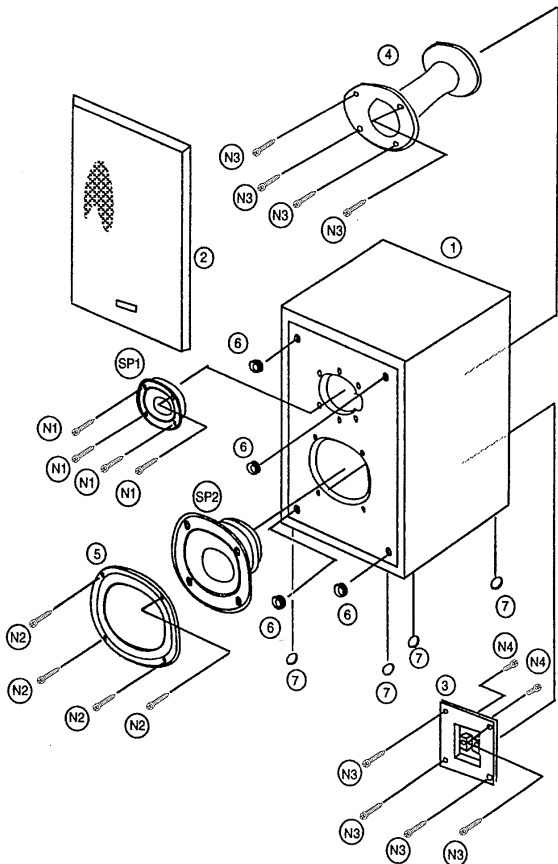

## PACKAGING

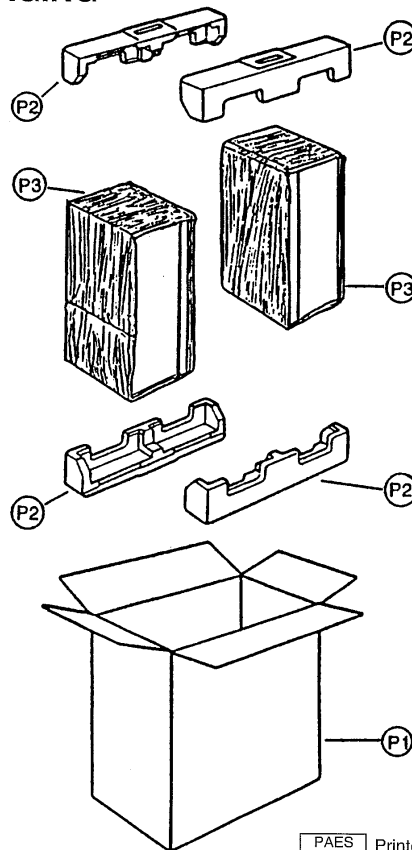

PAES Printed in Spain  
A960409000JS