

# Service Manual

SB-E200

Linear Phase Speaker System

## SB-E200

(XG),(XGE),(XGF)

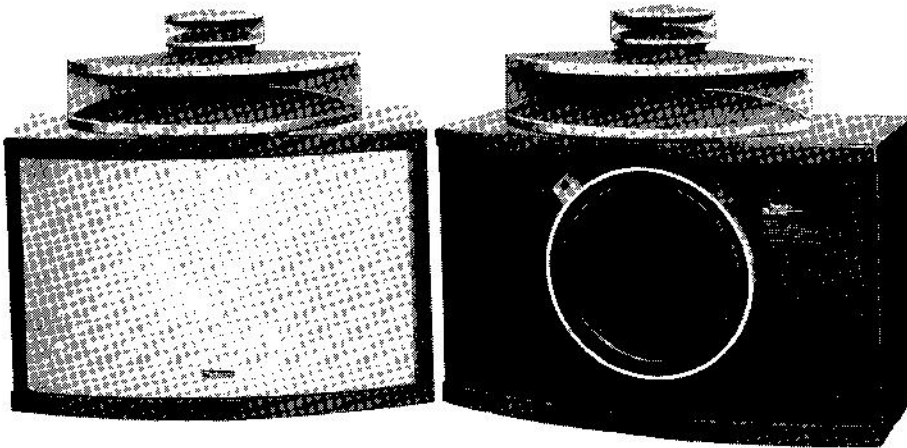

- \* The model SB-E200 (XG) is available in European only.
- \* The model SB-E200 (XGE) is available in England only.
- \* The model SB-E200 (XGF) is available in France only.

### ■ SPECIFICATIONS

(Specifications are subject to change without notice for further improvement.)

<b>Type:</b> 3 way, 3-speaker system <b>Speakers:</b> Woofer: 30cm (12") cone type Midrange: Horn type Tweeter: Horn type <b>Impedance:</b> 6 ohms <b>Input power:</b> 150W, Music 100W, DIN (RMS)	<b>Output sound-pressure level:</b> 94dB/W (at 1.0m) <b>Crossover Frequency:</b> 1500Hz, 6500Hz <b>Frequency Range:</b> 37~22000Hz <b>Dimensions:</b> 63.3(W)×61.8(H)×44.1(D) cm 24-7/8"(W)×24 3/8"(H)×17-3/8"(D) <b>Weight:</b> 27.5kg (60.6 lbs)
--	---

### ■ TECHNISCHE DATEN

(Spezifikationen können infolge von Verbesserungen ohne Ankündigung geändert werden.)

<b>Typ:</b> System mit 3 Lautsprechern und 3 Bereichen <b>Lautsprecher:</b> 30-cm-Tiefenlautsprecher Konusstyp <b>Impedanz:</b> 6 ohm <b>Spitzenbelastbarkeit:</b> 150W, Music: 100W, DIN(RMS) <b>Abgegebener schalldruckpegel:</b> 94dB/W (im Abstand von 1m) <b>Überschneidungsfrequenz:</b> 1500Hz, 6500Hz <b>Frequenzumfang:</b> 37~22000Hz <b>Abmessungen:</b> 63.3(B)×61.8(H)×44.1(T) cm 24-7/8"(B)×24-3/8"(H)×17 3/8"(T) <b>Gewicht:</b> 27.5kg (60.6 lbs)
--

### ■ CARACTERISTIQUES TECHNIQUES

(Sujet à changement sans préavis.)

<b>Type:</b> Système à 3 hauts-parleurs et 3 canaux <b>Hauts-parleurs:</b> Woofer: 30cm à cône <b>Impédance:</b> 6 ohms <b>Entrée maximale instantanée:</b> 150W, Music: 100W, DIN(RMS) <b>Pression du niveau sonore de sortie:</b> 94dB/W (à 1m) <b>Fréquence de commutation:</b> 1500Hz, 6500Hz <b>Gamme de fréquences:</b> 37~22000Hz <b>Dimensions:</b> 63.3(L)×61.8(H)×44.1(P) cm 24 7/8"(L) ×24 3/8"(H)×17 3/8"(P) <b>Poids:</b> 27.5kg (60.6 lbs)
---

## Technics

Matsushita Electric Trading Co., Ltd.  
 P.O. Box 288, Central Osaka Japan

**■ FEATURES****• High efficiency, high input resisting 30cm woofer**

In order to make the most of the horn type speaker system, the woofer is required to be highly efficient and to have a frequency characteristic to go smoothly with the mid-range. In this respect, the system uses Canadian coniferous pulp and cones with liner elements combined, thus assuring a high efficiency of 95dB/W(1.0m). Also, to improve the linearity coping with a large input, well-ventilated high compliance dampers and non-directional urethane edges are employed. Furthermore, polyester insulator and polyamide layers are used for the voice coils, and extra-high heat resisting resin film is used for the bobbins so that the system is able to withstand continuous since waves of as high as 100 Watts (DIN RMS).

**• Wide-directional radial horn mid-range**

Frequency characteristics with wide-band and excellent directivity are obtained with a radial horn widening at 150 deg. from aluminum die-cast horn throat and newly developed shell type equalizer (mid-range). The driver section is made of extra-thin aluminum alloy of 35 $\mu$ m thick, and the edge, provided with slits, employs perforated pole pieces to improve the low-range characteristic, and is high input resisting with heat radiating aluminum bobbin of  $\mu$ m, CCAW (copper coated aluminum wire), and heat resisting voice coils.

**• Wide-directional radial horn tweeter**

This wide-directional radial horn, widening at 150 deg., is of high precision solid type made of aluminum diecast. The driver section consists of metalized polyester film vibrating reeds and employs a powerful magnetic circuit using a large aluminum magnet, and is high input resisting with use of heat resisting voice coils.

**• Linear phase network**

Linear phase characteristics are obtained by a dividing network combining 12 dB/oct and inductive M types, thus making reliable transfer of waves possible.

Also, low-distortion filament cores are employed for choke coils.

**• Control tower**

It is equipped with a thermal relay protection circuit in order to protect the mid-range and tweeter from excess input or abnormal signals. Also, to use it as a multiamp system, it is provided with multi-amp input terminal along with a multi-amp switching connector. Besides these functions, dividing network, level control and input terminal are concentrated at the control tower which also serves to secure drivers of the mid-range and tweeter, thus improving the controllability.

**■ POWER HANDLING CAPACITY**

The power handling capacity of this speaker system is 150 watts (music), and 100 watts DIN (RMS).

If the following special types of signals are applied to the speaker system, be sure to reduce the volume level of the amplifier.

1. Interstation hiss on the FM broadcast band.
2. Output from a tape deck during fast forward or rewind.
3. Acoustic feedback from a microphone or an electric musical instrument.
4. "Shock" noise which occurs when the power switch of amplifier, etc, is turned on or off, when input or output connection cords are connected or disconnected, or when a phono cartridge is replaced.

Use the speaker system with care to avoid damage by any of the above.

- Keep the speaker system away from heating appliances or other sources of heat, and do not expose it to direct sunlight or excessive moisture.
- Do not install the speaker system near a TV set, because the image of the TV set may be disturbed by the magnets used in this speaker unit.
- Never use a chemically-treated cloth, alcohol, thinner, benzine, insecticide or other volatile chemicals to clean the cabinet because to do so may damage the luster of its fine finish.

## ■ LOCATION OF CONTROLS

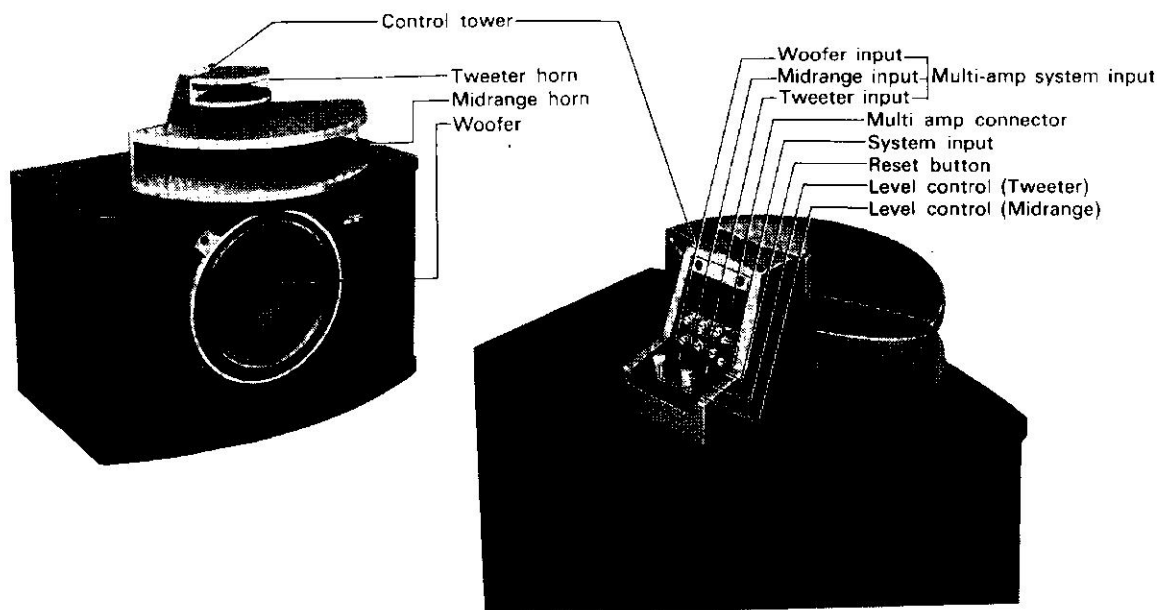

## ■ MULTI-AMP SYSTEM

- The impedance of each unit of woofer, midrange, and tweeter is  $6\Omega$ . Therefore, make sure that the load impedance of the amp used ranges from  $4\Omega$  to  $16\Omega$ .
- When the multi-amp switching connector is set to "multi amp system", the network, level control and protection circuit of this system are disconnected. The sound volume of each unit can be adjusted by turning the volume knob of each amp.
- It is recommended to use the system with crossover frequencies between speakers as follows:
 

Woofer – Midrange:	1.2kHz ~ 2kHz
Midrange – Tweeter:	5kHz ~ 10kHz
- In order to protect the speaker unit against low-range noise from the amp, connect a bipolar condenser of about  $68\mu\text{F}$  between amp and speaker, and about  $10\mu\text{F}$  to tweeter respectively in series.

## ■ SPEAKER PROTECTION CIRCUIT

This system is equipped with a speaker protection circuit to protect the speaker from excess input or abnormal signals. If excess input is applied to the speaker, it will be automatically cut off by the protection circuit.

- **When the tweeter or midrange stops producing sounds (treble or mean) during playing:**
  1. Turn down the volume of the amp,
  2. Check for abnormality in the system,
  3. If the system is normal, wait for 20 sec.,
  4. And then push the reset button to cancel the protection circuit.
- After resetting the protection circuit, do not increase the volume of the amp.

■ SCHEMATIC DIAGRAM

This schematic diagram may be modified at any time with the development of new technology.

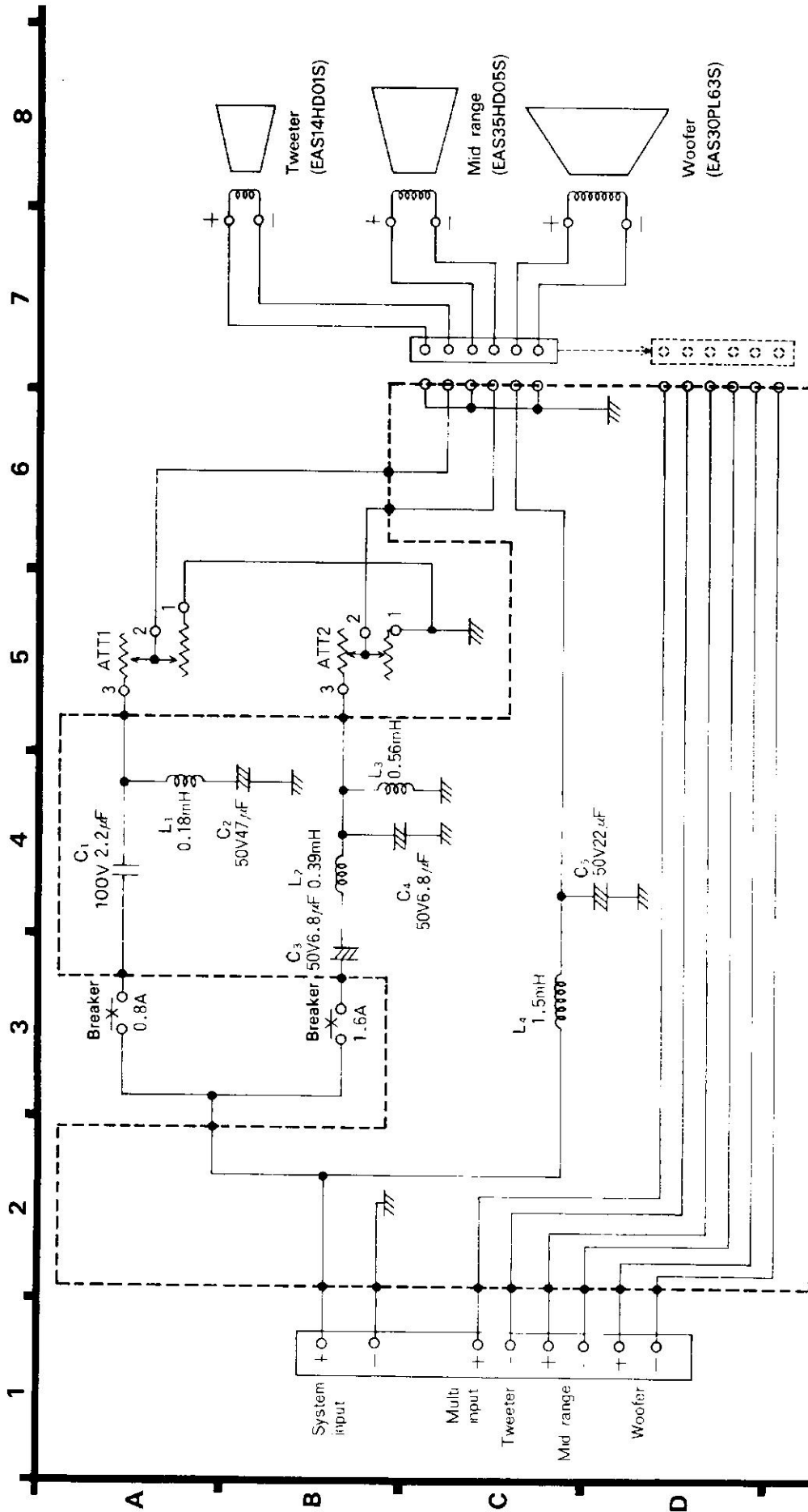

■ REPLACEMENT PARTS LIST

NOTE: 1. Part numbers are indicated on most mechanical parts  
Please use this part number for parts orders.

Ref. No.	Part No.
<b>COILS</b>	
L1	SLCA181KU
L2	SLCA391KU
L3	SLCA561KU
L4	SLCL182K1D
<b>CAPACITORS</b>	
C1	ECOE125K7
C2	FCFA50V47
C3, 4	EDFA50V688
C5	EDFA50V22

Ref. No.	Part No.
<b>BREAKERS</b>	
BR1	SSHUBAB01
BR2	SSB16AB01
<b>ATTENUATOR</b>	
ATT1, 2	EWV85AF7780

Ref. No.	Part No.
<b>SPEAKERS</b>	
SP1	EAS30PL63S
SP2	EAS35HD05S
SP3	EAS14HD01S

■ CIRCUIT BOARD

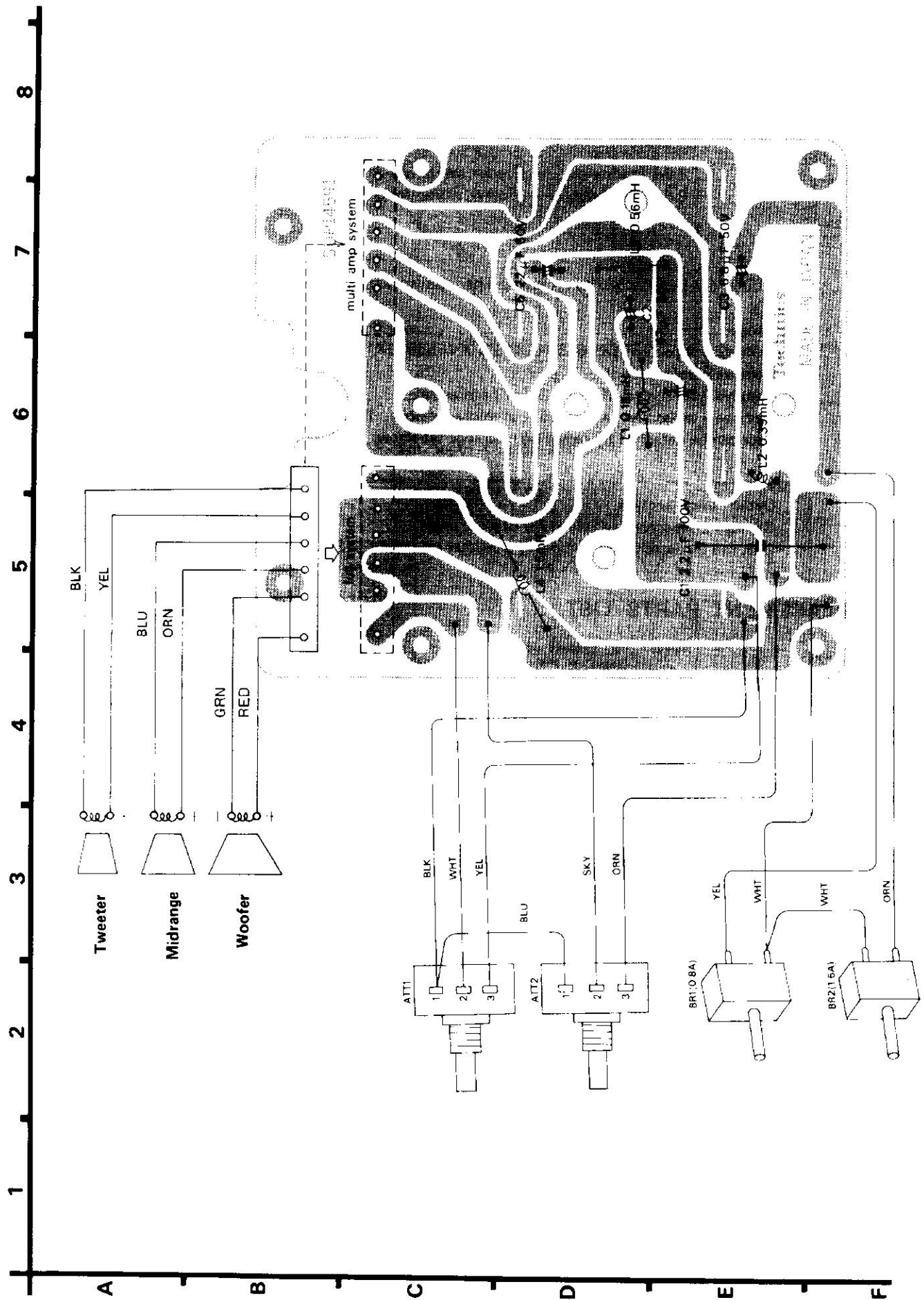

## ■ HOW TO REMOVE EACH UNIT

### \* Connections of each unit

Woofers	{ + Red - Green	Midrange	{ + Orange - Blue	Tweeter	{ + Yellow - Black
Breaker	{ 1.6A (midrange) — Orange, white (short) 0.8A (tweeter) — Yellow, white (long)				

#### • Woofers

1. Woofers can be detached by removing 4 hexagon socket head bolts (XVES6B25X1).

#### • Midrange

1. Remove 4 set-screws (XVES5B10X1S & XVES5B70X1S) to detach tower.
2. Remove woofer section.
3. Remove 2 set-screws (XSN4+12S) of horn angle.
4. Remove 4 set-screws (XSN4+45S) of midrange horn. Then take out midrange horn.
5. Unit can be detached by removing midrange set-screws (XSN4+12S).

#### • Tweeter

1. Detach tower section.
2. Remove 2 set-screws (XSN4+12S) of horn angle.
3. Unit can be detached by removing 4 tweeter set-screws (XSN4+12S).

## ■ REPLACEMENT PARTS LIST

**NOTE:** 1. Part numbers are indicated on most mechanical parts.  
Please use this part number for parts orders.

Ref. No.	Part No.	Part Name & Description	Ref. No.	Part No.	Part Name & Description
<b>CABINET PARTS</b>					
1	SKABF200G	Cabinet (Walnut)	11-3	XWG4	Washer, Plate
11	SYLB8	Foot	11-4	SNW429-1	Washer, Plate
12	XSN4+20	Screw, Foot	12	XVES5B10X1S	Screw, Tower
13	XWA4	Washer, Foot	13	SBN/83	Knob, Attenuator
1-4	XWG3	Washer, Foot	13-1	XWG8L1bFZ	Washer, Attenuator
2	SKL215	Spacer, Mid Range Horn	13-2	XWV9FZ	Washer, Attenuator
2-1	XWG4G16	Washer, Spacer	13-3	XNG9	Nut, Attenuator
2-2	XSN4+45S	Screw, Spacer	14	SME53	Bracket, Breaker
2-3	XWA4	Washer, Spacer	14-1	XTN3+12	Screw, Bracket
2-4	XWG4F13	Washer, Spacer	15	SGBE200N2	Tweeter Horn
3	SGE405-1	Bracket, Woofer	15-1	XSN4+12S	Screw, Tweeter Horn
4	XVES6B25X1	Screw, Woofer	15-2	XWA4	Washer, Tweeter Horn
4-1	XWAR6BFZ	Washer, Woofer	15-3	XWG4	Washer, Tweeter Horn
4-2	SNW653	Washer, Woofer	16	SGLBL100N1	Lid, Tweeter Horn
5	SYB555-1	Grille	16-1	XSN3+81ZS	Screw, Lid
5-1	SGB533	Badge	16-2	XWA3	Washer, Lid
6	SME55-1	Bracket, Tower, Left	16-3	XWG3	Washer, Lid
7	SME57	Bracket, Tower, Left	17	XVES4B16X1S	Screw, Lid
8	SME55	Bracket, Tower, Right	17-1	XWA4BFZ	Washer, Lid
8-1	XSN4+12S	Screw, Tower	18	SGBF200N1	Mid Range Horn
8-2	XWG4	Washer, Tower	18-1	XSN4+12S	Screw, Mid Range Horn
8-3	XIN3-8	Screw, Bracket	18-2	XWA4	Washer, Mid Range Horn
8-4	XWG3	Washer, Bracket	18-3	XWG4	Washer, Mid Range Horn
8-5	XSN4+30S	Screw, Cabinet	19	SGBE100N3	Lid, Mid Range Horn
8-6	XWG4	Washer, Cabinet	19-1	XVES4B16X1S	Screw, Lid
9	SWT403	Terminal Assy	19-2	XWA4BFZ	Washer, Lid
9-1	SNE273-2	Knob, Terminal	19-3	SNW429-1	Washer, Lid
9-2	XTN3+12	Screw, Terminal	19-4	XSN4+16S	Screw, Lid
9-3	XWG3	Washer, Terminal	19-5	XWA4	Washer, Lid
10	SGBE100N4	Tower with Panel	19-6	XWG4	Washer, Lid
10-1	XVES5B70X1S	Screw, Tower & Cabinet	20	SUW1367	Bracket, Mid Range Lid
10-2	XWA5BFZ	Washer, Tower	20-1	XSN3+8S	Screw, Bracket
10-3	SHW49N100	Washer, Tower	20-2	XWA3	Washer, Bracket
11	SGU101-1	Plate	20-3	XWG3	Washer, Bracket
11-1	XSN4+10FZS	Screw, Plate			
11-2	XWA4	Washer, Plate			

# EXPLODED VIEW

## CABINET

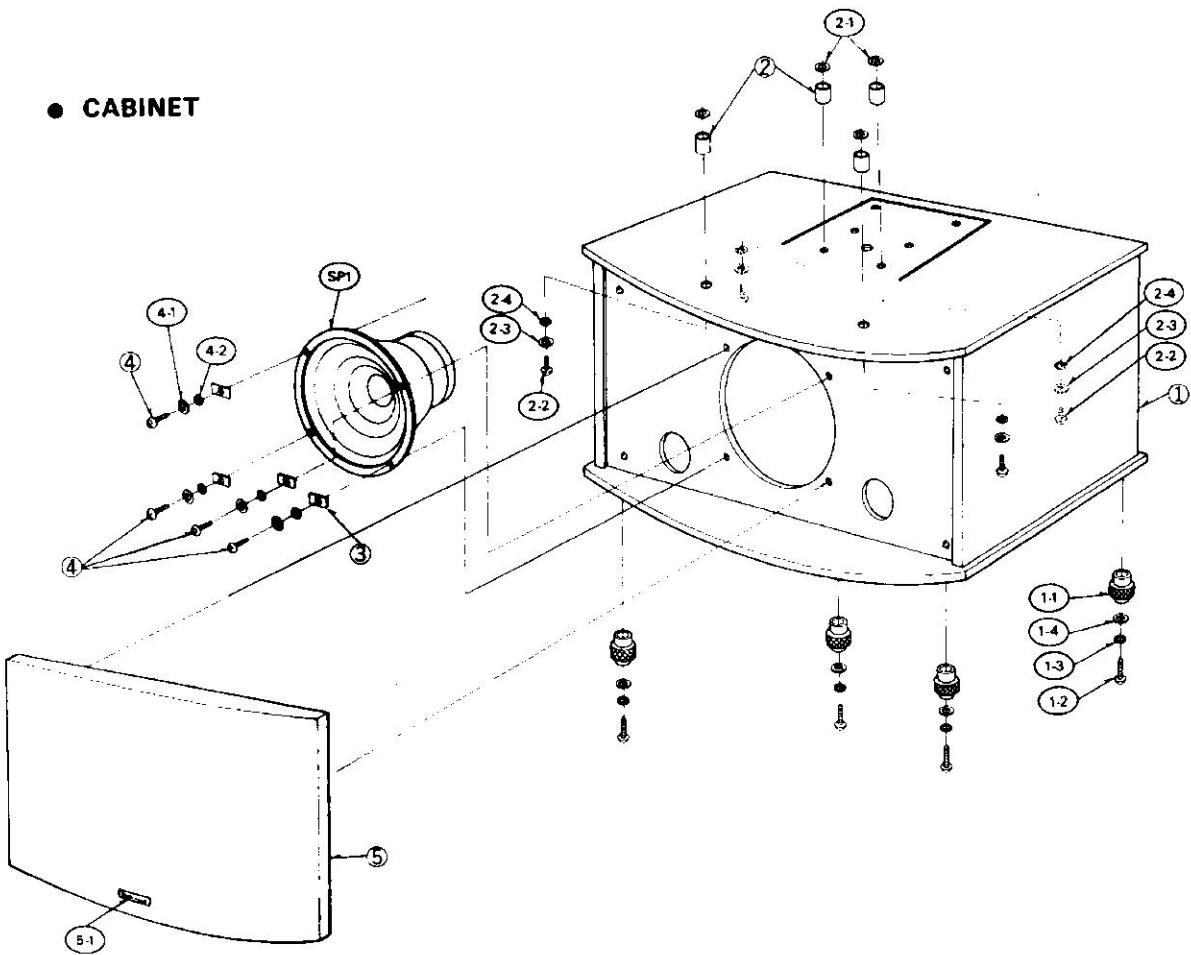

## TWEETER

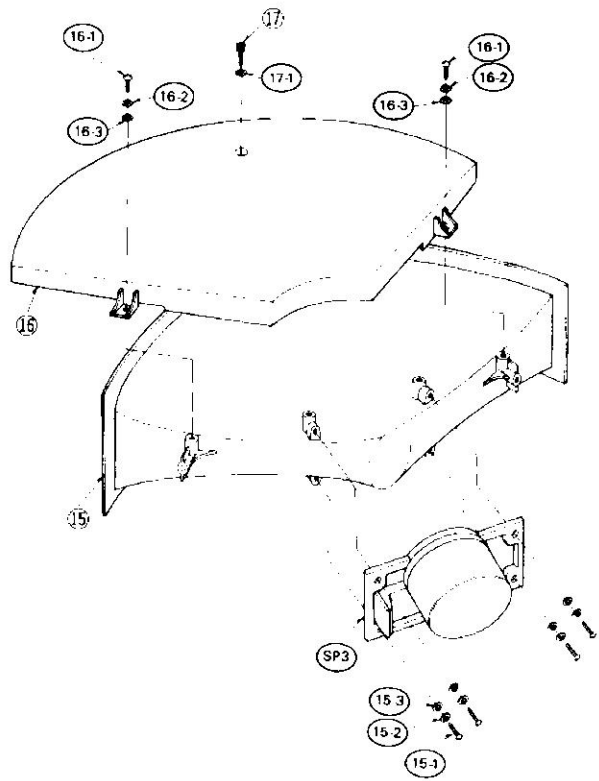

## TOWER

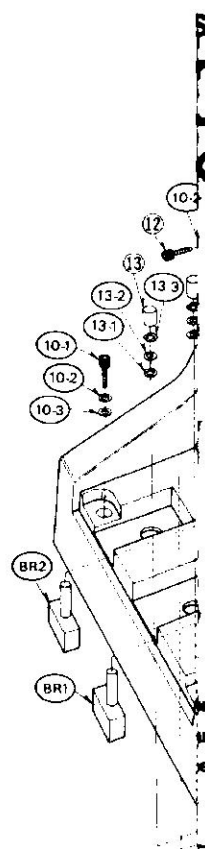

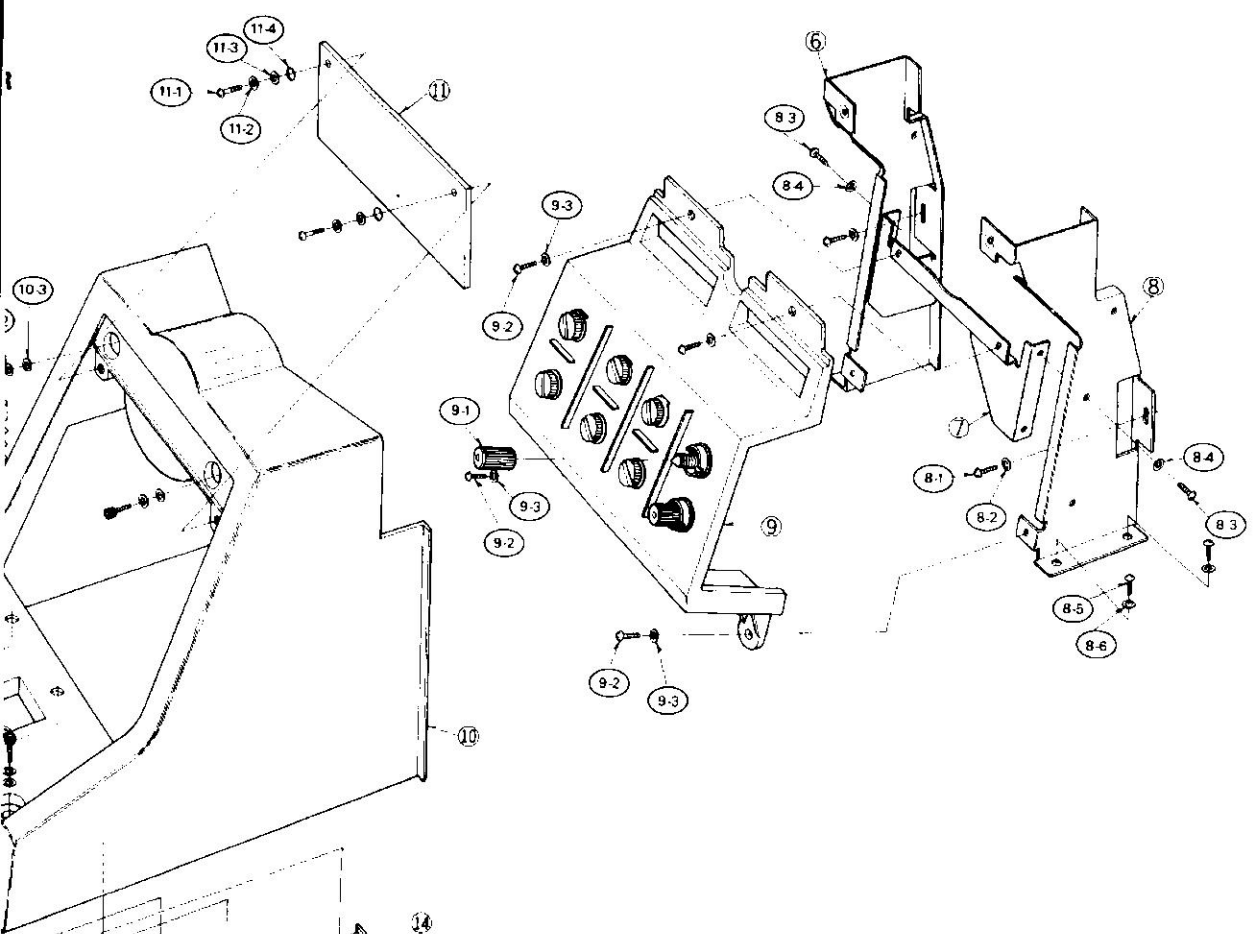

● **MIDRANGE**

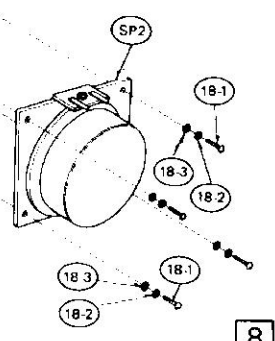
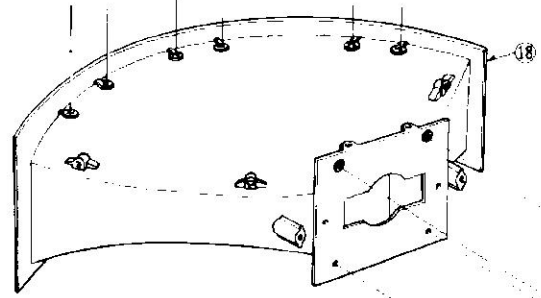
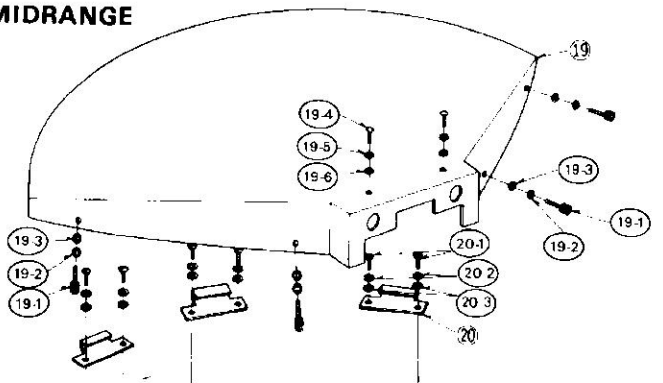
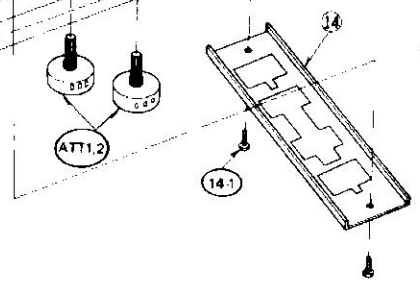



# RESPONSE CHARTS

1 Amplitude/Frequency Response and Phase/Frequency Response (MIC-SP. 2m, Input Voltage 2.45V)

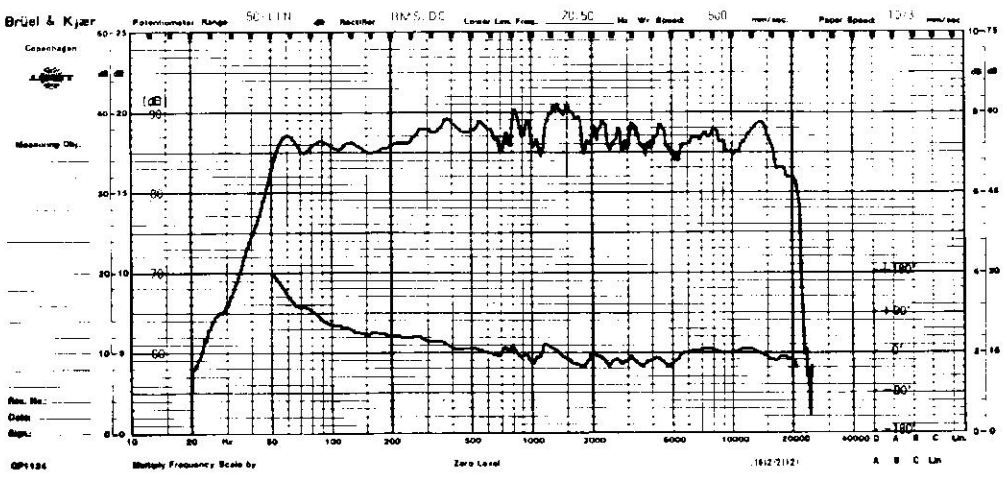

2. Harmonic Distortion Characteristics (MIC-SP. 2m, Input Voltage 2.45V)

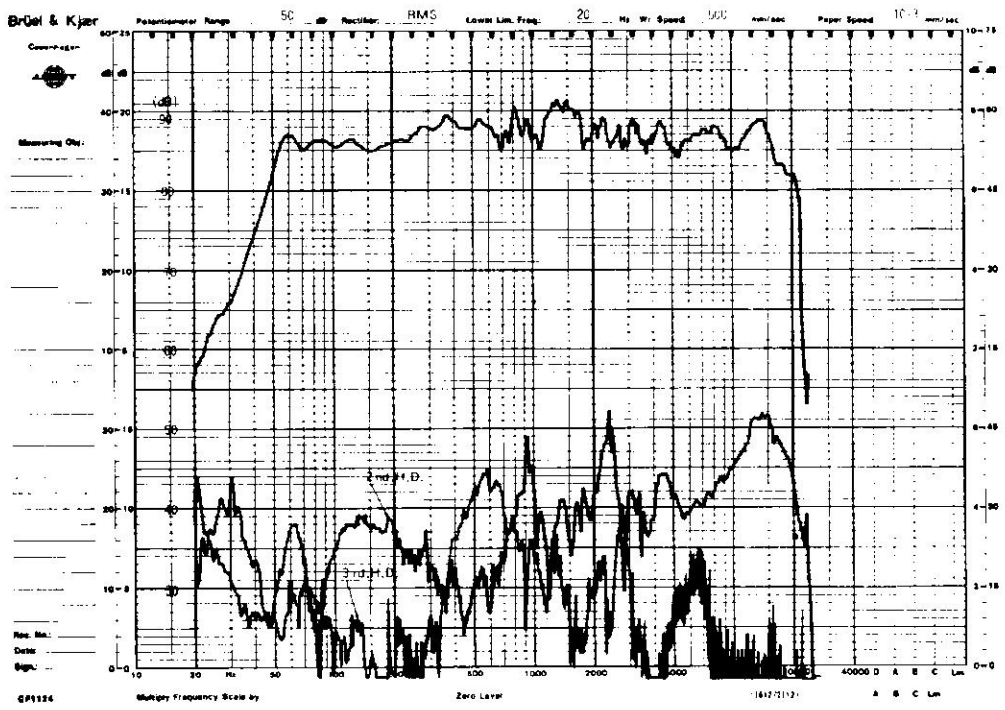

3. Directional Characteristics and Impedance Response (MIC-SP. 2m, Input Voltage 2.45V)

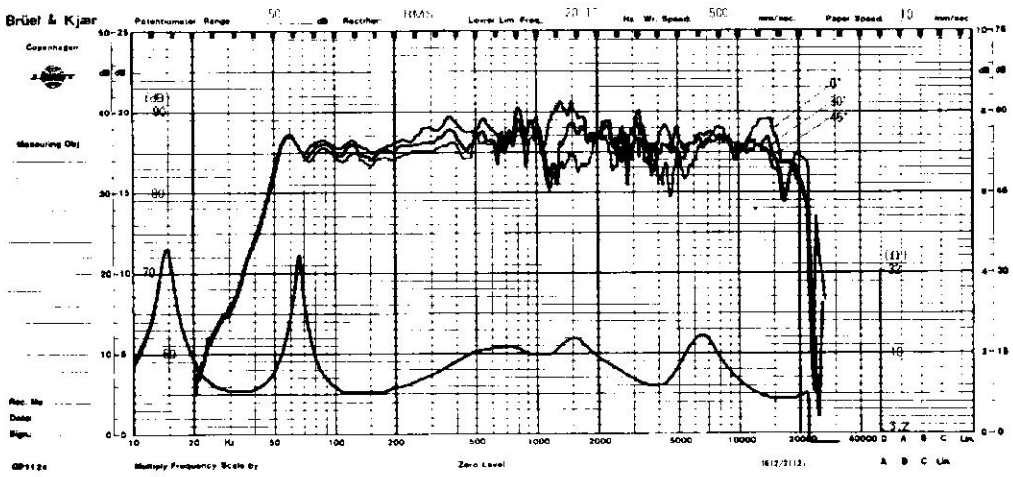

## ■ PACKINGS

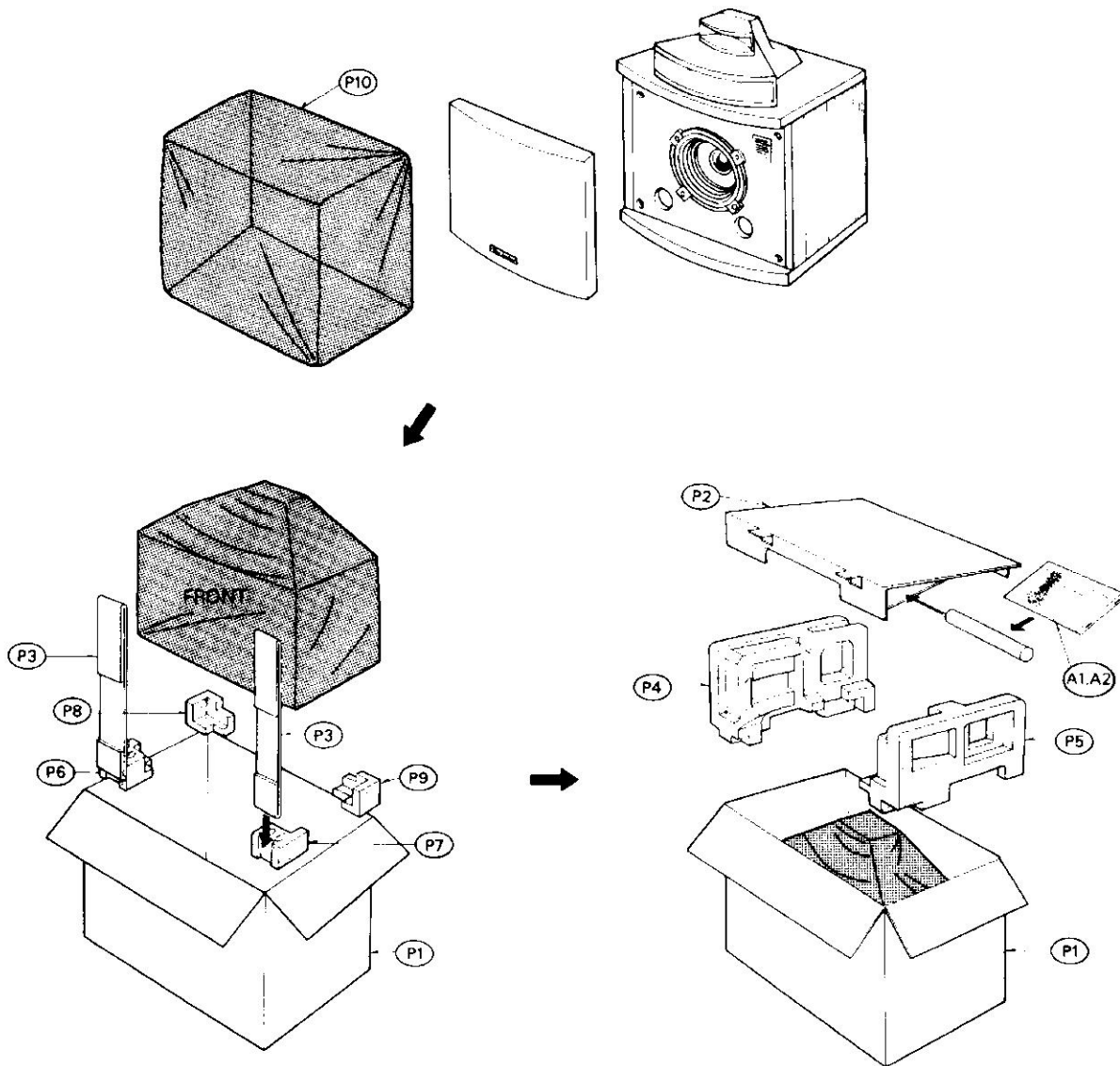

## ■ REPLACEMENT PARTS LIST

**NOTES:** 1. Part numbers are indicated on most mechanical parts  
Please use this part number for parts orders.

2. SB-E200(XG) → (XG)      SB-E200(XGE) → (XGE)  
SB-F200(XGF) → (XGF)

Ref. No.	Part No.	Part Name & Description
<b>ACCESSORY PARTS</b>		
A1	SQF10049	Instruction Book
A2	SWX291	Speaker Cord
<b>PACKING PARTS</b>		
P1 (XG,XGE)	SPG1695-1	Carton
P1 (XGF)	SPG1695-2	Carton
P2	SPS1835	Pad, Top
P3	SPS1837	Pad, Front
P4	SPS1709	Pad, Corner, Left
P5	SPS1709-1	Pad, Corner, Right
P6	SPS1711	Pad, Corner, Front
P7	SPS1711-1	Pad, Corner, Front
P8	SPS1713	Pad, Corner, Rear
P9	SPS1713-1	Pad, Corner, Rear
P10	SPP601	Polyethylene Bag