

Service Manual

Speaker System

SB-EH560

SB-EH760

System No. SC-EH560 & SC-EH760

Colour

(S).....Silver Type

Area

(E).....Europe.

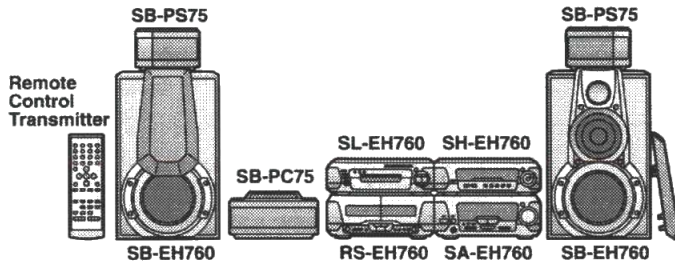

Specification

■SB-EH560

Type:	3 way, 3 speakers
Speakers	
Super woofer;	14cm cone type
Woofer;	12cm cone type
Tweeter;	6cm cone type
Impedance:	High 6Ω Mid 6Ω Low 6Ω
Input power (Music):	High 40W Mid 40W Low 70W
Output sound pressure level:	84dB/W (1.0m)
Crossover frequency:	150Hz, 4kHz
Frequency range:	46Hz - 22kHz (-16dB) 50Hz - 20kHz (-10dB)
Dimensions (W×H×D):	254×422×260 mm
Mass:	6.0 kg

■SB-EH760

Type:	3 way, 3 speakers
Speakers:	
Super woofer;	17cm cone type
Woofer;	12cm cone type
Tweeter;	6cm ring shaped dome type
Impedance:	High 6Ω Mid 6Ω Low 8Ω
Input power (Music):	High 60W Mid 60W Low 120W
Output sound pressure level:	87dB/W (1.0m)
Crossover frequency:	120Hz, 4kHz
Frequency range:	42Hz - 50kHz (-16dB) 46Hz - 36kHz (-10dB)
Dimensions (W×H×D):	254×422×260mm
Mass:	6.4kg

Notes:

Specifications are subject to change without notice.

Weight and dimensions are approximate.

⚠ WARNING

This service information is designed for experienced repair technicians only and is not designed for use by the general public. It does not contain warnings or cautions to advise non-technical individuals of potential dangers in attempting to service a product. Products powered by electricity should be serviced or repaired only by experienced professional technicians. Any attempt to service or repair the product or products dealt with in this service information by anyone else could result in serious injury or death.

Technics®

© 2000 Matsushita Electric Industrial Co., Ltd. All rights reserved. Unauthorized copying and distribution is a violation of law.

CONTENTS

	Page		Page
1 Schematic Diagram	2	4 Cabinet Parts Location	7
2 DISASSEMBLY INSTRUCTIONS	3	5 Packaging	8
3 Replacement Parts List	6		

1 Schematic Diagram

●SB-EH560

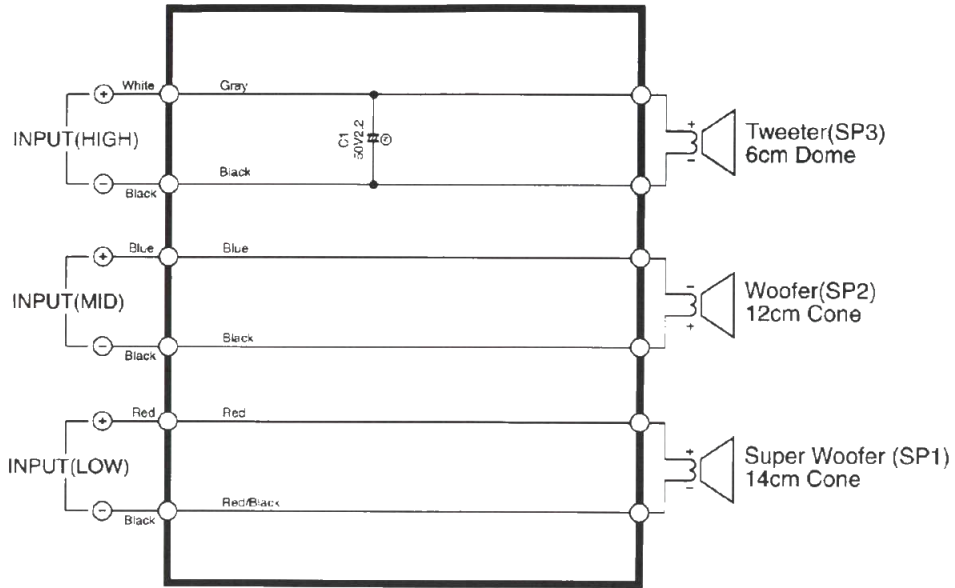

●SB-EH760

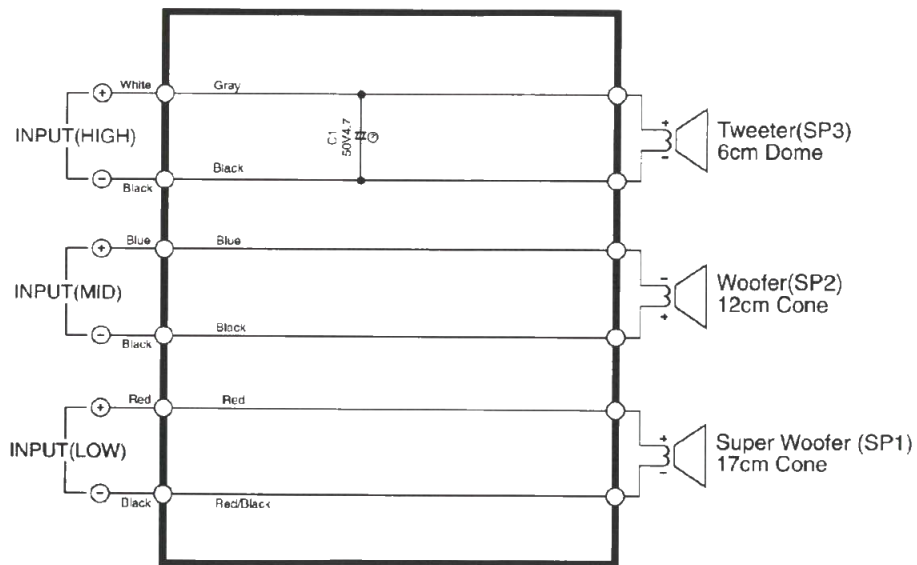

2 DISASSEMBLY INSTRUCTIONS

2.1. Removal of the speaker (Super woofer)

(Step 2)
Remove the speaker net ass'y.

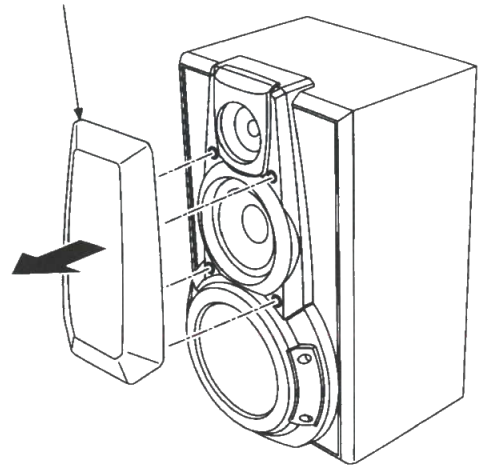

(Step 2)
Remove the 4 net catch gums.

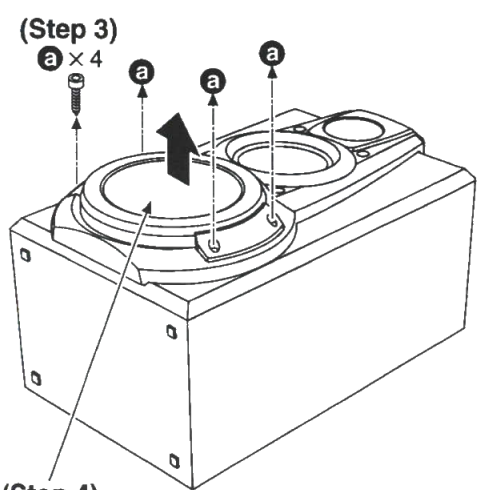
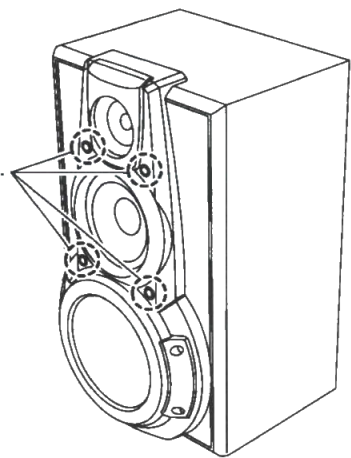

(Step 4)
Remove the woofer ring ass'y.

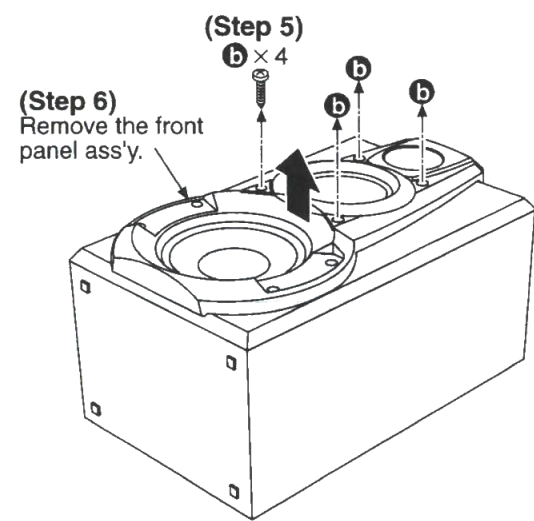

(Step 6)
Remove the front panel ass'y.

■ Removal of the net catch gum

The diagram illustrates the removal of a net catch gum in three steps: (1) Inserting a plus screwdriver into the gum and pushing it in slightly. (2) Lifting the gum with the screwdriver. (3) Grasping the gum with a finger and pulling it out.

1. Insert the plus screwdriver or similar tool into net catch gum, push in slightly in the direction of arrow (1) to avoid scratching, the cabinet ass'y and lift in the direction of arrow (2).

2. After lifting the net catch gum, grasp it with your finger and remove in the direction of arrow (3).

(Step 8)
Lift up the speaker (Super woofer).

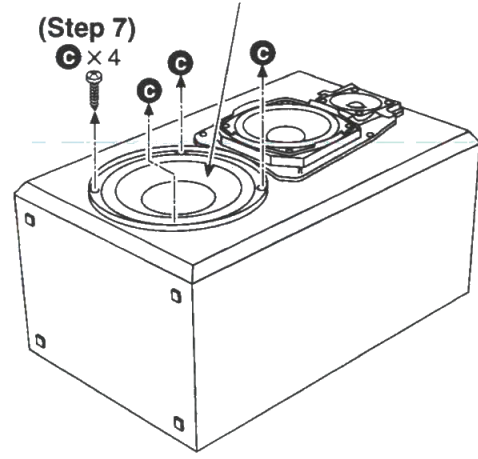

(Step 7)

(Step 9)

Remove the speaker lead wires, and then remove the speaker (Super woofer).

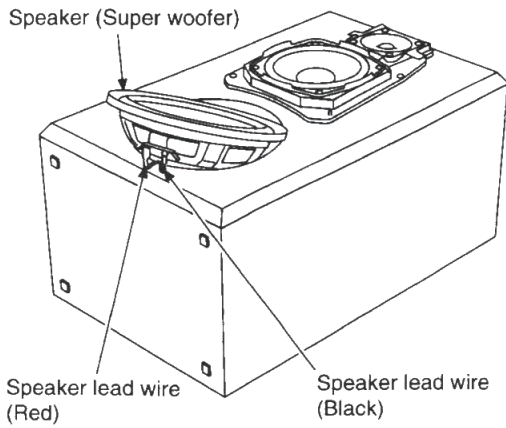

2.2. Removal of the speaker (Woofer)

• Follow the (Step 1) - (Step 6) of item 2.1.

(Step 1)

a × 4

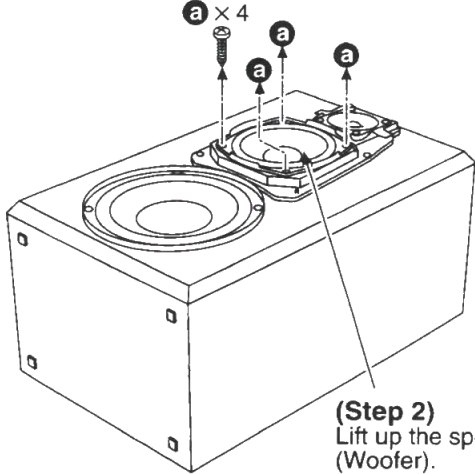

(Step 2)

Lift up the speaker (Woofer).

(Step 3)

Remove the speaker lead wires, and then remove the speaker (Woofer).

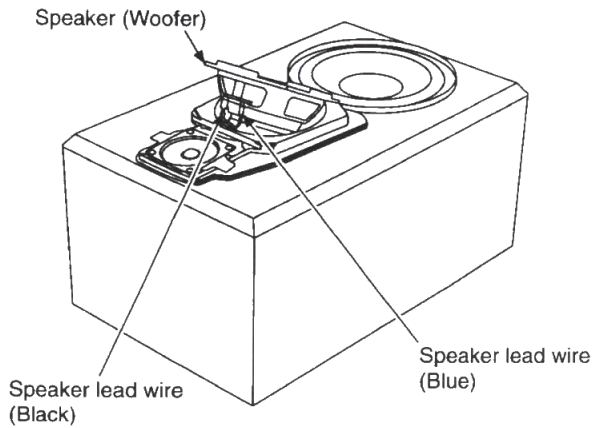

2.3. Removal of the speaker (Tweeter)

• Follow the (Step 1) - (Step 6) of item 2.1.

(Step 1)

a × 4

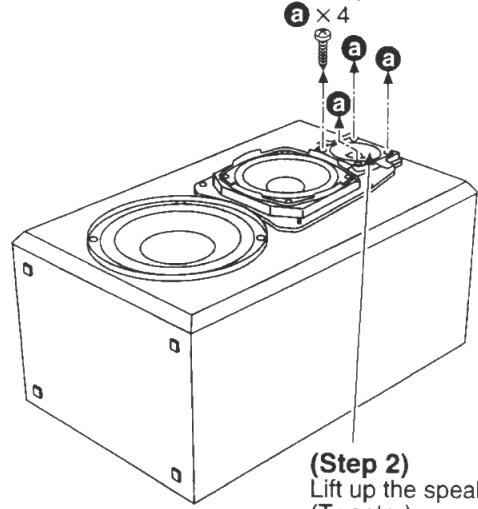

(Step 2)

Lift up the speaker (Tweeter).

(Step 3)

Remove the speaker lead wires, and then remove the speaker (Tweeter).

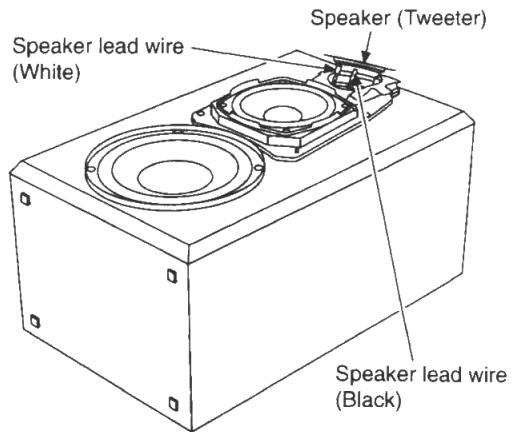

2.4. Removal of the terminal board

- Follow the **(Step 1)** - **(Step 9)** of item 2.1.
- Follow the **(Step 1)** - **(Step 3)** of item 2.2.
- Follow the **(Step 1)** - **(Step 3)** of item 2.3.

(Step 1)

Cut the melted bosses (2 points) off with similar tool like a knife.

(Step 2)

After replacing the parts, melt the 2 spare bosses with solder iron.

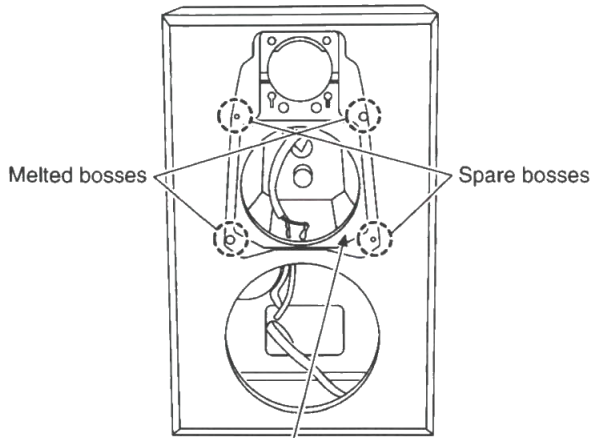

(Step 3)

Remove the cavity cover.

(Step 4)

Remove the cord bushing.

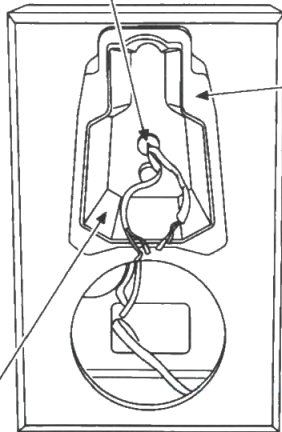

(Step 6)

Remove the back cavity.

(Step 5)

Remove the packing.

(Step 8)
Remove the terminal board.

(Step 7)

a × 4

a

a

a

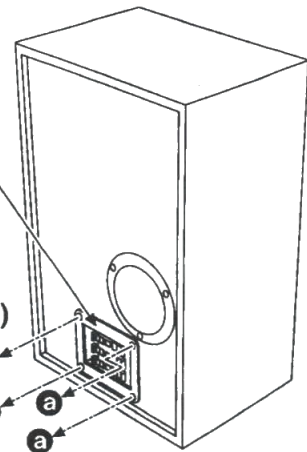

3 Replacement Parts List

3.1. SB-EH560

Note: All parts are supplied by MAES.

Ref.No.	Part No.	Part Name & Description	Pcs	Remarks
1	RGP0781A-S	FRONT PANEL	1	(MAES)
2	RGP0788-S	ORNAMENT, TWEETER	1	(MAES)
3	XTB31BZ+8	SCREW	4	(MAES)
4	RYQ0286-S	WOOFER RING ASS'Y	1	(MAES)
5	RGN1858-K	NAME PLATE	1	(MAES)
6	SHGS8G9071	CORD BUSHING	1	(MAES)
7	RMR1283-K	CAVITY COVER	1	(MAES)
8	RMR1282-K	BACK CAVITY	1	(MAES)
9	RMQ0944	PACKING, BACK CAVITY	1	(MAES)
10	RKTP0029-K	BASS REFLEX PORT	1	(MAES)
11	SHG8G9044	NET CATCH GUM	4	(MAES)
12	REJ0147	TERMINAL BOARD	1	(MAES)
13	XTN42+20FG	SCREW	4	(MAES)
14	SNES4+40S	SCREW	4	(MAES)
15	XTNP42+25	SCREW	4	(MAES)
16	XTN42+20	SCREW	7	(MAES)
17	XTN42+16	SCREW	6	(MAES)
18	XTN42+25	SCREW	2	(MAES)
19	RYK1003-M	CABINET ASS'Y	1	(MAES)
19-1	RKA0072-K	FOOT	4	(MAES)
20	RYB0235A	SPEAKER NET ASS'Y	1	(MAES)
21	RMQ0621	PACKING, TWEETER	1	(MAES)
22	RMQ0622	PACKING, WOOFER	1	(MAES)
23	RMQP0647	PACKING, SUPER WOOFER	1	(MAES)
C1	ECEA1HAY2R2	50V 2.2UF	1	(MAES)
P1	RPGP4838	PACKING CASE	1	(MAES)
P2	RPN1198C	CUSHION	1	(MAES)
P3	SPHP35G-35	PROTECTION SHEET	1	(MAES)
SP1	EAS14PL317L3	SUPER WOOFER	1	(MAES)
SP2	EAST12P26A6	WOOFER	1	(MAES)
SP3	EASJ6PH03B3	TWEETER	1	(MAES)

Ref.No.	Part No.	Part Name & Description	Pcs	Remarks
P1	RPGP4673	PACKING CASE	1	(MAES)
P2	RPN1198C	CUSHION	1	(MAES)
P3	SPHP35G-35	PROTECTION SHEET	1	(MAES)
SP1	EAST17PL07B6	SUPER WOOFER	1	(MAES)
SP2	EAST12P27A6	WOOFER	1	(MAES)
SP3	EAST6PH06B6	TWEETER	1	(MAES)

3.2. SB-EH760

Note: All parts are supplied by MAES.

Ref.No.	Part No.	Part Name & Description	Pcs	Remarks
1	RGP0781A-S	FRONT PANEL	1	(MAES)
2	RYQ0293-A	ORNAMENT, TWEETER	1	(MAES)
3	XTB31BZ+8	SCREW	4	(MAES)
4	RYQ0286-H	WOOFER RING ASS'Y	1	(MAES)
5	RGN1779A-K	NAME PLATE	1	(MAES)
6	SHGS8G9071	CORD BUSHING	1	(MAES)
7	RMR1283-K	CAVITY COVER	1	(MAES)
8	RMR1282-K	BACK CAVITY	1	(MAES)
9	RMQ0944	PACKING, BACK CAVITY	1	(MAES)
10	RKTP0029-K	BASS REFLEX PORT	1	(MAES)
11	SHG8G9044	NET CATCH GUM	4	(MAES)
12	REJ0146	TERMINAL BOARD	1	(MAES)
13	XTN42+20FG	SCREW	4	(MAES)
14	SNES4+40S	SCREW	4	(MAES)
15	XTNP42+25	SCREW	4	(MAES)
16	XTN42+20	SCREW	7	(MAES)
17	XTN42+16	SCREW	6	(MAES)
18	XTN42+25	SCREW	2	(MAES)
19	RYK0990-M	CABINET ASS'Y	1	(MAES)
19-1	RKA0072-K	FOOT	4	(MAES)
20	RYB0235	SPEAKER NET ASS'Y	1	(MAES)
21	RMQ0621	PACKING, TWEETER	1	(MAES)
22	RMQ0622	PACKING, WOOFER	1	(MAES)
23	RMQP0647	PACKING, SUPER WOOFER	1	(MAES)
C1	ECEA1HAY4R7	50V 4.7UF	1	(MAES)

4 Cabinet Parts Location

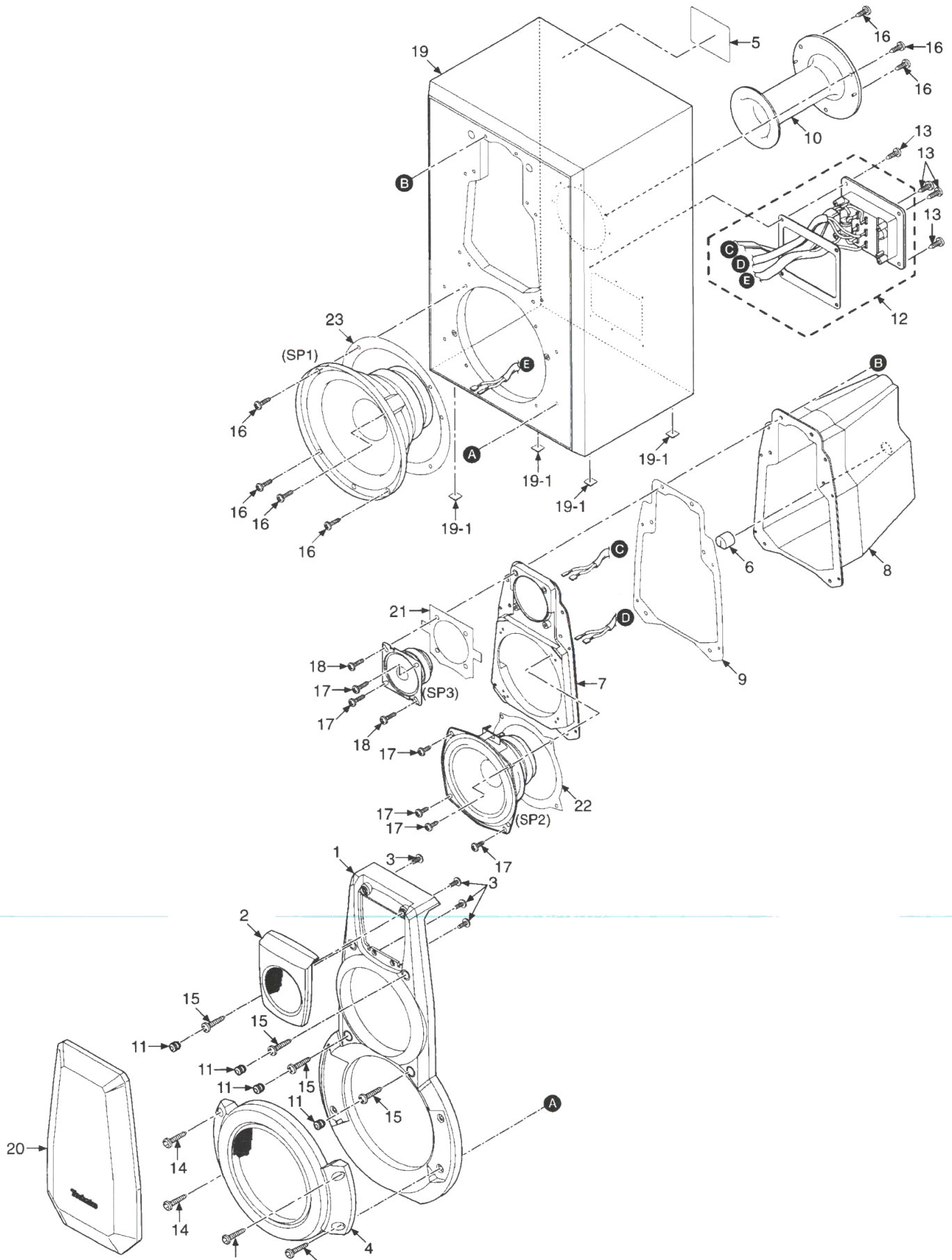

5 Packaging

