

Service Manual

Speaker System SB-M1000

Hi-Fi Speaker System

Colour

(M) Wood



■ SPECIFICATIONS

Type	4-way 7-speaker system
Speakers	Woofer: Dual Dynamic Drive System 18 cm pasive radiator x 4 14 cm cone type driver unit x 4 Midrange: Mid Low 14 cm cone type Mid High 8 cm cone type Tweeter: 2.5 cm dome type
Impedance	6 Ω
Input Power	200 W (Music) 100 W (DIN)
Output Sound Pressure Level	86 dB/W (1.0 m)
Crossover Frequency	90 Hz; 900 Hz; 3.5 kHz
Frequency Range	25 Hz \approx 80 kHz (-16 dB) 30 Hz \approx 75 kHz (-10 dB)
Dimensions (W x H x D)	284 x 1190 x 447 mm
Weight	42 kg

Note:

Design and specifications are subject to change without notice.

■ ESPECIFICACIONES

Tipo	Sistema de 4 vías con 7 altavoces
Altavoces	Graves: Dual Dynamic Drive System radiador pasivo de 18 cm x 4 activo tipo cónico de 14 cm x 4 Medios: Medios graves tipo cónico de 14 cm Medios agudos tipo cónico de 8 cm Agudos: tipo cúpula de 2,5 cm
Impedancia	6 Ω
Capacidad de potencia	200 W (Musicales) 100 W (DIN)
Nivel de presión acústica de salida	86 dB/W (1,0 m)
Frecuencia de cruce	90 Hz; 900 Hz; 3,5 kHz
Respuesta de frecuencias	25 Hz \approx 80 kHz (-16 dB) 30 Hz \approx 75 kHz (-10 dB)
Dimensiones (W x H x D)	284 x 1190 x 447 mm
Peso	42 kg

Nota:

Estas especificaciones están sujetas a cualquier cambio sin previo aviso.

■ SPECIFICATIONS

Type	4-voies 7-haut-parleurs
Haut-parleurs	Graves: Dual Dynamic Drive System Graves: 18 cm difuseur pasive x 4 14 cm type a cone excitateur active x 4 Moyennes: Mid Low 14 cm type a cone Mid High 8 cm type a cone Aigus: 2,5 cm type dome
Impédance	6 Ω
Entrée maximale	200 W (Musique) 100 W (DIN)
Niveau de pression sonore de sortie	86 dB/W (1,0 m)
Fréquence de commutation	90 Hz; 900 Hz; 3,5 kHz
Gamme de fréquences	25 Hz \approx 80 kHz (-16 dB) 30 Hz \approx 75 kHz (-10 dB)
Dimensions (W x H x D)	284 x 1190 x 447 mm
Poids	42 kg

Note:

Subject à changement sans preavis.

⚠ WARNING

This service information is designed for experienced repair technicians only and is not designed for use by the general public. It does not contain warnings or cautions to advise non technical individuals of potential dangers in attempting to service product. Products powered by electricity should be serviced or repaired only by experienced professional technicians. Any attempt to service or repair the product or products dealt with in this service information by anyone else could result in serious injury or death.

DISASSEMBLY INSTRUCTIONS

Ref. No. 1	Removal of the Speaker Net	Ref. No. 2	Removal of the Speaker Tweeter
------------	----------------------------	------------	--------------------------------

Procededure 1

Procededure 1 → 2

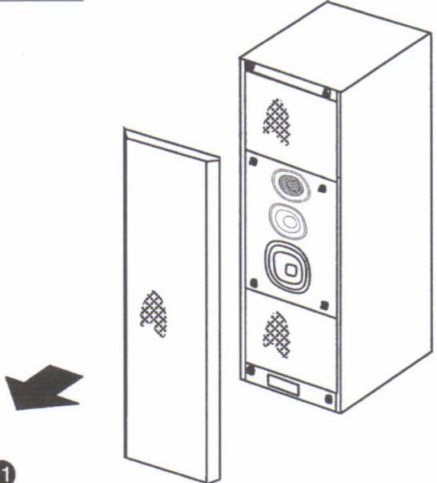

Step 1

- Remove the Speaker Net in the direction of arrow.

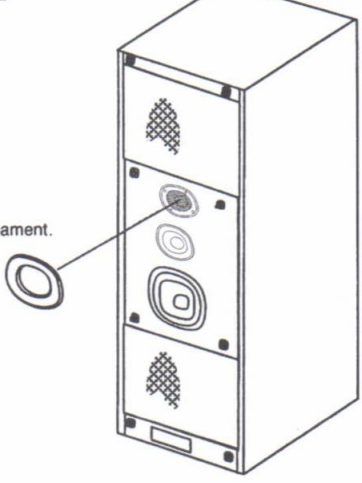

Step 1

- Remove the Speaker Ornament.

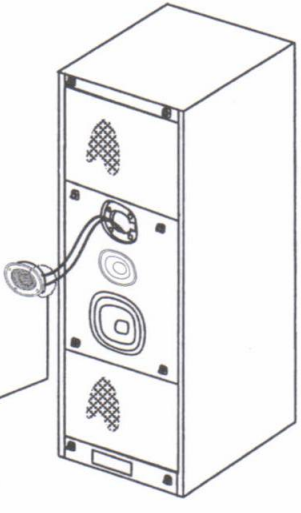

Step 3

- Remove the Speaker Tweeter in the direction of front part.

Step 4

- Remove the 2 Speaker Terminals.

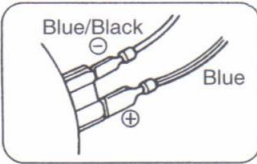
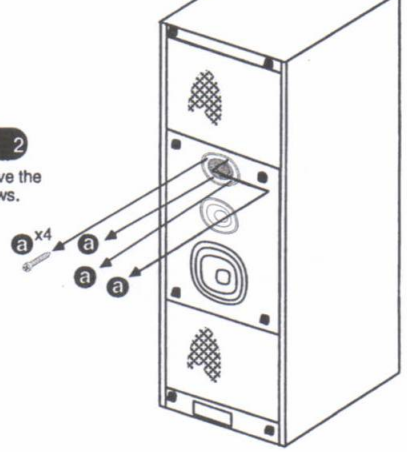
Step 2

- Remove the 4 screws.



Screw Ø 4.2 x 25 mm

Ref. No. 3	Removal of the Speaker Mid High
------------	---------------------------------

Procededure 1 → 3

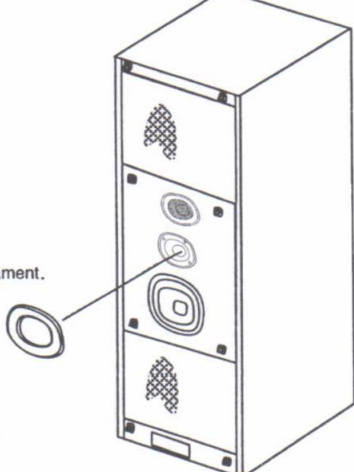

Step 1

- Remove the Speaker Ornament.



Screw Ø 4.2 x 25 mm

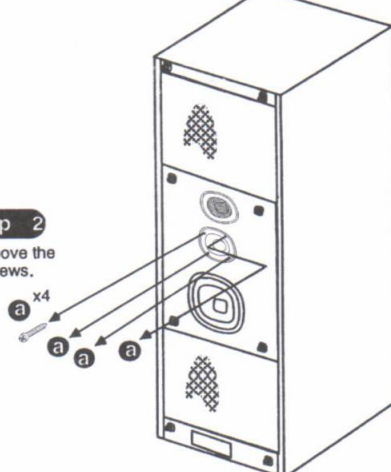

Step 2

- Remove the 4 screws.

Step 4

- Remove the 2 Speaker Terminals.

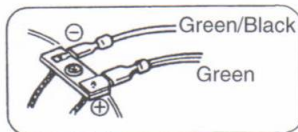

Step 3

- Remove the Speaker Mid High in the direction of front part.

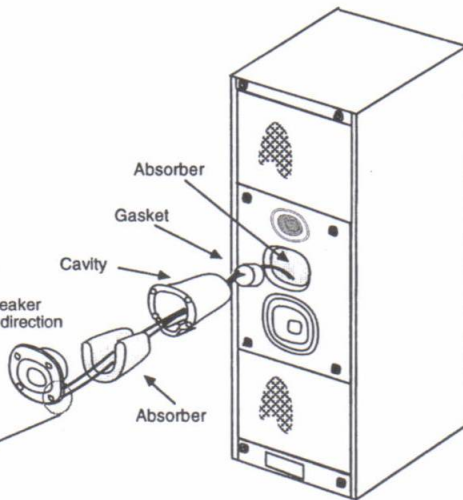

Ref. No. 4

Removal of the Speaker Mid Low

Procededure 1 → 4

Step 1

- Remove the Speaker Ornament.

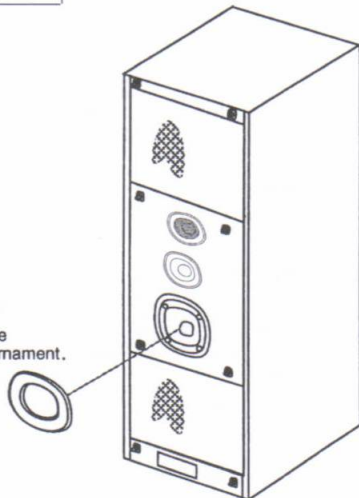

Step 2

- Remove the 4 screws.

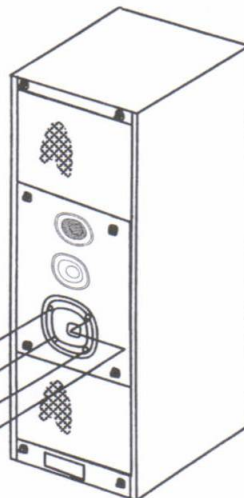
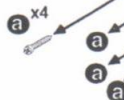

Step 4

- Remove the 2 Speaker Terminals.

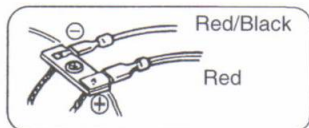

Step 3

- Remove the ring Mid Low.

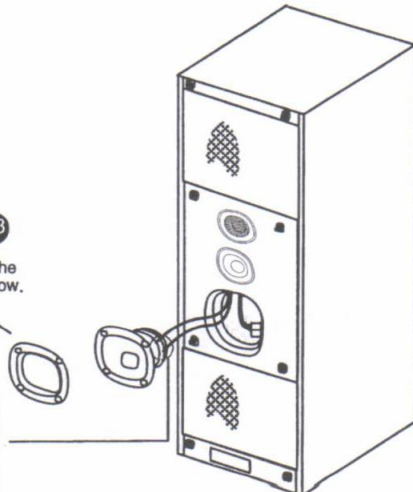

Screw Ø 4.2 x 25 mm

Ref. No. 5

Removal of the Front Panel

Procededure 1 → 5

Step 1

- Remove the 4 Catch pin.

■ Removal of the Catch Pin.



Put the tape in Catch Pin.

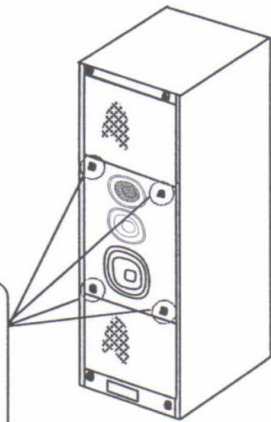

Step 2

- Remove the 4 Net Holder.

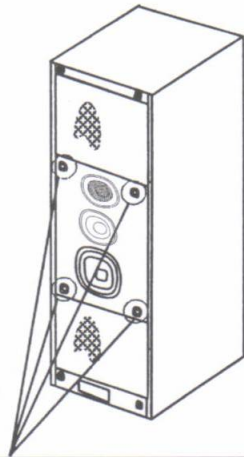

■ Removal of the Net Holder

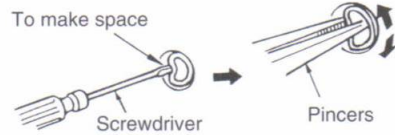

1. To use a screwdriver ⊖ and make space between the front panel and the Net Holder.
 2. To insert the pincers type point and take the Net Holder to rotate.
- ※ Pay attention not to break the Net Holder. Please, they stock the Net Holder. (SHG8G9044).

■ Inserting the Net Holder and Catch Pin

1. Insert the Net Holder using the 5 mm type hexagonal wrench or similar tool like rod.
2. After inserting the Catch Pin, press the Catch Pin covering with cloth using the hammer or screwdriver grip.

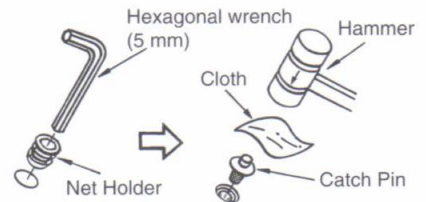

Step 3

- Remove the 4 screws.

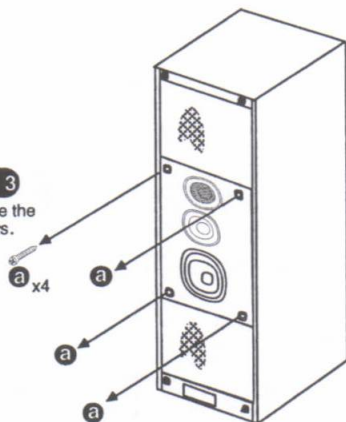

Step 4

- Remove the Front Panel in the direction of front part.

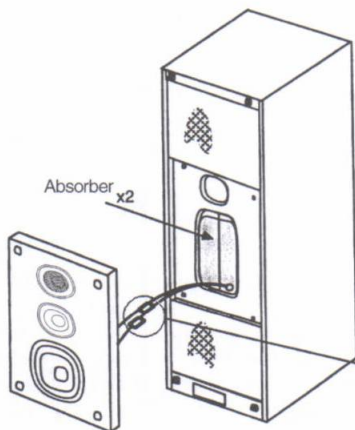

Step 5

- Remove the 2 Terminals.

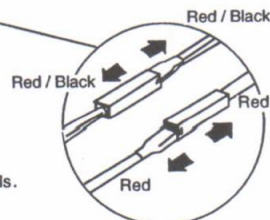

Screw Ø 4.2 x 32 mm

Ref. No. 6 Removal of the Network Ass'y

Procededure 1 → 5 → 6

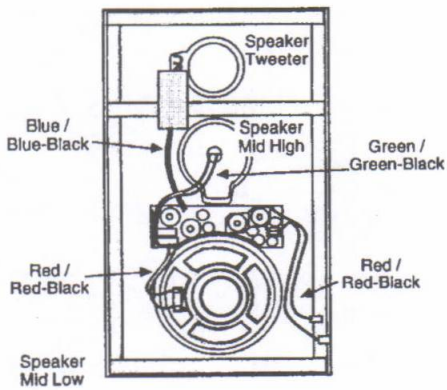

Step 1

• Remove the 6 Screws.

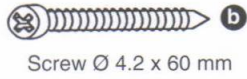
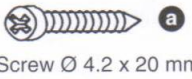
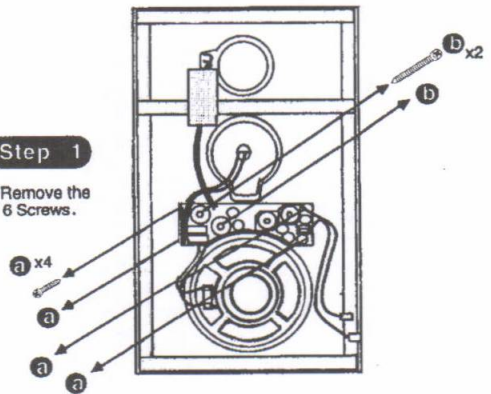

Ref. No. 7 Removal of the Speaker Woofer

Procededure 1 → 5 → 7

Down Frontal

Step 1

• Remove the Net Frame in the direction of arrow.

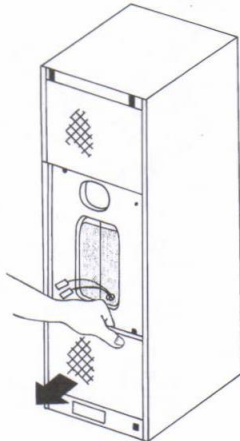

Step 5

• When remove the Speaker tilting it as indicated in this picture.

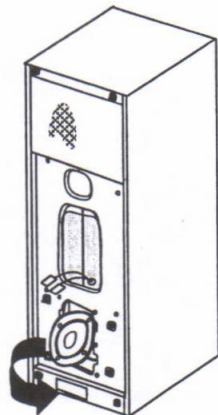

ATTENTION

• When assembly the Passive Radiator put UP mark to upward.

Step 2

• Remove the 6 Screws

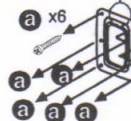

Step 3

• Remove the Passive Radiator and Gasket.

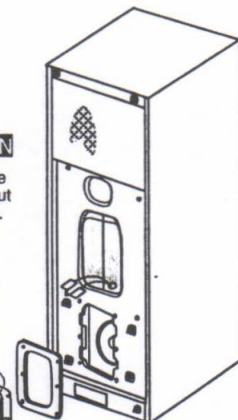

Step 4

• Remove the 4 Screws.

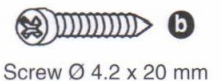
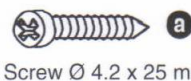

Ref. No. 8

Removal of the Speaker Woofer

Procededure 1 → 5 → 8

Up Frontal

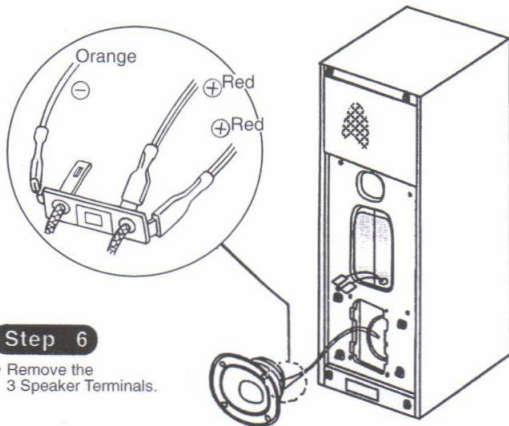

Step 6

- Remove the 3 Speaker Terminals.

Step 1

- Remove the Net Frame in the direction of arrow.

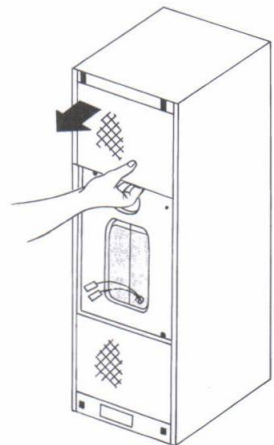

Step 4

- Remove the 4 Screws.

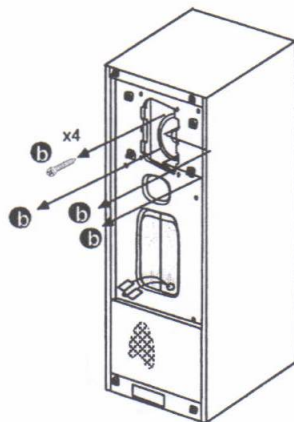

ATTENTION

- When assembly the Passive Radiator put UP mark to upward.

Step 2

- Remove the 6 Screws.

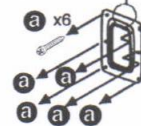

Step 3

- Remove the Passive Radiator and Gasket.

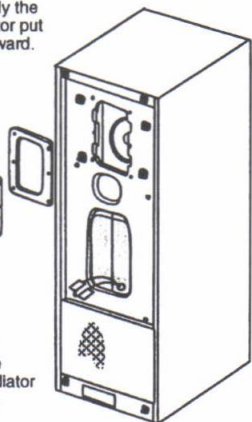

Step 5

- When remove the Speaker tilting it as indicated in this picture.

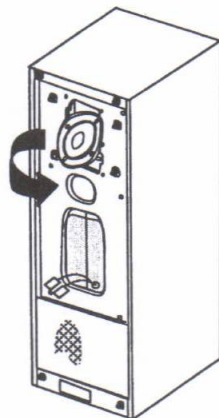

Step 6

- Remove the 2 Speaker Terminals.

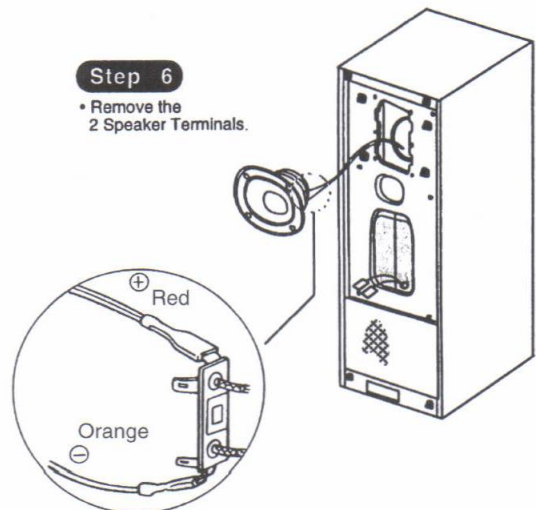

a

Screw Ø 4.2 x 25 mm



b

Screw Ø 4.2 x 20 mm

Ref. No. 9	Removal of the Speaker Woofer
Procededure 9	Down Rear

ATTENTION

• When assembly the Passive Radiator put UP mark to upward.

Step 1

• Remove the 6 Screws.

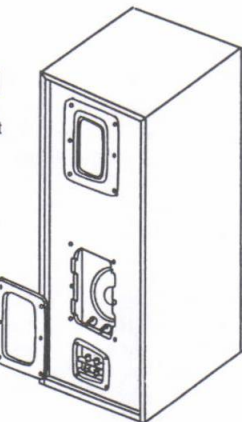
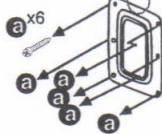

Step 2

• Remove the Passive Radiator and Gasket.

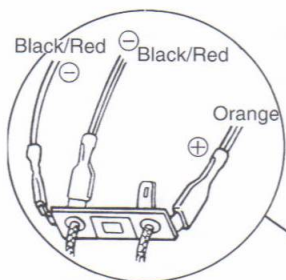

Step 5

• Remove the 3 Speaker Terminals.



Step 3

• Remove the 4 Screws.

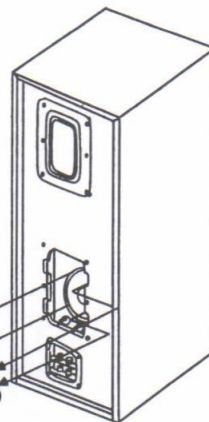
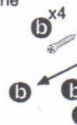

Step 4

• When remove the Speaker tilting it as indicated in this picture.

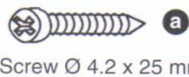
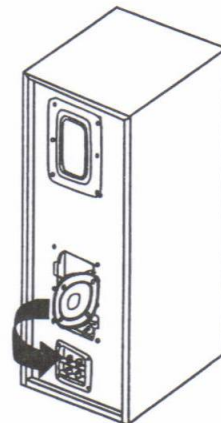

Ref. No. 10	Removal of the Speaker Woofer
Procededure 10	Up Rear

ATTENTION

• When assembly the Passive Radiator put UP mark to upward.

Step 1

• Remove the 6 Screws.

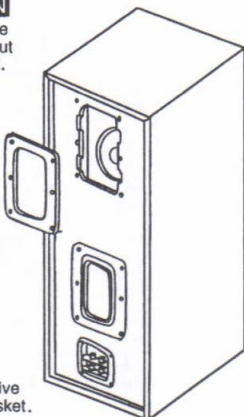
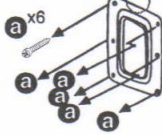

Step 2

• Remove the Passive Radiator and Gasket.

Step 3

• Remove the 4 Screws.

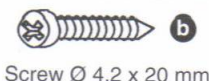
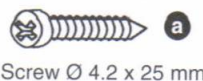
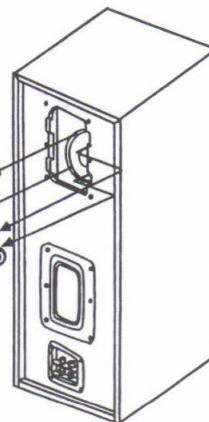
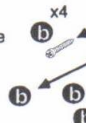

Step 4

- When remove the Speaker tilting it as indicated in this picture.

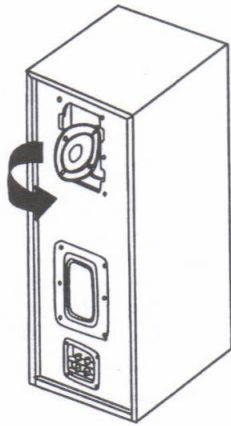

Step 5

- Remove the 2 Speaker Terminals.

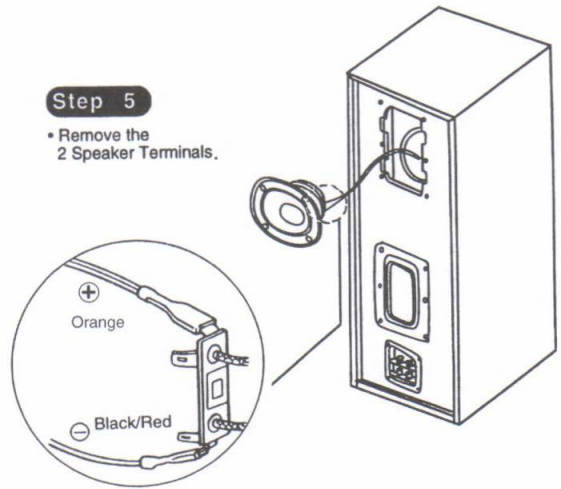

Ref. No. 11

Removal of the Terminal Block

Procededure 11

Step 1

- Remove the 4 Screws.

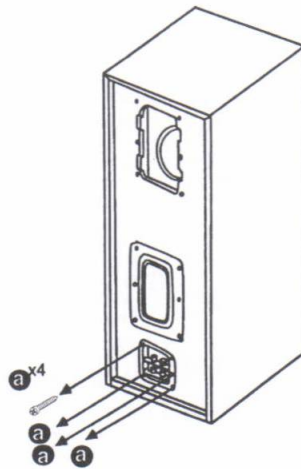

Step 2

- Remove the 2 Terminals HF.

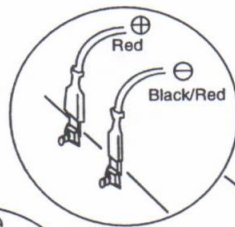

Step 3



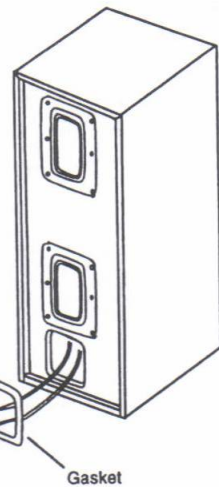
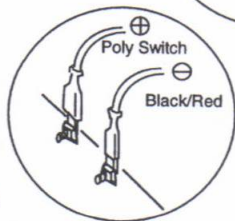

- Remove the 2 Terminals LF.



Screw Ø 4.2 x 25 mm

SCHEMATIC DIAGRAM

(This schematic diagram may be modified at any time with development of new technology.)
 (Este esquema puede ser modificado en cualquier momento con el desarrollo de nuevas tecnologías.)

-    NON POLAR CAPACITOR
-   POLY SWITCH

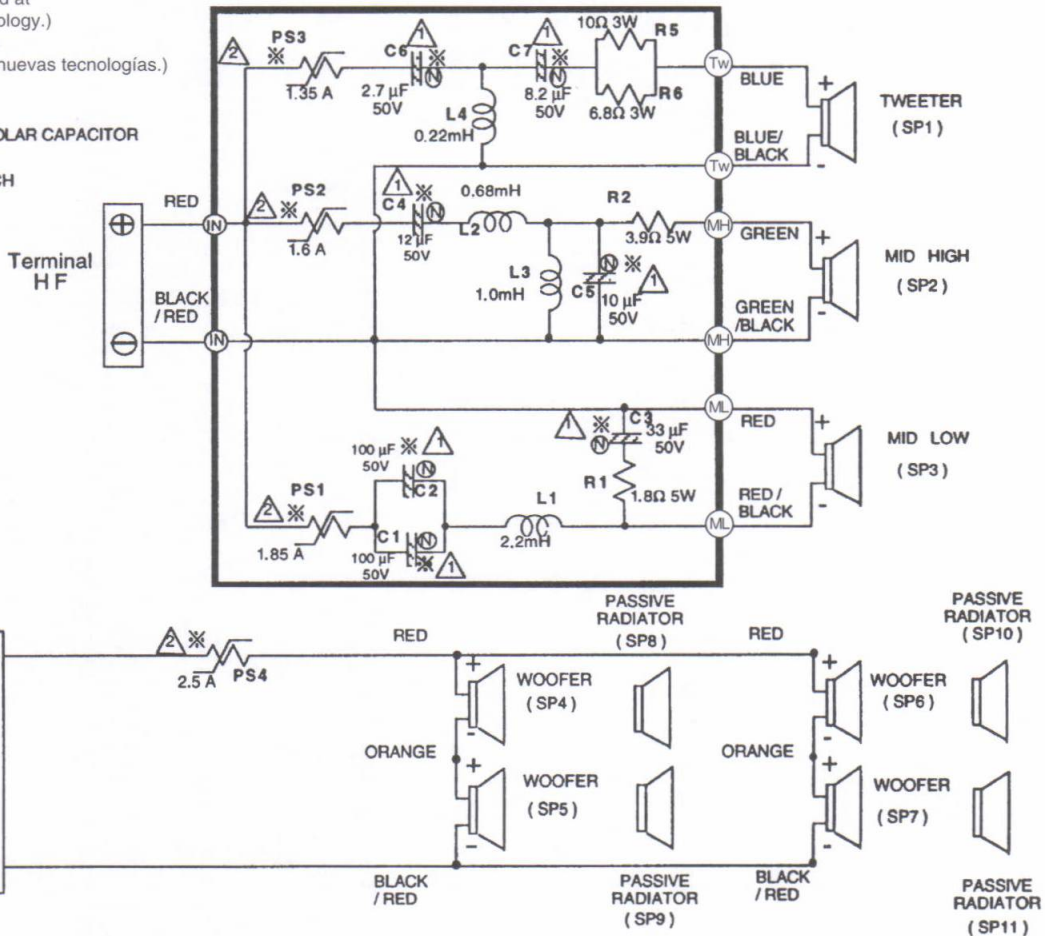

SECTION VIEW

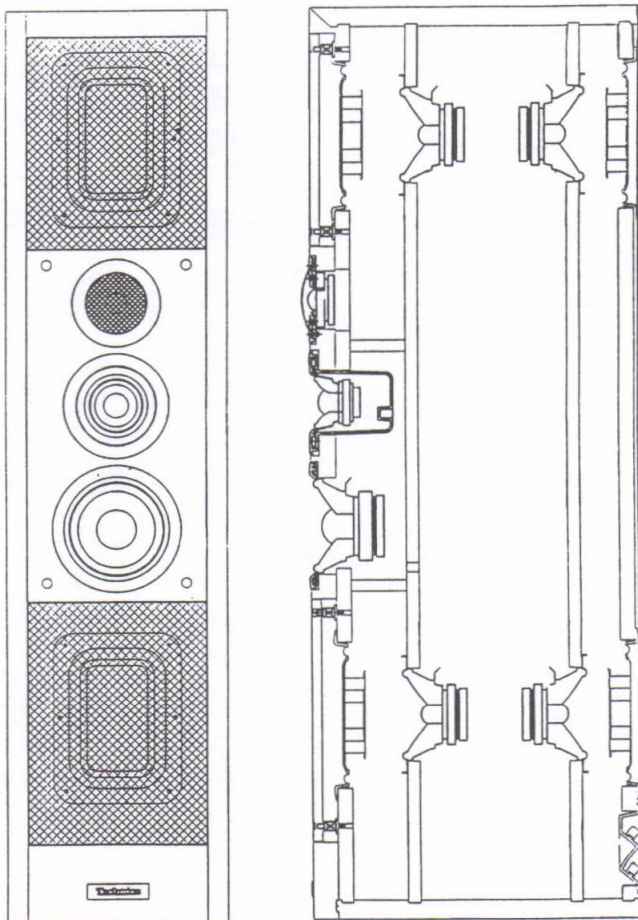

EXPLODED VIEW

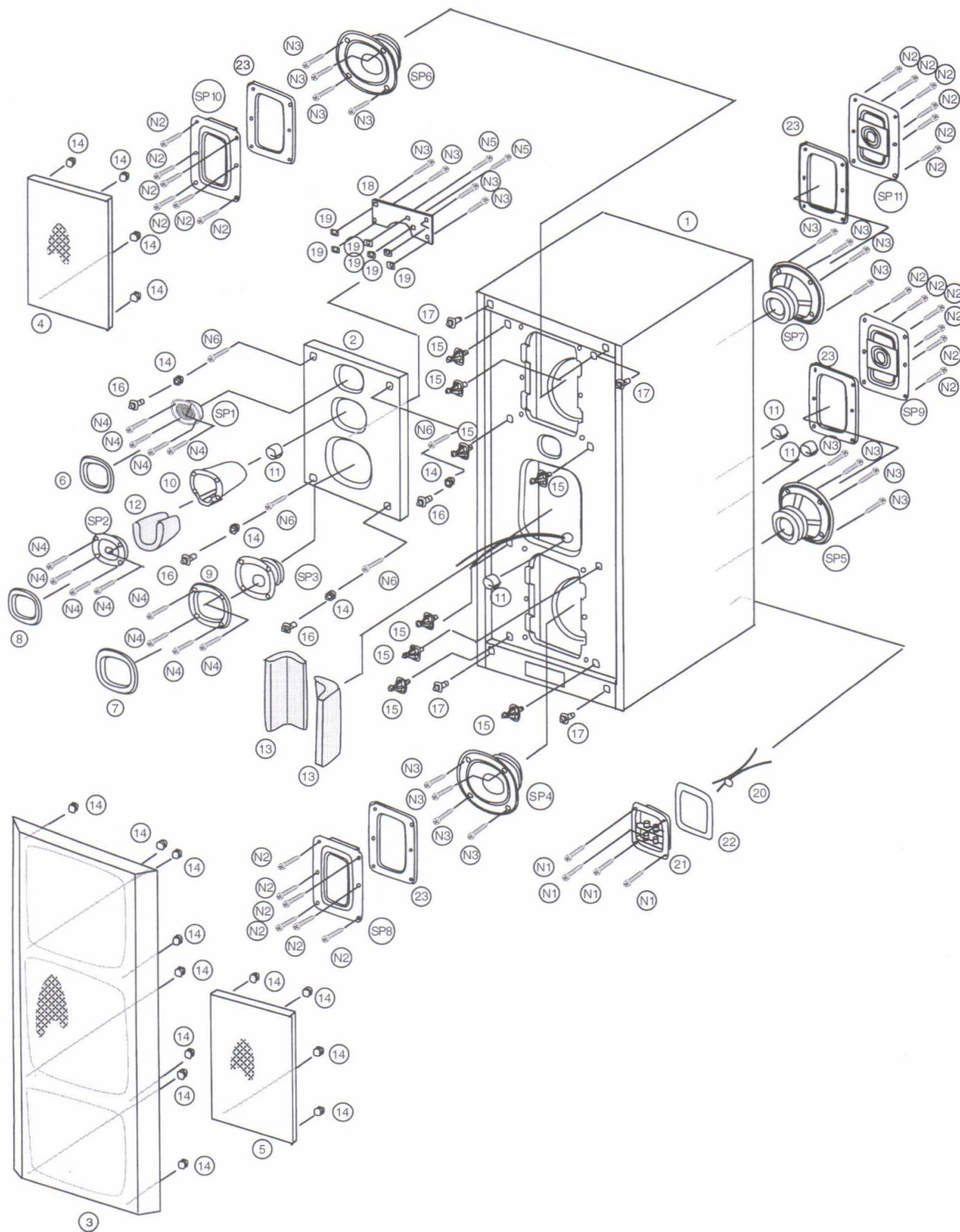

REPLACEMENT PARTS LIST

Notes 1. Part numbers are indicated on most mechanical parts. Please use this part number for parts orders.

2. **PAES** indicates parts that are supplied by PAES.

3. **AD** indicates parts that are supplied by AD. M.E.I.

Notas 1. El código está indicado en la mayoría de las piezas. Por favor, use este código para sus pedidos.

2. La indicación **PAES** significa recambios suministrados a través de PAES.

3. La indicación **AD** significa recambios suministrados a través de AD. M.E.I.

Ref. No.	Part No.	Part Name & Description	Remarks
		SPEAKER (S)	
SP1	EAS25KH104A	SPEAKER (TWEETER)	PAES
SP2	EAS8P347A6	SPEAKER (MID HIGH)	PAES
SP3	EAS14PL339A6	SPEAKER (MID LOW)	PAES
SP4	EAS14PL328C6	SPEAKER (WOOFER)	PAES
SP5	EAS14PL328C6	SPEAKER (WOOFER)	PAES
SP6	EAS14PL328C6	SPEAKER (WOOFER)	PAES
SP7	EAS14PL328C6	SPEAKER (WOOFER)	PAES
SP8	EAS18SY29A6	SPEAKER (PASSIVE RADIATOR)	PAES
SP9	EAS18SY29A6	SPEAKER (PASSIVE RADIATOR)	PAES
SP10	EAS18SY29A6	SPEAKER (PASSIVE RADIATOR)	PAES
SP11	EAS18SY29A6	SPEAKER (PASSIVE RADIATOR)	PAES
		COIL (S)	
L1	SLCSR222J7	CHOQUE COIL 2.2mH	PAES
L2	SLCP681J7	CHOQUE COIL 0.68mH	PAES
L3	SLCSR102J7	CHOQUE COIL 1.0mH	PAES
L4	SLCP221J7	CHOQUE COIL 0.22mH	PAES
		CAPACITOR (S)	
C1	ECEA50TY100KE	NON-POLAR CAPACITOR 100µF 50V	PAES
C2	ECEA50TY100KE	NON-POLAR CAPACITOR 100µF 50V	PAES
C3	ECEA50Y33K	NON-POLAR CAPACITOR 33µF 50V	PAES
C4	ECEA50YT12KE	NON-POLAR CAPACITOR 12µF 50V	PAES
C5	ECEA50YT10KE	NON-POLAR CAPACITOR 10µF 50V	PAES
C6	ECEA50Y2R7KE	NON-POLAR CAPACITOR 2.7µF 50V	PAES
C7	ECEA50YT8R2KE	NON-POLAR CAPACITOR 8.2µF 50V	PAES
		RESISTOR (S)	
R1	ERX5SJ1R8P	RESISTOR 1.8Ω 5W	AD
R2	ERX5SJ3R9P	RESISTOR 3.9Ω 5W	AD
R5	ERG3SJ100P	RESISTOR 10Ω 3W	AD
R6	ERX3SJ6R8P	RESISTOR 6.8Ω 3W	AD
		POLY SWITCH (S)	
PS1	SSBSRXE185	POLY SWITCH 1.85A	PAES
PS2	SSBSRXE160	POLY SWITCH 1.6A	PAES
PS3	SSBSRXE135	POLY SWITCH 1.35A	PAES
PS4	SSBSRXE250	POLY SWITCH 2.5A	PAES

Ref. No.	Part No.	Part Name & Description	Remarks
		CABINET PARTS	
1	SYMPM1000M	CABINET ASS'Y	PAES
2	SCFM1000C60F	FRONT PANEL	PAES
3	SYBPM1000A	NET FRAME (OUTSIDE)	PAES
4	SYBPM1000B	NET FRAME (INSIDE UP)	PAES
5	SYBPM1000C	NET FRAME (INSIDE DOWN)	PAES
6	RMGP0434-T	ORNAMENT SPEAKER TWEETER	PAES
7	RMGP0435-T	ORNAMENT SPEAKER MID LOW	PAES
8	RMGP0436-T	ORNAMENT SPEAKER MID HIGH	PAES
9	RGKP0837-K	PLASTIC RING SPEAKER MID LOW	PAES
10	RMRP1004-K	CAVITY SPEAKER MID HIGH	PAES
11	SHGS8G9071	GASKET	PAES
12	RFAP1113	ABSORBER CAVITY SP. MID HIGH	PAES
13	RFAP0594	ABSORBER	PAES
14	SHG8G9044	NET HOLDER	PAES
15	RMQP0619	CATCH PIN PLASTIC	PAES
16	RMQP0455-1	CATCH PIN BLACK	PAES
17	RMQP0640	CATCH PIN GOLD	PAES
18	SXPM1000	NETWORK ASS'Y	PAES
19	SUDS12	SPACER P.C.B.	PAES
20	REXPM1000LF	CABLE LF ASS'Y	PAES
21	REJ0076	TERMINAL BLOCK	PAES
22	RMQP0589B	GASKET TERMINAL BLOCK	PAES
23	RMQP0589A	GASKET PASSIVE RADIATOR	PAES
		SCREW (S)	
N1	XTNP42+25FG	SCREW TERMINAL BLOCK	PAES
N2	XTN42+25FG	SCREW PASSIVE RADIATOR	PAES
N3	XTN42+20	SCREW SPEAKER WOOFER	PAES
N3	XTN42+20	SCREW P.C.B.	PAES
N4	XTN42+25	SCREW SPEAKER MID HIGH	PAES
N4	XTN42+25	SCREW SPEAKER MID LOW	PAES
N4	XTN42+25	SCREW SPEAKER TWEETER	PAES
N5	XTN42+60	SCREW P.C.B.	PAES
N6	XTN42+32	SCREW FRONT PANEL	PAES
		ACCESORIES	
A1	SQXPM1000	INSTRUCTION BOOK	PAES
A2	XZBA4	BAG	PAES
		PACKING PARTS	
P1	SPGPM1000M	CARTON BOX	PAES
P2	SPSPM1000	PAD	PAES
P3	SPHP35060	SHEET CABINET ASS'Y	PAES
P4	SPHP35030	SHEET NET FRAME	PAES

■ PACKAGING

