

Service Manual

Stereo Power Amplifier

Amplifier

SE-A1000

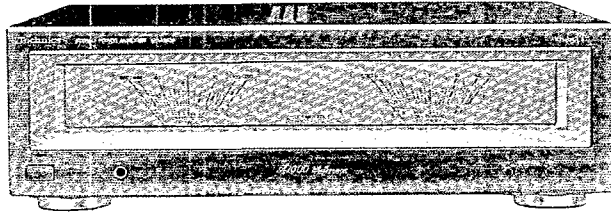

Colour

(K) : Black

Areas

Suffix for Model No.	Area	Colour
(P)	U.S.A.	(K)
(E)	Europe	
(EB)	Britain	
(EG)	Germany and Italy	

[for (P) area code model only]
Specifications (IHF '78)

Rated minimum sine wave RMS power output 20 Hz – 20 kHz both channels driven 0.01% total harmonic distortion	70 W per channel (8 Ω)
Total harmonic distortion rated power at 20 Hz – 20 kHz	0.01% (8 Ω)
Intermodulation distortion (50 Hz:7 kHz = 4:1, SMPTE) rated power	0.007% (8 Ω)
Residual hum and noise	0.3 mV
Damping factor	70 (8 Ω) 35 (4 Ω)
Dynamic headroom	0.3 dB (8 Ω) 0.5 dB (4 Ω)
Headphones output level/impedance	540 mV/330 Ω (Ø 6.3)
Load impedance	
A or B, BI-WIRING	4 – 16 Ω
A and B	8 – 16 Ω
Input sensitivity/impedance	
Power amp. direct	90 mV (1 V, IHF '66)/33 kΩ
S/N	
Power amp. direct	95 dB (110 dB, IHF '66)
Frequency response	
Power amp. direct	5 Hz – 70 kHz (+0, –3 dB) +0 dB, –0.5 dB (20 Hz – 20 kHz)
■ GENERAL	
Power consumption	235 W
Power supply	AC 120 V, 60 Hz
Dimensions (W × H × D)	430 × 136 × 344 mm (16-59/64" × 5-23/64" × 13-35/64")
Weight	9.8 kg (21.6 lb)

[for (E), (EB) and (EG) area code model]
Specifications (DIN 45 500)

20 Hz – 20 kHz continuous power output both channels driven	2 × 70 W (8 Ω)
1 kHz continuous power output both channels driven (THD: 1%)	2 × 85 W (8 Ω) 2 × 120 W (4 Ω)
63 Hz – 12.5 kHz continuous power output both channels driven (THD: 0.7%)	2 × 80 W (8 Ω) 2 × 105 W (4 Ω)
Total harmonic distortion rated power at 20 Hz – 20 kHz	0.01% (8 Ω)
Intermodulation distortion (50 Hz: 7 kHz = 4:1, SMPTE)	0.007% (8 Ω)
Residual hum and noise	0.3 mV
Damping factor	70 (8 Ω) 35 (4 Ω)
Headphones output level/impedance	540 mV/330 Ω (Ø 6.3)
Load impedance	
A or B, BI-WIRING	4 Ω – 16 Ω
A and B	8 Ω – 16 Ω
Input sensitivity/impedance	1 V/33 kΩ
S/N (rated power, 4 Ω)	95 dB (110 dB, IHF '66)
Frequency response	
Power amp. direct	5 Hz – 70 kHz (+0, –3 dB) +0 dB, –0.5 dB (20 Hz – 20 kHz)
■ GENERAL	
Power consumption	280 W
Power supply	
For (E) and (EG) areas	50 Hz/60 Hz AC, 230 V
For (EB) area	50 Hz/60 Hz AC, 230 V – 240 V
Dimensions (W × H × D)	430 × 136 × 344 mm
Weight	9.8 kg

Notes:

- Design and specifications are subject to change without notice.
Weight and dimensions are approximate.
- Total harmonic distortion is measured by the digital spectrum analyzer.

⚠ WARNING

This service information is designed for experienced repair technicians only and is not designed for use by the general public. It does not contain warnings or cautions to advise non-technical individuals of potential dangers in attempting to service a product. Products powered by electricity should be serviced or repaired only by experienced professional technicians. Any attempt to service or repair the product or products dealt with in this service information by anyone else could result in serious injury or death.

Technics®

© 1995 Matsushita Electric Industrial Co., Ltd.
All rights reserved. Unauthorized copying
and distribution is a violation of law.

■ Contents

	Page		Page
Safety Precaution	2	Measurements and Adjustments	11
Before Repair	2	Schematic Diagram	12~16
Protection Circuitry	2	Printed Circuit Board Diagram	17~21
Accessories	3	Wiring Connection Diagram	22
Caution for AC Mains Lead	3	Block Diagram	23
Connections	4, 5	Replacement Parts List	24~27, 30
Front Panel Controls	5	Cabinet Parts Location	28, 29
Operations	6	Packaging	30
Operation Check and Main Component Replacement Procedures	7~11		

■ Safety Precaution

[for (P) area code model only]

1. Before servicing, unplug the power cord to prevent an electric shock.
2. When replacing parts, use only manufacturer's recommended components for safety.
3. Check the condition of the power cord. Replace if wear or damage is evident.
4. After servicing, be sure to restore the lead dress, insulation barriers, insulation papers, shields, etc.
5. Before returning the serviced equipment to the customer, be sure to make the following insulation resistance test to prevent the customer from being exposed to a shock hazard.

● INSULATION RESISTANCE TEST

1. Unplug the power cord and short the two prongs of the plug with a jumper wire.
2. Turn on the power switch.
3. Measure the resistance value with ohmmeter between the jumpered AC plug and each exposed metal cabinet part, such as screwheads antenna, control shafts, handle brackets, etc. Equipment with antenna terminals should read between 3 MΩ and 5.2 MΩ to all exposed parts. (Fig. A)
Equipment without antenna terminals should read approximately infinity to all exposed parts. (Fig. B)

Note: Some exposed parts may be isolated from the chassis by design. These will read infinity.

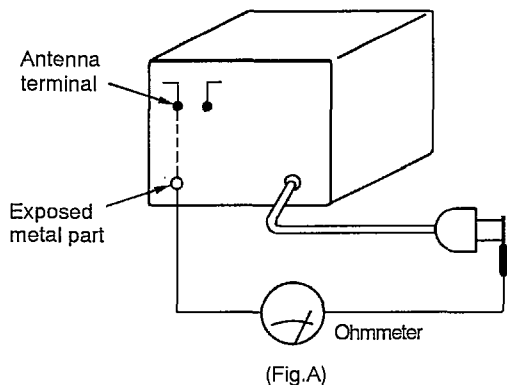

Resistance = 3 MΩ — 5.2 MΩ

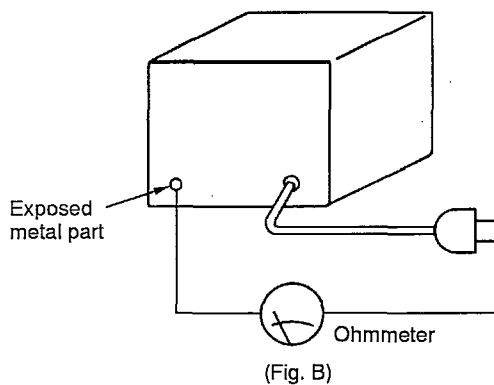

Resistance = Approx. ∞

4. If the measurement is outside the specified limits, there is a possibility of a shock hazard. The equipment should be repaired and rechecked before it is returned to the customer.

■ Before Repair

- (1) Turn off the power supply. Using a 10 Ω, 10 W resistor, connect both ends of power supply capacitors (C701, C702) in order to discharge the voltage.
- (2) Before turning the power supply on, after completion of repair, slowly apply the primary voltage by using a power supply voltage controller to make sure that the consumed current at 50/60 Hz in NO SIGNAL mode should be shown below with respect to supply voltage 120 V/230 V/240 V.

Power supply voltage	AC 120 V, 60 Hz	AC 230 V, 50 Hz	AC 240 V, 50 Hz
Consumed current	300 ~ 600 mA	160 ~ 320 mA	160 ~ 320 mA

■ Protection Circuitry

The protection circuitry may have operated if either of the following conditions is noticed:

- No sound is heard when the power is switched ON.
- Sound stops during a performance.

The function of this circuitry is to prevent circuitry damage if, for example, the positive and negative speaker connection wires are "shorted", or if speaker systems with an impedance less than the indicated rated impedance of this unit are used.

If this occurs, follow the procedure outlined below:

1. Switch OFF the power.
2. Determine the cause of the problem and correct it.
3. Switch ON the power once again.

Note:

When the protection circuitry functions, the unit will not operate unless the power is first switched OFF and then ON again.

■ Accessories

- AC power supply cord
(P) area : (SJA172) 1 (E, EG) areas : (RJA0019-2K) 1 (EB) area : (VJA0733) 1

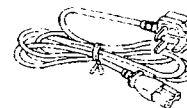
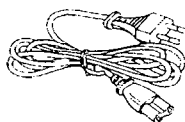
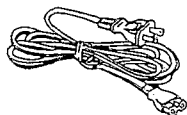

■ Caution for AC Mains Lead



[for (EB) area code model only]

For your safety, please read the following text carefully.

This appliance is supplied with a moulded three pin mains plug for your safety and convenience.

A 5-ampere fuse is fitted in this plug.

Should the fuse need to be replaced please ensure that the replacement fuse has a rating of 5-ampere and that it is approved by ASTA or BSI to BS1362.

Check for the ASTA mark  or the BSI mark  on the body of the fuse.

If the plug contains a removable fuse cover you must ensure that it is refitted when the fuse is replaced.

If you lose the fuse cover the plug must not be used until a replacement cover is obtained.

A replacement fuse cover can be purchased from your local dealer.

CAUTION!

IF THE FITTED MOULDED PLUG IS UNSUITABLE FOR THE SOCKET OUTLET IN YOUR HOME THEN THE FUSE SHOULD BE REMOVED AND THE PLUG CUT OFF AND DISPOSED OF SAFELY.

THERE IS A DANGER OF SEVERE ELECTRICAL SHOCK IF THE CUT OFF PLUG IS INSERTED INTO ANY 13-AMPERE SOCKET.

If a new plug is to be fitted please observe the wiring code as shown below.

If in any doubt please consult a qualified electrician.

IMPORTANT

The wires in this mains lead are coloured in accordance with the following code:

Blue: Neutral

Brown: Live

As the colours of the wires in the mains lead of this appliance may not correspond with the coloured markings identifying the terminals in your plug, proceed as follows:

The wire which is coloured BLUE must be connected to the terminal in the plug which is marked with the letter N or coloured BLACK.

This apparatus was produced to BS 800.

The wire which is coloured BROWN must be connected to the terminal in the plug which is marked with the letter L or coloured RED.

Under no circumstances should either of these wires be connected to the earth terminal of the three pin plug, marked with the letter E or the Earth Symbol .

Before use

Removal the connector cover as follows.

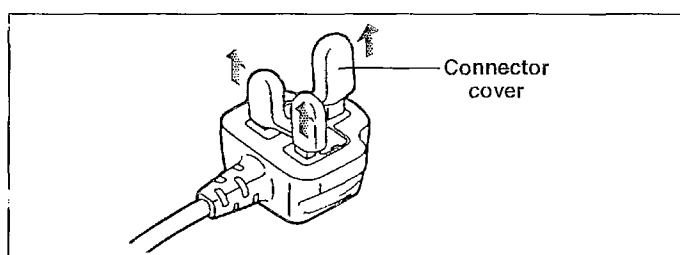

How to replace the fuse

1. Remove the fuse cover with a screwdriver.

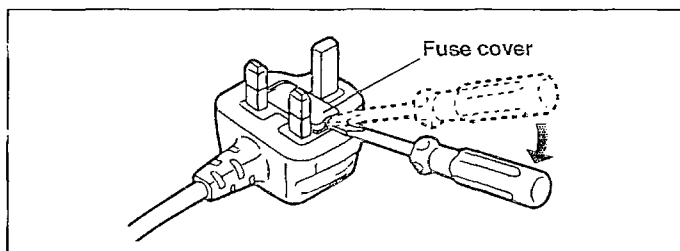

2. Replace the fuse and attach the fuse cover.

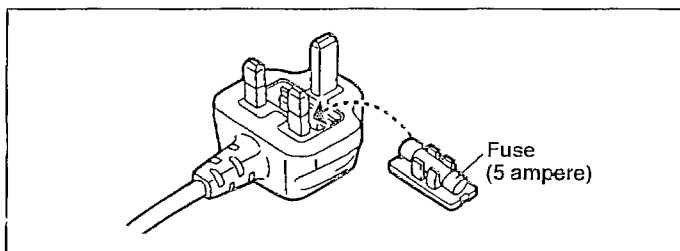

■ Connections

Before making connections, be sure that the power to this unit and all other equipment is first turned off.

Note

This unit has ventilation holes on its top surface. Take care, therefore, not to obstruct the ventilation holes by placing other audio equipment, books, etc. on top of this unit.

Connecting to a control amplifier

[for all area code model]

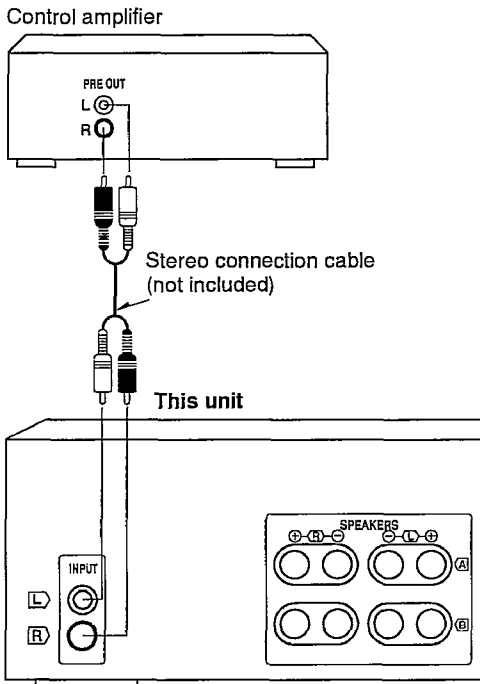

[for (E), (EB) and (EG) area code model]

When connecting to the Technics SU-C1000

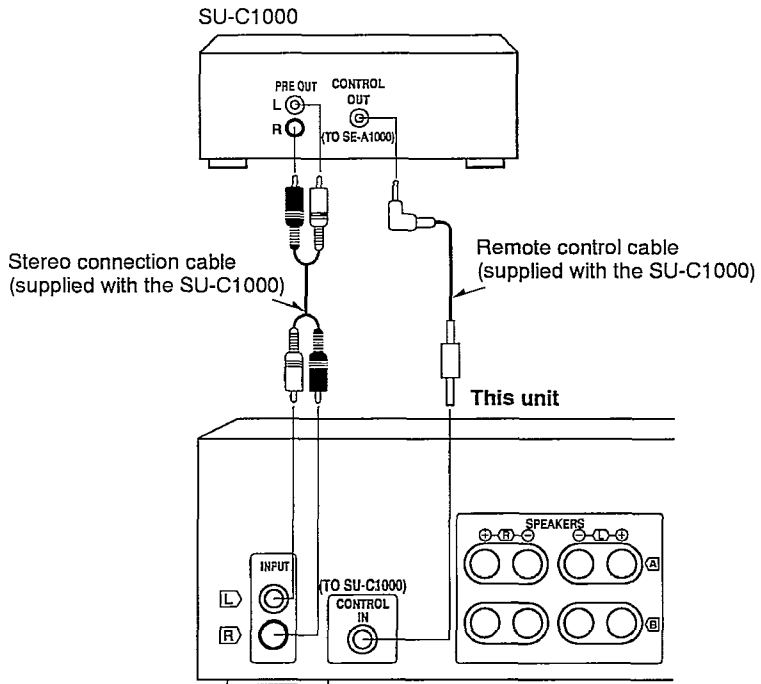

Connecting the speakers

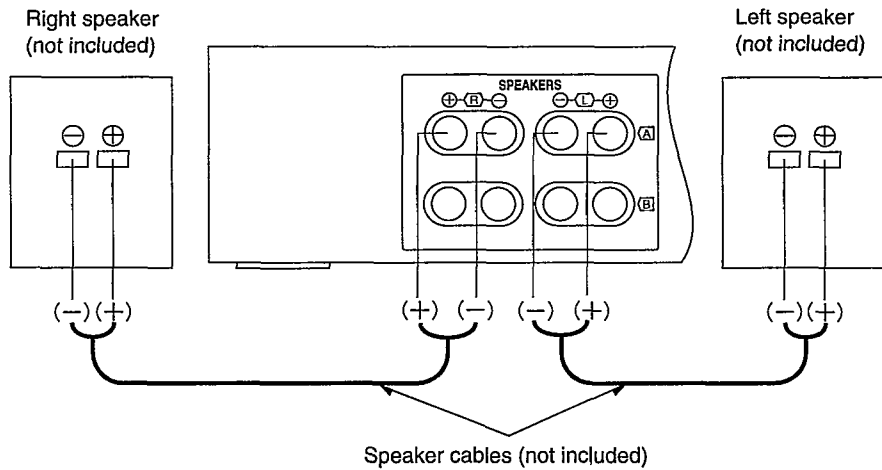

10 mm → Twist

NO

CAUTION

To prevent damage to circuitry, never short-circuit the positive (+) and negative (-) speaker wires.

The speaker wires which are connected to the positive (+) terminals of the amplifier should be connected to the positive (+) terminals of the speakers. The negative (-) terminals should be connected in a similar way.

Speaker impedance

- When only the "A" or only the "B" terminals are used: 4-16 Ω
- When both the "A" and the "B" terminals are used simultaneously: 8-16 Ω

"B" terminals

For connection to a second pair of speakers.

Connecting the power supply

Connect the power supply only after all other connections have been made.

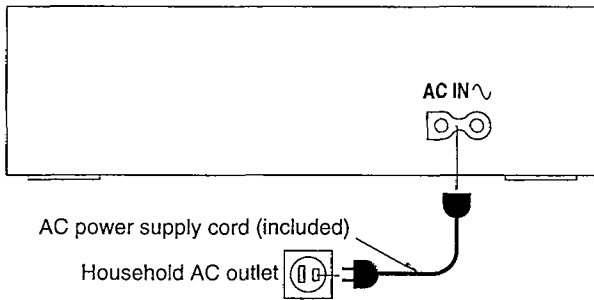

Cooling fan

The cooling fan operates at high power output levels only.

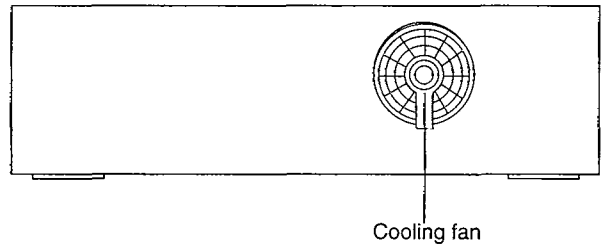

Front Panel Controls

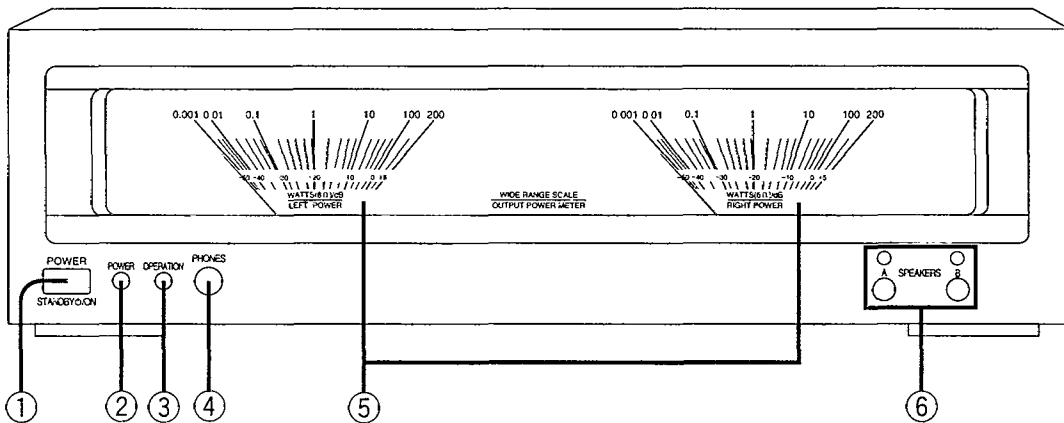

No.	Name
①	Power "STANDBY /ON" switch (POWER, STANDBY /ON) Press to switch the unit from on to standby mode or vice versa. In standby mode, the unit is still consuming a small amount of power.
②	Power indicator (POWER)
③	Operation indicator (OPERATION) When the power indicator lights up, this indicator illuminates after about 4 seconds when the unit is in the operating condition. If the (+) and (-) wires of the speaker cables are shorted, or if a circuit abnormality such as DC voltage in the power output to the speakers is detected, the protection circuit will operate and the "OPERATION" indicator will turn off.

No.	Name
④	Headphones jack (PHONES) (ϕ 6.3, 330 Ω)
⑤	Power meters Indicate the output (watts) of this unit. When speakers having an impedance of 8 Ω are connected, the output level will be as indicated. However, if the speaker impedance is 16 Ω , the output level will be one-half the indicated value, and if the impedance is 4 Ω , the output level will be double the indicated value. $\text{Actual output} = \text{meter indication} \times \frac{8 (\Omega)}{\text{impedance of the speakers } (\Omega)}$
⑥	Speaker select buttons/indicators (SPEAKERS)

■ Operations

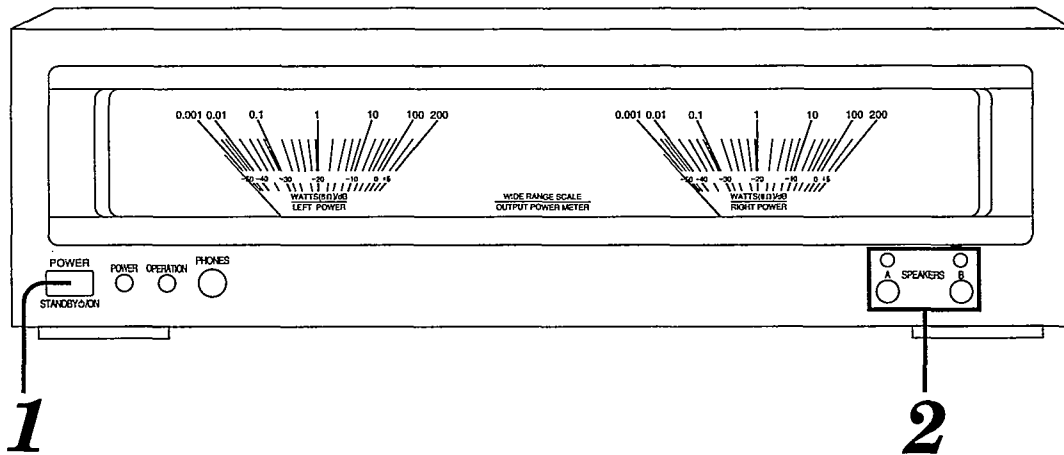

Before operating this unit.

1. Set the volume on the control amplifier to the minimum position.
2. Switch on the power of the control amplifier.

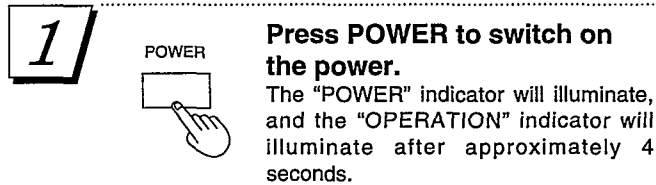

[for (E), (EB) and (EG) area code model]

(If the SU-C1000 control amplifier is connected to this unit)

Once this unit has been turned on, both amplifiers can then be turned on or to the standby mode using POWER on the control amplifier.

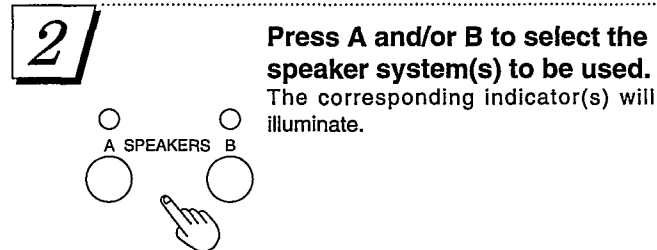

To listen through headphones

Decrease the volume at the control amplifier, and then connect the 6.3-mm phone plug stereo-type headphones.

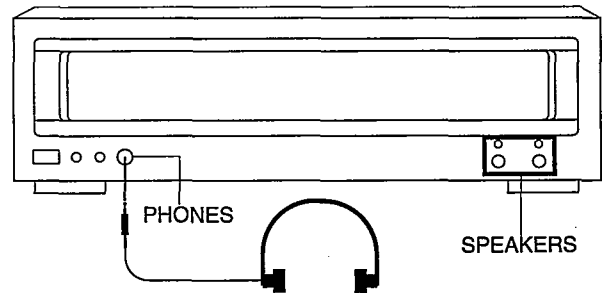

Headphones (not included)

If sound from speakers is not wanted, press SPEAKERS (A) and/or (B) to turn off the speaker indicators.

Note

Avoid listening for prolonged periods of time to prevent hearing damage.



After listening is finished

1. Decrease the volume at the control amplifier.
2. First switch this unit to the standby position, and then do the same for the control amplifier.

[for (E), (EB) and (EG) area code model]

(When connected to the SU-C1000)

Press POWER on the SU-C1000 to switch both amplifiers to the standby condition.

■ Operation Check and Main Component Replacement Procedures

- NOTE**
1. This section describes procedures for checking the operation of the major printed circuit boards and replacing the main components.
 2. For reassembly after operation checks or replacement, reverse the respective procedures. Special reassembly procedures are described only when required.
 3. Select items from the following index when checks or replacement are required.
 4. Illustrated screws are equivalent to actual size.
 5. Refer the parts No. on the page of "Main Component Replacement Procedures", if necessary.

● Contents

	Page.
•Checking Procedure for each P.C.B.	
1.Checking for the main P.C.B..	7,8.
•Main Component Replacement Procedures	
1.Replacement for the foot.	9.
2.Replacement for the power IC and regulator transistor.	9,10.
3.Replacement for the fan motor.	10.
4.Replacement for the output power meter.	11.

■ Checking Procedure for each P.C.B.

1. Checking for the main P.C.B.

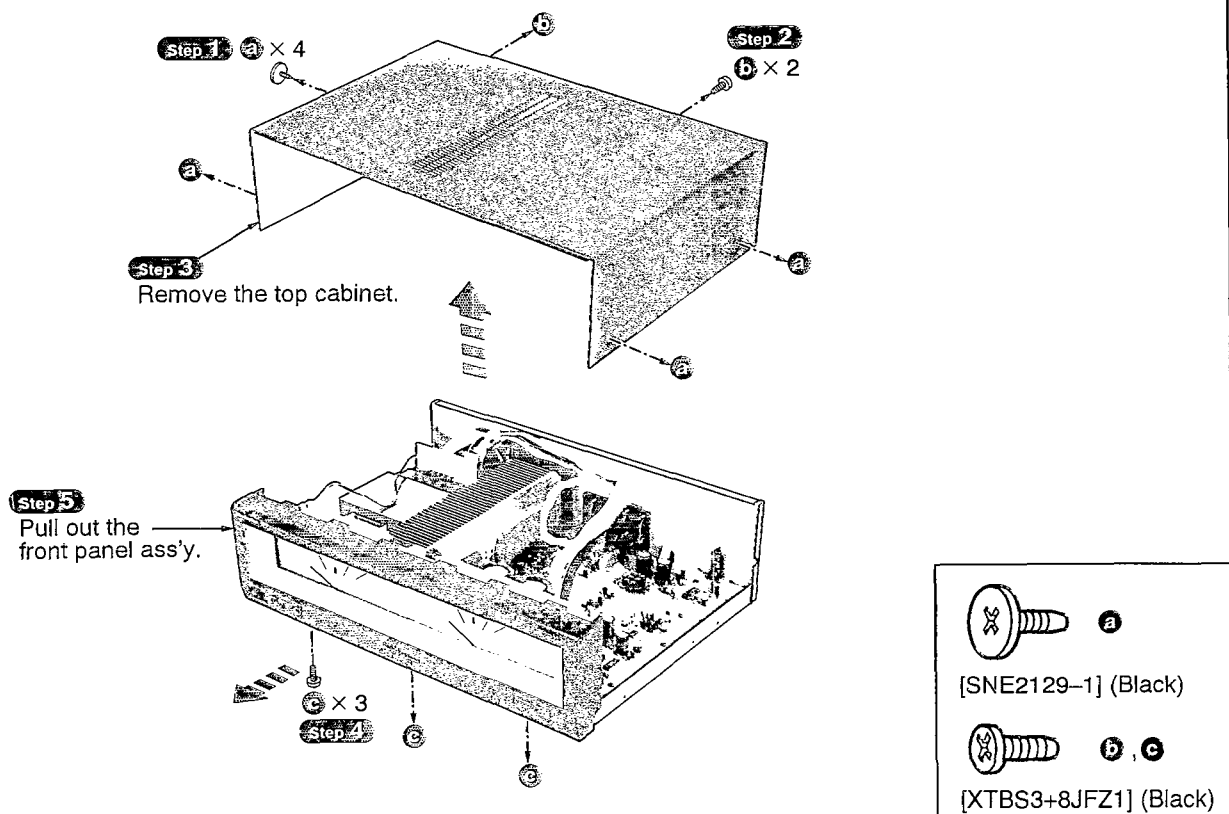

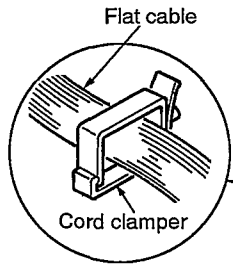

Step 6
Remove the flat cable from cord clamer.

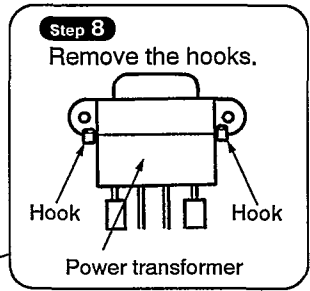
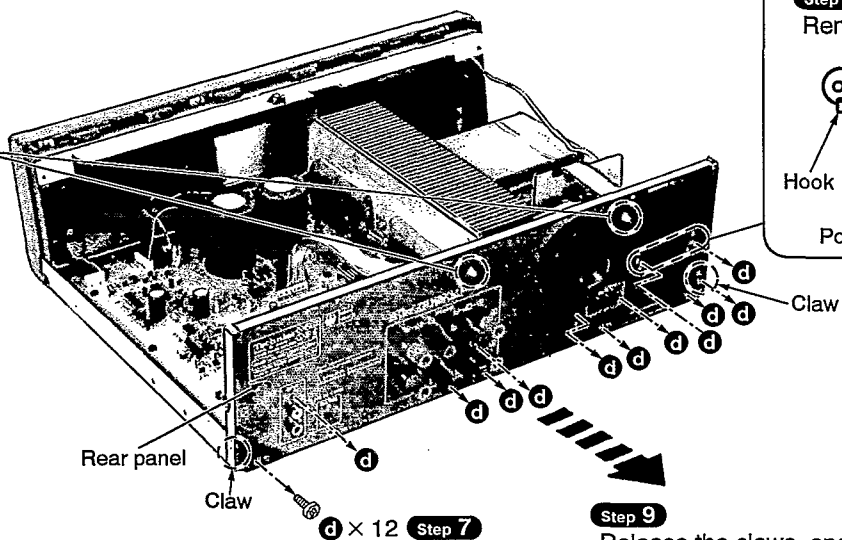

Step 9
Release the claws, and then remove the rear panel.

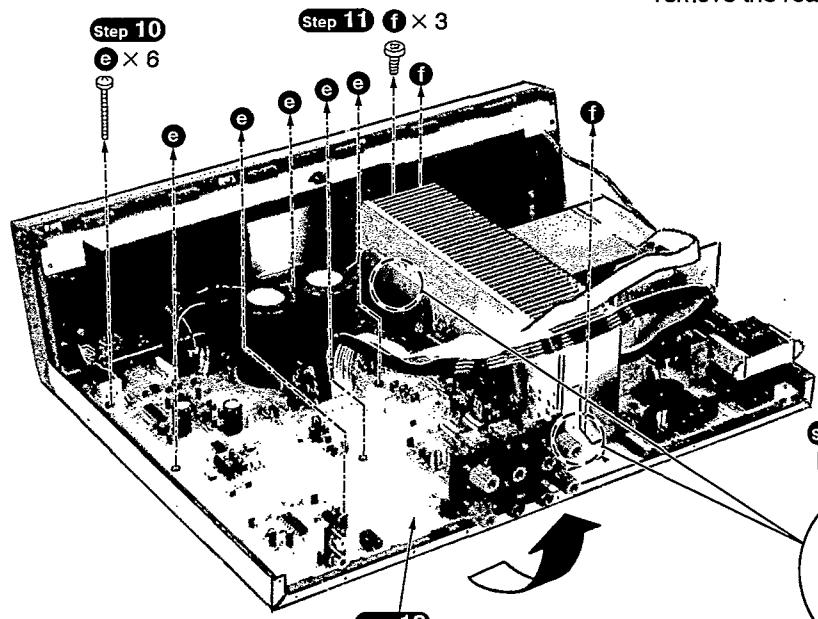



• Check the main P.C.B. as shown below.

Step 13
Raise the main P.C.B.

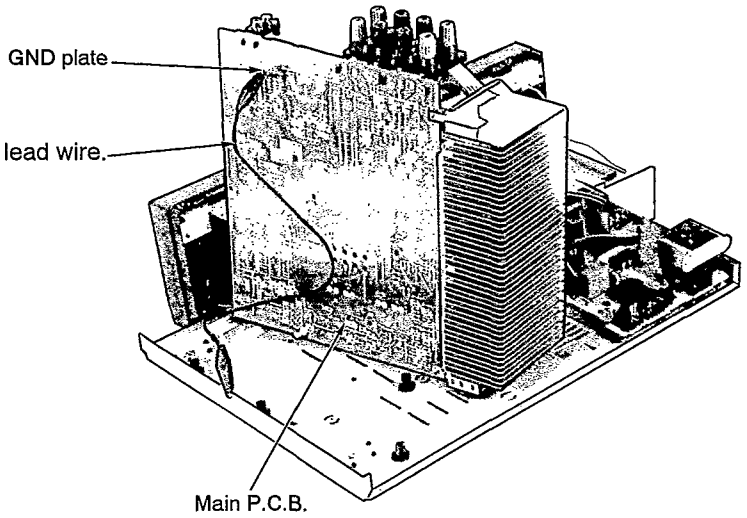
Step 14
Connect the lead wire.

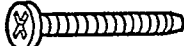

-  **d**
[XTBS3+8JFZ1](Black)
-  **e**
[XTB3+20JFZ](Black)
-  **f**
[XTB3+8JFZ](Black)

Main Component Replacement Procedures

1. Replacement for the foot

• Follow the **Step 1** ~ **Step 13** in item 1 on checking procedure for each P.C.B. on pages 7 and 8.

Step 3 Remove the 4 heat melted posts on the bottom chassis ass'y with a pair of nippers or similar tool.

Step 4 To replace the foot(RKA0053-A) on the bottom chassis ass'y melt the 4 posts with a soldering iron or install it with a screw (XTB3+6J)

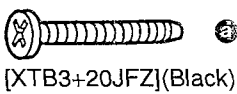
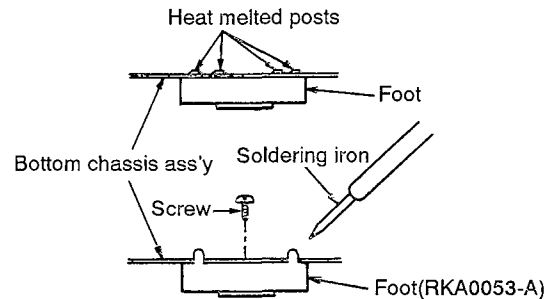
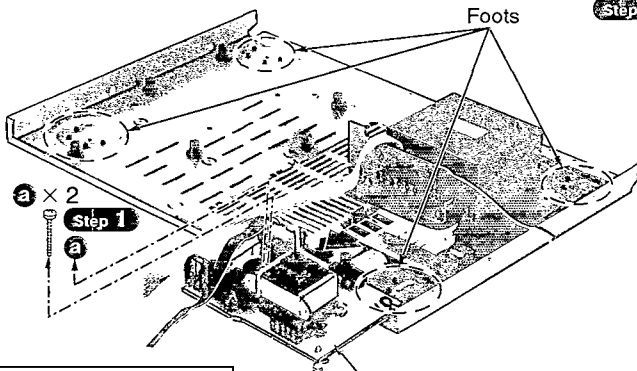

Step 2
Remove the power supply P.C.B.

2. Replacement for the power IC and regulator transistor

• Follow the **Step 1** ~ **Step 3** in item 1 on checking procedure for each P.C.B. on page 7.

Step 1 Cut the joints as shown below.(6 portions)

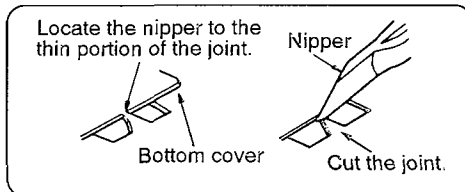

Step 2 Fold the joints.(6 portions)

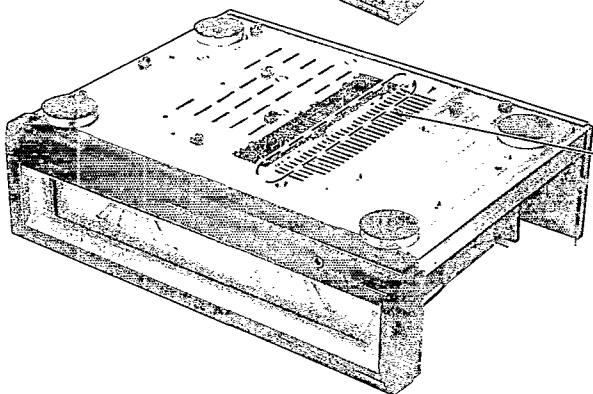
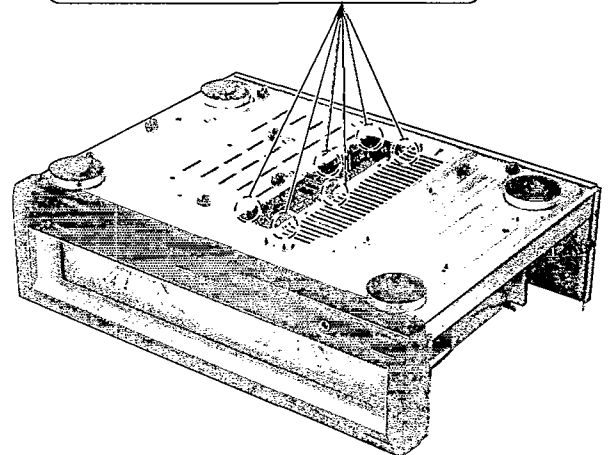
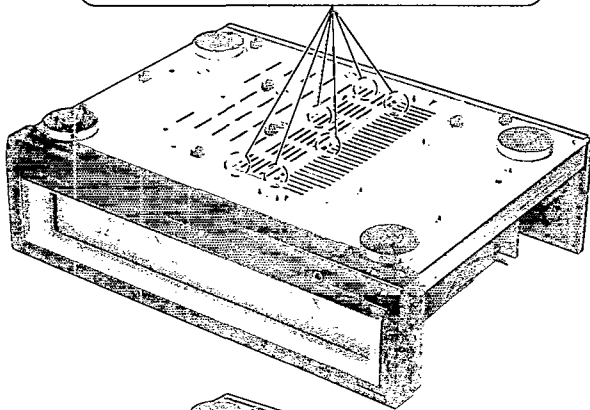
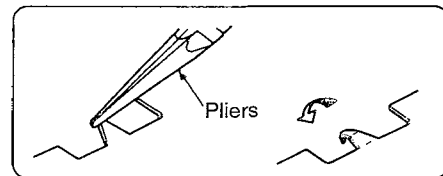

Step 3
Unsolder the terminals of power IC and regulator transistor.

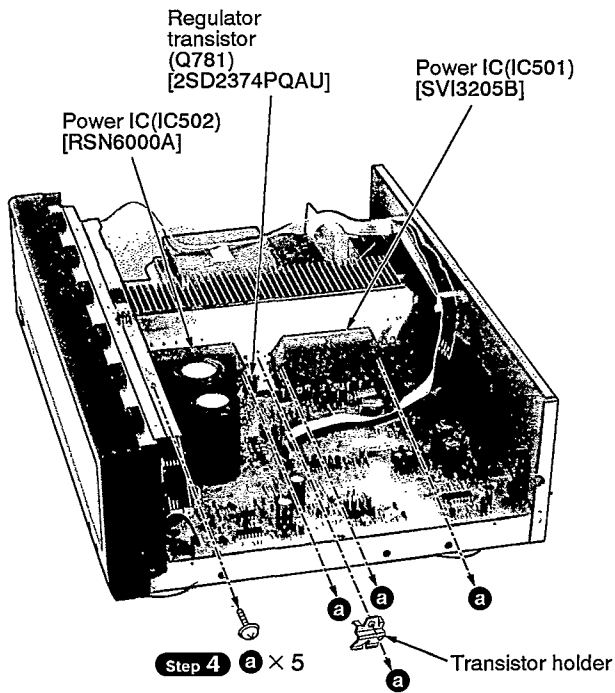

Installation of the bottom cover after replacement

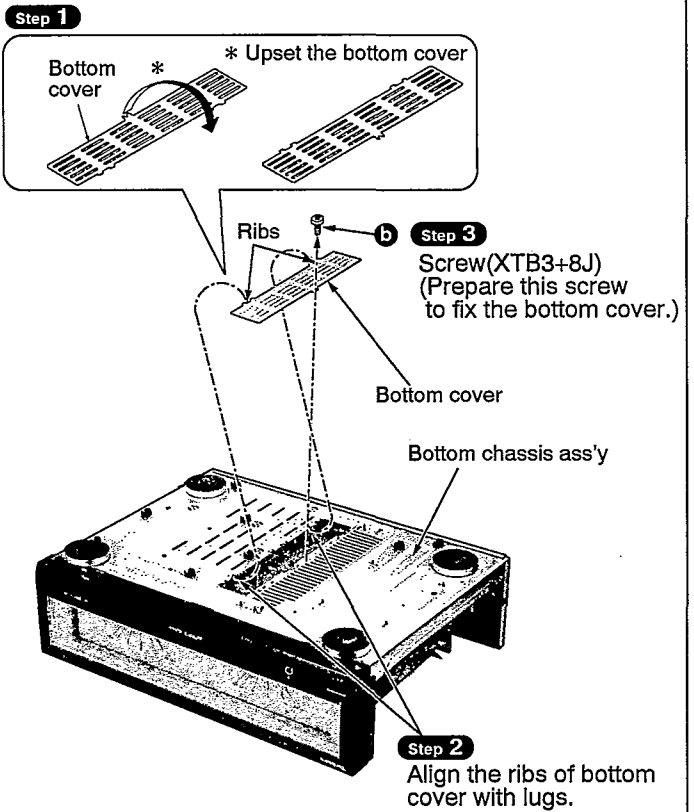

CAUTION

1. After replceing the power IC or regulator transistor, apply a sufficient quantity of compound grease (RFKX0002) between the heat sink and the power IC or regulator transistor (Radiation of power IC).
2. Tighten enough the screws (a) after replacing the power IC and regulator transistor. Otherwise, the heat rabiation works little.

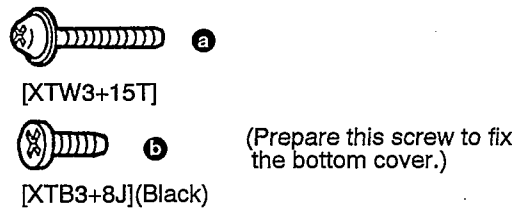

3. Replacement for the fan motor

• Follow the Step 1 ~ Step 9 in item 1 on checking procedure for each P.C.B. on pages 7 and 8.

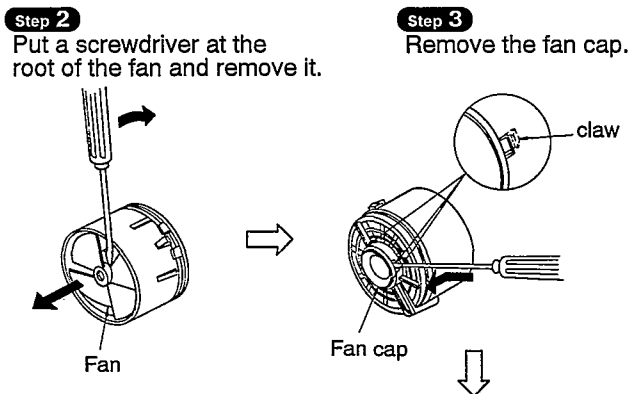
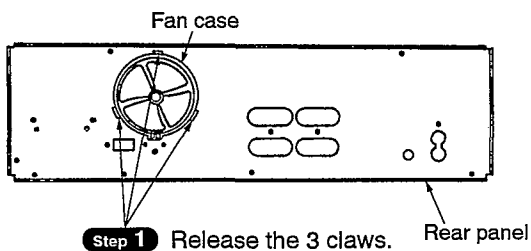

NOTE

When replacing the fan motor, align the boss of the fan case with the hole of the fan motor.

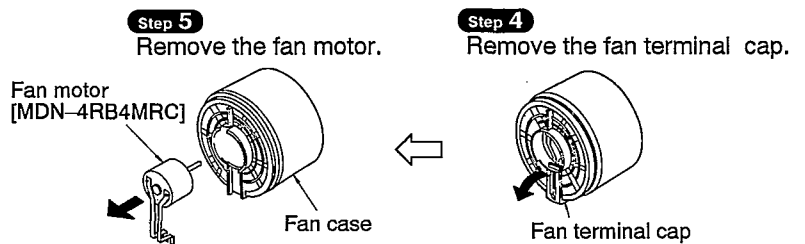
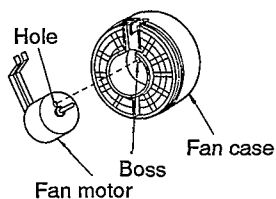

4. Replacement for the meter ass'y

• Follow the **Step 1** ~ **Step 5** in item 1 on checking procedure for each P.C.B. on page 7.

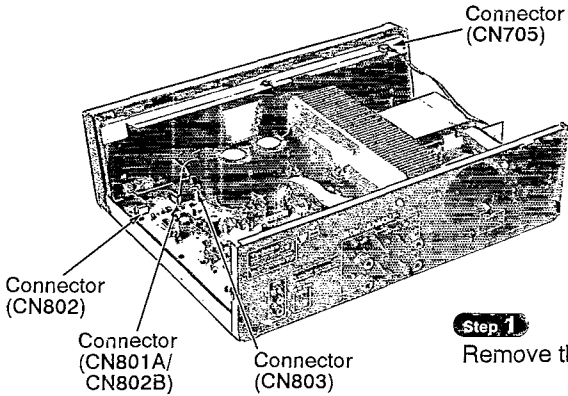
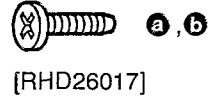

Step 1
Remove the 4 connectors.

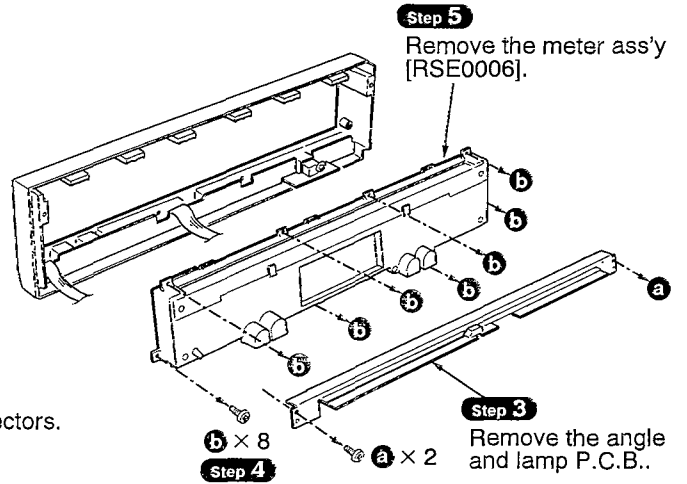

Step 5
Remove the meter ass'y [RSE0006].

Step 3
Remove the angle and lamp P.C.B..

Step 4
b × 8
a × 2

Measurements and Adjustments

Measuring Instruments and Special Tools

- AC electronic voltmeter (AC EVM)
- AF oscillator

Power Meter Adjustment

1. Test equipment connection is shown in Fig. 1.
2. Before turning ON the set, adjust VR909 (L-ch) and VR910 (R-ch) to mechanical center position (shown in Fig. 2).
3. Turn the power ON, make sure that the power meter is mechanically adjusted to 0 point (shown in Fig. 3).
4. Apply a 1 kHz signal to the input terminal so that the output voltage of speaker terminal is 8.94 V (adjust the signal level with the attenuator of AF oscillator).
5. Adjust VR909 (L-ch) and VR910 (R-ch) so that the power meter indicates 10 W (shown in Fig. 4).

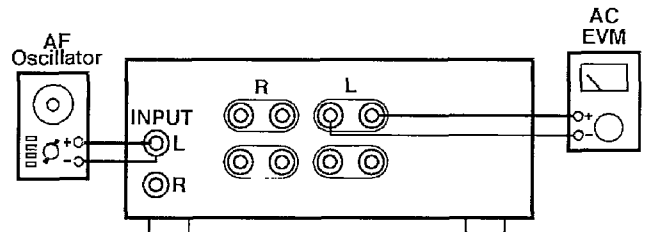

Fig. 1

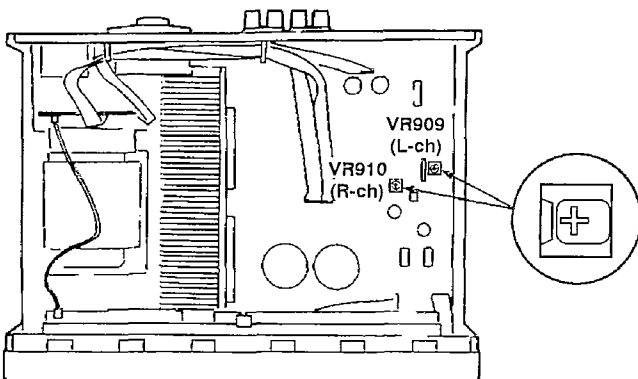

Fig. 2

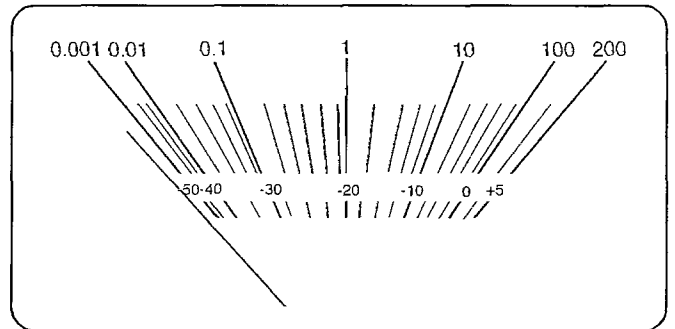

Fig. 3

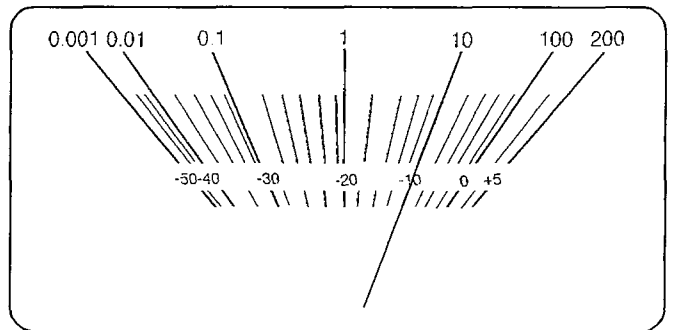

Fig. 4

■ Schematic Diagram

	Page
A MAIN CIRCUIT	13~16
B SP. SWITCH CIRCUIT	16
C HEADPHONES JACK CIRCUIT	16
D POWER SWITCH CIRCUIT	16
E LAMP (RIGHT) CIRCUIT	16
F LAMP (LEFT) CIRCUIT	16
G POWER TRANSFORMER CIRCUIT	16
H POWER SUPPLY CIRCUIT	16

• This schematic diagram may be modified at any time with the development of new technology.

Notes:

- **S801** : Power "STANDBY ϕ /ON" switch (POWER, STANDBY ϕ /ON)
- **S802** : Speaker select switch (SPEAKER A)
- **S803** : Speaker select switch (SPEAKER B)
- **VR909** : Power meter adjustment VR (L ch)
- **VR910** : Power meter adjustment VR (R ch)

• Indicated voltage values are the standard values for the unit measured by the DC electronic circuit tester (high-impedance) with the chassis taken as standard. Therefore, there may exist some errors in the voltage values, depending on the internal impedance of the DC circuit tester.
No mark: Power ON

• Voltage and signal line

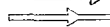
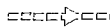
-  : Source Signal Line
-  : Positive Voltage Line
-  : Negative Voltage Line

• Important safety notice:

Components identified by \triangle mark have special characteristics important for safety.

Furthermore, special parts which have purposes of fire-retardant (resistors), high-quality sound (capacitors), low-noise (resistors), etc. are used. When replacing any of components, be sure to use only manufacturer's specified parts shown in the parts list.

• **Caution!**

IC and LSI are sensitive to static electricity.
Secondary trouble can be prevented by taking care during repair.
Cover the parts boxes made of plastics with aluminum foil.
Ground the soldering iron.
Put a conductive mat on the work table.
Do not touch the legs of IC or LSI with the fingers directly.

[for (P) area code model only]

CAUTION: FOR CONTINUED PROTECTION AGAINST FIRE HAZARD, REPLACE ONLY WITH SAME TYPE 6.3 A 125 V FUSES.



RISK OF FIRE-REPLACE FUSE AS MARKED.

MAIN CIRCUIT (P.C.Board: on pages 18,19)

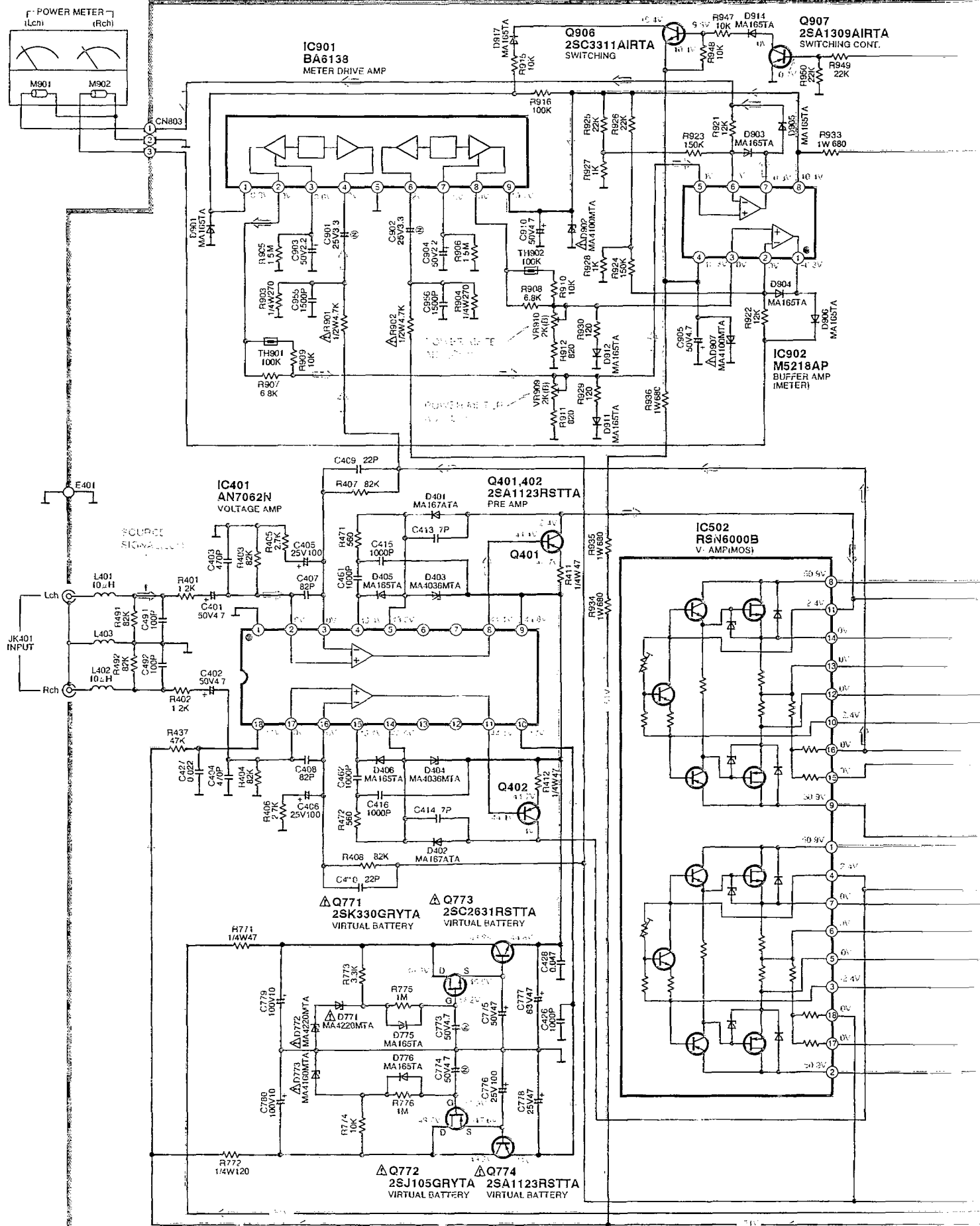

→ : Positive Voltage Line

⇄ : Negative Voltage Line

→ : Source Signal Line

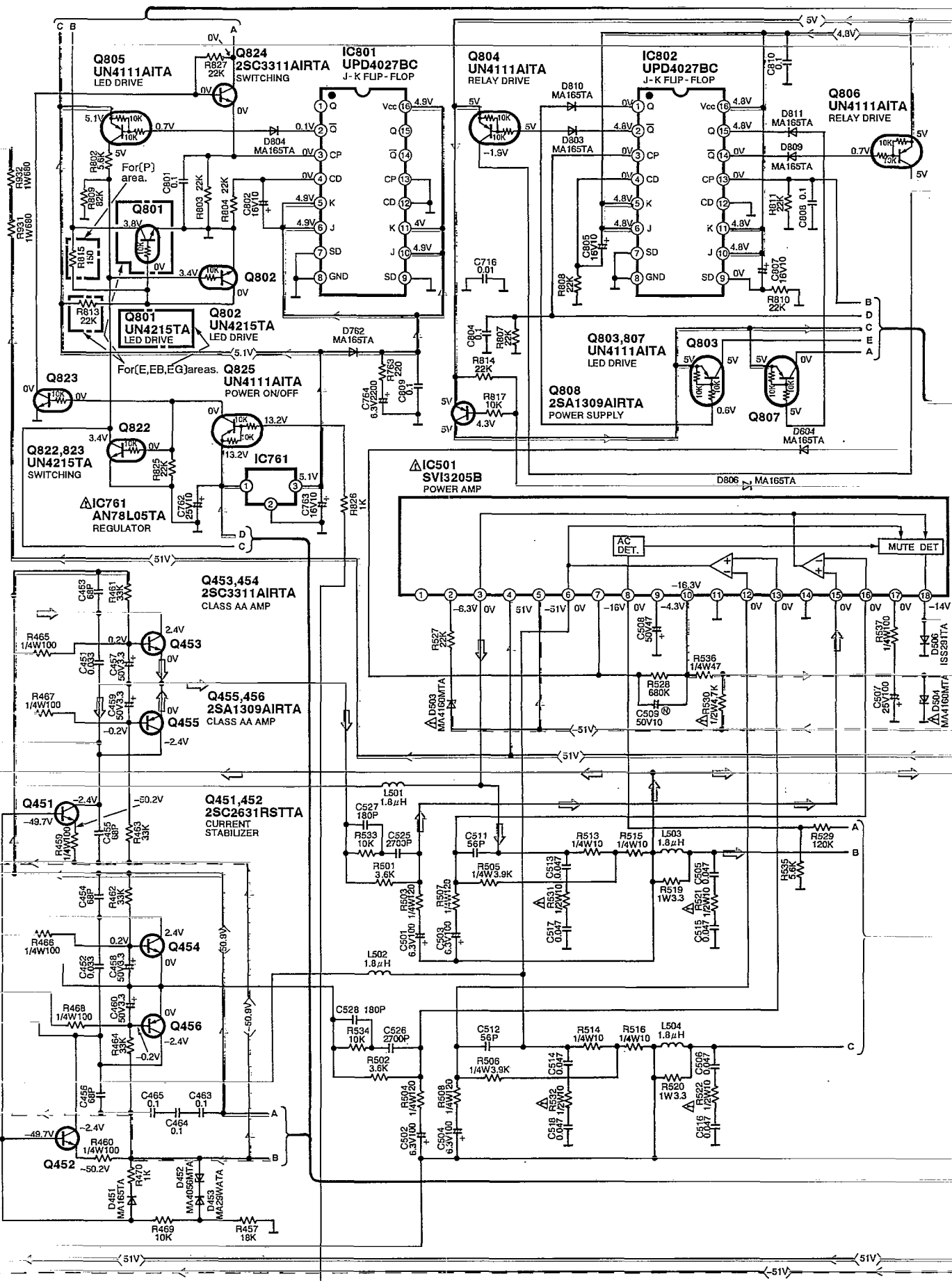

A MAIN CIRCUIT (P.C.Board.on pages 18,19)

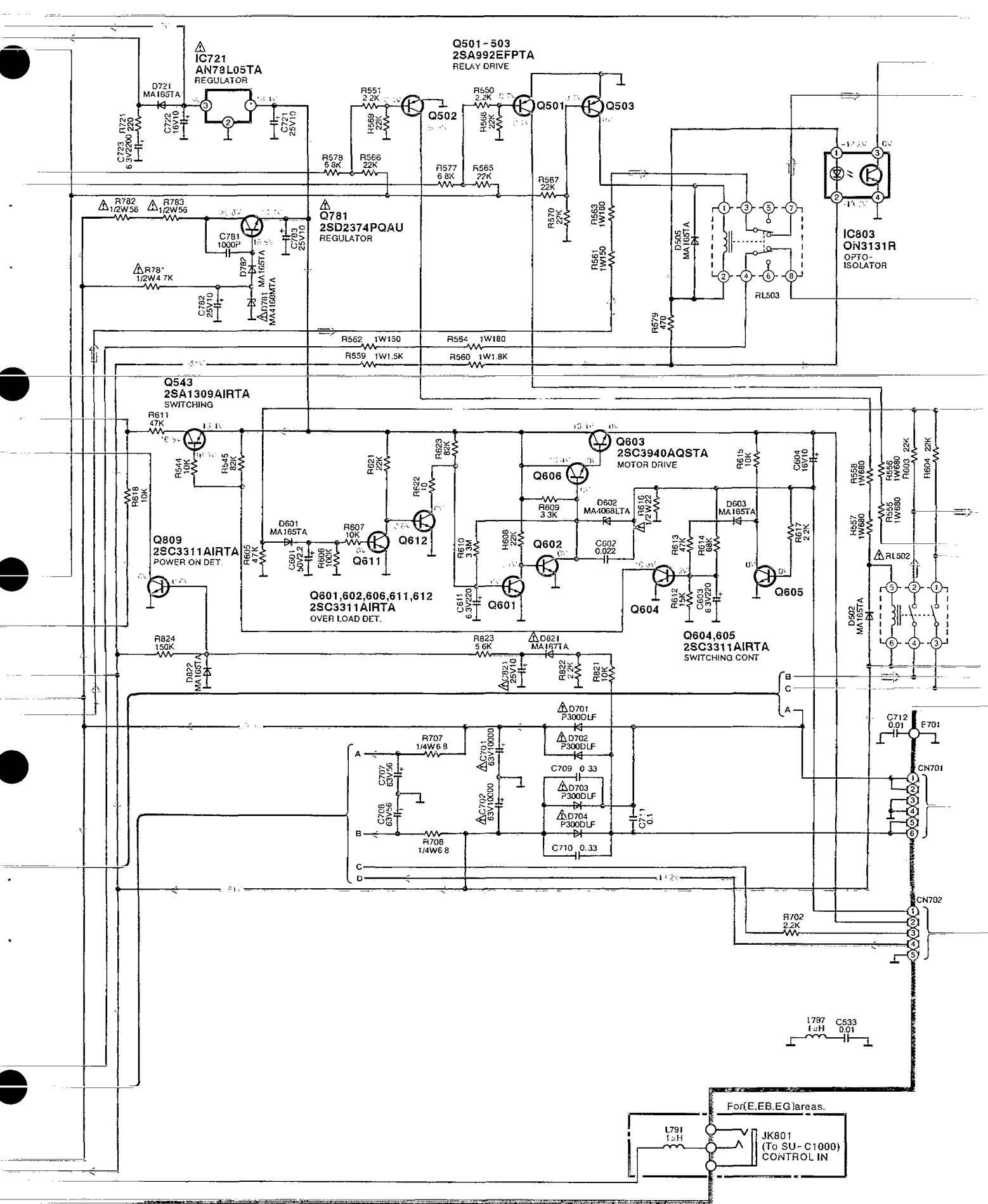

B SP. SWITCH CIRCUIT
(P.C.Board: on pages 18,19)

D POWER SWITCH CIRCUIT
(P.C.Board: on page 19)

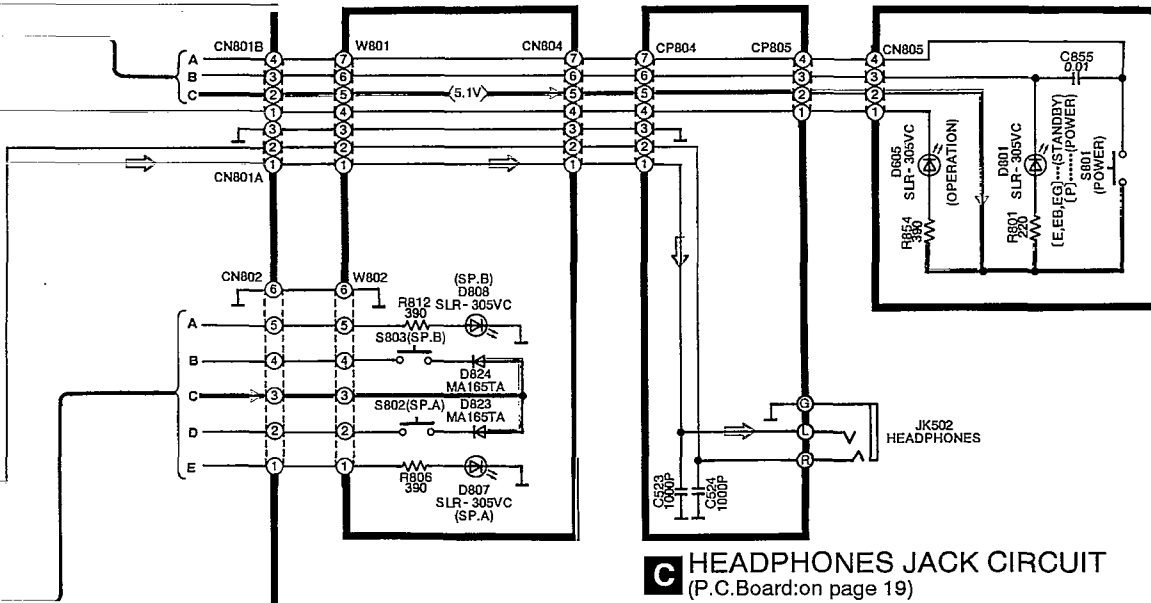

C HEADPHONES JACK CIRCUIT
(P.C.Board: on page 19)

E LAMP (RIGHT) CIRCUIT (P.C.Board: on page 17)

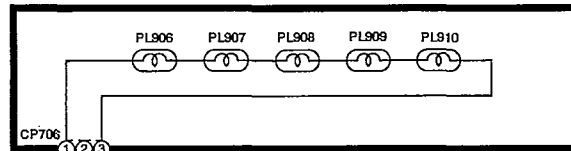

F LAMP (LEFT) CIRCUIT (P.C.Board: on page 17)

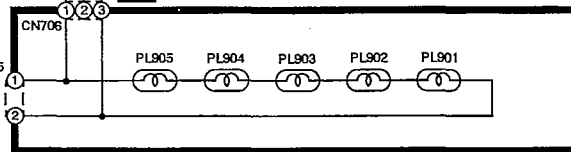

H POWER SUPPLY CIRCUIT
(P.C.Board: on pages 20,21)

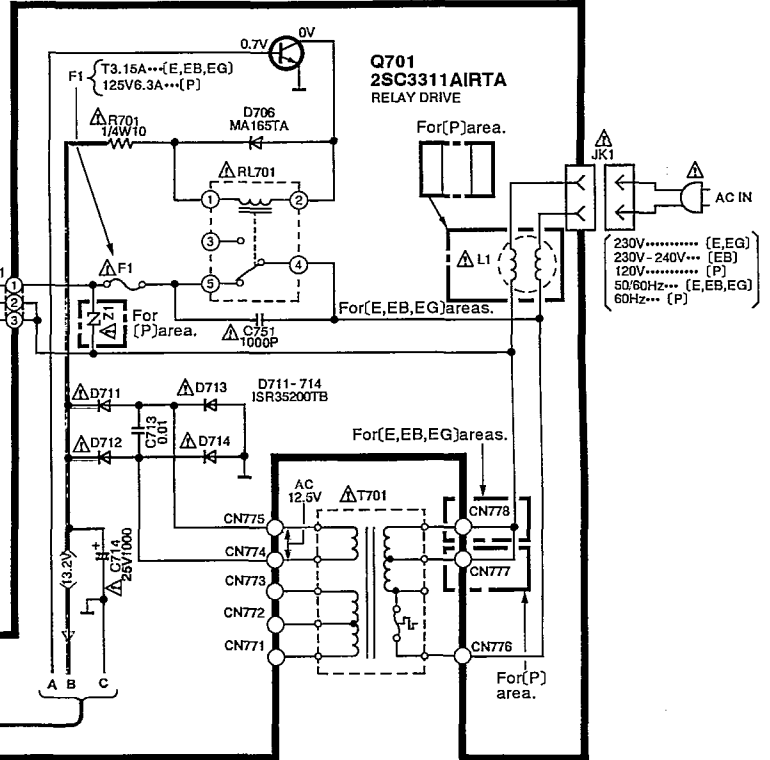

G POWER TRANSFORMER CIRCUIT
(P.C.Board: on pages 20,21)

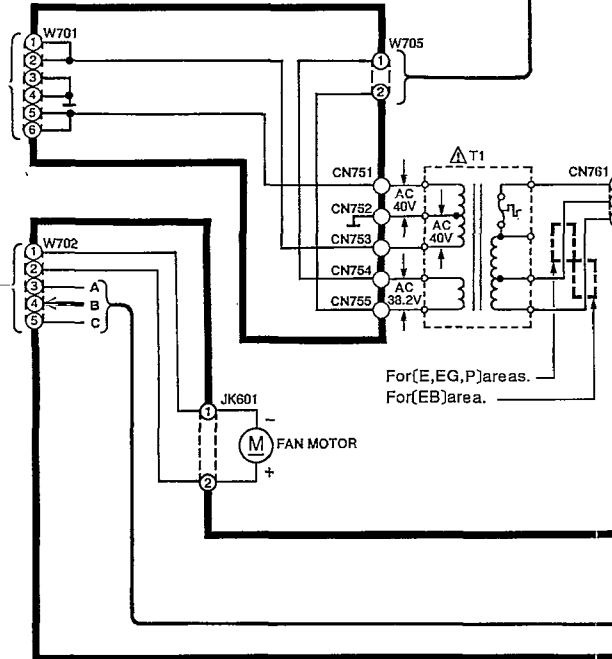

→ : Positive Voltage Line ←←←←← : Negative Voltage Line → : Source Signal Line

Printed Circuit Board Diagram

• This circuit board diagram may be modified at any time with the development of new technology.

E LAMP (RIGHT) P.C.B. (REP2154A-2S)

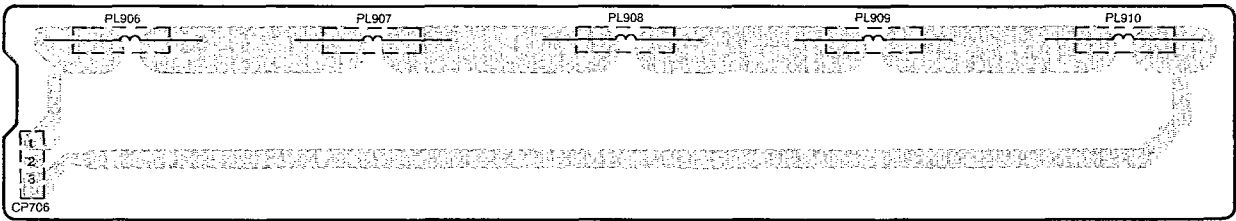

F LAMP (LEFT) P.C.B. (REP2154A-2S)

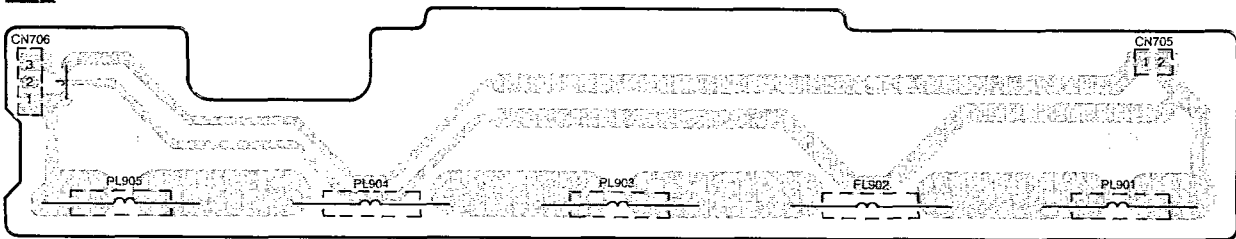

<p>M5218AP</p>	<p>UPD4027BC</p>	<p>AN7062N</p>	<p>ON3131R</p>	<p>BA6138</p>	<p>AN78L05TA</p>
<p>RSN6000A SVI3205B</p>	<p>2SA992EFPTA 2SA1123RSTTA 2SC2631RSTTA</p> <p>E C B</p>	<p>2SC3940AQSTA</p> <p>E C B</p>	<p>2SD2374PQAU</p> <p>B C E</p>	<p>2SJ105GRYTA 2SK330GRYTA</p> <p>D G S</p>	
<p>2SA1309AIRTA 2SC3311AIRTA UN4111 UN4215</p> <p>E C B</p>	<p>Ca Cathode Anode</p> <p>MA165 MA167 MA29WA</p>	<p>Ca Cathode Anode</p> <p>1SS291TA</p>	<p>Ca Cathode Anode</p> <p>1SR35200TB</p>		
<p>P300DLF</p> <p>Ca Cathode Anode</p>	<p>MA4036MTA MA4056MTA MA4068L</p> <p>Ca Cathode Anode</p>	<p>Ca Cathode Anode</p> <p>MA4100MTA MA4160M MA4220MTA</p>	<p>Anode Cathode Ca</p> <p>SLR-305VC</p>		

A MAIN P.C.B.

(REP2153C-M...[E,EG]
REP2153F-M...[EB]
REP2153G-M...[P])

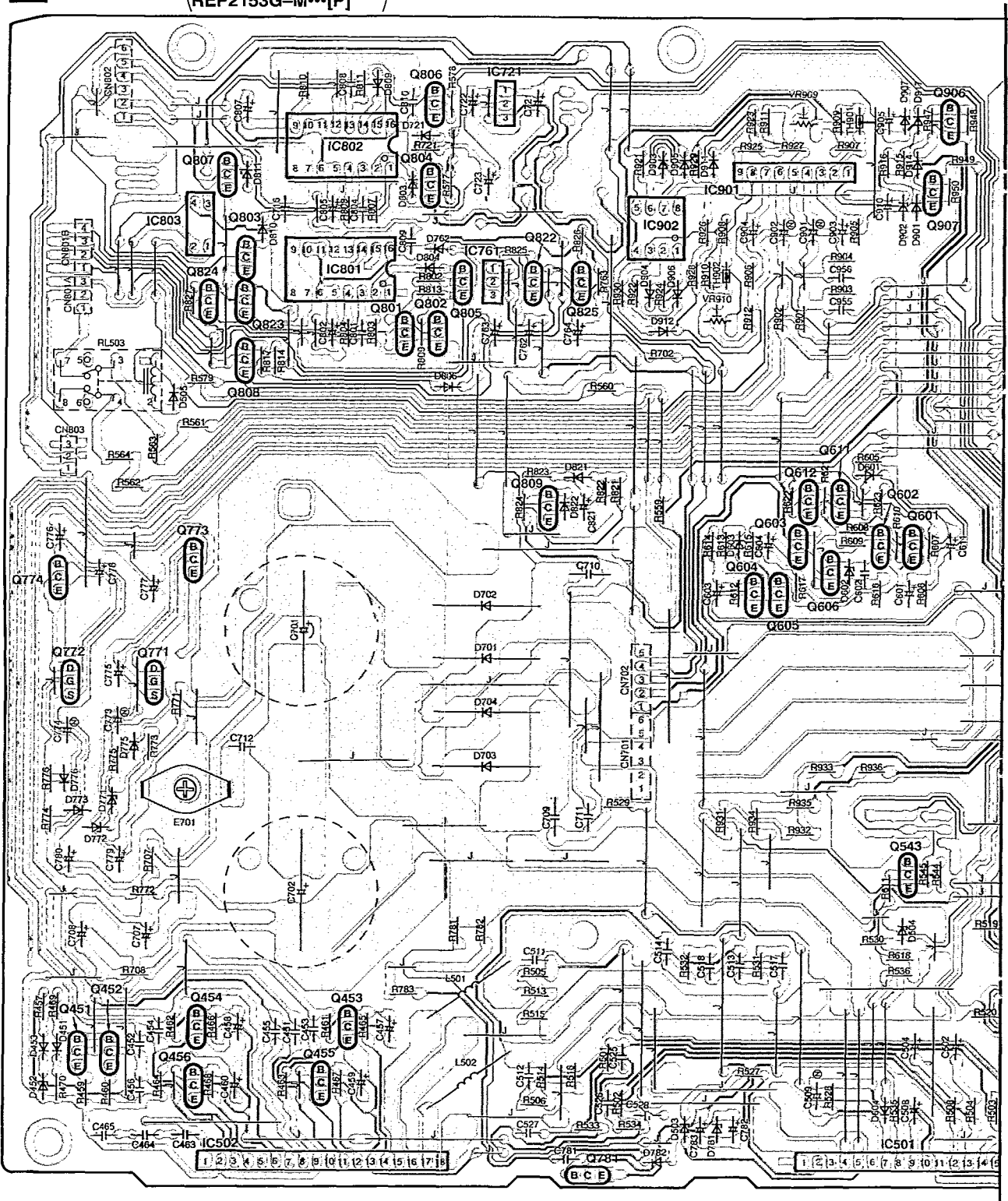

B SP. SWITCH P.C.B. (REP2154A-2S)

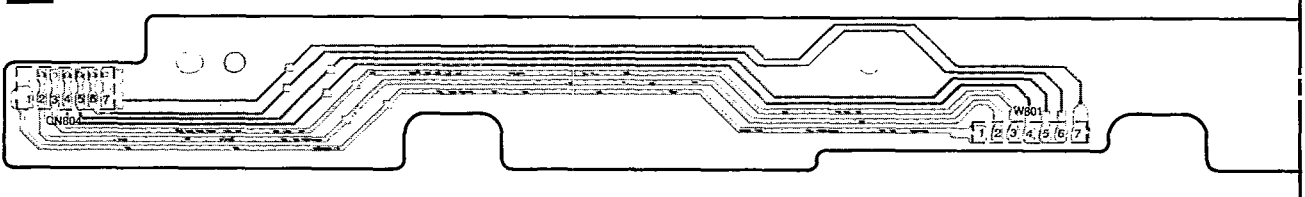

G POWER TRANSFORMER P.C.B. (REP2154F-1S)
For [P] area.

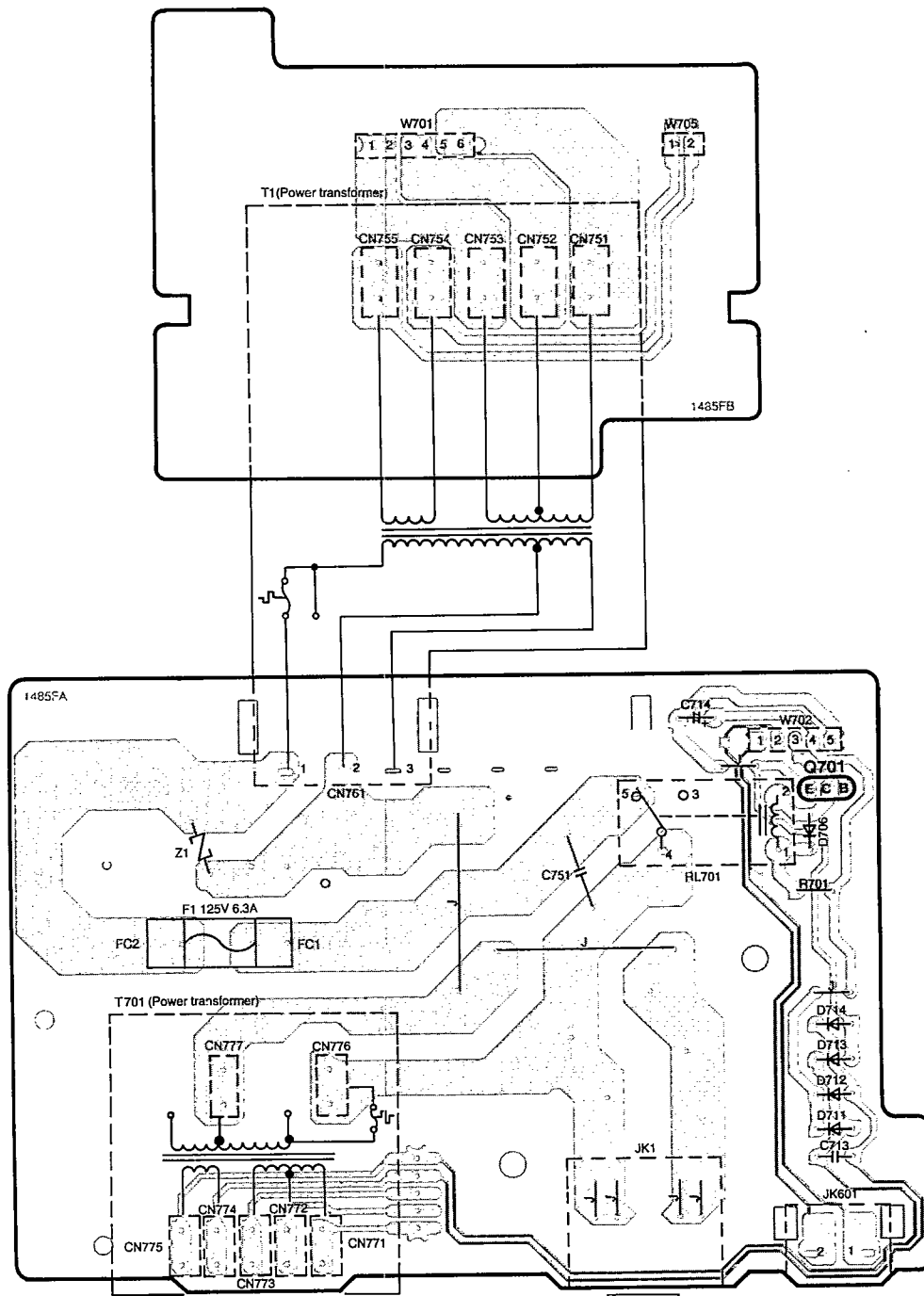

H POWER SUPPLY P.C.B. (REP2154F-1S)
For [P] area.

AC IN
(120V 60Hz)

E POWER TRANSFORMER P.C.B. (REP2154G-1S...[E,EG])
 For [E,EB,EG] areas. (REP2154H-1S...[EB])

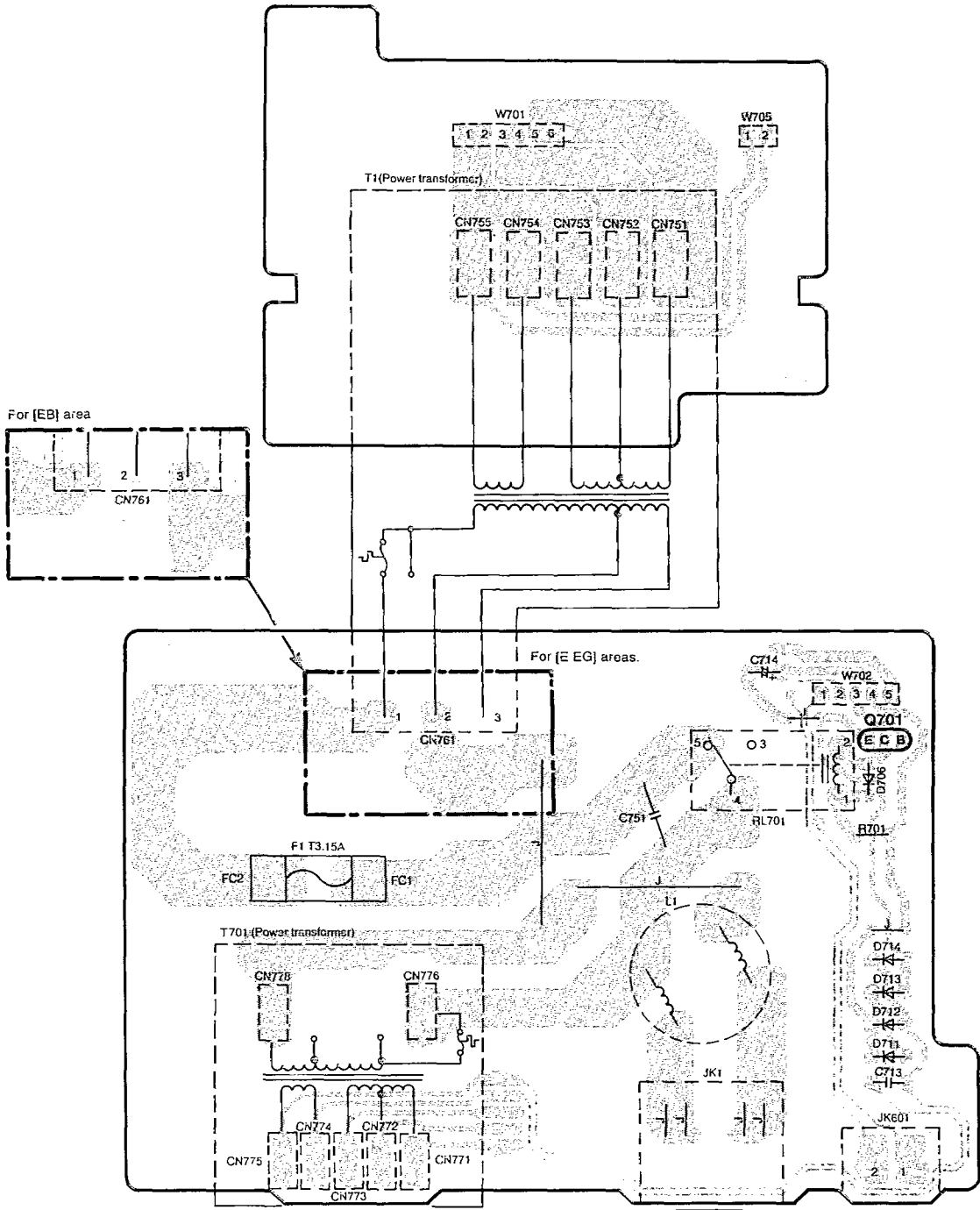

E POWER SUPPLY P.C.B.
 For [E,EB,EG] areas.
 (REP2154G-1S...[E,EG])
 (REP2154H-1S...[EB])

AC IN
 (230V [E,EG])
 (230V-240V . . [EB])
 50/60Hz

Wiring Connection Diagram

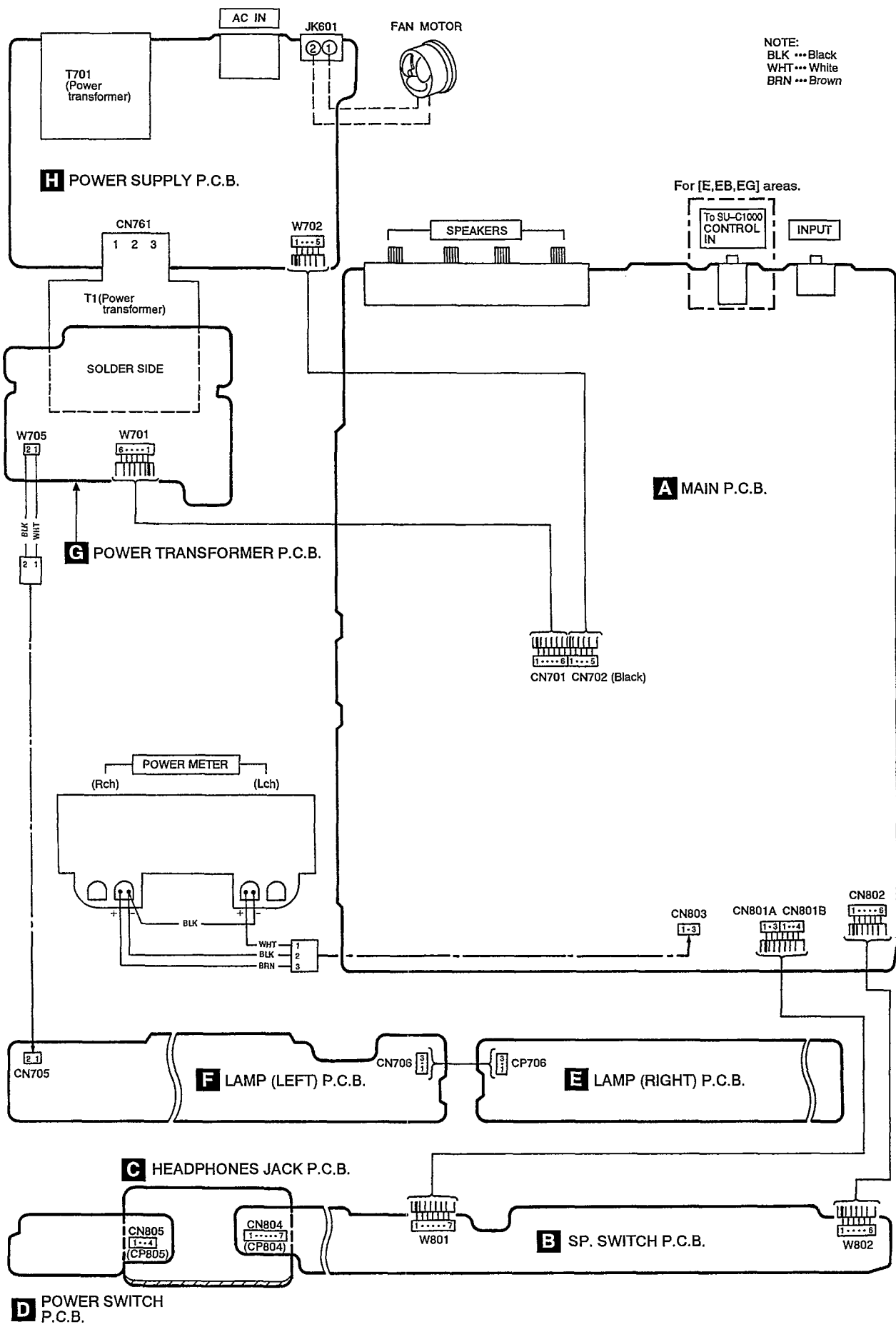

NOTE:
 BLK ... Black
 WHT ... White
 BRN ... Brown

For [E,EB,EG] areas.

CN701 CN702 (Black)

Block Diagram

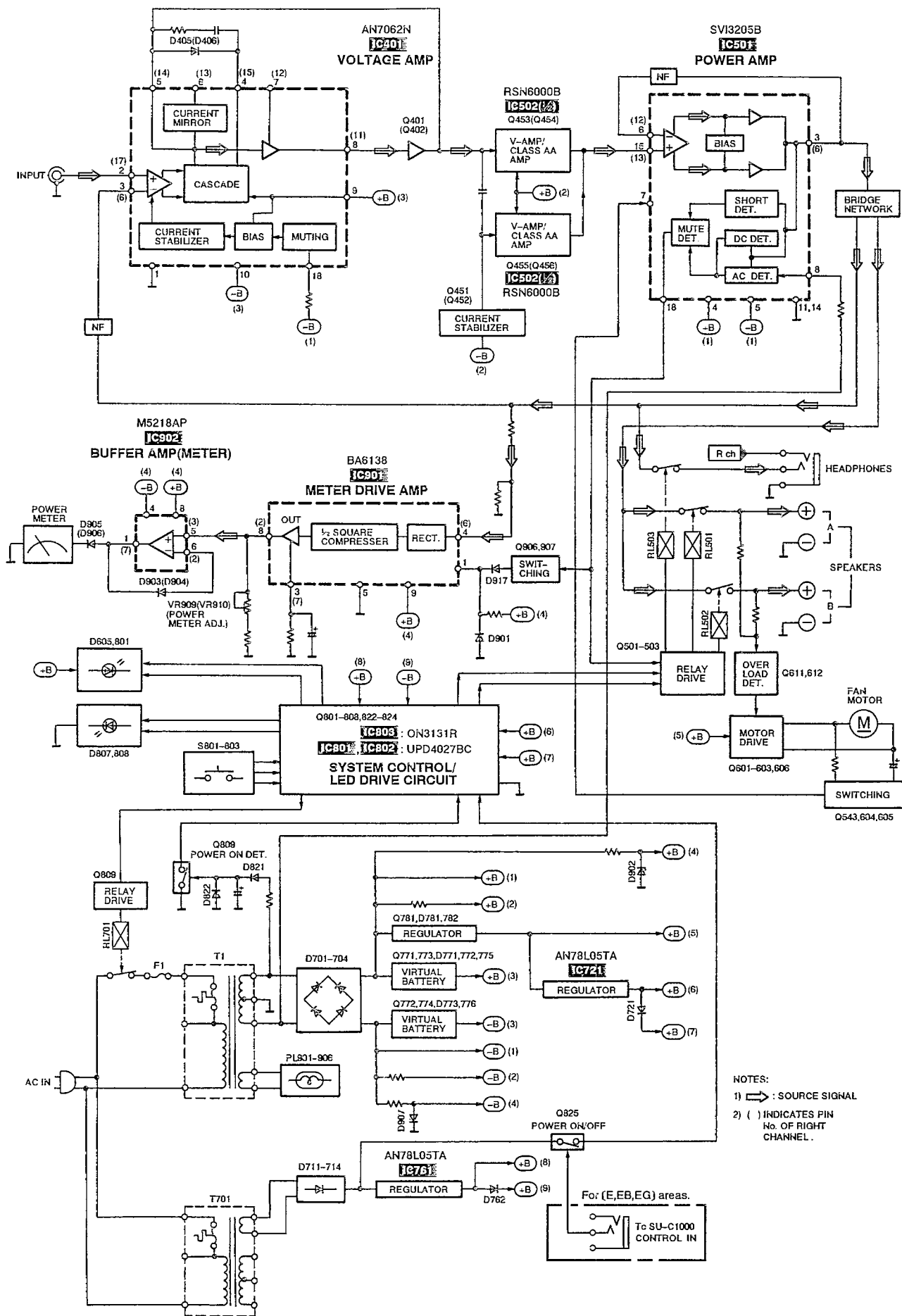

Replacement Parts List

Notes: *Important safety notices:

 Components identified by Δ mark have special characteristics important for safety.

Furthermore, special parts which have purposes of fire-retardant (resistors), high-quality sound (capacitors), low-noise (resistors), etc. are used.

When replacing any of components, be sure to use only manufacture's specified parts shown in the parts list.

*The parenthesized indications in the Remarks columns specify the areas. (Refer to the cover page for area.)

Parts without these indications can be used for all areas.

*The "(SF)" mark denotes the standard part.

*-<VRD>: indicates parts that are supplied by Video Recorder Division.

Ref. No.	Part No.	Part Name & Description	Remarks	Ref. No.	Part No.	Part Name & Description	Remarks
		INTEGRATED CIRCUIT(S)		D405, 406	MA165	DIODE	
				D451	MA165	DIODE	
IC401	AN7062N	IC, VOLTAGE AMP.		D452	MA4056MTA	DIODE	
IC501	SVI3205B	IC, POWER AMP.	Δ	D453	MA29WA	DIODE	
IC502	RSN6000A	IC, V-AMP.		D501, 502	MA165	DIODE	
IC721	AN78L05TA	IC, REGULATOR	Δ	D503, 504	MA4160M	DIODE	Δ
IC761	AN78L05TA	IC, REGULATOR	Δ	D505	MA165	DIODE	
IC801, 802	UPD4027BC	IC, J-K FLIP-FLOP		D506	1SS291TA	DIODE	
IC803	ON3131R	IC, OPTO-ISOLATOR		D601	MA165	DIODE	
IC901	BA6138	IC, METER DRIVE AMP.		D602	MA4068L	DIODE	
IC902	M5218AP	IC, BUFFER AMP.		D603, 604	MA165	DIODE	
		TRANSISTOR(S)		D605	SLR-305VC	LED	
				D701-704	P300DLF	DIODE	Δ
Q401, 402	2SA1123RSTTA	TRANSISTOR		D706	MA165	DIODE	
Q451, 452	2SC2631RSTTA	TRANSISTOR		D711-714	1SR35200TB	DIODE	Δ
Q453, 454	2SC3311AIRTA	TRANSISTOR		D721	MA165	DIODE	
Q455, 456	2SA1309AIRTA	TRANSISTOR		D762	MA165	DIODE	
Q501-503	2SA992EFPPTA	TRANSISTOR		D771, 772	MA4220MTA	DIODE	Δ
Q543	2SA1309AIRTA	TRANSISTOR		D773	MA4160M	DIODE	Δ
Q601, 602	2SC3311AIRTA	TRANSISTOR		D775, 776	MA165	DIODE	
Q603	2SC3940AQSTA	TRANSISTOR		D781	MA4160M	DIODE	Δ
Q604-606	2SC3311AIRTA	TRANSISTOR		D782	MA165	DIODE	
Q611, 612	2SC3311AIRTA	TRANSISTOR		D801	SLR-305VC	LED	
Q701	2SC3311AIRTA	TRANSISTOR		D803, 804	MA165	DIODE	
Q771	2SK330GRYTA	TRANSISTOR	Δ	D806	MA165	DIODE	
Q772	2SJ105GRYTA	TRANSISTOR	Δ	D807, 808	SLR-305VC	LED	
Q773	2SC2631RSTTA	TRANSISTOR	Δ	D809-811	MA165	DIODE	
Q774	2SA1123RSTTA	TRANSISTOR	Δ	D821	MA167	DIODE	Δ
Q781	2SD2374PQAU	TRANSISTOR	Δ	D822-824	MA165	DIODE	
Q801	UN4215	TRANSISTOR	(E, EB, EG)	D901	MA165	DIODE	
Q802	UN4215	TRANSISTOR		D902	MA4100MTA	DIODE	Δ
Q803-807	UN4111	TRANSISTOR		D903-906	MA165	DIODE	
Q808	2SA1309AIRTA	TRANSISTOR		D907	MA4100MTA	DIODE	Δ
Q809	2SC3311AIRTA	TRANSISTOR		D911, 912	MA165	DIODE	
Q822, 823	UN4215	TRANSISTOR		D914	MA165	DIODE	
Q824	2SC3311AIRTA	TRANSISTOR		D917	MA165	DIODE	
Q825	UN4111	TRANSISTOR				VARIABLE RESISTOR(S)	
Q906	2SC3311AIRTA	TRANSISTOR		VR909, 910	EVNDXAA00B23	V. R, POWER METER ADJ.	
Q907	2SA1309AIRTA	TRANSISTOR				THERMISTOR(S)	
		DIODE(S)		TH901, 902	ERTD2ZHL104T	THERMISTOR	
D401, 402	MA167	DIODE				COIL(S)	
D403, 404	MA4036MTA	DIODE					

Ref. No.	Part No.	Part Name & Description	Remarks	Ref. No.	Part No.	Part Name & Description	Remarks
L1	SLQZ650MH49	COIL	△ (E, EB, EG)	E401	SNE1004-2	GND PLATE	
L401, 402	ELEXT100KA9	COIL		E701	SNE1004-2	GND PLATE	
L403	BL02RN1R62T2	COIL				FUSE HOLDER	
L501-504	SLQY18G-10	COIL					
L791	ELEXT1R0KA9	COIL	(E, EB, EG)	FC1, 2	EYF52BC	FUSE HOLDER	
L797	ELEXT1R0KA9	COIL				RELAY(S)	
		TRANSFORMER(S)		RL501, 502	RSY0013M-0	RELAY	△
T1	RTP1P5B005-W	POWER TRANSFORMER	△ (E, EB, EG)	RL503	RSY0020M-R	RELAY	
T1	RTP1P5P001-W	POWER TRANSFORMER	△ (P)	RL701	RSY0019M-0	RELAY	△
T701	RTP1J5B001-W	POWER TRANSFORMER	△			JACK(S)	
		LAMP(S)		JK1	SJS9236	AC INLET	△ (E, EB, EG)
PL901-910	XAMR131	LAMP		JK1	SJSD16	AC INLET	△ (P)
		FUSE(S)		JK401	SJF3068A	JACK INPUT	
F1	XBA2C31T80	FUSE, 250V, 3. 15A	△ (E, EB, EG)	JK501	RJH4801M-1	SPEAKER TERMINAL	(E, EG, P)
F1	XBA1C63NBAU	FUSE, 125V, 6. 3A	△ (P)	JK501	RJH4801M-2	SPEAKER TERMINAL	(EB)
		SWITCH(ES)		JK502	RJJ63TA01	HEADPHONE JACK	
S801	EVQ21405R	SW, POWER		JK601	RJS1A7402-1	CONNECTOR, FAN MOTOR	
S802	EVQ21405R	SW, SPEAKER A		JK801	RJJ33T01	JACK CONTROL IN	(E, EB, EG)
S803	EVQ21405R	SW, SPEAKER B				COMPONENT COMBINATION(S)	
		CONNECTOR(S)		Z1	ERZV10V511CS	SURGE ABORBER	△ (P)
CN701	RJS1A6606	CONNECTOR (6P)					
CN702	RJS1A6605	CONNECTOR (5P)					
CN705	RJP2G17ZA	CONNECTOR (2P)					
CN706	SJS50382JQH	SOCKET (3P)					
CN751-755	RJS1A1101T1	CONNECTOR (1P)					
CN761	SJS305-1	CONNECTOR (3P)					
CN771-776	RJS1A1101T1	CONNECTOR (1P)					
CN777	RJS1A1101T1	CONNECTOR (1P)	(P)				
CN778	RJS1A1101T1	CONNECTOR (1P)	(E, EB, EG)				
CN802	RJS1A6606	CONNECTOR (6P)					
CN803	RJP3G18ZA	CONNECTOR (3P)					
CN804	RJU057W007	SOCKET (7P)					
CN805	RJU057W004	SOCKET (4P)					
CN801A	RJS1A6603	SOCKET (3P)					
CN801B	RJS1A6604	CONNECTOR (4P)					
CP706	SJT30345JQ	CONNECTOR (3P)					
CP804	RJT057W007-1	CONNECTOR (7P)					
CP805	RJT057W004-1	CONNECTOR (4P)					
		EARTH TERMINAL					

Notes : * Capacity values are in microfarads (μF) unless specified otherwise, P=Pico-farads (pF) F=Farads (F)
 * Resistance values are in ohms, unless specified otherwise, 1K=1,000(OHM) , 1M=1,000k(OHM)

Ref. No.	Part No.	Values & Remarks	Ref. No.	Part No.	Values & Remarks	Ref. No.	Part No.	Values & Remarks
		RESISTORS	R609	ERDS2TJ332	1/4W 3.3K	R909, 910	ERDS2TJ103	1/4W 10K
R401, 402	ERDAS3G122	1/4W 1.2K	R610	ERDS2TJ335T	1/4W 3.3M	R911, 912	ERDS2TJ821	1/4W 820
R403, 404	ERDAS3G823T	1/4W 82K	R611	ERDS2TJ473	1/4W 47K	R915	ERDS2TJ103	1/4W 10K
R405, 406	ERDAS3G272T	1/4W 2.7K	R612	ERDS2TJ153	1/4W 15K	R916	ERDS2TJ104	1/4W 100K
R407, 408	ERDAS3G823T	1/4W 82K	R613	ERDS2TJ473	1/4W 47K	R921, 922	ERDS2TJ123	1/4W 12K
R411, 412	ERDAF2VJ470T	1/4W 47	R614	ERDS2TJ683	1/4W 68K	R923, 924	ERDS2TJ154	1/4W 150K
R437	ERDS2TJ473	1/4W 47K	R615	ERDS2TJ103	1/4W 10K	R925, 926	ERDS2TJ223	1/4W 22K
R457	ERDAS3G183T	1/4W 18K	R616 Δ	ERDS1FVJ220T	1/2W 22	R927, 928	ERDS2TJ102	1/4W 1K
R459, 460	ERDAF2VJ101T	1/4W 100	R617	ERDS2TJ222	1/4W 2.2K	R929, 930	ERDS2EJ121	1/4W 120
R461-464	ERDS2TJ333	1/4W 33K	R618	ERDS2TJ103	1/4W 10K	R931-936	ERG1SJ681E	1W 680
R465-468	ERDAF2VJ101T	1/4W 100	R621	ERDS2TJ223	1/4W 22K	R947, 948	ERDS2TJ103	1/4W 10K
R469	ERDAS3G103T	1/4W 10K	R622	ERDS2TJ100	1/4W 10	R949, 950	ERDS2TJ223	1/4W 22K
R470	ERDAS3G102T	1/4W 1K	R623	ERDS2TJ823T	1/4W 82K			CAPACITORS
R471, 472	ERDS2TJ561	1/4W 560	R701 Δ	ERD25FVJ100T	1/4W 10	C401, 402	ECA1HPXS4R7B	50V 4.7U
R491, 492	ERDAS3G823T	1/4W 82K	R702	ERDS2TJ222	1/4W 2.2K	C403, 404	ECKD1H471KB	50V 470P
R501, 502	ERDS2TJ362T	1/4W 3.6K	R707, 708	ERDAF2VJ6R8T	1/4W 6.8	C405, 406	ECA1EPX101TB	25V 100
R503, 504	ERDAF2VJ121T	1/4W 120	R721	ERDS2TJ221	1/4W 220	C407, 408	ECBT1H820KB5	50V 82P
R505, 506	ERDAF2VJ392T	1/4W 3.9K	R763	ERDS2TJ221	1/4W 220	C409, 410	ECCR2H220J5	500V 22P
R507, 508	ERDAF2VJ121T	1/4W 120	R771	ERDAF2VJ470T	1/4W 47	C413, 414	ECCV2H070D	500V 7P
R513-516	ERDAF2VJ100T	1/4W 10	R772	ERDAF2VJ121T	1/4W 120	C415, 416	ECBT1H102KB5	50V 1000P
R519, 520	ERX1SJ3R3E	1W 3.3	R773	ERDS2TJ332	1/4W 3.3K	C426	ECBT1H102KB5	50V 1000P
R521, 522 Δ	ERDS1FVJ100T	1/2W 10	R774	ERDS2TJ103	1/4W 10K	C427	ECBT1E223ZF	25V 0.022U
R527	ERDS2TJ223	1/4W 22K	R775, 776	ERDS2TJ105T	1/4W 1M	C428	ECQV1H473JM3	50V 0.047U
R528	ERDS2TJ684	1/4W 680K	R781 Δ	ERDS1FVJ472T	1/2W 4.7K	C451, 452	ECKR1H333ZF5	50V 0.033U
R529	ERDS2TJ124T	1/4W 120K	R782, 783 Δ	ERDS1FVJ560T	1/2W 56	C453-456	ECCV2H680K	500V 68P
R530 Δ	ERDS1FVJ472T	1/2W 4.7K	R801	ERDS2TJ221	1/4W 220	C457-460	RCE1HKA3R3BG	50V 3.3U
R531, 532 Δ	ERDS1FVJ100T	1/2W 10	R802	ERDS2TJ562	1/4W 5.6K	C461, 462	ECBT1H102KB5	50V 1000P
R533, 534	ERDS2TJ103	1/4W 10K	R803, 804	ERDS2TJ223	1/4W 22K	C463-465	ECBT1H104ZF5	50V 0.1U
R535	ERDS2TJ562	1/4W 5.6K	R806	ERDS2TJ391	1/4W 390	C491, 492	ECBT1H101KB5	50V 100P
R536	ERDAF2VJ470T	1/4W 47	R807, 808	ERDS2TJ223	1/4W 22K	C501-504	ECA0JPXS101B	6.3V 100U
R537	ERDAF2VJ101T	1/4W 100	R809	ERDS2TJ823T	1/4W 82K	C505, 506	ECQV1H473JM3	50V 0.047U
R544	ERDS2TJ103	1/4W 10K	R810, 811	ERDS2TJ223	1/4W 22K	C507	ECA1EM101B	25V 100U
R545	ERDS2TJ823T	1/4W 82K	R812	ERDS2TJ391	1/4W 390	C508	ECA1HM470B	50V 47U
R550, 551	ERDS2TJ222	1/4W 2.2K	R813	ERDS2TJ223	1/4W 22K (E, EB, EG)	C509	ECEA1HN100SB	50V 10U
R555-558	ERG1SJ681E	1W 680	R814	ERDS2TJ223	1/4W 22K	C511, 512	ECBT1H560J5	50V 56P
R559	ERG1SJ152E	1W 1.5K	R815	ERDS2TJ151	1/4W 150 (P)	C513-518	ECQV1H473JM3	50V 0.047U
R560	ERG1SJ182E	1W 1.8K	R817	ERDS2TJ103	1/4W 10K	C519-522	ECQB1H223JF3	50V 0.022U
R561, 562	ERG1SJ151E	1W 150	R821	ERDS2TJ103	1/4W 10K	C523, 524	ECBT1H102KB5	50V 1000P
R563, 564	ERG1SJ181E	1W 180	R822	ERDS2TJ222	1/4W 2.2K	C525, 526	ECBT1C272KR5	16V 2700P
R565-570	ERDS2TJ223	1/4W 22K	R823	ERDS2TJ562	1/4W 5.6K	C527, 528	ECBT1H181KB5	50V 180P
R577, 578	ERDS2TJ682T	1/4W 6.8K	R824	ERDS2TJ154	1/4W 150K	C533	ECBT1C103NS5	16V 0.01U
R579	ERDS2TJ471	1/4W 470	R825	ERDS2TJ223	1/4W 22K	C601	ECEA1HKA2R2B	50V 2.2U
R601-604	ERDS2TJ223	1/4W 22K	R826	ERDS2TJ102	1/4W 1K	C602	ECBT1E223ZF	25V 0.022U
R605	ERDS2TJ473	1/4W 47K	R827	ERDS2TJ223	1/4W 22K	C603	RCE0JKA221BV	6.3V 220U
R606	ERDS2TJ104	1/4W 100K	R854	ERDS2TJ391	1/4W 390	C604	RCE1CKA100BG	16V 10U
R607	ERDS2TJ103	1/4W 10K	R901, 902 Δ	ERDS1FVJ472T	1/2W 4.7K	C611	RCE0JKA221BV	6.3V 220U
R608	ERDS2TJ223	1/4W 22K	R903, 904	ERDAF2VJ271T	1/4W 270	C701, 702 Δ	ECETX1J103XM	63V 10000U
			R905, 906	ERDS2TJ155	1/4W 1.5M			
			R907, 908	ERDS2TJ682T	1/4W 6.8K			

Ref. No.	Part No.	Values & Remarks							
C707, 708	ECA1JPXH560B	63V 56U							
C709, 710	ECQE2334KFW	250V 0.33U							
C711	ECQE2104KF3	250V 0.1U							
C712	ECBT1C103NS5	16V 0.01U							
C713	ECKR1H103ZF5	50V 0.01U							
C714 Δ	ECA1EM102E	25V 1000U							
C716	ECBT1C103NS5	16V 0.01U							
C721	ECEA1EKA100B	25V 10U							
C722	RCE1CKA100BG	16V 10U							
C723	ECA0JM222B	6.3V 2200U							
C751 Δ	ECKWNS102MBM	500V 1000P							
C762	ECEA1EKA100B	25V 10U							
C763	RCE1CKA100BG	16V 10U							
C764	ECA0JM222B	6.3V 2200U							
C773, 774	ECEA1HBZ4R7B	50V 4.7U							
C775	ECA1HPXS470B	50V 47U							
C776	ECA1EPX101TB	25V 100U							
C777	ECA1JPX470TB	63V 47U							
C778	ECA1EPX470TB	25V 47U							
C779, 780	ECA2APXS100B	100V 10U							
C781	ECBT1H102KB5	50V 1000P							
C782, 783	ECEA1EKA100B	25V 10U							
C801	ECBT1H104ZF5	50V 0.1U							
C802	RCE1CKA100BG	16V 10U							
C804	ECBT1H104ZF5	50V 0.1U							
C805	RCE1CKA100BG	16V 10U							
C807	RCE1CKA100BG	16V 10U							
C808-810	ECBT1H104ZF5	50V 0.1U							
C821 Δ	ECEA1EKA100B	25V 10U							
C855	ECBT1C103NS5	16V 0.01U							
C901, 902	ECEA1EKN3R3B	25V 3.3U							
C903, 904	ECEA1HKA2R2B	50V 2.2U							
C905	RCE1HKA4R7BG	50V 4.7U							
C910	RCE1HKA4R7BG	50V 4.7U							
C955, 956	ECBT1C152JR5	16V 1500P							

Cabinet Parts Location

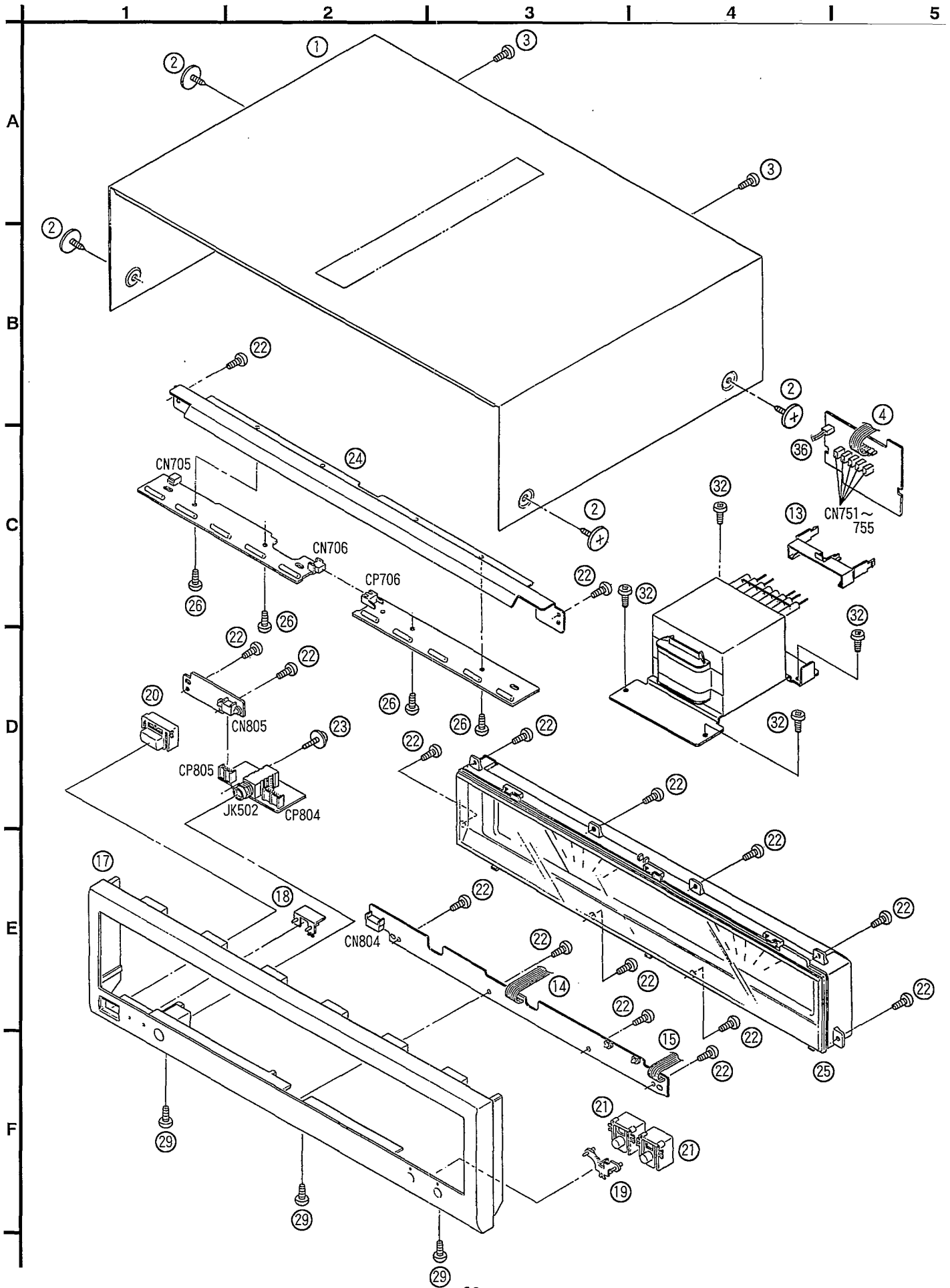

6 | 7 | 8 | 9 | 10

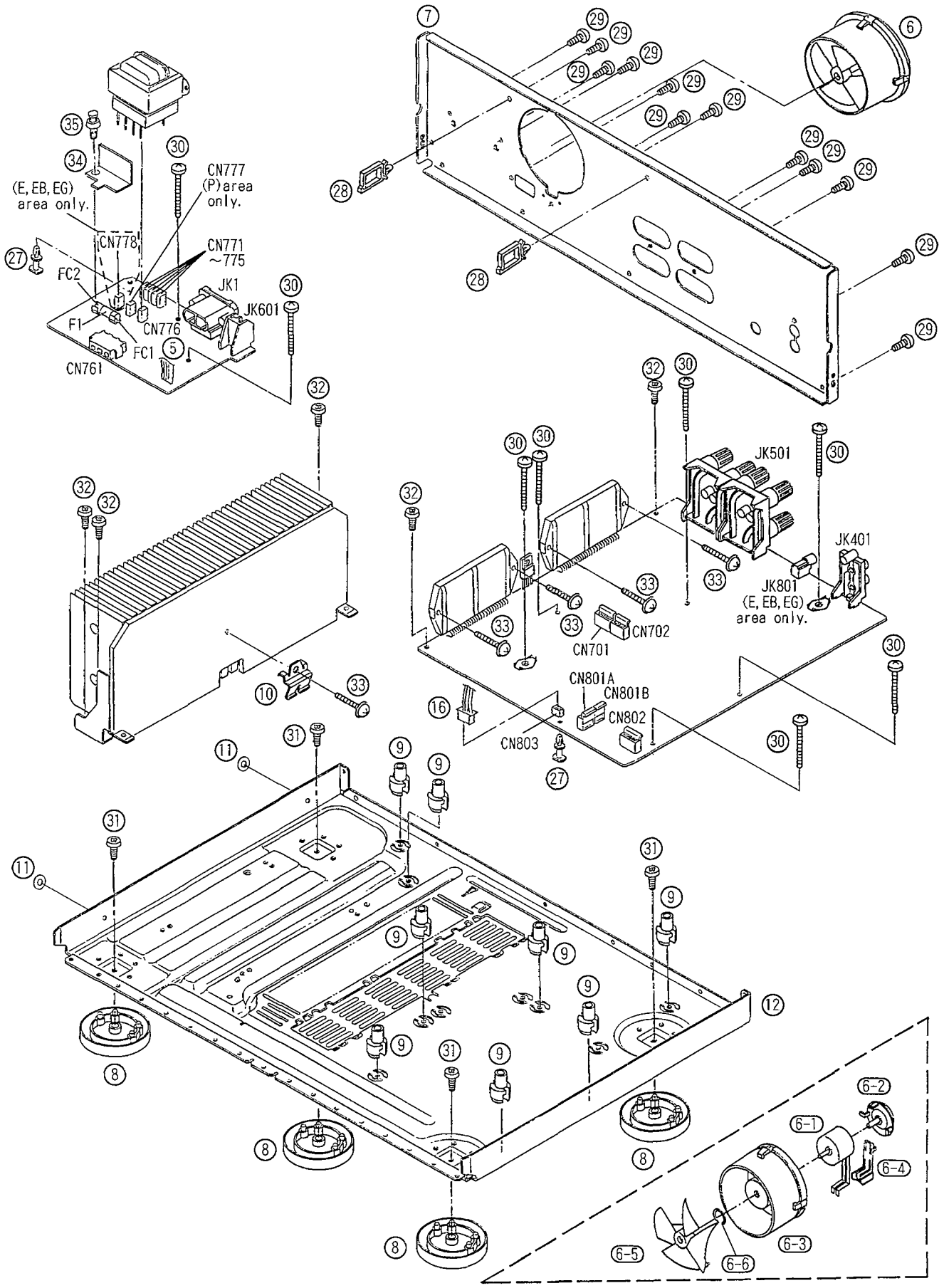

Note: The reference number SA represent the grease and tool used for this unit.

1062

Ref. No.	Part No.	Part Name & Description	Remarks
		CABINET PARTS LIST	
1	RKMO219F-K	TOP CABINET	
2	SNE2129-1	SCREW	
3	XTBS3+8JFZ1	SCREW	
4	RWJ3906440QQ	FLAT CABLE (6P) (W701)	
5	RWJ1805480QQ	FLAT CABLE (5P) (W702)	
6	REMO020-1	FAN ASS'Y	
6-1	MDN-4RB4MRC	FAN MOTOR COVER	
6-2	RMQ0208-K	FAN MOTOR	
6-3	RMQ0209-K	FAN CASE	
6-4	RMQ0212-K	FAN TERMINAL	
6-5	SHE232-1	FAN	
6-6	SUS271	SPRING	
7	RGR0227D-A1	REAR PANEL	(E, EG)
7	RGR0227E-A1	REAR PANEL	(EB)
7	RGR0227F-A	REAR PANEL	(P)
8	RKAO053-A	FOOT	
9	RKQ0089	P. C. B. SUPPORT	
10	RMCO158	TRANSISTOR HOLDER	
11	RMGO332-K	RUBBER	
12	RMKO200-3	CHASSIS	
13	RMNO217	HOLDER	
14	RWJ1807220KX	FLAT CABLE (7P) (W801)	
15	RWJ1806090KX	FLAT CABLE (6P) (W802)	
16	REX0741	CABLE ASS'Y (3P)	
17	RFKGEA1000EK	FRONT PANEL ASS'Y	
17	RFKGEA1000PK	FRONT PANEL ASS'Y	(P)
18	RGLO301-Q	PANEL LIGHT A	
19	RGLO302-Q	PANEL LIGHT B	
20	RGU1270-K	BUTTON, POWER	
21	RGU1271-K	BUTTON, SPEAKER	
22	RHD26017	SCREW	
23	RHD26018	SCREW	
24	RMAD869	ANGLE	
25	RSE0006	METER ASS'Y	
26	XTBS26+8J	SCREW	
27	SHR8006	SPACER	
28	SHR9814	SPACER	
29	XTBS3+8JFZ1	SCREW	
30	XTB3+20JFZ	SCREW	
31	XTB3+6G	SCREW	
32	XTB3+8JFZ	SCREW	
33	XIW3+15T	SCREW	
34	RMZO354	COVER	
35	SHR9112	NYLON RIVET	
36	REX0740	CABLE ASS'Y (2P)	
		PACKING MATERIALS	
P1	RPC2630	PACKING CASE	(E, EG)

Ref. No.	Part No.	Part Name & Description	Remarks
P1	RPG2631	PACKING CASE	(EB)
P1	RPG2632	PACKING CASE	(P)
P2	RPN0752	PAD	
P3	RPQ0164	PAD	
P4	RPF0139	PROTECTION COVER	
P5	SPP730	PROTECTION COVER	
P6	RPH0032	MIRROR SHEET	(EB)
		ACCESSORIES	
A1	RQA0013	WARRANTY CARD	(E, EB, EG)
A1	RQA0114	WARRANTY CARD	(P)
A2	RQCB0169	SERVICE CENTER LIST	(E, EB, EG)
A2	RQCB0391	SERVICE CENTER LIST	(P)
A3	RQT3108-B	INSTRUCTION MANUAL	(EB)
A3	RQT3107-E	INSTRUCTION MANUAL	(EG)
A3	RFKSEA1000EK	INSTRUCTION MANUAL	(E)
A3	RQT3109-P	INSTRUCTION MANUAL	(P)
A4	RJA0019-2K	AC POWER SUPPLY CORD	△ (E, EG) (SF)
A4	VJA0733	AC POWER SUPPLY CORD	△ (EB) <VRD> (SF)
A4	SJA172	AC POWER SUPPLY CORD	△ (P) (SF)
		GREASE OR JIG/TOOL	
SA1	RFKX0002	COMPOUND GREASE	

■ Packaging

