

# Service Manual

Computer Drive New Class A  
Stereo DC Power Amplifier

Amplifier  
**SE-A5MK2**

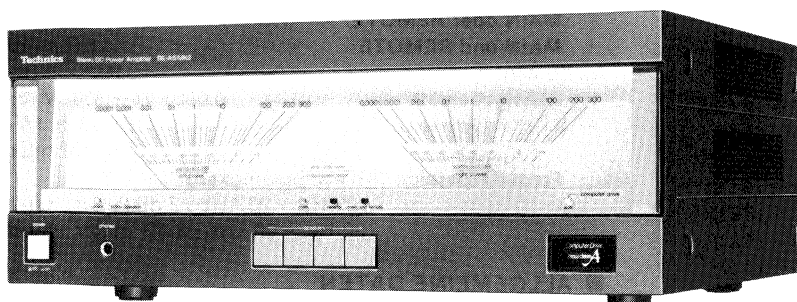

Please use this manual together with the service manual for  
Model No. SE-A5MK2 [M], Order No. HAD84032731C1.

## Color

(K) ... Black Type

Color	Areas
(K)	[D] . . . . . Scandinavia
(K)	[EW] . . . . . Switzerland
(K)	[EK] . . . . . United Kingdom
(K)	[EF] . . . . . France
(K)	[XA] . . . . . Southeast Asia, Oceania, Africa, Middle Near East and Central South America.
(K)	[PE] . . . . . European Military
(K)	[PA] . . . . . Far East PX
(K)	[XL] . . . . . Australia
(K)	[Ei] . . . . . Italy
(K)	[EH] . . . . . Holland
(K)	[EB] . . . . . Belgium
(K)	[PC] . . . . . European Audio Club
(K)	[EGA] . . . . . F.R. Germany

## SPECIFICATIONS

(DIN 45 500)

### ■ AMPLIFIER SECTION

20 Hz~20 kHz continuous power output both channels driven	2 × 150W (8Ω) 2 × 150W (4Ω)
40 Hz~16 kHz continuous power output both channels driven	2 × 150W (8Ω) 2 × 150W (4Ω)
1 kHz continuous power output both channels driven	2 × 150W (8Ω) 2 × 150W (4Ω)
<b>Total harmonic distortion</b>	
rated power at 20 Hz~20 kHz	0.002% (8Ω) 0.002% (4Ω)
rated power at 40 Hz~16 kHz	0.002% (8Ω) 0.002% (4Ω)
rated power at 1 kHz	0.002% (8Ω) 0.002% (4Ω)
half power at 20 Hz~20 kHz	0.001% (4Ω)
half power at 1 kHz	0.0005% (4Ω)
-26 dB power at 1 kHz	0.001% (4Ω)
50 mW power at 1 kHz	0.001% (4Ω)
<b>Intermodulation distortion</b>	
rated power at 250 Hz: 8 kHz=4:1, 4Ω	0.002%
rated power at 60 Hz: 7 kHz=4:1, SMPTE, 8Ω	0.002%
<b>TIM</b>	unmeasurably small
<b>Power bandwidth</b>	
both channels driven, -3 dB T.H.D. 0.01%	5 Hz~100 kHz (4Ω)

<b>Residual hum and noise</b>	0.13 mV
<b>Damping factor</b>	50 (4Ω), 100 (8Ω)
<b>Input sensitivity and impedance</b>	1 V/47kΩ
<b>S/N</b>	108 dB (121 dB, IHF, A)
<b>Frequency response</b>	DC ~20 kHz, +0 dB, -0.1 dB DC ~150 kHz, +0 dB, -3 dB
<b>Channel balance, 250 Hz~6,300 Hz</b>	±0.5 dB
<b>Channel separation, 1 kHz</b>	60 dB
<b>Headphones output level and impedance</b>	800 mV/330Ω
<b>Load impedance</b>	
<b>MAIN or REMOTE</b>	4Ω~16Ω
<b>MAIN and REMOTE</b>	8Ω~16Ω
<b>Meter</b>	
<b>reading range</b>	0.0001 W~300 W (8Ω) -60 dB~+5 dB (logarithmic compression)
<b>frequency response (reading accuracy)</b>	20 Hz~20 kHz ±2 dB (more than -50 dB) 20 Hz~20 kHz ±3 dB (less than -50 dB)

### ■ GENERAL

<b>Power consumption</b>	950W
<b>Power supply</b>	AC 50 Hz/60 Hz, 110V/120V/220V/240V
<b>Dimensions (W×H×D)</b>	430 × 178 × 416 mm
<b>Weight</b>	18.4 kg

#### Note:

Total harmonic distortion is measured by the digital spectrum analyzer (H.P. 3045 system).

Specifications are subject to change without notice for further improvement.

MC-Service

# Technics

Panasonic Tokyo  
Matsushita Electric Industrial Co., Ltd.  
1-2, 1-chome, Shibakoen, Minato-ku, Tokyo 105 Japan

Matsushita Electric Trading Co., Ltd.  
P.O. Box 288, Central Osaka Japan

## TECHNISCHE DATEN

(DIN 45 500)

### VERSTÄRKERTEIL

<b>Dauerton-Ausgangsleistung bei 20 Hz ~ 20 kHz</b>	
beide Kanäle ausgesteuert	2 × 150W (8 Ω) 2 × 150W (4 Ω)
<b>Dauerton-Ausgangsleistung bei 40 Hz ~ 16 kHz</b>	
beide Kanäle ausgesteuert	2 × 150W (8 Ω) 2 × 150W (4 Ω)
<b>Dauerton-Ausgangsleistung bei 1 kHz</b>	
beide Kanäle ausgesteuert	2 × 150W (8 Ω) 2 × 150W (4 Ω)
<b>Gesamtklirrfaktor</b>	
<b>Nennleistung bei 20 Hz ~ 20 kHz</b>	0,002% (8 Ω) 0,002% (4 Ω)
<b>Nennleistung bei 40 Hz ~ 16 kHz</b>	0,002% (8 Ω) 0,002% (4 Ω)
<b>Nennleistung bei 1 kHz</b>	0,002% (8 Ω) 0,002% (4 Ω)
<b>halbe Nennleistung bei 20 Hz ~ 20 kHz</b>	0,001% (4 Ω)
<b>halbe Nennleistung bei 1 kHz</b>	0,0005% (4 Ω)
<b>-26 dB Leistung bei 1 kHz</b>	0,001% (4 Ω)
<b>50 mW Leistung bei 1 kHz</b>	0,001% (4 Ω)
<b>Intermodulationsfaktor</b>	
<b>Nennleistung bei 250 Hz: 8 kHz = 4:1, 4 Ω</b>	0,002%
<b>Nennleistung bei 60 Hz: 7 kHz = 4:1, nach SMPTE, 8 Ω</b>	0,002%
<b>TIM (Intermodulationsverzerrung)</b> unmeßbar	
<b>Leistungsbandbreite</b>	
beide Kanäle ausgesteuert bei -3 dB T.H.D. 0,01%	5 Hz ~ 100 kHz (4 Ω)

<b>Restbrumm und Geräusch</b>	0,13 mV
<b>Dämpfungsfaktor</b>	50 (4 Ω), 100 (8 Ω)
<b>Eingangsempfindlichkeit und -impedanz</b>	1 V/47 kΩ
<b>Geräuschabstand</b>	108 dB (121 dB nach IHF, A)
<b>Frequenzgang</b>	DC ~ 20 kHz, +0 dB, -0,1 dB DC ~ 150 kHz, +0 dB, -3 dB
<b>Kanalabweichung (250 Hz ~ 6300 Hz)</b>	±0,5 dB
<b>Übersprechdämpfung (1 kHz)</b>	60 dB
<b>Kopfhörerpegel und -impedanz</b>	800 mV/330 Ω
<b>Lautsprecherimpedanz</b>	
<b>MAIN oder REMOTE</b>	4 Ω ~ 16 Ω
<b>MAIN und REMOTE</b>	8 Ω ~ 16 Ω
<b>Instrument</b>	
<b>Anzeigebereich</b>	0,0001 W ~ 300 W (8 Ω) -60 dB ~ +5 dB (logarithmisch)
<b>Frequenzbereich (Ablesegenauigkeit)</b>	
	20 Hz ~ 20 kHz ±2 dB (über -50 dB) 20 Hz ~ 20 kHz ±3 dB (unter -50 dB)

### ALLGEMEINE DATEN

<b>Leistungsaufnahme</b>	950 W
<b>Netzspannung</b>	Wechselstrom 50 Hz/60 Hz, 110V/120V/220V/240V
<b>Abmessungen (B×H×T)</b>	430 × 178 × 416 mm
<b>Gewicht</b>	18,4 kg

#### Bemerkung:

Der Gesamtklirrfaktor wurde mit einem digitalen Rauschspektrometer (Anlage H.P. 3045) gemessen.

Spezifikationen Können infolge von Verbesserungen ohne Ankündigung geändert werden.

## CARACTERISTIQUES

(DIN 45 500)

### SECTION AMPLIFICATEUR

<b>Puissance de sortie continue de 20 Hz~20 kHz,</b>	
les deux canaux en circuit	2 × 150W (8Ω) 2 × 150W (4Ω)
<b>Puissance de sortie continue de 40 Hz~16 kHz,</b>	
les deux canaux en circuit	2 × 150W (8Ω) 2 × 150W (4Ω)
<b>Puissance de sortie continue à 1 kHz</b>	
les deux canaux en circuit	2 × 150W (8Ω) 2 × 150W (4Ω)
<b>Distorsion harmonique totale</b>	
<b>à puissance nominale (20 Hz~20 kHz)</b>	0,002% (8Ω) 0,002% (4Ω)
<b>à puissance nominale (40 Hz~16 kHz)</b>	0,002% (8Ω) 0,002% (4Ω)
<b>à puissance nominale (1 kHz)</b>	0,002% (8Ω) 0,002% (4Ω)
<b>à demi-puissance (20 Hz~20 kHz)</b>	0,001% (4Ω)
<b>à demi-puissance (1 kHz)</b>	0,0005% (4Ω)
<b>puissance de -26 dB à 1 kHz</b>	0,001% (4Ω)
<b>puissance de 50 mW à 1 kHz</b>	0,001% (4Ω)
<b>Distorsion d'intermodulation</b>	
<b>à puissance nominale à 250 Hz: 8 kHz=4:1, 4Ω</b>	0,002%
<b>à puissance nominale à 60 Hz: 7 kHz=4:1, SMPTE, 8Ω</b>	0,002%
<b>TIM (distorsion d'intermodulation transitoire)</b> infiniment petite	
<b>Réponse de fréquences</b>	
les deux canaux en circuit, -3 dB T.H.D. 0,01%	5 Hz~100 kHz (4Ω)
<b>Bruit et ronflement résiduels</b>	0,13 mV
<b>Coefficient d'amortissement</b>	50 (4Ω), 100 (8Ω)

<b>Sensibilité et impédance d'entrée</b>	1 V/47kΩ
<b>Signal/Bruit</b>	108 dB (121 dB, IHF, A)
<b>Réponse de fréquence</b>	DC ~20 kHz, + 0 dB, -0,1 dB DC ~150 kHz, + 0 dB, -3 dB

<b>Equilibrage des canaux, 250 Hz~6,300 Hz</b>	±0,5 dB
<b>Séparation des canaux, 1 kHz</b>	60 dB
<b>Niveau de sortie des casques et impédance</b>	800 mV/330Ω
<b>Impédance de charge</b>	
<b>PRINCIPALE ou AUXILIAIRE (MAIN or REMOTE)</b>	4Ω~16Ω
<b>PRINCIPALE et AUXILIAIRE (MAIN and REMOTE)</b>	8Ω~16Ω

<b>Indicateur</b>	
<b>gamme de lecture</b>	0,0001 W~300 W (8Ω) -60 dB~+5 dB (compression logarithmique)
<b>réponse de fréquence (précision de lecture)</b>	
	20 Hz~20 kHz ±2 dB (plus qu' -50 dB) 20 Hz~20 kHz ±3 dB (moins qu' -50 dB)

### DIVERS

<b>Consommation</b>	950W
<b>Alimentation</b>	CA 50 Hz/60 Hz, 110V/120V/220V/240V
<b>Dimensions (L×H×Pr)</b>	430 × 178 × 416 mm
<b>Poids</b>	18,4 kg

#### Nota:

La Société NATIONAL-PANASONIC-FRANCE, importateur du matériel MATSUSHITA-ELECTRIC déclare que cet appareil est conforme aux prescriptions de la directive 76/889/C.E.E. (arrêté 14 Janvier 1980).

#### Remarque:

On mesure la distorsion harmonique totale au moyen d'un analyseur de spectre digital (Système H.P. 3045).

## ■ ESPECIFICACIONES

(DIN 45 500)

### ■ SECCION AMPLIFICADOR

<b>Potencia continua de 20 Hz~20 kHz en ambos canales</b>	2 × 150W (8Ω) 2 × 150W (4Ω)
<b>Potencia continua de 40 Hz~16 kHz en ambos canales</b>	2 × 150W (8Ω) 2 × 150W (4Ω)
<b>Potencia continua de 1 kHz en ambos canales</b>	2 × 150W (8Ω) 2 × 150W (4Ω)
<b>Distorsión armónica total</b>	
<b>potencia de régimen a 20 Hz~20 kHz</b>	0,002% (8Ω) 0,002% (4Ω)
<b>potencia de régimen a 40 Hz~16 kHz</b>	0,002% (8Ω) 0,002% (4Ω)
<b>potencia de régimen a 1 kHz</b>	0,002% (8Ω) 0,002% (4Ω)
<b>mitad de potencia a 20 Hz~20 kHz</b>	0,001% (4Ω)
<b>mitad de potencia a 1 kHz</b>	0,0005% (4Ω)
<b>-26 dB de potencia a 1 kHz</b>	0,001% (4Ω)
<b>50 mW de potencia a 1 kHz</b>	0,001% (4Ω)
<b>Distorsión por intermodulación</b>	
<b>potencia de régimen a 250 Hz: 8 kHz=4:1, 4Ω</b>	0,002%
<b>potencia de régimen a 60 Hz: 7 kHz=4:1, SMPTE, 8Ω</b>	0,002%
<b>TIM (distorsión intermodular transitoria)</b>	insignificante
<b>Ancho de banda de potencia con ambos canales, -3 dB T.H.D. 0,01%</b>	5 Hz~100 kHz (4Ω)

<b>Zumbido residual y ruido</b>	0,13 mV
<b>Factor de amortiguamiento</b>	50 (4Ω), 100 (8Ω)
<b>Sensibilidad e impedancia de entrada</b>	1V/47 kΩ
<b>Relación de señal a ruido</b>	108 dB (121 dB, IHF, A)
<b>Respuesta de frecuencia</b>	DC ~20 kHz, +0 dB, -0,1 dB DC ~150 kHz, +0 dB, -3 dB
<b>Equilibrio de canales, 250 Hz a 6,300 Hz</b>	±0,5 dB
<b>Separación de canales, 1 kHz</b>	60 dB
<b>Impedancia y nivel de salida de los auriculares</b>	800 mV/330Ω
<b>Impedancia de carga</b>	
<b>MAIN o REMOTE</b>	4Ω~16Ω
<b>MAIN y REMOTE</b>	8Ω~16Ω
<b>Medidor</b>	
<b>campo de lectura</b>	0,0001 W~300 W (8Ω) -60 dB~+5 dB (compresión logarítmica)
<b>respuesta de frecuencia (precisión de lectura)</b>	20 Hz~20 kHz ±2 dB (más de -50 dB) 20 Hz~20 kHz ±3 dB (menos de -50 dB)

### ■ GENERAL

<b>Consumo de energía</b>	950W
<b>Alimentación de energía</b>	CA 50 Hz/60 Hz, 110V/120V/220V/240V
<b>Dimensiones (An.×Al.×Prof.)</b>	430 × 178 × 416 mm
<b>Peso</b>	18,4 kg

#### Nota:

La distorsión armónica total se mide con el analizador de espectro digital (sistema H.P. 3045).

Estas especificaciones están sujetas a cualquier cambio sin previo aviso.

## ■ BEFORE REPAIR AND ADJUSTMENT

1. Turn off the power supply and short-circuit of power supply capacitors (C401 ~ C404, 8200μF) at resistance (about 10Ω, 5W) in order to discharge the charged voltage. Do not short between C401 ~ C404 by screwdriver. It may damage the component.
2. Before turning on the power supply after completion of repair, slowly apply the primary voltage by using a power supply voltage controller to make sure that the consumed current is free of abnormality. The consumed current at 60Hz/50Hz in no signal mode is shown below with respect to supply voltage 110V/120V/220V/240V.

Power supply voltage		AC110V	AC120V	AC220V	AC240V
Cousumed current	50 Hz	410 ~ 930mA	370 ~ 840mA	210 ~ 460mA	190 ~ 440mA
	60 Hz	—	360 ~ 820mA	—	—

MC-Service

# SE-A5MK2

## LOCATION OF CONTROLS

### • Change of Rear panel

[M] area

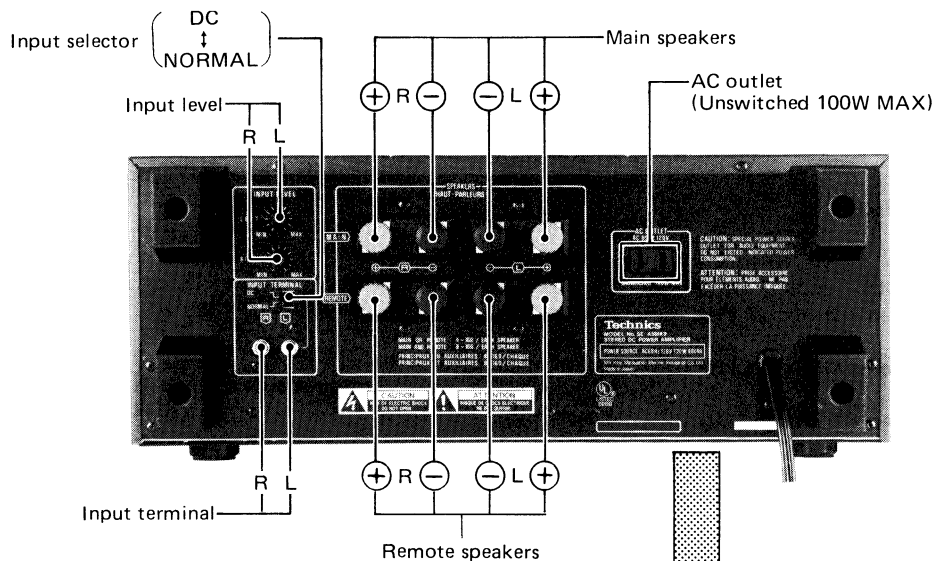

For [D], [EW], [EK], [EF], [XL], [Ei], [EH], [EB] and [EGA] areas.

Change

For [XA], [PA], [PC] and [PE] areas.

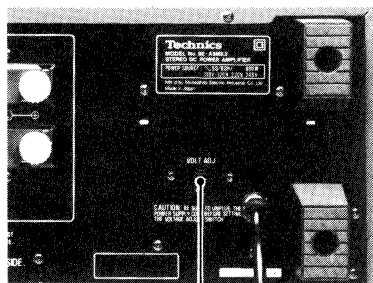

Voltage selector (110V ↔ 120V ↔ 220V ↔ 240V)

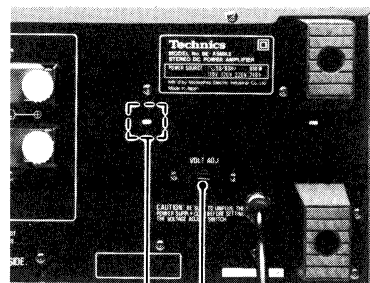

Voltage selector (110V ↔ 120V ↔ 220V ↔ 240V)

AC outlet (Unswitched 50W MAX)

## MESSUNGEN UND JUSTIERUNGEN

### 1. Leerlauf-(ICQ)-Justierung (nach Reparatur des Hauptverstärkers) [Abb. 7]

- (1) Nach erfolgter Reparatur ist der Lautstärkeregel auf Maximum einzustellen, bevor der Netzschalter eingeschaltet wird, und an die Lautsprecher-Ausgangsanschlüsse ist nichts anzuschließen.
- (2) Die ICQ-regler (VR301, VR302) entgegen dem Uhrzeigersinn drehen.
- (3) Die dem Verstärker zugeführte Spannung allmählich von 0V mittels eines Stromversorgungs-Spannungsreglers erhöhen und überprüfen, daß der in der Abbildung auf Seite 4 gezeigte Wert eingehalten wird, bevor mit der Justierung begonnen wird.

- (4) Das elektronische Gleichstrom-Voltmeter an TP301 (+) und TP303 (-) (L. Kanal) oder TP302 (+) und TP304 (-) (R. Kanal) anschließen.
- (5) VR301 (L. Kanal) oder VR302 (R. Kanal) so justieren, daß die Spannung ca. 15 Sekunden nach Einschalten des Netzschalters 4 mV beträgt.

In diesem Gerät wird ICQ durch einen Mikrocomputer geregelt, und ICQ von etwas mehr als dem normalen Pegel wird durch "PREHEAT" ca. 15 Sekunden lang nach Einschalten der Stromzufuhr angelegt. Danach werden der Ausgangspegel und die Transistortemperatur durch "Auto" erfaßt, wodurch ICQ automatisch geregelt wird.

## 2. Pegeljustierung des Spitzenleistungsmeters (nach Reparatur der Meterverstärkungs-Schaltung oder Auswechseln des Spitzenleistungsmeters)

- (1) Den Eingangspegelregler in die Maximum-Position stellen.
- (2) Einen Blindwiderstand von 8 Ohm oder einen Lautsprecher von 8 Ohm Impedanz und ein Wechselstrom-Voltmeter an den Lautsprecheranschluß anschließen.
- (3) Ein 1kHz-Sinuswellensignal an den AUX/CD/VIDEO-Anschluß einspeisen und die Eingangsleistung so regeln, daß die Ausgangsleistung am Lautsprecheranschluß 28,3V beträgt.
- (4) Beide Kanäle mit VR101 (L. Kanal) und VR102 (R. Kanal) so abgleichen, daß das Meter 100W anzeigt.

## 3. Prüfen der Stummschaltung während Ein- und Ausschalten der Stromzufuhr

- (1) Eine 8 Ohm-Last und das Wechselstrom-Voltmeter an den Lautsprecheranschluß anschließeb.
- (2) Den Eingangspegelregler in die Maximum-Position stellen.
- (3) Ein Sinuswellensignal von 1kHz, 0,5V an den Lautsprecheranschluß einspeisen.
- (4) Überprüfen, ob die Ausgangsleistung ca. 3 ~ 5 Sekunden nach Einschalten des Netzschalters ausgegeben wird.
- (5) Die Ausgangsleistung sollte beim Ausschalten des Netzschalters sofort verschwinden.

## MESURAGES ET RÉGLAGES

### 1. Réglage de la marche à vide (ICQ) (après réparation de l'amplif. principal) [Fig. 7]

- (1) Après la réparation, régler le volume sonore au maximum avant de mettre en circuit le commutateur d'alimentation, et ne rien raccorder aux bornes des haut-parleurs.
- (2) Tourner complètement la commande ICQ (VR301, VR302) dans le sens inverse des aiguilles d'une montre.
- (3) Augmenter peu à peu la tension appliquée à l'amplificateur à partir de 0V au moyen d'un contrôleur de tension d'alimentation en courant et s'assurer de la valeur indiquée à la Figure de la page 4 avant de commencer le réglage.
- (4) Raccorder le voltmètre électronique à C.C. à TP301 (+) et à TP303 (-) (Canal de gauche) ou à TP302 (+) et à TP304 (-) (Canal de droite).
- (5) Ajuster VR301 (Canal de gauche) ou VR302 (Canal de droite) de telle sorte que la tension soit de 4mV à peu près 15 secondes après avoir mis en circuit ("on") le commutateur d'alimentation.

Dans cet appareil, ICQ est contrôlé par un micro-ordinateur, et ICQ légèrement plus élevé que le niveau normal est appliqué par "PRECHAUFFAGE" pendant à peu près 15 secondes après la mise sous tension. Après cela, le niveau de sortie et la température du transistor sont détectés par "AUTO", contrôlant automatiquement de ce fait ICQ.

## 4. Prüfen der Gleichstrom-Detektionsschaltung

- (1) Den Eingangspegelschalter in die Maximum-Position stellen.
- (2) Gleichspannung +1V (an L. Kanal) und -1V (an R. Kanal) an den Gleichstrom-Eingangsanschluß anlegen.
- (3) Überprüfen, daß
  - das Relais ausgeschaltet ist.
  - die "auto"-Anzeige erlöscht.
  - die "safety operation"-Anzeige blinkt.

## 5. Prüfen der Überlast-Detektions- und Schutzschaltung

- (1) Eine 8 Ohm-Last (Widerstand oder Lautsprecher) und Wechselstrom-Voltmeter an den Hauptlautsprecher-Anschluß anschließen.
- (2) Den Hauptlautsprecher-Wahlschalter in die "on"-Position stellen.
- (3) Einen 0,33 Ohm-Widerstand (5W) and den Nebenlautsprecher-Anschluß anschließen.
- (4) Ausgangssignal von ca. 5V (1kHz) an den Eingangsanschluß eingeben.
- (5) Überprüfen, daß keine Ausgangsleistung ausgegeben wird, wenn der Nebenlautsprecher-Schalter auf "on" gestellt wird.

Wenn die Schutzschaltung aktiviert wird, funktioniert das Gerät erst wieder nach Aus- und Wiedereinschalten der Stromzufuhr.

## 2. Réglage du niveau du mesureur de puissance de crête (après la réparation du circuit de l'amplificateur du mesureur ou le remplacement du mesureur de puissance de crête).

- (1) Régler l'ajustement du niveau d'entrée sur la position maximale.
- (2) Raccorder une résistance fictive de 8Ω ou un haut-parleur d'une impédance de 8Ω et un voltmètre à C.A. à la borne du haut-parleur.
- (3) Appliquer une onde sinusoïdale de 1kHz à la borne AUX/CD/VIDEO et régler l'entrée de telle sorte que la puissance de sortie à la borne du haut-parleur soit de 28,3V.
- (4) Ajuster à la fois les canaux de VR101 (Canal de gauche) et de VR102 (Canal de droite) de telle sorte que l'indication du mesureur soit de 100W.

## 3. Vérification du circuit d'accord silencieux pendant le fonctionnement de la "mise en circuit" - "hors circuit" de l'énergie.

- (1) Raccorder une charge de 8Ω et un voltmètre à C.A. à la borne du haut-parleur.
- (2) Régler l'ajustement du niveau d'entrée à la position maximale.
- (3) Appliquer une onde sinusoïdale de 1kHz de 0,5V à la borne du haut-parleur.
- (4) S'assurer que la puissance de sortie soit délivrée à peu près 3 ~ 5 secondes après la mise en circuit ("on") de l'interrupteur d'alimentation.
- (5) La puissance de sortie devra immédiatement se modifier lorsque l'interrupteur d'alimentation est tourné sur la "mise hors circuit" ("off").

## 4. Vérification du circuit de détection à C.C.

- (1) Régler l'ajustement du niveau d'entrée sur la position maximale.
- (2) Appliquer une tension C.C. de +1V (au canal gauche) et de -1V (au canal droit) à la borne d'entrée à C.C.
- (3) S'assurer que
  - le relais soit hors circuit.
  - la "mise en circuit" de l'indicateur "auto" s'éteigne.
  - l'indicateur du "fonctionnement de sécurité" clignote.

## 5. Vérification de la détection de surcharge et du circuit de protection.

- (1) Raccorder 8Ω (résistance ou haut-parleur) et un voltmètre à C.C. à la borne du haut-parleur principal.

- (2) Le sélecteur du haut-parleur principal est sur la position de "mise en circuit" ("on").
- (3) Raccorder une résistance de 0,33Ω (5W) à la borne du haut-parleur auxiliaire.
- (4) Appliquer un signal de sortie d'environ 5V à 1kHz à la borne d'entrée.
- (5) S'assurer qu'aucune puissance de sortie ne soit délivrée lorsque le commutateur du haut-parleur auxiliaire est réglé sur "on" (mise en circuit).

Lorsque l'ensemble des circuits de protection fonctionne, l'appareil ne se mettra pas en marche à moins que l'énergie ne soit d'abord mise hors circuit puis remise à nouveau en circuit.

## MEDICIONES Y AJUSTE

### 1. Ajuste de marcha en vacío (ICQ) (Después de reparar el amplificador principal.) [Fig. 7]

- (1) Después de la reparación, ponga el volumen de sonido en máximo antes de conectar el interruptor de corriente, y no conecte nada a los terminales de altavoz.
- (2) Gire completamente el control ICQ (VR301, VR302) a la izquierda.
- (3) Aumente el voltaje aplicado al amplificador gradualmente desde 0V por medio del controlador de voltaje de suministro de energía, y asegúrese del valor en la Figura de la página 4 antes de comenzar el ajuste.
- (4) Conecte el voltímetro electrónico de CC a TP301 (+) y TP303 (-) (Ch. I) o TP302 (+) y TP304 (-) (Ch. D).
- (5) Ajuste VR301 (Ch. I) o VR302 (Ch. D) de manera que el voltaje sea 4mV unos 15 seg. después de poner en "on" (conectado) el interruptor de alimentación.

En este aparato, ICQ es controlado mediante micro-computador, y ICQ, un poco más del nivel normal, es aplicado "PRECALENTAMIENTO" por unos 15 seg. después de conectar. Después de eso, el nivel de salida y temperatura de transistor son detectados mediante "AUTO", por lo cual controlando automáticamente ICQ.

### 2. Ajuste de nivel de medidor de potencia de cresta (después de reparar el circuito de amp. de medidor o reemplazar el medidor de potencia de cresta.)

- (1) Ponga el ajuste de nivel de entrada en la posición máxima.
- (2) Conecte un resistor ficticio de 8Ω o un altavoz de impedancia de 8Ω y voltmetro CA al terminal de altavoz.
- (3) Aplique onda sinusoidal al terminal AUX/CC/VIDEO y ajuste la entrada de manera que la salida a la terminal de altavoz sea 28,3V.
- (4) Ajuste ambos canales de VR101 (Ch. I) y VR102 (Ch. D) de manera que la indicación del medidor sea 100W.

### 3. Comprobación de circuito silenciador durante operación de "conexión" - "desconexión" de corriente.

- (1) Conecte una carga de 8Ω y un voltímetro de CA al terminal de altavoz.
- (2) Ponga el ajuste de nivel de entrada en la posición máxima.
- (3) Aplique onda sinusoidal de 1kHz, 0,5V al terminal de altavos.
- (4) Asegúrese de que la salida es suministrada unos 3 ~ 5 seg. después de poner en "on" (conectado) el interruptor de alimentación.
- (5) Salida debe desaparecer inmediatamente cuando se pone en "off" (desconectado) el interruptor de alimentación.

### 4. Comprobación de circuito de detección de CC

- (1) Ponga el ajuste de nivel de entrada en la posición máxima.
- (2) Aplique voltaje CC + 1V (a Ch. I), -1V (a Ch. D) al terminal de entrada de CC.
- (3) Asegúrese de que
  - el relé está en "off".
  - indicador "auto" "on" se apaga.
  - indicador de "operación segura" parpadea.

### 5. Comprobación de detección de sobrecarga y circuito de protección

- (1) Conecte 8Ω (resistor o altavoz) y voltmetro CA al terminal de altavoz principal.
- (2) Selector de altavoz principal está en posición "on".
- (3) Conecte resistor de 0,33Ω (5W) al terminal de altavoz remoto.
- (4) Aplique señal de salida de unos 5V a 1kHz a terminal de entrada.
- (5) Asegúrese de que no se suministra salida cuando el interruptor de altavoz remoto es puesto en "on".

Cuando la circuitería de protección funciona, la unidad no operará a no ser que primero se desconecte la corriente y luego se conecte de nuevo.

## CHANGE

### CHANGE OF THE REPLACEMENT PARTS LIST

**Notes:** 1. part numbers are indicated on most mechanical parts. Please use this part number for parts orders.  
2. Important safety notice: Components identified by  $\Delta$  mark have special

characteristics important for safety. When replacing any of these components use only manufacturer's specified parts.  
3. The "S" mark is service standard parts and differ from production parts.

Ref. No.	Change of Part No.		Pcs.	Part Name & Description
	SE-A5MK2 [M]	SE-A5MK2 [D,EW,EK,EF,XA,PE,PA,XL,EI,EH,EB,PC,EGA]		
<b>COILS</b>				
L1, 2	Addition	ELQ050D15		Choke [EGA] only
L901~904	Addition	SLQY07G-30		Choke [EGA] only
<b>TRANSFORMERS</b>				
T502	$\Delta$	SLT5S68	SLT5S69	Power Source
T501	$\Delta$	SLT5L178	SLT5L178-1	Meter
<b>FUSES</b>				
F1	$\Delta$	XBA1F80NU14	XBA2C40TR0	250V, T4A
F2	$\Delta$	XBA2F03NU100	XBA2C40TR0	250V, T4A
F3	$\Delta$	Addition	XBA2C03TR0	250V, T315mA
<b>SWITCHES</b>				
S501	$\Delta$	ESB9939T	ESB90227S	Power Source [EGA] only
S601	$\Delta$	Addition	ESB99399S	Power Source [Other areas]
S601	$\Delta$	Addition	ESE37200	Voltage Selection
<b>CAPACITORS</b>				
C3, 4	$\Delta$	Addition	ECKDKC222MF2	0.0022 $\mu$ F, [EGA] only
C5, 6	$\Delta$	Addition	ECKDKC222MF2	0.0022 $\mu$ F, [EGA] only
C7	$\Delta$	Addition	ECQE2A473MM	0.047 $\mu$ F, [EGA] only
C8	$\Delta$	Addition	ECQE2104KZ	0.1 $\mu$ F, [D, EF, EGA, EI, EH, EB] only
C901~904	Addition	ECKD1H681KB		680pF, [EGA] only
C905~908	Addition	ECQM1H103KV		0.01 $\mu$ F, [EGA] only
C1001	$\Delta$	Addition	ECKDKC103PF2	0.01 $\mu$ F
C1002	$\Delta$	Addition	ECKDKC103PF2	0.01 $\mu$ F, [EGA] only
<b>RESISTORS</b>				
R401~404	$\Delta$	ERD2FG5R6	ERD25FJ2R2	2.2 $\Omega$
R407, 408	$\Delta$	Addition	ERD25FJ2R2	2.2 $\Omega$
<b>CABINET and CHASSIS PARTS</b>				
25		SJT345	SJT347	(6) Holder, Fuse
40	$\Delta$	SHR129	SHR129	(1) Bushing, AC Cord, [EK] only
			SHR127	(1) Bushing, AC Cord, [EW, XA, PA, PE, PC] only
			SHR131	(1) Bushing, AC Cord, [Other areas]
41	$\Delta$	SJA129-1	SWY117	(1) AC Cord, [WE] only
			SJA121	(1) AC Cord, [XA, PA, PE, PC] only
			QFC1205M	(1) AC Cord, [EK] only
			QFC1207MA	(1) AC Cord, [XL] only
		SWY143	(1) AC Cord, [Other areas]	

Ref. No.	Change of Part No.		Pcs.	Part Name & Description
	SE-A5MK2 [M]	SE-A5MK2 [D,EW,EK,EF,XA,PE,PA,XL,EI,EH,EB,PC,EGA]		
42	$\Delta$	SJS9221	SJS9221	(1) Socket, [XA, PA, PE, PC] only
43		SGP2391C	SGP2391-2A	(1) Rear Panel, [EW]
			SGP2391-3A	(1) Rear Panel, [XA, PA, PE, PC]
			SGPEA5MK2-KK	(1) Rear Panel, [EK]
			SGPEA5MK2-KE	(1) Rear Panel, [D]
49	Addition	SMN1685-3	(1) Rear Panel, [Other areas]	
				(1) Bracket, P.C.B.
<b>SCREWS</b>				
N12	Addition	XTBS3+8BFZ1	(1)	Tapping, $\oplus$ 3 x 8 [EGA] only
		XTW3+8H	(1)	Tapping, $\oplus$ 3 x 8 [Other areas]
N13	Addition	XTW3+8H	(1)	Tapping, $\oplus$ 3 x 8
N14	Addition	XTBS3+8BFZ1	(2)	Tapping, $\oplus$ 3 x 8
N30	Addition	XSN3+6BVS	(2)	$\oplus$ 3 x 6
<b>WASHER</b>				
M31	Addition	XWA3BFZ	(2)	Spring, $\phi$ 3
<b>ACCESSORIES</b>				
A2		SQF12032	SQF12035	(1) Instruction Book, [XA, PC]
			SQF12036	(1) Instruction Book, [PA, PE]
			SQF12037	(1) Instruction Book, [EGA]
			SQF12034	(1) Instruction Book, [Other areas]
A3	$\Delta$	Addition	SJP9215	(1) Plug, [XA, PA, PE, PC] only
<b>PACKING PARTS</b>				
P5		SPG4787	SPG4835	(1) Carton Box, [EK]
			SPG4790	(1) Carton Box, [EF]
			SPG4787	(1) Carton Box, [EW, XA, PA, PE, PC]
P6	Addition	SPS4413	SPG4789	(1) Carton Box, [Other areas]
			SPS4413	(1) Pad, [D, EGA, EF, EI, EH, EB, XL]

### Change of Power Supply

[M] area

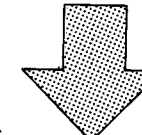
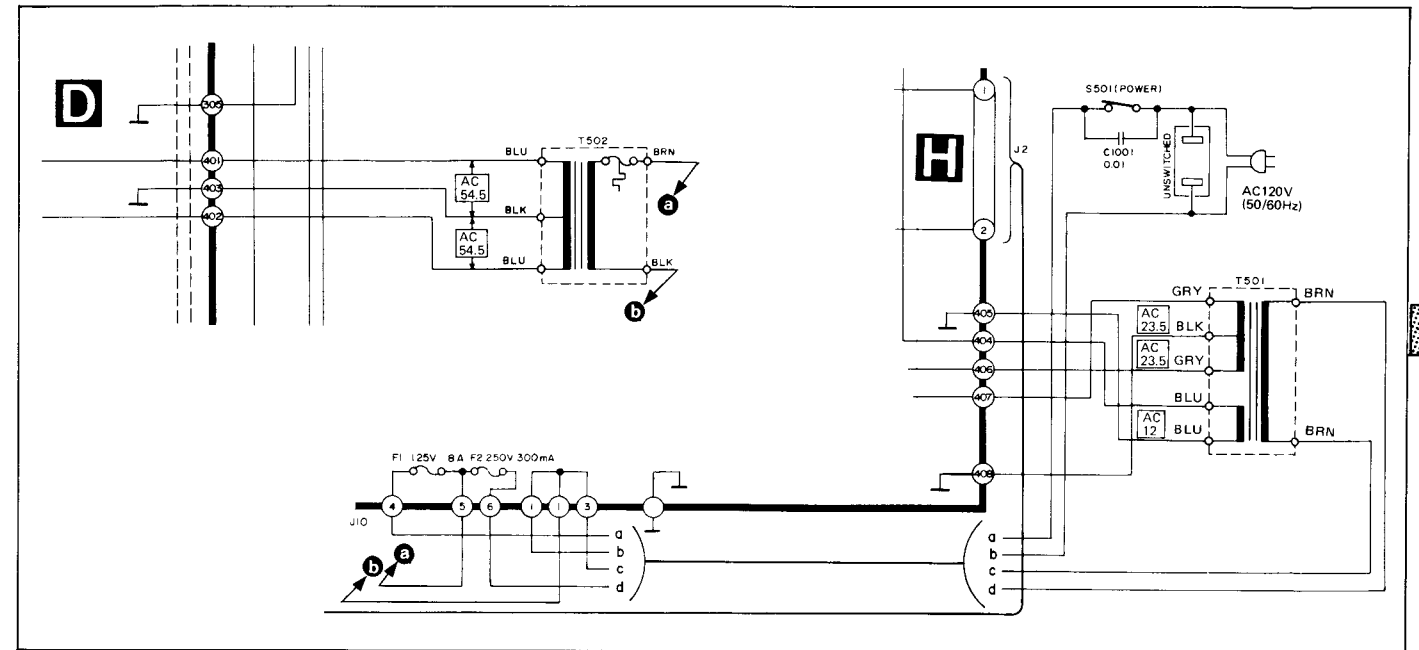

For [D],[EW],[EK],[EF],[XL],[EI],[EH] and [EB] areas

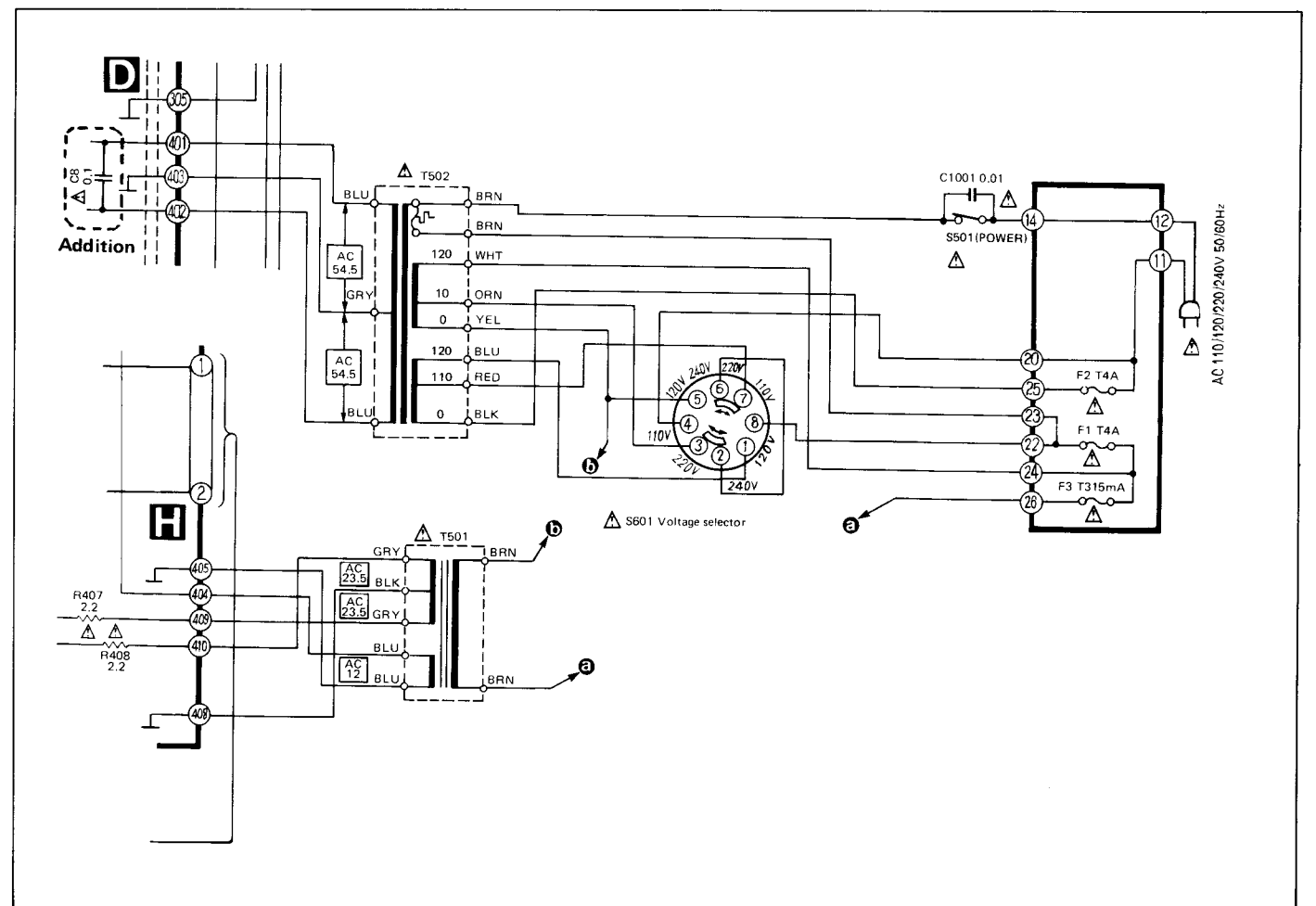

### SCHEMATIC DIAGRAM

#### Change of Speaker Terminal Circuit

Additional parts

[M] area

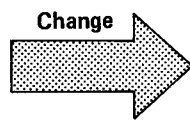
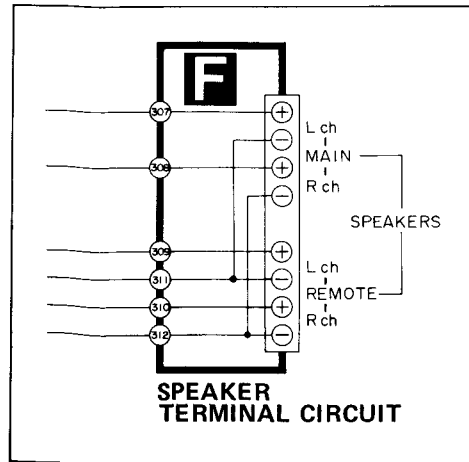

For [EGA] area

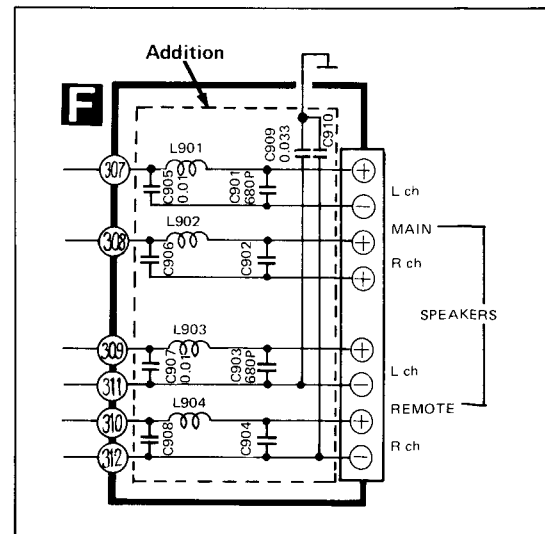

For [XA],[PC],[PA] and [PE] areas

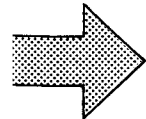
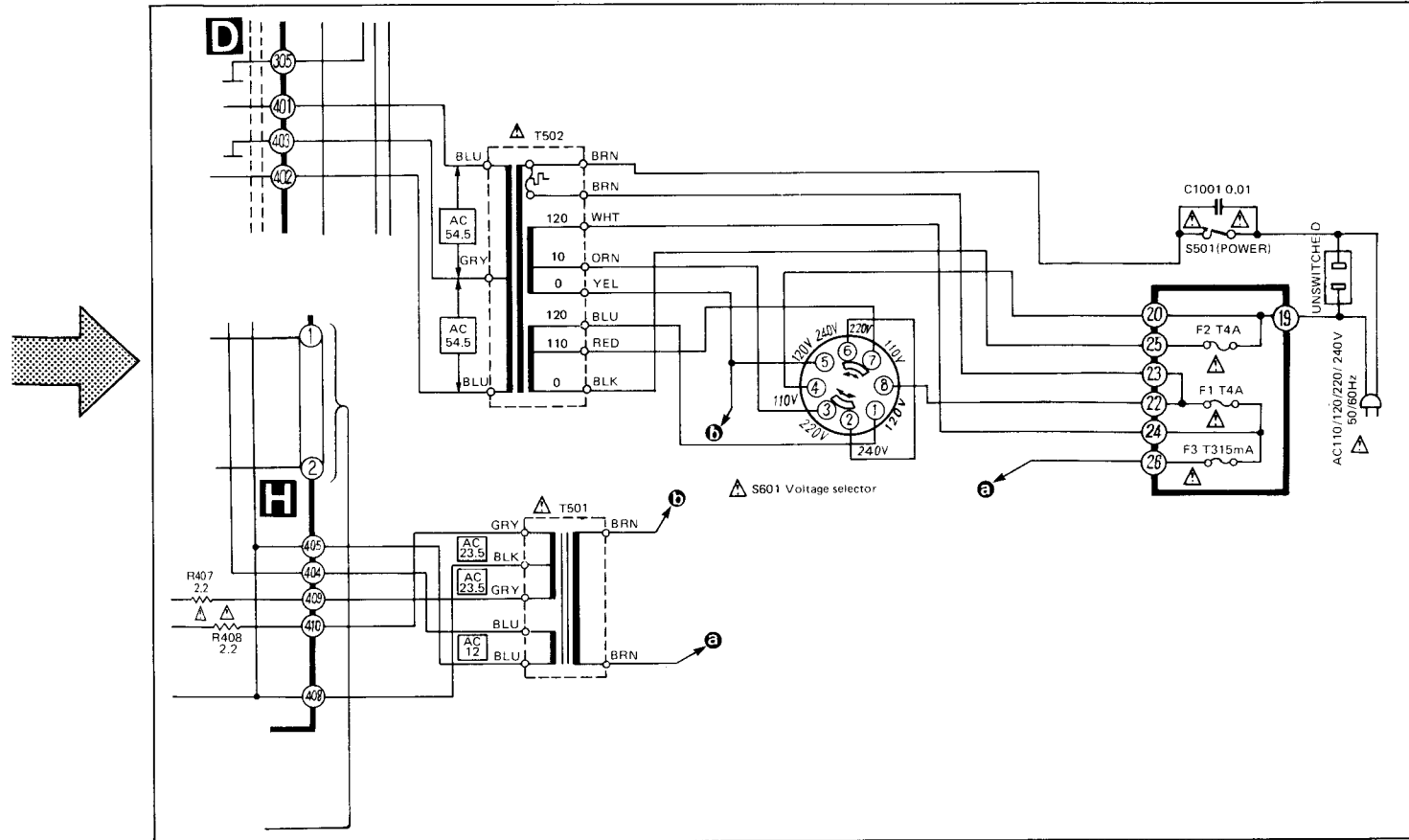

• Change of Meter Power Source

For [D],[EW],[EK],[EF],[XL],[Ei],[EH] and [EB] areas

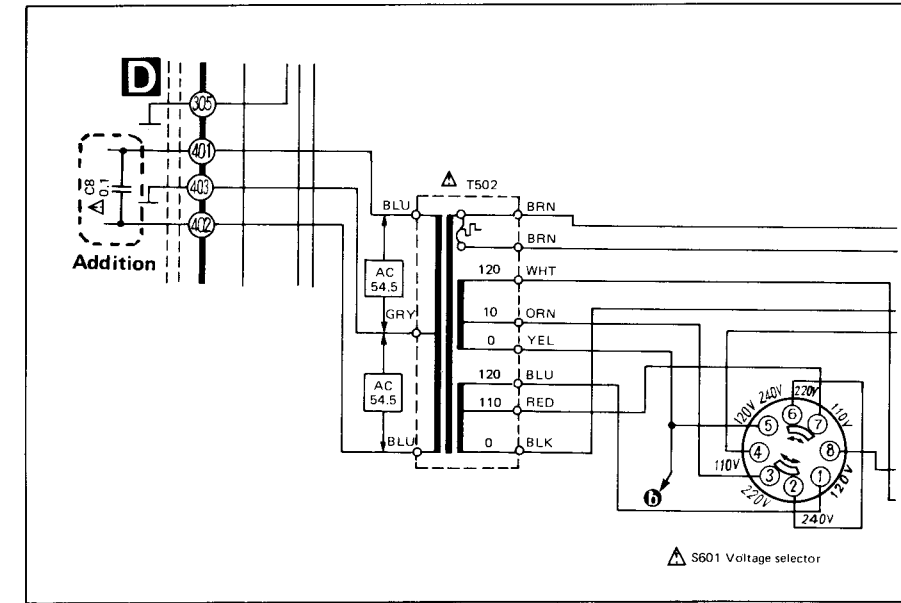

• Change of Exploded View

For [EGA] area

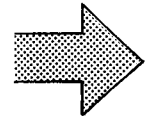
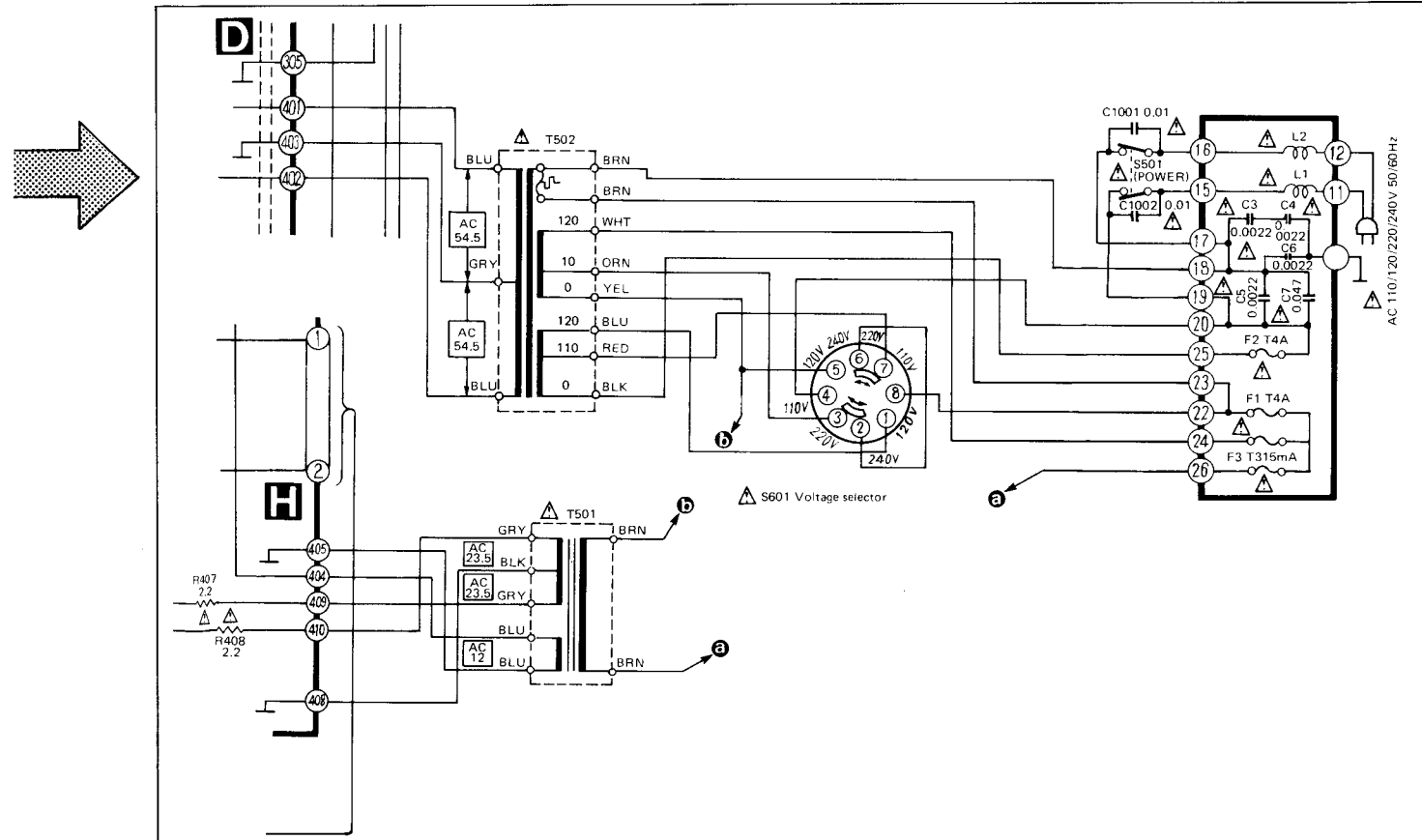

[M] area

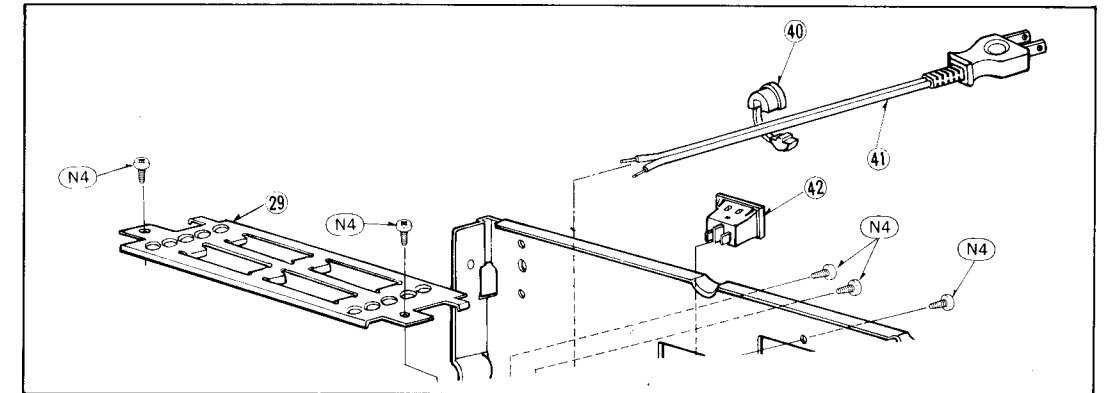

For [D],[EW],[EK],[EF],[EGA],[Ei],[EH],[EB],[XA],[XL],[PA],[PE] and [PC] areas

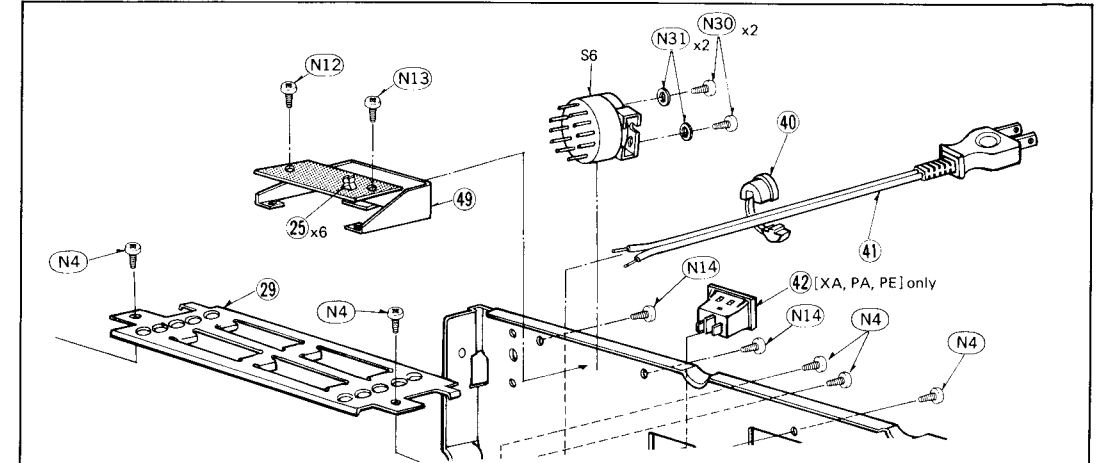

**Important safety notice:**

Components identified by  $\Delta$  mark have special characteristics important for safety. When replacing any of these components, use only manufacturer's specified parts.

# SE-A5MK2 SE-A5MK2

## REPLACEMENT PARTS LIST

### Notes:

- Part numbers are indicated on most mechanical parts. Please use this part number for parts orders.
- Important safety notice: Components identified by  $\Delta$  mark have special characteristics important for safety. When replacing any of these components use only manufacturer's specified parts.
- Bracketed indications in Ref. No. columns specify the area. Parts without these indicators can be used for all areas.
- The "Ⓢ" mark is service standard parts and may differ from production parts.
- The parenthesized numbers in the column of description stand for the quantity per set.

### Areas

- \* [D] is available in Scandinavia.
- \* [EW] is available in Switzerland.
- \* [EK] is available in United Kingdom.
- \* [EF] is available in France.
- \* [XA] is available in Southeast Asia, Oceania, Africa, Middle Near East and Central South America.
- \* [PE] is available in European Military.
- \* [PA] is available in Far East PX.
- \* [XL] is available in Australia.
- \* [Ei] is available in Italy.
- \* [EH] is available in Holland.
- \* [EB] is available in Belgium.
- \* [PC] is available in European Audio Club.
- \* [EGA] is available in Germany.

Ref. No.	Part No.	Part Name & Description
<b>INTEGRATED CIRCUITS</b>		
IC21	MN1404STE	ICQ Controller
IC101, 102	SVITA7318P	Meter Drive
IC301	AN6552F	DC Servo
<b>TRANSISTORS</b>		
Q21~29, 101 102, 313, 314 337, 338, 401 503, 505, 601 703, 704	2SC1815-Y	Signal Detector, DC Detector, Indicator Drive, Regulator, Muting, Current Stabilizer, Bias Control, ICQ Control, Switching
Q301~304	2SK117-GR	FET Differential Amp.
Q305~308	2SC1815-G	Cascade
Q309~312	2SC1845-E	Differential Amp.
Q315~318, 323 324	2SA1370-D	Current Mirror, Pre Drive, Drive
Q319~322	2SC3467-D	Pre Drive, Drive
Q325, 326	2SC3298A-Y	Class A Drive
Q327, 328	2SA1306A-Y	Class A Drive
Q329~332	2SC3280-R	Power Amp.
Q333~336	2SA1301-R	Power Amp.
Q402, 602	2SA1015-Y	Regulator, Relay Drive
Q501, 502	2SC1845-E	Over load Detector
Q504	2SD1265-O	Regulator
Q701, 702	2SC3467-D	Current Detector
Q705, 706	2SA1370-D	Switching
Q707, 708	2SC2632-R	Switching
Q709, 710	2SA1124-R	Voltage Control
<b>DIODES</b>		
D21, 22 Ⓢ 301~306 501~506 601~603 711~714	MA162A	Switching
D23	MA1062M	Zener, 6, 2V
D307~310	MA182	Switching
D311~318	OA90A-R	
N319~322	MA27W-A	
D401, 402 $\Delta$	SVDS10V820F	Rectifier
D405~412 Ⓢ $\Delta$	SVDSR1K2	Rectifier
D413, 414	SVDMZ316A	Zener, 16V
D507	SVDMZ318	Zener, 18V
D705~708	SVDMZ316B	Zener, 16V
D709, 710	MA27B	
D715, 716	SVDMZ322A	Zener, 22V
<b>COILS</b>		
L1, 2 [EGA] only	ELQ050D15	Choke
L301, 302	SLQY15G-30	Choke
L901~904 [EGA] only	SLQY07G-30	Choke
<b>TRANSFORMERS</b>		
T502	SLT5569	Power Source
T501	SLT5L178-1	Meter
<b>VARIABLE RESISTORS</b>		
VR101, 102	EVNK6AA00B32	Power Meter Adj., 300 $\Omega$ (B)
VR201, 202	EVH6UA524B54	Input Level, 50k $\Omega$ (B)
VR301, 302	EVNK6AA00B13	ICQ Adj., 1k $\Omega$ (B)
<b>THERMISTERS</b>		
TH301, 302	ERTD2ZHL333S	33k $\Omega$

Ref. No.	Part No.	Part Name & Description
<b>COMPONENT COMBINATIONS</b>		
Z401~403 $\Delta$	SXRFS203ZSM	0.01 $\mu$ F( $\times$ 2)
<b>THERMAL DETECTOR</b>		
PS501	SRPBG47101	60°C(140°F)
<b>RELAY</b>		
RLY601, 602 $\Delta$	SSY124	Speaker
RLY603 $\Delta$	SSY9	Meter
<b>LAMP</b>		
PL1~18	XAMR74S17	Meter (12V, 0.055 A)
PL19~21	XAMR48S230	Computer Drive, Safety Operation, Power(12V, 0.04A)
PL22~24	XAMR48T250	Speaker Ind. (12 V, 0.04A)
<b>METER</b>		
	SSM161-1	Peak Power Meter
<b>FUSES</b>		
F1, 2 $\Delta$	XBA2C40TRO	250V, T4A
F3 $\Delta$	XBA2C03TRO	250V, T315mA
<b>SWITCHES</b>		
S1	SSS49	Input Selector
S2	SSH475	Speaker
S501 [EGA] only $\Delta$	ESB90227S	Power Source
S501 [other areas] $\Delta$	ESB99399S	Power Source
S601 $\Delta$	ESE37200	Voltage Selec tor
<b>CABINET PARTS and CHASSIS PARTS</b>		
1	SBC645-1A	Button, (off) (1)
2	SBC645-1B	Button, (main) (1)
3	SBC645-1C	Button, (remote) (1)
4	SBC645-1D	Button, (main and remote) (1)
5	SUS191-2	Spring, Button (4)
6	SGWEA5MK2-KM	Front Panel, Ass'y (1)
7	SHG6349	Rubber (4)
8	SGE693-1	Bracket, Left (1)
9	SGE693	Bracket, Right (1)
10	SGE697	Reflector Plate (1)
11	SGEEA5MK2-KN	Ornament (1)
12	SDE259-1	Filter, Lamp (1)
13	SMP305	Case, Lamp (1)
14	SUW2155	Bracket, Lamp Case (1)
15	SHG1575	Rubber, Lamp (6)
16	SHP9379	Sheet, Lamp (2)
17	SMP293	Bracket, Lamp (1)
18	SMK61	Bracket, Headphone (1)
19	SJJ71B	Jack, Headphone(1)
20	SUW1955	Bracket, Meter (1)
21	SBC627	Button, Power Source (1)
22	SDU35-1	Filter, Meter (1)
23	SHS6129	Sheet (2)
24	SMP371	Reflector Plate (1)
25	SJT347	Holder, Fuse (6)
26	SKCEA5MK2-KM	Cabinet (1)

Ref. No.	Part No.	Part Name & Description
27	SML101-1	Bracket, Power Transformer (1)
28	SUW2153-3	Bracket (1)
29	SMN1895-1	Bracket (1)
30	SUW1595	Bracket (1)
31	SUW1701	Bracket (1)
32	SUW1593	Bracket (1)
33	SUW2153-2	Bracket (1)
34	SKU8210-3	Bottom Board (1)
35	SKL247-2	Foot, Bottom Side (4)
36	SJF3225-2A	Terminal Board (1)
37	SMN1729-1	Bracket, Input Level Volume (1)
38	SJT231	Terminal (1)
39	SJF4817	Terminal Board, Speaker (1)
40 [EK]	SHR129	Bushing, AC Cord (1)
40 [EW, XA, PA, PE, PC]	SHR127	Bushing, AC Cord (1)
40 other areas	SHR131	Bushing, AC Cord (1)
41 [EW] $\Delta$	SWY117	AC Cord (1)
41 [XA, PA, PE, PC] $\Delta$	SJA121	AC Cord (1)
41 [EK] $\Delta$	QFC1205M	AC Cord (1)
41 [XL] $\Delta$	QFC1207MA	AC Cord (1)
41 other areas $\Delta$	SWY143	AC Cord (1)
42 [XA, PA, PE, PC] only $\Delta$	SJS9221	Socket, AC Outlet (1)
43 [EW]	SGP2391-2A	Rear Panel (1)
43 [XA, PA, PE, PC] only	SGP2391-3A	Rear Panel (1)
43 [EK]	SGPEA5MK2-KK	Rear Panel (1)
43 [D]	SGPEA5MK2-KE	Rear Panel (1)
43 other areas	SGP2391-1A	Rear Panel (1)
44	SBN613	Knob, Input Level Volume (2)
45	SKL241	Foot, Rear Side (4)
46	SHG1509	RUBber, Button (4)
47	SHS2445	Sheet (2)
48	SHS2437	Sheet (1)
49	SMN1685-3	Bracket, P. C. B. (1)
<b>SCREWS</b>		
N1	Ⓢ XTBS3+8BFZ	Tapping, $\Phi$ 3 $\times$ 8 (3)
N2	Ⓢ XTS3+8BFZ	Tapping, $\Phi$ 3 $\times$ 8 (4)
N3	Ⓢ XSN3+6S	$\Phi$ 3 $\times$ 6 (4)
N4	XTBS3+8BFZ1	Tapping with Detent, $\Phi$ 3 $\times$ 8 (4)
N5	Ⓢ XTN3+8B	Tapping, $\Phi$ 3 $\times$ 8 (2)
N6	XSS5+12FIS	$\Phi$ 5 $\times$ 12 (8)
N7	Ⓢ XTBS4+10BFN	Tapping, $\Phi$ 4 $\times$ 10(2)
N8	XTB4+8F	Tapping, $\Phi$ 4 $\times$ 8 (8)
N9	XTW3+12J	Tapping, $\Phi$ 3 $\times$ 12(8)
N10	XTB3+10FFZ	Tapping, $\Phi$ 3 $\times$ 10(4)
N11	XTB4+12FFZ	Tapping, $\Phi$ 4 $\times$ 12(4)
N12 [EGA] only	XTBS3+8BFZ1	Tapping with Detent, $\Phi$ 3 $\times$ 8 (1)
N12 other areas	XTW3+8H	Tapping, $\Phi$ 3 $\times$ 8 (1)
N13	XTW3+8H	Tapping, $\Phi$ 3 $\times$ 8 (1)

Ref. No.	Part No.	Part Name & Description
N14	XTBS3+8BFZ1	Tapping with Detent, $\Phi$ 3 $\times$ 8 (2)
N30	XSN3+6BVS	$\Phi$ 3 $\times$ 6 (2)
<b>WASHERS</b>		
N15	Ⓢ XWA3B	Spring, $\phi$ 3 (5)
N16	Ⓢ XWG3	Plain, $\phi$ 3 (2)
N17	SNE59-1	(1)
N18	Ⓢ XWC3B	External Toothed Lock, $\phi$ 3 (1)
N31	Ⓢ XWA3BFZ	Spring $\phi$ 3 (2)
<b>NUTS</b>		
N20	Ⓢ XNS12	$\phi$ 12 (1)
N21	Ⓢ XNG3ES	$\phi$ 3 (1)
N22	SNE4021	(2)
<b>ACCESSORIES</b>		
A1	SJP2239	Cord, Connection (1)
A2 [XA, PC]	SQF12035	Instruction Book (1)
A2 [PA, PE]	SQF12036	Instruction Book (1)
A2 [EGA]	SQF12037	Instruction Book (1)
A2 other areas	SQF12034	Instruction Book (1)
A3 [XA, PA, PE, PC] only $\Delta$	SJP9215	Plug, AC (1)
<b>PACKING PARTS</b>		
P1	SPP653	Polyethylene Bag (1)
P2	SPH211	Sheet (1)
P3	SPS4303-1	Pad, Bottom (1)
P4	SPS4305-2	Pad, Upper (1)
P5 [EK]	SPG4835	Carton Box (1)
P5 [EF]	SPG4790	Carton Box (1)
P5 [EW, XA, PA, PE, PC]	SPG4787	Carton Box (1)
P5 other areas	SPG4789	Carton Box (1)
P6 [D, EGA, EF, Ei, EH, EB, XL] only	SPS4413	Pad, Rear (1)

MC-Service



# Service Manual

## Stereo DC Power Amplifier SE-A5MK2

[M], [MC]

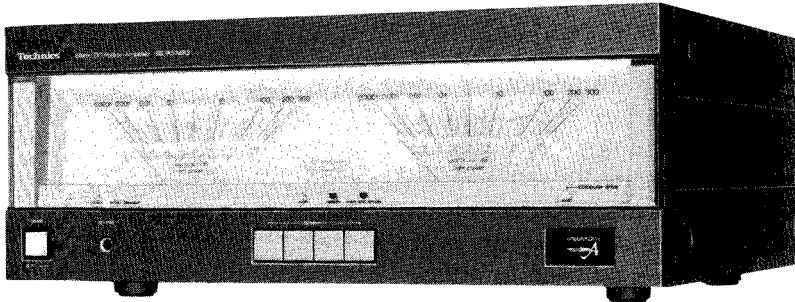

### Areas

- \* [M] is available in the U.S.A.
- \* [MC] is available in Canada.

## Specifications

Specifications are subject to change without notice for further improvement.  
Weights and dimensions shown are approximate.

(IHF '78)

### ■ AMPLIFIER SECTION

#### Rated minimum sine wave RMS power output

20 Hz~20 kHz both channels driven  
0.002% total harmonic distortion  
150W per channel (8 ohms)

20 Hz~20 kHz both channels driven  
0.002% total harmonic distortion  
150W per channel (4 ohms)

#### 1 kHz continuous power output

both channels driven  
0.002% total harmonic distortion  
150W per channel (8 ohms)

0.002% total harmonic distortion  
150W per channel (4 ohms)

Dynamic headroom 1.5 dB (8 ohms)  
3.6 dB (4 ohms)

#### Total harmonic distortion

rated power at 20 Hz~20 kHz 0.002% (8/4 ohms)  
half power at 20 Hz~20 kHz 0.001% (8 ohms)  
half power at 1 kHz 0.0005% (8 ohms)

#### Power bandwidth

both channels driven, -3 dB T.H.D. 0.01%  
5 Hz~100 kHz (8 ohms)

Transient intermodulation distortion unmeasurably small

SMPT E intermodulation distortion 0.002% (8 ohms)

#### Frequency response

DC~20 kHz (+0 dB, -0.1 dB)  
DC~150 kHz (+0 dB, -3 dB)

Input sensitivity 90 mV (1V, IHF '66)  
S/N (IHF, A) 102 dB (121 dB, IHF '66)  
Residual hum and noise 0.13 mV  
Input impedance 47 kilohms  
Low frequency damping factor 100 (8 ohms)  
50 (4 ohms)

#### Load impedance

MAIN or REMOTE 4~16 ohms  
MAIN and REMOTE 8~16 ohms

#### Meter

reading range 0.0001W~300W  
-60 dB ~+5 dB  
(logarithmic compression)

#### frequency response (reading accuracy)

20 Hz~20 kHz  $\pm 2$  dB (more than -50 dB)  
20 Hz~20 kHz  $\pm 3$  dB (less than -50 dB)

### ■ GENERAL

Power consumption 720W, 900 VA

Power supply AC 120V, 60 Hz

#### Dimensions (W×H×D)

430 × 178 × 416 mm  
(16-15/16" × 7" × 16-3/8")

#### Weight

18.4 kg  
(40.61 lb.)

#### Note:

Total harmonic distortion is measured by the digital spectrum analyzer (H.P. 3045 system).

# Technics

MC-Service

Matsushita Engineering and  
Service Company  
50 Meadowland Parkway,  
Secaucus, New Jersey 07094

Panasonic Hawaii Inc.  
91-238 Kauhū St. Ewa Beach  
P.O. Box 774  
Honolulu, Hawaii 96808-0774

Matsushita Electric  
of Canada Limited  
5770 Ambler Drive, Mississauga,  
Ontario, L4W 2T3

Panasonic Sales Company,  
Division of Matsushita Electric  
of Puerto Rico, Inc.  
Ave. 65 Defensoría, KM 9.7  
Victoria Industrial Park  
Carolina, Puerto Rico 00630

# SE-A5MK2

## CONTENTS

	Page		Page
FEATURE	2	TERMINAL NAMES AND FUNCTION OF I <sub>CO</sub>	
SAFETY PRECAUTION	2	CONTROL (MN1404STE)	14
LOCATION OF CONTROLS	3	DESCRIPTION OF I <sub>CO</sub> CONTROL CIRCUIT	15, 16
PROTECTION CIRCUITRY	4	CURRENT DETECTION TYPE VOLTAGE	
BEFORE REPAIR AND ADJUSTMENT	4	CONTROL CIRCUIT	16
DISASSEMBLY INSTRUCTIONS	4, 5	BLOCK DIAGRAM	17, 18
MEASUREMENTS AND ADJUSTMENTS	6, 7	SCHEMATIC DIAGRAM	19 ~ 22
RESISTORS & CAPACITORS	7, 8	REPLACEMENT PARTS LIST	23
PRINTED CIRCUIT BOARDS	8 ~ 11	EXPLODED VIEWS	24 ~ 26
CIRCUIT BOARDS AND WIRING CONNECTION			
DIAGRAM (Top View)	12, 13		

## FEATURE

- Power as high as 150W + 150W (8Ω/4Ω, 20Hz ~ 20kHz) suitable for the digital audio age.
- Technics original circuit — new class A system that has eliminated both switching and crossover distortions.
- Computer drive circuit that has eliminated transient crossover distortion in playback of music.
- Linear feedback circuit that has completely eliminated theoretical value distortion.
- Power linear circuit that does not allow distortion caused by change in speaker impedance.
- Dual-line speaker terminals that allow the comparison of sounds by one-push operation.
- Dual-line input terminals DC-Normal.

## SAFETY PRECAUTION

1. Before servicing, unplug the power cord to prevent an electric shock.
2. When replacing parts, use only manufacturer's recommended components for safety.
3. Check the condition of the power cord. Replace if wear or damage is evident.
4. After servicing, be sure to restore the lead dress, insulation barriers, insulation papers, shields, etc.
5. Before returning the serviced equipment to the customer, be sure to make the following insulation resistance test to prevent the customer from being exposed to a shock hazard.

### INSULATION RESISTANCE TEST

1. Unplug the power cord and short the two prongs of the plug with a jumper wire.
2. Turn on the power switch.
3. Measure the resistance value with ohmmeter between the jumpered AC plug and each exposed metal cabinet part, such as screwheads antenna, control shafts, handle brackets, etc. Equipment with antenna terminals should read between 3MΩ and 5.2MΩ to all exposed parts. (Fig. A) Equipment without antenna terminals should read approximately infinity to all exposed parts. (Fig. B)

**Note:** Some exposed parts may be isolated from the chassis by design. These will read infinity.

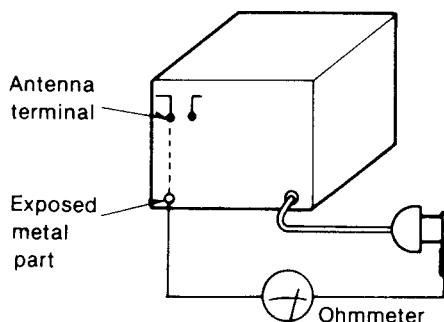

(Fig. A)

Resistance = 3MΩ — 5.2MΩ

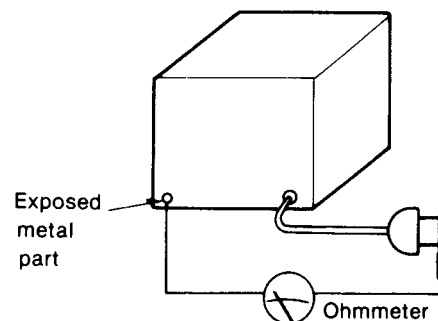

(Fig. B)

Resistance = Approx ∞

4. If the measurement is outside the specified limits, there is a possibility of a shock hazard. The equipment should be repaired and rechecked before it is returned to the customer.

## LOCATION OF CONTROLS

### • Front panel

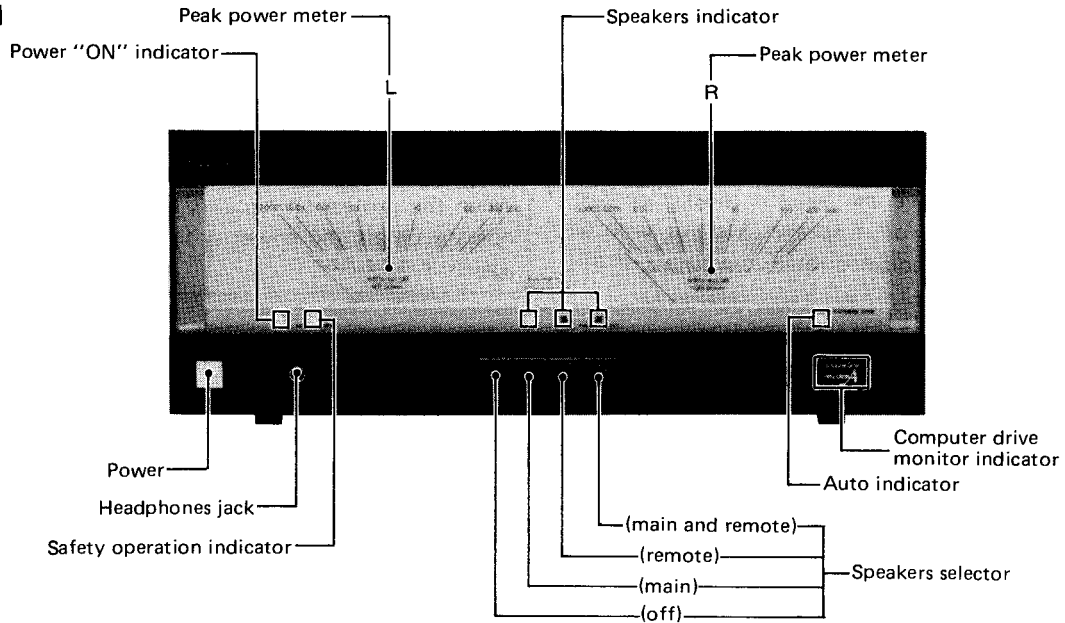

### • Rear panel

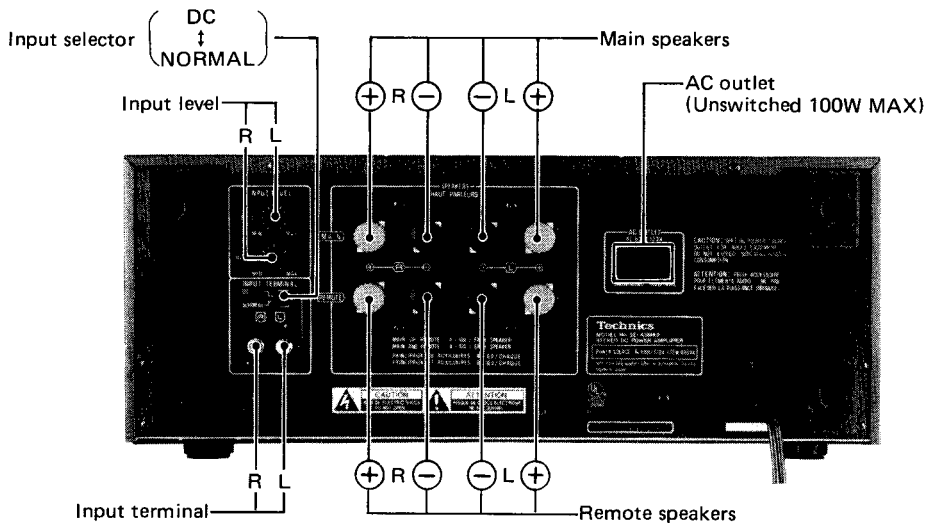

### • Top view

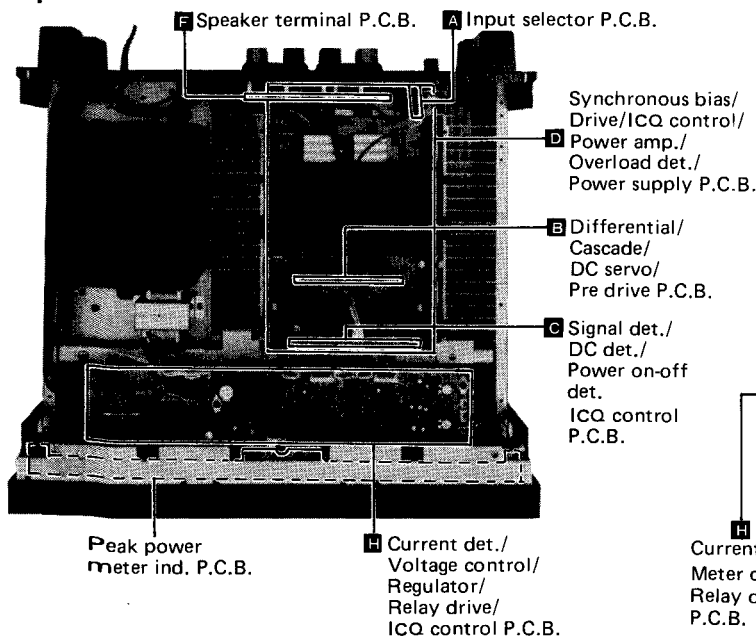

### • Bottom view

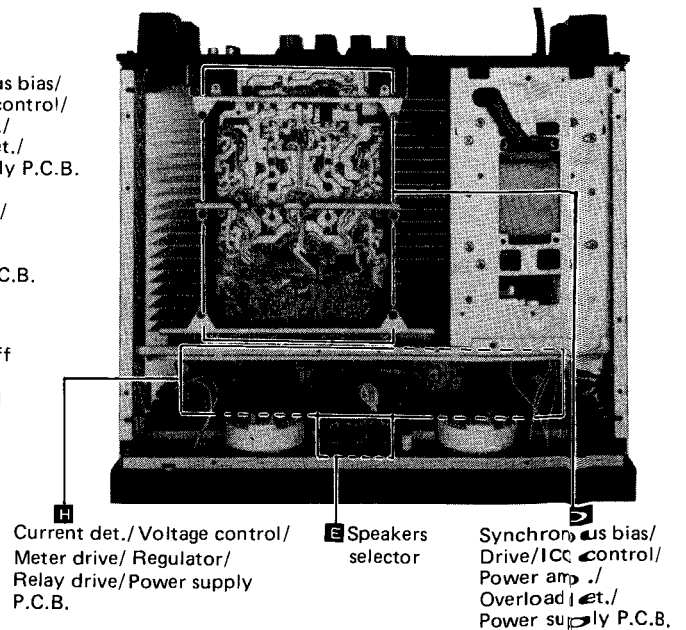

• Phono input capacitance is about 150pF.

## PROTECTION CIRCUITRY

The protection circuitry may have operated if either of the following conditions is noticed:

- No sound is heard when the power is turned on.
- Sound stops during a performance.

The function of this circuitry is to prevent circuitry damage if, for example, the positive and negative speaker connection wires are "shorted", or if speaker systems with an impedance less than the indicated rated impedance of this unit are used.

If this occurs, follow the procedure outlines below:

1. Turn off the power.
2. Determine the cause of the problem and correct it.
3. Turn on the power once again after one minute.

### Note

When the protection circuitry functions, the unit will not operate unless the power is first turned off and then on again.

## BEFORE REPAIR AND ADJUSTMENT

1. Turn off the power supply and short-circuit of power supply capacitors (C401 ~ C404, 8200 $\mu$ F) at resistance (about 10 $\Omega$ , 5W) in order to discharge the charged voltage. Do not short between C401 ~ C404 by screwdriver. It may damage the component.
2. Before turning on the power supply after completion of repair, slowly apply the primary voltage by using a power supply voltage controller to make sure that the consumed current at 120V, 60Hz in no-signal mode is 360mA ~ 820mA.

## DISASSEMBLY INSTRUCTIONS

### How to remove the cabinet

1. Remove the 10 setscrews (Fig. 1: ① ~ ⑩) of the cabinet.
2. Remove the cabinet in the direction of the arrow A in Fig. 1.

### How to remove the front panel

1. Remove the 4 setscrews (Fig. 1: ⑪ ~ ⑭) of the front panel.
2. Remove the front panel in the direction of the arrow B in Fig. 1.

### How to remove the bottom board

1. Remove the 9 setscrews (Fig. 2: ⑮ ~ ⑳) of the bottom board.

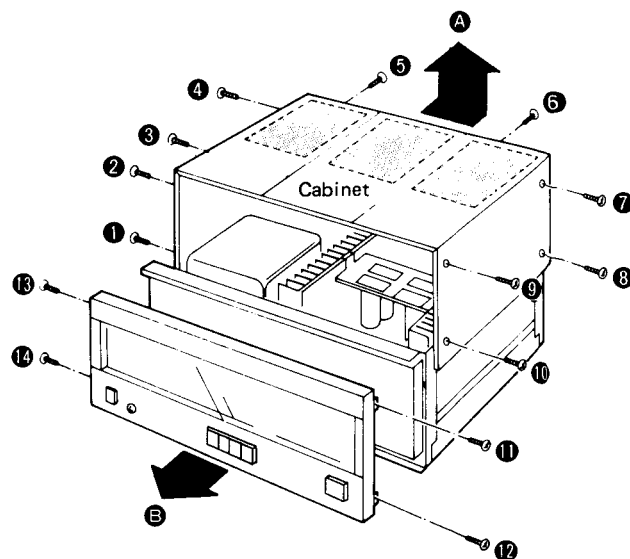

[Fig. 1]

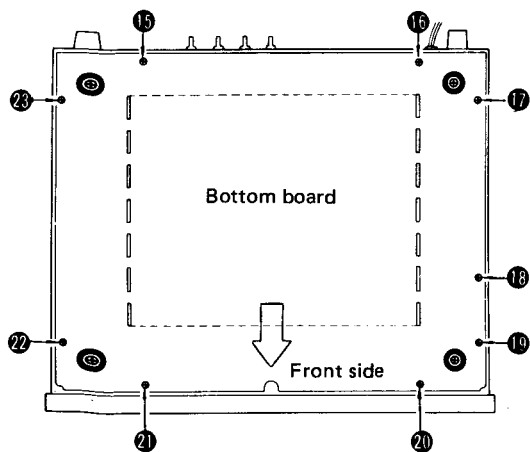

[Fig. 2]

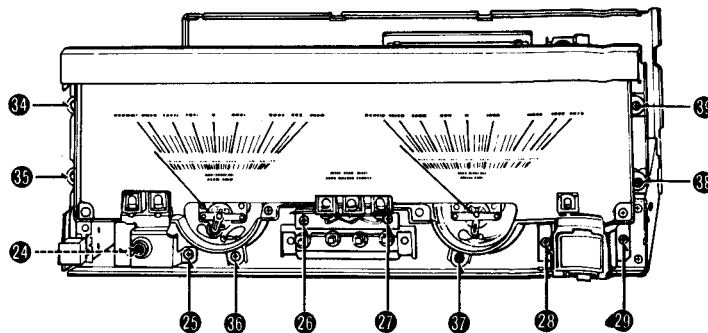

[Fig. 3]

## • How to remove the peak power meter

1. Remove the cabinet and front panel.
2. Remove the 6 setscrews (Fig. 3: 24 ~ 29 ), and then detach the headphones jack, speakers indicator and computer drive indicator bracket from the chassis.
3. Remove the 2 setscrews (Fig. 4: 30 , 31 ) and then detach the meter cover.
4. Remove the 2 setscrews (Fig. 4: 32 , 33 ) of the detach the meter lamp P.C.B.
5. Remove the 6 setscrews (Fig. 3: 34 ~ 39 ) of the peak power meter.
6. Remove the 1 setscrew (Fig. 5: 40 ) and then detach the peak power meter.

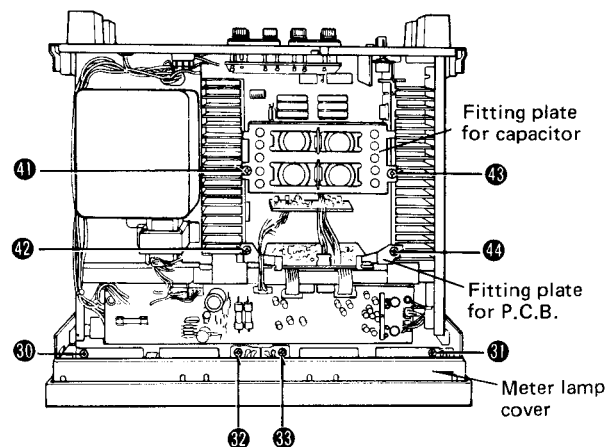

[ Fig. 4 ]

## • How to remove the power transistor

1. Remove the cabinet and bottom board.
2. Remove the 4 setscrews (Fig. 4: 41 ~ 44 ) and the detach the fitting plate.
3. Unsolder of power transistor. (R or L channel) [Fig. 6]
4. Remove the 3 setscrews (Fig. 6: 45 ~ 47 or 48 ~ 50 ) of the heat sink.
5. Remove the heat sink and power transistor.
6. When fitting it, apply silicone compound (**SZZOL15**) to both sides of mica plate. Also apply silicone compound (**SZZOL15**) to the heads of temperature compensation/ bias control transistors (**Q337, 338**) and thermistor (**TH501**), then fit them to the heat sink with the retaining plate.

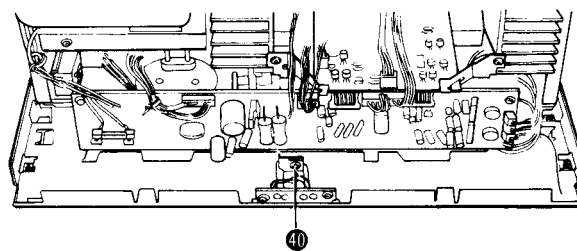

[ Fig. 5 ]

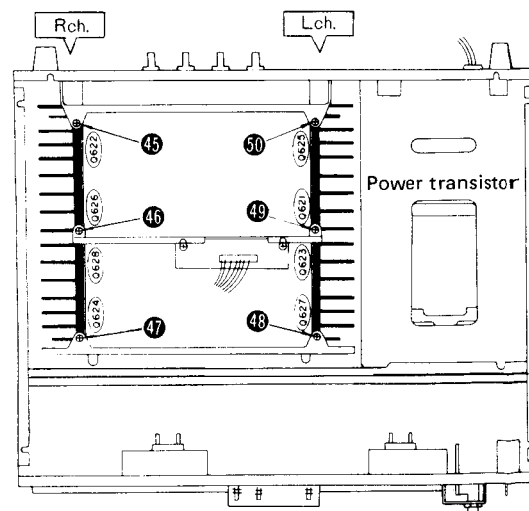

[ Fig. 6 ]

## MEASUREMENTS AND ADJUSTMENTS

### 1. Idling (ICQ) Adjustment (after repairing the main amp.) [Fig. 7]

- (1) After the repair, set the sound volume to maximal before turning on the power switch, and connect nothing to the speaker terminals.
- (2) Completely turn ICQ control (VR301, VR302) counter-clockwise.
- (3) Increase the voltage applied to the amplifier gradually from 0V by means of a power supply voltage controller, and make sure of the value in the Figure on page 4 before starting the adjustment.
- (4) Connect the DC electronic voltmeter to **TP301** (+) and **TP303** (-) (L ch) or **TP302** (+) and **TP304** (-) (R ch).
- (5) Adjust VR301 (L ch) or VR302 (R ch) so that the voltage is 4mV about 15 sec. after power switch "on".

In this set, ICQ is controlled by microcomputer, and ICQ a little more than the normal level is applied by "PREHEAT" for about 15 sec. after power ON. After that, the output level and transistor temperature are detected by "AUTO", thereby automatically controlling ICQ.

### 2. Peak Power Meter Level Adjustment (after repairing the meter amp circuit or replacing the peak power meter.)

- (1) Set the input level adjustment to the maximal position.
- (2) Connect a dummy resistor of  $8\Omega$  or a speaker of  $8\Omega$  impedance and AC voltmeter to the speaker terminal.
- (3) Apply 1kHz sine wave to the AUX/CD/VIDEO terminal and adjust the input so that the output to the speaker terminal is 28.3V.
- (4) Adjust both channels of VR101 (L ch) and VR102 (R ch) so that the meter indicating is 100W.

#### • Adjustment point

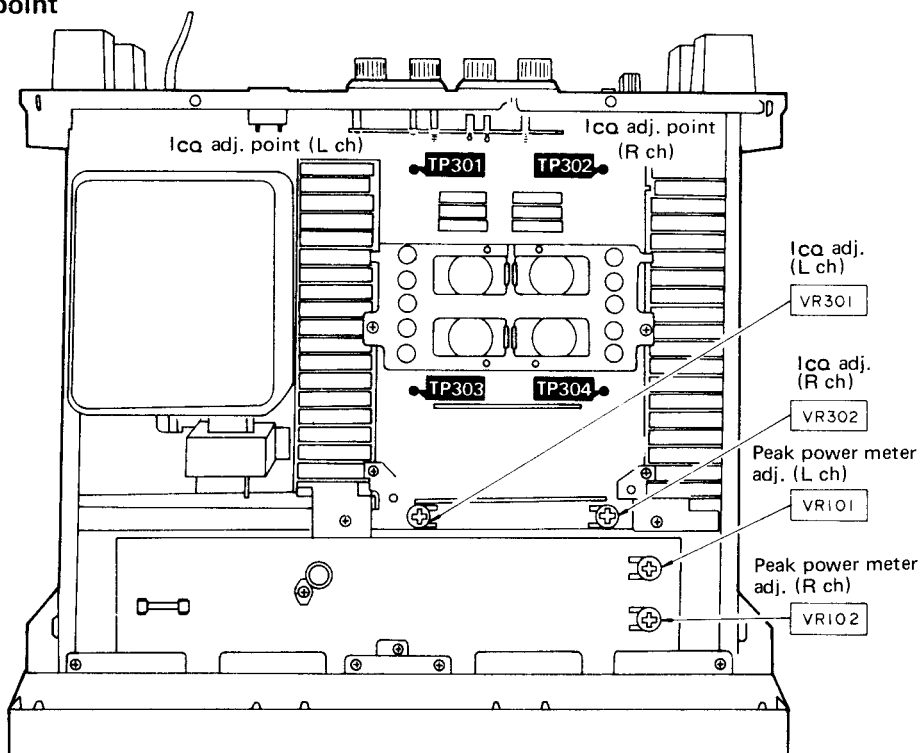

### 3. Check of Muting Circuit During Power "on"—"off" Operation.

- (1) Connect  $8\Omega$  load and AC voltmeter to the speaker terminal.
- (2) Set the input level adjustment to the maximal position.
- (3) Apply 1kHz sine wave, 0.5V to the speaker terminal.
- (4) Make sure that output is delivered about 3 ~ 5 sec. after turning the power switch "on".
- (5) Output should immediately be gone when power switch is turned "off".

### 4. Check of DC Detection Circuit

- (1) Set the input level adjustment to the maximal position.
- (2) Apply DC voltage +1V (to L ch), -1V (to R ch) to the DC input terminal.
- (3) Make sure
  - relay is off.
  - "auto" indicator "on" goes out.
  - "safety operation" indicator blinks.

### 5. Check of Overload Detection and Protection Circuit

- (1) Connect  $8\Omega$  (resistor or speaker) and AC voltmeter to the main speaker terminal.
- (2) Main speaker selector is "on" position.
- (3) Connect  $0.33\Omega$  (5W) resistor to the remote speaker terminal.
- (4) Apply output signal of about 5V at 1kHz to input terminal.
- (5) Make sure that no output is delivered when remote speaker switch is set to "on".

When the protection circuitry functions, the unit will not operate unless the power is first turned off and then on again.

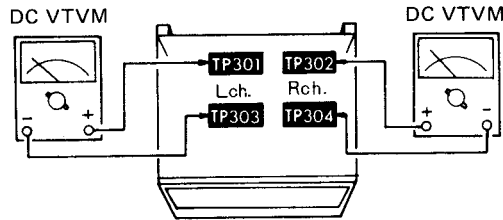

[Fig. 7] Idling (ICQ) Adjustment

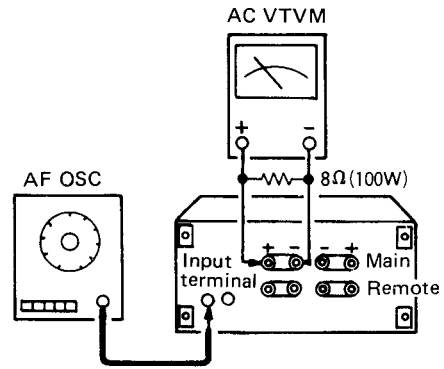

[Fig. 8] Peak power meter adjustment

## RESISTORS & CAPACITORS

- Notes:**
- Part numbers are indicated on most mechanical parts. Please use this part number for parts orders.
  - Important safety notice:  
Components identified by  $\Delta$  mark have special characteristics important for safety. When replacing any of these components use only manufacturer's specified parts.
  - The "S" mark is service standard parts and may differ from production parts.
  - The unit of resistance is  $\Omega$  (ohm),  
K = 1000 $\Omega$ , M = 1000k $\Omega$ .
  - The unit of capacitance is  $\mu$ F (microfarad).  
P = 10<sup>-6</sup>  $\mu$ F
  - Bracketed indications in Ref. No. columns specify the area. Parts without these indications can be used for all areas.

Resistor Type	Wattage	Tolerance
ERD : Carbon	10 : 1/8W	J : $\pm$ 5%
ERG : Metal Oxide	25 : 1/4W	G : $\pm$ 5%
ERO : Metal Film	2 : 2W	
ERF : Non-flammable	S1 : 1/2W	
	3 : 3W	

ERD10TLJ □□□ → Chip type carbon

Capacitor Type	Voltage		Tolerance
	ECEA Type	Other	
ECEA : Electrolytic	0J : 6.3V	1H : 50V	D : $\pm$ 0.5pF
ECCD : Ceramic	1A : 10V	KC : 400V AC	K : $\pm$ 10%
ECKD : Ceramic	1C : 16V	2H : 500V	Z : +80%, -20%
ECQM : Polyester	1E : 25V		P : +100%, -0%
ECET : Electrolytic	1H : 50V		
ECEA...N : Non Polar Electrolytic	50 : 50V		
	25 : 25V		
	45 : 45V		
	2A : 100V		

### RESISTORS

Ref. No.	Part No.	Value	Ref. No.	Part No.	Value	Ref. No.	Part No.	Value	Ref. No.	Part No.	Value
R21, 22	ERD10TLJ223U	22K	R301, 302	ERD25FJ221	220	R363, 364	ERD25FJ271	270	R515	ERDS1FJ391	390
R23, 24	ERD10TLJ223U	22K	R305, 306	ERD25FJ272	2.7K	R365, 366	ERD25FJ2R2	2.2	R516	ERDS1FJ331	330
R25, 26	ERD10TLJ333U	33K	R307, 308	ERD25FJ392	3.9K	R367, 368	ERD25FJ2R2	2.2	R517	ERDS1FJ391	390
R27, 28	ERD10TLJ123U	12K	R309, 310	ERD25FJ392	3.9K	R369, 370	ERD25FJ2R2	2.2	R518	ERD25FJ181	180
R29	ERD25FJ472	4.7K	R311, 312	ERD25TJ393	39K	R371, 372	ERD25FJ2R2	2.2	R519	ERD25FJ100	10
R30, 31	ERD10TLJ103U	10K	R313, 314	ERD25FJ103	10K	R373, 374	ERF3RKR33	0.33	R520	ERD25TJ683	68K
R32	ERD25FJ103	10K	R315, 316	ERD25FJ330	33	R375, 376	ERF3RKR33	0.33	R601, 602	ERD25FJ151	150
R33	ERD10TLJ102U	1K	R317, 318	ERD25TJ393	39K	R377, 378	ERF3RKR33	0.33	R603	ERD25FJ222	2.2K
R34, 35	ERD10TLJ104U	100K	R319, 320	ERD25FJ103	10K	R379, 380	ERF3RKR33	0.33	R604	ERD25FJ151	150
R36	ERD10TLJ333U	33K	R321, 322	ERD25FJ561	560	R381, 382	ERD25TJ224	220K	R605	ERD25TJ333	33K
R37, 38	ERD25FJ822	8.2K	R323, 324	ERD25FJ471	470	R383, 384	ERD25TJ224	220K	R606	ERD25TJ223	22K
R39	ERD25TJ394	390K	R325, 326	ERD25FJ151	150	R385, 386	ERD25FJ3R3	3.3	R607, 608	ERG3ANJ331	330
R40	ERD25TJ223	22K	R327, 328	ERD25FJ151	150	R387, 388	ERD25FJ3R3	3.3	R609	ERD25FJ181	180
R41, 42	ERD10TLJ223U	22K	R329, 330	ERD25FJ102	1K	R389, 390	ERD25FJ100	10	R701, 702	ERD25FJ331	330
R43	ERD10TLJ223U	22K	R331, 332	ERD25FJ821	820	R391, 392	ERG2ANJ100	10	R703, 704	ERD25FJ681	680
R44, 45	ERD25TJ223	22K	R333, 334	ERD25FJ102	1K	R393, 394	ERD25FJ100	10	R705, 706	ERD25TJ124	120K
R46	ERD10TLJ392U	3.9K	R335, 336	ERD25FJ102	1K	R395, 396	ERD25FJ561	560	R707, 708	ERD25FJ562	5.6K
R47	ERD25FJ472	4.7K	R337, 338	ERD25FJ681	680	R397, 398	ERD25FJ222	2.2K	R709, 710	ERD25TJ333	33K
R48	ERD10TLJ392U	3.9K	R339, 340	ERD25FJ681	680	R401, 402	ERD2FCG5R6	5.6	R711, 712	ERD25TJ333	33K
R49	ERD10TLJ153U	15K	R341, 342	ERD25FJ101	100	R403, 404	ERD2FCG5R6	5.6	R713, 714	ERD25TJ333	33K
R50	ERD10TLJ103U	10K	R343, 344	ERD25FJ101	100	R405, 406	ERD25FJ472	4.7K	R715, 716	ERDS1FJ102	1K
R101, 102	ERO25CKF1962	19.6K	R345, 346	ERD25FJ101	100	R501, 502	ERD25FJ222	2.2K	R717, 718	ERDS1FJ102	1K
R103, 104	ERD25TJ824	820K	R347, 348	ERD25FJ101	100	R503, 504	ERD25FJ681	680	R801, 802	ERD25FJ103	10K
R105, 106	ERD25TJ104	100K	R349, 350	ERD25FJ102	1K	R505, 506	ERD25FJ331	330	R803, 804	ERD25TJ224	220K
R107, 108	ERD25FJ102	1K	R351, 352	ERD25FJ102	1K	R507, 508	ERD25TJ183	18K	R805, 806	ERD25TJ224	220K
R109, 110	ERD25FJ471	470	R353, 354	ERD25TJ333	33K	R509	ERD25TJ183	18K	R851, 852	ERD25TJ393	39K
R111, 112	ERD25FJ221	220	R355, 356	ERD25TJ104	100K	R511	ERD25TJ104	100K	R853, 854	ERD25FJ222	1.2K
R113, 114	ERD25FJ222	2.2K	R357, 358	ERD25TJ104	100K	R512	ERD25TJ224	220K			
R201, 202	ERD25FJ222	2.2K	R359, 360	ERD25TJ223	22K	R513	ERD25TJ223	22K			
R203, 204	ERD25TJ224	220K	R361, 362	ERD25TJ823	82K	R514	ERD25FJ472	4.7K			

# SE-A5MK2

## PRINTED CIRCUIT BOARDS PEAK POWER METER P.C.B.

### • CAPACITORS

Ref. No.	Part No.	Value
C21, 22	ECEA1EU3R3	3.3
C23	ECEA1CU100	10
C24	ECEA1CU101	100
C25	ECEA1HUR47	0.47
C26	Ⓢ ECKD1H121K	120P
C27	ECEA0JU101	100
C28	Ⓢ ECKD1H223ZF	0.022
C101, 102	△ ECEA1EN3R3S	3.3
C103, 104	ECEA1HUR47	0.47
C105, 106	ECEA1HUR47	0.47
C107, 108	ECEA1CU470	47
C201, 202	△ ECEA1HN2R2S	2.2
C203, 204	Ⓢ ECCD1H181K	180P
C301, 302	Ⓢ ECCD1H101K	100P
C303, 304	Ⓢ ECKD1H681KB	680P
C307, 308	Ⓢ ECCD2H070D	7P
C309, 310	Ⓢ ECCD2H070D	7P
C311, 312	Ⓢ ECCD2H270K	27P
C313, 314	Ⓢ ECCD2H270K	27P
C315, 316	ECEA1HU330	33
C317, 318	ECEA2AU010	1
C321, 322	ECEA1CU100	10
C323, 324	ECEA1EU4R7	4.7
C325, 326	Ⓢ △ ECEA25N4R7	4.7
C327, 378	Ⓢ ECCD1H120KC	12P
C331, 332	Ⓢ ECKD1H681KB	680P
C333, 334	Ⓢ ECKD1H681KB	680P
C339, 340	ECQM1H473KV	0.047
C401, 402	ECET1KV822Z	8200
C403, 404	ECET1KV822Z	8200
C405	ECEA1VU102	1000
C406	ECEA1VU471	470
C407, 408	ECEA1EU330	33
C409	ECEA1EU3R3	3.3
C410	Ⓢ ECKD1H103ZF	0.01
C501	ECEA1HU010	1
C502	ECEA0JU470	47
C503	Ⓢ ECKD1H103ZF	0.01
C504	ECEA1HU010	1
C701, 702	ECEA1CU100	10
C703, 704	Ⓢ ECKD1H103ZF	0.01
C801, 802	Ⓢ ECCD1H101K	100P
C803, 804	Ⓢ ECKD1H221KB	220P
C805, 806	Ⓢ ECKD1H221KB	220P
C1001	△ ECKDKC103PF2	0.01

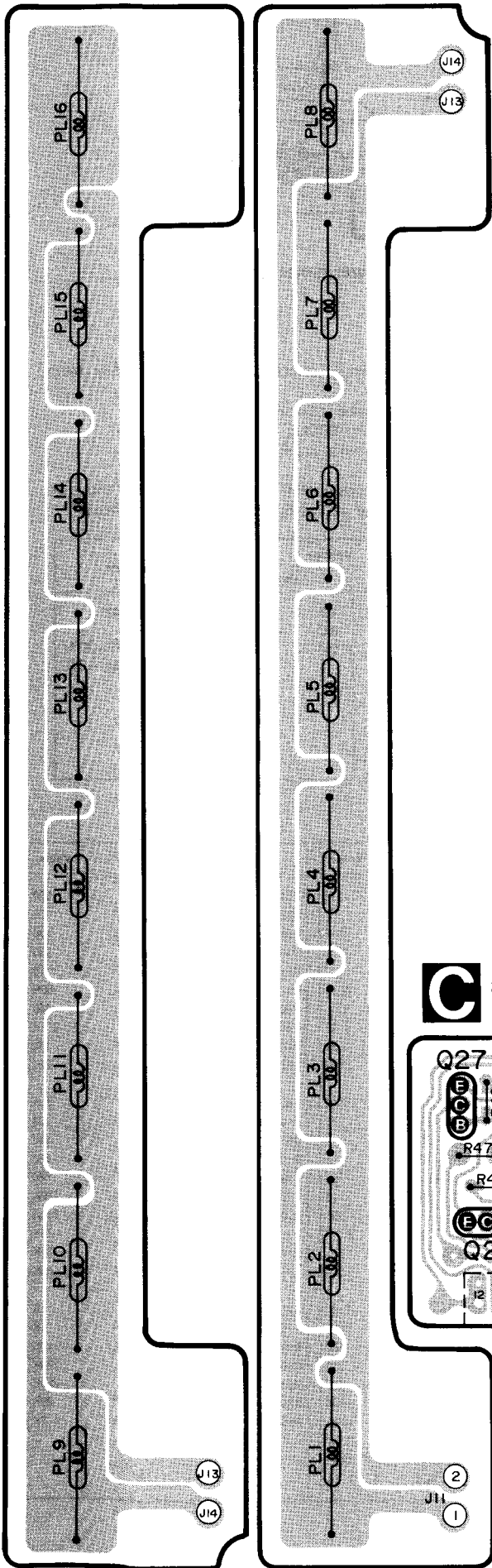

### C SIGNAL DET./DC DET./POWER ON-OFF DET./ I<sub>cc</sub> CONTROL P.C.B.

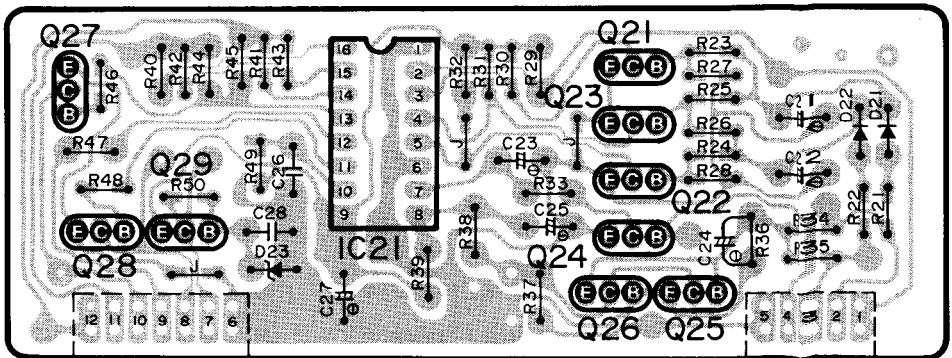

### G HEADPHONES TERMINAL P.C.B.

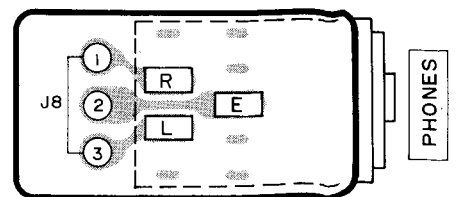



**H** CURRENT DET./METER DRIVE/REGULATOR/RELAY DRIVE/POWER SUPPLY P.C.B.

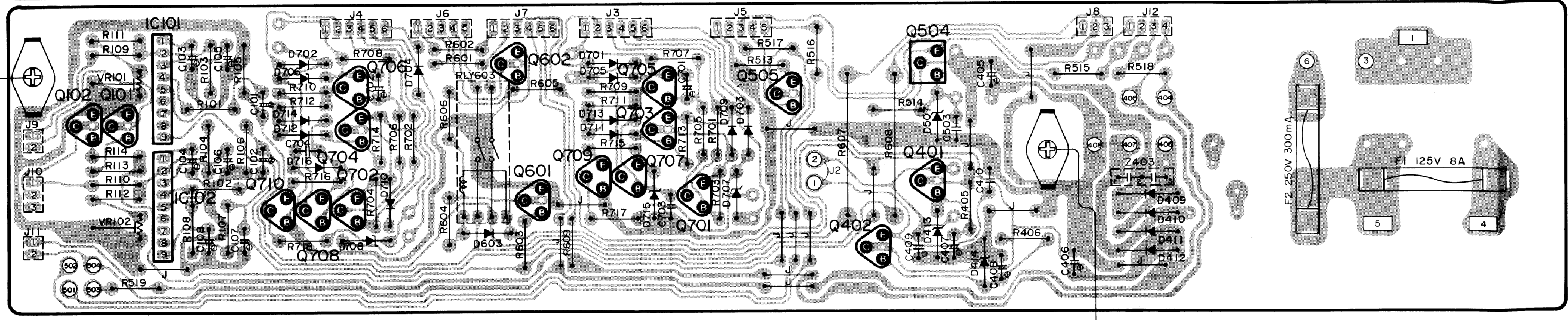

**D** SYNCHRONOUS BIAS/IcQ CONTROL/DRIVE-POWER AMP./OVER LOAD DET./POWER SUPPLY P.C.B.

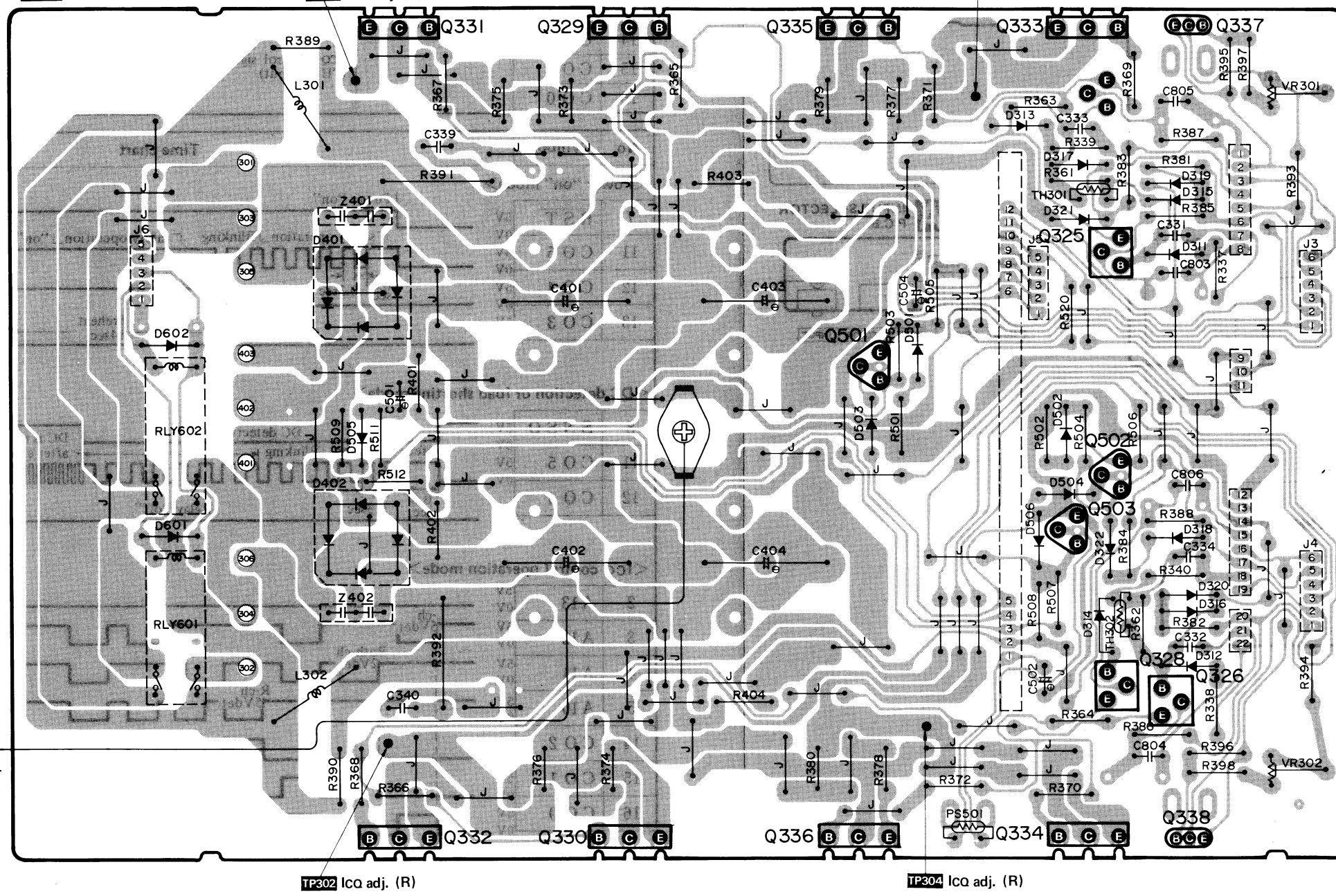

**B** DIFFERENTIAL AMP/CASCADE/DC SERVO/ PRE DRIVE AMP. P.C.B.

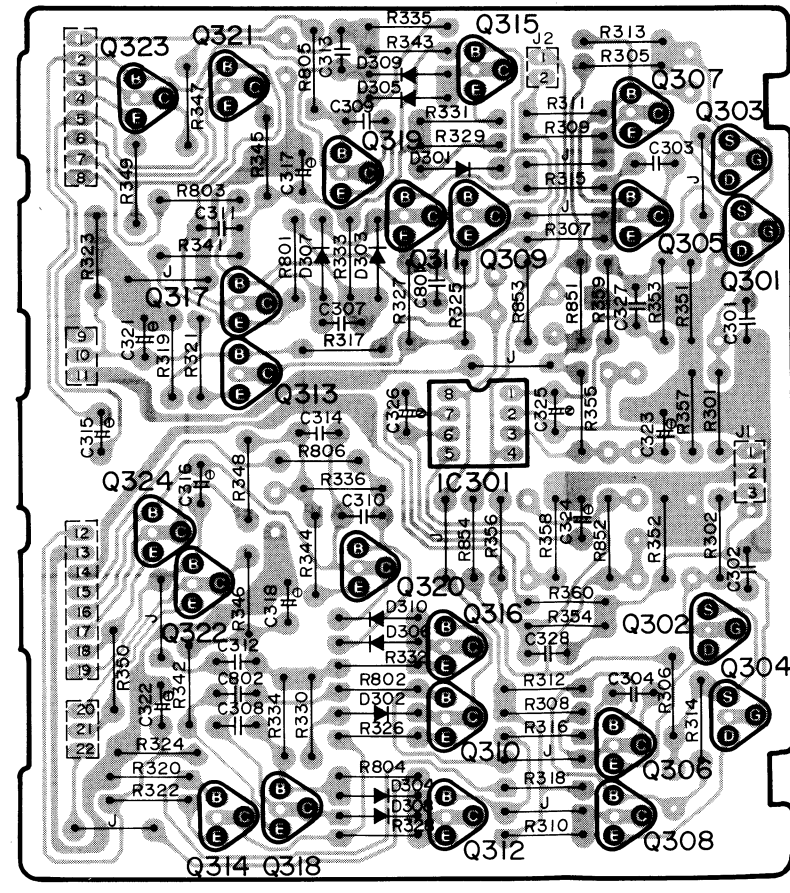



**CIRCUIT BOARDS AND WIRING CONNECTION DIAGRAM (Top View)**

**TERMINAL**

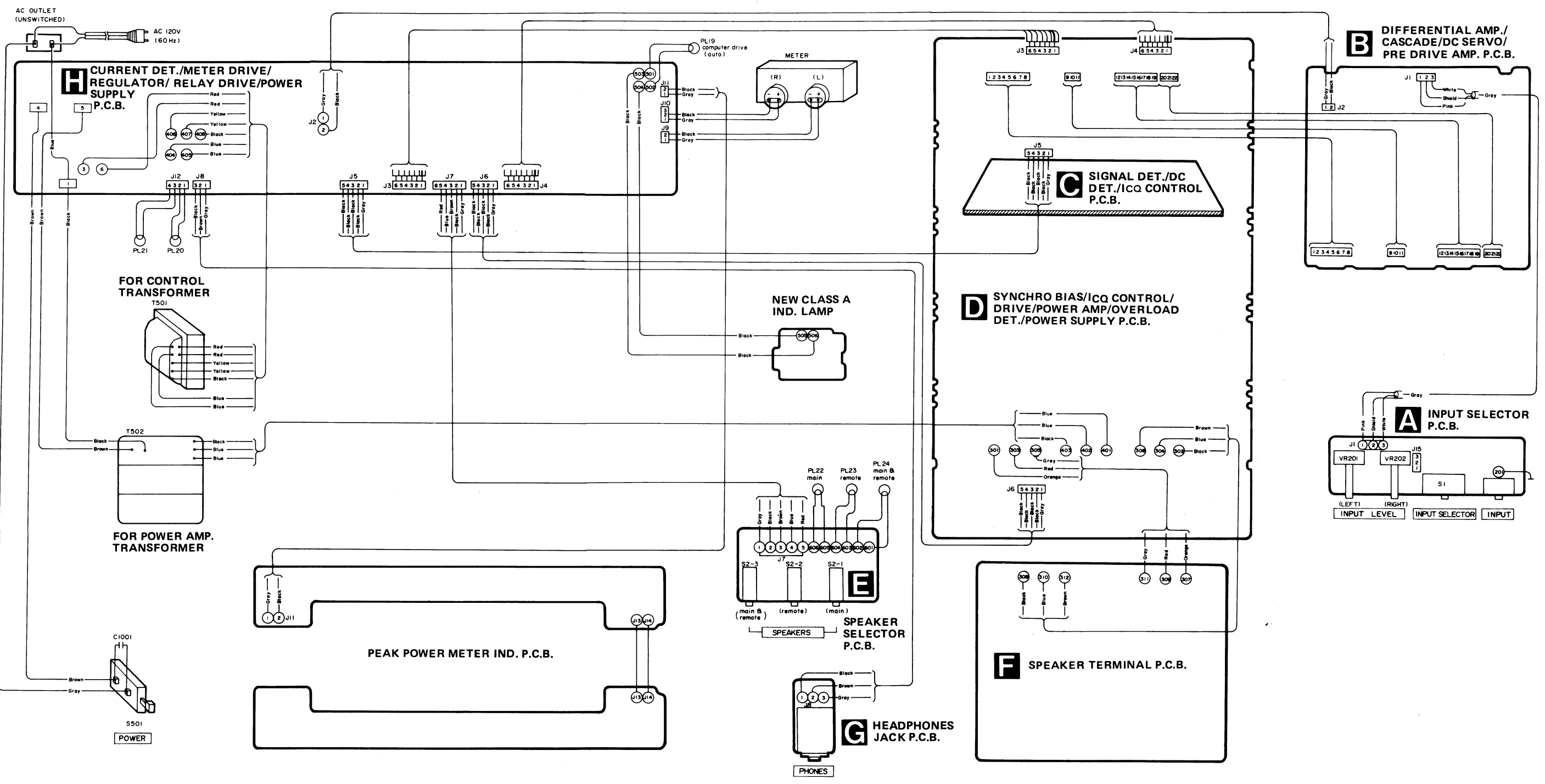

No.	Symbol
1	VSS
2	A13
3	A12
4	A11
5	A10
6	TST
7	RST
8	SNS
9	VDD
10	OSC
11	CO5
12	CO4
13	CO3
14	CO2
15	CO1
16	CO0

No.	Symbol
<b>&lt;Power "on"</b>	
7	RST
11	CO5
12	CO4
13	CO3

<b>&lt;DC detection</b>	
8	SNS
11	CO5
12	CO4

<b>&lt;IcQ control</b>	
2	A13
3	A12
4	A11
5	A10
14	CO2
15	CO1
16	CO0

MC-Service

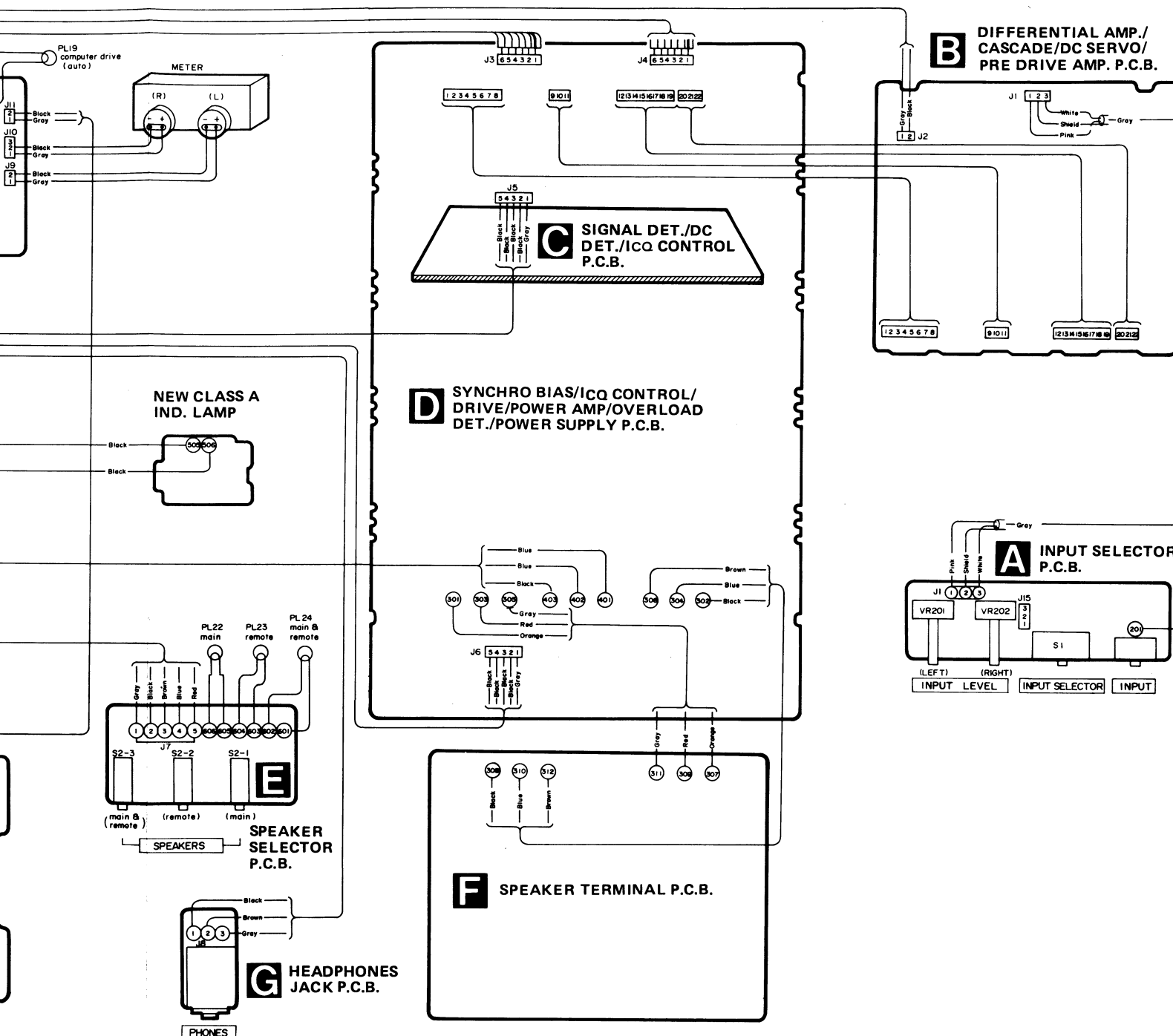

■ TERMINAL NAMES AND FUNCTION OF IcQ CONTROL (MN1404STE)

No.	Symbol	Name of block	Description of terminal
1	VSS	Power supply input terminal	Grounded. (0V)
2	A13	Input port A	Temperature detection circuit. When 60°C (140°F) sensor of power amplifier operates, "H" is put in causing the outputs of terminals 14 ~ 16 to go "H".
3	A12		When effective output 5V signal sensor of L-ch power amplifier operates, "L" is put in causing the output of terminal 14 to go "H".
4	A11		When effective output 2V signal sensors of both-ch power amplifiers operate, "L" is put in causing the output of terminal 15 to go "H".
5	A10		When effective output 5V signal sensor of R-ch power amplifier operates, "L" is put in causing the output of terminal 16 to go "H".
6	TST		Test input terminal
7	RST	Reset input terminal	All outputs are cleared or reset with input at "L". (It is connected to power supply circuit)
8	SNSO	Sensor input terminal	When overload detection circuit of power amplifier output operates, "H" is put in causing the output of terminal 12 to go "L".
9	VDD	Power supply input terminal	Apply 5V.
10	OSC	OSC input terminal	Clock signal (about 415kHz) can be obtained by internal oscillation circuit.
11	CO5	Output port C	When protection circuit operates, "H" and "L" outputs are repeated and "safety operation" indicator blinks.
12	CO4		Output relay and meter relay turn ON with "H" output.
13	CO3		Indicator "auto" lights up at "H".
14	CO2		IcQ control signal is emitted from A input port (temp. sensor, signal sensor). ("H" output)
15	CO1		
16	CO0		

No. Symbol Time chart

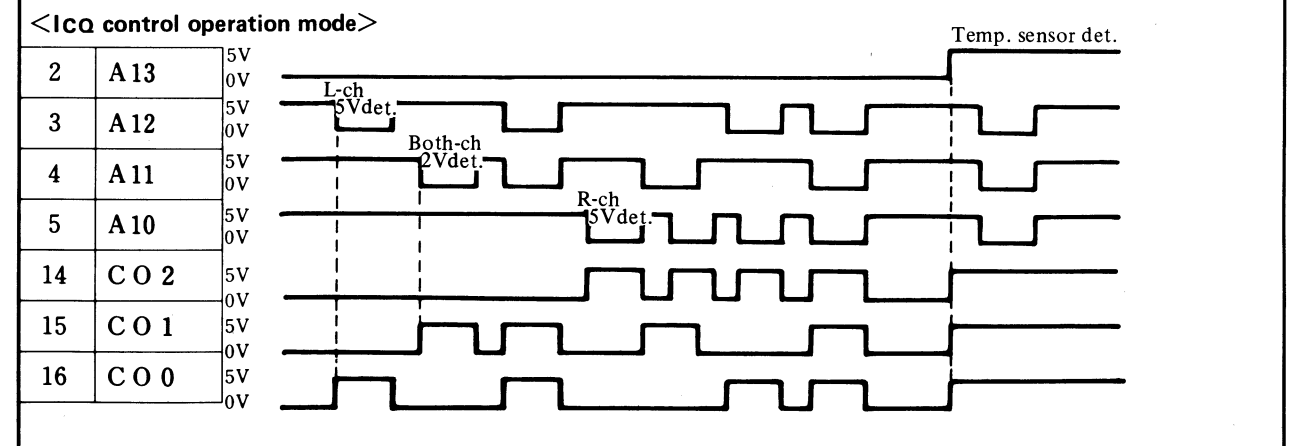
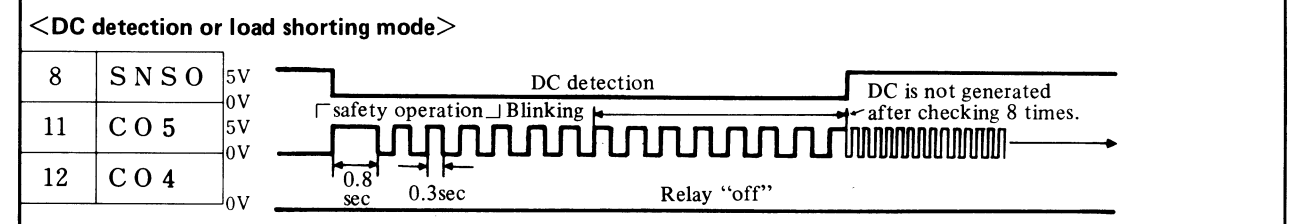
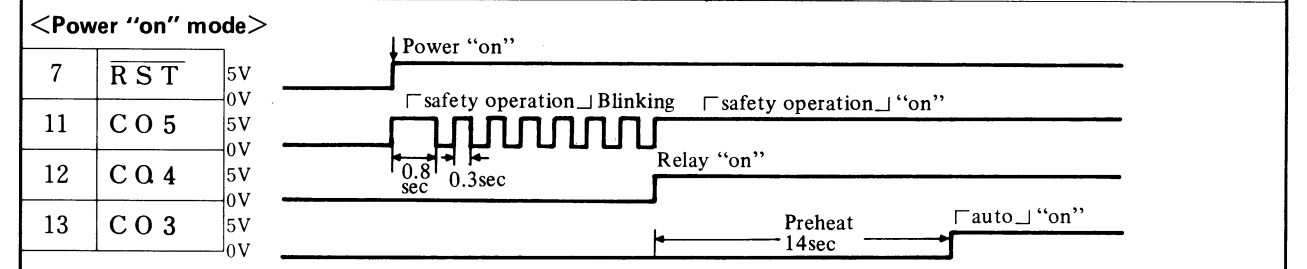

# SE-A5MK2

## BLOCK DIAGRAM

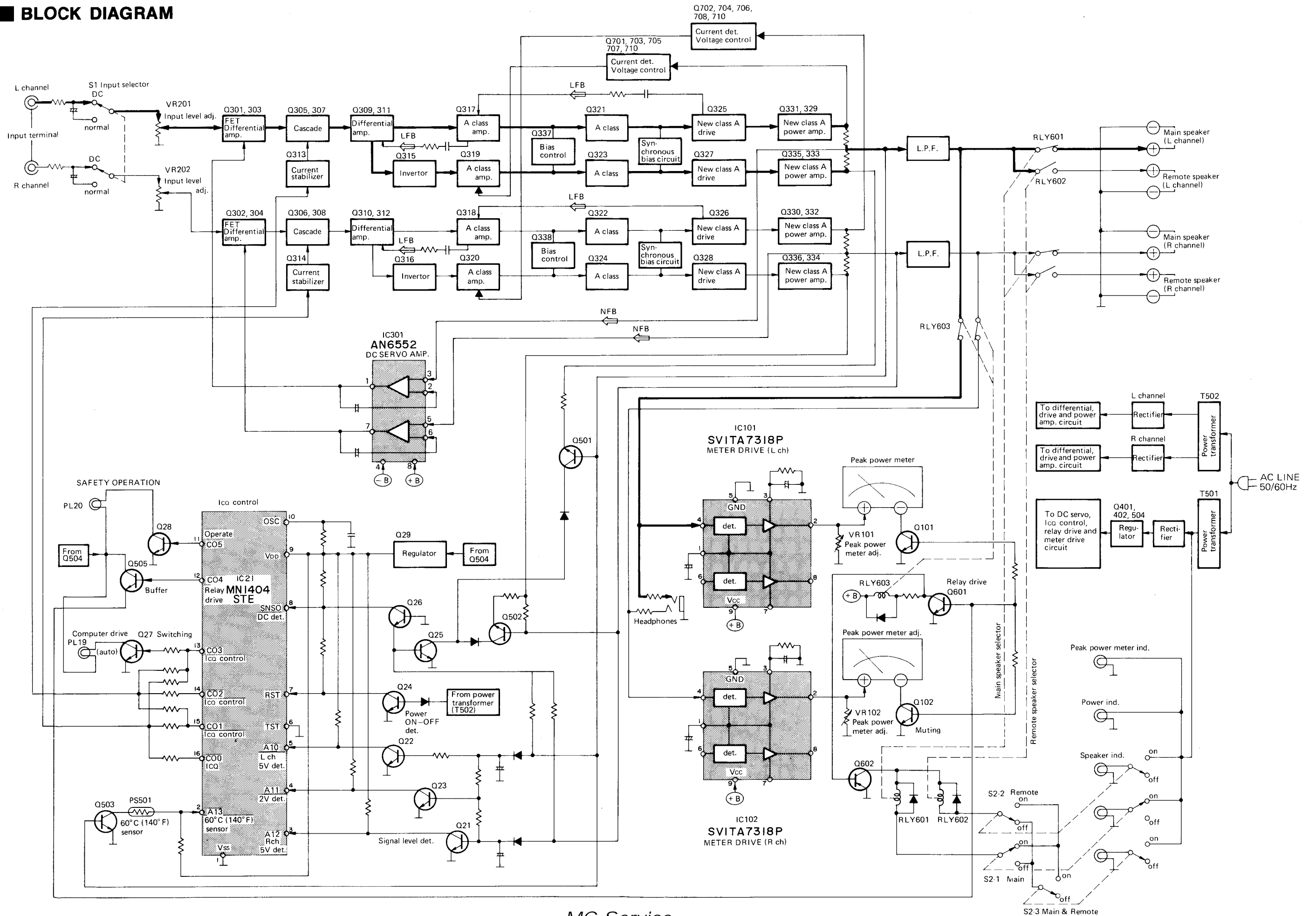

DESCRIPTION OF ICQ CONTROL CIRCUIT

Signal and temperature detection (See Fig. 9.)

1. Music signal of power amplifier is applied to IC21 terminal ③ (⑤) of D21 (D22) and Q21 (Q22). When the signal rectified by D21 (D22) and C21 (C22) exceeds about 5V, Q21 (Q22) turns "on" causing "L" input to be applied to IC21 terminal ③ (⑤). Also, when the signal is over 2V, Q23 turns "on" causing "L" put to be applied to IC21 terminal ④. As "L" is put into IC21 terminals ③ ~ ⑤, the outputs of terminals ⑭ ~ ⑯ go "H" to make ICQ control.
2. PS501 is the thermistor (positor) for heat sink temperature detection which detects the temperature [60°C (140°F)] of the heat sink. When the heat sink temperature becomes [60°C (140°F)], the resistance of PS501 increases causing "H" input to be applied to IC21 terminal ②. As "H" is put into IC21 terminal ②, the outputs of IC21 terminals ⑭ ~ ⑯ go "H" to make ICQ control.

Overload detection circuit (See Fig. 9.)

When speaker terminals are shorted, great current flows to R503 (R504) causing the base potential of Q501 (Q502) (overload detection circuit) to increase, then the base voltage of Q501 (Q502) rises and Q501 (Q502) turns "on". With Q501 (Q502) turned ON, both Q25 and Q26 turn "on" causing "L" input to be applied to IC21 terminal ⑧. Then, "L" output is applied to IC21 terminals ⑫ and ⑬. As terminal ⑫ goes "L", Q501, Q601 and Q602 turn "off" causing RLY601 ~ 603 to turn "off". When terminal ⑬ goes "L", Q27 turns "off" causing "auto" indicator to turn "off". Also, "H" and "L" outputs are delivered from terminal ⑪ at 0.1 sec. intervals, then the "safety operation" indicator blinks.

CURRENT DETECTION TYPE VOLTAGE CONTROL CIRCUIT

- ① With 4Ω speaker connected, great current flows to the power transistor, then voltage is generated between A - B, and Q701 turns "on" when the voltage exceeds V1. (Note 1)
- ② When Q701 turns "on", current flows to R707 and R705, causing Q705 to turn "on".
- ③ As (+B) voltage comes to the collector of Q705, each of Q703, Q707 and Q709 turns "on", and voltage is applied to D715, D705 and D707, then the collector voltage of pre-drive Q317 and Q319 is controlled to a degree 16V lower than (+B) voltage. Controlling the collector voltage of Q317 and Q319 is intended to control the great current of power transistor.
- ④ As Q703 is "on", even if the current of power transistor is then reduced, ③ is not reset allowing output control to continue when the voltage between A - B is higher than V2. (Note 2)
- ⑤ When the voltage between A - B is lower than V2 (Note 2) as the current of power transistor is reduced, then Q701 turns "off" and ③ is reset.

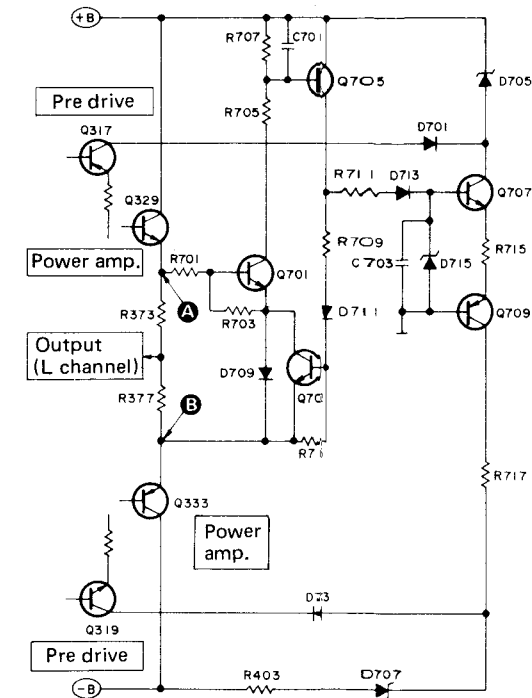

[Note 1]  $V1 = \frac{R1 + R2}{R2} \cdot Vbe + VF$

[Note 2]  $V2 = \frac{R1 + R2}{R2} \cdot Vbe + Vsat$

R1 : Resistance value of R701  
 R2 : Resistance value of R703  
 Vbe : Base - emitter voltage to turn Q701 "on"  
 VF : Forward voltage of Q709  
 Vsat : Collector - emitter saturation voltage of Q701

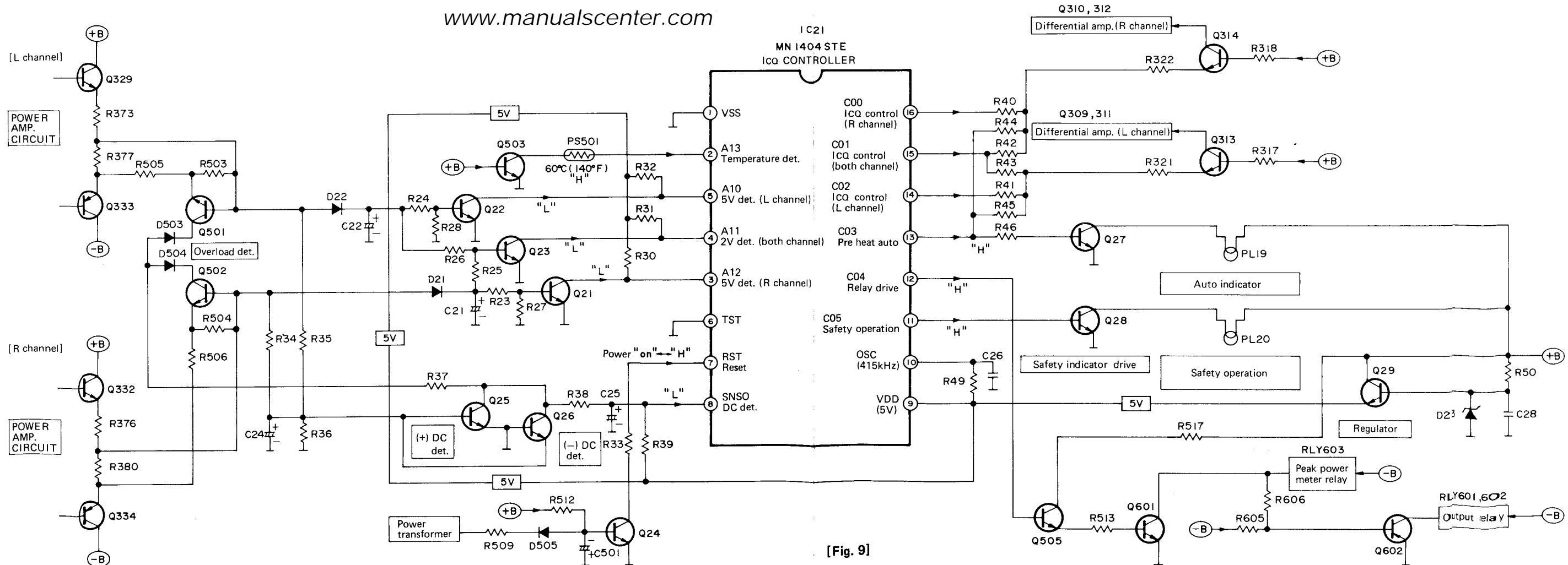

[Fig. 9]

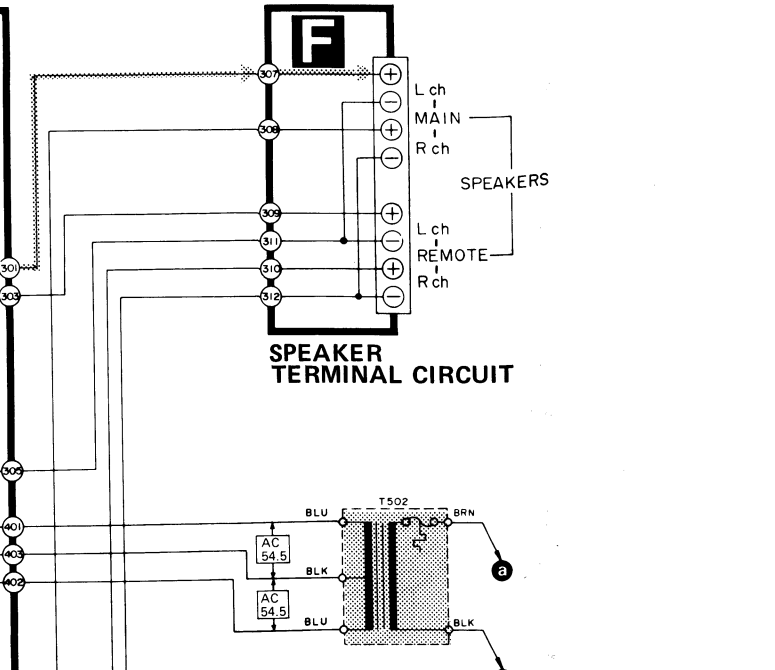
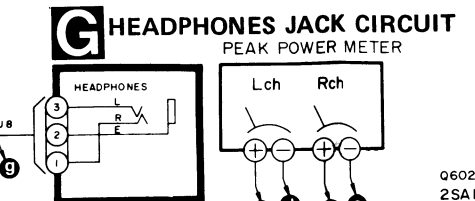
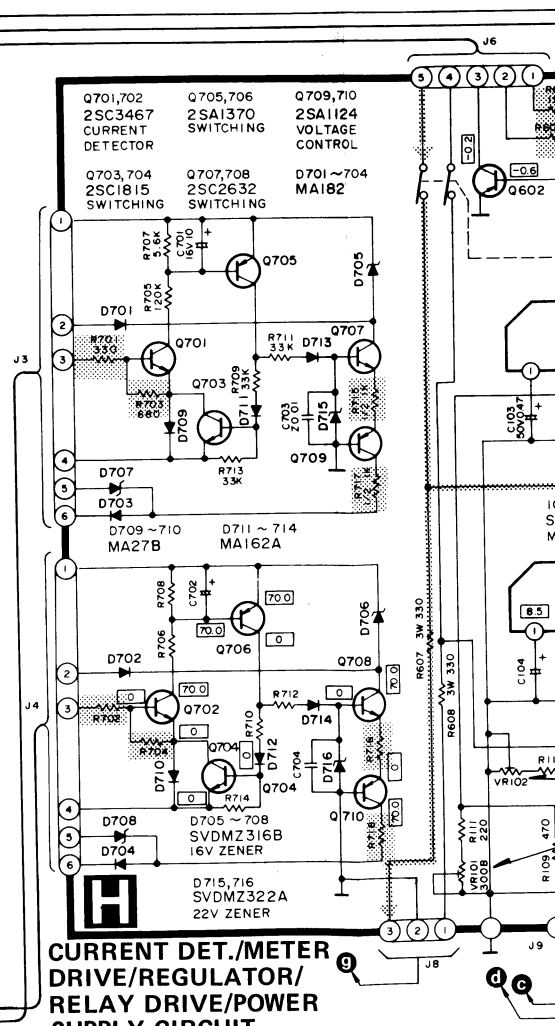
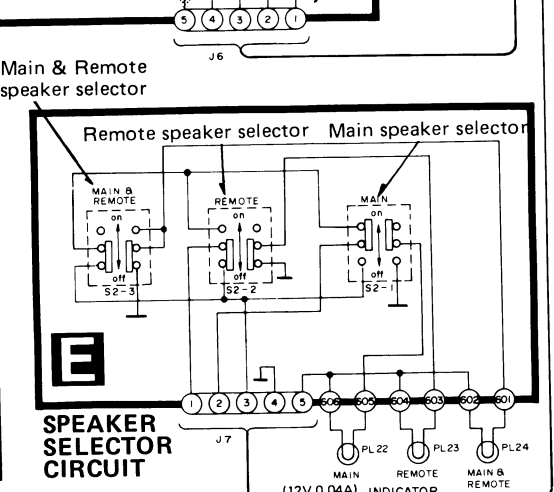
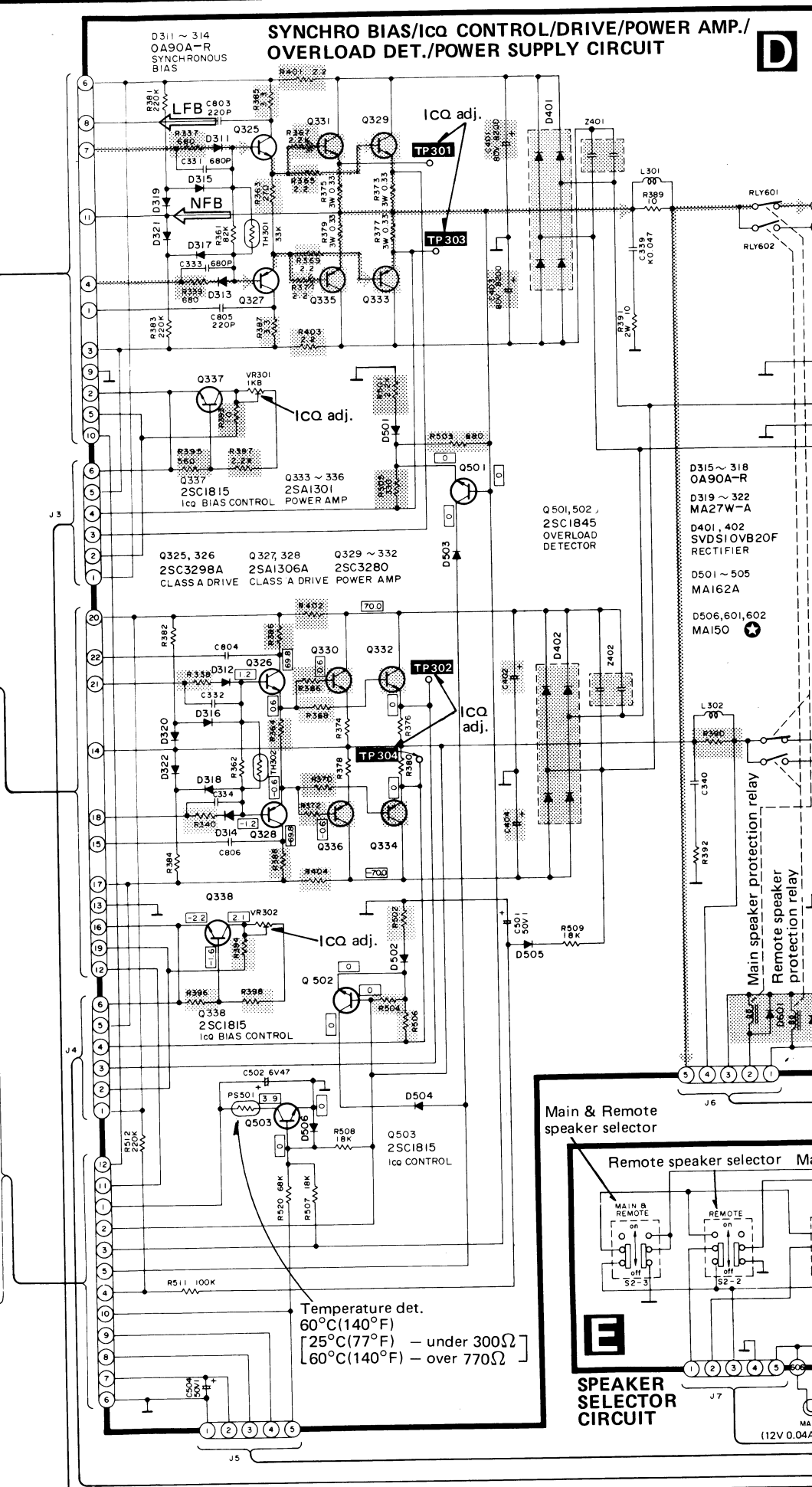
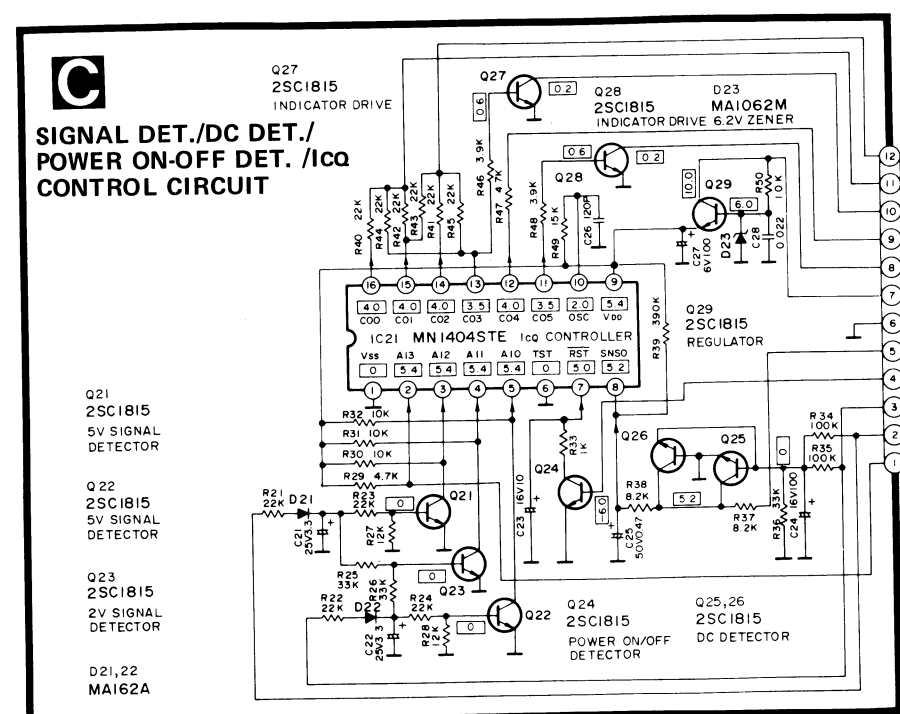
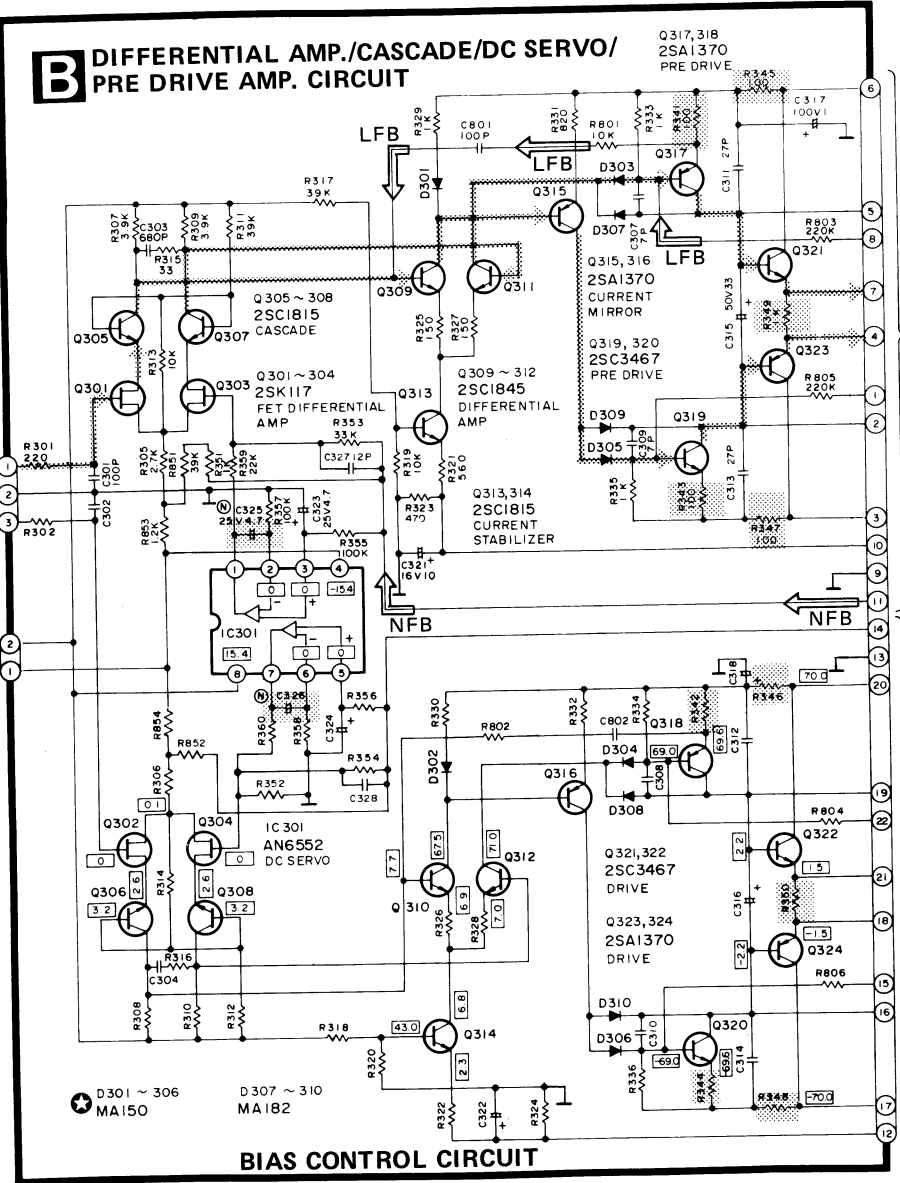
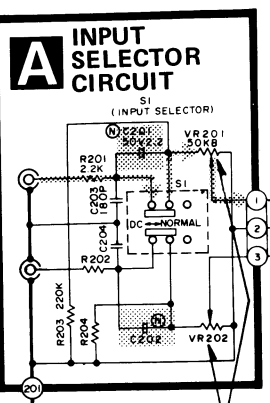

SCHEMATIC DIAGRAM

(This schematic diagram may be modified at any time with the development of new technology.)

- The part No. of transistors, IC and diodes mentioned in the schematic diagram stand for production part No. Regarding the Part No. with \* mark, the production part No. are different from the replacement part No. Therefore, when placing an order for replacement parts, please use the part No. in the replacement parts list.

Notes:

- 1. S1 : Input level selector switch in "DC" position. DC ↔ normal
2. S2-1 ~ S2-3 : Speaker selector switch in "main" position. S2-1: main, S2-2: remote, S2-3: main and remote
3. S501 : Power switch in "on" position.
4. Indicated voltage values are the standard values for the DC electronic circuit tester (high impedance) with the chassis taken as standard. Therefore, there may exist some errors in the voltage values, depending on the internal impedance of the DC circuit tester.
5. Phono signal lines of left channel.
6. Positive (+B) voltage lines or negative (-B) voltage lines.

IMPORTANT SAFETY NOTICE

The shaded area on this schematic diagram incorporates special features important for protection from fire and electrical shock hazards. When servicing it is essential that only manufacturer's specified parts be used for the critical components in the shaded areas of the schematic.

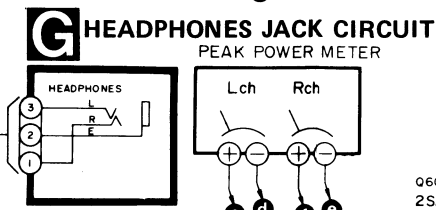
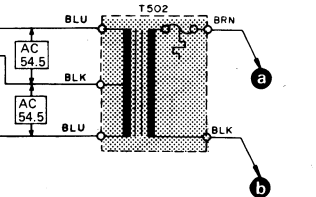
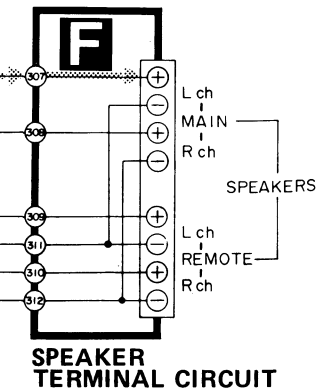

Q602 2SA1015 RELAY DRIVE

MC-Service

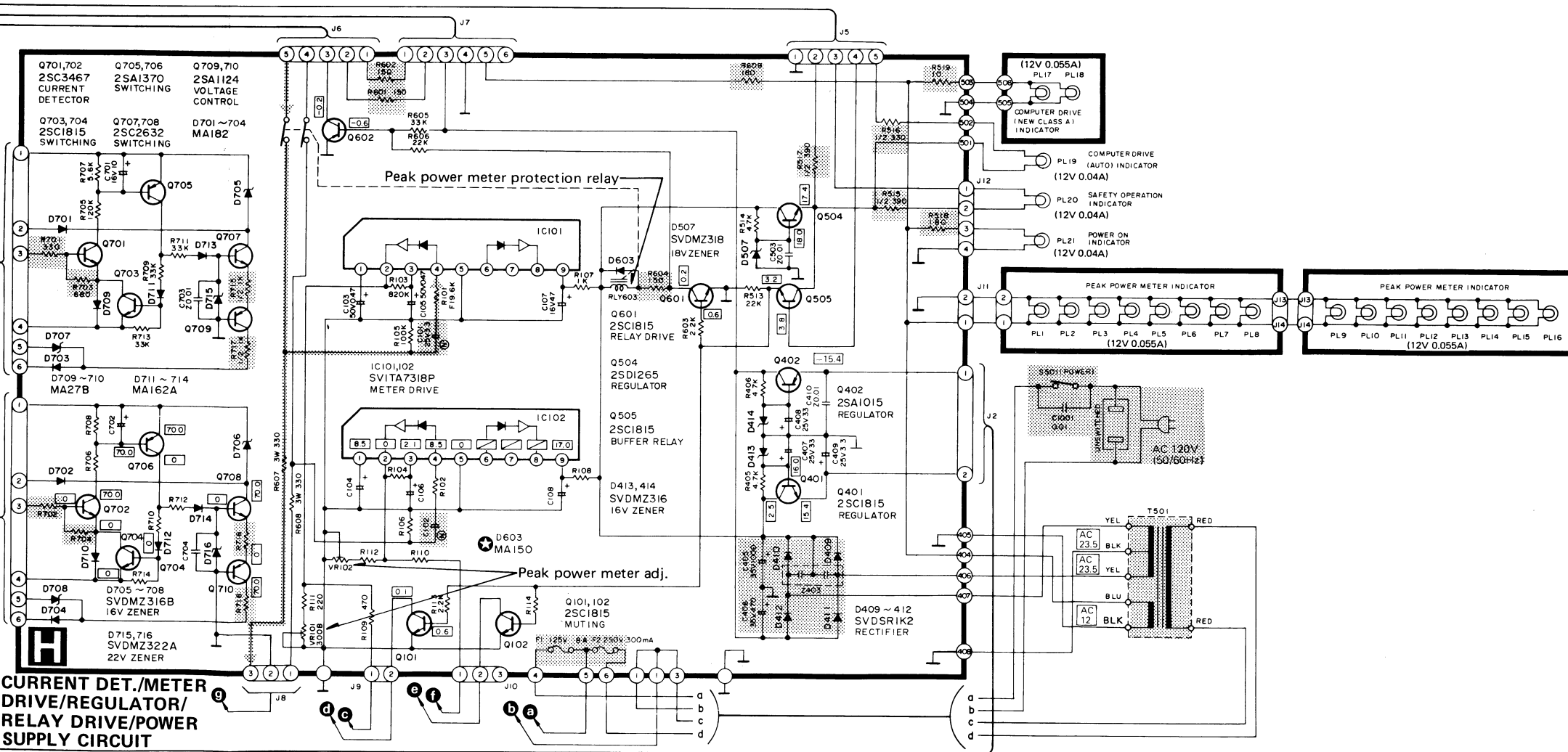

Terminal guide of transistors, diodes and IC's

Table with 4 columns and 6 rows providing terminal guides for various components: MN1404STE (16 pin), AN6552 (8 pin), SVITA7318P, 2SK117, 2SD1265, 2SA1306, 2SC3298, MA162A, MA1062M, MA150, MA182, 0A90AR, MA27W-A, SVDS10VB20F, SVDSR1K2, SVDMZ316, SVDMZ318, SVDMZ322.



## REPLACEMENT PARTS LIST . . . Cabinet & Chassis Parts

- Notes:**
- Part numbers are indicated on most mechanical parts. Please use this part number for parts orders.
  - Important safety notice:  
Components identified by  $\Delta$  mark have special characteristics important for safety. When replacing any of these components use only manufacturer's specified parts.
  - The "S" mark is service standard parts and many differ from production parts.
  - The parenthesized numbers in the column of description stand for the quantity per set.
  - Bracketed indications in Ref. No. columns specify the areas. Parts without these indications can be used for all areas.

### Areas

- \* [M] is available in the U.S.A.
- \* [MC] is available in Canada.

## EXPLODED VIEWS

Ref. No.	Part No.	Part Name & Description
<b>INTEGRATED CIRCUITS</b>		
IC21	MN1404STE	ICQ Controller
IC101, 102	SVITA7318P	Meter Drive
IC301	AN6552F	DC Servo
<b>TRANSISTORS</b>		
Q21~29, 101, 102, 313, 314, 337, 338, 401, 503, 505, 601, 703, 704	2SC1815-Y	Signal Detector, DC Detector, Indicator Drive, Regulator, Muting, Current Stabilizer, Bias Control, ICQ Control, Switching
Q301~304	2SK117-GR	FET Differential Amp.
Q305~308	2SC1815-G	Cascade
Q309~312	2SC1845-E	Differential Amp.
Q315~318, 323, 324	2SA1370-D	Current Mirror, Pre Drive, Drive
Q319~322	2SC3467-D	Pre Drive, Drive
Q325, 326	2SC3298A-Y	Class A Drive
Q327, 328	2SA1306A-Y	Class A Drive
Q329~332	2SC3280-R	Power Amp.
Q333~336	2SA1301-R	Power Amp.
Q402, 602	2SA1015-Y	Regulator, Relay Drive
Q501, 502	2SC1845-E	Over load Detector
Q504	2SD1265-O	Regulator
Q701, 702	2SC3467-D	Current Detector
Q705, 706	2SA1370-D	Switching
Q707, 708	2SC2632-R	Switching
Q709, 710	2SA1124-R	Voltage Control
<b>DIODES</b>		
D21, 22, 301~306, 501~506, 601~603, 711~714	MA162A	Switching
D23	MA1062M	Zener, 6.2V
D307~310, 701~704	MA182	Switching
D311~318	OA90A-R	
D319~322	MA27W-A	
D401, 402	SVDS10VB20F	Rectifier
D409~412	SVDSR1K2	Rectifier
D413, 414	SVDMZ316A	Zener, 16V
D507	SVDMZ318	Zener, 18V
D705~708	SVDMZ316B	Zener, 16V
D709, 710	MA27B	Zener, 16V
D715, 716	SVDMZ322A	Zener, 22V
<b>COILS</b>		
L301, 302	SLQY15G-30	Choke Coil
<b>TRANSFORMERS</b>		
T501	SLT5S68	Power Source
T502	SLT5L178	Meter
<b>VARIABLE RESISTORS</b>		
VR101, 102	EVNK6AA00B32	Power Meter Adj., 300 $\Omega$ (B)
VR201, 202	EVH6UA524B54	Input Level, 50k $\Omega$ (B)
VR301, 302	EVNK6AA00B13	ICQ Adj., 1k $\Omega$ (B)
<b>THERMISTERS</b>		
TH301, 302	ERTD2ZHL333S	33k $\Omega$
<b>COMPONENT COMBINATIONS</b>		
Z401~403	SXRF203ZSM	0.01 $\mu$ F( $\times$ 2)

Ref. No.	Part No.	Part Name & Description
<b>THERMAL DETECTOR</b>		
PS501	SRPBG47101	
<b>RELAY</b>		
RLY601, 602	SSY124	Speaker
RLY603	SSY9	Meter
<b>LAMP</b>		
PL1~18	XAMR74S17	Meter (12V, 0.055A)
PL19~21	XAMR48S230	Computer Drive, Safety Operation, Power(12V, 0.04A)
PL22~24	XAMR48T250	Speaker Ind. (12V, 0.04A)
<b>METER</b>		
	SSM161-1	Peak Power Meter
<b>FUSES</b>		
F1	XBA1F80NU14	125V, 8A
F2	XBA2F03NU100	250V, 300mA
<b>SWITCHES</b>		
S1	SSS49	Input Selector
S2	SSH475	Speaker
S3	ESB9939T	Power Source
<b>CABINET PARTS and CHASSIS PARTS</b>		
1	SBC645-1A	Button, (off) (1)
2	SBC645-1B	Button, (main) (1)
3	SBC645-1C	Button, (remote) (1)
4	SBC645-1D	Button, (main and remote) (1)
5	SUS191-2	Spring, Button (4)
6	SGWEA5MK2-KM	Front Panel, Ass'y (1)
7	SHG6349	Rubber (4)
8	SGE693-1	Bracket, Left (1)
9	SGE693	Bracket, Right (1)
10	SGE697	Reflector Plate (1)
11	SGEEA5MK2-KN	Ornament (1)
12	SDE259-1	Filter, Lamp (1)
13	SMP305	Case, Lamp (1)
14	SUW2155	Bracket, Lamp Case (1)
15	SHG1575	Rubber, Lamp (6)
16	SHP9379	Sheet, Lamp (2)
17	SMP293	Bracket, Lamp (1)
18	SMK61	Bracket, Headphone (1)
19	SJJ71B	Jack, Headphone (1)
20	SUW1955	Bracket, Meter (1)
21	SBC627	Button, Power Source (1)
22	SDU35-1	Filter, Meter (1)
23	SHS6129	Sheet (2)
24	SMP371	Reflector Plate (1)
25	SJT345	Holder, Fuse (4)
26(M)	SKCEA5MK2-KM	Cabinet (1)
26(MC)	SKCEA5MK2-KC	Cabinet (1)
27	SML101-1	Bracket, Power Transformer (1)
28	SUW2153-3	Bracket (1)
29	SMN1895-1	Bracket (1)
30	SUW1595	Bracket (1)
31	SUW1701	Bracket (1)
32	SUW1593	Bracket (1)

Ref. No.	Part No.	Part Name & Description
<b>CABINET PARTS and CHASSIS PARTS</b>		
33	SUW2153-2	Bracket (1)
34	SKU8210-3	Bottom Board (1)
35	SKL247-2	Foot, Bottom Side (4)
36	SJF3225-2A	Terminal Board (1)
37	SMN1729-1	Bracket, Input Level Volume (1)
38	SJT231	Terminal (1)
39	SJF4817	Terminal Board, Speaker (1)
40	SHR129	Bushing (1)
41	SJA129-1	AC Cord (1)
42(M)	SJS9221	Socket, AC Outlet (1)
42(MC)	SJS9223	Socket, AC Outlet (1)
43(M)	SGP2391C	Rear Panel (1)
43(MC)	SGPEA5MK2-KC	Rear Panel (1)
44	SBN613	Knob, Input Level Volume (2)
45	SKL241	Foot, Rear Side (4)
46	SHG1509	Rubber, Button (4)
47	SHS2445	Sheet (2)
48	SHS2437	Sheet (1)
<b>SCREWS</b>		
N1	XTB3+8BFZ	Tapping, $\phi$ 3 $\times$ 8 (30)
N2	XTS3+8BFZ	Tapping, $\phi$ 3 $\times$ 8 (4)
N3	XSN3+6S	$\phi$ 3 $\times$ 6 (4)
N4	XTBS3+8BFZ1	Tapping with Detent, $\phi$ 3 $\times$ 8 (42)
N5	XTN3+8B	Tapping, $\phi$ 3 $\times$ 8 (2)
N6	XSS5+12FIS	$\phi$ 5 $\times$ 12 (8)
N7	XTB4+10BFN	Tapping, $\phi$ 4 $\times$ 10 (2)
N8	XTB4+8F	Tapping, $\phi$ 4 $\times$ 8 (8)
N9	XTW3+12J	Tapping, $\phi$ 3 $\times$ 12 (8)
N10	XTB3+10FFZ	Tapping, $\phi$ 3 $\times$ 10 (4)
N11	XTB4+12FFZ	Tapping, $\phi$ 4 $\times$ 12 (4)
<b>WASHERS</b>		
N15	XWA3B	Spring, $\phi$ 3 (5)
N16	XWG3	Plain, $\phi$ 3 (2)
N17	SNE59-1	(1)
N18	XWC3B	External Toothed Lock, $\phi$ 3 (1)
<b>NUTS</b>		
N20	XNS12	$\phi$ 12 (1)
N21	XNG3ES	$\phi$ 3 (1)
N22	SNE4021	(2)
<b>ACCESSORIES</b>		
A1	SJP2239	Cord, Connection (1)
A2(M)	SQF12032	Instruction Book (1)
A2(MC)	SQF12033	Instruction Book (1)
<b>PACKING PARTS</b>		
P1	SPP653	Polyethylene Bag (1)
P2	SPH211	Sheet (1)
P3	SPS4303-1	Pad, Bottom (1)
P4	SPS4305-2	Pad, Upper (1)
P5(M)	SPG4787	Carton Box (1)
P5(MC)	SPG4788	Carton Box (1)

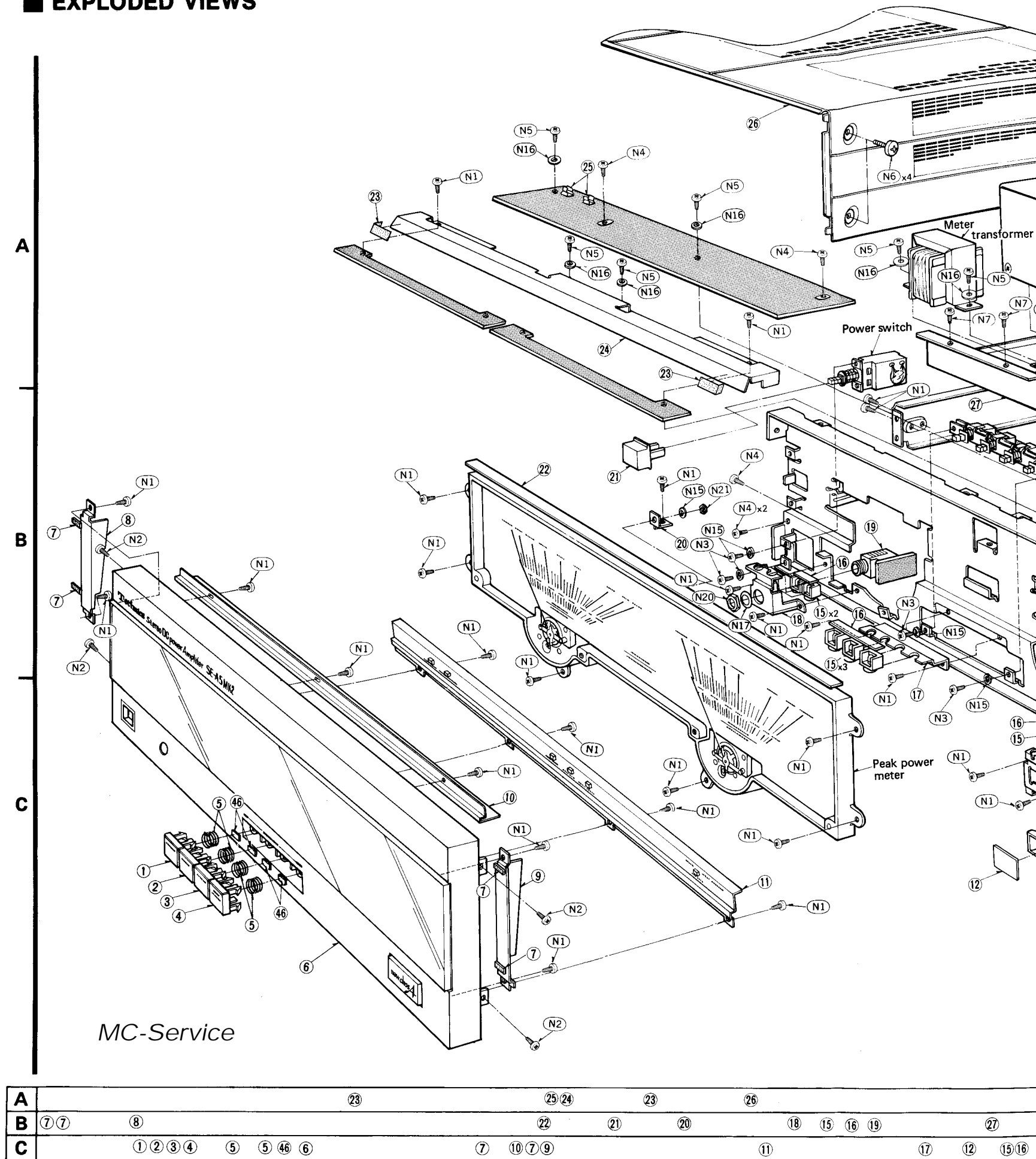

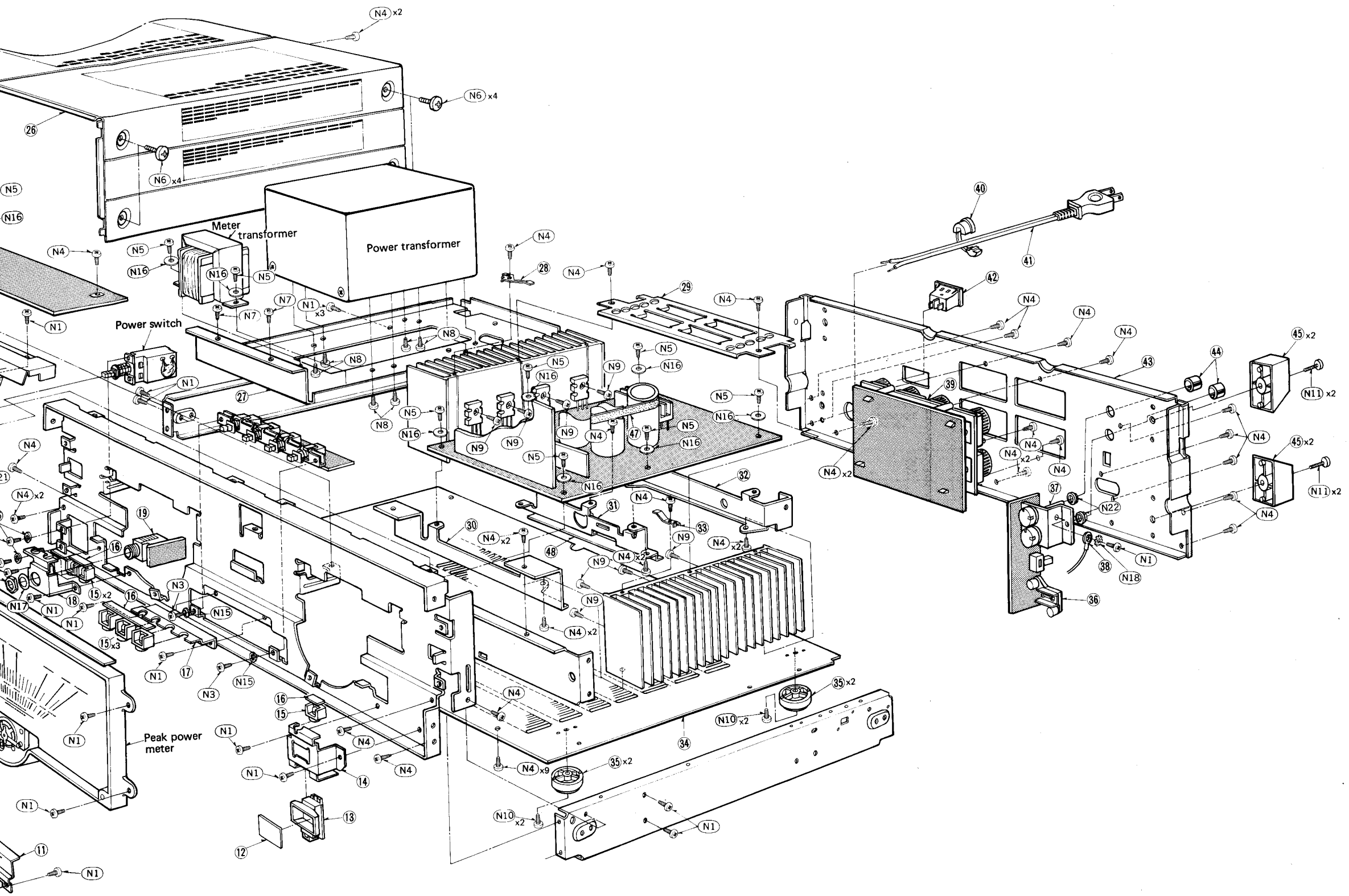

MC-Service

26	28	29	40	42	41	43	44	45							
18	15	16	19	27	30	48	31	47	33	32	39	37	36	38	45
11	17	12	15	16	13	14	35	34	35						