

Service Manual

Stereo DC Power Amplifier

SE-A70

SE-A70

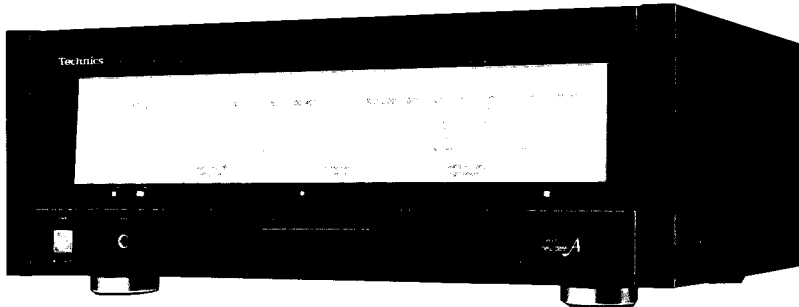

Color

(K)...Black Type

Color	Areas
(K)	[PA]...Far East PX.
(K)	[PE]...European Military.

Please use this manual together with the service manual for Model No. SE-A5MK2, Order No. HAD84032731C1.

SPECIFICATIONS

(IHF '78)

■ AMPLIFIER SECTION

Rated minimum sine wave RMS power output	
20 Hz~20 kHz both channels driven	
0.002% total harmonic distortion	160W per channel (8 ohms)
20 Hz~20 kHz both channels driven	
0.002% total harmonic distortion	160W per channel (4 ohms)
1 kHz continuous power output	
both channels driven	
0.002% total harmonic distortion	160W per channel (8 ohms)
0.002% total harmonic distortion	160W per channel (4 ohms)
Dynamic headroom	
	1.5 dB (8 ohms)
	3.6 dB (4 ohms)
Total harmonic distortion	
rated power at 20 Hz~20 kHz	0.002% (8 ohms/4 ohms)
half power at 20 Hz~20 kHz	0.001% (8 ohms)
half power at 1 kHz	0.0005% (8 ohms)
Power bandwidth	
both channels driven, -3 dB T.H.D. 0.01%	5 Hz~100 kHz (8 ohms)
Transient intermodulation distortion	unmeasurably small
SMPTE intermodulation distortion	0.002% (8 ohms)
Frequency response	
	DC~20 kHz (+0 dB, -0.1 dB)
	DC~150 kHz (+0 dB, -3 dB)

Input sensitivity	90 mV (1V, IHF '66)
S/N (IHF, A)	102 dB (121 dB, IHF '66)
Residual hum and noise	0.13 mV
Input impedance	47 kilohms
Low frequency damping factor	100 (8 ohms) 50 (4 ohms)
Load impedance	
MAIN or REMOTE	4~16 ohms
MAIN and REMOTE	8~16 ohms
Meter	
reading range	0.0001W~400W -60 dB~+4 dB (logarithmic compression)
frequency response (reading accuracy)	
	20 Hz~20 kHz ± 2 dB (more than -50 dB)
	20 Hz~20 kHz ± 3 dB (less than -50 dB)

■ GENERAL

Power consumption	980W
Power supply	AC 110V/120V/220V/240V, 50 Hz/60 Hz
Dimensions (W×H×D)	476 × 178 × 416 mm (18-23/32" × 7" × 16-3/8")
Weight	20.4 kg (44.88 lb.)

Note:

Total harmonic distortion is measured by the digital spectrum analyzer (H.P. 3045 system).

Specifications are subject to change without notice for further improvement.

Weights and dimensions shown are approximate.

Technics

Matsushita Electric Trading Co., Ltd.
P.O. Box 288, Central Osaka Japan

Panasonic Tokyo Office
Matsushita Electric Trading Co., Ltd.
6th Floor, World Trade Center Bldg.,
No. 4-1, Hamamatsu-cho 2-Chome, Minato-ku,
Tokyo 105, Japan

■ LOCATION OF CONTROLS

• Rear panel

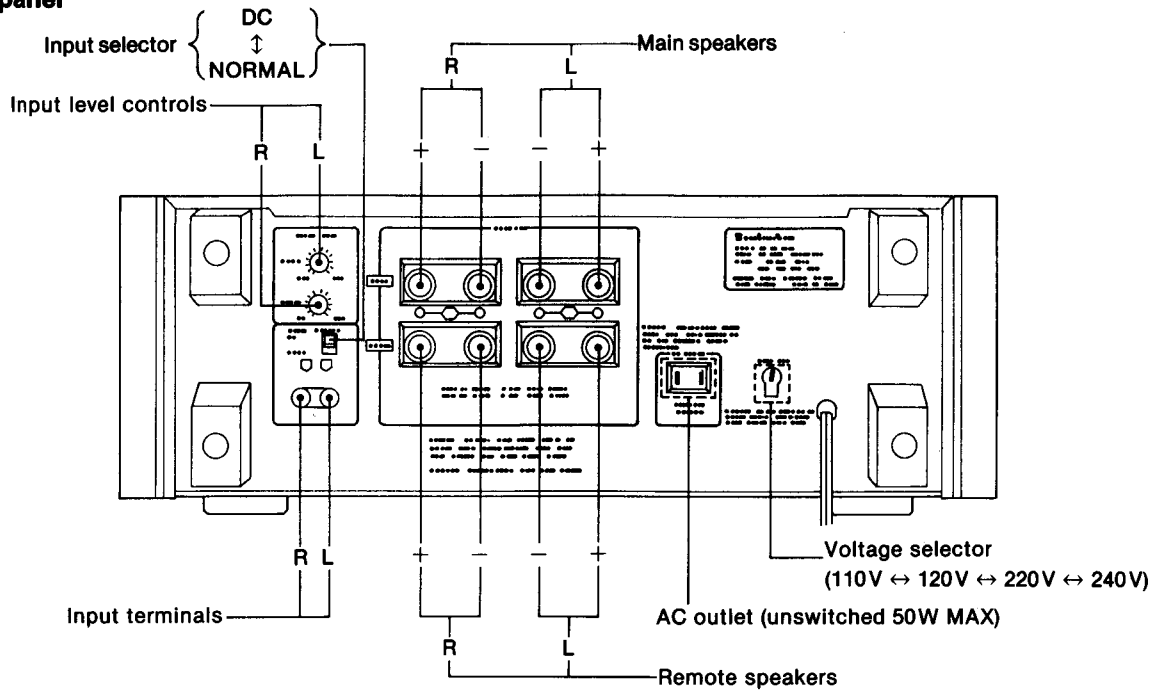

■ BEFORE REPAIR AND ADJUSTMENT

1. Turn off the power, Discharge both power supply capacitors (C401, 403, 402, 404, 8200 μ F) through a 10 Ω 5W resistor to ground. Do not short between C401, 403 and C402, 403. It may damage the capacitors.
2. After completion of repair, slowly apply the primary voltage by using a variac to avoid over current. Current consumption at 50Hz in no signal mode should be shown with respect to supply voltage 110V/120V/220V/240V.

Power supply voltage		110V	120V	220V	240V
Consumed current	50/60 Hz	0.41~0.93 A	0.37~0.84 A	0.21~0.46 A	0.19~0.44 A

CHANGE

■ CHANGE OF THE REPLACEMENT PARTS LIST

- Notes:**
- Please use this part number for parts orders.
 - Important safety notice:
Components identified by Δ mark have special

characteristics important for safety. When replacing any of these components use only manufacturer's specified parts.

Ref. No.	Change of Parts No.		Part Name & Description
	SE-A5MK2 (M)	SE-A70 (PA, PE)	
TRANSFORMERS			
T501 Δ	SLT5S68	SLT5S70	Power Source
T502 Δ	SLT5L178	SLT5L178-1	Power Source
METER			
	SSM161-1	SSM183	Power Meter
FUSES			
F1 Δ	XBA1F80NU14	XBA2C40TR0	250V, 4A
F2 Δ	XBA2F03NU100	XBA2C40TR0	250V, 4A
F3 Δ	—	XBA2C03TR0	250V, 315mA (Addition)
SWITCH			
S601 Δ	—	ESE37200	Voltage Selector (Addition)
RESISTORS			
R407, 408 Δ	—	ERD25FJ2R2	2.2 (Addition)
R604	ERD25FJ151	ERDS1FJ821	820
R703, 704	ERD25FJ681	ERD25FJ561	560
CAPACITOR			
C909, 910	—	ECKT1H333ZF	0.033 (Addition)

Ref. No.	Change of Parts No.		Part Name & Description	
	SE-A5MK2 (M)	SE-A70 (PA, PE)		
CABINET and CHASSIS PARTS				
1	SBC645-1A	SBC645-3A	Button, (off)	(1)
2	SBC645-1B	SBC645-3B	Button, (main)	(1)
3	SBC645-1C	SBC645-3C	Button, (remote)	(1)
4	SBC645-1D	SBC645-3D	Button, (main and Remote)	(1)
6	SGWEA5MK2-KM	SGWEA70-KP	Front Panel Ass'y	(1)
8	SGE693-1	SGE693-3	Bracket, Left	(1)
9	SGE693	SGE693-2	Bracket, Right	(1)
10	SGE697	SGE697-1	Reflector Plate	(1)
11	SGEEA5MK2-KN	SGEEA70-KP	Ornament	(1)
12	SDE259-1		Detection, Lamp Filter	
13	SMP305		Detection, Lamp Case	
21	SBC627	SBC666-3	Power Button	(1)
25	SJT345	SJT347	Fuse Holder	(6)
26	SKCEA5MK2-KM	SKCEA70-KP	Cabinet	(1)
35	SKL247-2	SKL295	Foot, Bottom Side	(4)
40	SHR129	SHR127	Bushing	(1)
41	△ SJA129-1	SJA121	AC Cord	(1)
43	SGP2391C	SGPEA70-KP	Rear Panel	(1)
49		SKZEA70-KP1	Addition, Side Panel (Right)	(1)
50		SKZEA70-KP2	Addition, Side Panel (Left)	(1)
51		SMN1685-3	Addition, Bracket	(1)
52		SHR301	Addition, Cord Clamper	(1)
53		SJT783	Addition, Connector Pin	(41)
54		SJS5215	Addition, Connector (J2, 9, 11)	(3)
54		SJS5331	Addition, Connector (J1, 8, 10)	(3)
54		SJS5425	Addition, Connector (J12)	(1)
54		SJS5523	Addition, Connector (J5, J6)	(2)
54		SJS5629	Addition, Connector (J7)	(1)
55		SJT3213	Addition, Post (J2, 9, 11)	(3)
55		SJT3319	Addition, Post (J1, 8, 10)	(3)
55		SJT3415	Addition, Post (J12)	(1)
55		SJT3511	Addition, Post (J5, 6)	(2)
55		SJT3611	Addition, Post (J7)	(1)

REPLACEMENT PARTS LIST

- Notes:**
- Part numbers are indicated on most mechanical parts. Please use this part number for parts orders.
 - Important safety notice: Components identified by △ mark have special characteristics important for safety. When replacing any of these components use only manufacturer's specified parts.
 - The parenthesized numbers in the column of description stand for the quantity per set.

Resistor Type	Wattage	Tolerance	Capacitor Type	Voltage		Tolerance
				ECEA Type	Other	
ERD : Carbon	10 : 1/8W	J : ±5%	ECEA : Electrolytic	0J : 6.3V	1H : 50V	D : ±0.5pF
ERG : Metal Oxide	25 : 1/4W	G : ±5%	ECCD : Ceramic	1A : 10V	KC : 400V AC	K : ±10%
ERO : Metal Film	2 : 2W		ECKD : Ceramic	1C : 16V	2H : 500V	Z : +80%, -20%
ERF : Non-flammable	S1 : 1/2W		ECQM : Polyester	1E : 25V		P : +100%, -0%
	3 : 3W		ECET : Electrolytic	1H : 50V		
			ECEA...N : Non Polar Electrolytic	50 : 50V		
				25 : 25V		
				45 : 45V		
				2A : 100V		

ERD10TLJ □□□ → Chip type carbon

CAPACITORS

Ref. No.	Part No.	Value	Ref. No.	Part No.	Value	Ref. No.	Part No.	Value	Ref. No.	Part No.	Value
C21, 22	ECEA1EU3R3	3.3	C203, 204	ECCD1H120KC	12P	C502	ECEA0JU470	47	C503	ECKD1H103ZF	0.01
C23	ECEA1CU100	100	C301, 302	ECCD1H101K	100P	C331, 332	ECKD1H681KB	680P	C504	ECEA1HU010	1
C24	ECEA1CU101	100	C303, 304	ECKD1H681KB	680P	C333, 334	ECKD1H681KB	680P	C701, 702	ECEA1CU100	10
C25	ECEA1HUR47	0.47	C307, 308	ECCD2H070D	7P	C339, 340	ECQM1H473KV	0.047	C703, 704	ECKD1H103ZF	0.01
C26	ECCD1H121K	120P	C309, 310	ECCD2H070D	7P	C401, 402	ECET1KV822Z	8200	C801, 802	ECCD1H101K	100P
C27	ECEA0JU101	100	C311, 312	ECCD2H270K	27P	C403, 404	ECET1KV822Z	8200	C803, 804	ECKD1H221KB	220P
C28	ECKD1H223ZF	0.022	C313, 314	ECCD2H270K	27P	C405	ECEA1VU102	1000	C805, 806	ECKD1H221KB	220P
C101, 102	△ ECEA1EN3R3S	3.3	C315, 316	ECEA1HU330	33	C406	ECEA1VU471	470	C909, 910	ECKT1H333ZF	0.033
C103, 104	ECEA1HUR47	0.47	C317, 318	ECEA2AU010	1	C407, 408	ECEA1EU330	33	C1001	△ ECKDKC103PF2	0.01
C105, 106	ECEA1HUR47	0.47	C321, 322	ECEA1CU100	10	C409	ECEA1EU3R3	3.3			
C107, 108	ECEA1CU470	47	C323, 324	ECEA1EU4R7	4.7	C410	ECKD1H103ZF	0.01			
C201, 202	△ ECEA1HN2R2S	2.2	C325, 326	△ ECEA25N4R7	4.7	C501	ECEA1HU010	1			

RESISTORS

Ref. No.	Part No.	Value	Ref. No.	Part No.	Value	Ref. No.	Part No.	Value	Ref. No.	Part No.	Value
R21, 22	ERD10TLJ223U	22K	R301, 302	ERD25FJ221	220	R363, 364	△ ERD25FJ271	270	R514	ERD25FJ472	4.7K
R23, 24	ERD10TLJ223U	22K	R305, 306	ERD25FJ272	2.7K	R365, 366	△ ERD25FJ2R2	2.2	R515	△ ERDS1FJ391	390
R25, 26	ERD10TLJ333U	33K	R307, 308	ERD25FJ392	3.9K	R367, 368	△ ERD25FJ2R2	2.2	R516	△ ERDS1FJ331	330
R27, 28	ERD10TLJ123U	12K	R309, 310	ERD25FJ392	3.9K	R369, 370	△ ERD25FJ2R2	2.2	R517	△ ERDS1FJ391	390
R29	ERD25FJ472	4.7K	R311, 312	ERD25FJ393	39K	R371, 372	△ ERD25FJ2R2	2.2	R518	△ ERD25FJ181	180
R30, 31	ERD10TLJ103U	10K	R313, 314	ERD25FJ103	10K	R373, 374	△ ERF3RKR33	0.33	R519	△ ERD25FJ100	10
R32	ERD25FJ103	10K	R315, 316	ERD25FJ330	33	R375, 376	△ ERF3RKR33	0.33	R520	ERD25TJ683	68K
R33	ERD10TLJ102U	1K	R317, 318	ERD25FJ393	39K	R377, 378	△ ERF3RKR33	0.33	R601, 602	△ ERD25FJ151	150
R34, 35	ERD10TLJ104U	100K	R319, 320	ERD25FJ102	10K	R379, 380	△ ERF3RKR33	0.33	R603	ERD25FJ222	2.2K
R36	ERD10TLJ333U	33K	R321, 322	ERD25FJ561	560	R381, 382	△ ERD25TJ224	220K	R604	△ ERDS1FJ821	820
R37, 38	ERD25FJ822	8.2K	R323, 324	ERD25FJ471	470	R383, 384	ERD25TJ224	220K	R605	ERD25TJ333	33K
R39	ERD25TJ394	390K	R325, 326	ERD25FJ151	150	R385, 386	△ ERD25FJ3R3	3.3	R606	ERD25TJ223	22K
R40	ERD25TJ223	22K	R327, 328	ERD25FJ151	150	R387, 388	△ ERD25FJ3R3	3.3	R607, 608	ERG3ANJ331	330
R41, 42	ERD10TLJ223U	22K	R329, 330	ERD25FJ102	1K	R389, 390	△ ERD25FJ100	10	R609	△ ERD25FJ181	180
R43	ERD10TLJ223U	22K	R331, 332	ERD25FJ821	820	R391, 392	ERG2ANJ100	10	R701, 702	△ ERD25FJ331	330
R44, 45	ERD25TJ223	22K	R333, 334	ERD25FJ102	1K	R393, 394	△ ERD25FJ100	10	R703, 704	△ ERD25FJ561	560
R46	ERD10TLJ392U	3.9K	R335, 336	ERD25FJ102	1K	R395, 396	△ ERD25FJ561	560	R705, 706	ERD25TJ124	120K
R47	ERD25FJ472	4.7K	R337, 338	△ ERD25FJ681	680	R397, 398	△ ERD25FJ222	2.2K	R707, 708	ERD25FJ562	5.6K
R48	ERD10TLJ392U	3.9K	R339, 340	△ ERD25FJ681	680	R401, 402	△ ERD2FCG5R6	5.6	R709, 710	ERD25TJ333	33K
R49	ERD10TLJ153U	15K	R341, 342	△ ERD25FJ101	100	R403, 404	ERD2FCG5R6	5.6	R711, 712	ERD25TJ333	33K
R50	ERD10TLJ103U	10K	R343, 344	△ ERD25FJ101	100	R405, 406	ERD25FJ472	4.7K	R713, 714	ERD25TJ333	33K
R101, 102	ERO25CKF1962	19.6K	R345, 346	△ ERD25FJ101	100	R407, 408	ERD25FJ2R2	2.2	R715, 716	△ ERDS1F102	1K
R103, 104	ERD25TJ824	820K	R347, 348	△ ERD25FJ101	100	R501, 502	△ ERD25FJ222	2.2K	R717, 718	△ ERDS1F102	1K
R105, 106	ERD25TJ104	100K	R349, 350	△ ERD25FJ102	1K	R503, 504	△ ERD25FJ681	680	R801, 802	ERD25FJ103	10K
R107, 108	ERD25FJ102	1K	R351, 352	ERD25FJ102	1K	R505, 506	△ ERD25FJ331	330	R803, 804	ERD25TJ224	220K
R109, 110	ERD25FJ471	470	R353, 354	ERD25TJ333	33K	R507, 508	ERD25TJ183	18K	R805, 806	ERD25TJ224	220K
R111, 112	ERD25FJ221	220	R355, 356	ERD25TJ104	100K	R509	ERD25TJ183	18K	R851, 852	ERD25TJ393	39K
R113, 114	ERD25FJ222	2.2K	R357, 358	ERD25TJ104	100K	R511	ERD25TJ104	100K	R853, 854	ERD25FJ122	1.2K
R201, 202	ERD25FJ222	2.2K	R359, 360	ERD25TJ223	22K	R512	ERD25TJ224	220K			
R203, 204	ERD25TJ224	220K	R361, 362	ERD25TJ823	82K	R513	ERD25TJ223	22K			

Ref. No.	Part No.	Description	Ref. No.	Part No.	Description
INTEGRATED CIRCUITS					
IC21	MN1404STE	ICQ Controller	D23	MA1062M	Zener, 6.2V
IC101, 102	SVITA7318P	Meter Drive	D307~310, 701~704	MA182	Switching
IC301	AN6552F	DC Servo	D311~318	OA90A-R	
TRANSISTORS					
Q21~29, 101, 102, 313, 314, 337, 338, 401, 503, 505, 601, 703, 704	2SC1815-Y	Signal Detector, DC Detector, Indicator Drive, Regulator, Muting, Current Stabilizer, Bias Control, ICQ Control, Switching	D401, 402	MA27W-A	Rectifier
			D409~412	SVDS10VB20F	Rectifier
			D413, 414	SVDSR1K2	Rectifier
			D507	SVDMZ316	Zener, 18V
			D705~708	SVDMZ316B	Zener, 16V
			D709, 710	MA27B	
			D715, 716	SVDMZ322A	Zener, 22V
Q301~304	2SK117-GR	FET Differential Amp.	COILS		
Q305~308	2SC1815-G	Cascade	L301, 302	SLQY15G-30	Choke Coil
Q309~312	2SC1845-E	Differential Amp.	TRANSFORMERS		
Q315~318, 323, 324	2SA1370-D	Current Mirror, Pre Drive, Drive	T501	△ SLT5S70	Power Source
Q319~322	2SC3467-D	Pre Drive, Drive	T502	△ SLT5L178-1	Meter
Q325, 326	2SC3298A-Y	Class A Drive	VARIABLE RESISTORS		
Q327, 328	2SA1306A-Y	Class A Drive	VR101, 102	EVNK6AA00B32	Power Meter Adj., 300Ω(B)
Q329~332	2SC3280-R	Power Amp.	VR201, 202	EVH6UA524B54	Input Level, 50kΩ(B)
Q333~336	2SA1301-R	Power Amp.	VR301, 302	EVNK6AA00B13	ICQ Adj., 1kΩ(B)
Q402, 602	2SA1015-Y	Regulator, Relay Drive	THERMISTERS		
Q501, 502	2SC1845-E	Over Load Detector	TH301, 302	ERTD2ZHL333S	33kΩ
Q504	2SD1265-O	Regulator	COMPONENT COMBINATIONS		
Q701, 702	2SC3467-D	Current Detector	Z401~403	△ SXRF203ZSM	0.01μF (×2)
Q705, 706	2SA1370-D	Detector	THERMAL DETECTOR		
Q707, 708	2SC2632-R	Switching	PS501	SRPBG47101	
Q709, 710	2SA1124-R	Voltage Control			
DIODES					
D21, 22, 301~306, 501~506, 601~603, 711~714	MA162A	Switching			

Ref. No.	Part No.	Description
RELAYS		
RLY601, 602	△ SSY124	Speaker
RLY603	△ SSY9	Meter
LAMPS		
PL1~16	XAMR74S17	Meter (12V, 0.055A)
PL19~21	XAMR48S230	Computer Drive, Safety Operation, Power (12V, 0.04A)
PL22~24	XAMR48T250	Speaker Ind. (12V, 0.04A)
METER		
	SSM183	Peak Power Meter
FUSES		
F1, 2	△ XBA2C40TR0	250V, 4A
F3	△ XBA2C03TR0	250V, 315mA
SWITCHES		
S1	SSS49	Input Selector
S2	SSH4	

Part Name & Description	Quantity
ion, Connector Pin	(10)
ion, Connector (J5, J6)	(2)
ion, Connector	(2)
ion, Connector	(2)
ion, Post	(2)
ion, Post	(2)
ion, Socket (J3, 4)	(2)
ing, 3x8	(36)
ing, 3x8	(4)
ing, 3x8	(4)
ing, 3x8	(14)
ing, 3x40	(8)
ing, 4x10	(2)
ing, 3x8	(8)
ion, Voltage Selector	(2)
ion, Washer	(8)
ion, Washer	(8)
er	(8)
p12	(1)
p3	(1)
Adaptor	(1)
ction Book	(1)
ethylene Bag	(1)
	(1)
ottom	(1)
pper	(1)
n Box	(1)
on, Pad, Front	(1)

replacing any of

Tolerance
: ±0.5pF
: ±10%
: +80%, -20%
: +100%, -0%

Part No.	Value
ECEA0JU470	47
ECKD1H103ZF	0.01
ECEA1HU010	1
ECEA1CU100	10
ECKD1H103ZF	0.01
ECCD1H101K	100P
ECKD1H221KB	220P
ECKD1H221KB	220P
ECKT1H333ZF	0.033
ECKDKC103PF2	0.01

RESISTORS

Ref. No.	Part No.	Value	Ref. No.	Part No.	Value	Ref. No.	Part No.	Value	Ref. No.	Part No.	Value
R21, 22	ERD10TLJ223U	22K	R301, 302	ERD25FJ221	220	R363, 364	ERD25FJ271	270	R514	ERD25FJ472	4.7K
R23, 24	ERD10TLJ223U	22K	R305, 306	ERD25FJ272	2.7K	R365, 366	ERD25FJ2R2	2.2	R515	ERDS1FJ391	390
R25, 26	ERD10TLJ333U	33K	R307, 308	ERD25FJ392	3.9K	R367, 368	ERD25FJ2R2	2.2	R516	ERDS1FJ331	330
R27, 28	ERD10TLJ123U	12K	R309, 310	ERD25FJ392	3.9K	R369, 370	ERD25FJ2R2	2.2	R517	ERDS1FJ391	390
R29	ERD25FJ472	4.7K	R311, 312	ERD25FJ393	39K	R371, 372	ERD25FJ2R2	2.2	R518	ERD25FJ181	180
R30, 31	ERD10TLJ103U	10K	R313, 314	ERD25FJ103	10K	R373, 374	ERF3RKR33	0.33	R519	ERD25FJ100	10
R32	ERD25FJ103	10K	R315, 316	ERD25FJ330	33	R375, 376	ERF3RKR33	0.33	R520	ERD25TJ683	68K
R33	ERD10TLJ102U	1K	R317, 318	ERD25TJ393	39K	R377, 378	ERF3RKR33	0.33	R601, 602	ERD25FJ151	150
R34, 35	ERD10TLJ104U	100K	R319, 320	ERD25FJ103	10K	R379, 380	ERF3RKR33	0.33	R603	ERD25FJ222	2.2K
R36	ERD10TLJ333U	33K	R321, 322	ERD25FJ561	560	R381, 382	ERD25TJ224	220K	R604	ERDS1FJ821	820
R37, 38	ERD25FJ822	8.2K	R323, 324	ERD25FJ471	470	R383, 384	ERD25TJ224	220K	R605	ERD25TJ333	33K
R39	ERD25TJ394	390K	R325, 326	ERD25FJ151	150	R385, 386	ERD25FJ3R3	3.3	R606	ERD25TJ223	22K
R40	ERD25TJ223	22K	R327, 328	ERD25FJ151	150	R387, 388	ERD25FJ3R3	3.3	R607, 608	ERG3ANJ331	330
R41, 42	ERD10TLJ223U	22K	R329, 330	ERD25FJ102	1K	R389, 390	ERD25FJ100	10	R609	ERD25FJ181	180
R43	ERD10TLJ223U	22K	R331, 332	ERD25FJ821	820	R391, 392	ERG2ANJ100	10	R701, 702	ERD25FJ331	330
R44, 45	ERD25TJ223	22K	R333, 334	ERD25FJ102	1K	R393, 394	ERD25FJ100	10	R703, 704	ERD25FJ561	560
R46	ERD10TLJ392U	3.9K	R335, 336	ERD25FJ102	1K	R395, 396	ERD25FJ561	560	R705, 706	ERD25TJ124	120K
R47	ERD25FJ472	4.7K	R337, 338	ERD25FJ681	680	R397, 398	ERD25FJ222	2.2K	R707, 708	ERD25FJ562	5.6K
R48	ERD10TLJ392U	3.9K	R339, 340	ERD25FJ681	680	R401, 402	ERD2FCG5R6	5.6	R709, 710	ERD25TJ333	33K
R49	ERD10TLJ153U	15K	R341, 342	ERD25FJ101	100	R403, 404	ERD2FCG5R6	5.6	R711, 712	ERD25TJ333	33K
R50	ERD10TLJ103U	10K	R343, 344	ERD25FJ101	100	R405, 406	ERD25FJ472	4.7K	R713, 714	ERD25TJ333	33K
R101, 102	ERO25CKF1962	19.6K	R345, 346	ERD25FJ101	100	R407, 408	ERD25FJ2R2	2.2	R715, 716	ERDS1FJ102	1K
R103, 104	ERD25TJ824	820K	R347, 348	ERD25FJ101	100	R501, 502	ERD25FJ222	2.2K	R717, 718	ERDS1FJ102	1K
R105, 106	ERD25TJ104	100K	R349, 350	ERD25FJ102	1K	R503, 504	ERD25FJ681	680	R801, 802	ERD25FJ103	10K
R107, 108	ERD25FJ102	1K	R351, 352	ERD25FJ102	1K	R505, 506	ERD25FJ331	330	R803, 804	ERD25TJ224	220K
R109, 110	ERD25FJ471	470	R353, 354	ERD25TJ333	33K	R507, 508	ERD25TJ183	18K	R805, 806	ERD25TJ224	220K
R111, 112	ERD25FJ221	220	R355, 356	ERD25TJ104	100K	R509	ERD25TJ183	18K	R851, 852	ERD25TJ393	39K
R113, 114	ERD25FJ222	2.2K	R357, 358	ERD25TJ104	100K	R511	ERD25TJ104	100K	R853, 854	ERD25FJ122	1.2K
R201, 202	ERD25FJ222	2.2K	R359, 360	ERD25TJ223	22K	R512	ERD25TJ224	220K			
R203, 204	ERD25TJ224	220K	R361, 362	ERD25TJ823	82K	R513	ERD25TJ223	22K			

Ref. No.	Part No.	Description
INTEGRATED CIRCUITS		
IC21	MN1404STE	ICQ Controller
IC101, 102	SVITA7318P	Meter Drive
IC301	AN6552F	DC Servo
TRANSISTORS		
Q21~29, 101, 102, 313, 314, 337, 338, 401, 503, 505, 601, 703, 704	2SC1815-Y	Signal Detector, DC Detector, Indicator Drive, Regulator, Muting, Current Stabilizer, Bias Control, ICQ Control, Switching
Q301~304	2SK117-GR	FET Differential Amp.
Q305~308	2SC1815-G	Cascade
Q309~312	2SC1845-E	Differential Amp.
Q315~318, 323, 324	2SA1370-D	Current Mirror, Pre Drive, Drive
Q319~322	2SC3467-D	Pre Drive, Drive
Q325, 326	2SC3298A-Y	Class A Drive
Q327, 328	2SA1306A-Y	Class A Drive
Q329~332	2SC3280-R	Power Amp.
Q333~336	2SA1301-R	Power Amp.
Q402, 602	2SA1015-Y	Regulator, Relay Drive
Q501, 502	2SC1845-E	Over Load Detector
Q504	2SD1265-O	Regulator
Q701, 702	2SC3467-D	Current Detector
Q705, 706	2SA1370-D	Switching
Q707, 708	2SC2632-R	Switching
Q709, 710	2SA1124-R	Voltage Control
DIODES		
D21, 22, 301~306, 501~506, 601~603, 711~714	MA162A	Switching

Ref. No.	Part No.	Description
DIODES		
D23	MA1062M	Zener, 6.2V
D307~310, 701~704	MA182	Switching
D311~318	OA90A-R	
D319~322	MA27W-A	
D401, 402	SVDS10VB20F	Rectifier
D409~412	SVDSR1K2	Rectifier
D413, 414	SVDMZ316	Zener, 16V
D507	SVDMZ318	Zener, 18V
D705~708	SVDMZ316B	Zener, 16V
D709, 710	MA27B	
D715, 716	SVDMZ322A	Zener, 22V
COILS		
L301, 302	SLQY15G-30	Choke Coil
TRANSFORMERS		
T501	SLT5S70	Power Source
T502	SLT5L178-1	Meter
VARIABLE RESISTORS		
VR101, 102	EVNK6AA00B32	Power Meter Adj., 300Ω(B)
VR201, 202	EVH6UA524B54	Input Level, 50kΩ(B)
VR301, 302	EVNK6AA00B13	ICQ Adj., 1kΩ(B)
THERMISTERS		
TH301, 302	ERTD2ZHL333S	33kΩ
COMPONENT COMBINATIONS		
Z401~403	SXRFS203ZSM	0.01μF (x2)
THERMAL DETECTOR		
PS501	SRPBG47101	

Ref. No.	Part No.	Description
RELAYS		
RLY601, 602	SSY124	Speaker
RLY603	SSY9	Meter
LAMPS		
PL1~16	XAMR74S17	Meter (12V, 0.055A)
PL19~21	XAMR48S230	Computer Drive, Safety Operation, Power (12V, 0.04A)
PL22~24	XAMR48T250	Speaker Ind. (12V, 0.04A)
METER		
	SSM183	Peak Power Meter
FUSES		
F1, 2	XBA2C40TR0	250V, 4A
F3	XBA2C03TR0	250V, 315mA
SWITCHES		
S1	SSS49	Input Selector
S2	SSH475	Speaker
S3	ESB99399S	Power Source
S601	ESE37200	Voltage Selector

SCHEMATIC DIAGRAM

Additional parts

Change of Power Supply

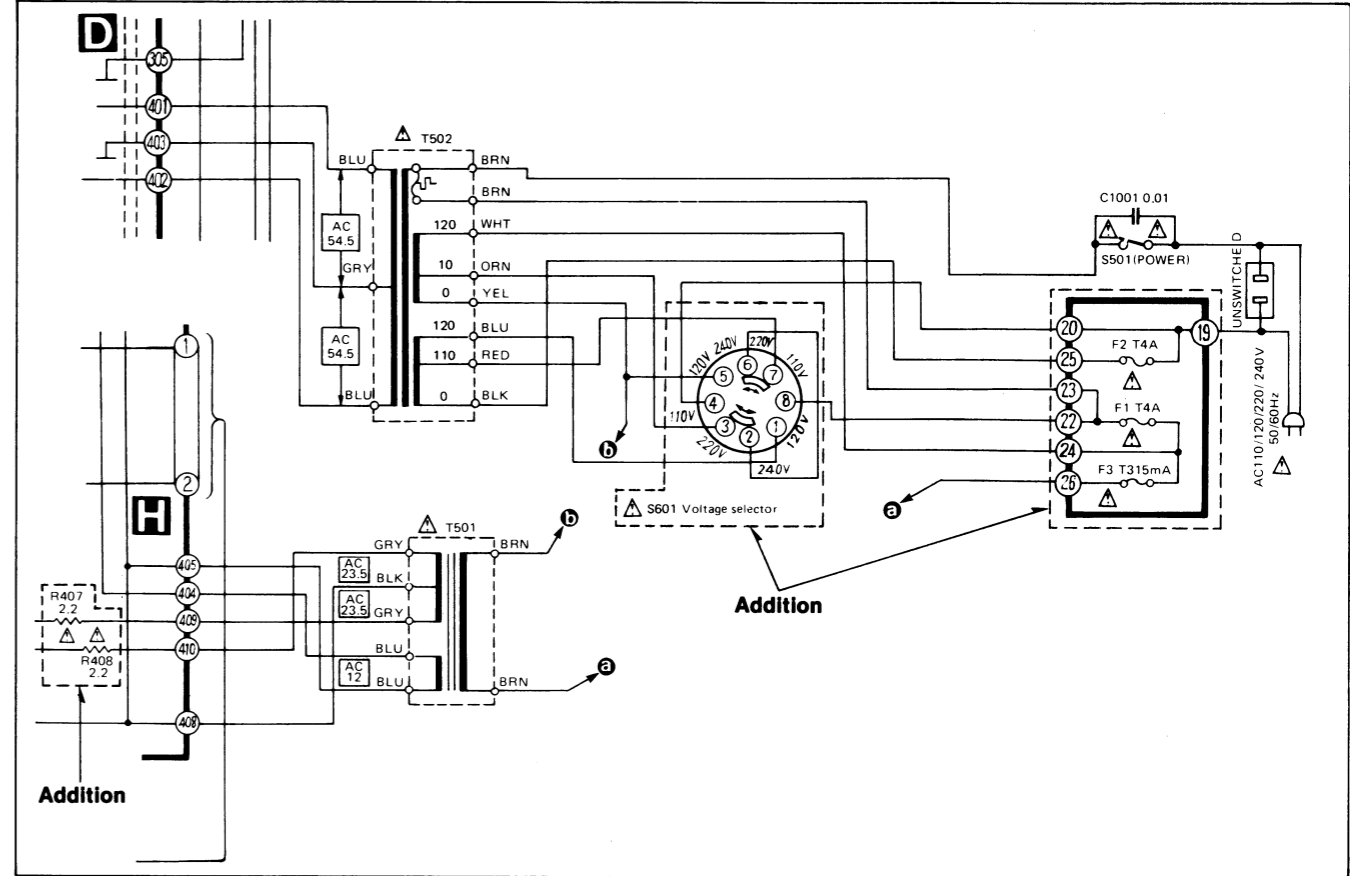
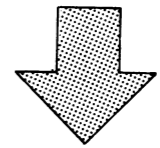
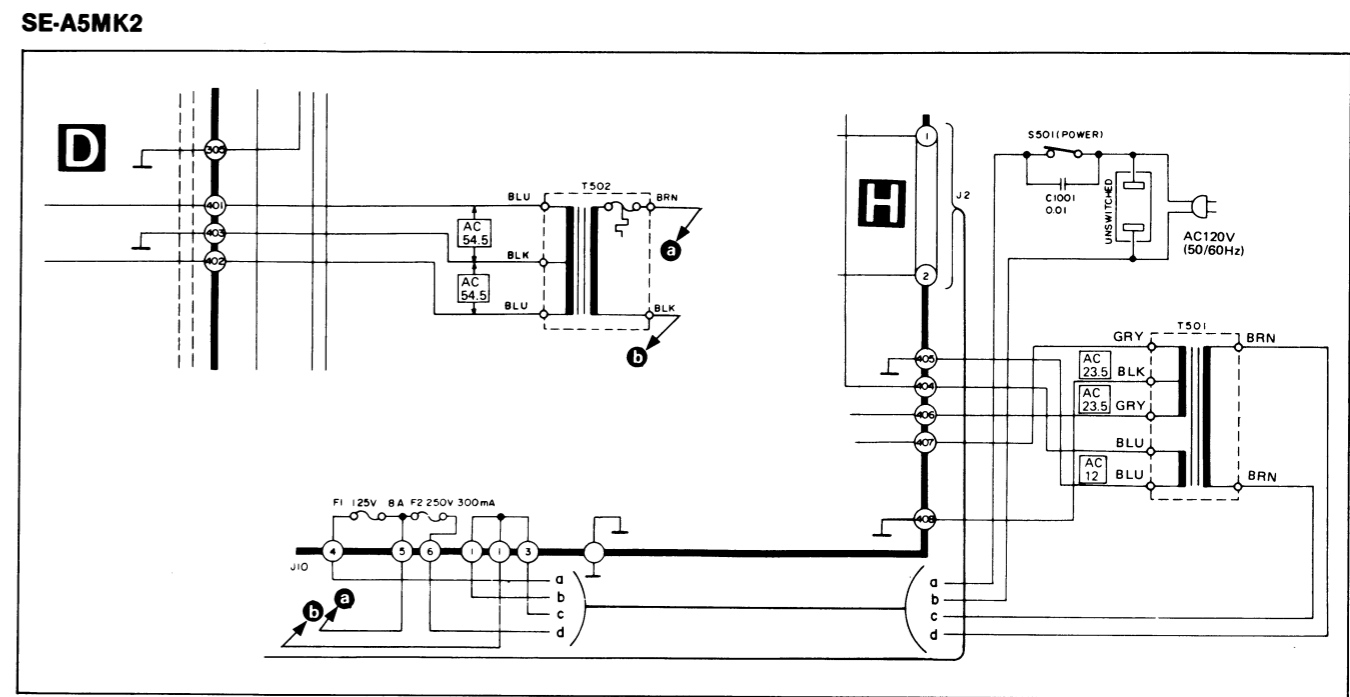

EXPLODED VIEW

A
B
C
D
E
F
G

1 2 3 4 5 6 7 8 9 10

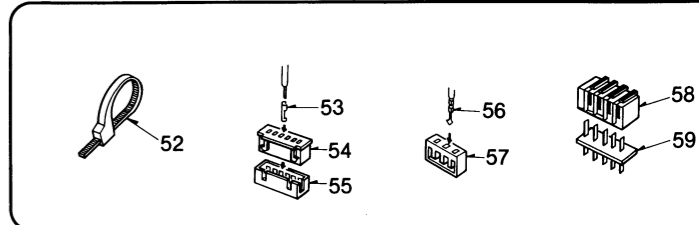
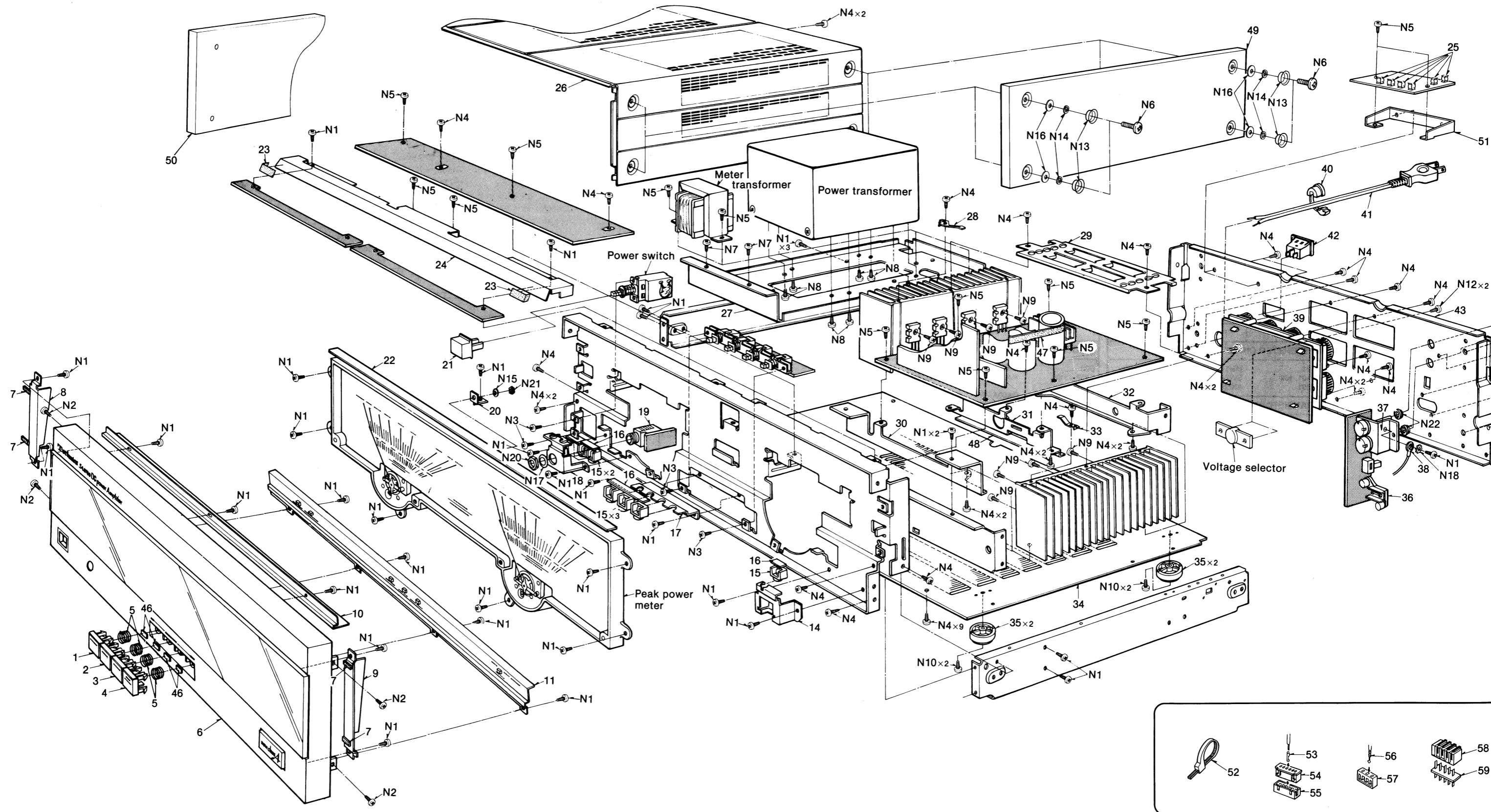

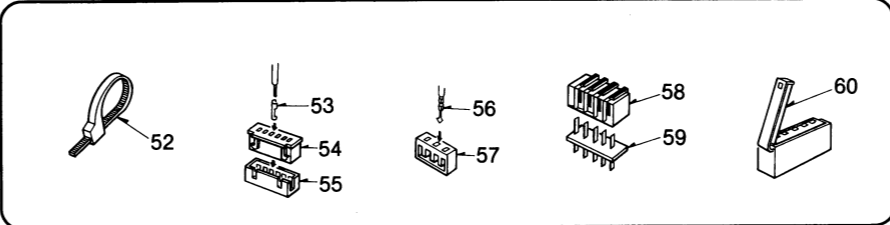
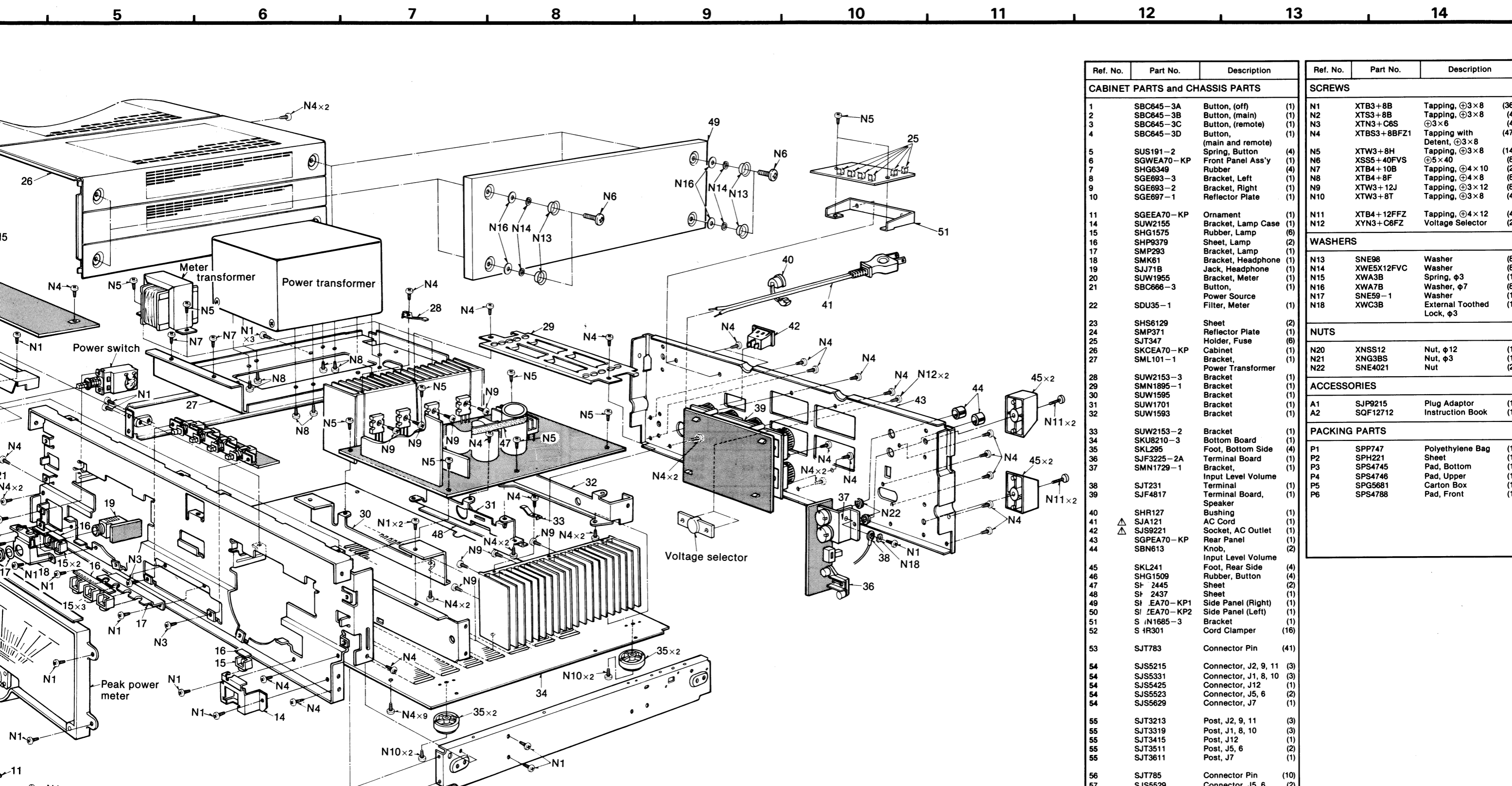

Ref. No.	Part No.	Description	QTY
CABINET PARTS and CHASSIS PARTS			
1	SBC645-3A	Button, (off)	(1)
2	SBC645-3B	Button, (main)	(1)
3	SBC645-3C	Button, (remote)	(1)
4	SBC645-3D	Button, (main and remote)	(1)
5	SUS191-2	Spring, Button	(4)
6	SGWEA70-KP	Front Panel Ass'y	(1)
7	SHG6349	Rubber	(4)
8	SGE693-3	Bracket, Left	(1)
9	SGE693-2	Bracket, Right	(1)
10	SGE697-1	Reflector Plate	(1)
11	SGEEA70-KP	Ornament	(1)
14	SUW2155	Bracket, Lamp Case	(1)
15	SHG1575	Rubber, Lamp	(6)
16	SHP9379	Sheet, Lamp	(2)
17	SMP293	Bracket, Lamp	(1)
18	SMK61	Bracket, Headphone	(1)
19	SJJ71B	Jack, Headphone	(1)
20	SUW1955	Bracket, Meter	(1)
21	SBC666-3	Button, Power Source	(1)
22	SDU35-1	Filter, Meter	(1)
23	SHS6129	Sheet	(2)
24	SMP371	Reflector Plate	(1)
25	SJT347	Holder, Fuse	(6)
26	SKCEA70-KP	Cabinet	(1)
27	SML101-1	Bracket, Power Transformer	(1)
28	SUW2153-3	Bracket	(1)
29	SMN1895-1	Bracket	(1)
30	SUW1595	Bracket	(1)
31	SUW1701	Bracket	(1)
32	SUW1593	Bracket	(1)
33	SUW2153-2	Bracket	(1)
34	SKU8210-3	Bottom Board	(1)
35	SKL295	Foot, Bottom Side	(4)
36	SJF3225-2A	Terminal Board	(1)
37	SMN1729-1	Bracket, Input Level Volume	(1)
38	SJT231	Terminal	(1)
39	SJF4817	Terminal Board, Speaker	(1)
40	SHR127	Bushing	(1)
41	SJA121	AC Cord	(1)
42	SJS9221	Socket, AC Outlet	(1)
43	SGPEA70-KP	Rear Panel	(1)
44	SBN613	Knob, Input Level Volume	(2)
45	SKL241	Foot, Rear Side	(4)
46	SHG1509	Rubber, Button	(4)
47	SF 2445	Sheet	(2)
48	SF 2437	Sheet	(1)
49	SI EA70-KP1	Side Panel (Right)	(1)
50	SI EA70-KP2	Side Panel (Left)	(1)
51	S IN1685-3	Bracket	(1)
52	S IR301	Cord Clammer	(16)
53	SJT783	Connector Pin	(41)
54	SJS5215	Connector, J2, 9, 11	(3)
54	SJS5331	Connector, J1, 8, 10	(3)
54	SJS5425	Connector, J12	(1)
54	SJS5523	Connector, J5, 6	(2)
54	SJS5629	Connector, J7	(1)
55	SJT3213	Post, J2, 9, 11	(3)
55	SJT3319	Post, J1, 8, 10	(3)
55	SJT3415	Post, J12	(1)
55	SJT3511	Post, J5, 6	(2)
55	SJT3611	Post, J7	(1)
56	SJT785	Connector Pin	(10)
57	SJS5529	Connector, J5, 6	(2)
58	SJS5341	Connector	(2)
58	SJS5817	Connector	(2)
59	SJT3311	Post	(2)
59	SJT3805	Post	(2)
60	SJS5627	Socket, J3, 4	(2)

Ref. No.	Part No.	Description	QTY
SCREWS			
N1	XTB3+8B	Tapping, $\varnothing 3 \times 8$	(38)
N2	XTS3+8B	Tapping, $\varnothing 3 \times 8$	(4)
N3	XTN3+C6S	$\varnothing 3 \times 6$	(4)
N4	XTBS3+8BFZ1	Tapping with Detent, $\varnothing 3 \times 8$	(47)
N5	XTW3+8H	Tapping, $\varnothing 3 \times 8$	(14)
N6	XSS5+40FVS	$\varnothing 5 \times 40$	(8)
N7	XTB4+10B	Tapping, $\varnothing 4 \times 10$	(2)
N8	XTB4+8F	Tapping, $\varnothing 4 \times 8$	(8)
N9	XTW3+12J	Tapping, $\varnothing 3 \times 12$	(8)
N10	XTW3+8T	Tapping, $\varnothing 3 \times 8$	(4)
N11	XTB4+12FFZ	Tapping, $\varnothing 4 \times 12$	(4)
N12	XYN3+C6FZ	Voltage Selector	(2)
WASHERS			
N13	SNE98	Washer	(8)
N14	XWE5X12FVC	Washer	(8)
N15	XWA3B	Spring, $\varnothing 3$	(1)
N16	XWA7B	Washer, $\varnothing 7$	(8)
N17	SNE59-1	Washer	(1)
N18	XWC3B	External Toothed Lock, $\varnothing 3$	(1)
NUTS			
N20	XNSS12	Nut, $\varnothing 12$	(1)
N21	XNG3BS	Nut, $\varnothing 3$	(1)
N22	SNE4021	Nut	(2)
ACCESSORIES			
A1	SJP9215	Plug Adaptor	(1)
A2	SQF12712	Instruction Book	(1)
PACKING PARTS			
P1	SPP747	Polyethylene Bag	(1)
P2	SPH221	Sheet	(1)
P3	SPS4745	Pad, Bottom	(1)
P4	SPS4746	Pad, Upper	(1)
P5	SPG5681	Carton Box	(1)
P6	SPS4788	Pad, Front	(1)

Service Manual

Stereo DC Power Amplifier SE-A5MK2

[M], [MC]

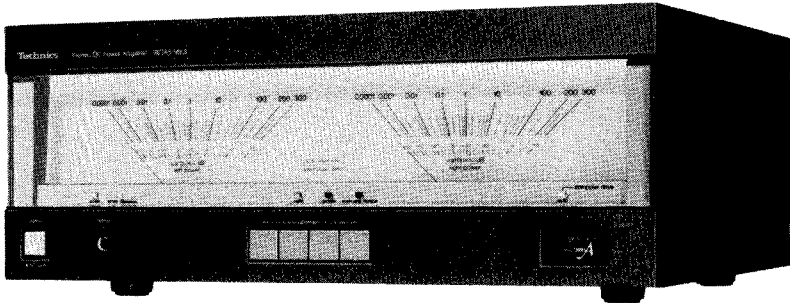

Areas

- * [M] is available in the U.S.A.
- * [MC] is available in Canada.

Specifications

Specifications are subject to change without notice for further improvement.
Weights and dimensions shown are approximate.

(IHF '78)

■ AMPLIFIER SECTION

Rated minimum sine wave RMS power output

20 Hz~20 kHz both channels driven

0.002% total harmonic distortion

150W per channel (8 ohms)

20 Hz~20 kHz both channels driven

0.002% total harmonic distortion

150W per channel (4 ohms)

1 kHz continuous power output

both channels driven

0.002% total harmonic distortion

150W per channel (8 ohms)

0.002% total harmonic distortion

150W per channel (4 ohms)

Dynamic headroom

1.5 dB (8 ohms)

3.6 dB (4 ohms)

Total harmonic distortion

rated power at 20 Hz~20 kHz 0.002% (8/4 ohms)

half power at 20 Hz~20 kHz 0.001% (8 ohms)

half power at 1 kHz 0.0005% (8 ohms)

Power bandwidth

both channels driven, -3 dB T.H.D. 0.01%

5 Hz~100 kHz (8 ohms)

Transient intermodulation distortion

unmeasurably small

SMPTE intermodulation distortion

0.002% (8 ohms)

Frequency response

DC~20 kHz (+0 dB, -0.1 dB)

DC~150 kHz (+0 dB, -3 dB)

Input sensitivity

90 mV (1V, IHF '66)

S/N (IHF, A)

102 dB (121 dB, IHF '66)

Residual hum and noise

0.13 mV

Input impedance

47 kilohms

Low frequency damping factor

100 (8 ohms)

50 (4 ohms)

Load impedance

MAIN or REMOTE

4~16 ohms

MAIN and REMOTE

8~16 ohms

Meter

reading range

0.0001W~300W

-60 dB~+5 dB

(logarithmic compression)

frequency response (reading accuracy)

20 Hz~20 kHz ± 2 dB (more than -50 dB)

20 Hz~20 kHz ± 3 dB (less than -50 dB)

■ GENERAL

Power consumption

720W, 900 VA

Power supply

AC 120V, 60 Hz

Dimensions (W×H×D)

430 × 178 × 416 mm

(16-15/16" × 7" × 16-3/8")

Weight

18.4 kg

(40.61 lb.)

Note:

Total harmonic distortion is measured by the digital spectrum analyzer (H.P. 3045 system).

Technics

Matsushita Engineering and
Service Company
50 Meadowland Parkway,
Secaucus, New Jersey 07094

Panasonic Hawaii Inc.
91-238 Kauhū St. Ewa Beach
P.O. Box 774
Honolulu, Hawaii 96808-0774

Panasonic Sales Company,
Division of Matsushita Electric
of Puerto Rico, Inc.
Ave. 65 De Infantería, KM 9.7
Victoria Industrial Park
Carolina, Puerto Rico 00630

Matsushita Electric
of Canada Limited
5770 Ambler Drive, Mississauga,
Ontario, L4W 2T3

SE-A5MK2

CONTENTS

	Page		Page
FEATURE	2	TERMINAL NAMES AND FUNCTION OF I _{CO}	
SAFETY PRECAUTION	2	CONTROL (MN1404STE)	14
LOCATION OF CONTROLS	3	DESCRIPTION OF I _{CO} CONTROL CIRCUIT	15, 16
PROTECTION CIRCUITRY	4	CURRENT DETECTION TYPE VOLTAGE	
BEFORE REPAIR AND ADJUSTMENT	4	CONTROL CIRCUIT	16
DISASSEMBLY INSTRUCTIONS	4, 5	BLOCK DIAGRAM	17, 18
MEASUREMENTS AND ADJUSTMENTS	6, 7	SCHEMATIC DIAGRAM	19 ~ 22
RESISTORS & CAPACITORS	7, 8	REPLACEMENT PARTS LIST	23
PRINTED CIRCUIT BOARDS	8 ~ 11	EXPLODED VIEWS	24 ~ 26
CIRCUIT BOARDS AND WIRING CONNECTION			
DIAGRAM (Top View)	12, 13		

FEATURE

- Power as high as 150W + 150W (8Ω/4Ω, 20Hz ~ 20kHz) suitable for the digital audio age.
- Technics original circuit – new class A system that has eliminated both switching and crossover distortions.
- Computer drive circuit that has eliminated transient crossover distortion in playback of music.
- Linear feedback circuit that has completely eliminated theoretical value distortion.
- Power linear circuit that does not allow distortion caused by change in speaker impedance.
- Dual-line speaker terminals that allow the comparison of sounds by one-push operation.
- Dual-line input terminals DC-Normal.

SAFETY PRECAUTION

1. Before servicing, unplug the power cord to prevent an electric shock.
2. When replacing parts, use only manufacturer's recommended components for safety.
3. Check the condition of the power cord. Replace if wear or damage is evident.
4. After servicing, be sure to restore the lead dress, insulation barriers, insulation papers, shields, etc.
5. Before returning the serviced equipment to the customer, be sure to make the following insulation resistance test to prevent the customer from being exposed to a shock hazard.

INSULATION RESISTANCE TEST

1. Unplug the power cord and short the two prongs of the plug with a jumper wire.
2. Turn on the power switch.
3. Measure the resistance value with ohmmeter between the jumpered AC plug and each exposed metal cabinet part, such as screwheads antenna, control shafts, handle brackets, etc. Equipment with antenna terminals should read between 3MΩ and 5.2MΩ to all exposed parts. (Fig. A) Equipment without antenna terminals should read approximately infinity to all exposed parts. (Fig. B)

Note: Some exposed parts may be isolated from the chassis by design. These will read infinity.

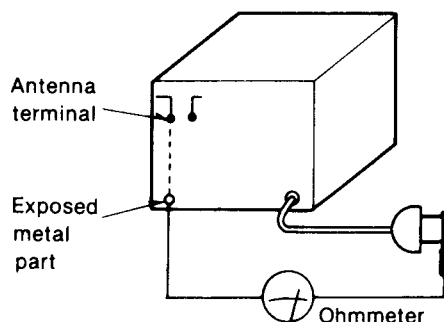

(Fig. A)

Resistance = 3MΩ—5.2MΩ

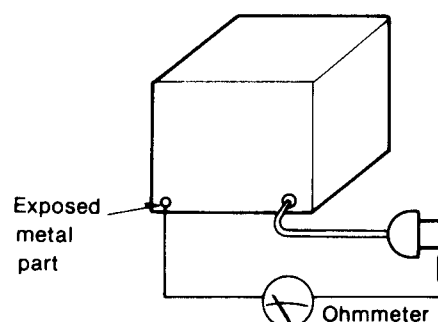

(Fig. B)

Resistance = Approx ∞

4. If the measurement is outside the specified limits, there is a possibility of a shock hazard. The equipment should be repaired and rechecked before it is returned to the customer.

LOCATION OF CONTROLS

• Front panel

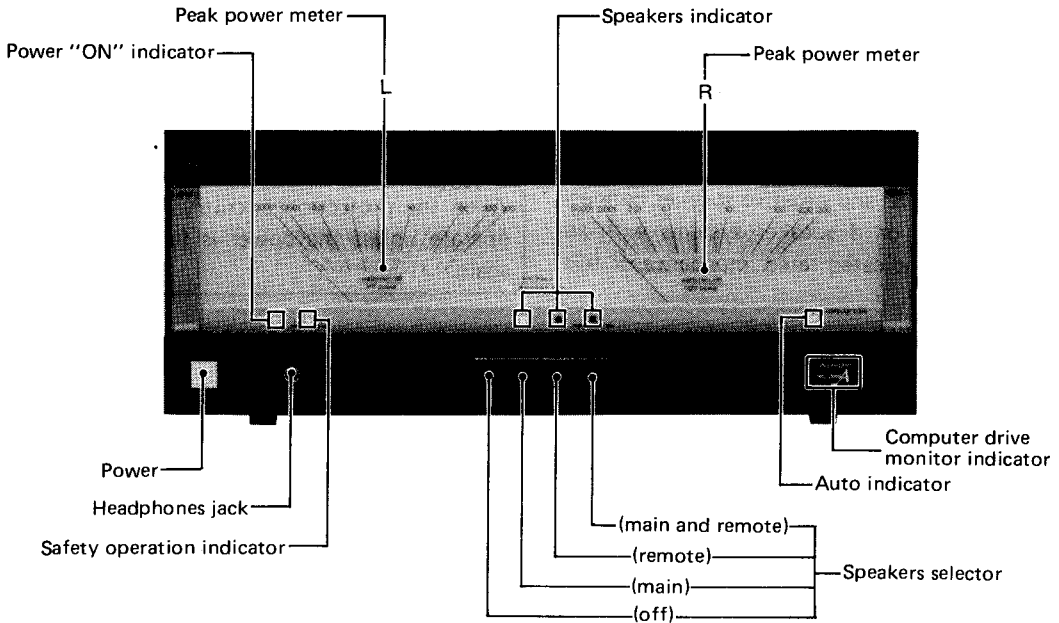

• Rear panel

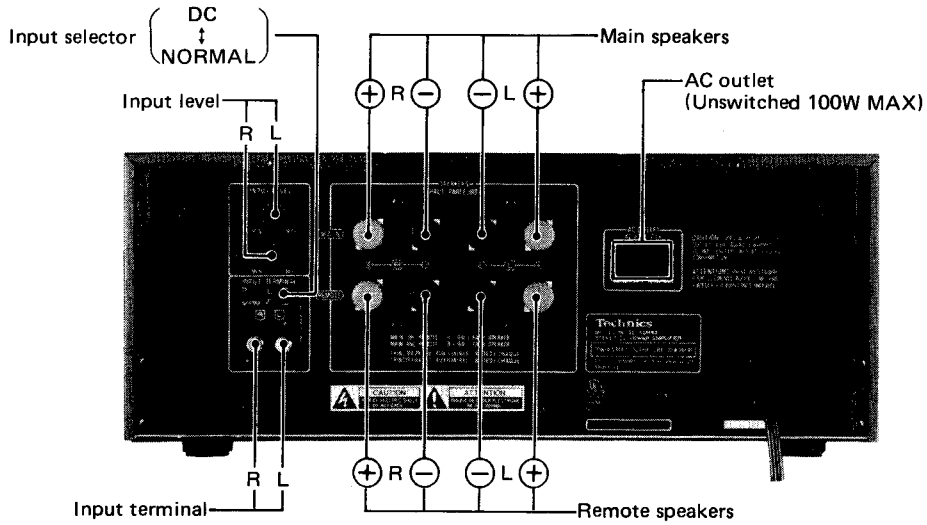

• Top view

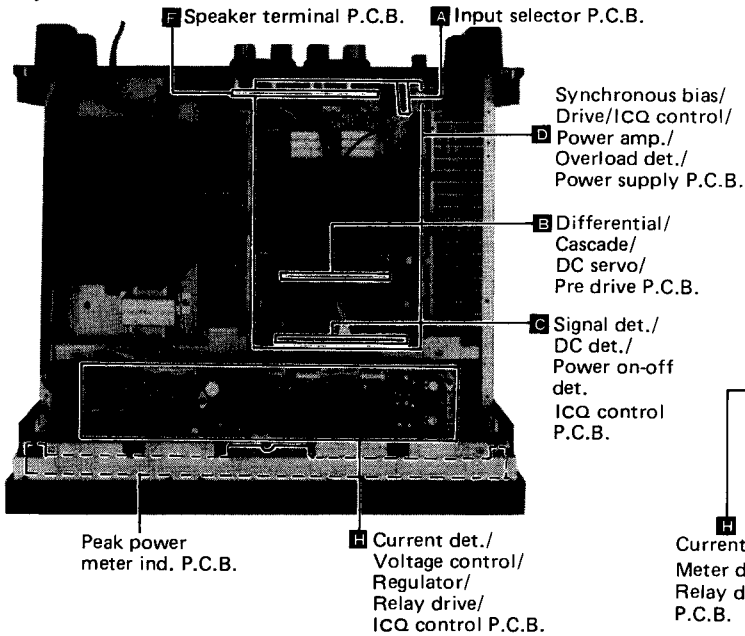

• Bottom view

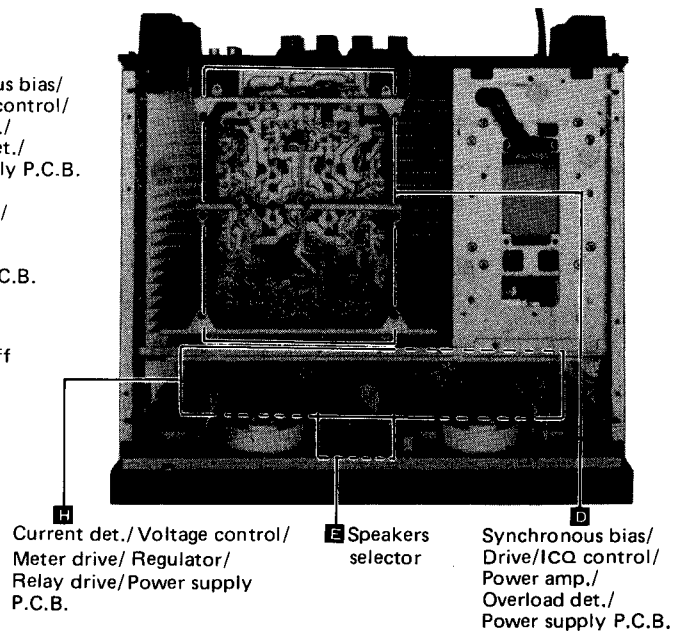

• Phono input capacitance is about 150pF.

SE-A5MK2

PROTECTION CIRCUITRY

The protection circuitry may have operated if either of the following conditions is noticed:

- No sound is heard when the power is turned on.
- Sound stops during a performance.

The function of this circuitry is to prevent circuitry damage if, for example, the positive and negative speaker connection wires are "shorted", or if speaker systems with an impedance less than the indicated rated impedance of this unit are used.

If this occurs, follow the procedure outlines below:

1. Turn off the power.
2. Determine the cause of the problem and correct it.
3. Turn on the power once again after one minute.

Note

When the protection circuitry functions, the unit will not operate unless the power is first turned off and then on again.

BEFORE REPAIR AND ADJUSTMENT

1. Turn off the power supply and short-circuit of power supply capacitors (C401 ~ C404, 8200 μ F) at resistance (about 10 Ω , 5W) in order to discharge the charged voltage. Do not short between C401 ~ C404 by screwdriver. It may damage the component.
2. Before turning on the power supply after completion of repair, slowly apply the primary voltage by using a power supply voltage controller to make sure that the consumed current at 120V, 60Hz in no-signal mode is 360mA ~ 820mA.

DISASSEMBLY INSTRUCTIONS

How to remove the cabinet

1. Remove the 10 setscrews (Fig. 1: ① ~ ⑩) of the cabinet.
2. Remove the cabinet in the direction of the arrow A in Fig. 1.

How to remove the front panel

1. Remove the 4 setscrews (Fig. 1: ⑪ ~ ⑭) of the front panel.
2. Remove the front panel in the direction of the arrow B in Fig. 1.

How to remove the bottom board

1. Remove the 9 setscrews (Fig. 2: ⑮ ~ ⑳) of the bottom board.

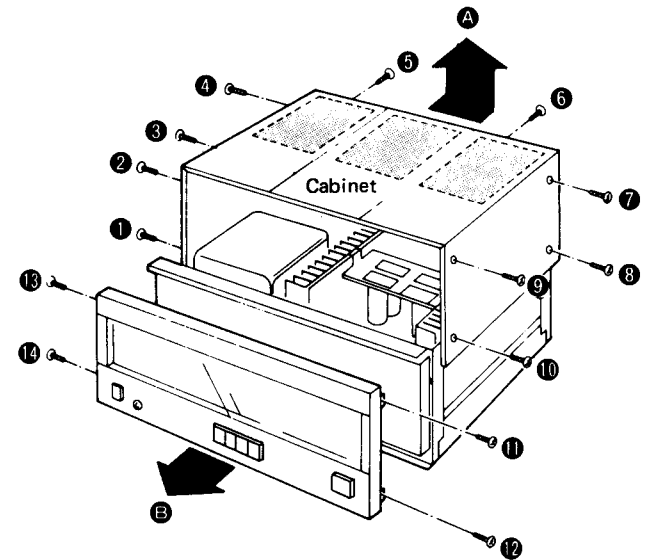

[Fig. 1]

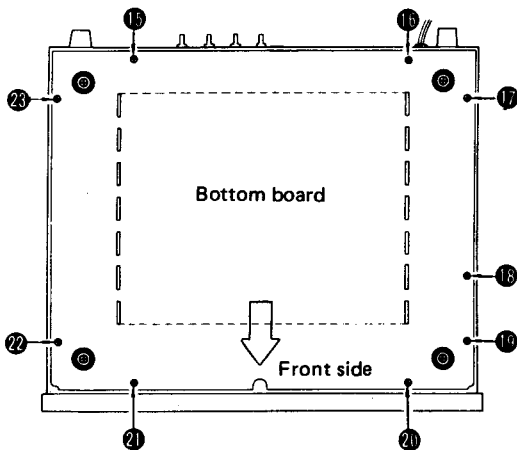

[Fig. 2]

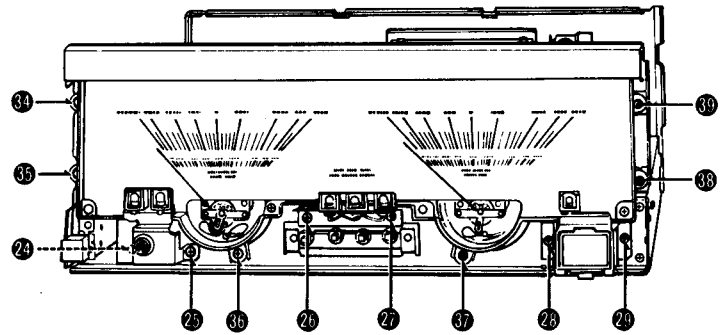

[Fig. 3]

● How to remove the peak power meter

1. Remove the cabinet and front panel.
2. Remove the 6 setscrews (Fig. 3: 24 ~ 29), and then detach the headphones jack, speakers indicator and computer drive indicator bracket from the chassis.
3. Remove the 2 setscrews (Fig. 4: 30 , 31) and then detach the meter cover.
4. Remove the 2 setscrews (Fig. 4: 32 , 33) of the detach the meter lamp P.C.B.
5. Remove the 6 setscrews (Fig. 3: 34 ~ 39) of the peak power meter.
6. Remove the 1 setscrew (Fig. 5: 40) and then detach the peak power meter.

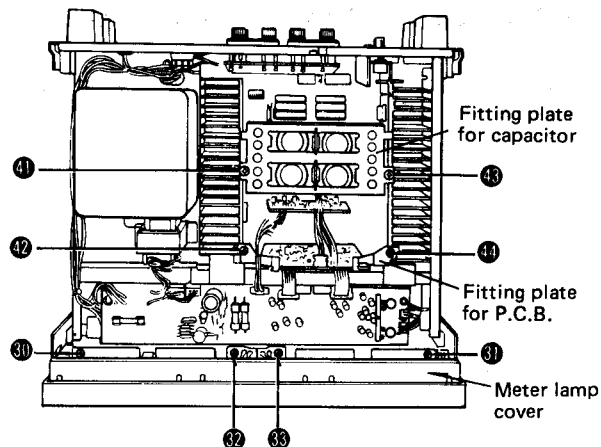

[Fig. 4]

● How to remove the power transistor

1. Remove the cabinet and bottom board.
2. Remove the 4 setscrews (Fig. 4: 41 ~ 44) and the detach the fitting plate.
3. Unsolder of power transistor. (R or L channel) [Fig. 6]
4. Remove the 3 setscrews (Fig. 6: 45 ~ 47 or 48 ~ 50) of the heat sink.
5. Remove the heat sink and power transistor.
6. When fitting it, apply silicone compound (SZZOL15) to both sides of mica plate. Also apply silicone compound (SZZOL15) to the heads of temperature compensation/bias control transistors (Q337, 338) and thermistor (TH501), then fit them to the heat sink with the retaining plate.

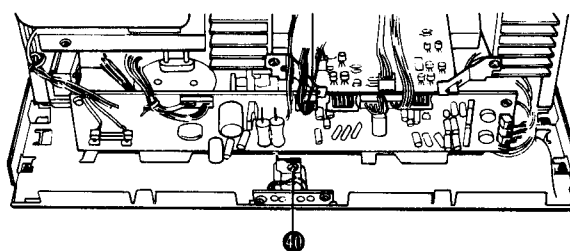

[Fig. 5]

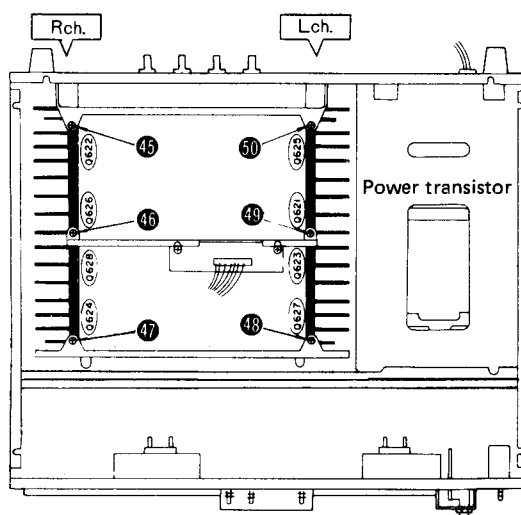

[Fig. 6]

MEASUREMENTS AND ADJUSTMENTS

1. Idling (ICQ) Adjustment (after repairing the main amp.) [Fig. 7]

- (1) After the repair, set the sound volume to maximal before turning on the power switch, and connect nothing to the speaker terminals.
- (2) Completely turn ICQ control (VR301, VR302) counter-clockwise.
- (3) Increase the voltage applied to the amplifier gradually from 0V by means of a power supply voltage controller, and make sure of the value in the Figure on page 4 before starting the adjustment.
- (4) Connect the DC electronic voltmeter to TP301 (+) and TP303 (-) (L ch) or TP302 (+) and TP304 (-) (R ch).
- (5) Adjust VR301 (L ch) or VR302 (R ch) so that the voltage is 4mV about 15 sec. after power switch "on".

In this set, ICQ is controlled by microcomputer, and ICQ a little more than the normal level is applied by "PREHEAT" for about 15 sec. after power ON. After that, the output level and transistor temperature are detected by "AUTO", thereby automatically controlling ICQ.

2. Peak Power Meter Level Adjustment (after repairing the meter amp circuit or replacing the peak power meter.)

- (1) Set the input level adjustment to the maximal position.
- (2) Connect a dummy resistor of 8Ω or a speaker of 8Ω impedance and AC voltmeter to the speaker terminal.
- (3) Apply 1kHz sine wave to the AUX/CD/VIDEO terminal and adjust the input so that the output to the speaker terminal is 28.3V.
- (4) Adjust both channels of VR101 (L ch) and VR102 (R ch) so that the meter indicating is 100W.

• Adjustment point

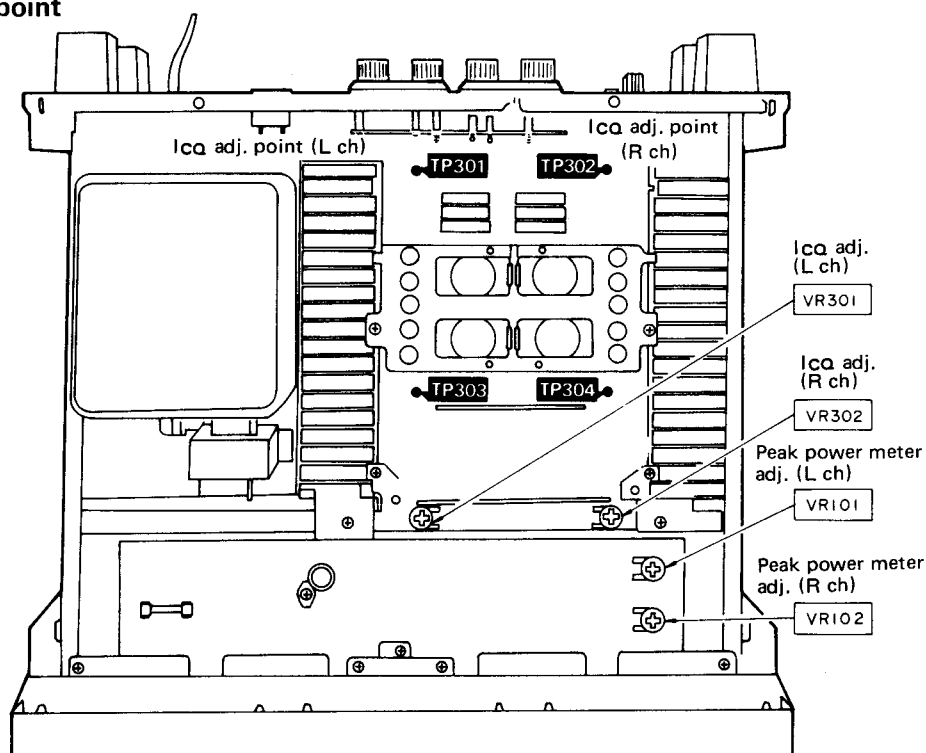

3. Check of Muting Circuit During Power "on" - "off" Operation.

- (1) Connect 8Ω load and AC voltmeter to the speaker terminal.
- (2) Set the input level adjustment to the maximal position.
- (3) Apply 1kHz sine wave, 0.5V to the speaker terminal.
- (4) Make sure that output is delivered about 3 ~ 5 sec. after turning the power switch "on".
- (5) Output should immediately be gone when power switch is turned "off".

4. Check of DC Detection Circuit

- (1) Set the input level adjustment to the maximal position.
- (2) Apply DC voltage +1V (to L ch), -1V (to R ch) to the DC input terminal.
- (3) Make sure
 - relay is off.
 - "auto" indicator "on" goes out.
 - "safety operation" indicator blinks.

5. Check of Overload Detection and Protection Circuit

- (1) Connect 8Ω (resistor or speaker) and AC voltmeter to the main speaker terminal.
- (2) Main speaker selector is "on" position.
- (3) Connect 0.33Ω (5W) resistor to the remote speaker terminal.
- (4) Apply output signal of about 5V at 1kHz to input terminal.
- (5) Make sure that no output is delivered when remote speaker switch is set to "on".

When the protection circuitry functions, the unit will not operate unless the power is first turned off and then on again.

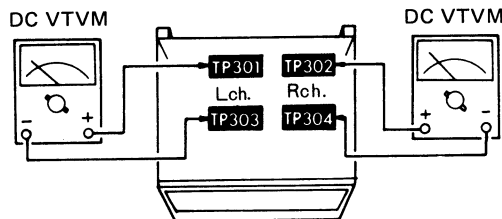

[Fig. 7] Idling (IcQ) Adjustment

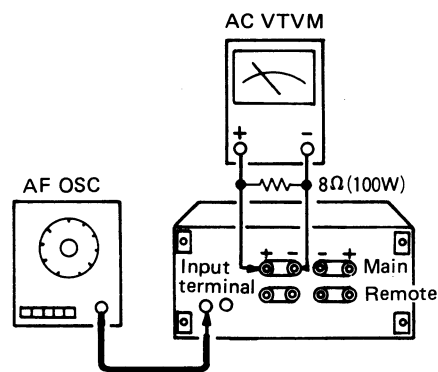

[Fig. 8] Peak power meter adjustment

RESISTORS & CAPACITORS

- Notes:**
- Part numbers are indicated on most mechanical parts. Please use this part number for parts orders.
 - Important safety notice: Components identified by Δ mark have special characteristics important for safety. When replacing any of these components use only manufacturer's specified parts.

- The "S" mark is service standard parts and may differ from production parts.
- The unit of resistance is Ω (ohm),
K = 1000 Ω , M = 1000k Ω .
- The unit of capacitance is μ F (microfarad).
P = 10⁻⁶ μ F
- Bracketed indications in Ref. No. columns specify the area. Parts without these indications can be used for all areas.

Resistor Type	Wattage	Tolerance
ERD : Carbon	10 : 1/8W	J : \pm 5%
ERG : Metal Oxide	25 : 1/4W	G : \pm 5%
ERO : Metal Film	2 : 2W	
ERF : Non-flammable	S1 : 1/2W	
	3 : 3W	

ERD10TLJ □□□ → Chip type carbon

Capacitor Type	Voltage		Tolerance
	ECEA Type	Other	
ECEA : Electrolytic	0J : 6.3V	1H : 50V	D : \pm 0.5pF
ECCD : Ceramic	1A : 10V	KC : 400V AC	K : \pm 10%
ECKD : Ceramic	1C : 16V	2H : 500V	Z : +80%, -20%
ECQM : Polyester	1E : 25V		P : +100%, -0%
ECET : Electrolytic	1H : 50V		
ECEA...N : Non Polar Electrolytic	50 : 50V		
	25 : 25V		
	45 : 45V		
	2A : 100V		

RESISTORS

Ref. No.	Part No.	Value	Ref. No.	Part No.	Value	Ref. No.	Part No.	Value	Ref. No.	Part No.	Value
R21, 22	ERD10TLJ223U	22K	R301, 302	(S) ERD25FJ221	220	R363, 364	(S) Δ ERD25FJ271	270	R515	Δ ERDS1FJ391	390
R23, 24	ERD10TLJ223U	22K	R305, 306	(S) ERD25FJ272	2.7K	R365, 366	(S) Δ ERD25FJ2R2	2.2	R516	Δ ERDS1FJ331	330
R25, 26	ERD10TLJ333U	33K	R307, 308	(S) ERD25FJ392	3.9K	R367, 368	(S) Δ ERD25FJ2R2	2.2	R517	Δ ERDS1FJ391	390
R27, 28	ERD10TLJ123U	12K	R309, 310	(S) ERD25FJ392	3.9K	R369, 370	(S) Δ ERD25FJ2R2	2.2	R518	(S) Δ ERD25FJ181	180
R29	(S) ERD25FJ472	4.7K	R311, 312	(S) ERD25FJ393	39K	R371, 372	(S) Δ ERD25FJ2R2	2.2	R519	(S) Δ ERD25FJ100	10
R30, 31	ERD10TLJ103U	10K	R313, 314	(S) ERD25FJ103	10K	R373, 374	Δ ERF3RKR33	0.33	R520	(S) ERD25TJ683	68K
R32	(S) ERD25FJ103	10K	R315, 316	(S) ERD25FJ330	33	R375, 376	Δ ERF3RKR33	0.33	R601, 602	(S) Δ ERD25FJ151	150
R33	ERD10TLJ102U	1K	R317, 318	(S) ERD25FJ393	39K	R377, 378	Δ ERF3RKR33	0.33	R603	(S) ERD25FJ222	2.2K
R34, 35	ERD10TLJ104U	100K	R319, 320	(S) ERD25FJ103	10K	R379, 380	Δ ERF3RKR33	0.33	R604	(S) Δ ERD25FJ151	150
R36	ERD10TLJ333U	33K	R321, 322	(S) ERD25FJ561	560	R381, 382	(S) ERD25TJ224	220K	R605	(S) ERD25TJ333	33K
R37, 38	(S) ERD25FJ822	8.2K	R323, 324	(S) ERD25FJ471	470	R383, 384	(S) ERD25TJ224	220K	R606	(S) ERD25TJ223	22K
R39	(S) ERD25TJ394	390K	R325, 326	(S) ERD25FJ151	150	R385, 386	(S) Δ ERD25FJ3R3	3.3	R607, 608	(S) ERG3ANJ331	330
R40	(S) ERD25TJ223	22K	R327, 328	(S) ERD25FJ151	150	R387, 388	(S) Δ ERD25FJ3R3	3.3	R609	(S) Δ ERD25FJ181	180
R41, 42	ERD10TLJ223U	22K	R329, 330	(S) ERD25FJ102	1K	R389, 390	(S) Δ ERD25FJ100	10	R701, 702	(S) Δ ERD25FJ331	330
R43	ERD10TLJ223U	22K	R331, 332	(S) ERD25FJ821	820	R391, 392	(S) ERG2ANJ100	10	R703, 704	(S) Δ ERD25FJ681	680
R44, 45	(S) ERD25TJ223	22K	R333, 334	(S) ERD25FJ102	1K	R393, 394	(S) Δ ERD25FJ100	10	R705, 706	(S) ERD25TJ124	120K
R46	ERD10TLJ392U	3.9K	R335, 336	(S) ERD25FJ102	1K	R395, 396	(S) Δ ERD25FJ561	560	R707, 708	(S) ERD25FJ562	5.6K
R47	(S) ERD25FJ472	4.7K	R337, 338	(S) Δ ERD25FJ681	680	R397, 398	(S) Δ ERD25FJ222	2.2K	R709, 710	(S) ERD25TJ333	33K
R48	ERD10TLJ392U	3.9K	R339, 340	(S) Δ ERD25FJ681	680	R401, 402	(S) ERD2FCG5R6	5.6	R711, 712	(S) ERD25TJ333	33K
R49	ERD10TLJ153U	15K	R341, 342	(S) Δ ERD25FJ101	100	R403, 404	(S) ERD2FCG5R6	5.6	R713, 714	(S) ERD25TJ333	33K
R50	ERD10TLJ103U	10K	R343, 344	(S) Δ ERD25FJ101	100	R405, 406	(S) ERD25FJ472	4.7K	R715, 716	Δ ERDS1FJ102	1K
R101, 102	ERO25CKF1962	19.6K	R345, 346	(S) Δ ERD25FJ101	100	R501, 502	(S) Δ ERD25FJ222	2.2K	R717, 718	Δ ERDS1FJ102	1K
R103, 104	(S) ERD25TJ824	820K	R347, 348	(S) Δ ERD25FJ101	100	R503, 504	(S) Δ ERD25FJ681	680	R801, 802	(S) ERD25FJ103	10K
R105, 106	(S) ERD25TJ104	100K	R349, 350	(S) Δ ERD25FJ102	1K	R505, 506	(S) Δ ERD25FJ331	330	R803, 804	(S) ERD25TJ224	220K
R107, 108	(S) ERD25FJ102	1K	R351, 352	(S) ERD25FJ102	1K	R507, 508	(S) ERD25TJ183	18K	R805, 806	(S) ERD25TJ224	220K
R109, 110	(S) ERD25FJ471	470	R353, 354	(S) ERD25TJ333	33K	R509	(S) ERD25TJ183	18K	R851, 852	(S) ERD25TJ393	39K
R111, 112	(S) ERD25FJ221	220	R355, 356	(S) ERD25TJ104	100K	R511	(S) ERD25TJ104	100K	R853, 854	(S) ERD25FJ122	1.2K
R113, 114	(S) ERD25FJ222	2.2K	R357, 358	(S) ERD25TJ104	100K	R512	(S) ERD25TJ224	220K			
R201, 202	(S) ERD25FJ222	2.2K	R359, 360	(S) ERD25TJ223	22K	R513	(S) ERD25TJ223	22K			
R203, 204	(S) ERD25TJ224	220K	R361, 362	(S) ERD25TJ823	82K	R514	(S) ERD25FJ472	4.7K			

SE-A5MK2

PRINTED CIRCUIT BOARDS PEAK POWER METER P.C.B.

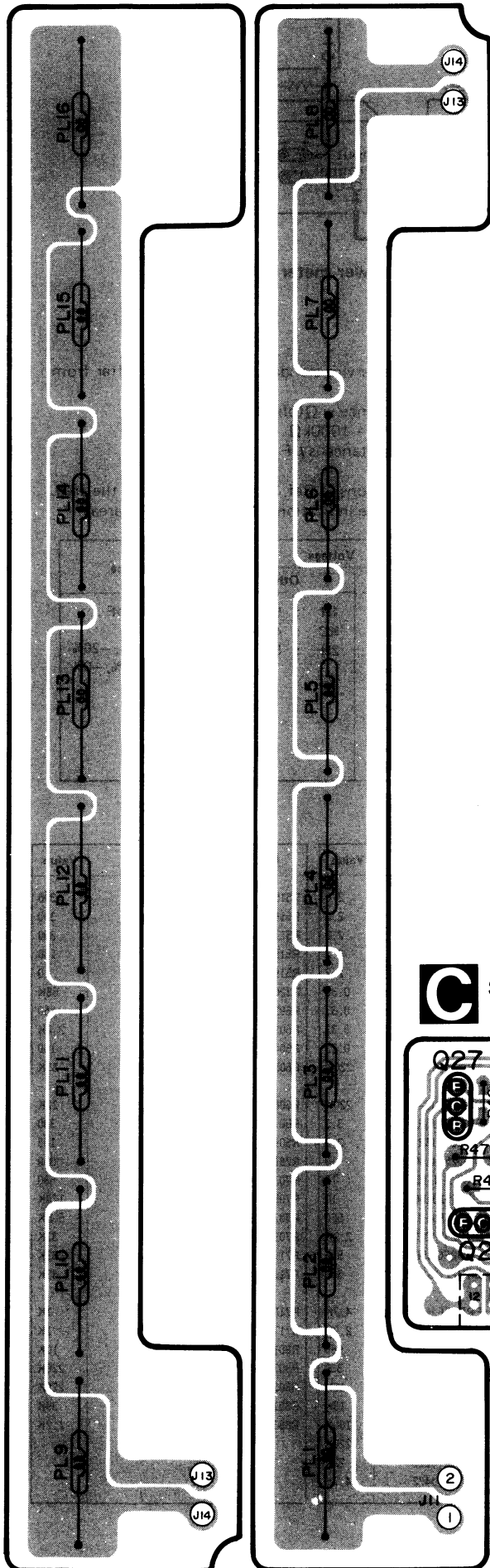

● CAPACITORS

Ref. No.	Part No.	Value
C21, 22	ECEA1EU3R3	3.3
C23	ECEA1CU100	10
C24	ECEA1CU101	100
C25	ECEA1HUR47	0.47
C26	Ⓢ ECCD1H121K	120P
C27	ECEA0JU101	100
C28	Ⓢ ECKD1H223ZF	0.022
C101, 102	△ ECEA1EN3R3S	3.3
C103, 104	ECEA1HUR47	0.47
C105, 106	ECEA1HUR47	0.47
C107, 108	ECEA1CU470	47
C201, 202	△ ECEA1HN2R2S	2.2
C203, 204	Ⓢ ECCD1H181K	180P
C301, 302	Ⓢ ECCD1H101K	100P
C303, 304	Ⓢ ECKD1H681KB	680P
C307, 308	Ⓢ ECCD2H070D	7P
C309, 310	Ⓢ ECCD2H070D	7P
C311, 312	Ⓢ ECCD2H270K	27P
C313, 314	Ⓢ ECCD2H270K	27P
C315, 316	ECEA1HU330	33
C317, 318	ECEA2AU010	1
C321, 322	ECEA1CU100	10
C323, 324	ECEA1EU4R7	4.7
C325, 326	Ⓢ△ ECEA25N4R7	4.7
C327, 378	Ⓢ ECCD1H120KC	12P
C331, 332	Ⓢ ECKD1H681KB	680P
C333, 334	Ⓢ ECKD1H681KB	680P
C339, 340	ECQM1H473KV	0.047
C401, 402	ECET1KV822Z	8200
C403, 404	ECET1KV822Z	8200
C405	ECEA1VU102	1000
C406	ECEA1VU471	470
C407, 408	ECEA1EU330	33
C409	ECEA1EU3R3	3.3
C410	Ⓢ ECKD1H103ZF	0.01
C501	ECEA1HU010	1
C502	ECEA0JU470	47
C503	Ⓢ ECKD1H103ZF	0.01
C504	ECEA1HU010	1
C701, 702	ECEA1CU100	10
C703, 704	Ⓢ ECKD1H103ZF	0.01
C801, 802	Ⓢ ECCD1H101K	100P
C803, 804	Ⓢ ECKD1H221KB	220P
C805, 806	Ⓢ ECKD1H221KB	220P
C1001	△ ECKDKC103PF2	0.01

C SIGNAL DET./DC DET./POWER ON-OFF DET./ Icq CONTROL P.C.B.

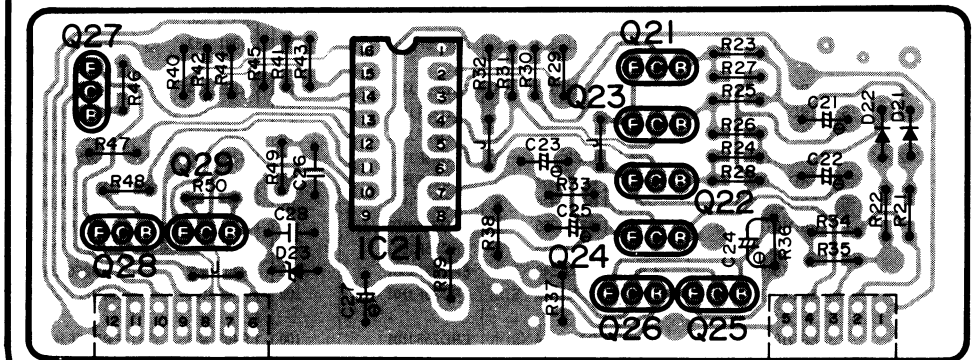

G HEADPHONES TERMINAL P.C.B.

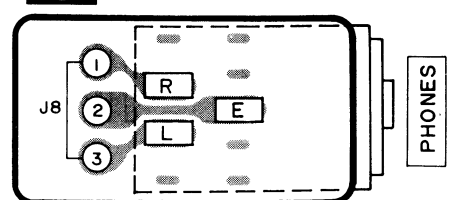

POWER SUPPLY P.C.B.

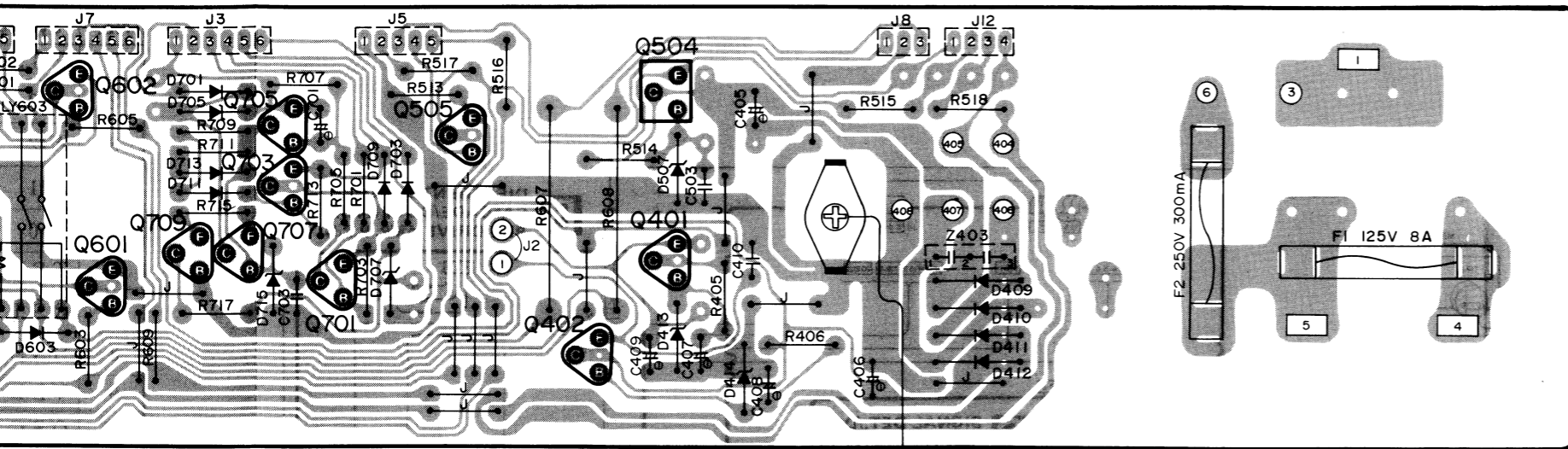

LOAD DET./POWER SUPPLY P.C.B.

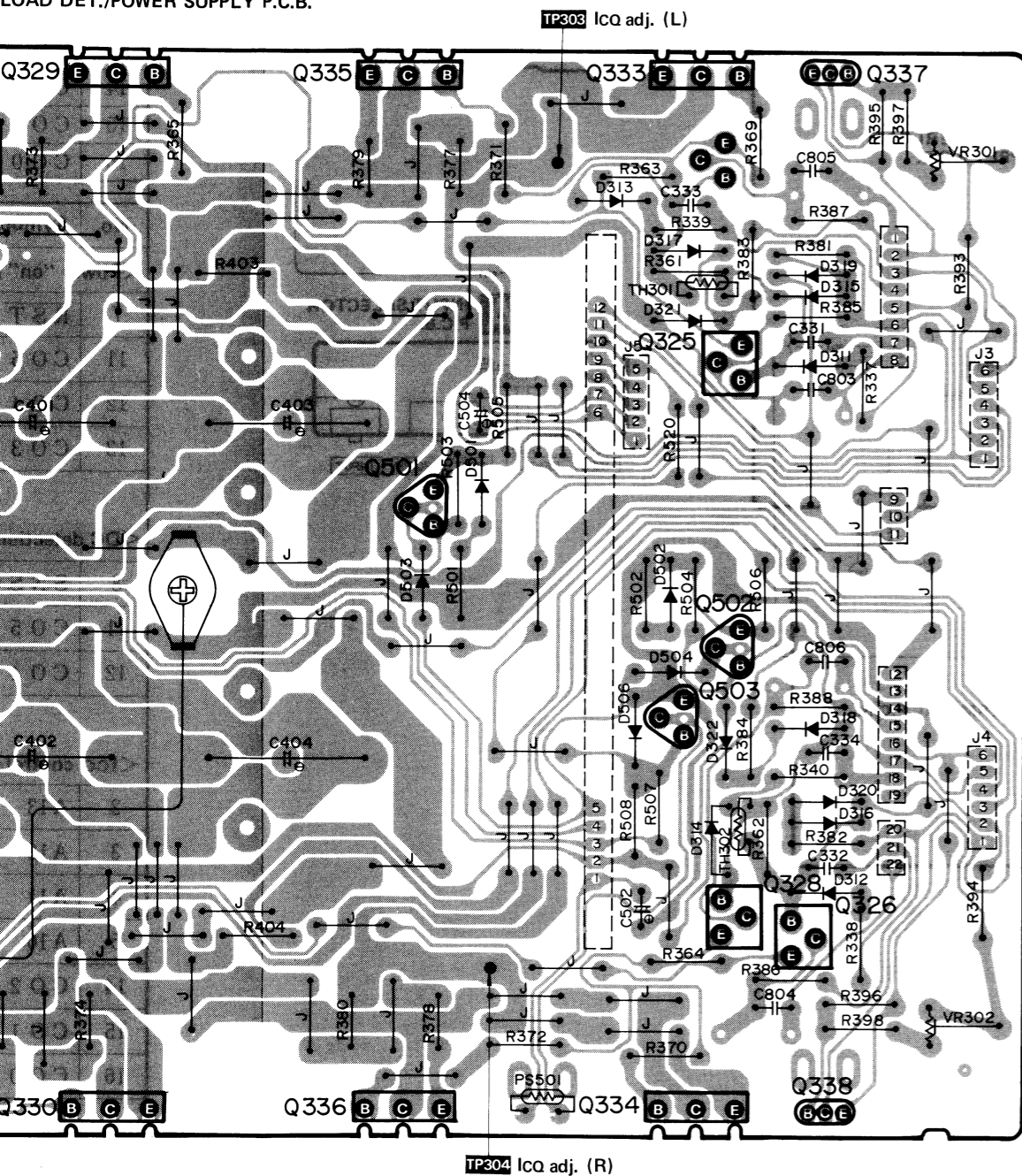

DIFFERENTIAL AMP/CASCADE/DC SERVO/
PRE DRIVE AMP. P.C.B.

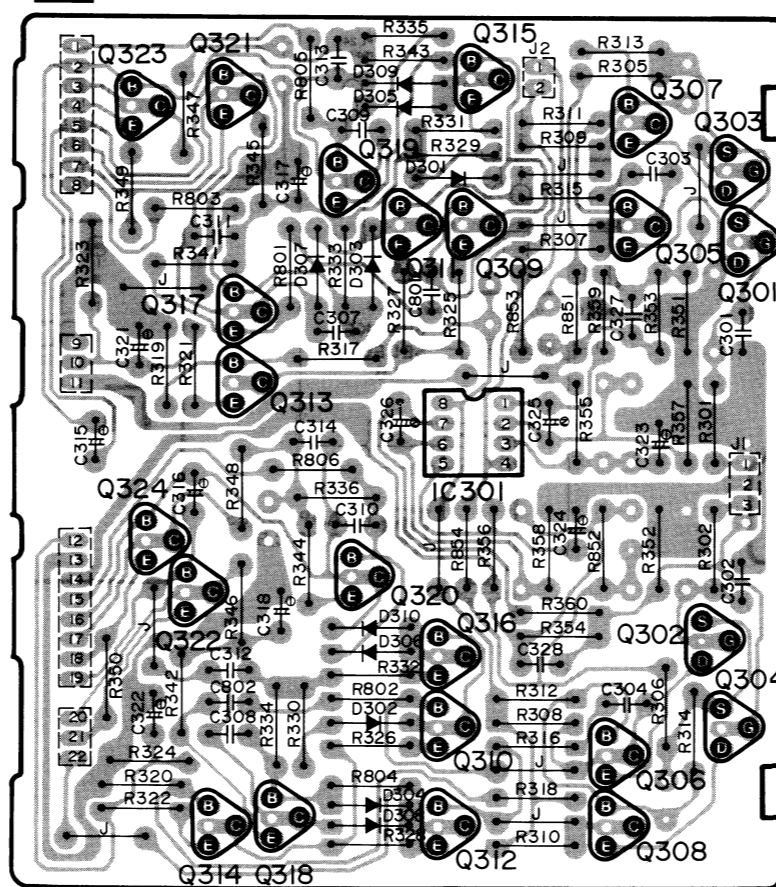

INPUT SELECTOR P.C.B.

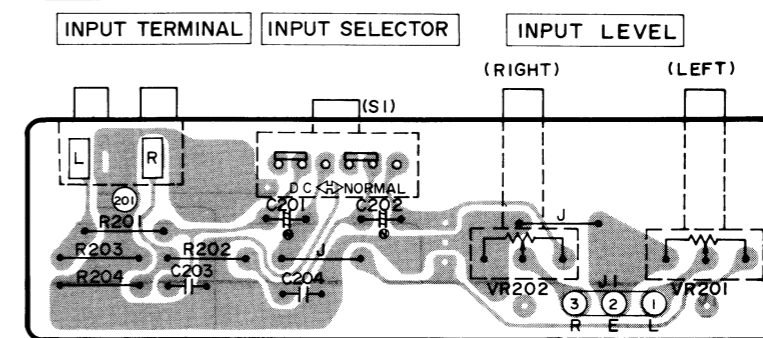

SPEAKERS SELECTOR P.C.B.

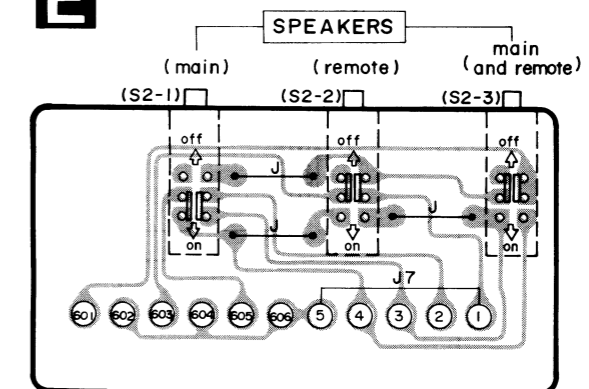

SPEAKER TERMINAL P.C.B.

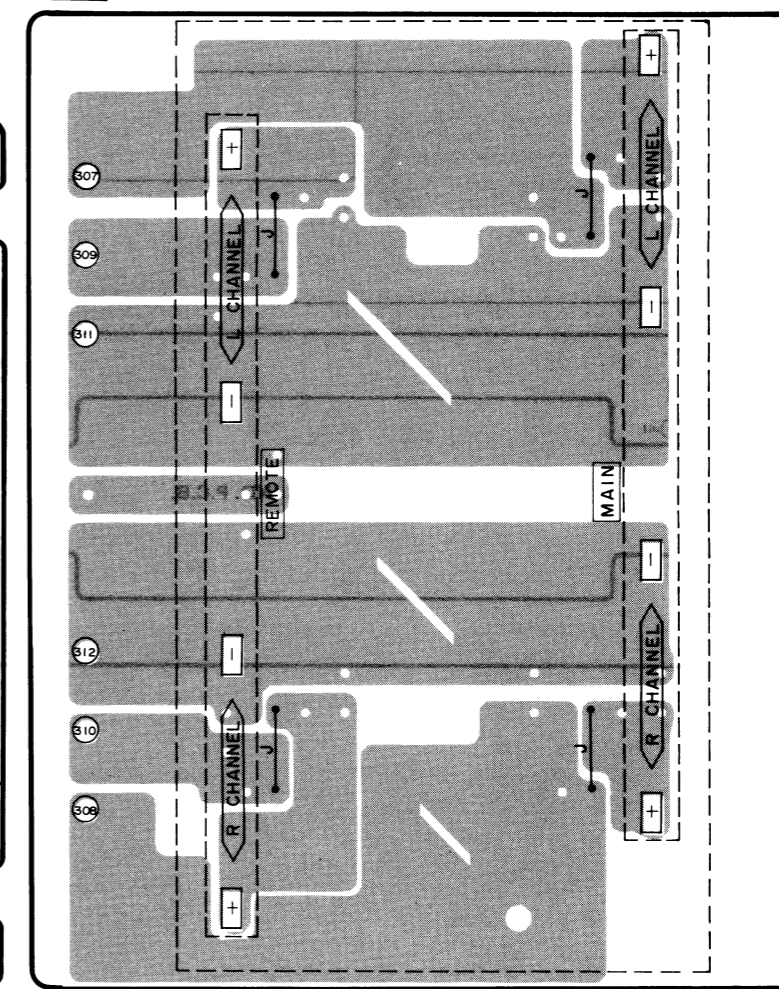

CIRCUIT BOARDS AND WIRING CONNECTION DIAGRAM (Top View)

TERMINAL

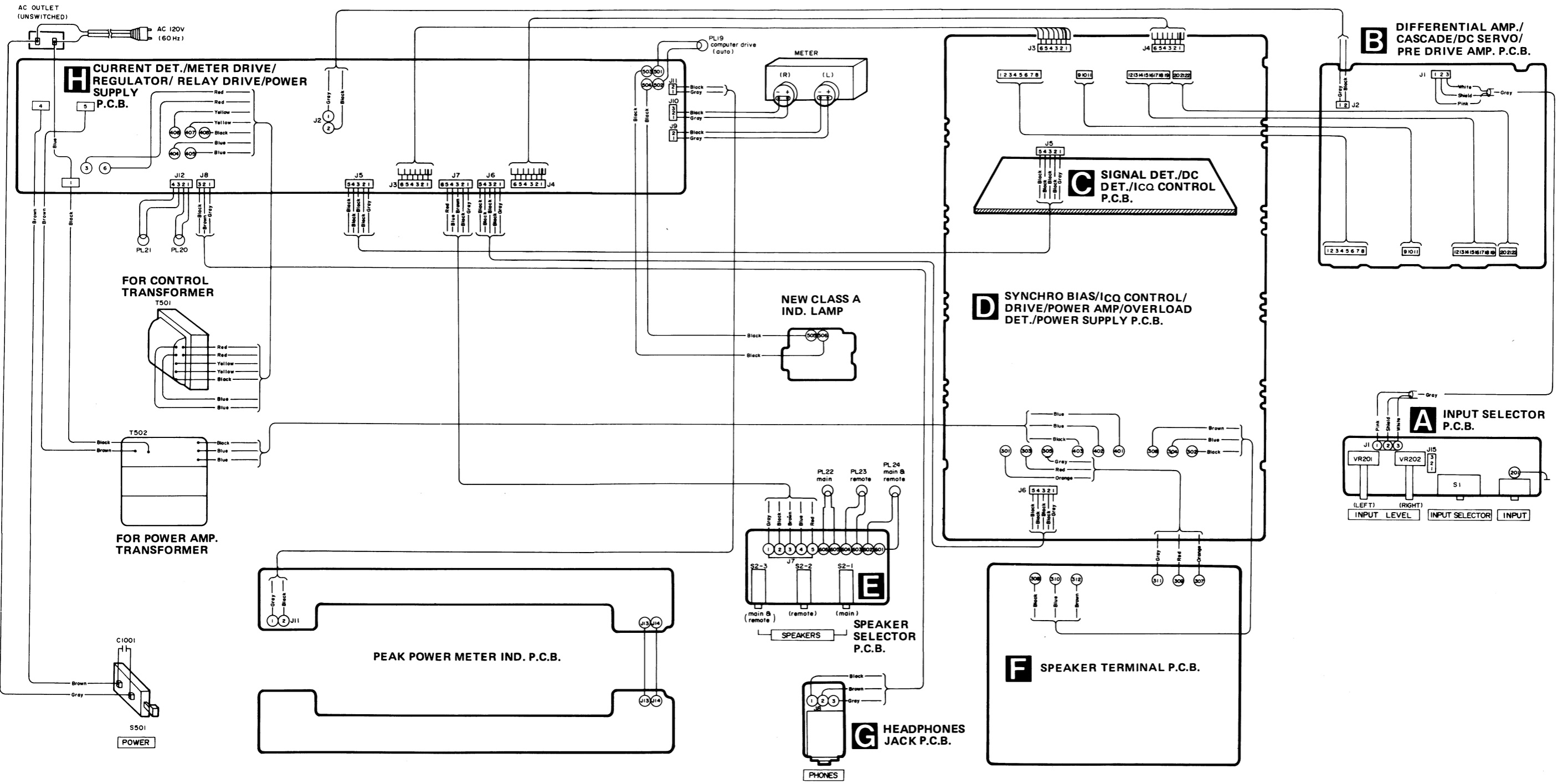

No.	Symbol
1	VSS
2	A13
3	A12
4	A11
5	A10
6	TST
7	RST
8	SNSO
9	VDD
10	OSC
11	CO5
12	CO4
13	CO3
14	CO2
15	CO1
16	CO0

No.	Symbol
<Power "on" mode	
7	RST
11	CO5
12	CO4
13	CO3

<DC detection or	
8	SNSO
11	CO5
12	CO4

<ICQ control oper	
2	A13
3	A12
4	A11
5	A10
14	CO2
15	CO1
16	CO0

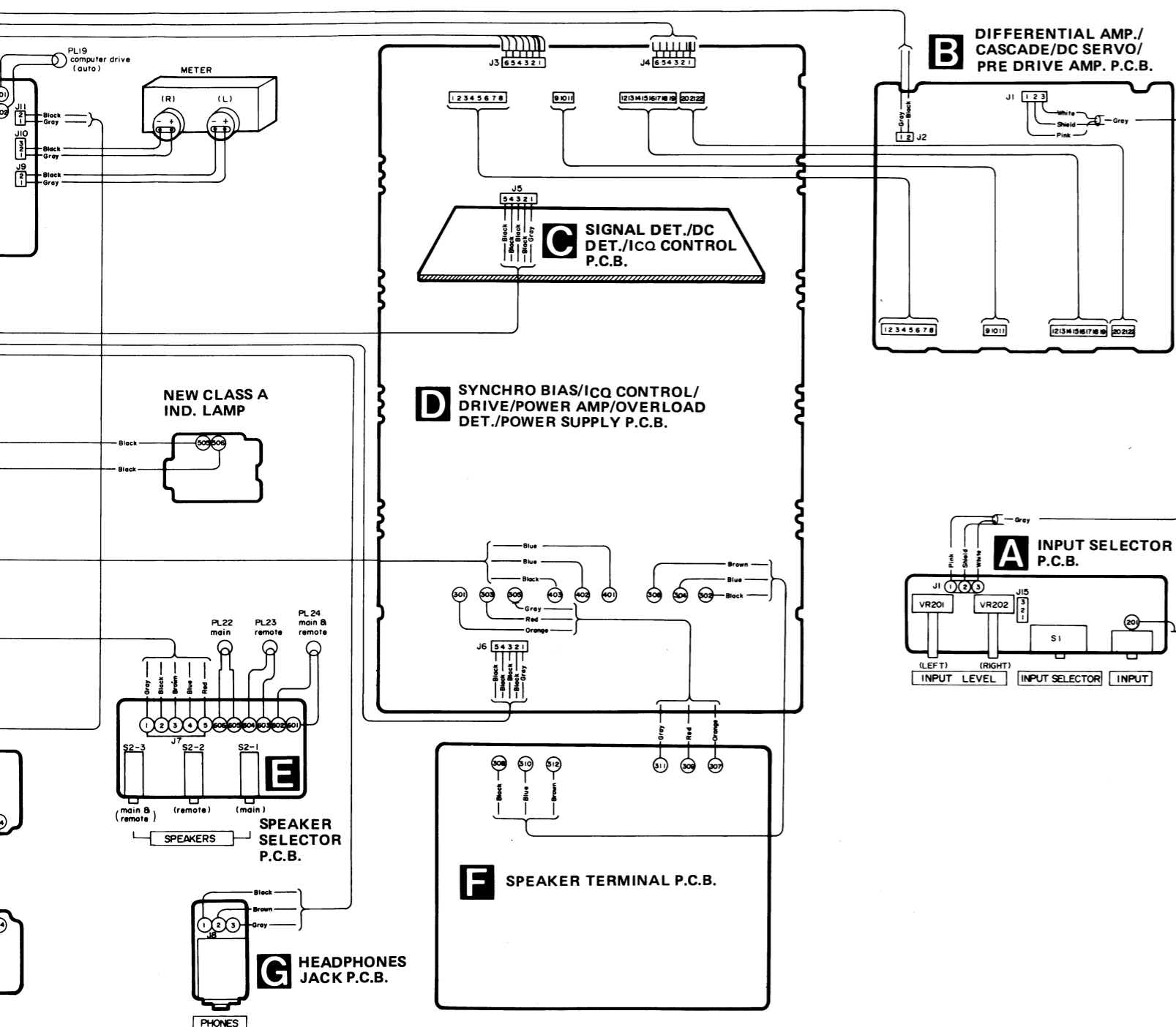

■ TERMINAL NAMES AND FUNCTION OF ICQ CONTROL (MN1404STE)

No.	Symbol	Name of block	Description of terminal
1	VSS	Power supply input terminal	Grounded. (0V)
2	A13	Input port A	Temperature detection circuit. When 60°C (140°F) sensor of power amplifier operates, "H" is put in causing the outputs of terminals 14 ~ 16 to go "H".
3	A12		When effective output 5V signal sensor of L-ch power amplifier operates, "L" is put in causing the output of terminal 14 to go "H".
4	A11		When effective output 2V signal sensors of both-ch power amplifiers operate, "L" is put in causing the output of terminal 15 to go "H".
5	A10		When effective output 5V signal sensor of R-ch power amplifier operates, "L" is put in causing the output of terminal 16 to go "H".
6	TST	Test input terminal	Terminal for testing LSI. (Ground)
7	RST	Reset input terminal	All outputs are cleared or reset with input at "L". (It is connected to power supply circuit)
8	SNSO	Sensor input terminal	When overload detection circuit of power amplifier output operates, "H" is put in causing the output of terminal 12 to go "L".
9	VDD	Power supply input terminal	Apply 5V.
10	OSC	OSC input terminal	Clock signal (about 415kHz) can be obtained by internal oscillation circuit.
11	CO5	Output port C	When protection circuit operates, "H" and "L" outputs are repeated and "safety operation" indicator blinks.
12	CO4		Output relay and meter relay turn ON with "H" output.
13	CO3		Indicator "auto" lights up at "H".
14	CO2		ICQ control signal is emitted from A input port (temp. sensor, signal sensor). ("H" output)
15	CO1		
16	CO0		

No. Symbol Time chart

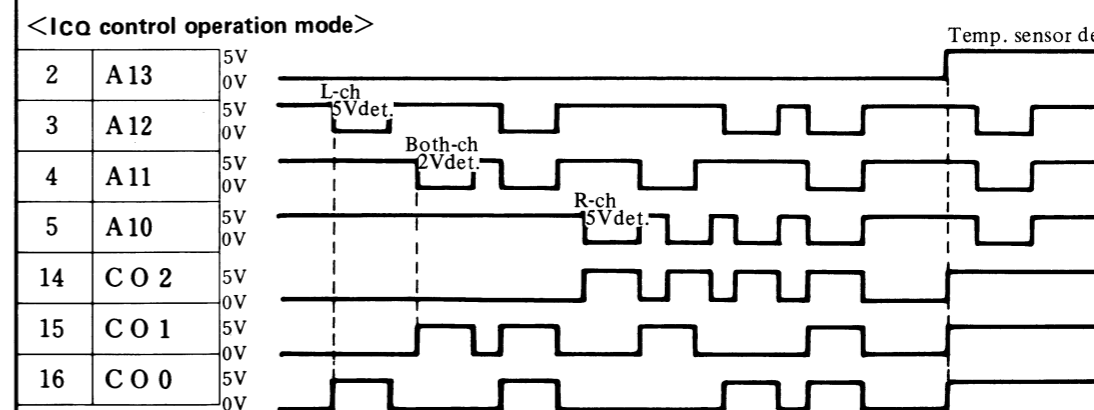
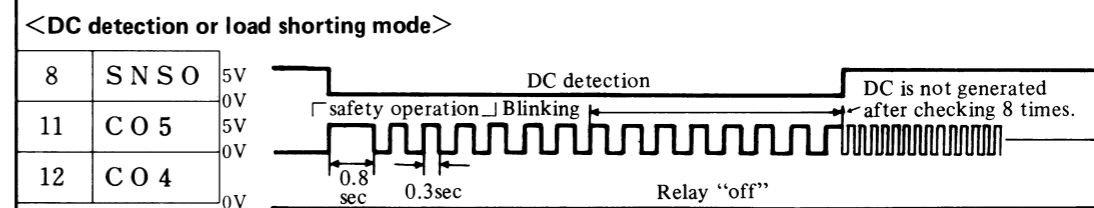
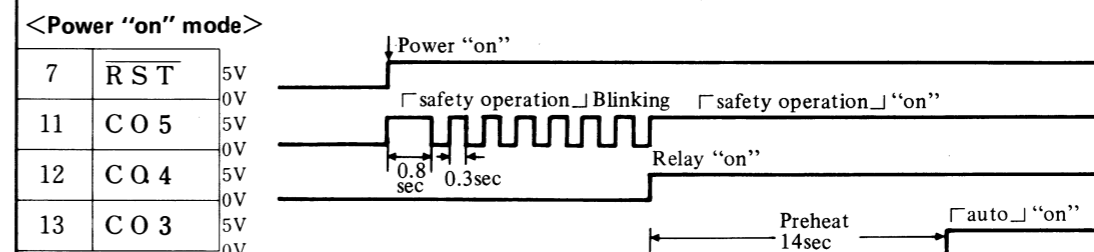

DESCRIPTION OF I_{CQ} CONTROL CIRCUIT

Signal and temperature detection (See Fig. 9.)

1. Music signal of power amplifier is applied to IC21 terminal ③ (⑤) of D21 (D22) and Q21 (Q22). When the signal rectified by D21 (D22) and C21 (C22) exceeds about 5V, Q21 (Q22) turns "on" causing "L" input to be applied to IC21 terminal ③ (⑤). Also, when the signal is over 2V, Q23 turns "on" causing "L" put to be applied to IC21 terminal ④. As "L" is put into IC21 terminals ③ ~ ⑤, the outputs of terminals ⑭ ~ ⑯ go "H" to make ICQ control.
2. PS501 is the thermistor (positor) for heat sink temperature detection which detects the temperature [60°C (140°F)] of the heat sink. When the heat sink temperature becomes [60°C (140°F)], the resistance of PS501 increases causing "H" input to be applied to IC21 terminal ②. As "H" is put into IC21 terminal ②, the outputs of IC21 terminals ⑭ ~ ⑯ go "H" to make ICQ control.

Overload detection circuit (See Fig. 9.)

When speaker terminals are shorted, great current flows to R503 (R504) causing the base potential of Q501 (Q502) (overload detection circuit) to increase, then the base voltage of Q501 (Q502) rises and Q501 (Q502) turns "on". With Q501 (Q502) turned ON, both Q25 and Q26 turn "on" causing "L" input to be applied to IC21 terminal ⑧. Then, "L" output is applied to IC21 terminals ⑫ and ⑬. As terminal ⑫ goes "L", Q501, Q601 and Q602 turn "off" causing RLY601 ~ 603 to turn "off". When terminal ⑬ goes "L", Q27 turns "off" causing "auto" indicator to turn "off". Also, "H" and "L" outputs are delivered from terminal ⑪ at 0.1 sec. intervals, then the "safety operation" indicator blinks.

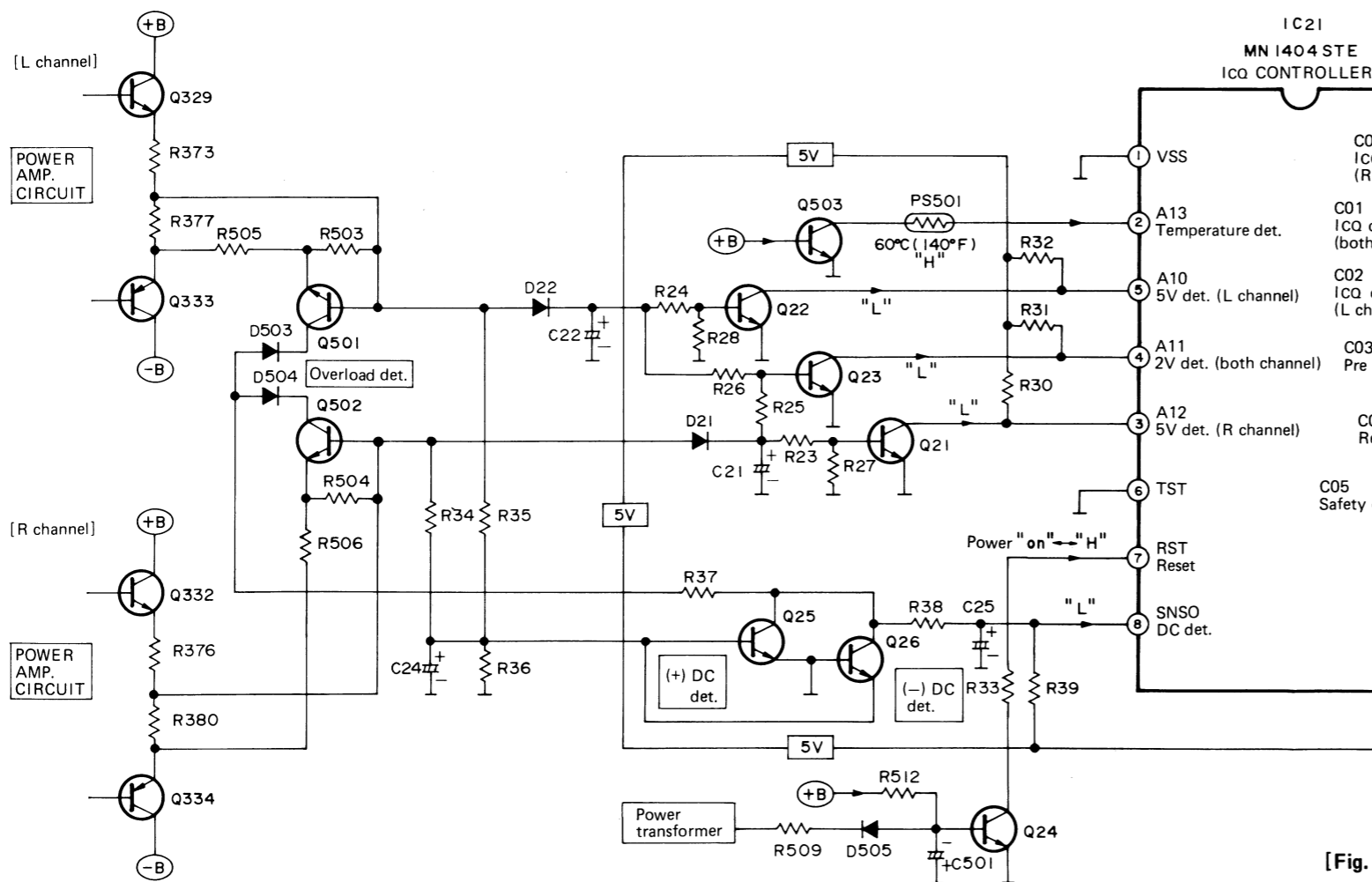

CURRENT DETECTION TYPE VOLTAGE CONTROL CIRCUIT

- ① With 4Ω speaker connected, great current flows to the power transistor, then voltage is generated between A - B, and Q701 turns "on" when the voltage exceeds V1. (Note 1)
- ② When Q701 turns "on", current flows to R707 and R705, causing Q705 to turn "on".
- ③ As (+B) voltage comes to the collector of Q705, each of Q703, Q707 and Q709 turns "on", and voltage is applied to D715, D705 and D707, then the collector voltage of pre-drive Q317 and Q319 is controlled to a degree 16V lower than (+B) voltage. Controlling the collector voltage of Q317 and Q319 is intended to control the great current of power transistor.
- ④ As Q703 is "on", even if the current of power transistor is then reduced, ③ is not reset allowing output control to continue when the voltage between A - B is higher than V2. (Note 2)
- ⑤ When the voltage between A - B is lower than V2 (Note 2) as the current of power transistor is reduced, then Q701 turns "off" and ③ is reset.

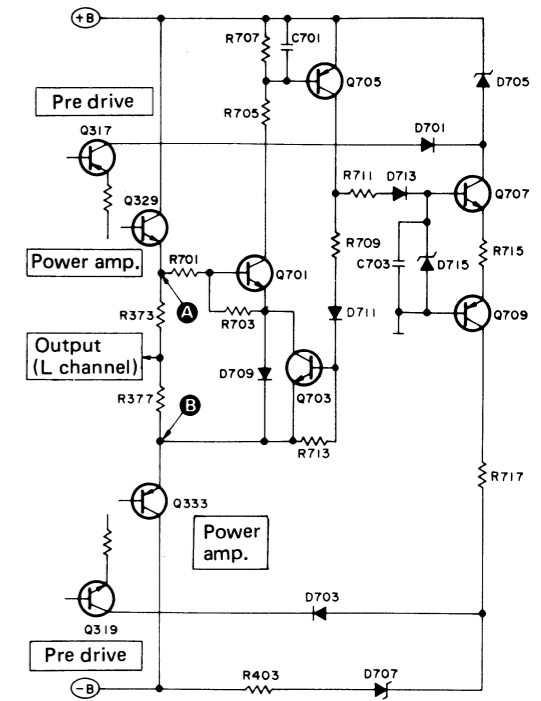

[Note 1] $V1 = \frac{R1+R2}{R2} \cdot Vbe + Vf$

[Note 2] $V2 = \frac{R1+R2}{R2} \cdot Vbe + Vsat$

R1 : Resistance value of R701
 R2 : Resistance value of R703
 Vbe : Base - emitter voltage to turn Q701 "on"
 Vf : Forward voltage of Q709
 Vsat : Collector - emitter saturation voltage of Q701

[Fig. 9]

BLOCK DIAGRAM

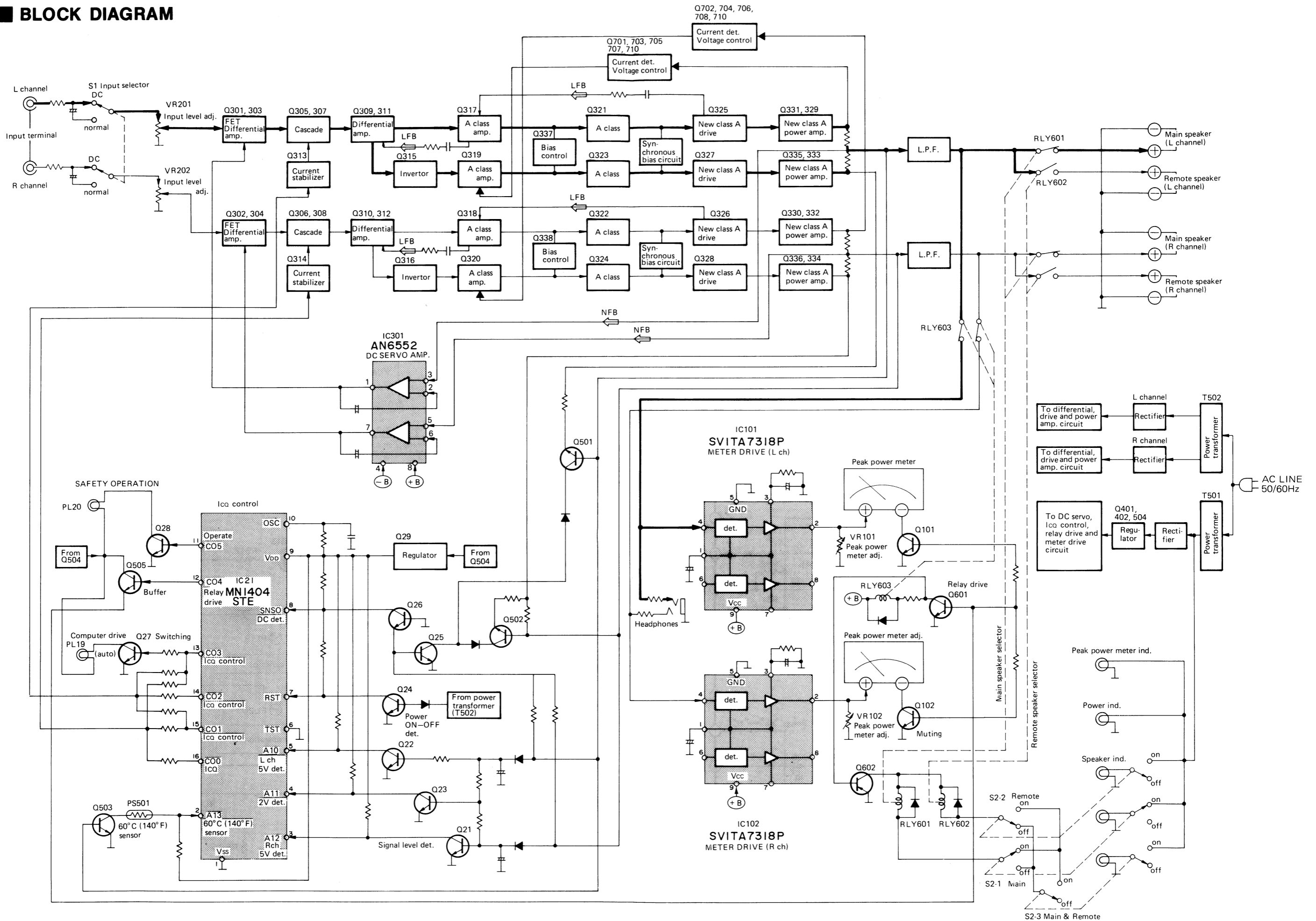

B DIFFERENTIAL AMP./CASCADE/DC SERVO/ PRE DRIVE AMP. CIRCUIT

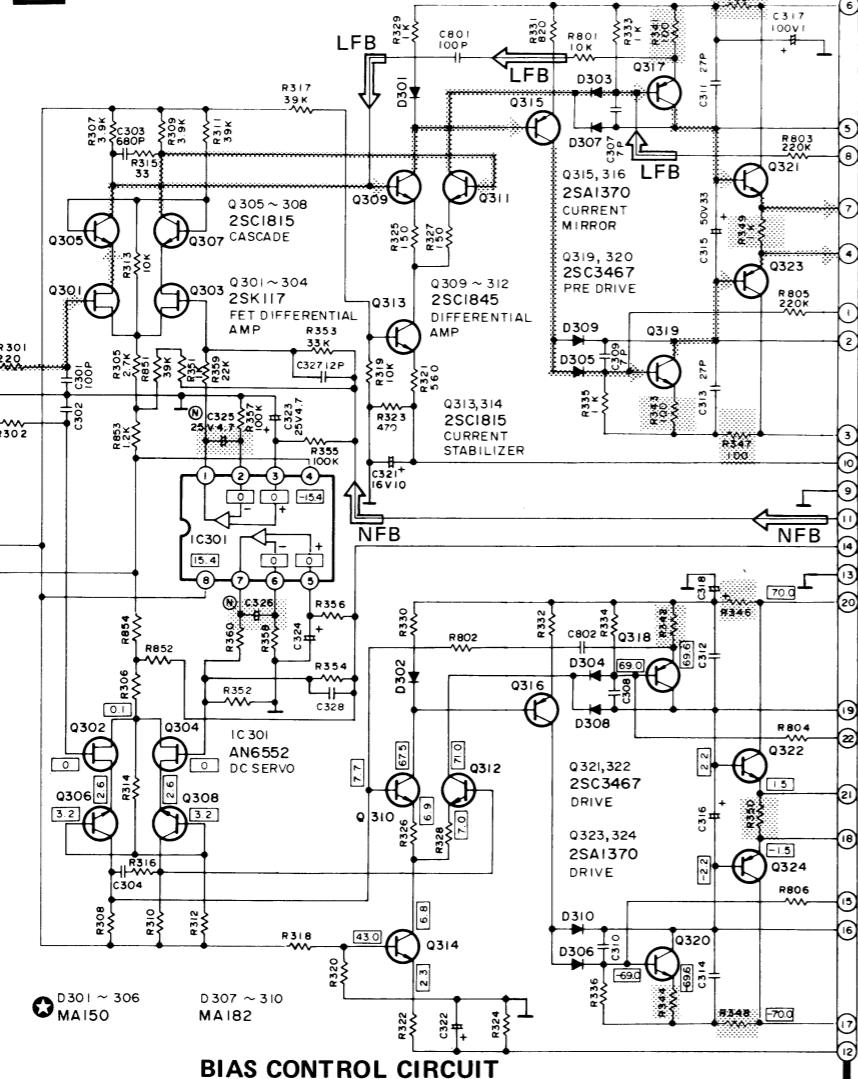

C SIGNAL DET./DC DET./ POWER ON-OFF DET./ Icq CONTROL CIRCUIT

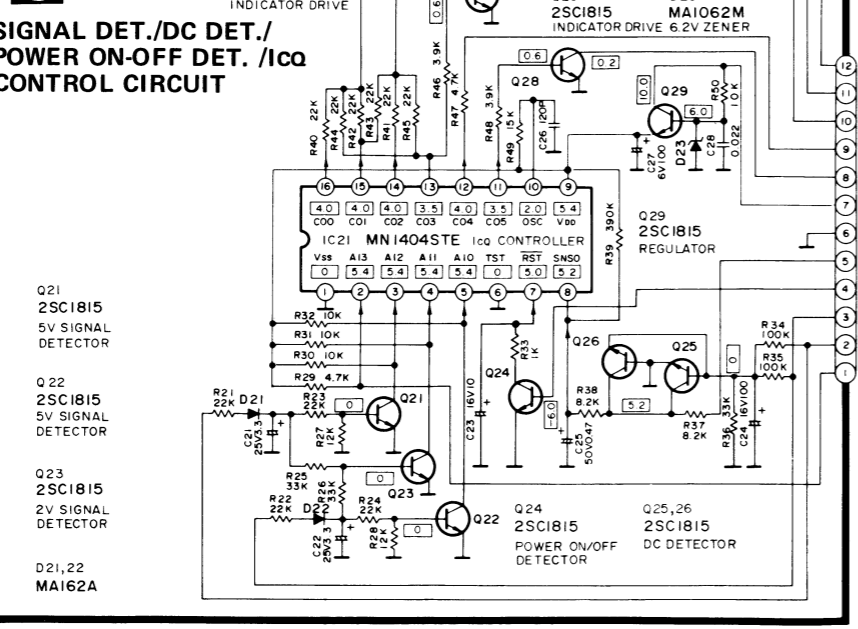

D SYNCHRO BIAS/Icq CONTROL/DRIVE/POWER AMP./ OVERLOAD DET./POWER SUPPLY CIRCUIT

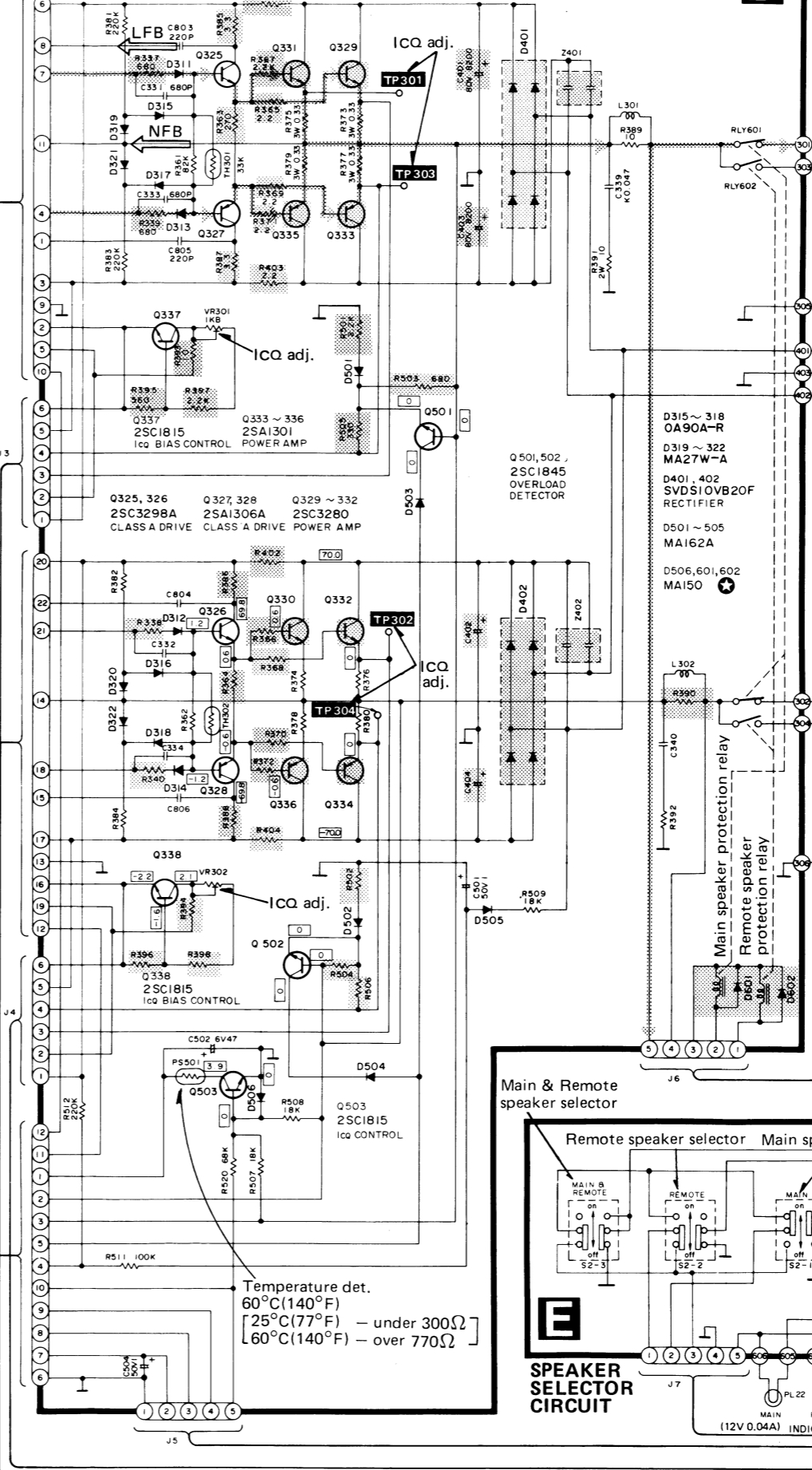

F SPEAKER TERMINAL CIRCUIT

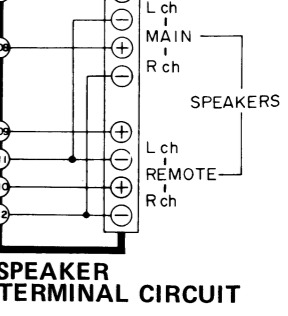

G HEADPHONES JACK CIRCUIT PEAK POWER METER

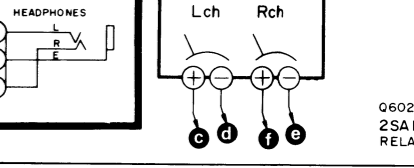

E SPEAKER SELECTOR CIRCUIT

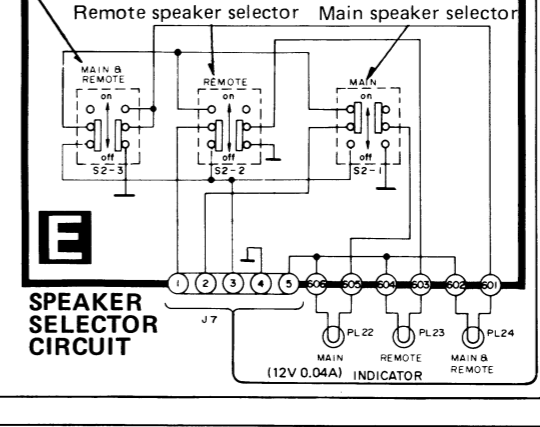

H CURRENT DET./METER DRIVE/REGULATOR/ RELAY DRIVE/POWER SUPPLY CIRCUIT



SCHEMATIC DIAGRAM

(This schematic diagram may be modified at any time with the development of new technology.)

- The part No. of transistors, IC and diodes mentioned in the schematic diagram stand for production part No. Regarding the Part No. with \odot mark, the production part No. are different from the replacement part No. Therefore, when placing an order for replacement parts, please use the part No. in the replacement parts list.

Notes:

- S1** : Input level selector switch in "DC" position.
DC \leftrightarrow normal
- S2-1 ~ S2-3** : Speaker selector switch in "main" position.
S2-1: main, S2-2: remote, S2-3: main and remote
- S501** : Power switch in "on" position.
- \square Indicated voltage values are the standard values for the DC electronic circuit tester (high impedance) with the chassis taken as standard. Therefore, there may exist some errors in the voltage values, depending on the internal impedance of the DC circuit tester.
- \cdots Phono signal lines of left channel.
- --- Positive (+B) voltage lines or negative (-B) voltage lines.

IMPORTANT SAFETY NOTICE

The shaded area on this schematic diagram incorporates special features important for protection from fire and electrical shock hazards. When servicing it is essential that only manufacturer's specified parts be used for the critical components in the shaded areas of the schematic.

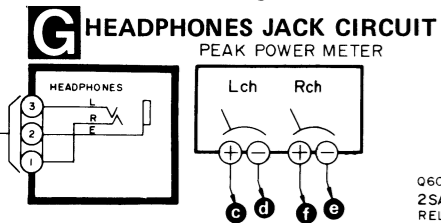
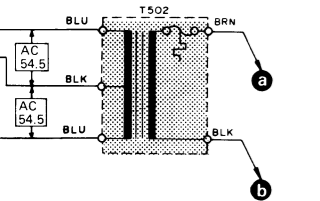
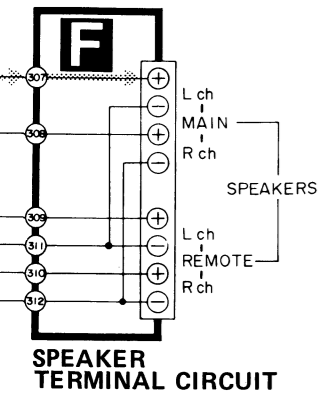

Q602
2SA1015
RELAY DRIVE

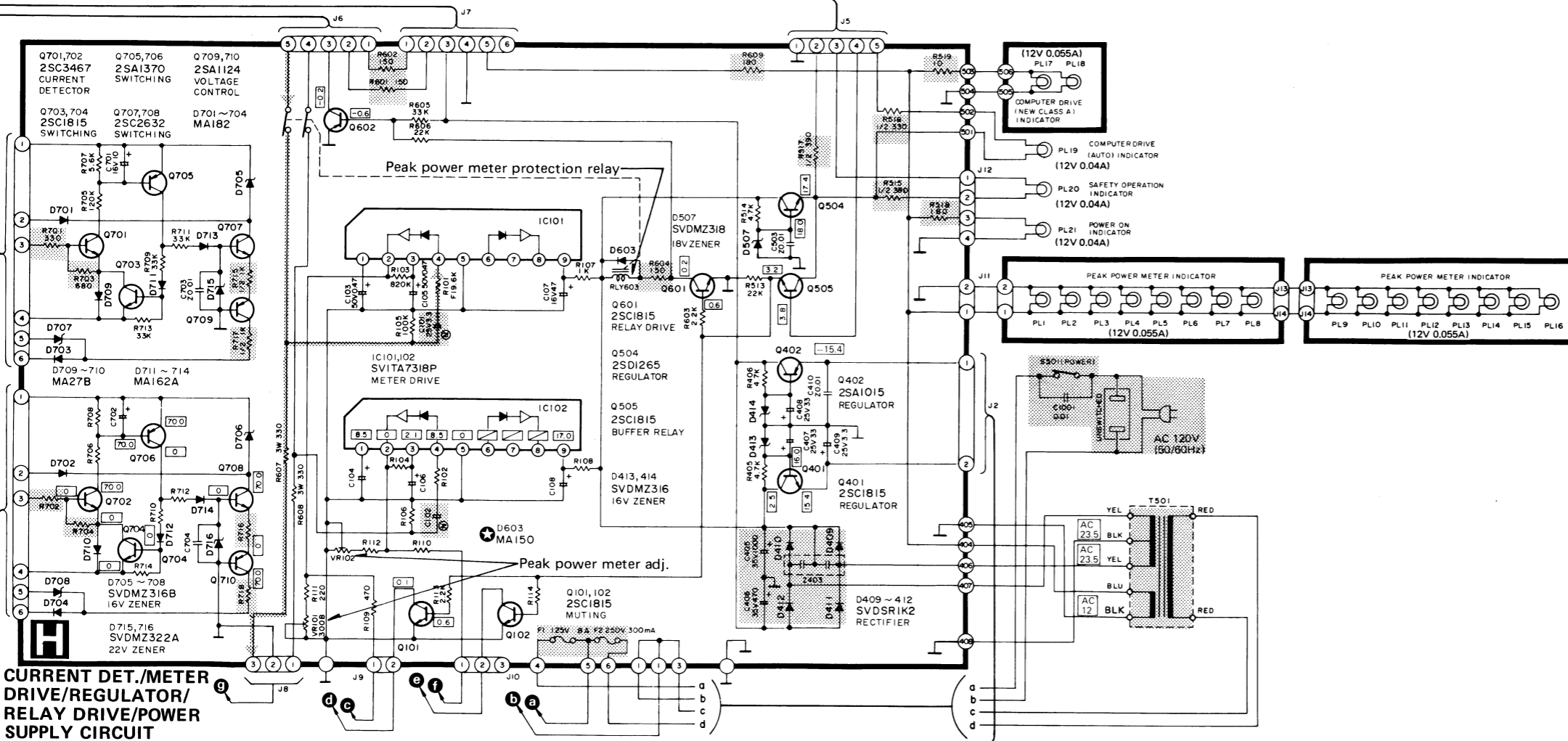

Terminal guide of transistors, diodes and IC's

MN1404STE 16 pin AN6552 8 pin		SVTA7318P 	2SC1815, 2SC1845 2SA1015, 2SC2632 2SA1124, 2SA1370 2SC3467
2SK117 	2SD1265 	2SA1306, 2SC3298 	2SA1301, 2SC3280
MA162A 	MA1062M 	MA150, MA182 0A90AR 	MA27W-A
SVDS10VB20F 	SVDSR1K2 	SVDMZ316, SVDMZ318, SVDMZ322 	

REPLACEMENT PARTS LIST . . . Cabinet & Chassis Parts

- Notes:**
- Part numbers are indicated on most mechanical parts. Please use this part number for parts orders.
 - Important safety notice:
Components identified by Δ mark have special characteristics important for safety. When replacing any of these components use only manufacturer's specified parts.
 - The "S" mark is service standard parts and many differ from production parts.
 - The parenthesized numbers in the column of description stand for the quantity per set.
 - Bracketed indications in Ref. No. columns specify the areas. Parts without these indications can be used for all areas.

Areas

- * [M] is available in the U.S.A.
- * [MC] is available in Canada.

EXPLODED VIEWS

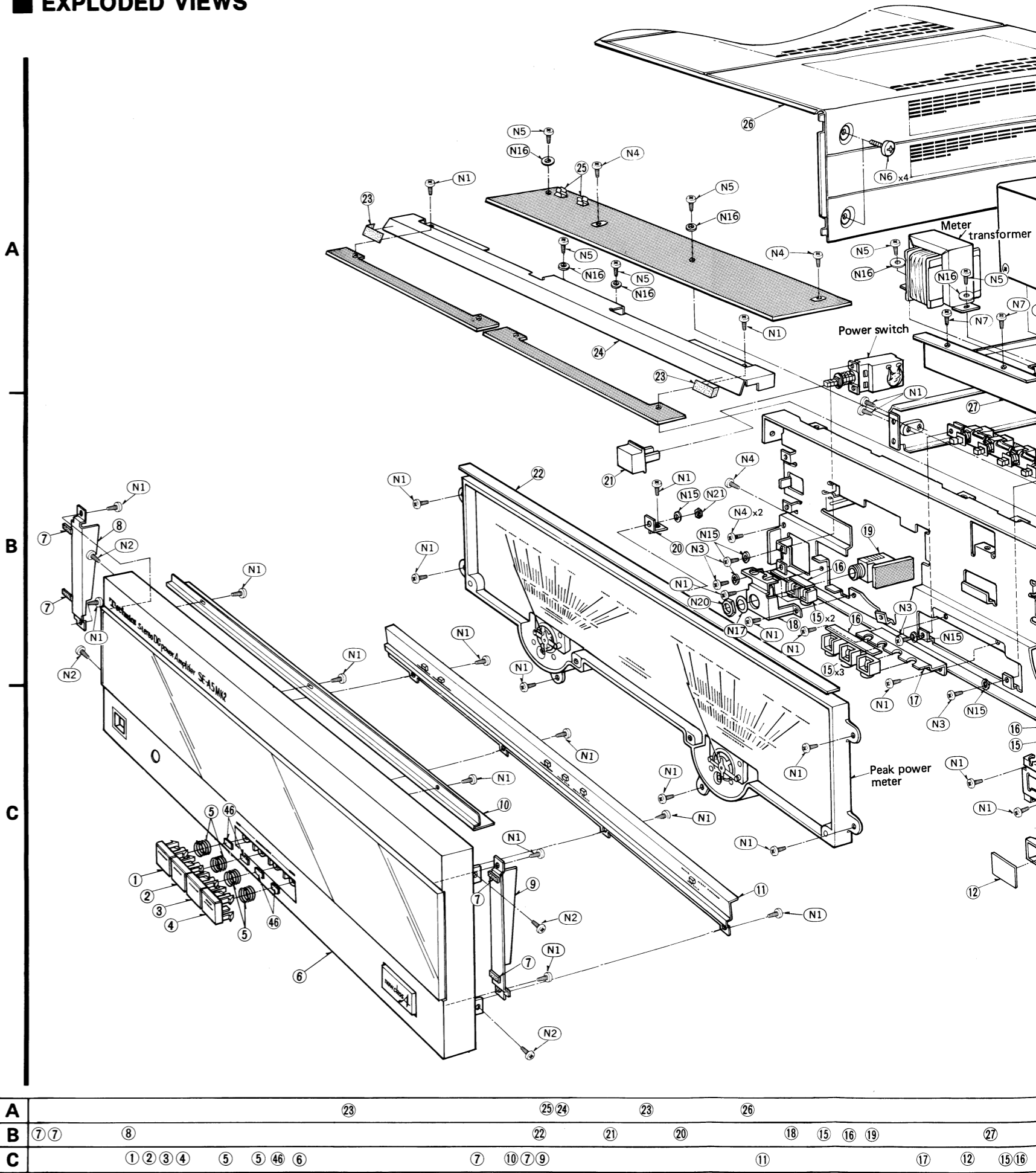

Ref. No.	Part No.	Part Name & Description
INTEGRATED CIRCUITS		
IC21	MN1404STE	ICQ Controller
IC101, 102	SVTA7318P	Meter Drive
IC301	AN6552F	DC Servo
TRANSISTORS		
Q21~29, 101, 102, 313, 314, 337, 338, 401, 503, 505, 601, 703, 704	2SC1815-Y	Signal Detector, DC Detector, Indicator Drive, Regulator, Muting, Current Stabilizer, Bias Control, ICQ Control, Switching FET Differential Amp.
Q301~304	2SK117-GR	Cascade
Q305~308	2SC1815-G	Differential Amp.
Q309~312	2SC1845-E	Current Mirror
Q315~318, 323, 324	2SA1370-D	Pre Drive, Drive Pre Drive, Drive Class A Drive
Q319~322	2SC3467-D	Class A Drive
Q325, 326	2SC3298A-Y	Class A Drive
Q327, 328	2SA1306A-Y	Power Amp.
Q329~332	2SC3280-R	Power Amp.
Q333~336	2SA1301-R	Regulator, Relay Drive
Q402, 602	2SA1015-Y	Over load Detector
Q501, 502	2SC1845-E	Regulator
Q504	2SD1265-O	Current Detector
Q701, 702	2SC3467-D	Switching
Q705, 706	2SA1370-D	Switching
Q707, 708	2SC2632-R	Switching
Q709, 710	2SA1124-R	Voltage Control
DIODES		
D21, 22, 301~306, 501~506, 601~603, 711~714	MA162A	Switching
D23	MA1062M	Zener, 6.2V
D307~310, 701~704	MA182	Switching
D311~318	OA90A-R	Rectifier
D319~322	MA27W-A	Rectifier
D401, 402	SVDS10VB20F	Rectifier
D409~412	SVDSR1K2	Rectifier
D413, 414	SVDMZ316A	Zener, 16V
D507	SVDMZ318	Zener, 18V
D705~708	SVDMZ316B	Zener, 16V
D709, 710	MA27B	Zener, 22V
D715, 716	SVDMZ322A	Zener, 22V
COILS		
L301, 302	SLQY15G-30	Choke Coil
TRANSFORMERS		
T501	SLT5S68	Power Source
T502	SLT5L178	Meter
VARIABLE RESISTORS		
VR101, 102	EVNK6AA00B32	Power Meter Adj., 300Ω (B)
VR201, 202	EVH6UA524B54	Input Level, 50kΩ (B)
VR301, 302	EVNK6AA00B13	ICQ Adj., 1kΩ (B)
THERMISTERS		
TH301, 302	ERTD2ZHL333S	33kΩ
COMPONENT COMBINATIONS		
Z401~403	SXRF203ZSM	0.01μF (x2)

Ref. No.	Part No.	Part Name & Description
THERMAL DETECTOR		
PS501	SRPBG47101	
RELAY		
RLY601, 602	SSY124	Speaker
RLY603	SSY9	Meter
LAMP		
PL1~18	XAMR74S17	Meter (12V, 0.055A)
PL19~21	XAMR48S230	Computer Drive, Safety Operation, Power (12V, 0.04A)
PL22~24	XAMR48T250	Speaker Ind. (12V, 0.04A)
METER		
	SSM161-1	Peak Power Meter
FUSES		
F1	XBA1F80NU14	125V, 8A
F2	XBA2F03NU100	250V, 300mA
SWITCHES		
S1	SSS49	Input Selector
S2	SSH475	Speaker
S3	ESB9939T	Power Source
CABINET PARTS and CHASSIS PARTS		
1	SBC645-1A	Button, (off) (1)
2	SBC645-1B	Button, (main) (1)
3	SBC645-1C	Button, (remote) (1)
4	SBC645-1D	Button, (main and remote) (1)
5	SUS191-2	Spring, Button (4)
6	SGWEA5MK2-KM	Front Panel, Ass'y (1)
7	SHG6349	Rubber (4)
8	SGE693-1	Bracket, Left (1)
9	SGE693	Bracket, Right (1)
10	SGE697	Reflector Plate (1)
11	SGEEA5MK2-KN	Ornament (1)
12	SDE259-1	Filter, Lamp (1)
13	SMP305	Case, Lamp (1)
14	SUW2155	Bracket, Lamp Case (1)
15	SHG1575	Rubber, Lamp (6)
16	SHP9379	Sheet, Lamp (2)
17	SMP293	Bracket, Lamp (1)
18	SMK61	Bracket, Headphone (1)
19	SJJ71B	Jack, Headphone (1)
20	SUW1955	Bracket, Meter (1)
21	SBC627	Button, Power Source (1)
22	SDU35-1	Filter, Meter (1)
23	SHS6129	Sheet (2)
24	SMP371	Reflector Plate (1)
25	SJT345	Holder, Fuse (4)
26(M)	SKCEA5MK2-KM	Cabinet (1)
26(MC)	SKCEA5MK2-KC	Cabinet (1)
27	SML101-1	Bracket, Power Transformer (1)
28	SUW2153-3	Bracket (1)
29	SMN1895-1	Bracket (1)
30	SUW1595	Bracket (1)
31	SUW1701	Bracket (1)
32	SUW1593	Bracket (1)

Ref. No.	Part No.	Part Name & Description
CABINET PARTS and CHASSIS PARTS		
33	SUW2153-2	Bracket (1)
34	SKU8210-3	Bottom Board (1)
35	SKL247-2	Foot, Bottom Side (4)
36	SJF3225-2A	Terminal Board (1)
37	SMN1729-1	Bracket, Input Level Volume (1)
38	SJT231	Terminal (1)
39	SJF4817	Terminal Board, Speaker (1)
40	SHR129	Bushing (1)
41	SJA129-1	AC Cord (1)
42(M)	SJS9221	Socket, AC Outlet (1)
42(MC)	SJS9223	Socket, AC Outlet (1)
43(M)	SGP2391C	Rear Panel (1)
43(MC)	SGPEA5MK2-KC	Rear Panel (1)
44	SBN613	Knob, Input Level Volume (2)
45	SKL241	Foot, Rear Side (4)
46	SHG1509	Rubber, Button (4)
47	SHS2445	Sheet (2)
48	SHS2437	Sheet (1)
SCREWS		
N1	XTB3+8BFZ	Tapping, $\phi 3 \times 8$ (30)
N2	XTS3+8BFZ	Tapping, $\phi 3 \times 8$ (4)
N3	XSN3+6S	$\phi 3 \times 6$ (4)
N4	XTBS3+8BFZ1	Tapping with Detent, $\phi 3 \times 8$ (4)
N5	XTN3+8B	Tapping, $\phi 3 \times 8$ (2)
N6	XSS5+12FIS	$\phi 5 \times 12$ (8)
N7	XTB4+10BFN	Tapping, $\phi 4 \times 10$ (2)
N8	XTB4+8F	Tapping, $\phi 4 \times 8$ (8)
N9	XTW3+12J	Tapping, $\phi 3 \times 12$ (8)
N10	XTB3+10FFZ	Tapping, $\phi 3 \times 10$ (4)
N11	XTB4+12FFZ	Tapping, $\phi 4 \times 12$ (4)
WASHERS		
N15	XWA3B	Spring, $\phi 3$ (5)
N16	XWG3	Plain, $\phi 3$ (2)
N17	SNE59-1	(1)
N18	XWC3B	External Toothed Lock, $\phi 3$ (1)
NUTS		
N20	XNS12	$\phi 12$ (1)
N21	XNG3ES	$\phi 3$ (1)
N22	SNE4021	(2)
ACCESSORIES		
A1	SJP2239	Cord, Connection (1)
A2(M)	SQF12032	Instruction Book (1)
A2(MC)	SQF12033	Instruction Book (1)
PACKING PARTS		
P1	SPP653	Polyethylene Bag (1)
P2	SPH211	Sheet (1)
P3	SPS4303-1	Pad, Bottom (1)
P4	SPS4305-2	Pad, Upper (1)
P5(M)	SPG4787	Carton Box (1)
P5(MC)	SPG4788	Carton Box (1)

SE-A5MK2 SE-A5MK2

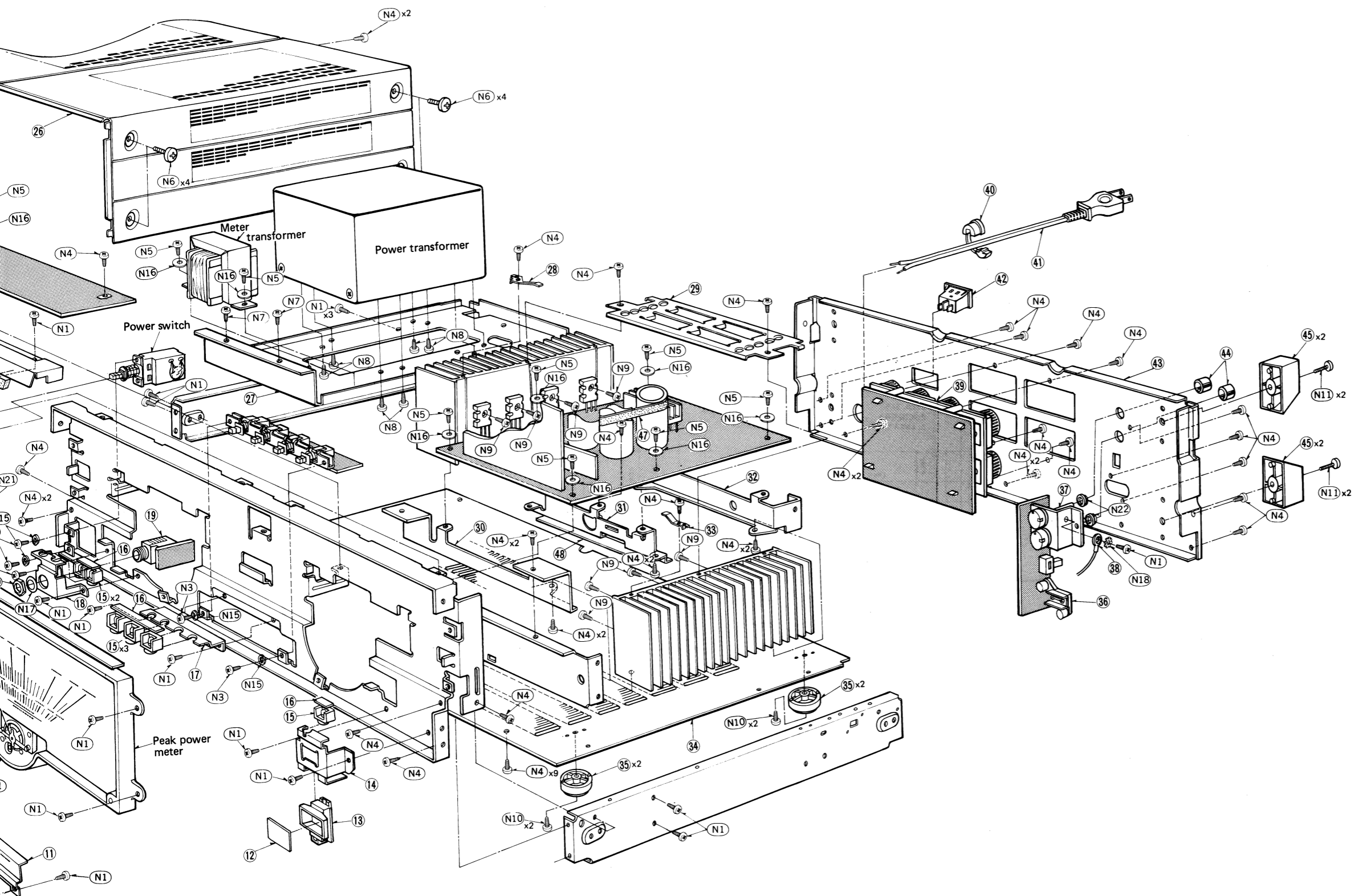

26	18	15	16	19	27	30	28	48	31	47	33	32	39	40	42	41	43	44	45
11	17	12	15	16	13	14	35	34	35	36	37	38	36	37	36	38	36	37	38