

Service Manual

Amplifier

SE-CA01

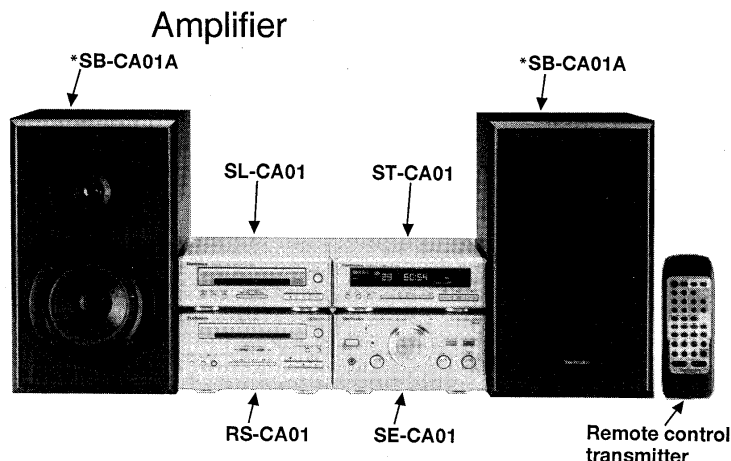

Colour

(N)...Gold Type

Areas

Suffix for Model No.	Area	Colour
(E)	Europe.	(N)
(EB)	Great Britain.	
(EG)	Germany and Italy.	

System: SC-CA01

Because of unique interconnecting cables, when a component requires service, send or bring in the entire system.

■ SPECIFICATIONS

■ Amplifier section

Power output	
DIN 1 kHz, THD 1%, both channel driven	2×45 W (6Ω)
RMS 1 kHz, THD 10%, both channel driven	2×60 W (6Ω)
Total harmonic distortion	
Rated power at 1 kHz	1% (6Ω)
Half power at 1 kHz	0.09% (6Ω)
Load impedance	6Ω

■ General

Power consumption	100 W
Power supply	
[For (E, EG) areas]	230 V, AC 50 Hz
[For (EB) area]	230 – 240 V, AC 50 Hz
Dimensions (W×H×D)	186×103×255 mm
Weight	3.9 kg

Notes:

1. Specifications are subject to change without notice.
2. Weight and dimensions are approximate.
3. Total harmonic distortion is measured by the digital spectrum analyzer.

System	Tuner	CD Player	Amplifier	Cassette deck	Speakers
SC-CA01	ST-CA01	SL-CA01	SE-CA01	RS-CA01	*SB-CA01A

*Made in PAES

△ WARNING

This service information is designed for experienced repair technicians only and is not designed for use by the general public. It does not contain warnings or cautions to advise non-technical individuals of potential dangers in attempting to service a product. Products powered by electricity should be serviced or repaired only by experienced professional technicians. Any attempt to service or repair the product or products dealt with in this service information by anyone else could result in serious injury or death.

Technics®

© 1996 Matsushita Electric Industrial Co., Ltd.
All rights reserved. Unauthorized copying and distribution is a violation of law.

CONTENTS

	Page		Page
ACCESSORIES	2	POWER SOURCE ON/OFF OF THIS UNIT	10
BEFORE REPAIR AND ADJUSTMENT	2	REPLACEMENT OF THE FOOT	10
PROTECTION CIRCUITRY	3	WIRING CONNECTION DIAGRAM	11
CAUTION FOR AC MAIN LEAD	3	BLOCK DIAGRAM	12, 13
LOCATION OF CONTROLS	4	PRINTED CIRCUIT BOARD DIAGRAM	14~16
INSTALLATION	4	SCHEMATIC DIAGRAM	17~22
SYSTEM EQUIPMENT CONNECTIONS	5, 6	RESISTORS AND CAPACITORS	23, 24
OPTIONAL ANTENNA CONNECTIONS AND EXTERNAL UNIT CONNECTIONS	7	CABINET PARTS LOCATION	25
OPERATION CHECK AND MAIN COMPONENT REPLACEMENT PROCEDURES	8, 9	REPLACEMENT PARTS LIST	24, 26~28
		PACKAGING	28

ACCESSORIES

- AC power supply cord 1 pc.
For (E, EG) areas: (RJA0019-2K)
For (EB) area: (VJA0733)
- Flat cable 1 pc.
Long (REX0812)/Middle (REX0813)/
Short (REX0608)
- Screw 1 pc.
(XTN3+12AFZ)
- Remote control transmitter 1 pc.
(RAK-CH193WH)
- AM loop antenna 1 pc.
(RSA0012)
- Antenna holder 1 pc.
(RMN0244)
- Batteries 2 pcs.
(UM-4, "AAA", R03)
Note: These are available on sales route.
- FM indoor antenna 1 pc.
(RSA0007)
- Speaker cords 2 pcs.
(RFA0737-R)
- Attachment plug 1 pc.
For (EB) area only: (SJP9009)

BEFORE REPAIR AND ADJUSTMENT

- (1) Turn off the power supply using a 10 Ω, 10 W resistor, connect both ends of power supply capacitors (C715~718) in order to discharge the voltage.
- (2) Before turning the power supply on, after completion of repair, slowly apply the primary voltage by using a power supply voltage controller to make sure that the consumed current at 50/60 Hz in NO SIGNAL mode should be shown below with respect to supply voltage 230 V/240 V.

Area	(E) (EG)		(EB)	
	AC 230 V		AC 240 V	
Consumed current 50/60 Hz	50 Hz	60~180 mA	50 Hz	55~175 mA
	60 Hz	48~144 mA	60 Hz	44~140 mA

■ PROTECTION CIRCUITRY

The protection circuitry may have operated if either of the following conditions is noticed:

- * No sound is heard when the power is switched ON.
- * Sound stops during a performance.

The function of this circuitry is prevent circuitry damage if, for example, the positive and negative speaker connection wires are "shorted", or if speaker systems with an impedance less than the indicated rated impedance of this unit are used.

If this occurs, follow the procedure outlined below:

1. Switch OFF the power.
2. Determine the cause of the problem and correct it.
3. Switch ON the power once again.

Note:

When the protection circuitry functions, the unit will not operate unless the power is first switched OFF and then ON again.

■ CAUTION FOR AC MAIN LEAD

[For (EB) area only.]

For your safety, please read the following text carefully.

This appliance is supplied with a moulded three pin mains plug for your safety and convenience.

A 5-ampere fuse is fitted in this plug.

Should the fuse need to be replaced please ensure that the replacement fuse has a rating of 5-ampere and that it is approved by ASTA or BSI to BS1362.

Check for the ASTA mark or the BSI mark on the body of the fuse.

If the plug contains a removable fuse cover you must ensure that it is refitted when the fuse is replaced.

If you lose the fuse cover the plug must not be used until a replacement cover is obtained.

A replacement fuse cover can be purchased from your local dealer.

CAUTION!

IF THE FITTED MOULDED PLUG IS UNSUITABLE FOR THE SOCKET OUTLET IN YOUR HOME THEN THE FUSE SHOULD BE REMOVED AND THE PLUG CUT OFF AND DISPOSED OF SAFELY.

THERE IS A DANGER OF SEVERE ELECTRICAL SHOCK IF THE CUT OFF PLUG IS INSERTED INTO ANY 13-AMPERE SOCKET.

If a new plug is to be fitted please observe the wiring code as shown below.

If in any doubt please consult a qualified electrician.

IMPORTANT

The wire in this mains lead are coloured in accordance with the following code:

- Blue: Neutral
- Brown: Live

As the colours of the wires in the mains lead of this appliance may not correspond with the coloured markings identifying the terminals in your plug, proceed as follows:

The wire which is coloured BLUE must be connected to the terminal in the plug which is marked with the letter N or coloured BLACK.

This apparatus was produced to BS 800.

The wire which is coloured BROWN must be connected to the terminal in the plug which is marked with the letter L or coloured RED.

Under no circumstances should either of these wires be connected to the earth terminal of the three pin plug, marked with the letter E or the Earth Symbol

Before use

Remove the connector cover as follows.

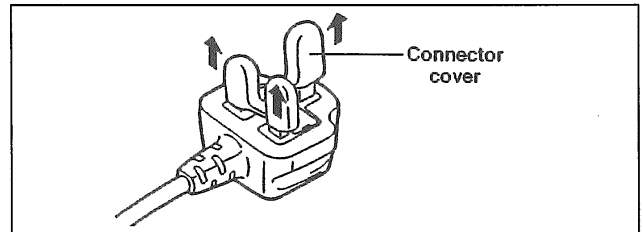

How to replace the fuse

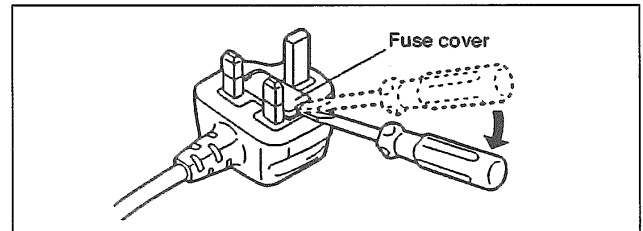

1. Remove the fuse cover with a screwdriver.

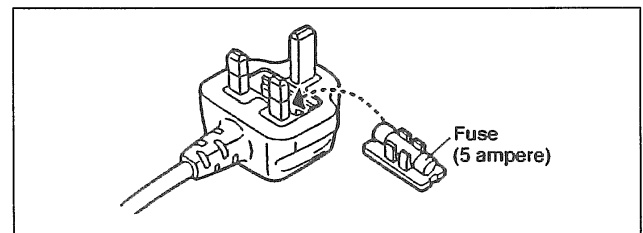

2. Replace the fuse and attach the fuse cover.



LOCATION OF CONTROLS

- ① Power "STANDBY  /ON" switch
(POWER, STANDBY  /ON)
Press to switch the unit from on to standby mode or vice versa. In standby mode, the unit is still consuming a small amount of power.
- ② Standby indicator (STANDBY)
When the unit is connected to the AC mains supply, this indicator lights up in standby mode and goes out when the unit is turned on.
- ③ Volume control (VOLUME)
- ④ Source direct button (SOURCE DIRECT)
- ⑤ Vocal presence button (VOCAL PRESENCE)
- ⑥ Headphones jack (PHONES)
- ⑦ Balance control (BALANCE)
- ⑧ Bass control (BASS)
- ⑨ Treble control (TREBLE)

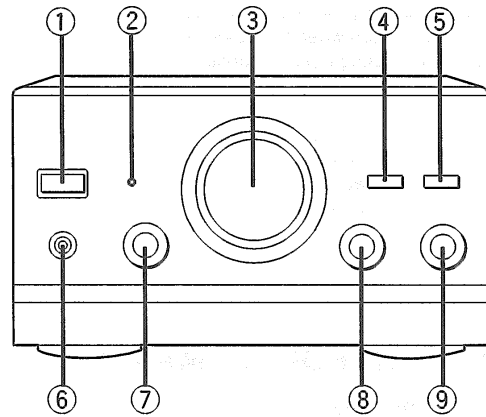

INSTALLATION

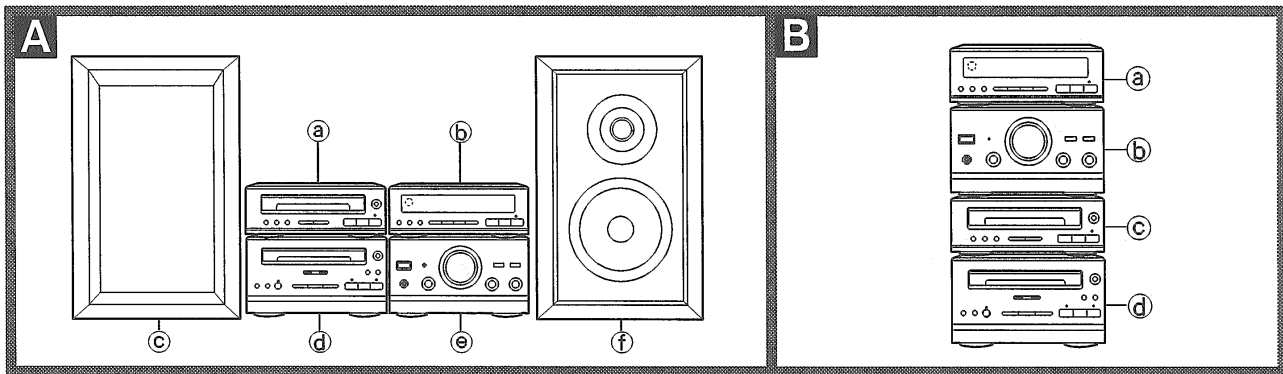

Stacking the components

Horizontal stacking

- Ⓐ CD player (SL-CA01)
- Ⓑ Tuner (ST-CA01)
- Ⓒ Left speaker (SB-CA01A)
- Ⓓ Cassette deck (RS-CA01)
- Ⓔ Amplifier (SE-CA01)
- Ⓕ Right speaker (SB-CA01A)

Vertical stacking

- Ⓐ Tuner (ST-CA01)
- Ⓑ Amplifier (SE-CA01)
- Ⓒ CD player (SL-CA01)
- Ⓓ Cassette deck (RS-CA01)

Caution

Use the speakers only with the recommended system. Failure to do so may lead to damage to the amplifier and/or the speakers, and may result in the risk of fire. Consult a qualified service person if damage has occurred or if you experience a sudden change in performance.

Note

Left and right speakers are exactly the same.

SYSTEM EQUIPMENT CONNECTIONS

● Flat cable (included) connections

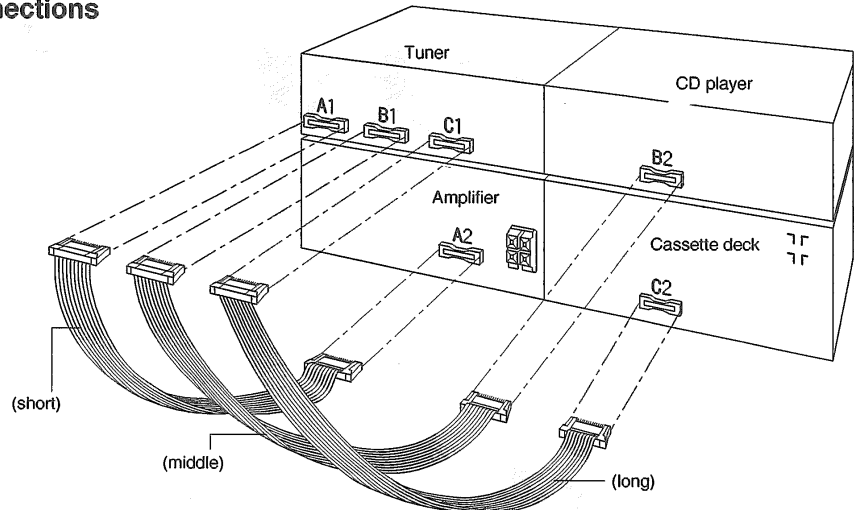

Before making connections:
Make sure the white line on the cable is on the right side.

To unplug cables:
Hold the connector from both ends.

Note Do not try connecting or disconnecting the flat cables while the power is switched to ON.

After connection:
Keep cables as flat against the back of the unit as possible. You may fold them or pass them underneath the short cable as shown below.

● Antenna connections

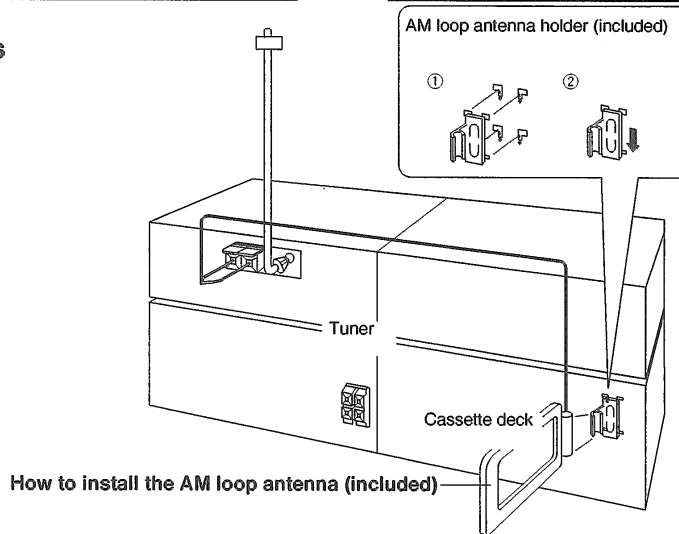

① Strip off the outer covering. → Twist.

② Insert the wire.

③ Close the lever.

④ Attach the AM loop antenna to the antenna holder.

Note

- To minimize noise pickup, bundle the loop antenna cord using a tape or so to keep the flat cables away from the AM loop antenna cord.
- You may attach the antenna holder to a rack or other structure.

● **When mounting the antenna to a column or rack**

AM loop antenna holder (included)

Screw (included)

● Connection of speakers

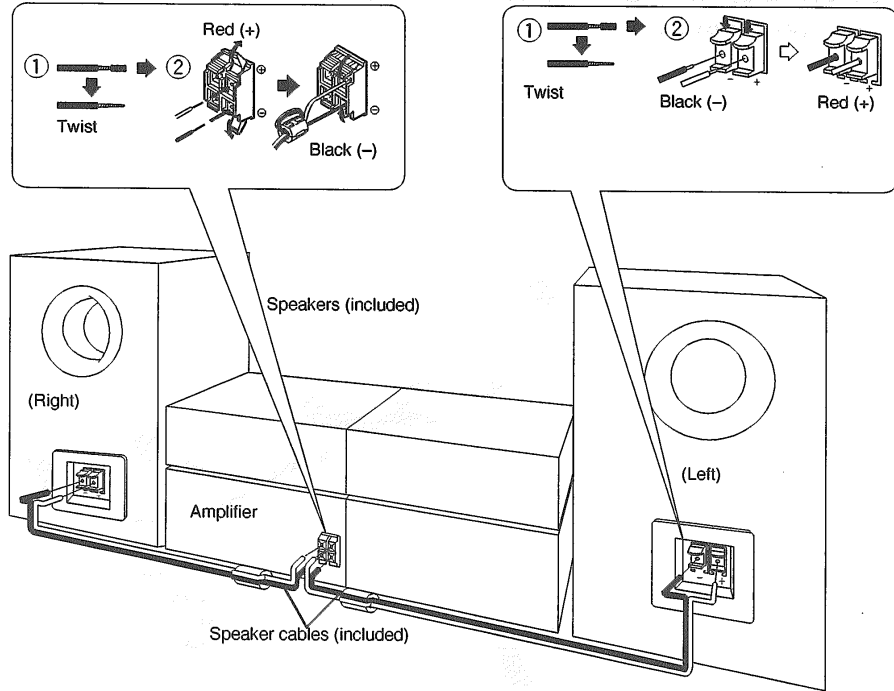

Note

- Connect the end of the speaker cable with the cylindrical sleeve to the amp side.
- To prevent damage to circuitry, never short-circuit positive (+) and negative (-) speaker wires.
- Be sure to connect only positive (red) wires to positive (+) terminals and negative (black) wires to negative (-) terminals.
- This set can only be used with the original speaker cables, which are delivered together with the standard accessories.

● Connection of AC power supply cord

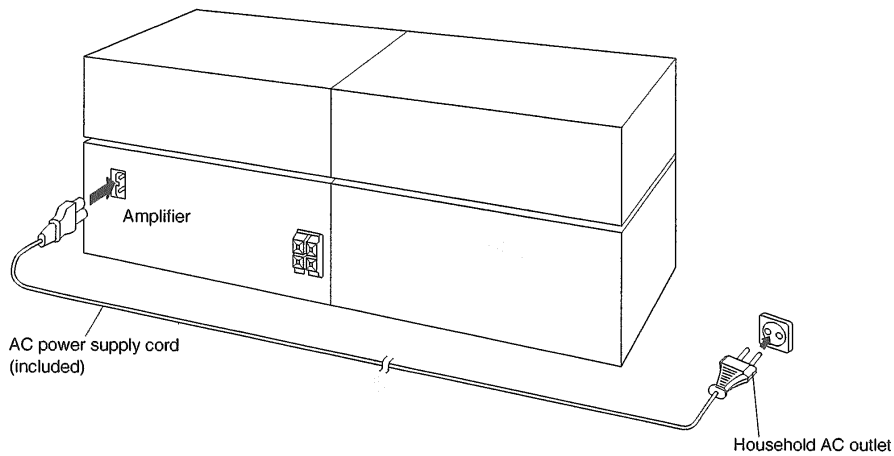

- Plug the cord into an outlet only after all other connections have been made.

Insertion of Connector:
 Even when the connector is perfectly inserted, depending on the type of inlet used, the front part of the connector may jut out as shown in the drawing.
 However there is no problem using the unit.

OPTIONAL ANTENNA CONNECTIONS AND EXTERNAL UNIT CONNECTIONS

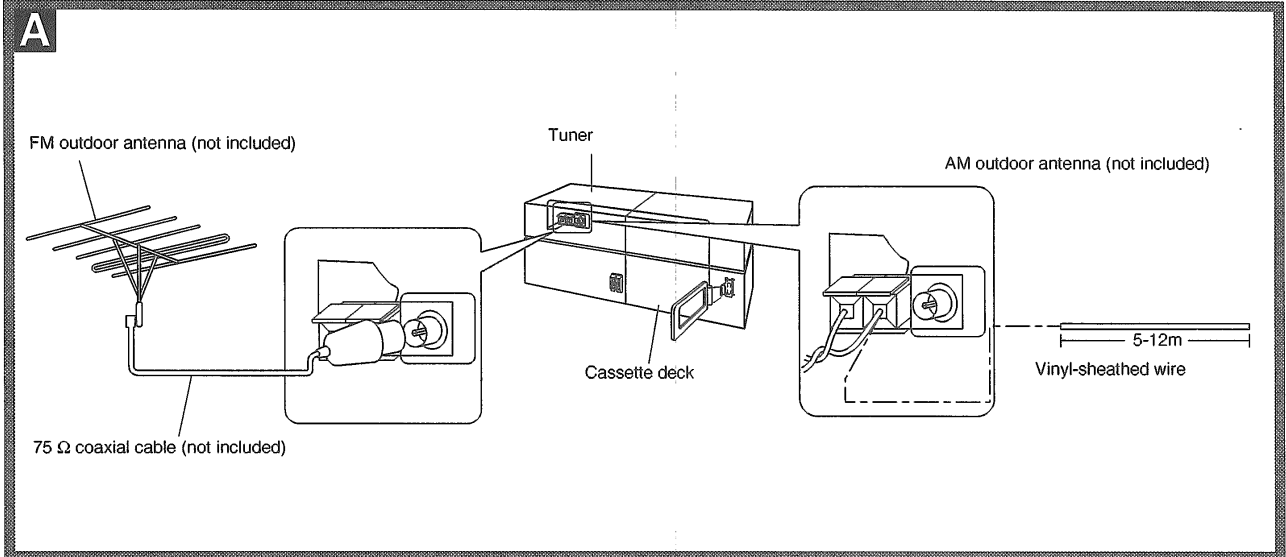

FM outdoor antenna (not included) **A**

The outdoor antenna should be used when using this unit in mountainous areas or in spaces enclosed by reinforced concrete where the FM indoor antenna (included) does not provide satisfactory reception.

Note

An outdoor antenna should be installed by a qualified technician only.

AM outdoor antenna (not included) **A**

The outdoor antenna should be used when using this unit in mountainous areas or in spaces enclosed by reinforced concrete where the AM loop antenna (included) does not provide satisfactory reception.

Use 5-12 m of vinyl-sheathed wire horizontally at the window, or a convenient location.

When the unit is not in use, disconnect the outdoor antenna to prevent possible damage from lightning. Never use an outdoor antenna during an electrical storm.

Note

Be sure to connect the AM loop antenna even when an outdoor antenna is used.

Connecting a cassette deck **B**

- Make sure that the power supply for all components has been turned off before making any connections.
- For details, refer to the operating instructions of the cassette deck which is to be connected.
- All peripheral components and cables sold separately.

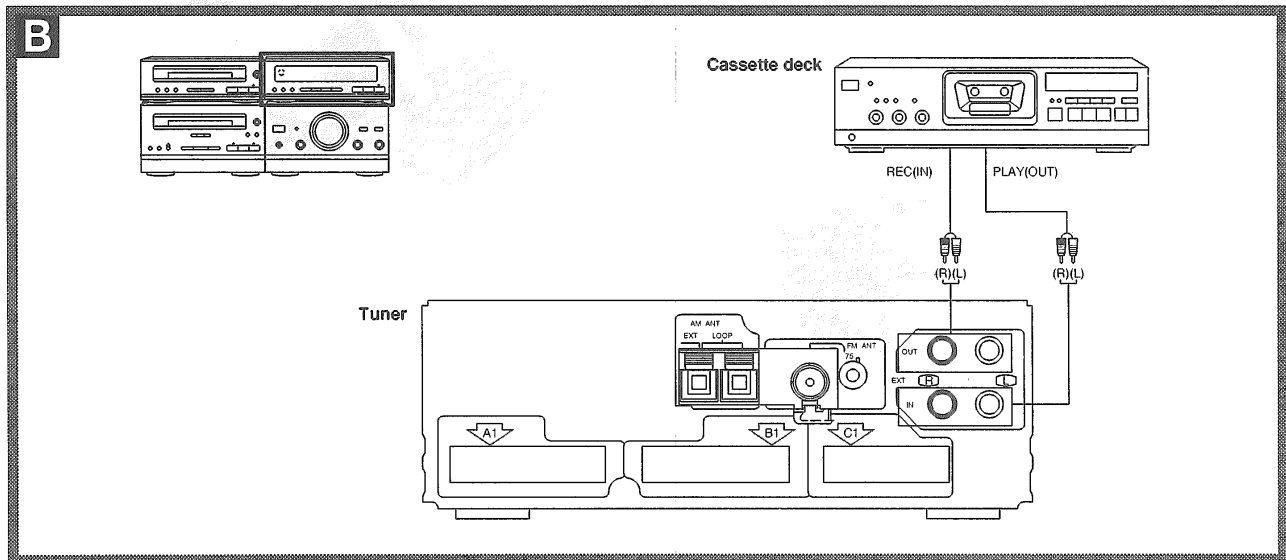
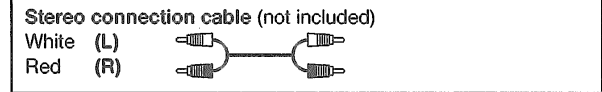

■ Operation Check and Main Component Replacement Procedures

NOTE

1. This section describes procedures for checking the operation of the major printed circuit boards and replacing the main components.
2. For reassembly after operation checks or replacement, reverse the respective procedures. Special reassembly procedures are described only when required.
3. Select items from the following index when checks or replacement are required.
4. Illustrated screws are equivalent to actual size.
5. Refer the parts No. on the page of "Main Component Replacement Procedures", if necessary.

● Contents

•Checking Procedures for each P.C.B.	Page.
1. Checking for the operation P.C.B..	8.
2. Checking for the PDM P.C.B..	9.
•Main Component Replacement Procedures	
1. Replacement for the regulator transistor.	9.

■ Checking Procedure for each P.C.B.

1. Checking for the operation P.C.B.

Step 2

Step 3

Remove the cabinet.

Step 1

Step 4

Step 5

Pull put the front panel ass'y.

• Check the operation P.C.B. as shown below.

Operation P.C.B. (Solder side)

① (Silver)

[RHD30007-S]

② (Black)

③ (Black)

[XTBS3+8JFZ1]

2. Checking for the PDM P.C.B.

• Follow **Step 1** ~ **Step 5** in item 1 on page 8.

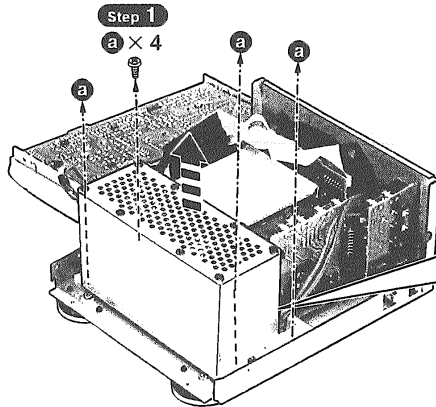

• Check the PDM P.C.B. as shown below.

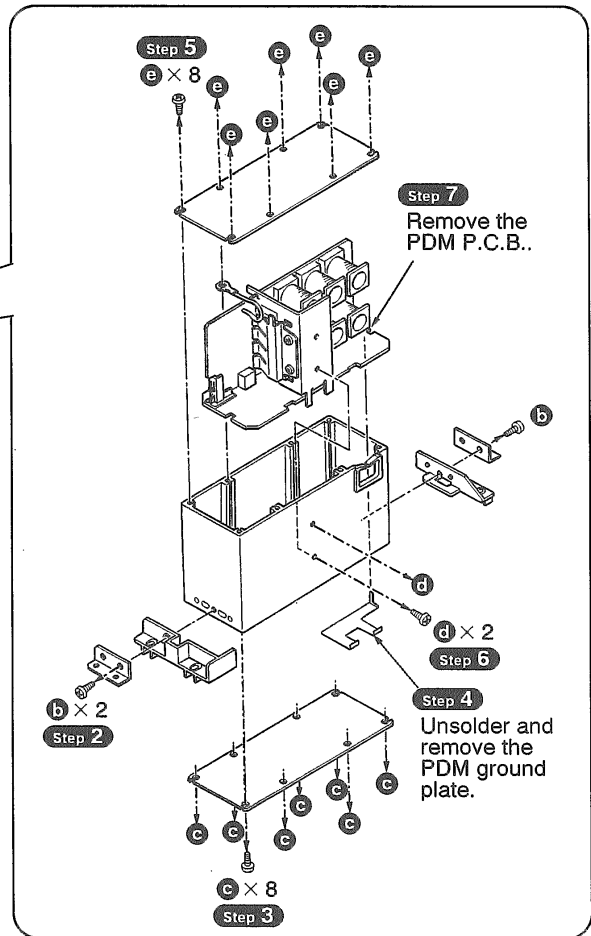
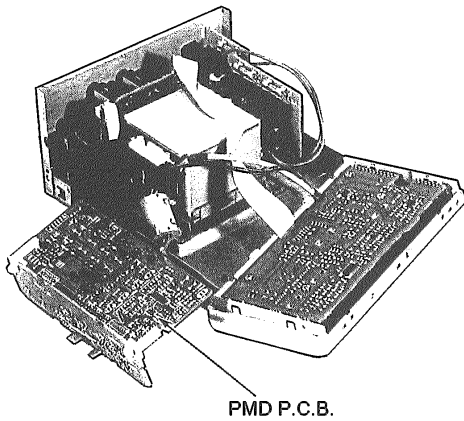

a, b (Black)
[XTBS3+8JFZ1]

c, d, e (Black)
[XTB3+6JFZ]

Main Component Replacement Procedures

1. Replacement for the regulator transistor

• Follow **Step 1** ~ **Step 5** in item 1 on page 8.
• Follow **Step 1** ~ **Step 7** in item 2 on page 9.

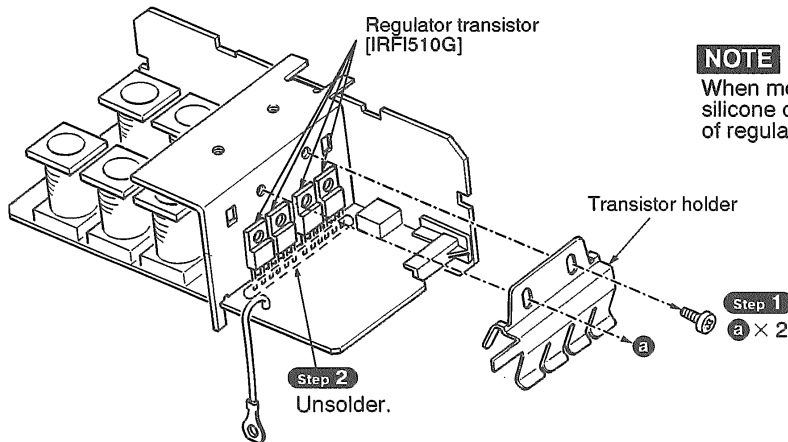

NOTE

When mounting the regulator transistor, apply silicone compound (RFKX0002) to the rear side of regulator transistor.

a (Black)
[XTB3+6JFZ]

POWER SOURCE ON/OFF OF THIS UNIT

1. Short the section between the points CN504 ⑤ pin (POWER) and CN503 ① pin (+5V).
2. Connect this unit to an AC outlet by the AC power cord.

Operation check

1. Set this unit to power ON mode.
2. Input a signal (1kHz, 100mV), and confirm it to be outputted from the speaker terminal.

	INPUT	OUTPUT
Lch	CN801 ⑩ pin ↔ CN801 ⑥ pin	Lch speaker terminal
Rch	CN801 ⑨ pin ↔ CN801 ⑥ pin	Rch speaker terminal

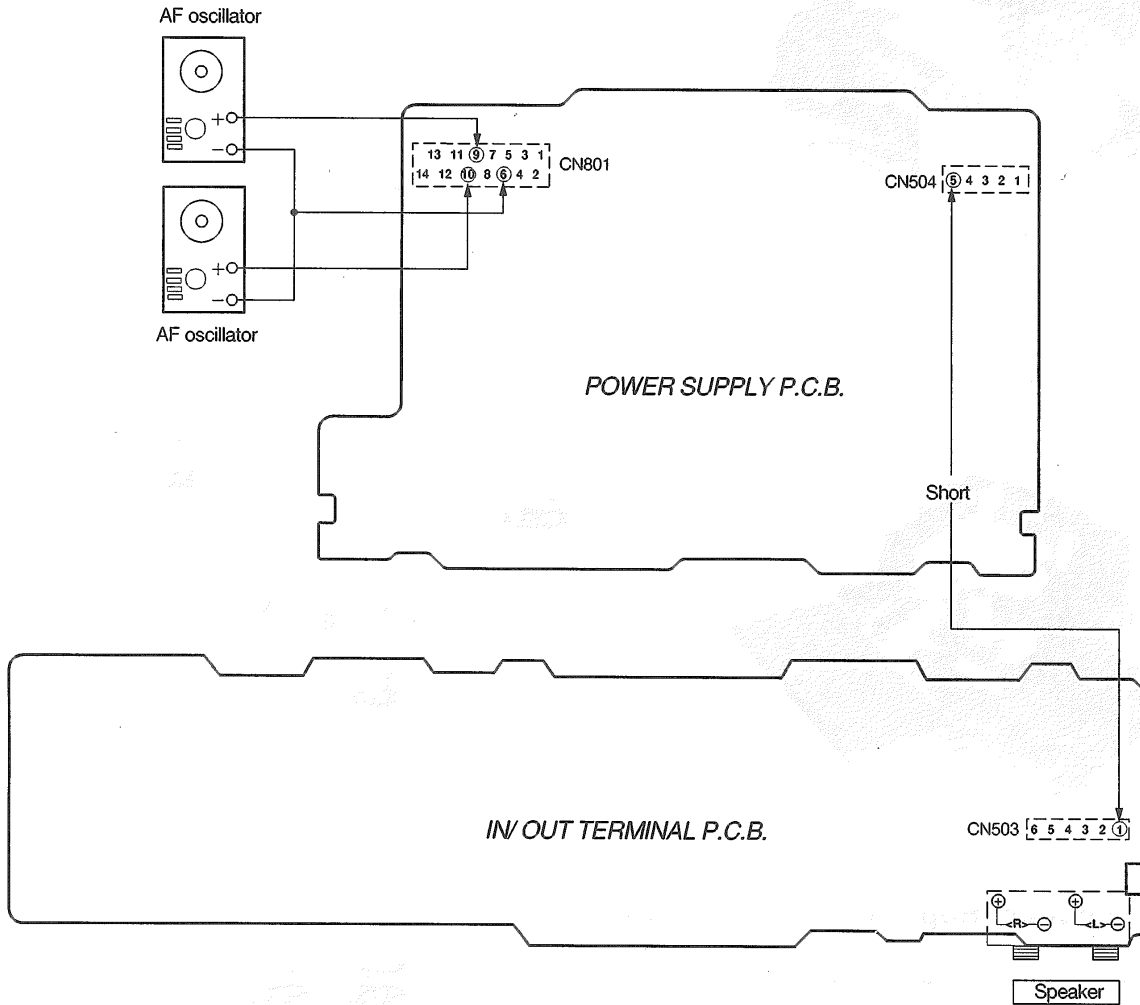

REPLACEMENT OF THE FOOT

1. Remove the 4 heat melted posts on the Bottom board ass'y with a pair of nippers or similar tool.
2. To replace the foot (RKA0076-N1) on the Bottom board ass'y melt the 4 posts with a soldering iron or install it with a screw (XTB3+6J).

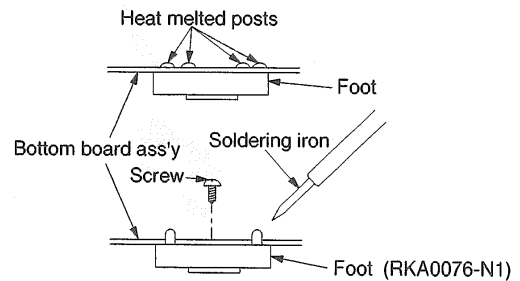

WIRING CONNECTION DIAGRAM

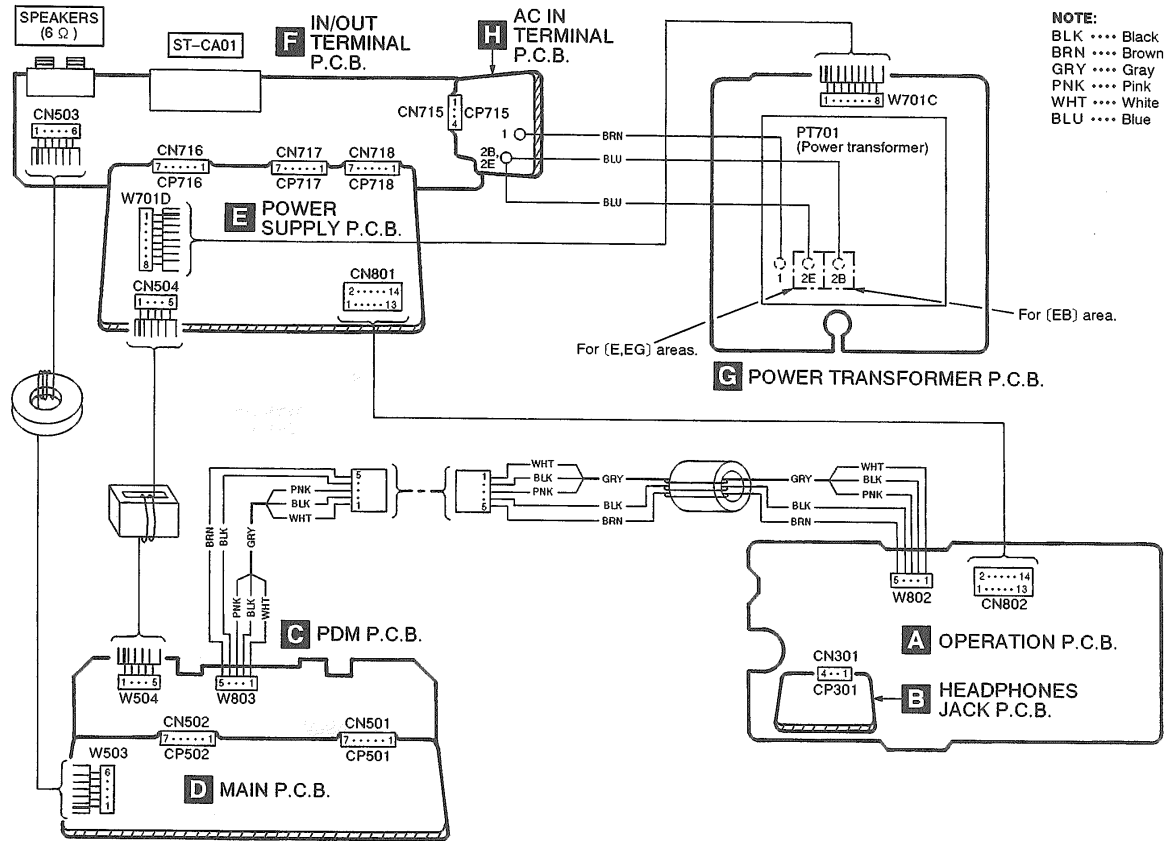

Terminal guide of IC's transistors and diodes

<p>No.1</p>	M5218AFPE3	8PIN	<p>IR2112</p>	<p>NJM2114D</p>	<p>TC74HC00AFT1 TC74HC74AFEL</p>
	M5219FPTA	8PIN			
	TC7WU04FT12L	8PIN			
	TC7W08FTE12L	8PIN			
	TC9215AFEL	16PIN			
<p>IRFI510G</p>	<p>2SD2137PQTA</p>		<p>2SC3312RSTA 2SC3311AIRTA UN4111AITA UN4115TA</p>	<p>2SB1218RTX 2SB792RSTTX 2SD1819RTX</p>	<p>2SD2144STA</p>
<p>MA8033LTX</p>	<p>MA4051MTA</p>	<p>MA165TA</p>	<p>1N5402BF RL1N4003N02 D1NL20U-4084</p>	<p>MA111TX</p>	
<p>MA4120HTA MA4150HTA MA4240MTA MA4300MTA</p>	<p>MA185TA</p>	<p>LNJ201LPQJA LNJ301MPUJAD</p>			

BLOCK DIAGRAM

● Signal line ➡ : Source signal ※ () indicates pin No. of right channel.

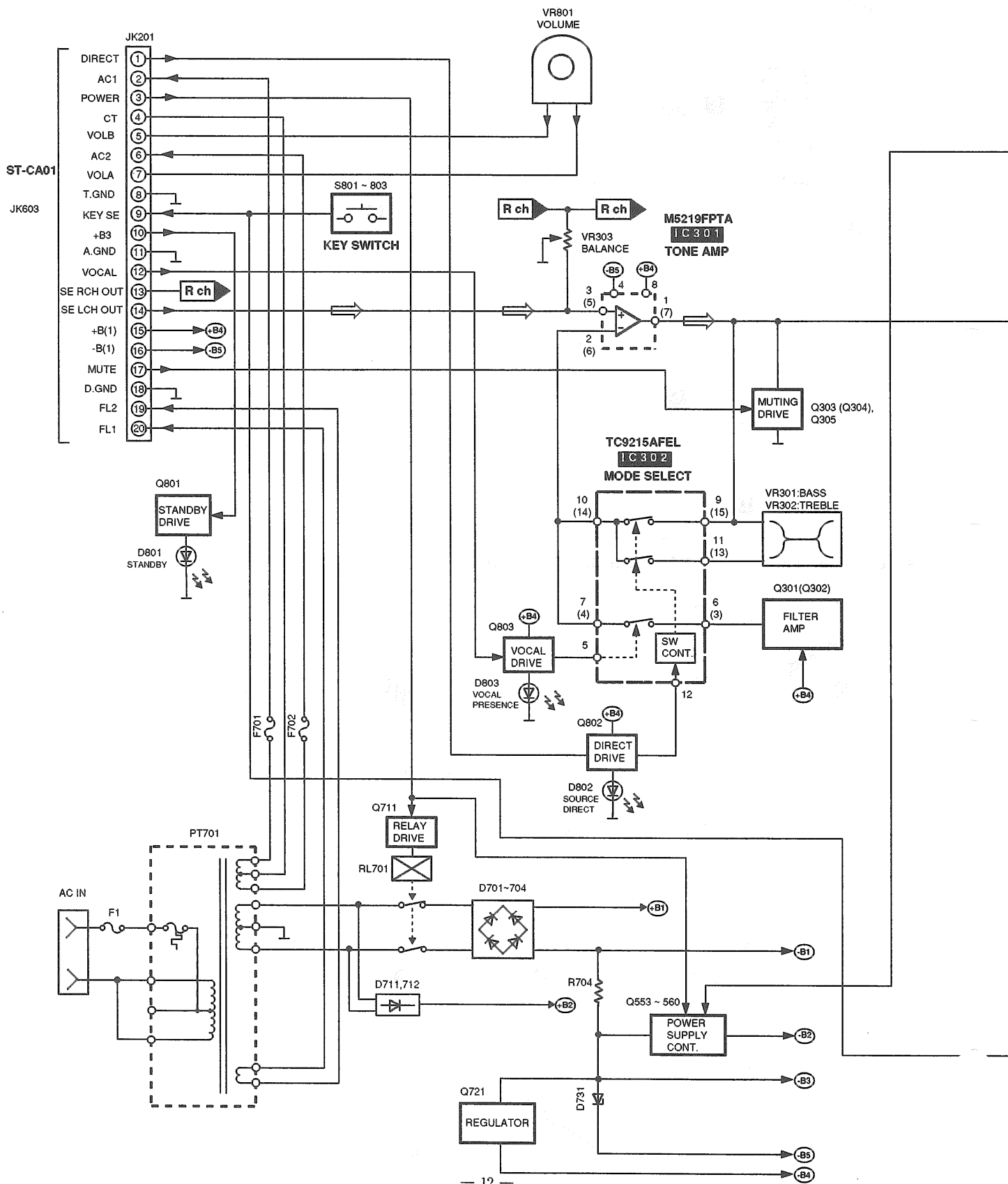

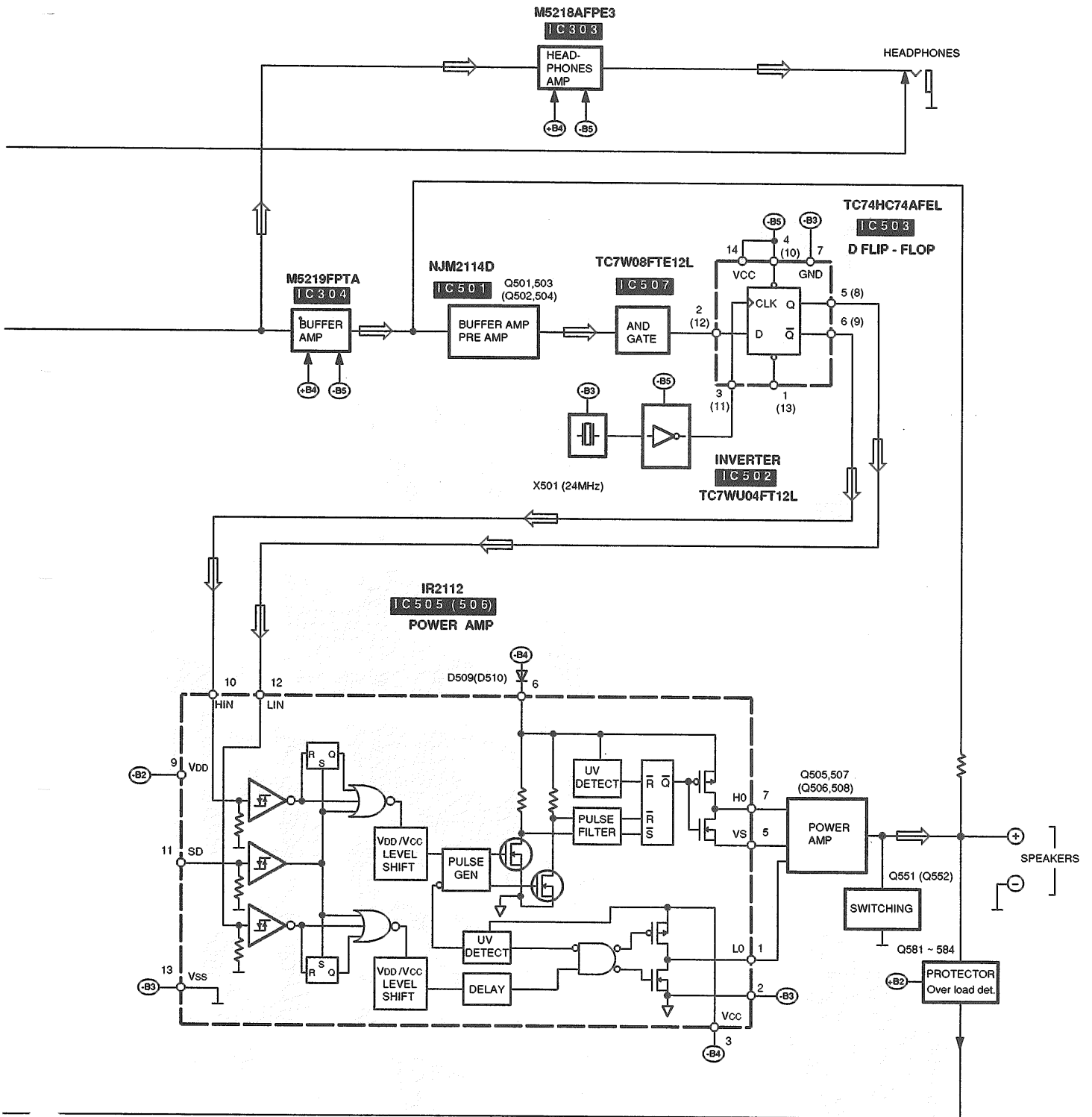

PRINTED CIRCUIT BOARD DIAGRAM

Notes:

- In this printed circuit board diagram, the parts and foil patterns on the board facing toward you are printed in black. The opposite side is printed in blue.
- The "●" mark denotes the connection points of double-faced foil patterns (through holes) on both side of the printed circuit board.

- This printed circuit board diagram may be modified at any time with the development of new technology.

C PDM P.C.B. (REP2293A-M)

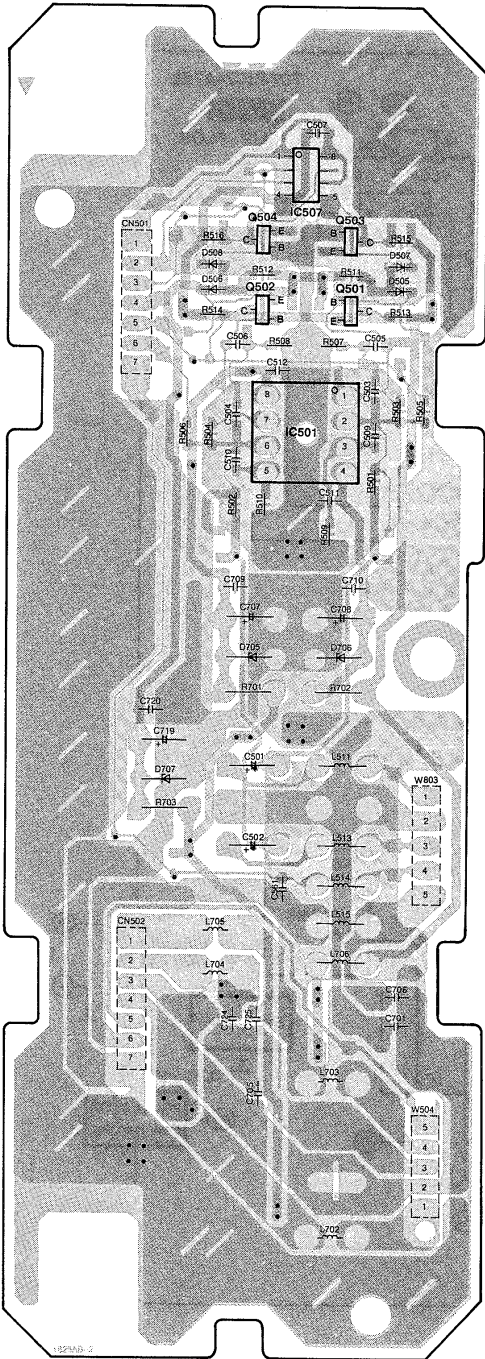

D MAIN P.C.B. (REP2293A-M)

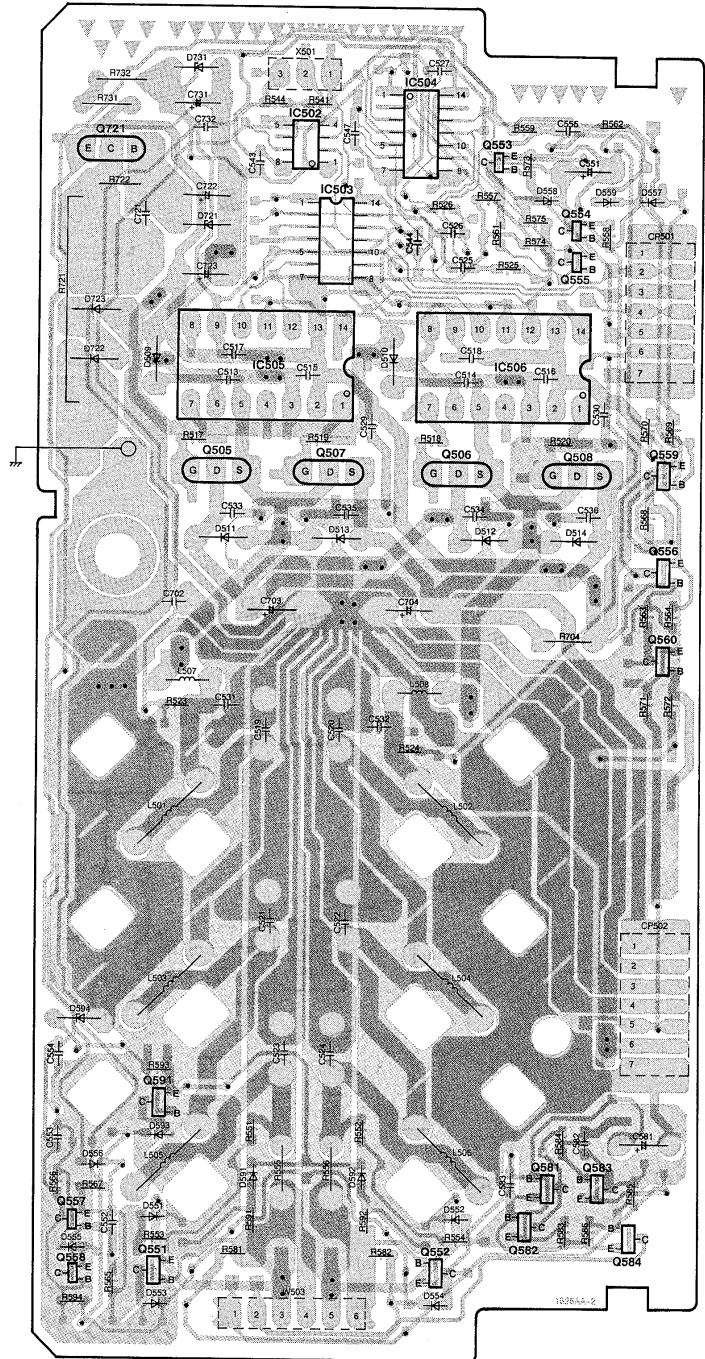

A OPERATION P.C.B. (REP2294B-S)

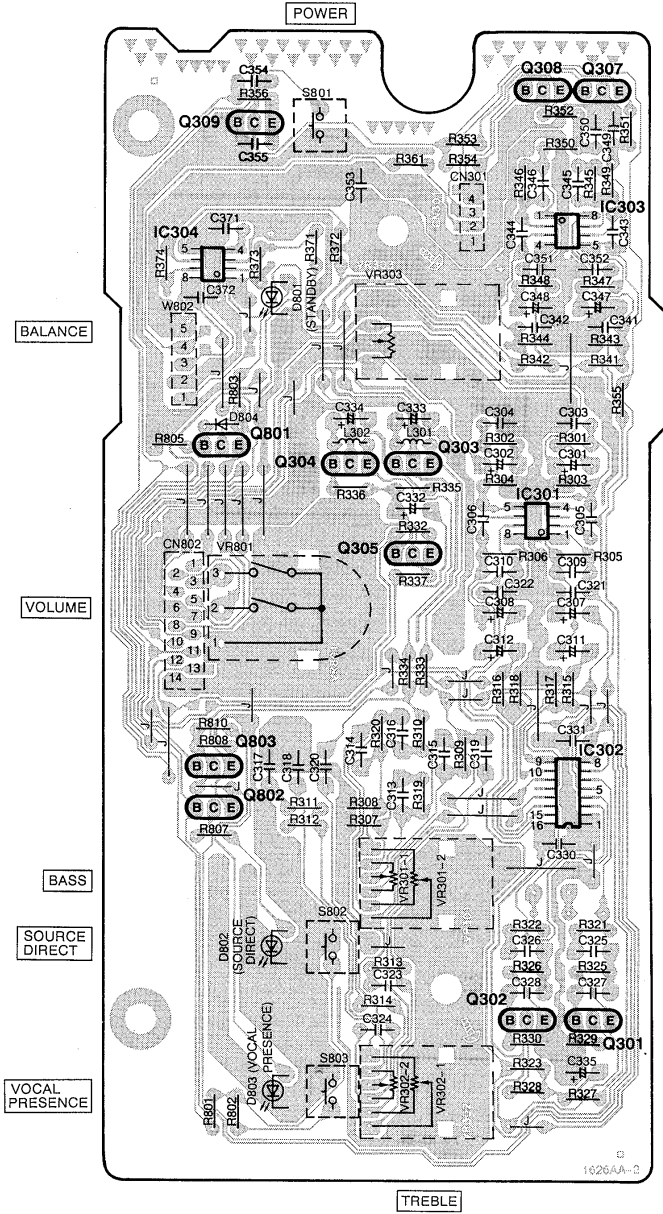

F IN/OUT TERMINAL P.C.B. (REP2295B-P...[E,EG] REP2295C-P...[EB])

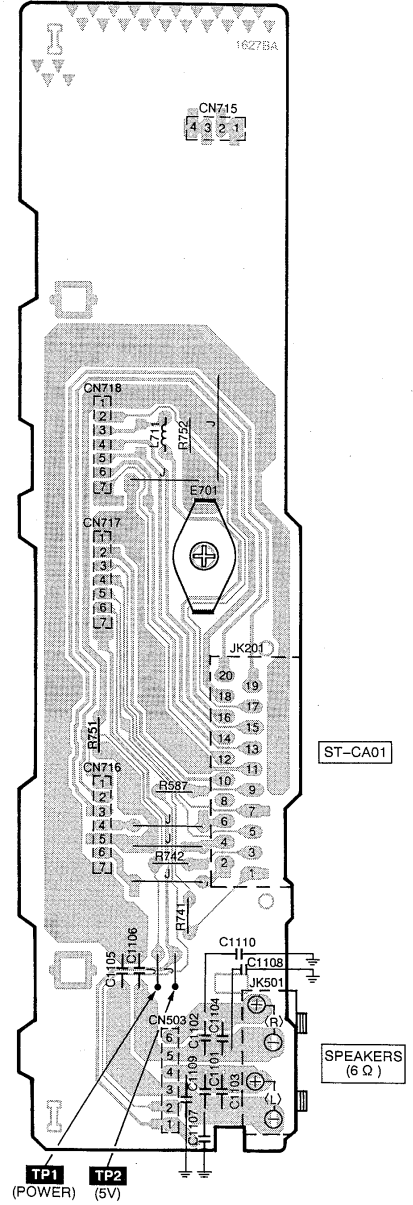

B HEADPHONES JACK P.C.B. (REP2294B-S)

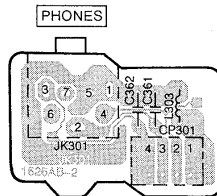

E POWER SUPPLY P.C.B.
 (REP2295B-P...[E,EG]
 REP2295C-P...[EB])

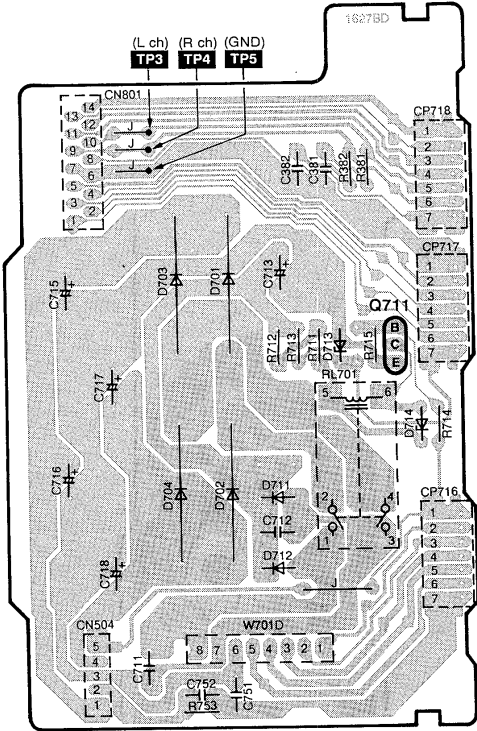

H AC IN
 TERMINAL P.C.B.
 (REP2295B-P...[E,EG]
 REP2295C-P...[EB])
 (230V...[E,EG]
 230V~240V...[EB]
 50Hz)

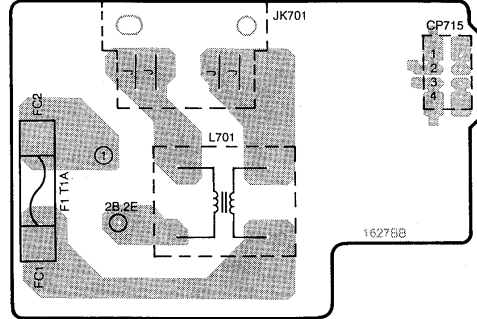

G POWER TRANSFORMER P.C.B.
 (REP2295B-P...[E,EG]
 REP2295C-P...[EB])

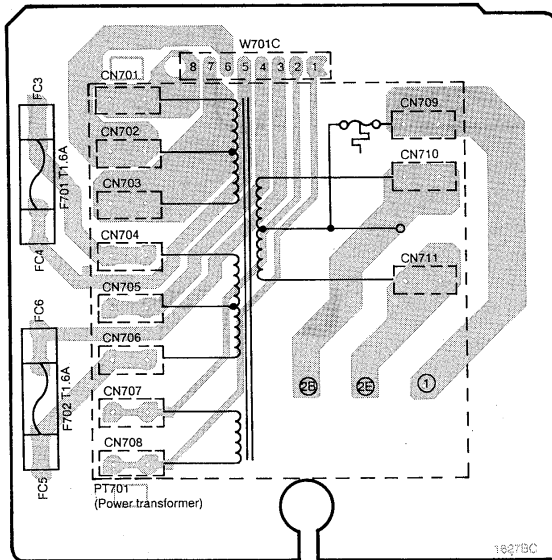

■ SCHEMATIC DIAGRAM (Parts list on pages 23, 24, 26, 27.)

● This schematic diagram may be modified at any time with the development of new technology.

	Page
A OPERATION CIRCUIT	18, 19
B HEADPHONES JACK CIRCUIT	18
C PDM CIRCUIT	19
D MAIN CIRCUIT	20, 21
E POWER SUPPLY CIRCUIT	22
F INPUT/OUTPUT TERMINAL CIRCUIT	22
G POWER TRANSFORMER CIRCUIT	22
H AC IN TERMINAL CIRCUIT	22

Notes:

- **S801:** Power "STANDBY \odot /ON" switch (POWER, STANDBY \odot /ON)
- **S802:** Source direct switch (SOURCE DIRECT)
- **S803:** Vocal presence switch (VOCAL PRESENCE)
- Indicated voltage values are the standard values for the unit measured by the DC electronic circuit tester (high-impedance) with the chassis taken as standard. Therefore, there may exist some errors in the voltage values, depending on the internal impedance of the DC circuit tester.
No mark: Power ON
- Important safety notice:
Components identified by \triangle mark have special characteristics important for safety.
Furthermore, special parts which have purposes of fire-retardant (resistors), high-quality sound (capacitors), low-noise (resistors), etc. are used.
When replacing any of components, be sure to use only manufacturer's specified parts shown in the parts list.
- **Caution!**
IC and LSI are sensitive to static electricity.
Secondary trouble can be prevented by taking care during repair.
Cover the parts boxes made of plastics with aluminum foil.
Ground the soldering iron.
Put a conductive mat on the work table.
Do not touch the legs of IC or LSI with the fingers directly.

● Voltage and signal line

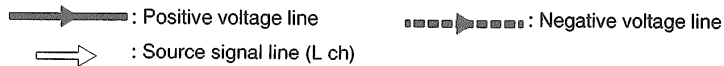

A OPERATION CIRCUIT (P.C.Board: on page 15)

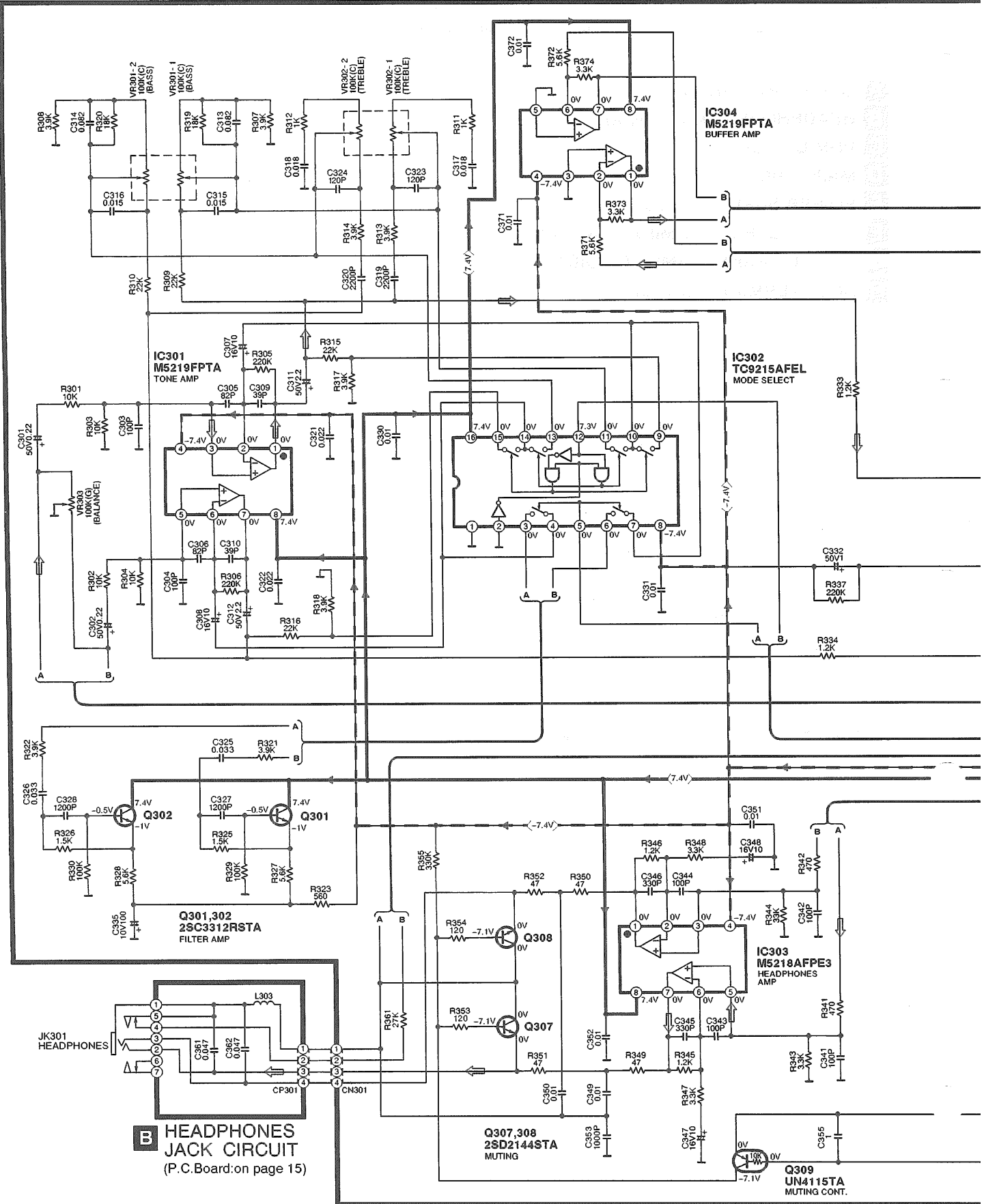

C PDM CIRCUIT (P.C.Board: on page 14)

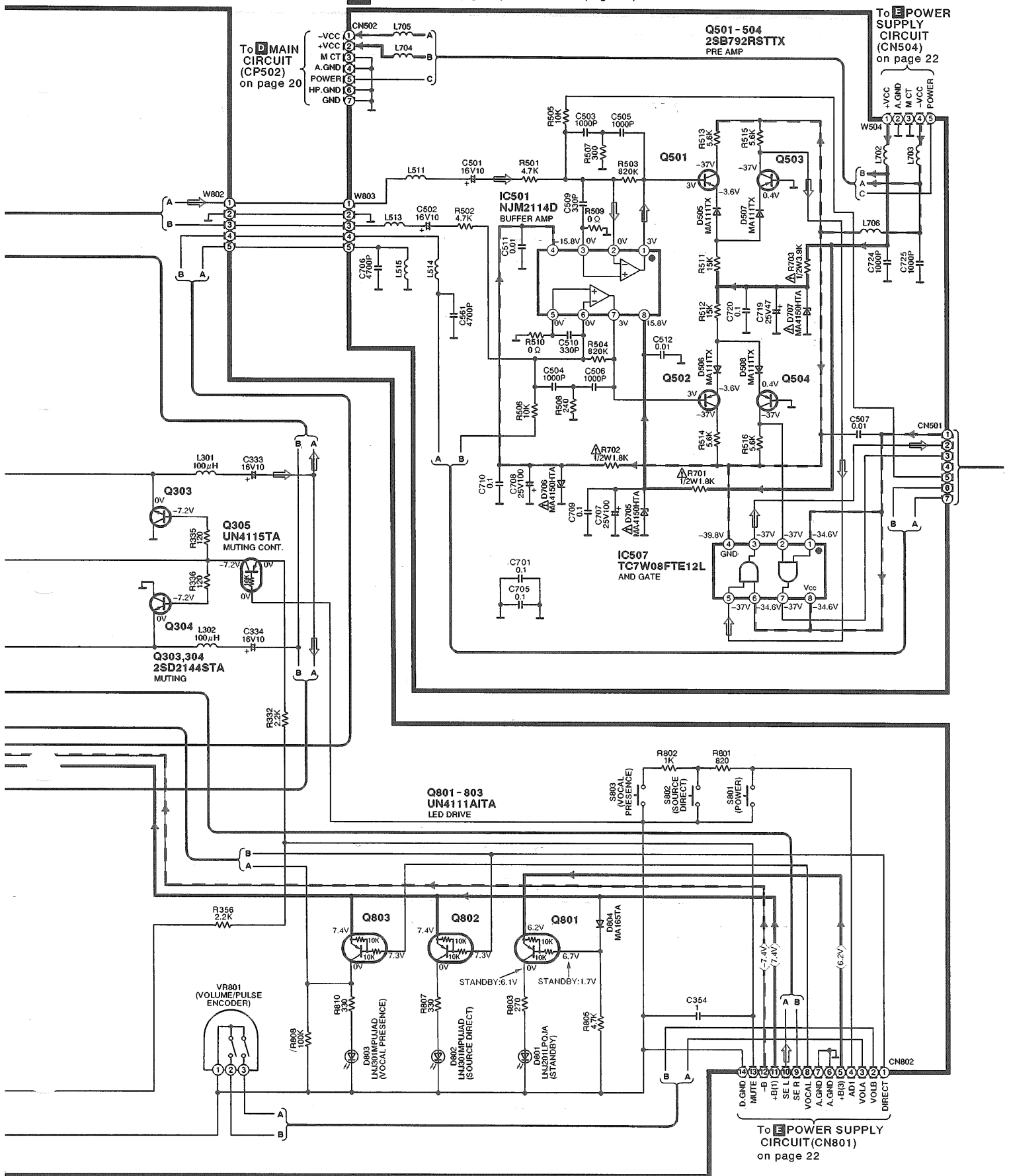

D MAIN CIRCUIT (P.C.Board: on page 14)

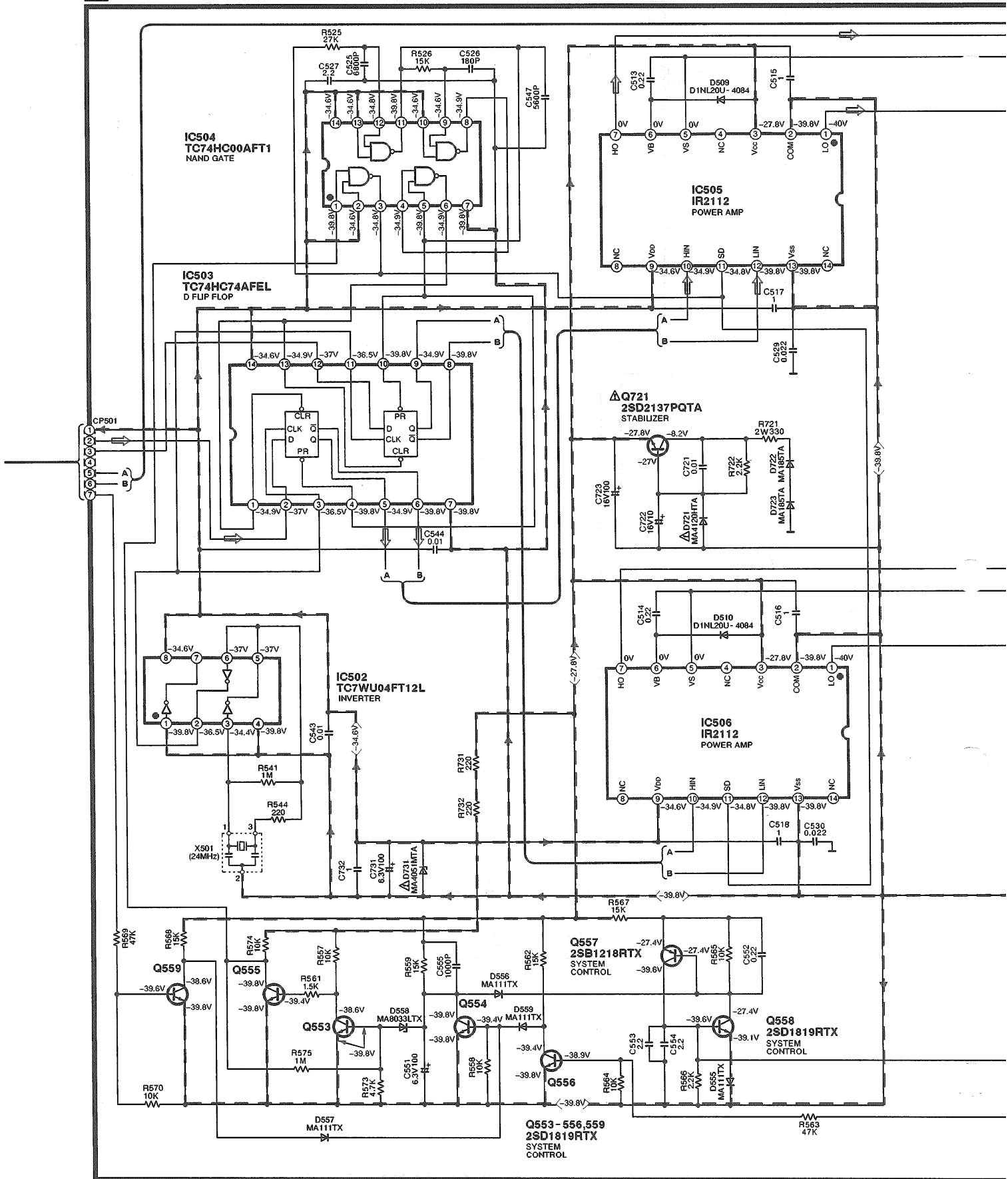

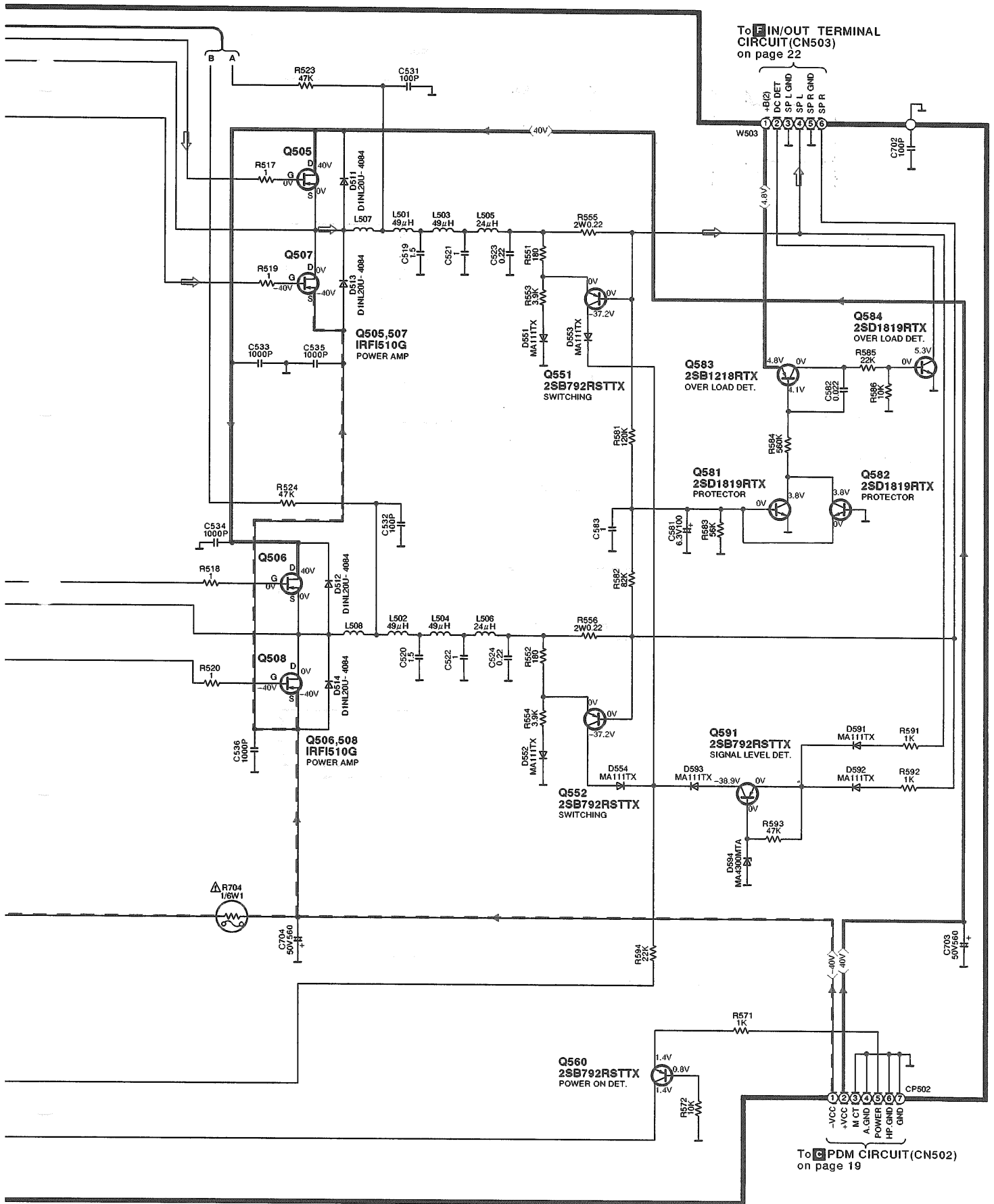

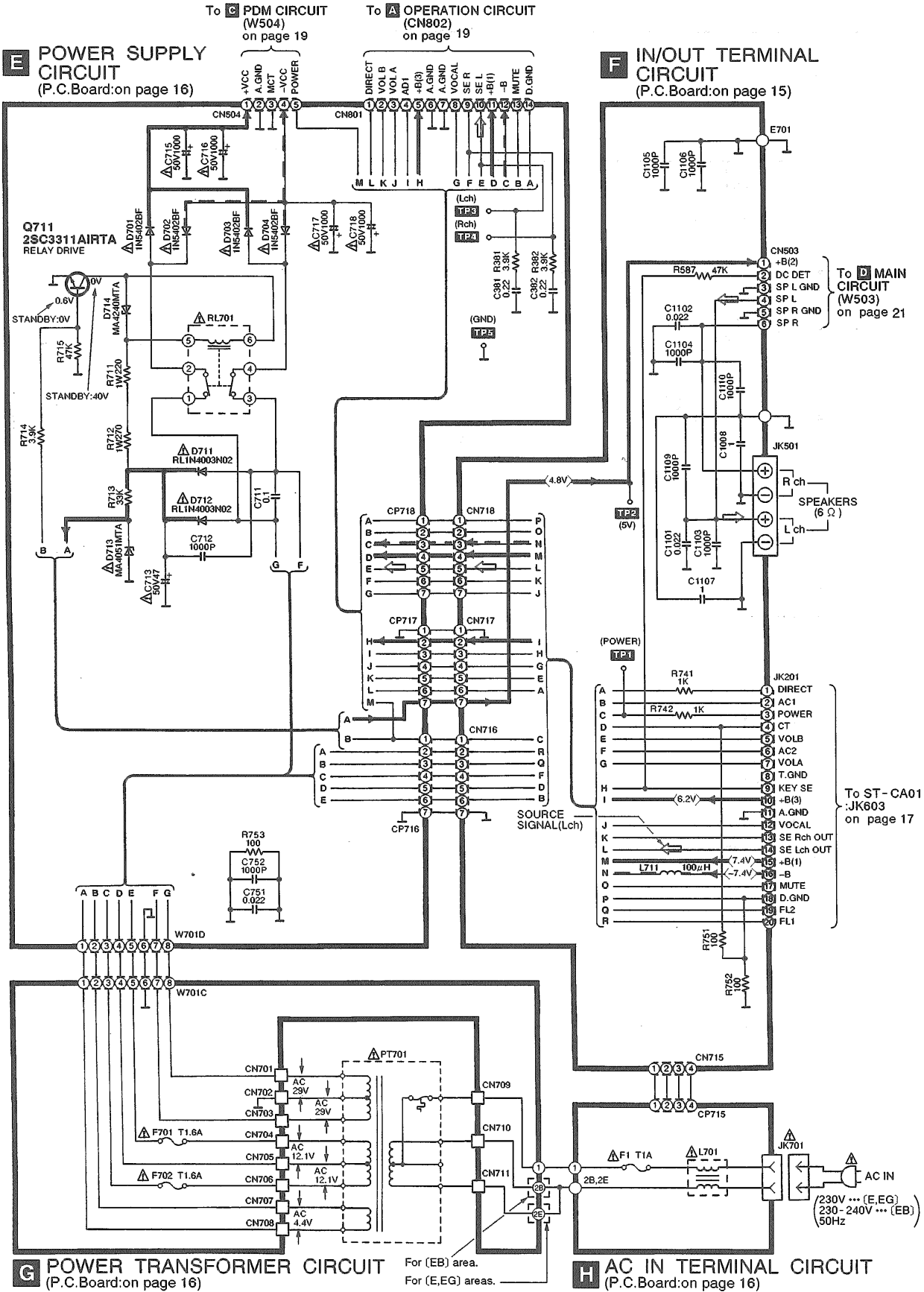

RESISTORS AND CAPACITORS

Notes: * Capacity values are in microfarads (uF) unless specified otherwise, P=Pico-farads (pF) F=Farads (F)
* Resistance values are in ohms, unless specified otherwise, 1K=1,000 (OHM), 1M=1,000k (OHM)

Ref. No.	Part No.	Values & Remarks	Ref. No.	Part No.	Values & Remarks	Ref. No.	Part No.	Values & Remarks
		RESISTORS	R557, 558	ERJ6GEYJ103V	1/10W 10K			CAPACITORS
			R559	ERJ6GEYJ153V	1/10W 15K			
			R561	ERJ6GEYJ152V	1/10W 1.5K			
R301-304	ERDS2TJ103	1/4W 10K	R562	ERJ6GEYJ153V	1/10W 15K	C301, 302	ECEA1HKAR22B	50V 0.22U
R305, 306	ERDS2TJ224T	1/4W 220K	R563	ERJ6GEYJ473V	1/10W 47K	C303, 304	ECBT1H101KB5	50V 100P
R307, 308	ERDS2TJ392T	1/4W 3.9K	R564, 565	ERJ6GEYJ103V	1/10W 10K	C305, 306	ECBT1H820KB5	50V 82P
R309, 310	ERDS2TJ223	1/4W 22K	R566	ERJ6GEYJ222V	1/10W 2.2K	C307, 308	RCE1CKA100BG	16V 10U
R311, 312	ERDS2TJ102	1/4W 1K	R567, 568	ERJ6GEYJ153V	1/10W 15K	C309, 310	ECBT1H390J5	50V 39P
R313, 314	ERDS2TJ392T	1/4W 3.9K	R569	ERJ6GEYJ473V	1/10W 47K	C311, 312	ECEA1HKA2R2B	50V 2.2U
R315, 316	ERDS2TJ223	1/4W 22K	R570	ERJ6GEYJ103V	1/10W 10K	C313, 314	ECQV1H823JM3	50V 0.082U
R317, 318	ERDS2TJ392T	1/4W 3.9K	R571	ERJ6GEYJ102V	1/10W 1K	C315, 316	ECQB1H153JF3	50V 0.015U
R319, 320	ERDS2TJ183T	1/4W 18K	R572	ERJ6GEYJ103V	1/10W 10K	C317, 318	ECQB1H183JF3	50V 0.018U
R321, 322	ERDS2TJ392T	1/4W 3.9K	R573	ERJ6GEYJ472V	1/10W 4.7K	C319, 320	ECQB1H222JF3	50V 2200P
R323	ERDS2TJ561	1/4W 560	R574	ERJ6GEYJ103V	1/10W 10K	C321, 322	ECBT1E223ZF	25V 0.022U
R325, 326	ERDS2TJ152	1/4W 1.5K	R575	ERJ6GEYJ105	1/10W 1M	C323, 324	ECBT1H121KB5	50V 120P
R327, 328	ERDS2TJ562	1/4W 5.6K	R581	ERJ6GEYJ124V	1/10W 120K	C325, 326	ECQV1H333JM3	50V 0.033U
R329, 330	ERDS2TJ104	1/4W 100K	R582	ERJ6GEYJ823	1/10W 82K	C327, 328	ECQB1H122JF3	50V 1200P
R332	ERDS2TJ222	1/4W 2.2K	R583	ERJ6GEYJ563V	1/10W 56K	C330, 331	ECBT1E103ZF	25V 0.01U
R333, 334	ERDS2TJ122	1/4W 1.2K	R584	ERJ6GEYJ564V	1/10W 560K	C332	ECEA1HKA010B	50V 1U
R335, 336	ERDS2EJ121	1/4W 120	R585	ERJ6GEYJ223V	1/10W 22K	C333, 334	RCE1CKA100BG	16V 10U
R337	ERDS2TJ224T	1/4W 220K	R586	ERJ6GEYJ103V	1/10W 10K	C335	RCE1AKA101BG	10V 100U
R341, 342	ERDS2TJ471	1/4W 470	R587	ERDS2TJ473	1/4W 47K	C341-344	ECBT1H101KB5	50V 100P
R343, 344	ERDS2TJ333	1/4W 33K	R591, 592	ERJ6GEYJ102V	1/10W 1K	C345, 346	ECBT1H331KB5	50V 330P
R345, 346	ERDS2TJ122	1/4W 1.2K	R593	ERJ6GEYJ473V	1/10W 47K	C347, 348	RCE1CKA100BG	16V 10U
R347, 348	ERDS2TJ332	1/4W 3.3K	R594	ERJ6GEYJ223V	1/10W 22K	C349-352	ECBT1E103ZF	25V 0.01U
R349-352	ERDS2TJ470	1/4W 47	R701, 702	ERDS1FVJ182T	1/2W 1.8K Δ	C353	ECBT1H102KB5	50V 1000P
R353, 354	ERDS2EJ121	1/4W 120	R703	ERDS1FVJ392T	1/2W 3.9K Δ	C354, 355	ECBT1C105ZF5	16V 1U
R355	ERDS2TJ334	1/4W 330K	R704	ERQ16NW1ROE	1W 1.0 Δ	C361, 362	ECBT1H473ZF5	50V 0.047U
R356	ERDS2TJ222	1/4W 2.2K	R711	ERG1SJ221E	1W 220	C371, 372	ECBT1E103ZF	25V 0.01U
R361	ERDS2TJ273	1/4W 27K	R712	ERG1SJ271E	1W 270	C381, 382	ECQV1H224JM3	50V 0.22U
R371, 372	ERDS2TJ562	1/4W 5.6K	R713	ERDS2TJ333	1/4W 33K	C501, 502	RCE1CKA100BG	16V 10U
R373, 374	ERDS2TJ332	1/4W 3.3K	R714	ERDS2TJ392T	1/4W 3.9K	C503-506	ECUV1H102KBN	50V 1000P
R381, 382	ERDS2TJ392T	1/4W 3.9K	R715	ERDS2TJ473	1/4W 47K	C507	ECUV1E103ZFN	25V 0.01U
R501, 502	ERJ6GEYJ472V	1/10W 4.7K	R721	ERG2ANJP331S	2W 330	C509, 510	ECUV1H331KBN	50V 330P
R503, 504	ERJ6GEYJ824V	1/10W 820K	R722	ERDS2TJ222	1/4W 2.2K	C511, 512	ECUV1E103ZFN	25V 0.01U
R505, 506	ERJ6GEYJ103V	1/10W 10K	R731, 732	ERDS2TJ221	1/4W 220	C513, 514	ECUV1E224ZFN	25V 0.22U
R507	ERJ6GEYJ301V	1/10W 300	R741, 742	ERDS2TJ102	1/4W 1K	C515-518	ECUVNC105ZFN	16V 1U
R508	ERJ6GEYJ241V	1/10W 240	R751-753	ERDS2TJ101	1/4W 100	C519, 520	ECQV1H155JL3	50V 1.5U
R511, 512	ERJ6GEYJ153V	1/10W 15K	R801	ERDS2TJ821	1/4W 820	C521, 522	ECQV1H105JM3	50V 1U
R513-516	ERJ6GEYJ562V	1/10W 5.6K	R802	ERDS2TJ102	1/4W 1K	C523, 524	ECQV1H224JM3	50V 0.22U
R517-520	ERJ6GEYJ1ROV	1/10W 1.0	R803	ERDS2TJ271	1/4W 270	C525	ECUV1H682KBN	50V 6800P
R523, 524	ERJ6GEYJ473V	1/10W 47K	R805	ERDS2TJ472	1/4W 4.7K	C526	ECUV1H181KCN	50V 180P
R525	ERJ6GEYJ273V	1/10W 27K	R807	ERDS2TJ331	1/4W 330	C527	ECUVNC225ZFN	16V 2.2U
R526	ERJ6GEYJ153V	1/10W 15K	R808	ERDS2TJ104	1/4W 100K	C529, 530	ECUV1H223ZFN	50V 0.022U
R541	ERJ6GEYJ105	1/10W 1M	R810	ERDS2TJ331	1/4W 330	C531, 532	ECUV2H101JCM	500V 100P
R544	ERJ6GEYJ221V	1/10W 220			CHIP JUMPERS	C533-536	ECUV1H102KBN	50V 1000P
R551, 552	ERJ6GEYJ181V	1/10W 180				C543, 544	ECUV1E103ZFN	25V 0.01U
R553, 554	ERJ6GEYJ392V	1/10W 3.9K				C547	ECUV1H562KBN	50V 5600P
R555, 556	ERF2EXKR22V	2W 0.22	R509, 510	ERJ6GEYOR00V	CHIP JUMPER	C551	ECEAOJKA101B	6.3V 100U

Ref. No.	Part No.	Values & Remarks	Ref. No.	Part No.	Values & Remarks	Ref. No.	Part No.	Values & Remarks
C552	ECUV1E224ZFN	25V 0.22U	C707, 708	ECA1EM101B	25V 100U	C722	RCE1CKA100BG	16V 10U
C553, 554	ECUVNC225ZFN	16V 2.2U	C709, 710	ECUV1E104ZFN	25V 0.1U	C723	ECEA1CKA101B	16V 100U
C555	ECUV1H102KBN	50V 1000P	C711	ECQE1104KF3	100V 0.1U	C724, 725	ECUV1H102KBN	50V 1000P
C561	ECUV1H472KBN	50V 4700P	C712	ECKR2H102ZF5	500V 1000P	C731	ECEAOJKA101B	6.3V 100U
C581	ECEAOJKA101B	6.3V 100U	C713	ECA1HM470B	50V 47U Δ	C732	ECUVNC105ZFN	16V 1U
C582	ECUV1E223ZFN	25V 0.022U	C715	ECA1HM102E	50V 1000U Δ	C751	ECBT1E223ZF	25V 0.022U
C583	ECUVNC105ZFN	16V 1U	C716	ECA1HM102B	50V 1000U Δ	C752	ECBT1H102KB5	50V 1000P
C701	ECUV1E104ZFN	25V 0.1U	C717	ECA1HM102E	50V 1000U Δ	C1101, 1102	ECBT1E223ZF	25V 0.022U
C702	ECUV1H101KCN	50V 100P	C718	ECA1HM102B	50V 1000U Δ	C1103-1106	ECBT1H102KB5	50V 1000P
C703, 704	EEUFA1H561E	50V 560U	C719	ECEA1EKA470B	25V 47U	C1107, 1108	ECBT1C105ZF5	16V 1U
C705	ECUV1E104ZFN	25V 0.1U	C720	ECUV1E104ZFN	25V 0.1U	C1109, 1110	ECBT1H102KB5	50V 1000P
C706	ECUV1H472KBN	50V 4700P	C721	ECUV1E103ZFN	25V 0.01U			

REPLACEMENT PARTS LIST

Notes: * The parenthesized indications in the Remarks columns specify the areas. (Refer to the cover page for area.) Parts without these indications can be used for all areas.

Ref. No.	Part No.	Part Name & Description	Remarks	Ref. No.	Part No.	Part Name & Description	Remarks
		CABINET AND CHASSIS		21	RMR0985-K	EDGE HOLDER	
				22	RMX0118	PDM SPACER (L)	
				23	RMX0123	PDM SPACER (R)	
1	RHD30007-S	SCREW		24	RSCD448	PDM COVER	
2	RMMD326C-S	CABINET		25	RSCD458	PDM EARTH BRACKET	
3	XTBS3+8JFZ1	SCREW		26	XTB3+6JFZ	SCREW	
4	RSCD457	SHIELD BRACKET		27	REZD902	CONNECTOR ASS'Y (5P) (W802)	
5	RWJ1808165KK	FLAT CABLE (8P) (W701)		28	REZD900	FLAT CABLE (14P) (CN801, 802)	
6	RGRD241A-C1	REAR PANEL	(E, EG)	29	RFKGECA01E-N	FRONT PANEL ASS'Y	
6	RGRD241A-D1	REAR PANEL	(EB)	30	RGK0812-S	SIDE ORNAMENT (L)	
7	RGWD247-S1	VOLUME KNOB		31	RGK0813-S	SIDE ORNAMENT (R)	
8	RFKJEHD7-N	BOTTOM CHASSIS ASS'Y		32	RGK0815-N	VOLUME ORNAMENT	
8-1	RKAD076-N1	FOOT		33	RGL0333-1Q	PANEL LIGHT	
9	RMNO191	TRANSFORMER P. C. B. HOLDER		34	RGU1392-S	POWER BUTTON	
10	RMNO203	P. C. B. HOLDER		35	RGU1393-Q	OPERATION BUTTON	
11	RFKEEHD7-N	CONNECTOR UNIT (5P) (W803)		36	RGWD198-S	ADJUSTMENT KNOB	
12	RWJ1806380QQ	FLAT CABLE (6P) (W503)		37	RHD26016	SCREW	
13	RWJ5705300KX	FLAT CABLE (5P) (W504)		38	SNE4021-1	NUT	
14	RLBT3101-D	FERRITE CORE (6P)		39	XTBS26+8J	SCREW	
15	RLBT4001-D	FERRITE CORE (5P)		40	SHE185-2	P. C. B. SUPPORT	
16	RLB0010	FERRITE CORE (S)		41	XTB3+16JFZ	SCREW	
17	RMA0981	EARTH ANGLE		42	RJS1A5506	CABLE HOLDER (W503)	
18	RMCO302	STABILIZER		43	RMZD397	BARRIER	
19	RMFO236	SHEET		44	RJS2A1305	CABLE HOLDER (W504)	
20	RMRO322	PDM CHASSIS					

■ CABINET PARTS LOCATION

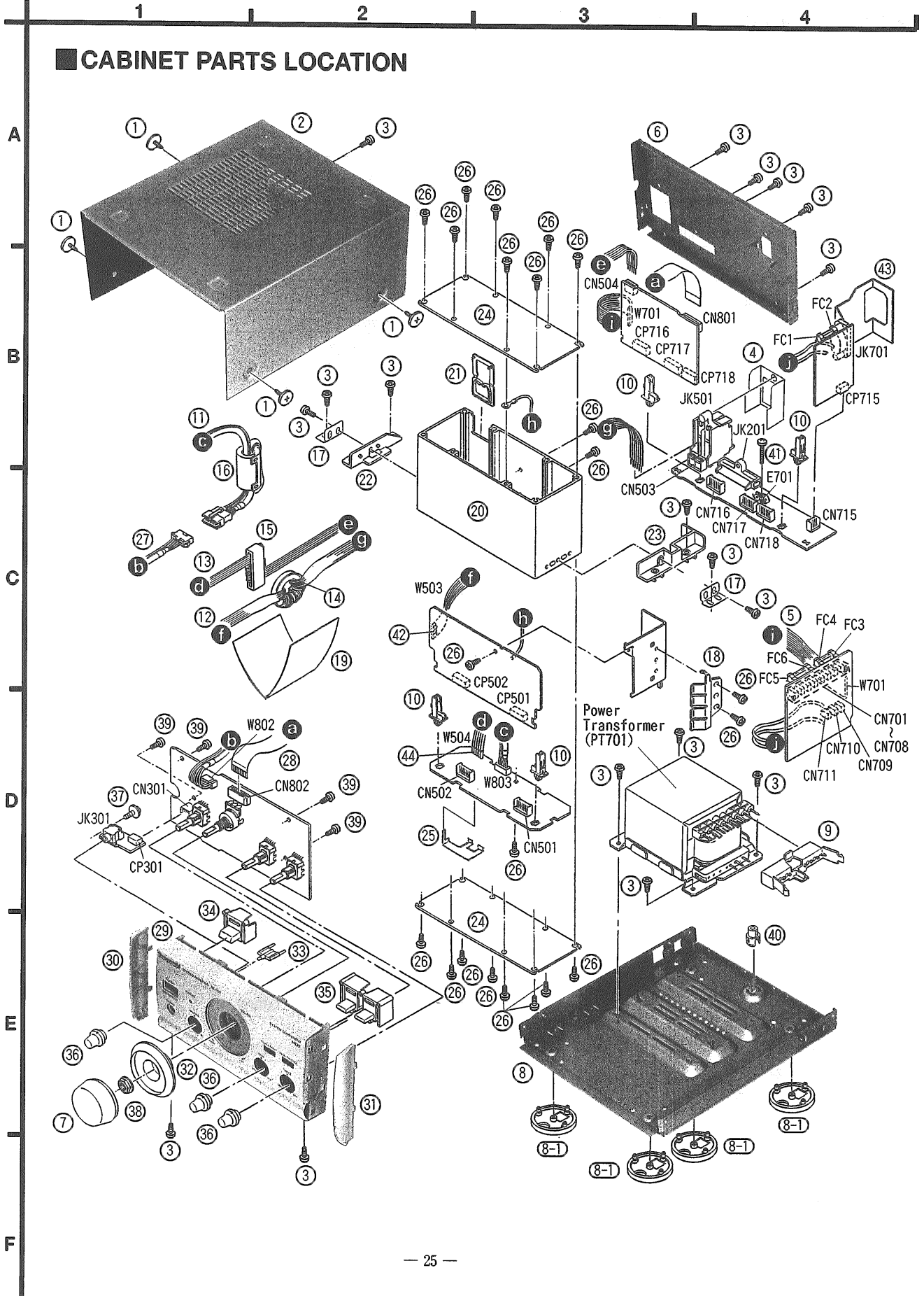

REPLACEMENT PARTS LIST

Notes:

- Important safety notice: Components identified by Δ mark have special characteristics important for safety. Furthermore, special parts which have purposes of fire-retardant (resistors), high-quality sound (capacitors), low-noise (resistors), etc. are used. When replacing any of components, be sure to use only manufacturer's specified parts shown in the parts list.
- The parenthesized indications in the Remarks columns specify the areas. (Refer to the cover page for area.)
- Parts without these indications can be used for all areas.
- Remote Control Ass'y: Supply period for three years from termination of production.
- The "(SF)" mark denotes the standard part.
- [V] indicates in Remarks columns parts that are supplied by Video Recorder Division.

Ref. No.	Part No.	Part Name & Description	Remarks	Ref. No.	Part No.	Part Name & Description	Remarks
		INTEGRATED CIRCUIT(S)		D711, 712	RL1M4003N02	DIODE	Δ
				D713	MA4051MTA	DIODE	Δ
				D714	MA4240H	DIODE	
IC301	M5219FPPTA	TONE AMP		D721	MA4120HTA	DIODE	Δ
IC302	TC9215AFEL	MODE SELECTOR		D722, 723	MA185TA	DIODE	
IC303	M5218AFPE3	HEADPHONES AMP		D731	MA4051MTA	DIODE	Δ
IC304	M5219FPPTA	BUFFER AMP		D801	LNJ201LPQJA	L. E. D.	
IC501	NJM2114D	BUFFER AMP		D802, 803	LNJ301MPUJAD	L. E. D.	
IC502	TC7WU04FT12L	INVERTER		D804	MA165	DIODE	
IC503	TC74HC74AFEL	D FLIP-FLOP				VARIABLE RESISTOR(S)	
IC504	TC74HC00AFT1	NAND GATE					
IC505, 506	IR2112	POWER AMP		VR301, 302	EVJYA1F04C15	BASS/TREBLE CONTROL	
IC507	TC7W08FTE12L	AND GATE		VR303	EVJ02QF04G15	BALANCE CONTROL	
		TRANSISTOR(S)		VR801	EVQWQAF2524B	VOLUME CONTROL	
						COIL(S)	
Q301, 302	2SC3312RSTA	TRANSISTOR		L301, 302	ELEXT101KA9	COIL	
Q303, 304	2SD2144S	TRANSISTOR		L303	RL500050T-Y	COIL	
Q305	UN4115	TRANSISTOR		L501	RLQT490K-V	COIL	
Q307, 308	2SD2144S	TRANSISTOR		L502	RLQT490K1-V	COIL	
Q309	UN4115	TRANSISTOR		L503	RLQT490K-V	COIL	
Q501-504	2SB792RSTTX	TRANSISTOR		L504	RLQT490K1-V	COIL	
Q505-508	IRF1510G	TRANSISTOR		L505, 506	RLQT240K-V	COIL	
Q551, 552	2SB792RSTTX	TRANSISTOR		L507, 508	BL02RN1R62T2	COIL	
Q553-556	2SD1819RTX	TRANSISTOR		L511	BL02RN2R62T4	COIL	
Q557	2SB1218RTX	TRANSISTOR		L513-515	BL02RN2R62T4	COIL	
Q558, 559	2SD1819RTX	TRANSISTOR		L701	RLQZ271M	COIL	Δ
Q560	2SB792RSTTX	TRANSISTOR		L702-706	BL02RN2R62T4	COIL	
Q581, 582	2SD1819RTX	TRANSISTOR		L711	ELEXT101KA9	COIL	
Q583	2SB1218RTX	TRANSISTOR				TRANSFORMER(S)	
Q584	2SD1819RTX	TRANSISTOR		PT701	RTP2M5B010	POWER TRANSFORMER	Δ
Q591	2SB792RSTTX	TRANSISTOR				OSCILLATOR(S)	
Q711	2SC3311AIRTA	TRANSISTOR					
Q721	2SD2137PQTA	TRANSISTOR	Δ	X501	EF0EC2405T4	OSCILLATOR (24MHz)	
Q801-803	UN4111	TRANSISTOR				FUSE(S)	
		DIODE(S)					
D505-508	MA111TX	DIODE		F1	XBA2C10TB0	FUSE, 250V 1A	Δ
D509-514	D1NL20U-4084	DIODE		F701, 702	XBA2C16TB0	FUSE, 250V 1.6A	Δ
D551-557	MA111TX	DIODE				SWITCH(ES)	
D558	MA8033LTX	DIODE					
D559	MA111TX	DIODE					
D591-593	MA111TX	DIODE					
D594	MA4300M	DIODE					
D701-704	1N5402BF	DIODE	Δ				
D705-707	MA4150M	DIODE	Δ				

Ref. No.	Part No.	Part Name & Description	Remarks	Ref. No.	Part No.	Part Name & Description	Remarks
S801	EVQ21405R	POWER					
S802	EVQ21405R	SOURCE DIRECT				PACKING MATERIAL	
S803	EVQ21405R	VOCAL PRESENCE					
		RELAY(S)		P1	RPG2979	PACKING CASE (SYSTEM)	
				P2	RPG3032	PACKING CASE (AMPLIFIER)	
				P2	RPG3035	PACKING CASE (TUNER)	
RL701	RSY0013M-0	RELAY	△	P2	RPG3034	PACKING CASE (CD)	
		CONNECTOR(S) AND SOCKET(S)		P2	RPG3033	PACKING CASE (DECK)	
				P3	RPN0971	CUSHION (TUNER/CD)	
CN301	RJT057W004-1	CONNECTOR (4P)		P3	RPN0970	CUSHION (AMPLIFIER/DECK)	
CN501, 502	RJT057W007-1	CONNECTOR (7P)		P4	RPQ0164	PAD	
CN503	RJS1A6606	CONNECTOR (6P)		P5	RPQ0604	SPACER	
CN504	RJS5T7ZA	CONNECTOR (5P)		P6	RPF0139	PROTECTION BAG (F. B.)	
CN701-711	RJS1A1101T1	CONNECTOR (1P)		P7	SPP740	PROTECTION BAG (UNIT)	
CN715	RJT057W004-1	CONNECTOR (4P)				ACCESSORIES	
CN716-718	RJT057W007-1	CONNECTOR (7P)					
CN801, 802	RJS1A6714	CONNECTOR (14P)		A1	RFKSECA01E-N	INSTRUCTION MANUAL ASS'Y	(E)
CP301	RJU057W004	SOCKET (4P)		A1	RFKSECA01EBN	INSTRUCTION MANUAL ASS'Y	(EB)
CP501, 502	RJU057W007	SOCKET (7P)		A1	RQT3503-D	INSTRUCTION MANUAL	(EG)
CP715	RJU057W004	SOCKET (4P)		A2	REX0608	FLAT CABLE (short) (20P)	
CP716-718	RJU057W007	SOCKET (7P)		A3	REX0812	FLAT CABLE (long) (19P)	
JK201	RJT065K20	CONNECTOR (20P)		A4	REX0813	FLAT CABLE (middle) (15P)	
		JACK(S) AND TERMINAL(S)		A5	RFA0737-R	SPEAKER CORD UNIT	
				A6	RJA0019-2K	AC POWER SUPPLY CORD	(E, EG) △ (SF)
JK301	RJJ37TN01-C	HEADPHONES		A6	VJA0733	AC POWER SUPPLY CORD	(EB) △ (SF) [V]
JK501	RJR0054	SPEAKERS		A7	RAK-CH193WH	REMOTE CONTROL TRANSMITTER	
JK701	SJS9236	AC INLET	△	A7-1	RKK0057-K	BATTERY COVER FOR R. C. T.	
		EARTH PLATE(S)		A8	RQA0117	WARRANTY CARD	
				A9	RQCB0169	SERVICENTER LIST	
E701	SNE1004-2	EARTH PLATE		A10	RSA0007	FM INDOOR ANTENNA	
		FUSE HOLDER(S)		A11	RSA0012	AM LOOP ANTENNA	
				A11-1	RMN0244	ANTENNA HOLDER	
FC1-6	EYF52BC	FUSE HOLDER		A11-2	XTN3+12AFZ	SCREW	
				A12	SJP9009	ATTACHMENT PLUG	(EB) △
						<GREASE OR JIG/TOOL>	
						GREASE	
				SA1	RFKX0002	COMPOUND GREASE	

■ PACKAGING

