

Service Manual

Amplifier

Amplifier

SE-CH510

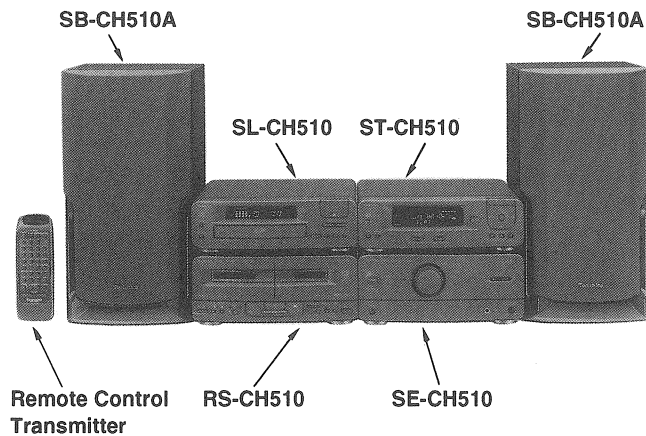

Colour

(K) Black Type

Areas

Suffix for Model No.	Area	Colour
(E)	Europe	(K)
(EB)	Great Britain	
(EG)	Germany and Italy	
(GC)	Asia, Latin America, Middle Near East and Africa	
(GN)	Oceania	

Because of unique interconnecting cables, when a component requires service, send or bring in the entire system.

System: SC-CH510

Specifications

Power output		
DIN 1 kHz, THD 1%, both channel driven		2 × 35 W (6Ω)
Total harmonic distortion		
Rated power at 1 kHz		1% (6Ω)
Half power at 1 kHz		0.09% (6Ω)
Load impedance		
MAIN		6Ω
S/N (rated power)		
MAIN		84 dB
Frequency response		
MAIN		40 Hz – 30 kHz

■ **General**

Power consumption	128 W
Power supply	
For (E) and (EG) areas	50 Hz/60 Hz AC, 230 V
For (EB) and (GN) areas	50 Hz/60 Hz AC, 230 V – 240 V
For (GC) area only	50 Hz/60 Hz AC, 110 V/127 V/220 V/240V
Dimensions (W × H × D)	270 × 118.5 × 339.5 mm
Weight	
For (E), (EB), (EG) and (GN) areas	4.2 kg
For (GC) area only	4.4 kg

Notes:

- Specifications are subject to change without notice. Weight and dimensions are approximate.
- Total harmonic distortion is measured by the digital spectrum analyzer.

System	Tuner/sound processor	Compact disc player	Amplifier	Cassette Deck	Speakers
SC-CH510	ST-CH510	SL-CH510	SE-CH510	RS-CH510	* SB-CH510A

*: For (E), (EG), (EB) areas Made in PAES
For (GC), (GN) areas Made in NABEL

■ Contents

	Page		Page
● Before Repair	2	● Operation Check and	
● Protection Circuitry	2	Main Component Replacement Procedures	12, 13
● Caution for AC Mains Lead	3	● Schematic Diagram	14~16
● Accessories	4	● Printed Circuit Board Diagram	17~19
● Stacking the Components	5	● Wiring Connection Diagram	20
● Connections	6~10	● Block Diagram	21
● Location of Controls	11	● Replacement Parts List	22~25
● Power Source ON/OFF of This Unit SE-CH510	11	● Cabinet Parts Location	26
		● Packaging	27, 28

■ Before Repair

- (1) Turn off the power supply. Using a 10 Ω , 10 W resistor, connect both ends of power supply capacitors (C701, C702) in order to discharge the voltage.
- (2) Before turning the power supply on, after completion of repair, slowly apply the primary voltage by using a power supply voltage controller to make sure that the consumed current at 50/60 Hz in NO SIGNAL mode should be shown below with respect to supply voltage 110 V/127 V/220 V/240 V.

Power supply voltage	AC 230 V	AC 240 V	AC 110~127 V	AC 220~240 V
Consumed current 50Hz	50~150 mA	50~150 mA	100~320 mA	50~160 mA

■ Protection Circuitry

The protection circuitry may have operated if either of the following conditions is noticed:

- * No sound is heard when the power is switched ON.
- * Sound stops during a performance.

The functions of this circuitry is to prevent circuitry damage if, for example, the positive and negative speaker connection wires are "shorted", or if speaker systems with an impedance less than the indicated rated impedance of this unit are used.

If this occurs, follow the procedure outlined below:

1. Switch OFF the power.
2. Determine the cause of the problem and correct it.
3. Switch ON the power once again.

Note:

When the protection circuitry functions, the unit will not operate unless the power is first switched OFF and then ON again.

For areas except (E) (EB) (EG) (GN)

CAUTION:

The AC voltage differs according to the area.

Be sure to set the proper voltage in your area before use.

Accessories

- AC power supply cord 1
for (E), (EG) and (GC) areas : (RJA0019-2A) for (EB) area : (VJA0733) for (GN) area : (RJA0036-K)

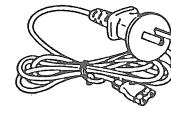
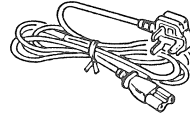
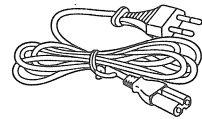

- Remote control transmitter (RAK-CH144WH) 1

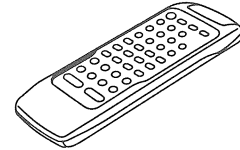

- Batteries (UM-4, "AAA", R03) 2
Note: These are available on sales route.

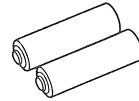

- Flat cable
Long (REX0511) 1
Short (REX0608) 1

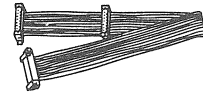

- AM (LW/MW) loop antenna (RSA0012) 1

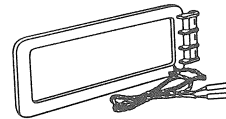

- Antenna holder (RMN0244) 1

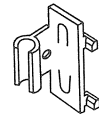

- Mounting screw (XTN3+12AFZ) 1



- FM indoor antenna (RSA0007) 1

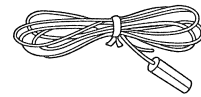

- Antenna plug (RFE0014) 1
for (GC) and (GN) areas

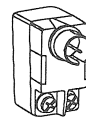

- Speaker cords (REE0499) 2

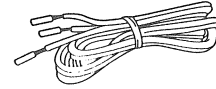
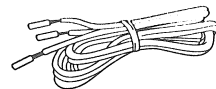

- Power plug adaptor (SJP5213-2) 1
for (GC) area only

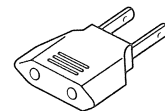

- Attachment plug for (EB) area (SJP9009) 1



Note:



The configurations of AC power supply cord and FM indoor antenna differ according to area.

Caution for AC Mains Lead

("EB" area code model only)

For your safety, please read the following text carefully.

This appliance is supplied with a moulded three pin mains plug for your safety and convenience. A 5-ampere fuse is fitted in this plug.

Should the fuse need to be replaced please ensure that the replacement fuse has a rating of 5-ampere and that it is approved by ASTA or BSI to BS1362. Check for the ASTA mark  or the BSI mark  on the body of the fuse.

If the plug contains a removable fuse cover you must ensure that it is refitted when the fuse is replaced. If you lose the fuse cover the plug must not be used until a replacement cover is obtained. A replacement fuse cover can be purchased from your local dealer.

CAUTION!

IF THE FITTED MOULDED PLUG IS UNSUITABLE FOR THE SOCKET OUTLET IN YOUR HOME THEN THE FUSE SHOULD BE REMOVED AND THE PLUG CUT OFF AND DISPOSED OF SAFELY. THERE IS A DANGER OF SEVERE ELECTRICAL SHOCK IF THE CUT OFF PLUG IS INSERTED INTO ANY 13-AMPERE SOCKET.

If a new plug is to be fitted please observe the wiring code as shown below.

If in any doubt please consult a qualified electrician.

IMPORTANT

The wires in this mains lead are coloured in accordance with the following code:

Blue: Neutral

Brown: Live

As the colours of the wires in the mains lead of this appliance may not correspond with the coloured markings identifying the terminals in your plug, proceed as follows:

The wire which is coloured BLUE must be connected to the terminal in the plug which is marked with the letter N or coloured BLACK.

This apparatus was produced to BS 800.

The wire which is coloured BROWN must be connected to the terminal in the plug which is marked with the letter L or coloured RED.

Under no circumstances should either of these wires be connected to the earth terminal of the three pin plug, marked with the letter E or the Earth Symbol .

Before use

Remove the connector cover as follows.

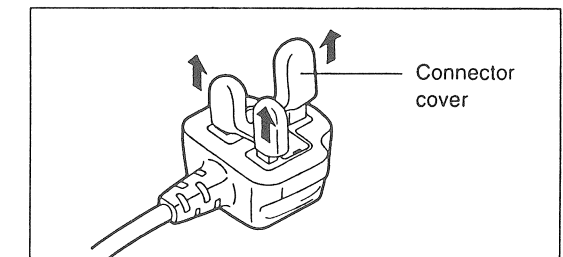

How to replace the fuse

1. Remove the fuse cover with a screwdriver.

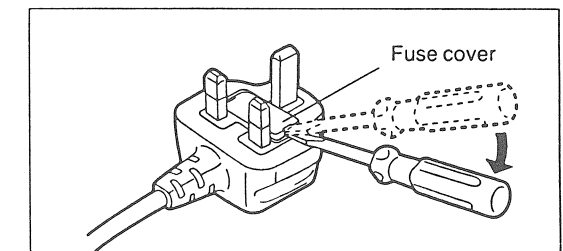

2. Replace the fuse and attach the fuse cover.

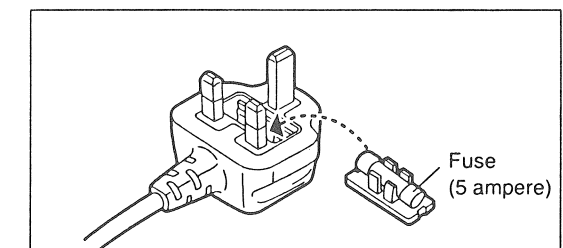

Stacking the Components

Install the various components as shown in the illustration.

Horizontal stacking **A**

Vertical stacking **B**

System layout example **C**

To produce a better stereo sound, install both speakers away from the system.

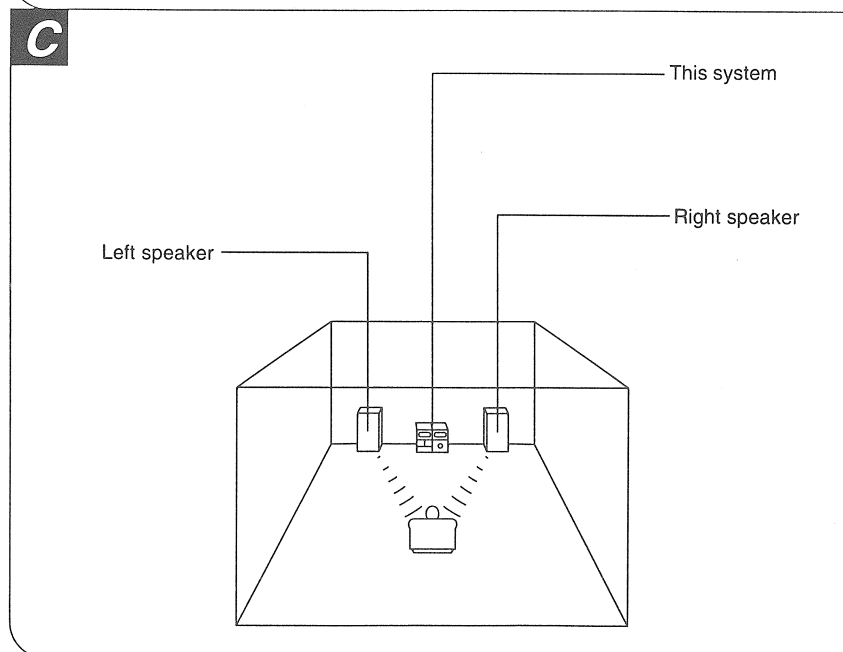
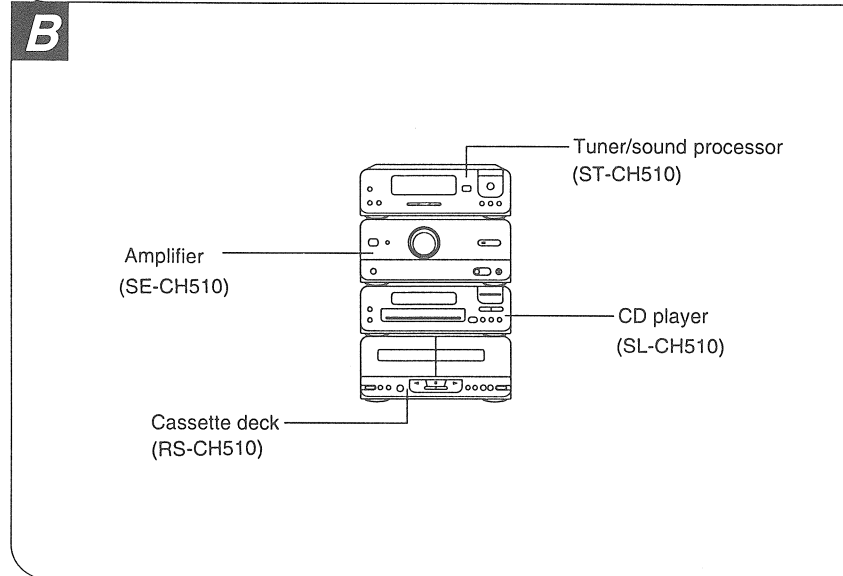
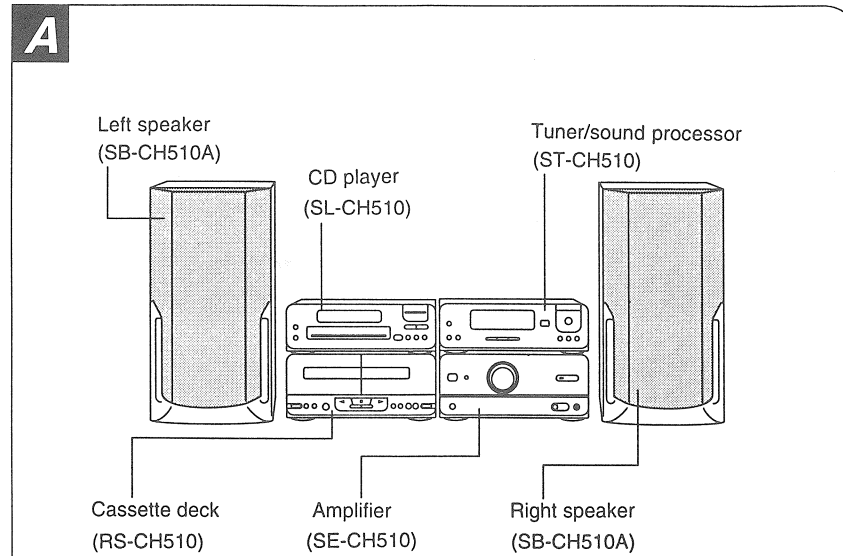

Connections

Connect the AC power supply cord after you have connected all other cables.

1 Connect the flat cables.

Hold the connector with the recessed part up and press in at the center until you hear a click.

1. Connect the shorter flat cable to the terminal of the tuner/sound processor and amplifier.
2. Connect the longer flat cable to the terminal of the tuner/sound processor, compact disc player, and cassette deck.

Be sure to connect the blue-colored connector to B1 (tuner/sound processor).

After connection, hold and press the cable as flat to the back of the unit as possible. (To minimize noise pickup while listening an AM broadcast)

Do not try connecting or disconnecting the flat cables while the power is switched to ON.

2 Connect the FM indoor antenna.

Install the antenna on a wall at a height and in a direction which result in the best reception.

The tip of the internal antenna wire should not come into contact with any metal objects.

When you cannot get a good reception with this FM indoor antenna, we recommend you install an FM outdoor antenna (not included).

(To be continued)

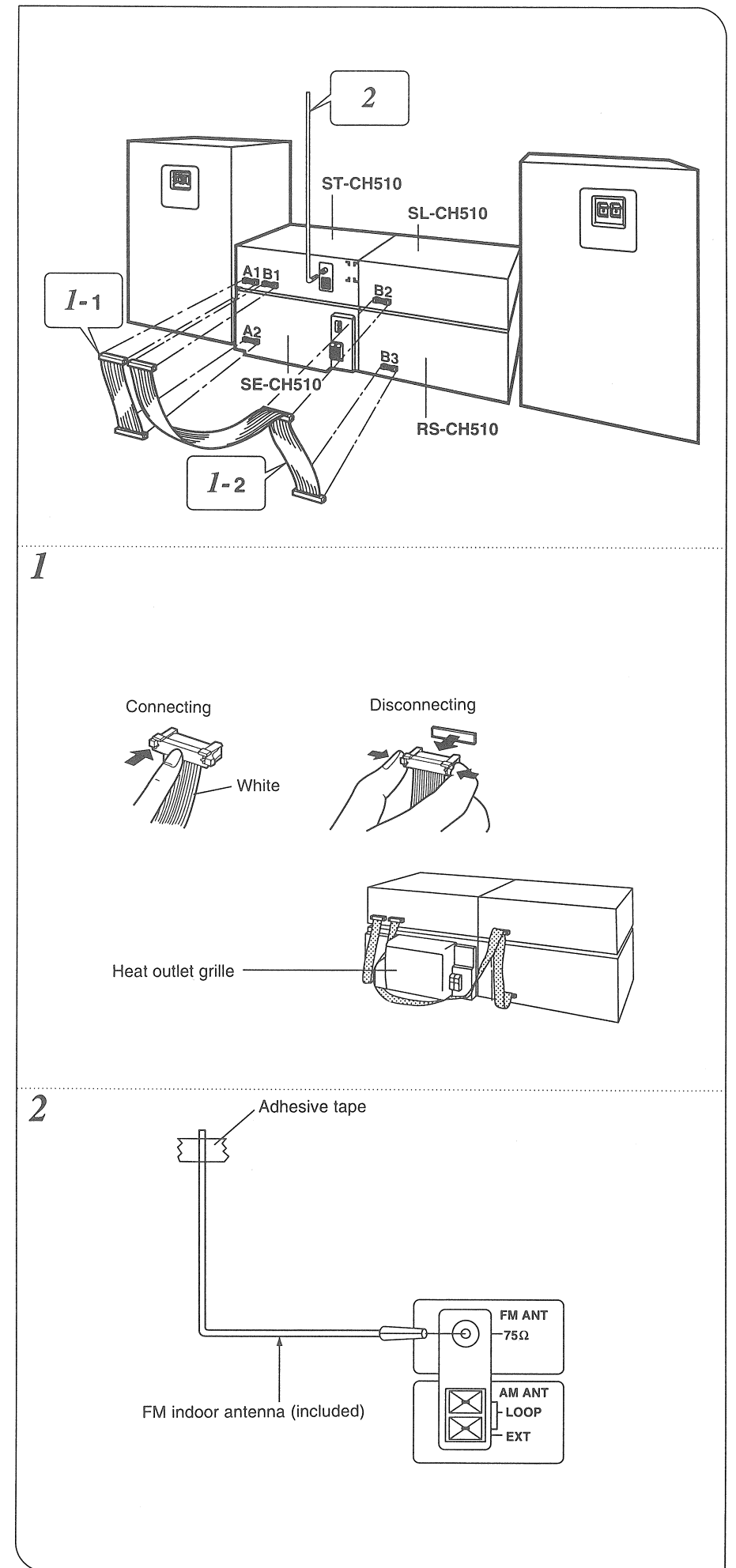

(Continued)

3 Connect the AM (MW/LW) loop antenna.

1. Attach the antenna holder to the rear panel of the tuner/sound processor. Press the antenna holder hard enough to get it fixed firmly in the place, with a click.
2. Clamp the antenna to the antenna holder.
3. Connect the antenna terminal to the rear panel of the tuner/sound processor.

- ① Strip off the outer covering.
- ② Twist the wire.
- ③ Insert the wire to the terminal of the tuner/sound processor.
- ④ Close the lever of the terminal.

(After you have connected all other cables)

4. While listening to a MW/LW broadcast, position the loop antenna for the best reception.

You may attach the antenna holder to a rack or other structure. Use a screw (included) to attach as showed in the figure. **A**

Note

To minimize noise pickup, keep the AM loop antenna cord away from the flat cables.

(To be continued)

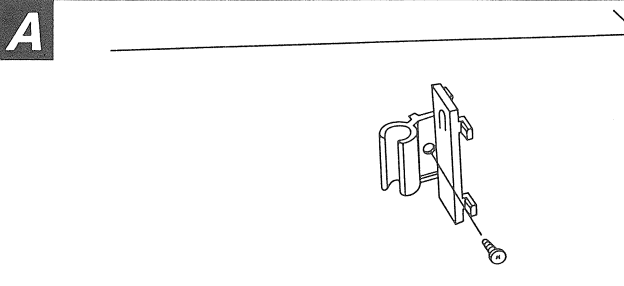
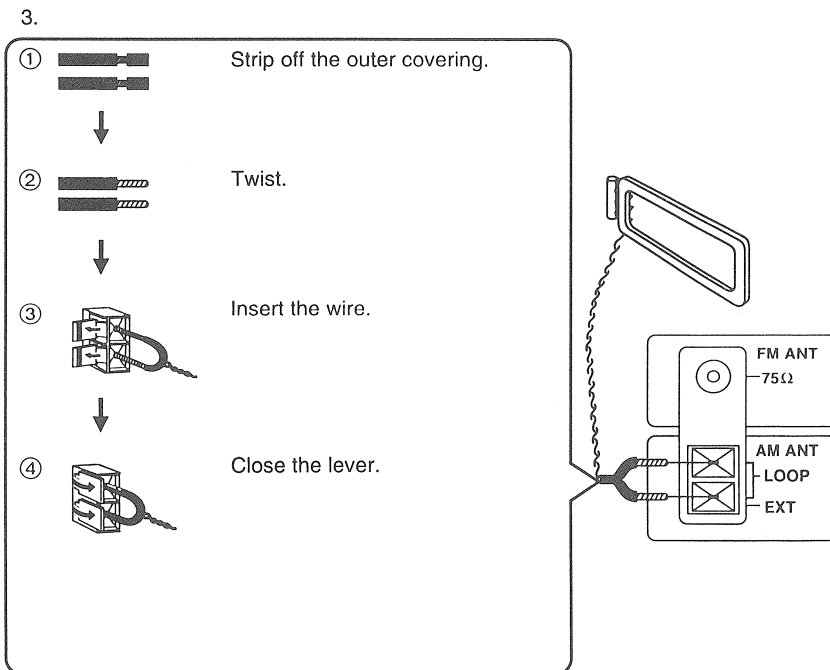
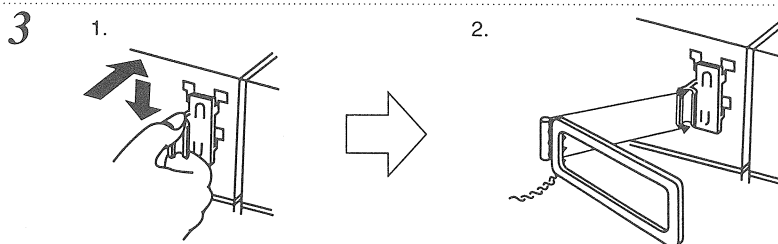
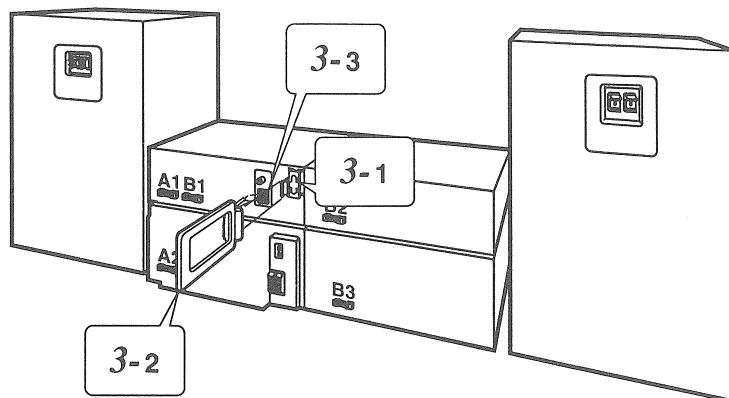

(Continued)

4 Connect the right (R) left (L) speaker cables.

Note

Be sure to connect speaker cables before connecting the AC power supply cord.

- The load impedance of any speaker used with this unit must be 6–8Ω.

Connection of speaker cables **A**

1. Strip off the outer covering, and twist the center conductor. Make sure the bare ends of the wires are not unraveled. (If they are, twist them tight again.)
2. ① Tilt the lever back and insert the wire.
② Close the lever and pull the cord gently to be sure that it is secured.
3. Insert the wire to the rear panel of the amplifier, and close the lever.

Notes

- To prevent damage to circuitry, never short-circuit positive (+) and negative (–) speaker wires.
- Be sure to connect only positive (+) wires to positive (+) terminals and negative (–) wires to negative (–) terminals.

5 Connect the AC power supply cord after you have connected all other cables and cords.

Insertion of connector **B**

Even when the connector is perfectly inserted, depending on the type of inlet used, the front part of the connector may jut out as shown in the drawing. However there is no problem using the unit.

For areas except for Continental Europe **C**

If the power plug will not fit your socket, use the power plug adaptor (included).

(To be continued)

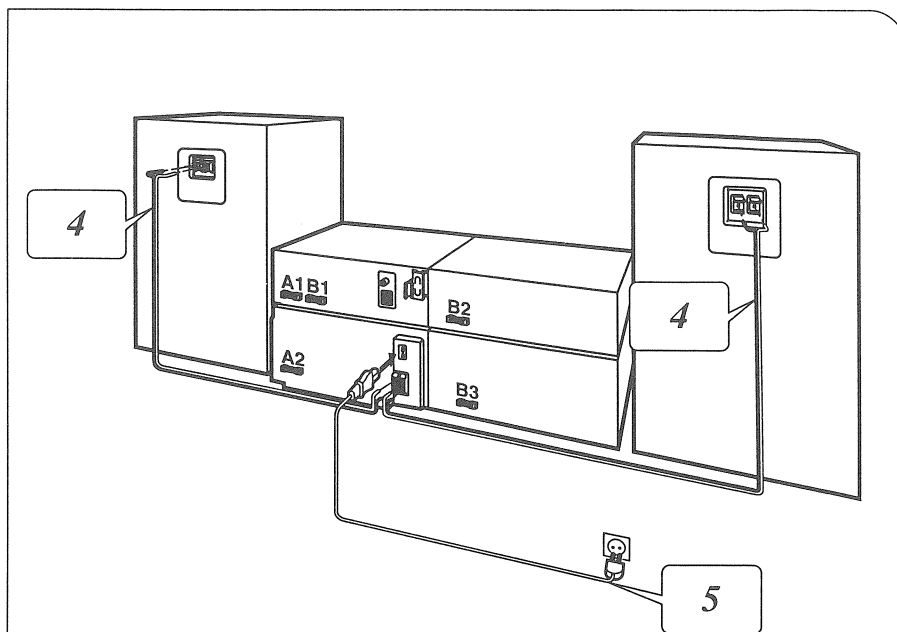

4

A

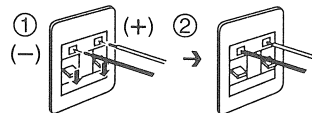
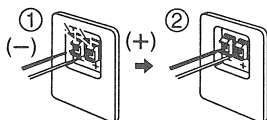
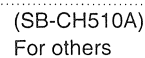
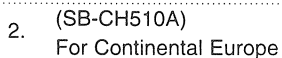
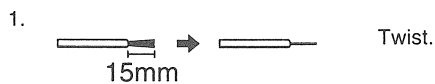

(SE-CH510)

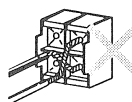
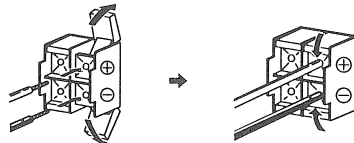

5

B

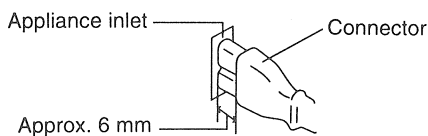

C

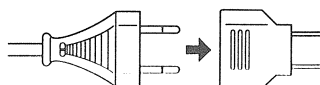

(Continued)

Optional antenna connections**FM outdoor antenna (not included)****A**

You may need an outdoor antenna if you use this system in a mountainous region or inside a reinforced-concrete building, etc. An outdoor antenna should be installed by a competent technician only.

AM (MW/LW) outdoor antenna (not included) B

An outdoor antenna may be required in a mountainous region, or if this system is located inside a reinforced-concrete building, etc.

Connect the outdoor antenna without removing the AM loop antenna. Run 5 to 12 m of vinyl-covered wire horizontally along a window or other convenient location.

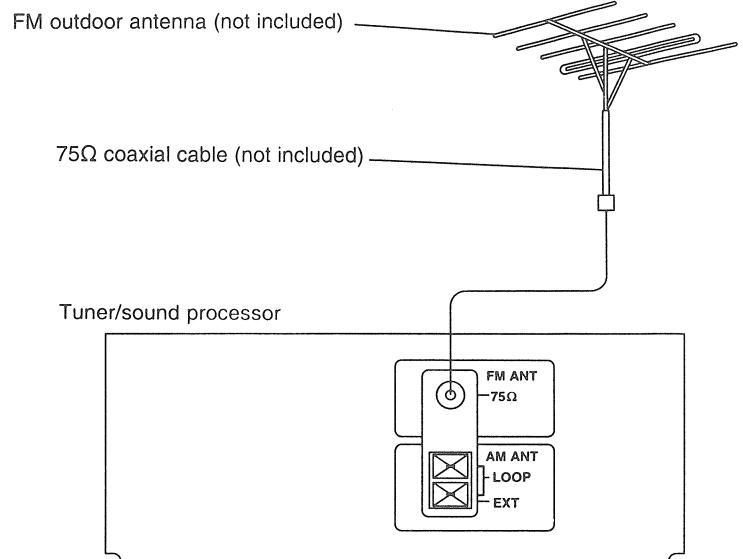
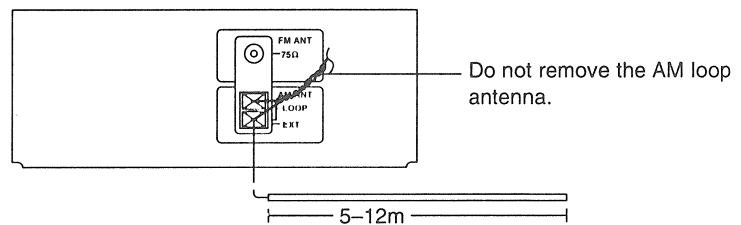
(To be continued)**A****B**

(Continued)

External unit connection

- For details, refer to the Operating Instructions of the units which are to be connected.
- When units other than those described below are to be connected, please consult with your audio dealer.

Connecting the stereo connection cable (not included) A

Connect the red plug to the right (R) connector.
Connect the white plug to the left (L) connector.

DCC (digital compact cassette deck) B

Analog player

This example shows how to connect the analog player with the PHONO OUT/LINE OUT switch.

For Continental Europe: C

"GND" terminal is for a ground wire use.
Set the PHONO OUT position at the back of the analog turntable.

For others: D

Only an analog turntable with a built-in phono equalizer can be connected.
Set the LINE OUT position at the back of the analog turntable.

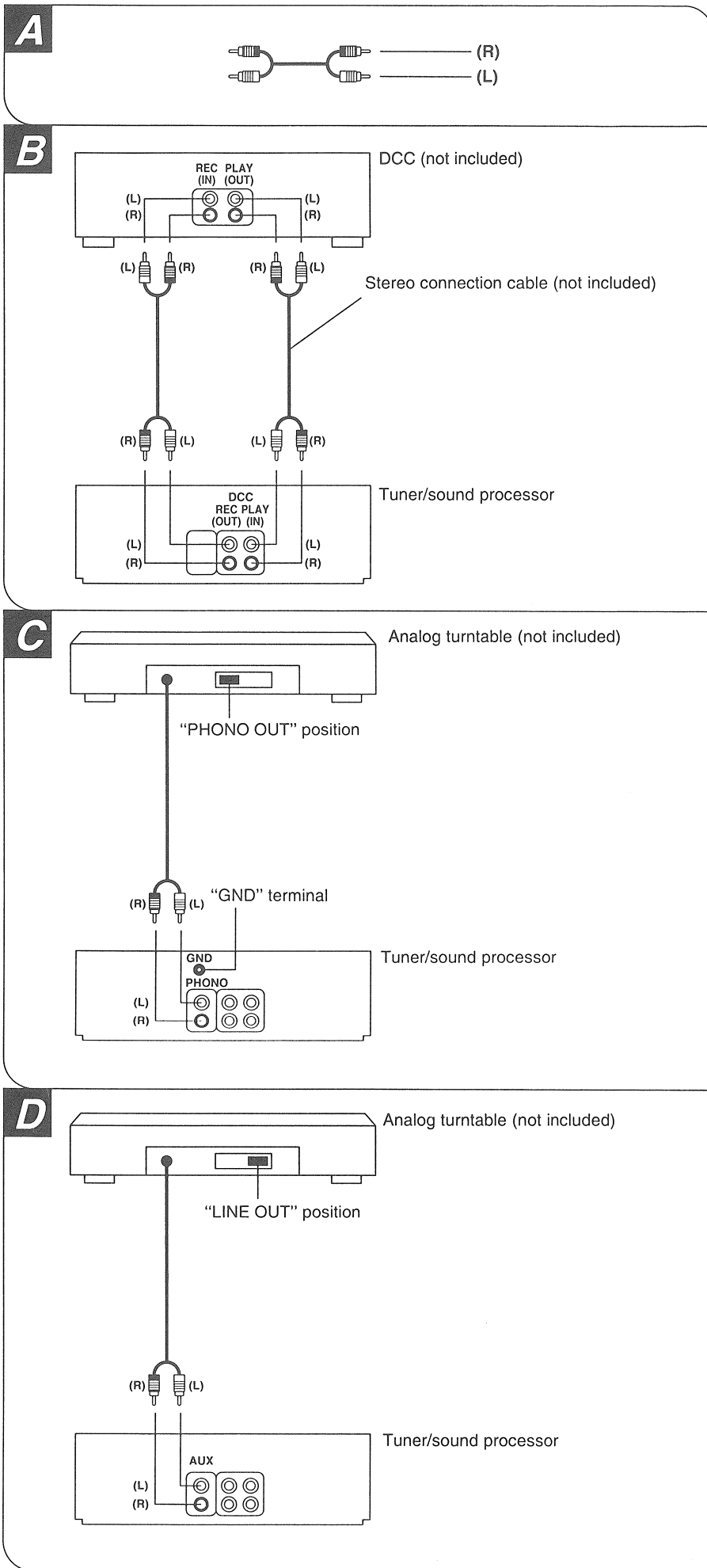

Location of Controls

- ① Power "STANDBY ON/OFF " switch (POWER, STANDBY ON/OFF)
Press to switch the unit from on to standby mode or vice versa. In standby mode, the unit is still consuming a small amount of power.
- ② Standby indicator (STANDBY)
When the unit is connected to the AC mains supply, this indicator lights up in standby mode and goes out when the unit is turned on.
- ③ Volume control
- ④ Power indicator
- ⑤ Headphones jack (ϕ 3.5, 32 Ω)
- ⑥ Microphone jack (ϕ 6.3, 600 Ω)
- ⑦ Microphone volume control

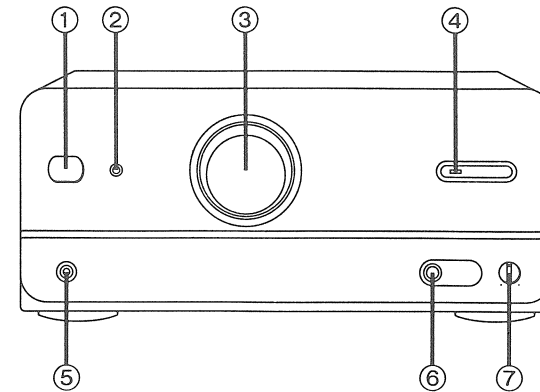

Power Source ON/OFF of This Unit SE-CH510

1. Connect the AC power cord of this unit to an AC outlet and turn it on.
(This unit comes to stand-by mode.)
2. Make test point TP701 (TP701) short as shown in Fig. 1.
POWER indicator lights and this unit comes to power ON mode.

Operation Check

1. Set this unit to power ON mode.
2. Input a signal (1 kHz, 100 mV) to the section between the resistor R611 (LINE IN for L-ch) and the capacitor C906 (LINE IN GND) as well as the section between the resistor R612 (LINE IN R-ch) and the capacitor C906 (LINE IN GND).
3. Connect the speaker to the speaker terminals and check if it sounds from the speaker.

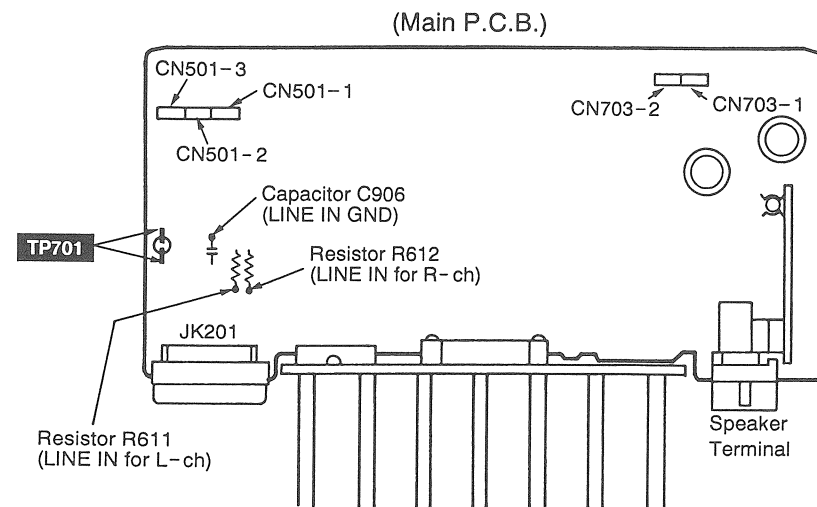

Fig. 1

Operation Check and Main Component Replacement Procedures

NOTE

1. This section describes procedures for checking the operation of the major printed circuit boards and replacing the main components.
2. For reassembly after operation checks or replacement, reverse the respective procedures. Special reassembly procedures are described only when required.
3. Select items from the following index when checks or replacement are required.
4. Illustrated screws are equivalent to actual size.
5. Refer the parts No. on the page of "Main Component Replacement Procedures", if necessary.

Contents

	Page
• Checking Procedure for each P.C.B.	
1. Checking for the operation P.C.B. and power transformer P.C.B.	12.
2. Checking for the main P.C.B.	13.
• Main Component Replacement Procedures	
1. Replacement for the power IC and regulator transistors	13.

Checking Procedure for each P.C.B.

1. Checking for the operation P.C.B. and power transformer P.C.B.

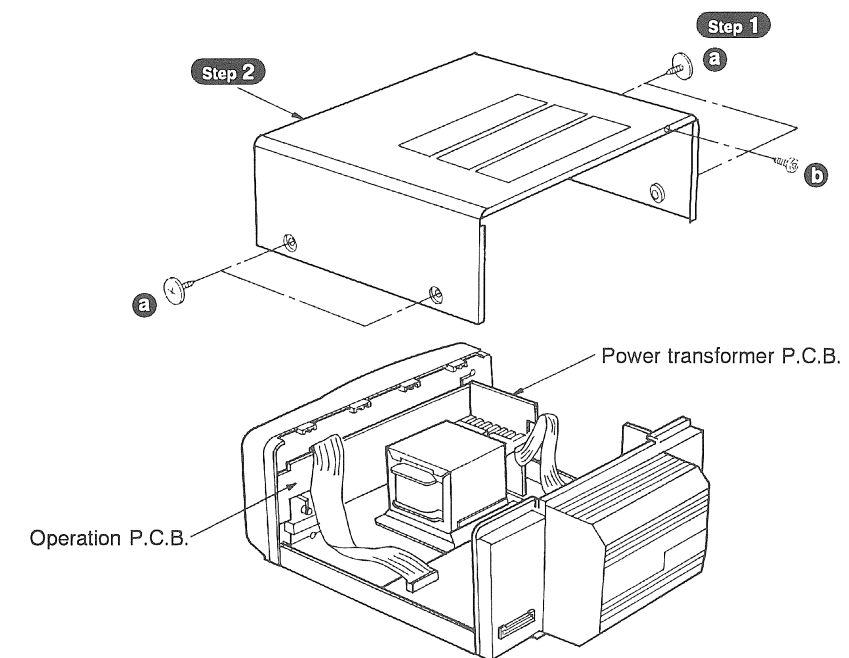

	a
	[RHD30007] (Black)
	b, c
	[XTBS3+8JFZ1] (Black)

Operation Check and Main Component Replacement Procedures

NOTE

1. This section describes procedures for checking the operation of the major printed circuit boards and replacing the main components.
2. For reassembly after operation checks or replacement, reverse the respective procedures. Special reassembly procedures are described only when required.
3. Select items from the following index when checks or replacement are required.
4. Illustrated screws are equivalent to actual size.
5. Refer the parts No. on the page of "Main Component Replacement Procedures", if necessary.

Contents

	Page
• Checking Procedure for each P.C.B.	
1. Checking for the operation P.C.B. and power transformer P.C.B.	12.
2. Checking for the main P.C.B.	13.
• Main Component Replacement Procedures	
1. Replacement for the power IC and regulator transistors	13.

Checking Procedure for each P.C.B.

1. Checking for the operation P.C.B. and power transformer P.C.B.

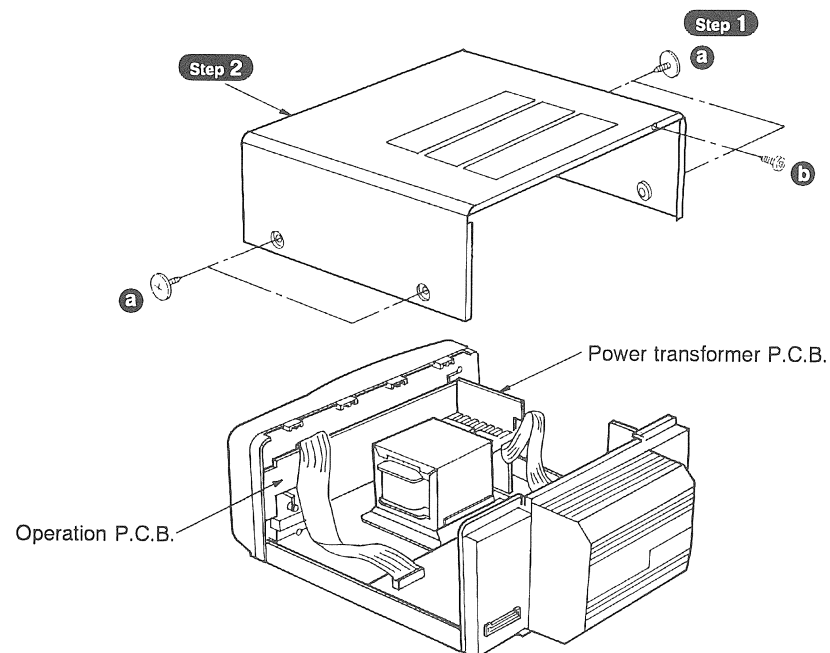

- a**
[RHD30007] (Black)
- b, c**
[XTBS3+8JFZ1] (Black)

2. Checking for the main P.C.B.

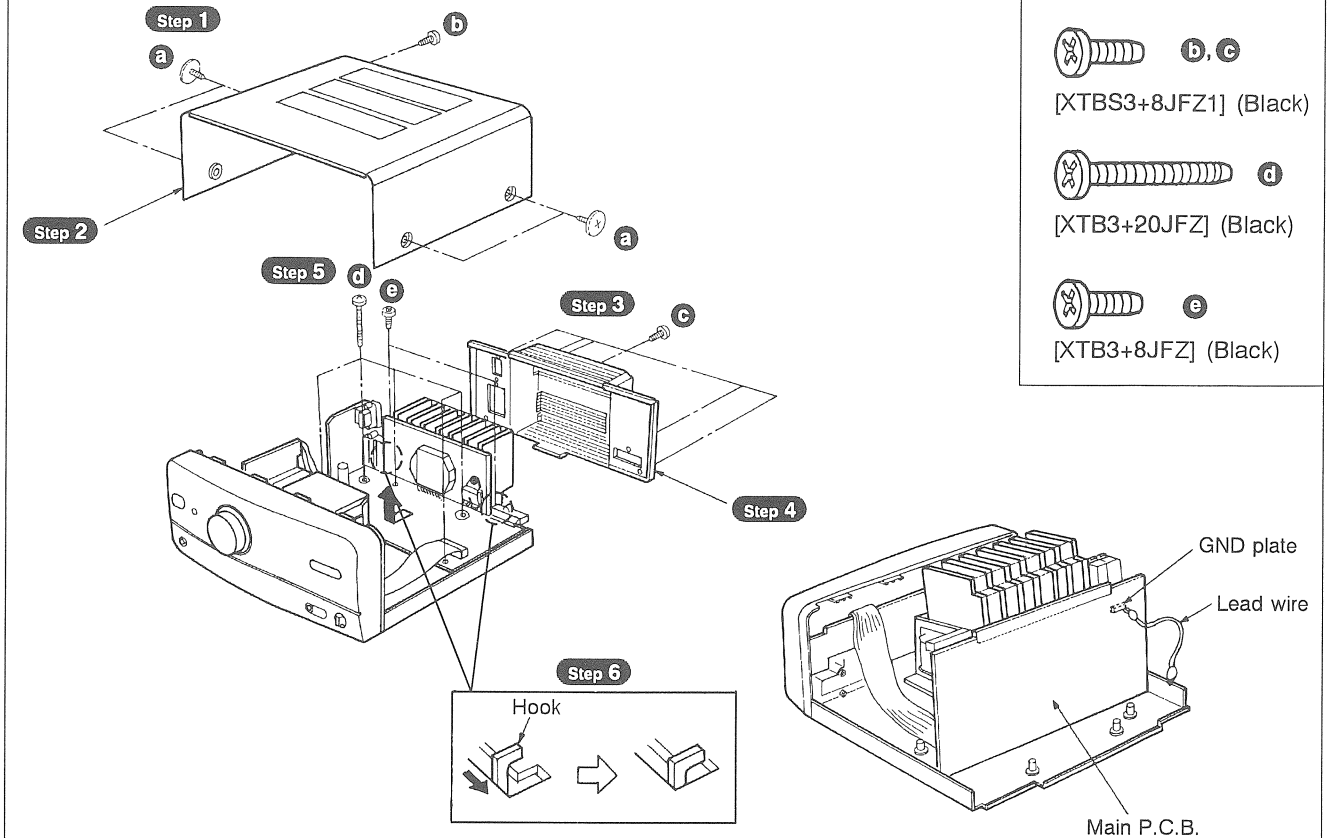

- a**
[RHD30007] (Black)
- b, c**
[XTBS3+8JFZ1] (Black)
- d**
[XTB3+20JFZ] (Black)
- e**
[XTB3+8JFZ] (Black)

Main Component Replacement Procedures

1. Replacement for the power IC and regulator transistors

- Follow the item 2 in checking procedure for each P.C.B. on this page.

NOTE

When mounting the power IC or regulator transistor, apply silicone compound (RFKX0002) to the rear side of power IC or regulator transistors.

- a**
[XTW3+15T]

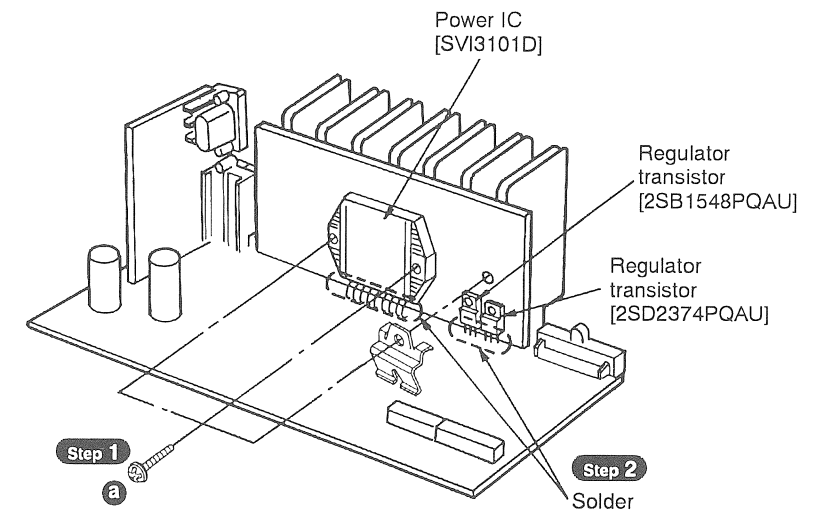

CN703-1

Speaker Terminal

Schematic Diagram (Parts list on Page 22~24)

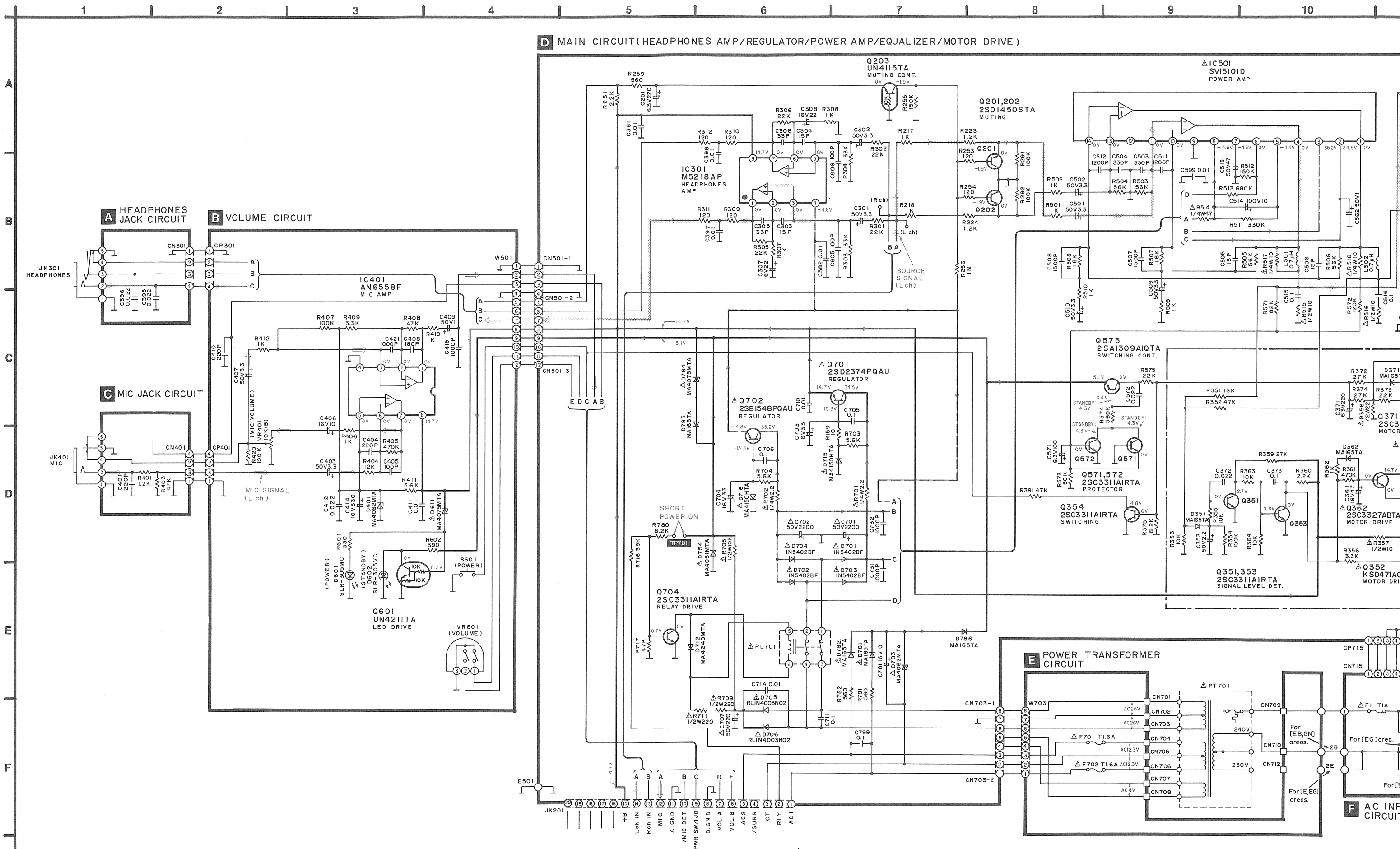

D MAIN CIRCUIT (HEADPHONES AMP/REGULATOR/POWER AMP/EQUALIZER/MOTOR DRIVE)

MAIN CIRCUIT (HEADPHONES AMP/REGULATOR/POWER AMP/EQUALIZER/MOTOR DRIVE)

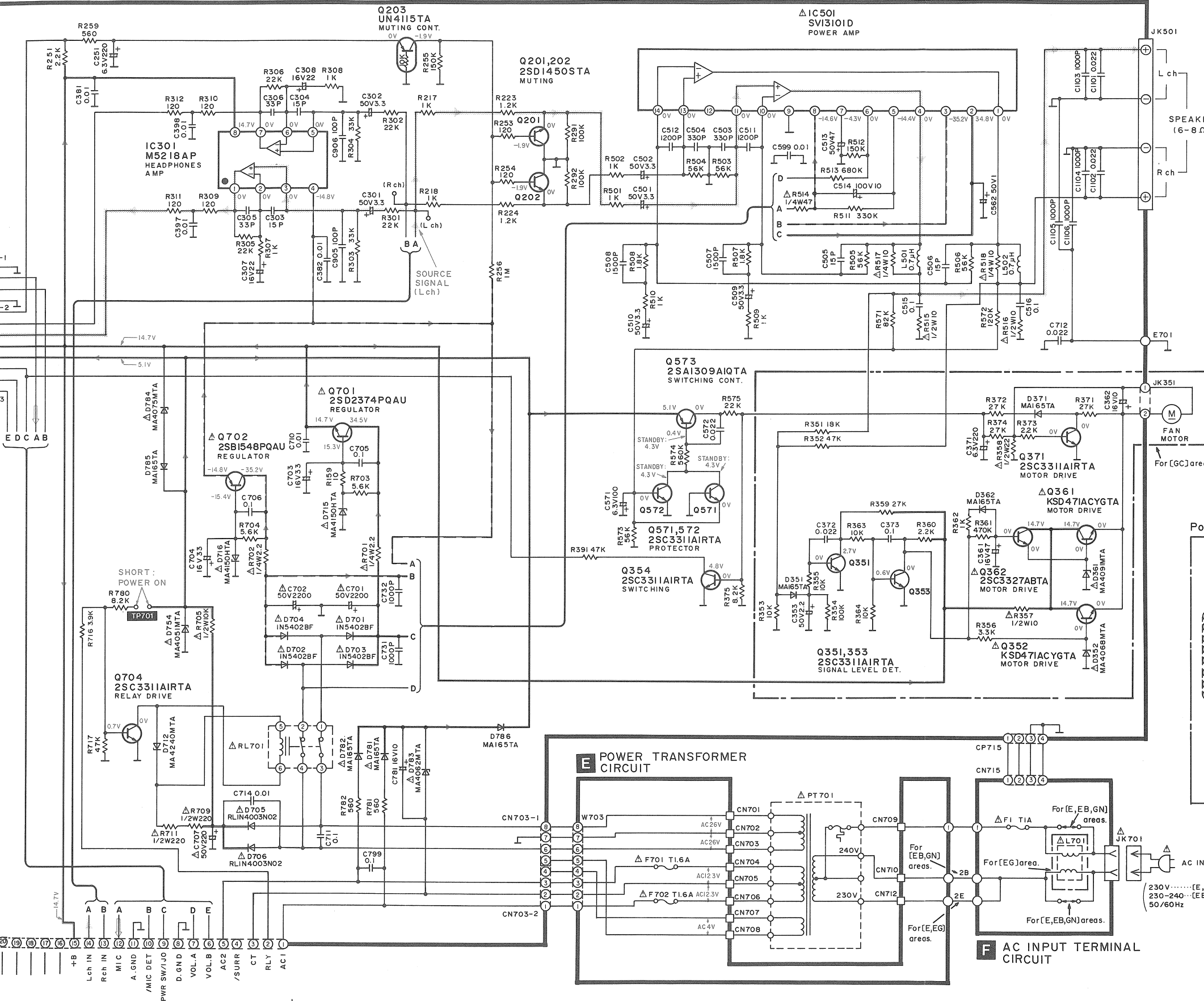

This schematic diagram may be modified at any time with the development of new technology.

Notes:

- S601 : Power switch (STANDBY \downarrow /ON)
- S701 : Voltage select switch in 220 V position. For (GC) area only.
- Indicated voltage values are the standard values for the unit measured by the DC electronic circuit tester (high-impedance) with the chassis taken as standard. Therefore, there may exist some errors in the voltage values, depending on the internal impedance of the DC circuit tester.

No mark : Power on

Important safety notice:

Components identified by Δ mark have special characteristics important for safety. Furthermore, special parts which have purposes of fire-retardant (resistors), high-quality sound (capacitors), low-noise (resistors), etc. are used. When replacing any of components, be sure to use only manufacturer's specified parts shown in the parts list.

Caution!

IC and LSI are sensitive to static electricity. Secondary trouble can be prevented by taking care during repair. Cover the parts boxes made of plastics with aluminum foil. Ground the soldering iron. Put a conductive mat on the work table. Do not touch the legs of IC or LSI with the fingers directly.

Voltage and signal line

- \longrightarrow : Positive voltage line
- \dashrightarrow : Negative voltage line
- \dashrightarrow : Source signal line (L-ch)
- \dashrightarrow : MIC signal

Power Source For [GC] area.

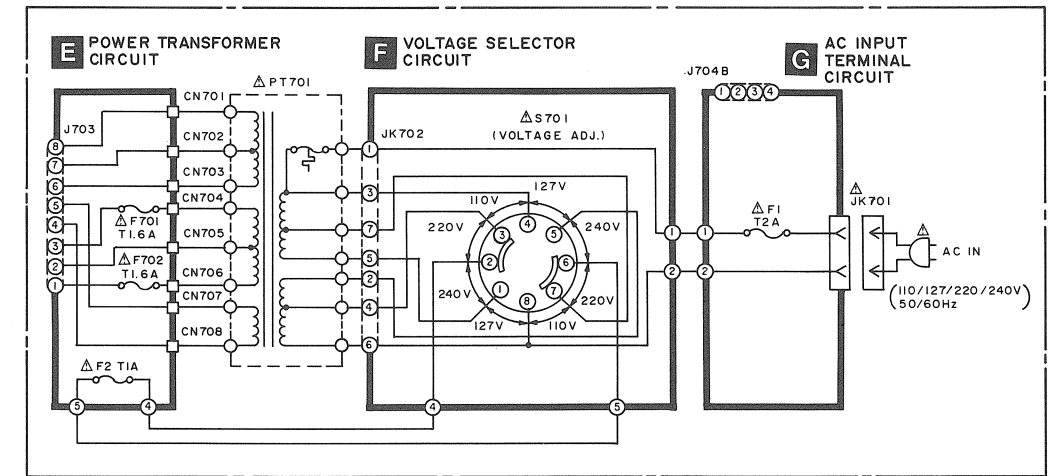

Printed Circuit Board Diagram

This circuit board diagram may be modified at any time with the development of new technology.

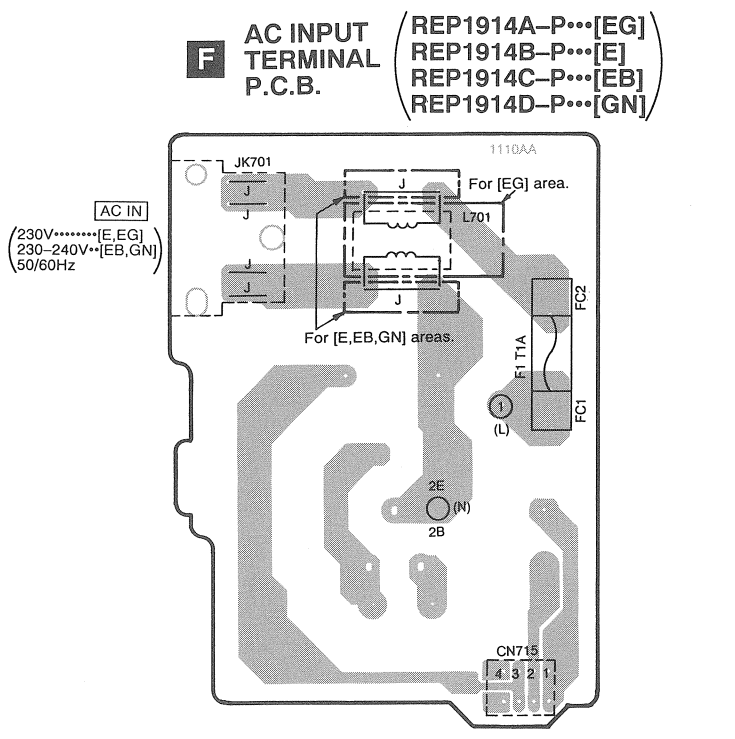
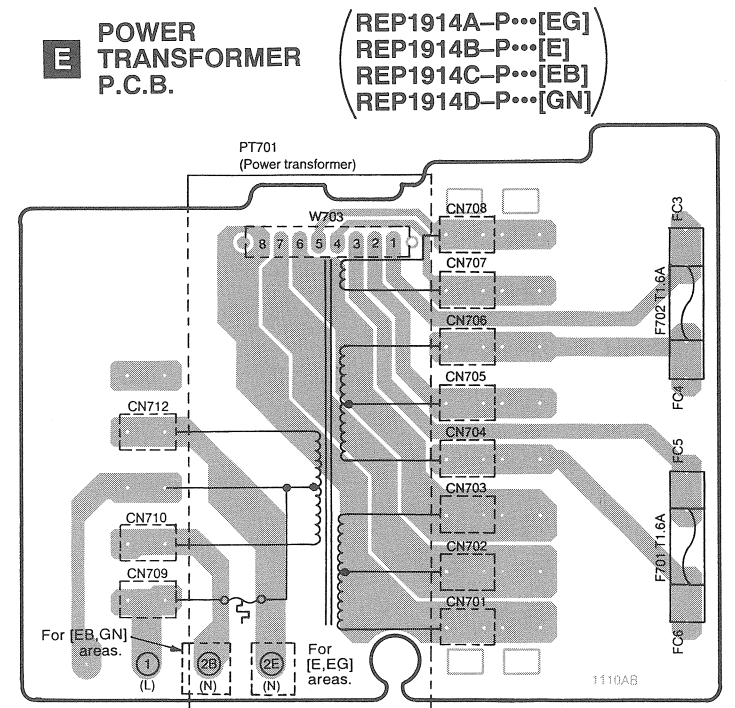
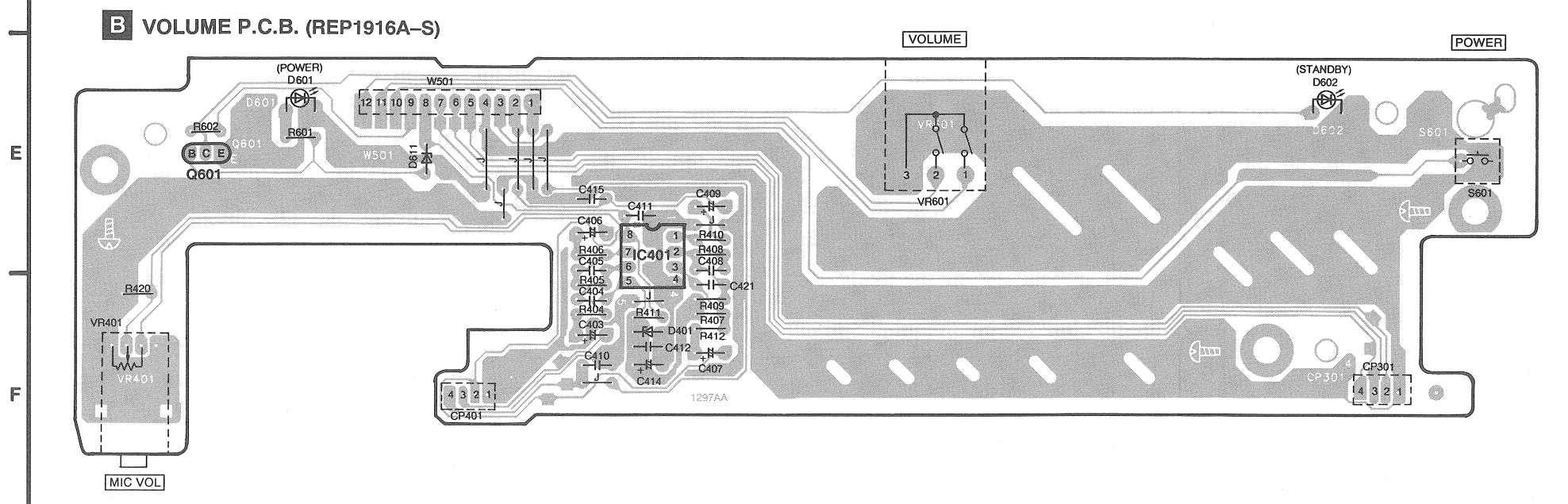
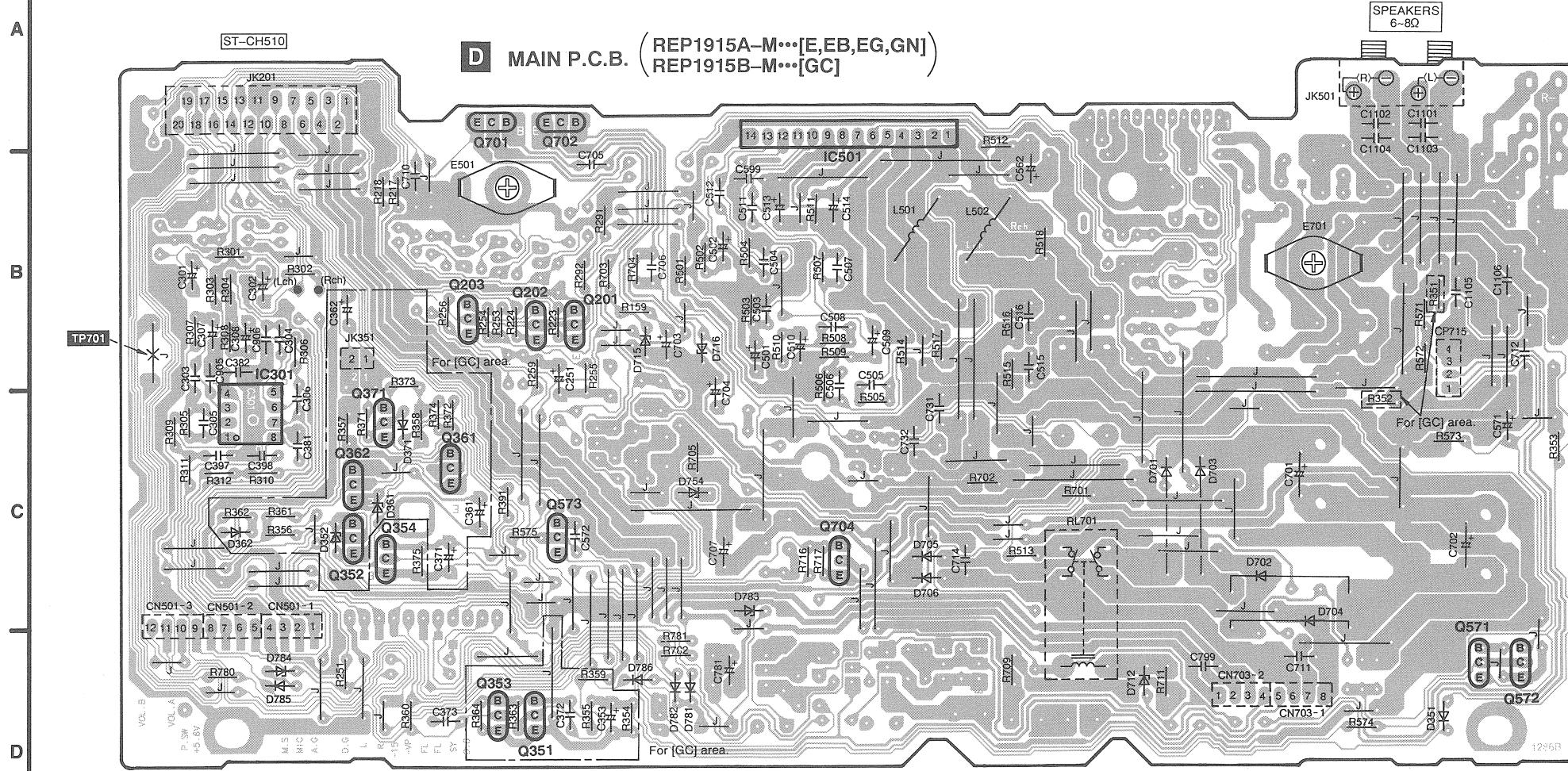

Wiring Connection Diagram

10 11 12 13 14

A HEADPHONES JACK P.C.B. (REP1916A-S)

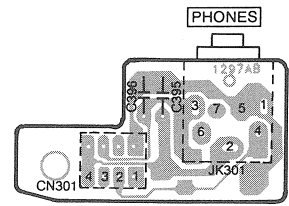

C MIC JACK P.C.B. (REP1916A-S)

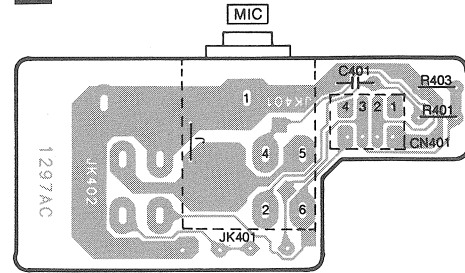

Power Source P.C.B. For [GC] area.

E POWER TRANSFORMER P.C.B. (REP1914E-P)

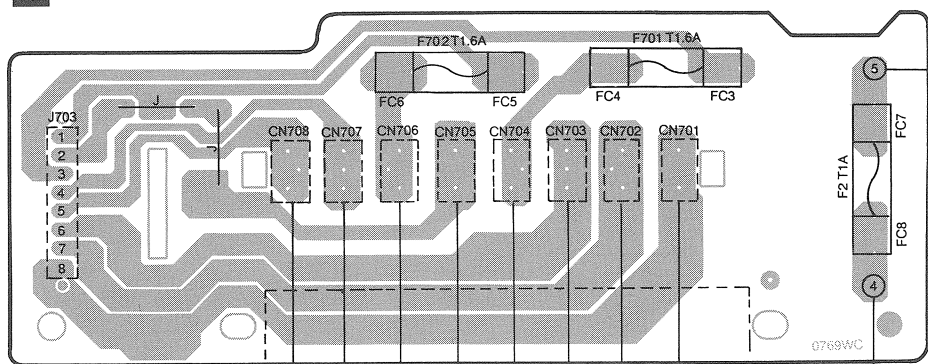

G AC INPUT TERMINAL P.C.B. (REP1914E-P)

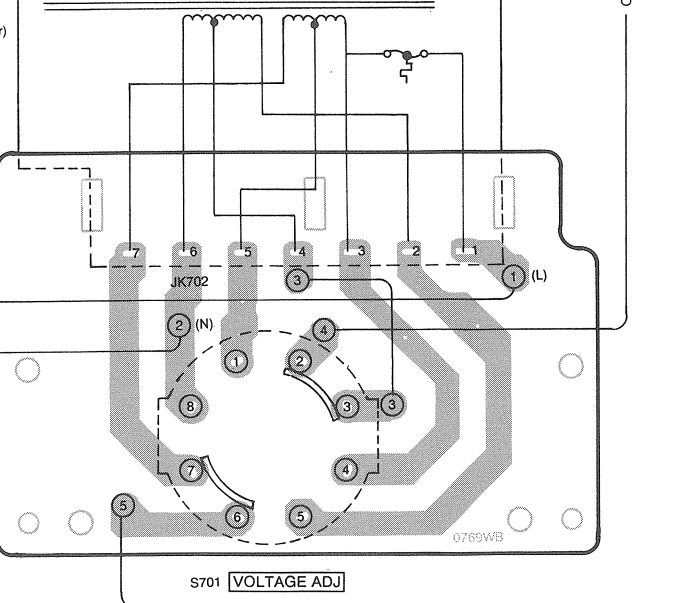
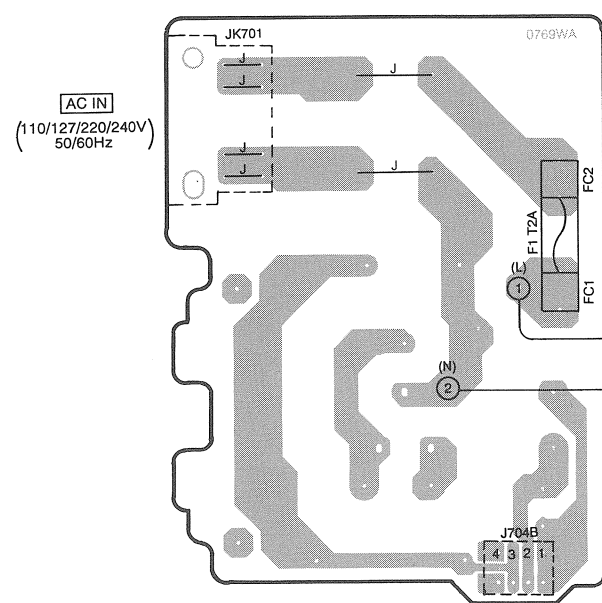

F VOLTAGE SELECTOR P.C.B. (REP1914E-P)

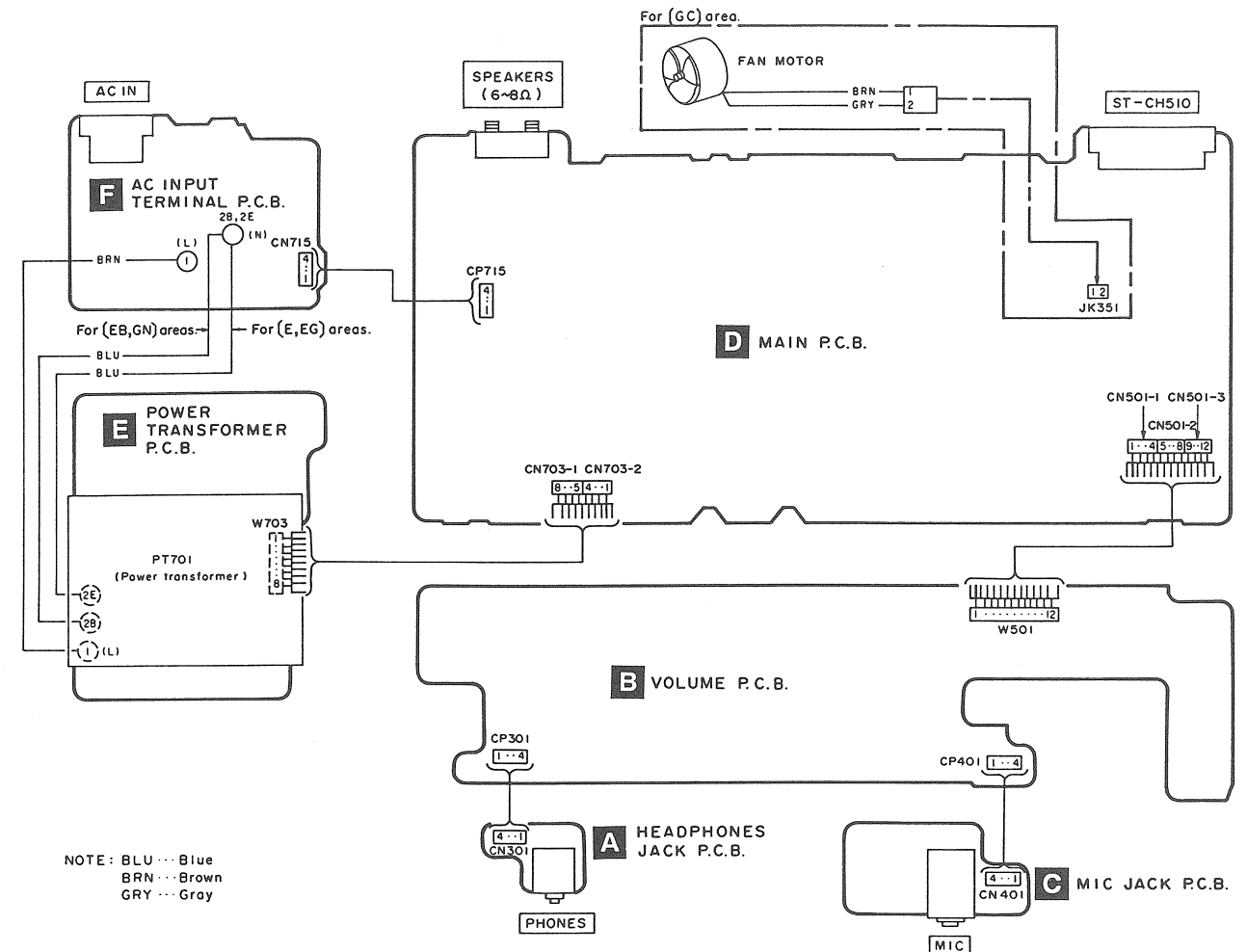

NOTE: BLU... Blue
BRN... Brown
GRY... Gray

Terminal Guide of IC's, Transistors and Diodes

<p>AN6558F</p>	<p>M5218AP</p>	<p>SVI3101D</p>	<p>2SB1548PQAU 2SD2374PQAU</p>	<p>2SC3327ABTA</p>
	<p>UN4115 UN4211 2SA1309AIQTA 2SC3311AIRTA 2SD1450RTA</p>	<p>KSD471ACYGTA</p>	<p>1N5402BF RL1N4003N02</p>	<p>MA4150M MA4240H</p>
	<p>MA4051MTA MA4062MTA MA4068M MA4075MTA MA4091MTA</p>	<p>SLR-305VC SLR-305MC</p>	<p>MA165TA</p>	

Block Diagram

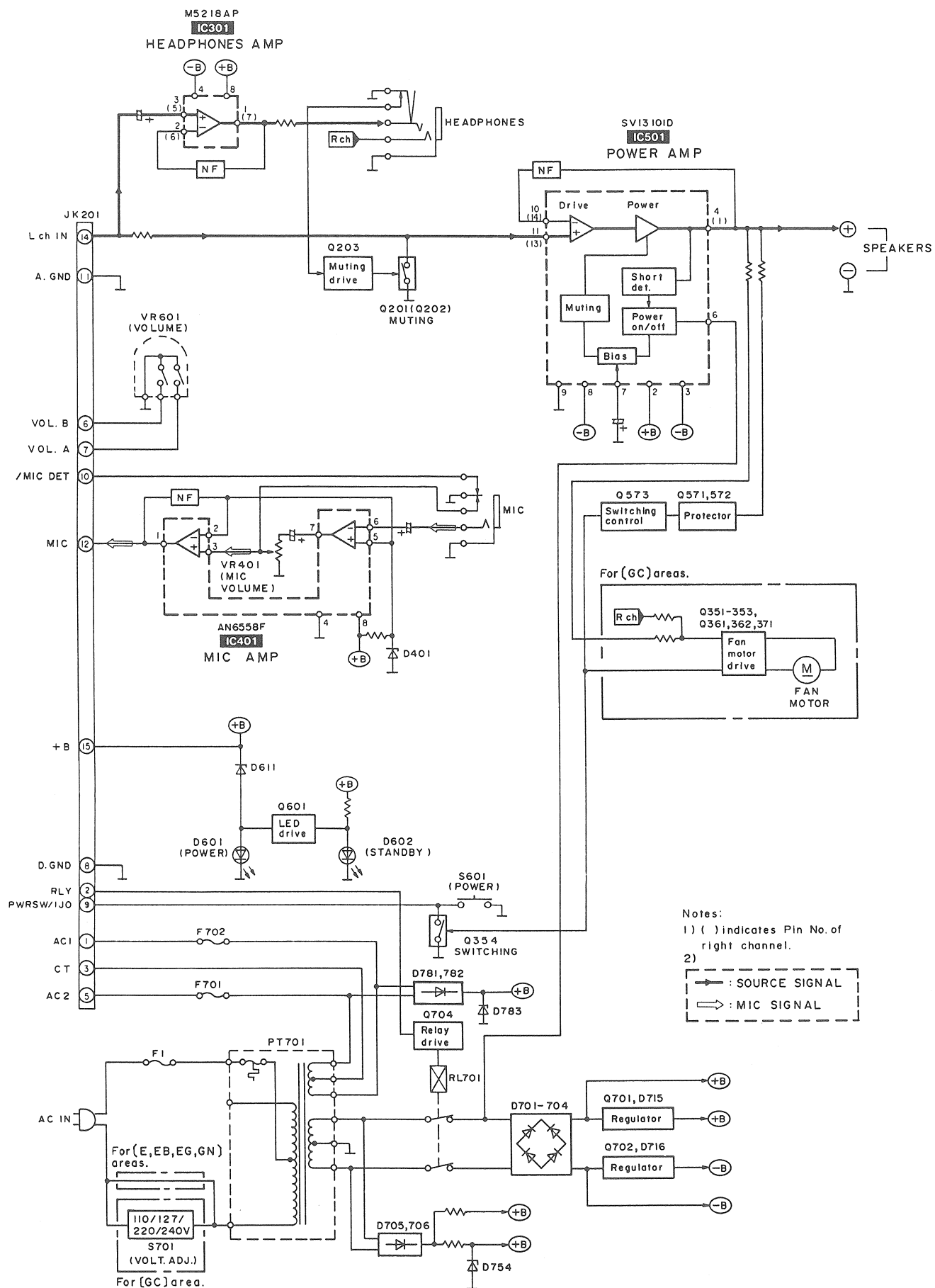

Replacement Parts List

Notes: *Important safety notice:
 Components identified by Δ mark have special characteristics important for safety.
 Furthermore, special parts which have purposes of fire-retardant (resistors), high-quality sound (capacitors), low-noise (resistors), etc. are used.
 When replacing any of components, be sure to use only manufacturer's specified parts shown in the parts list.
 *The parenthesized indications in the Remarks columns specify the areas. (Refer to the cover page for area.)
 Parts without these indications can be used for all areas.
 *Remote Control Ass'y: Supply period for three years from termination of production.
 *The "(SF)" mark denotes the standard part.

Ref. No.	Part No.	Part Name & Description	Remarks	Ref. No.	Part No.	Part Name & Description	Remarks
		INTEGRATED CIRCUIT(S)				VARIABLE RESISTOR(S)	
IC301	M5218AP	I. C. HEADPHONE AMP.		VR401	EYJ02BF01B14	V. R. MIC VOLUME CONTROL	
IC401	AN6558F	I. C. MIC AMP.		VR601	RRV16B24104B	V. R. MAIN VOLUME CONTROL	
IC501	SV13101D	I. C. POWER AMP.	Δ			COIL(S)	
		TRANSISTOR(S)					
Q201, 202	2SD1450RTA	TRANSISTOR		L501, 502	RLQYR73M	COIL	
Q203	UN4115	TRANSISTOR		L701	RLQZ271M	COIL	Δ (EG)
Q351	2SC3311AIRTA	TRANSISTOR	(GC)			FUSE(S)	
Q352	KSD471ACYGTA	TRANSISTOR	Δ (GC)	F1	XBA2C10TB0	FUSE, 250V T1. 0A	Δ (E, EB, EG, GN)
Q353	2SC3311AIRTA	TRANSISTOR	(GC)	F1	XBA2C20TB0	FUSE, 250V T2. 0A	Δ (GC)
Q354	2SC3311AIRTA	TRANSISTOR		F2	XBA2C10TB0	FUSE, 250V T1. 0A	Δ (GC)
Q361	KSD471ACYGTA	TRANSISTOR	Δ (GC)	F701, 702	XBA2C16TB0	FUSE, 250V T1. 6A	Δ
Q362	2SC3327ABTA	TRANSISTOR	Δ (GC)			SWITCH(ES)	
Q371	2SC3311AIRTA	TRANSISTOR	(GC)				
Q571, 572	2SC3311AIRTA	TRANSISTOR		S601	EVQ21405R	SW. POWER	
Q573	2SA1309AIQTA	TRANSISTOR		S701	ESE37263	SW. VOLTAGE ADJ.	Δ (GC)
Q601	UN4211	TRANSISTOR				CONNECTOR(S)	
Q701	2SD2374PQAU	TRANSISTOR	Δ	J704B	RJU057W004	SOCKET (4P)	(GC)
Q702	2SB1548PQAU	TRANSISTOR	Δ	CN301	RJU057W004	SOCKET (4P)	
Q704	2SC3311AIRTA	TRANSISTOR		CN401	RJU057W004	SOCKET (4P)	
		DIODE(S)		CN701-708	RJS1A1101T1	SOCKET (1P)	
D351	MA165TA	DIODE	(GC)	CN709, 710	RJS1A1101T1	SOCKET (1P)	(E, EB, EG, GN)
D352	MA4068MTA	DIODE	Δ (GC)	CN712	RJS1A1101T1	SOCKET (1P)	(E, EB, EG, GN)
D361	MA4091MTA	DIODE	Δ (GC)	CN715	RJU057W004	SOCKET (4P)	(E, EB, EG, GN)
D362	MA165TA	DIODE	(GC)	CN501-1-3	RJS1A6604	CONNECTOR (4P)	
D371	MA165TA	DIODE	(GC)	CN703-1, 2	RJS1A6604	CONNECTOR (4P)	
D372	MA165TA	DIODE	(GC)	CP301	RJT057W004-1	CONNECTOR (4P)	
D401	MA4062MTA	DIODE		CP401	RJT057W004-1	CONNECTOR (4P)	
D601	SLR-305MC	LED		CP715	RJT057W004-1	CONNECTOR (4P)	
D602	SLR-305VC	LED				EARTH TERMINAL(S)	
D611	MA4075MTA	DIODE	Δ				
D701-704	1N5402BF	DIODE	Δ	E501	SNE1004-1	GND PLATE	
D705, 706	RL1N4003N02	DIODE	Δ	E701	SNE1004-1	GND PLATE	
D712	MA4240H	DIODE				FUSE HOLDER(S)	
D715, 716	MA4150M	DIODE	Δ				
D754	MA4051MTA	DIODE	Δ				
D781, 782	MA165	DIODE	Δ				
D783	MA4062MTA	DIODE	Δ				
D784	MA4068M	DIODE	Δ				
D785, 786	MA165	DIODE		FC1-6	EYF52BC	FUSE HOLDER	

Ref. No.	Part No.	Part Name & Description	Remarks
FC7	EYP52BC	FUSE HOLDER	(GC)
FC8	EYP52BC	FUSE HOLDER	(GC)
		RELAY	
RL701	RSY0013M-0	RELAY	△
		TRANSFORMER (S)	
PT701	RTP2M5B002	POWER TRANSFORMER	△ (E, EB, EG, GN)
PT701	RTP2M5E002	POWER TRANSFORMER	△ (GC)
		JACK (S)	
JK201	RJT065K20	CONNECTOR (20P)	
JK301	RJJ37TN01-C	HEADPHONES JACK	
JK351	SJT3213	CONNECTOR (2P)	(GC)
JK401	RJJ65MA01	MIC JACK	
JK501	RJR0054M	SPEAKER TERMINAL	
JK701	SJS9236	AC INLET	△ (E, EB, EG, GC)
JK701	SJSD16	AC INLET	△ (GN)
JK702	SJS702-1	CONNECTOR (6P)	(GC)

Notes : * Capacity values are in microfarads (uF) unless specified otherwise, P=Pico-farads (pF) F=Farads (F)
* Resistance values are in ohms, unless specified otherwise, 1K=1,000 (OHM) , 1M=1,000k (OHM)

Ref. No.	Part No.	Values & Remarks	Ref. No.	Part No.	Values & Remarks	Ref. No.	Part No.	Values & Remarks
		RESISTORS	R501, 502	ERDS2TJ102	1/4W 1K	C408	ECBT1H181KB5	50V 180P
			R503-506	ERDS2TJ563	1/4W 56K	C409	ECEA1HKA010B	50V 1U
			R507, 508	ERDS2TJ182	1/4W 1.8K	C410	ECBT1H221KB5	50V 220P
R159	ERDS2TJ100	1/4W 10	R509, 510	ERDS2TJ102	1/4W 1K	C411	ECBT1E103ZF	25V 0.01U
R217, 218	ERDS2TJ102	1/4W 1K	R511	ERDS2TJ334	1/4W 330K	C412	ECBT1E223ZF	25V 0.022U
R223, 224	ERDS2TJ122	1/4W 1.2K	R512	ERDS2TJ154	1/4W 150K	C414	ECA1AM331B	10V 330U
R251	ERDS2TJ222	1/4W 2.2K	R513	ERDS2TJ684	1/4W 680K	C415	ECBT1H102KB5	50V 1000P
R253, 254	ERDS2EJ121	1/4W 120	R514	ERD25FJ470	1/4W 47 △	C421	ECBT1H102KB5	50V 1000P
R255	ERDS2TJ154	1/4W 150K	R515, 516	ERDS1FVJ100T	1/2W 10 △	C501, 502	ECA1HAP3R3B	50V 3.3U
R256	ERDS2TJ105T	1/4W 1M	R517, 518	ERD25FVJ100T	1/4W 10 △	C503, 504	ECBT1H331KB5	50V 330P
R259	ERDS2TJ561	1/4W 560	R571	ERDS2TJ823T	1/4W 82K	C505, 506	ECBT1H150J5	50V 15P
R291, 292	ERDS2TJ104	1/4W 100K	R572	ERDS2TJ124T	1/4W 120K	C507, 508	ECBT1C152KR5	16V 1500P
R301, 302	ERDS2TJ223	1/4W 22K	R573	ERDS2TJ563	1/4W 56K	C509, 510	ECEA1HKA3R3B	50V 3.3U
R303, 304	ERDS2TJ333	1/4W 33K	R574	ERDS2TJ564	1/4W 560K	C511, 512	ECBT1C122KR5	16V 1200P
R305, 306	ERDS2TJ223	1/4W 22K	R575	ERDS2TJ223	1/4W 22K	C513	ECA1HM470B	50V 47U
R307, 308	ERDS2TJ102	1/4W 1K	R601	ERDS2TJ331	1/4W 330	C514	ECA2AAP100B	100V 10U
R309-312	ERDS2EJ121	1/4W 120	R602	ERDS2TJ391	1/4W 390	C515, 516	ECBT1H104ZF5	50V 0.1U
R351	ERDS2TJ183T	1/4W 18K (GC)	R701, 702	ERD25FJ2R2	1/4W 2.2 △	C562	ECEA1HKN010B	50V 1U
R352	ERDS2TJ473T	1/4W 47K (GC)	R703, 704	ERDS2TJ562	1/4W 5.6K	C571	ECEA0JKA101B	6.3V 100U
R353	ERDS2TJ103T	1/4W 10K (GC)	R705	ERDS1FVJ103T	1/2W 10K △	C572	ECBT1E223ZF	25V 0.022U
R354	ERDS2TJ104T	1/4W 100K (GC)	R709	ERDS1FVJ221T	1/2W 220 △	C599	ECBT1C103MS5	16V 0.01U
R355	ERDS2TJ103T	1/4W 10K (GC)	R711	ERDS1FVJ221T	1/2W 220 △	C701, 702	ECA1HM222B	50V 2200U △
R356	ERDS2TJ332T	1/4W 3.3K (GC)	R716	ERDS2TJ392T	1/4W 3.9K	C703, 704	ECEA1CKA330B	16V 33U
R357	ERDS1FVJ100T	1/2W 10 △ (GC)	R717	ERDS2TJ473	1/4W 47K	C705, 706	ECBT1H104ZF5	50V 0.1U
R358	ERDS1FVJ220T	1/2W 22 △ (GC)	R780	ERDS2TJ822	1/4W 8.2K	C707	RCE1HM221BV	50V 220U △
R359	ERDS2TJ273T	1/4W 27K (GC)	R781, 782	ERDS2TJ561	1/4W 560	C710	ECBT1E103ZF	25V 0.01U
R360	ERDS2TJ222T	1/4W 2.2K (GC)				C711	ECQE1104KF3	100V 0.1U
R361	ERDS2TJ474T	1/4W 470K (GC)			CAPACITORS	C712	ECBT1E223ZF	25V 0.022U
R362	ERDS2TJ102T	1/4W 1K (GC)	C251	RCE0JKA221BV	6.3V 220U	C714	ECKR1H103ZF5	50V 0.01U
R363	ERDS2TJ103T	1/4W 10K (GC)	C301, 302	ECEA1HKA3R3B	50V 3.3U	C731, 732	ECKT1H102KB	50V 1000P
R364	ERDS2TJ103T	1/4W 10K (GC)	C303, 304	ECBT1H150J5	50V 15P	C781	ECEA1CKA100B	16V 10U
R371	ERDS2TJ273T	1/4W 27K (GC)	C305, 306	ECBT1H330J5	50V 33P	C799	ECBT1H104ZF5	50V 0.1U
R372	ERDS2TJ273T	1/4W 27K (GC)	C307, 308	ECEA1CKA220B	16V 22U	C905, 906	ECBT1H101KB5	50V 100P
R373	ERDS2TJ222T	1/4W 2.2K (GC)	C353	ECEA1HKA2R2B	50V 2.2U (GC)	C1101, 1102	ECBT1E223ZF	25V 0.022U
R374	ERDS2TJ273T	1/4W 27K (GC)	C361	ECEA1CKA470B	16V 47U (GC)	C1103-1106	ECBT1H102KB5	50V 1000P
R375	ERDS2TJ822	1/4W 8.2K	C362	ECEA1CKA100B	16V 10U (GC)			
R391	ERDS2TJ473	1/4W 47K	C371	RCE0JKA221BV	6.3V 220U (GC)			
R401	ERDS2TJ122	1/4W 1.2K	C372	ECBT1E223ZF5	25V 0.022U (GC)			
R403	ERDS2TJ473	1/4W 47K	C373	ECBT1H104ZF5	50V 0.1U (GC)			
R404	ERDS2TJ123	1/4W 12K	C381, 382	ECBT1E103ZF	25V 0.01U			
R405	ERDS2TJ474	1/4W 470K	C395, 396	ECBT1E223ZF	25V 0.022U			
R406	ERDS2TJ102	1/4W 1K	C397, 398	ECBT1E103ZF	25V 0.01U			
R407	ERDS2TJ104	1/4W 100K	C401	ECBT1H221KB5	50V 220P			
R408	ERDS2TJ473	1/4W 47K	C403	ECEA1HKA3R3B	50V 3.3U			
R409	ERDS2TJ332	1/4W 3.3K	C404	ECBT1H221KB5	50V 220P			
R410	ERDS2TJ102	1/4W 1K	C405	ECBT1H101KB5	50V 100P			
R411	ERDS2TJ562	1/4W 5.6K	C406	ECEA1CKA100B	16V 10U			
R412	ERDS2TJ102	1/4W 1K	C407	ECEA1HKA3R3B	50V 3.3U			
R420	ERDS2TJ104	1/4W 100K						

Ref. No.	Part No.	Part Name & Description	Remarks	Ref. No.	Part No.	Part Name & Description	Remarks
		CABINET PARTS LIST		P3	RPG2232	PACKING CASE (CD-TUNER)	
				P4	RPG2230	PACKING CASE (AMPLIFIER)	
				P5	RPN0815	PAD (DECK)	
1	RKMD265A-K	CABINET		P6	RPN0816	PAD (CD-TUNER)	
2	RGW0207-K	KNOB, MAIN VOLUME		P7	RPN0817	PAD (AMPLIFIER)	
3	RFKJE1060EK	BOTTOM BOARD ASS'Y	(E, EB, EG, GN)	P8	SPP740	PROTECTION COVER	
3	RFKJE1060GCK	BOTTOM BOARD ASS'Y	(GC)	P9	RPQF0047	ACCESSORIES BOX	
3-1	RKA0011-3	FOOT		P10	RPQ0458	SPACER	
4	RFKHECH510EB	REAR PANEL ASS'Y	(EB, GN)	P11	XZB25X34C03Y	PROTECTION COVER	
4	RFKHECH510EG	REAR PANEL ASS'Y	(EG)			ACCESSORIES	
4	RFKHECH510GC	REAR PANEL ASS'Y	(GC)				
4	RKFO376C-K	REAR GRILL ASS'Y	(E)	A1	RAK-CH144WH	REMOTE CONTROL TRANSMITTER	
5	RKQ0089	P. C. B. SPACER		A1-1	RKK0057-K	BATTERY COVER	
6	RMCO158	TRANSISTOR HOLDER		A2	REE0499	SPEAKER CORD	
7	RMNO277	HOLDER		A3	REX0511	FLAT CABLE (LONG TYPE)	
8	RFKGECH510EK	FRONT PANEL ASS'Y		A4	REX0608	FLAT CABLE (SHORT TYPE)	
9	RFKNECH510EA	PANEL LIGHT A		A5	RJA0019-2A	AC POWER SUPPLY CORD	△ (E, EG, GC) (SF)
10	RGU1077-K	BUTTON, POWER		A5	VJA0733	AC POWER SUPPLY CORD	△ (EB) (SF)
11	RFKNECH510EB	PANEL LIGHT B		A5	RJA0036-K	AC POWER SUPPLY CORD	△ (GN)
12	RGW0178-1K	KNOB, MIC VOLUME		A6	RFKSECH510EK	INSTRUCTION MANUAL	(E)
13	RWJ1808130XX	FLAT CABLE (8P) (W703)	(E, EB, EG, GN)	A6	RFKSECH510EB	INSTRUCTION MANUAL	(EB)
13	RWJ1808100XX	FLAT CABLE (8P) (J703)	(GC)	A6	RQT2591-E	INSTRUCTION MANUAL	(EG)
14	RWJ1812220QC	FLAT CABLE (12P) (W501)		A6	RQT2590-G	INSTRUCTION MANUAL	(GC)
18	RHN90001	NUT		A6	RQT2589-B	INSTRUCTION MANUAL	(GN)
23	XTB3+8JFZ	SCREW		A7	RQX7433ZA	WARRANTY CARD	(GN)
24	XTW3+15T	SCREW		A7	RQA0013	WARRANTY CARD	(E, EB, EG)
25	RHD30007	SCREW		A8	RQCB0169	SERVICE CENTER LIST	
26	XTBS3+8JFZ1	SCREW		A9	RSA0007	FM INDOOR ANTENNA	
27	RHD26016	SCREW		A10	RSA0012	AM LOOP ANTENNA	
29	XTBS26+10J	SCREW		A10-1	RMNO244	ANTENNA HOLDER	
30	XTB3+10JFZ	SCREW		A10-2	XTN2+12AFZ	SCREW	
31	XTB3+20JFZ	SCREW		A11	SJP9009	ATTACHMENT PLUG	(EB)
32	RMNO190	HOLDER	(GC)	A12	SJP5213-2	POWER PLUG ADAPTOR	(GC)
33	RMNO282	FAN ANGLE	(GC)	A13	RFE0014	ANTENNA PLUG	(GC, GN)
34	SYE1128-4	FAN	(GC)				
34-1	SHE232	FAN	(GC)				
34-2	SUS271	SPRING	(GC)				
34-3	SHE233-1	FAN CASE	(GC)				
34-4	MDN-4RB4MRC	MOTOR	(GC)				
34-5	SHE234	CAP	(GC)				
34-6	SJT783	TERMINAL	(GC)				
34-7	SJS5215	CONNECTOR (2P)	(GC)				
35	XTB3+12JFZ	SCREW	(GC)				
36	RMNO191	HOLDER					
		PACKING MATERIALS					
P1	RPG2146	PACKING CASE (SYSTEM)	(E, EG)				
P1	RPG2147	PACKING CASE (SYSTEM)	(EB)				
P1	RPG2148	PACKING CASE (SYSTEM)	(GC)				
P1	RPG2150	PACKING CASE (SYSTEM)	(GN)				
P2	RPG2231	PACKING CASE (DECK)					

■ Packaging

