

Service Manual

Amplifier

Amplifier

SE-CH540

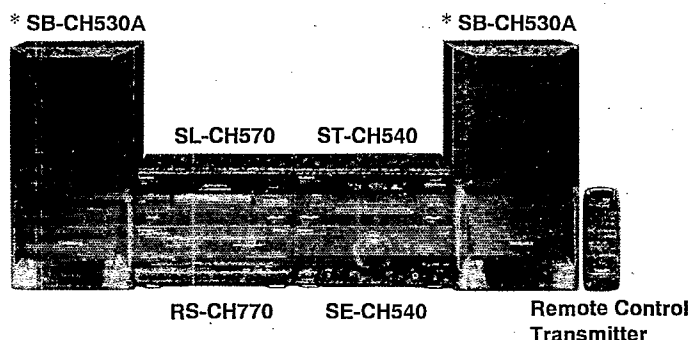

Colour

(K) : Black

Areas

Suffix for Model No.	Area	Colour
(E), (EP)	Europe	(K)
(EB)	Britain	
(EG)	Germany and Italy	

Because of unique interconnecting cables, when a component requires service, send or bring in the entire system.

System: SC-CH540

Specifications

Power output

DIN 1 kHz, THD 1%, both channels driven
2 × 35 W (6 Ω)

RMS 1 kHz, THD 10%, both channels driven
2 × 48 W (6 Ω)

Total harmonic distortion

Rated power at 1 kHz 1% (6 Ω)

Half power at 1 kHz 0.09% (6 Ω)

Load impedance

6 Ω – 8 Ω

S/N (rated power)

90 dB

General

Power consumption

114 W

Power supply

[For (E), (EG) and (EP) areas] 230 V, AC 50/60 Hz

[For (EB) area] 230 – 240 V, AC 50/60 Hz

Dimensions (W × H × D) 270 × 118.5 × 341.5 mm

Weight 3.9 kg

Notes:

Specifications are subject to change without notice.

Weight and dimensions are approximate.

Total harmonic distortion is measured by the digital spectrum analyzer.

System	Tuner/sound processor	Compact disc player	Amplifier	Cassette deck	Speakers
SC-CH540	ST-CH540	SL-CH570	SE-CH540	RS-CH770	*SB-CH530A

*: Made in PAES

WARNING

This service information is designed for experienced repair technicians only and is not designed for use by the general public. It does not contain warnings or cautions to advise non-technical individuals of potential dangers in attempting to service a product.

Products powered by electricity should be serviced or repaired only by experienced professional technicians. Any attempt to service or repair the product or products dealt with in this service information by anyone else could result in serious injury or death.

Technics®

© 1996 Matsushita Electric Industrial Co., Ltd.
All rights reserved. Unauthorized copying
and distribution is a violation of law.

Contents

	Page		Page
Before Repair	2	Operation Check and	
Protection Circuitry	2	Main Component Replacement Procedures	7, 8
Accessories	2	Power Source ON/OFF of This Unit	9
Caution of AC Mains Lead	3	Schematic Diagram	9~11
Location of Controls	3	Printed Circuit Board Diagram	12~14
Installation	4	Wiring Connection Diagram	14
Flat Cable Connections	4	Block Diagram	15
Antenna Connections	5	Replacement Parts List	16~18
External Unit Connection	5	Cabinet Parts Location	19
Optional Antenna Connections	6	Packaging	20
Connection of AC Power Supply Cord	6		

Before Repair

- (1) Turn off the power supply. Using a 10 Ω , 10 W resistor, connect both ends of power supply capacitors (C701, C702) in order to discharge the voltage.
- (2) Before turning the power supply on, after completion of repair, slowly apply the primary voltage by using a power supply voltage controller to make sure that the consumed current at 50/60 Hz in NO SIGNAL mode should be shown below with respect to supply voltage 230 V/240 V.

Power supply voltage	AC 230 V	AC 240 V
Consumed current 50 Hz	60 ~ 200 mA	60 ~ 200 mA

Protection Circuitry

The protection circuitry may have operated if either of the following conditions is noticed:

- * No sound is heard when the power is switched ON.
- * Sound stops during a performance.

The functions of this circuitry is to prevent circuitry damage if, for example, the positive and negative speaker connection wires are "shorted", or if speaker systems with an impedance less than the indicated rated impedance of this unit are used.

If this occurs, follow the procedure outlined below:

1. Switch OFF the power.
2. Determine the cause of the problem and correct it.
3. Switch ON the power once again.

Note:
When the protection circuitry functions, the unit will not operate unless the power is first switched OFF and then ON again.

Accessories

- AC power supply cord
(E), (EG) and (EP) areas : (RJA0019-2K) .. 1
(EB) area : (RJA0049-K) .. 1
- Flat cable
Long (REX0661) .. 1
Medium (REX0660) .. 1
Short (REX0608) .. 1
- Remote control transmitter
(RAK-CH204WH) .. 1
- Batteries
(UM-4, "AAA", R03) .. 2
- AM (LW/MW) loop antenna
(RSA0012) .. 1
- Antenna holder
(RMN0244) .. 1
- Note:** These are available on sales route.
- Mounting screw
(XTN3+12AFZ) .. 1
- FM indoor antenna
(RSA0007) .. 1
- Speaker cords
(REE0499) .. 2
- Power plug adaptor
for (EB) area only (SJP9009) .. 1

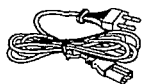

(E), (EG) and (EP)

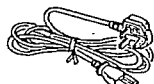

(EB)

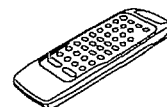

■ Caution for AC Main Lead



[(EB) area code model only]

For your safety, please read the following text carefully.

This appliance is supplied with a moulded three pin mains plug for your safety and convenience.

A 5-ampere fuse is fitted in this plug.

Should the fuse need to be replaced please ensure that the replacement fuse has a rating of 5-ampere and that it is approved by ASTA or BSI to BS1362.

Check for the ASTA mark  or the BSI mark  on the body of the fuse.

If the plug contains a removable fuse cover you must ensure that it is refitted when the fuse is replaced.

If you lose the fuse cover the plug must not be used until a replacement cover is obtained.

A replacement fuse cover can be purchased from your local dealer.

CAUTION!

IF THE FITTED MOULDED PLUG IS UNSUITABLE FOR THE SOCKET OUTLET IN YOUR HOME THEN THE FUSE SHOULD BE REMOVED AND THE PLUG CUT OFF AND DISPOSED OF SAFELY.

THERE IS A DANGER OF SEVERE ELECTRICAL SHOCK IF THE CUT OFF PLUG IS INSERTED INTO ANY 13-AMPERE SOCKET.

If a new plug is to be fitted please observe the wiring code as shown below.

If in any doubt please consult a qualified electrician.

IMPORTANT

The wires in this mains lead are coloured in accordance with the following code:

Blue: Neutral
Brown: Live

As the colours of the wires in the mains lead of this appliance may not correspond with the coloured markings identifying the terminals in your plug, proceed as follows:

The wire which is coloured BLUE must be connected to the terminal in the plug which is marked with the letter N or coloured BLACK.

This apparatus was produced to BS 800.

■ Location of Controls

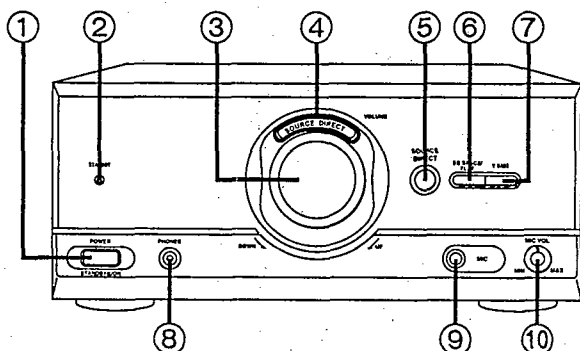

① Power "STANDBY" switch (POWER, STANDBY)

Press to switch the unit from on to standby mode or vice versa. In standby mode, the unit is still consuming a small amount of power.

② Standby indicator (STANDBY)

When the unit is connected to the AC mains supply, this indicator lights up in standby mode and goes out when the unit is turned on.

③ Volume control (VOLUME)

④ Source direct indicator (SOURCE DIRECT)

⑤ Source direct button (SOURCE DIRECT)

⑥ EQ SPACE/flat button (EQ SPACE/FLAT)

⑦ V. bass button (V. BASS)

⑧ Headphones jack (PHONES) (ϕ 3.5, 32 Ω)

⑨ Microphone jack (MIC) (ϕ 6.3, 600 Ω)

⑩ Microphone volume control (MIC VOL)

The wire which is coloured BROWN must be connected to the terminal in the plug which is marked with the letter L or coloured RED.

Under no circumstances should either of these wires be connected to the earth terminal of the three pin plug, marked with the letter E or the Earth Symbol .

Before use

Remove the connector cover as follows.

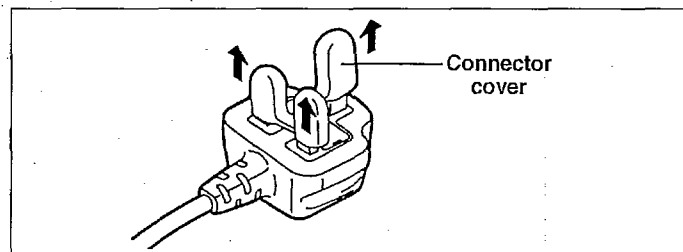

How to replace the fuse

1. Remove the fuse cover with a screwdriver.

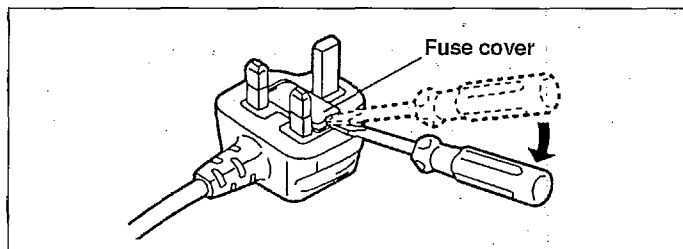

2. Replace the fuse and attach the fuse cover.

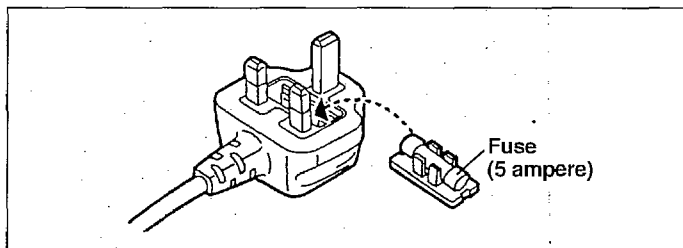

Installation

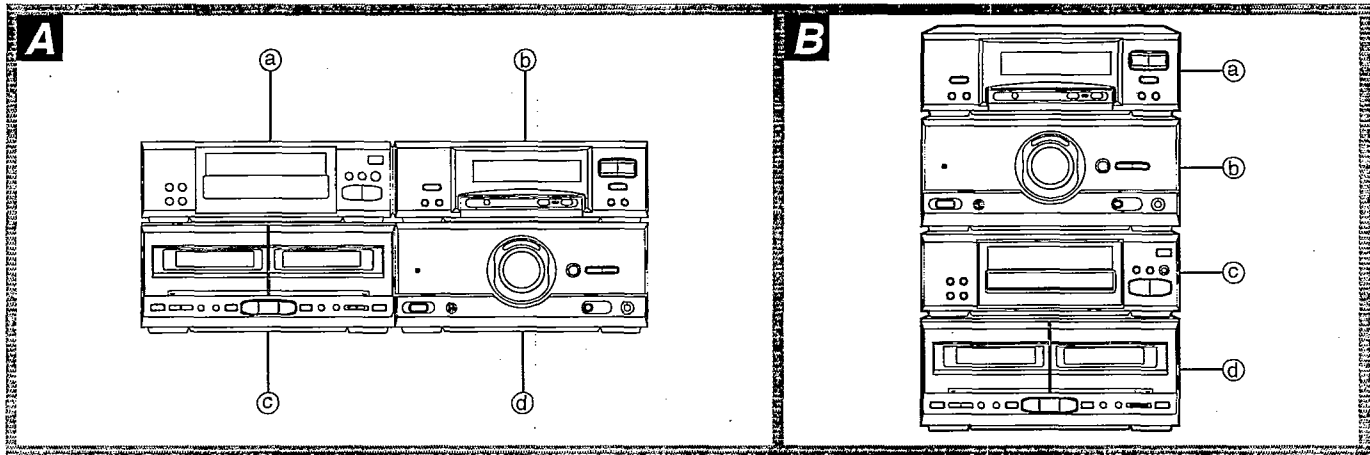

Stacking the components

Horizontal stacking **A**

- Ⓐ CD player
- Ⓑ Tuner/sound processor
- Ⓒ Cassette deck
- Ⓓ Amplifier

Vertical stacking **B**

- Ⓐ Tuner/sound processor
- Ⓑ Amplifier
- Ⓒ CD player
- Ⓓ Cassette deck

Flat Cable (included) Connections

Before marking connections:

Make sure the white line on the cable is on the right side.

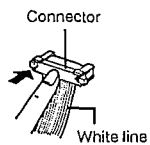

To unplug cables:

Hold the connector from both ends.

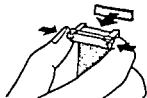

Note Do not try connecting or disconnecting the flat cables while the power is switched to ON.

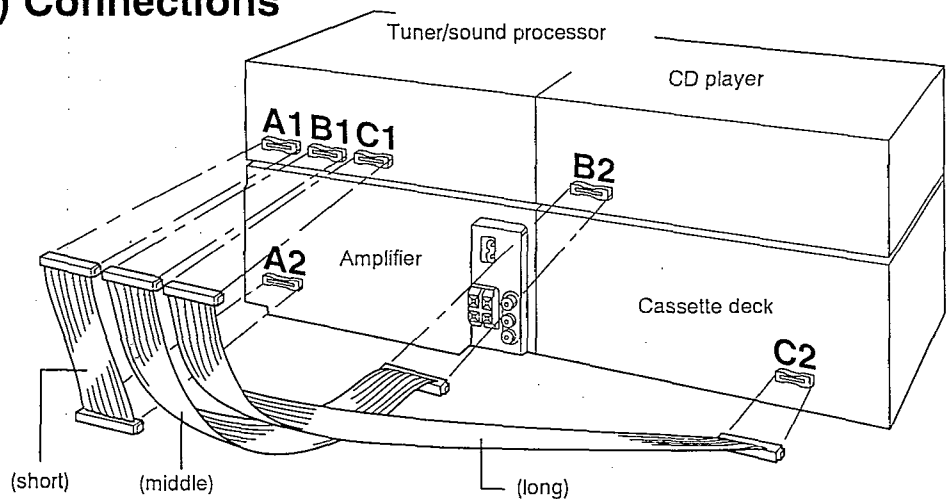

After connection:

Fold and press the cable as flat to the back of the unit as possible. (To minimize noise pickup while listening an MW/LW broadcast)

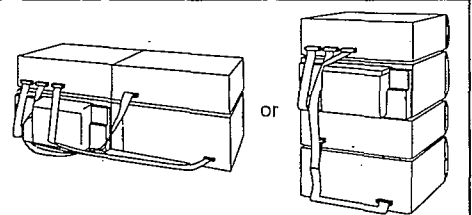

Antenna Connections

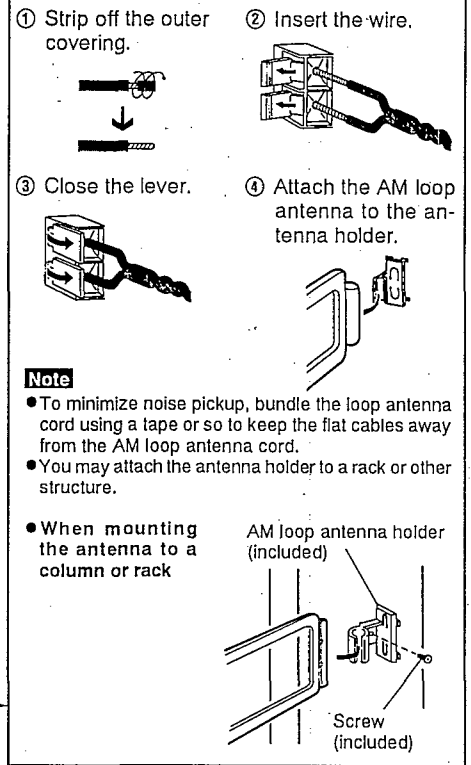
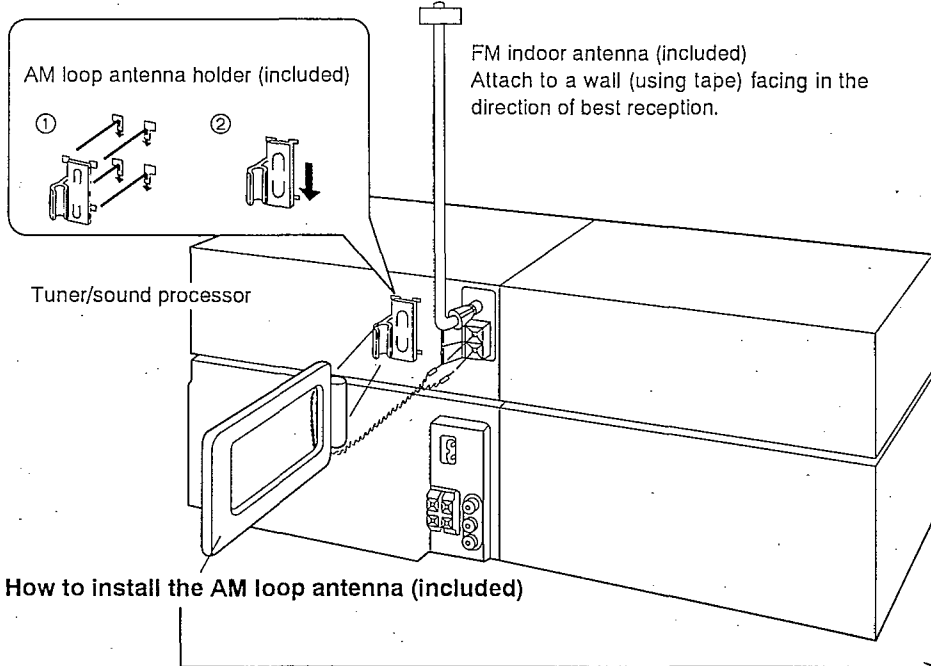

External Unit Connections

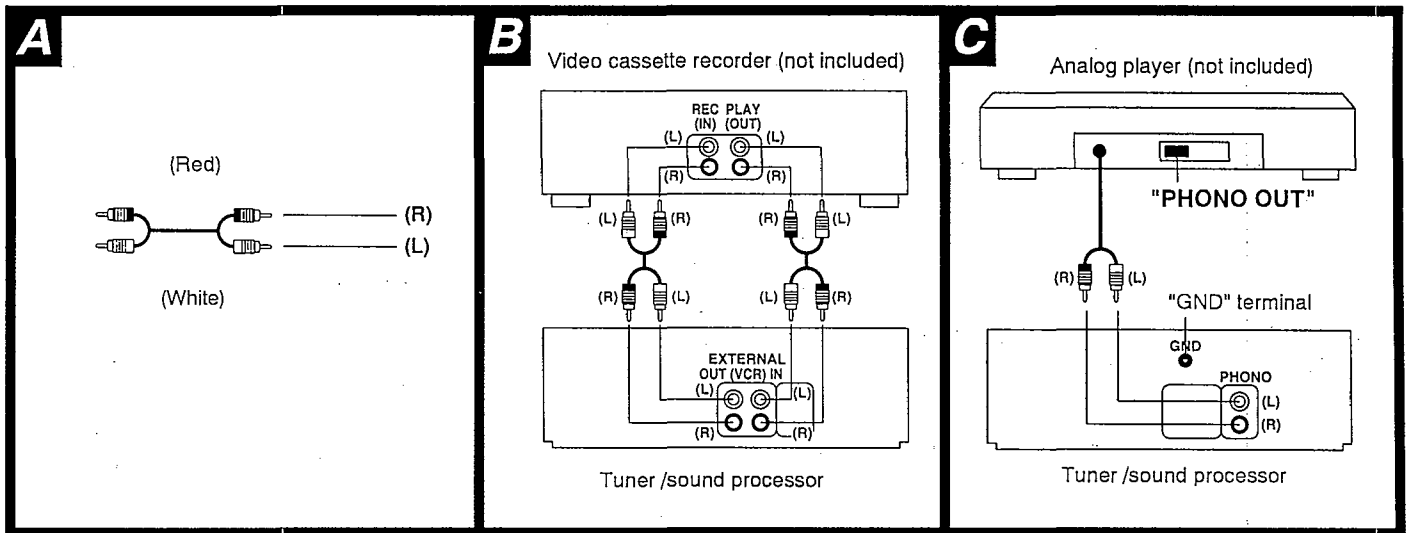

- Make sure that the power supply for all components has been turned off before making any connections.
- For details, refer to the operating instructions of the units which are to be connected.
- When units other than those described below are to be connected, please consult with your audio dealer.

Connecting the stereo connection cable (not included)
Connect the red plug to the right (R) connector.
Connect the white plug to the left (L) connector.

Video cassette recorder

Analog player

This example shows how to connect the analog player with the PHONO OUT/LINE OUT switch.

Set the switch to the "PHONO OUT" position at the back of the analog player.
"GND" terminal is for a ground wire use.

Optional Antenna Connections

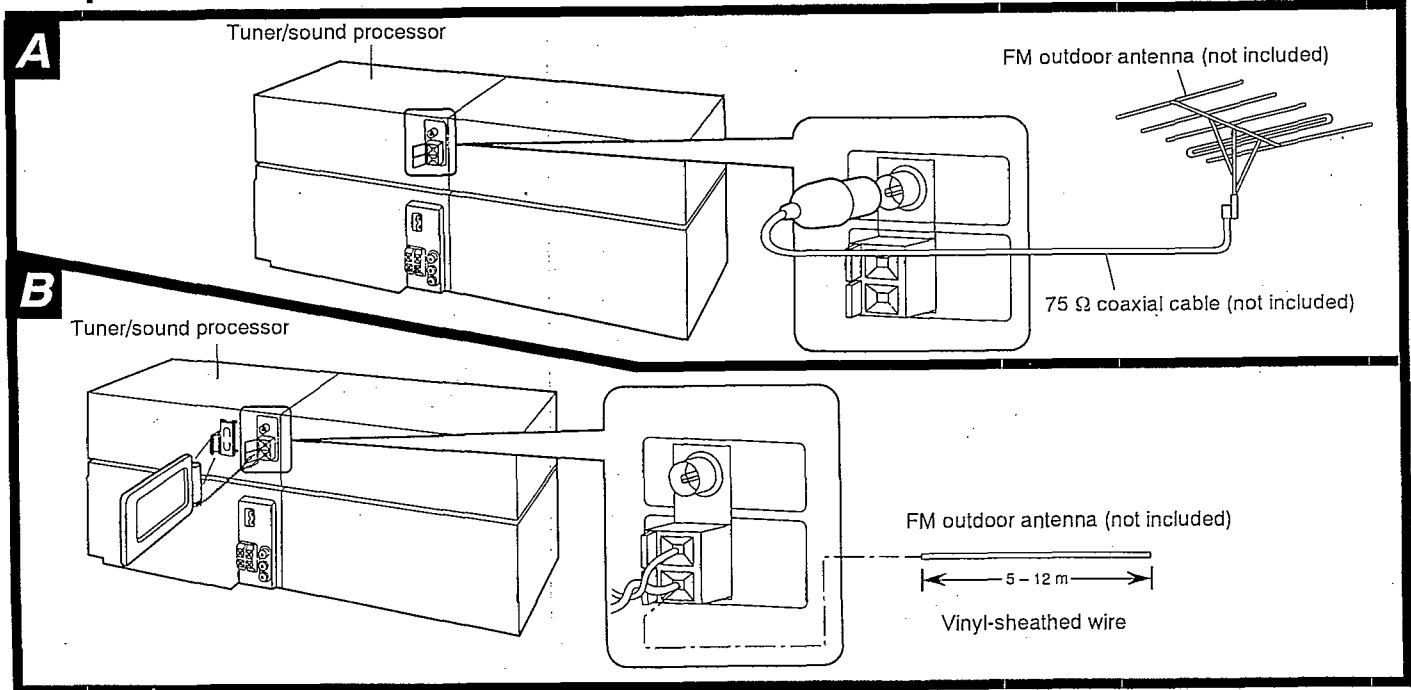

FM outdoor antenna (not included)

The outdoor antenna should be used when using this unit in mountainous areas or in spaces enclosed by reinforced concrete where the FM indoor antenna (included) does not provide satisfactory reception.

Note

An outdoor antenna should be installed by a qualified technician only.

AM (MW/LW) outdoor antenna (not included)

The outdoor antenna should be used when using this unit in mountainous areas or in spaces enclosed by reinforced concrete where the AM loop antenna (included) does not provide satisfactory reception.

Use 5-12 m of vinyl-sheathed wire horizontally at the window, or a convenient location.

When the unit is not in use, disconnect the outdoor antenna to prevent possible damage from lightning. Never use an outdoor antenna during an electrical storm.

Note

Be sure to connect the AM loop antenna even when an outdoor antenna is used.

Connection of AC Power Supply Cord

- Plug the cord into an outlet only after all other connections have been made.

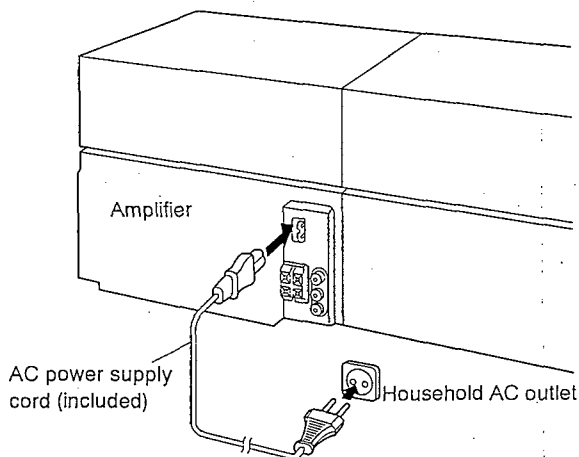

Insertion of Connector:

Even when the connector is perfectly inserted, depending on the type of inlet used, the front part of the connector may jut out as shown in the drawing.

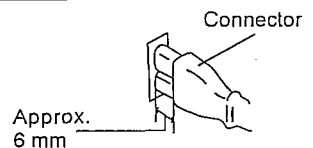

Operation Check and Main Component Replacement Procedures

NOTE

1. This section describes procedures for checking the operation of the major printed circuit boards and replacing the main components.
2. For reassembly after operation checks or replacement, reverse the respective procedures. Special reassembly procedures are described only when required.
3. Select items from the following index when checks or replacement are required.
4. Illustrated screws are equivalent to actual size.
5. Refer the parts No. on the page of "Main Component Replacement Procedures", if necessary.

Contents

•Checking Procedures for each P.C.B.

1. Checking for the operation P.C.B.	Page. 7.
2. Checking for the main P.C.B.	8.

•Main Component Replacement Procedures



1. Replacement for the power IC and regulator transistor.	8.
--	----

Checking Procedure for each P.C.B.

1. Checking for the operation P.C.B.

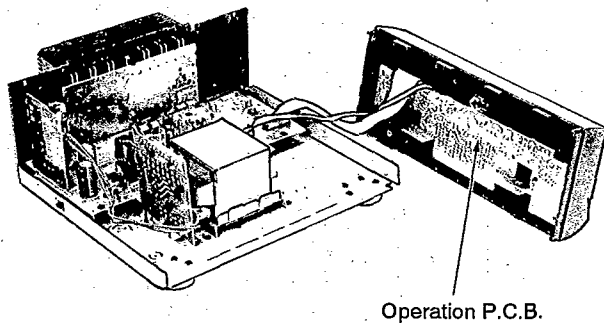
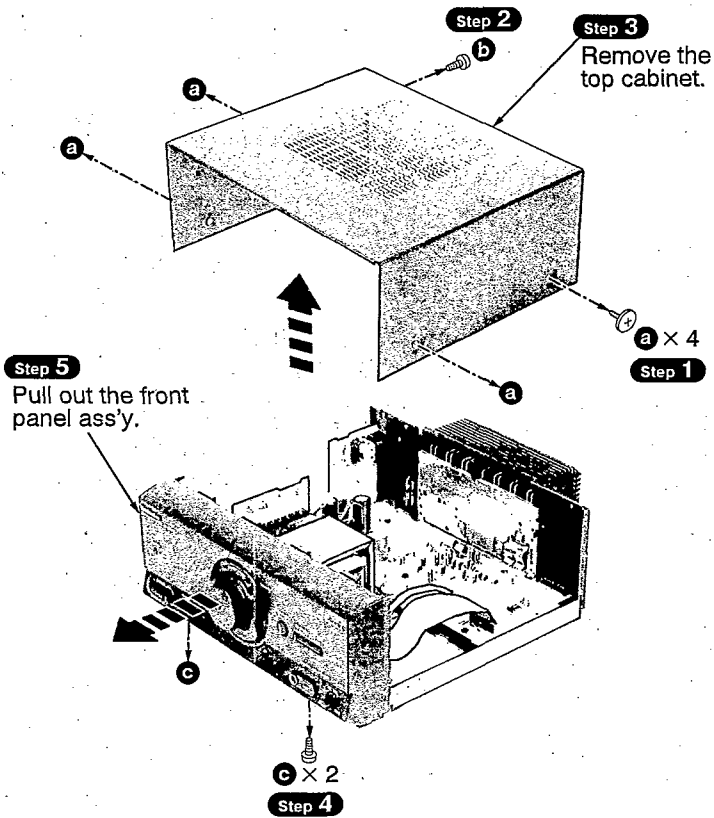
• Check the operation P.C.B. as shown below.



-  a
[RHD30007-K1] (Black)
-  b
[XTBS3+10JFZ1] (Black)
-  c
[XTBS3+8JFZ1] (Black)

2. Checking for the main P.C.B.

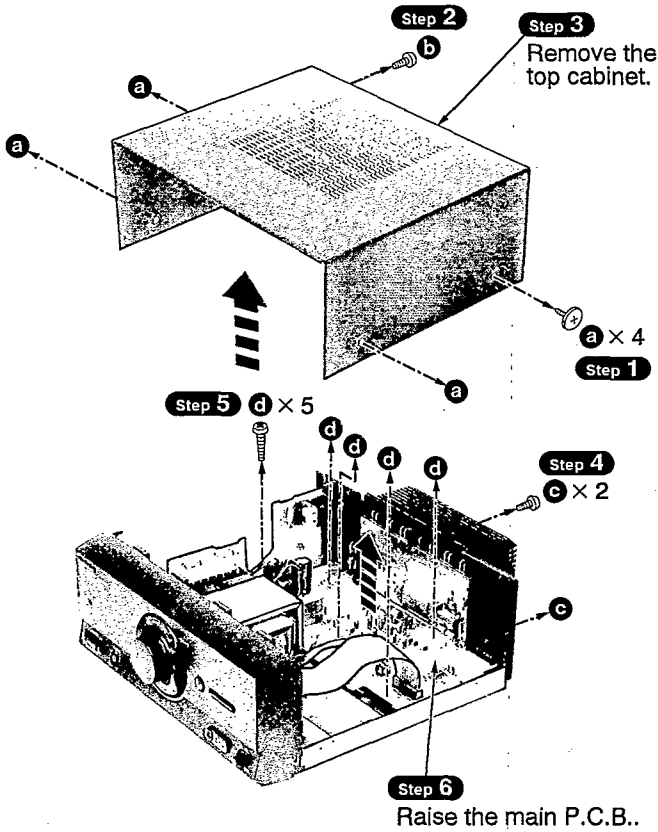

- a
[RHD30007-K1] (Black)
- b
[XTBS3+10JFZ1] (Black)
- c
[XTB3+10JFZ] (Black)
- d
[XTB3+20JFZ] (Black)

• Check the main P.C.B. as shown below.

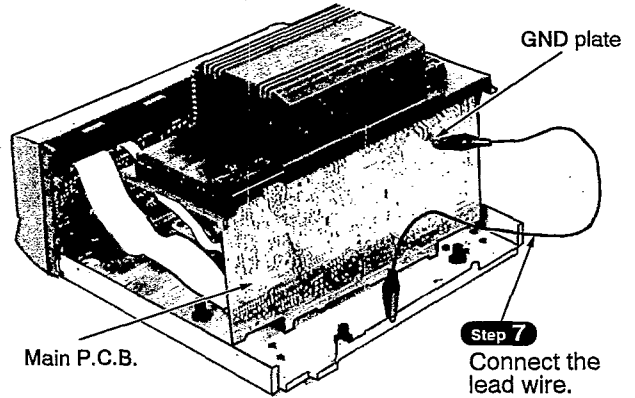

■ Main Component Replacement Procedures

1. Replacement for the power IC and regulator transistor

• Follow the item 2 (Step 1 ~ Step 6) checking procedures for each P.C.B..

NOTE

When mounting the power IC or regulator transistor, apply silicone compound (RFKX0002) to the rear side of power IC or regulator transistors.

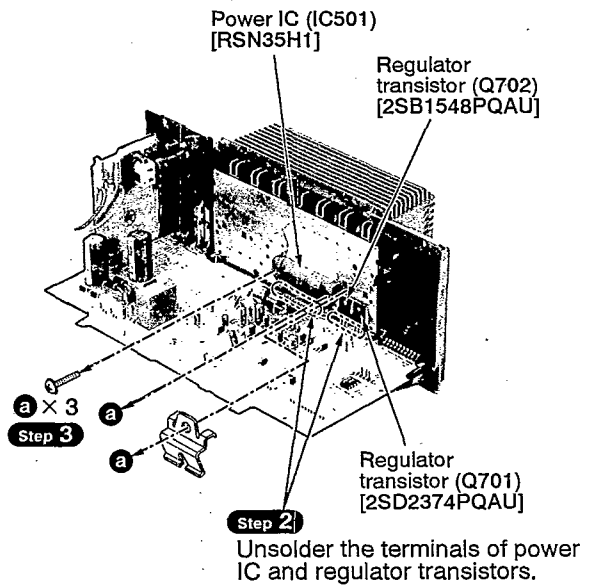
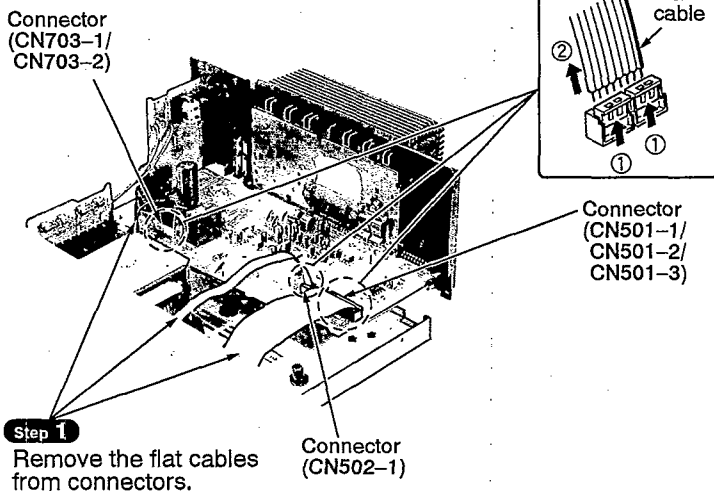

[XTW3+15T]

■ Power Source ON/OFF of This Unit

1. Connect the AC power cord of this unit to an AC outlet and turn it on.
(This unit comes to stand-by mode.)
2. Make test point **TP701** short as shown in Fig. 1.
This unit comes to power ON mode.

Operation Check

1. Set this unit to power ON mode.
2. Input a signal (1 kHz, 100 mV) to the section between the jumper **J603** (LINE IN for L-ch) and the jumper **J308** (LINE IN GND) as well as the section between the jumper **J604** (LINE IN R-ch) and the jumper **J308**.
3. Connect the speaker to the speaker terminals and check if it sounds from the speaker.

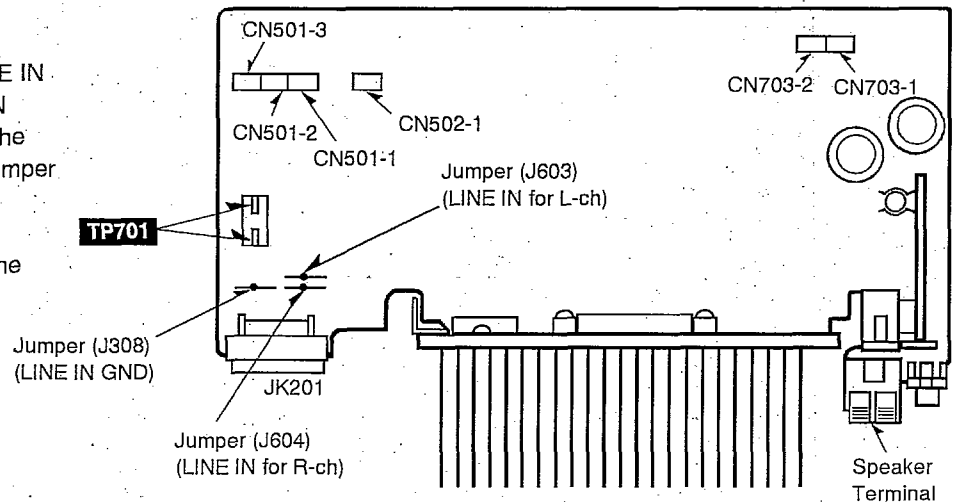

Fig. 1

■ Schematic Diagram

	Page
A OPERATION CIRCUIT	10
B MAIN CIRCUIT	10, 11
C POWER TRANSFORMER CIRCUIT	11
D AC IN TERMINAL CIRCUIT	11

• This schematic diagram may be modified at any time with the development of new technology.

Notes:

- **S601** : Power "STANDBY ϕ /ON" switch (POWER STANDBY ϕ /ON)
- **S606** : SOURCE DIRECT switch
- **S607** : EQ SPACE/FLAT switch
- **S608** : V. BASS switch
- **VR401** : Microphone volume control (MIC VOLUME)
- **VR601** : Volume control (VOL)

• Indicated voltage values are the standard values for the unit measured by the DC electronic circuit tester (high-impedance) with the chassis taken as standard. Therefore, there may exist some errors in the voltage values, depending on the internal impedance of the DC circuit tester.
No mark: Power ON

• Important safety notice:

Components identified by Δ mark have special characteristics important for safety.

Furthermore, special parts which have purposes of fire-retardant (resistors), high-quality sound (capacitors), low-noise (resistors), etc. are used. When replacing any of components, be sure to use only manufacturer's specified parts shown in the parts list.

• Caution!

IC and LSI are sensitive to static electricity.

Secondary trouble can be prevented by taking care during repair.

Cover the parts boxes made of plastics with aluminum foil.

Ground the soldering iron.

Put a conductive mat on the work table.

Do not touch the legs of IC or LSI with the fingers directly.

• Voltage and signal line

- $\overline{\hspace{1cm}}$: Positive voltage line
- $\overline{\hspace{1cm}}$: Source signal Line (L-ch)
- $\overline{\hspace{1cm}}$: Negative voltage line
- $\overline{\hspace{1cm}}$: Mic signal

A OPERATION CIRCUIT (P.C.Board: on page 13)

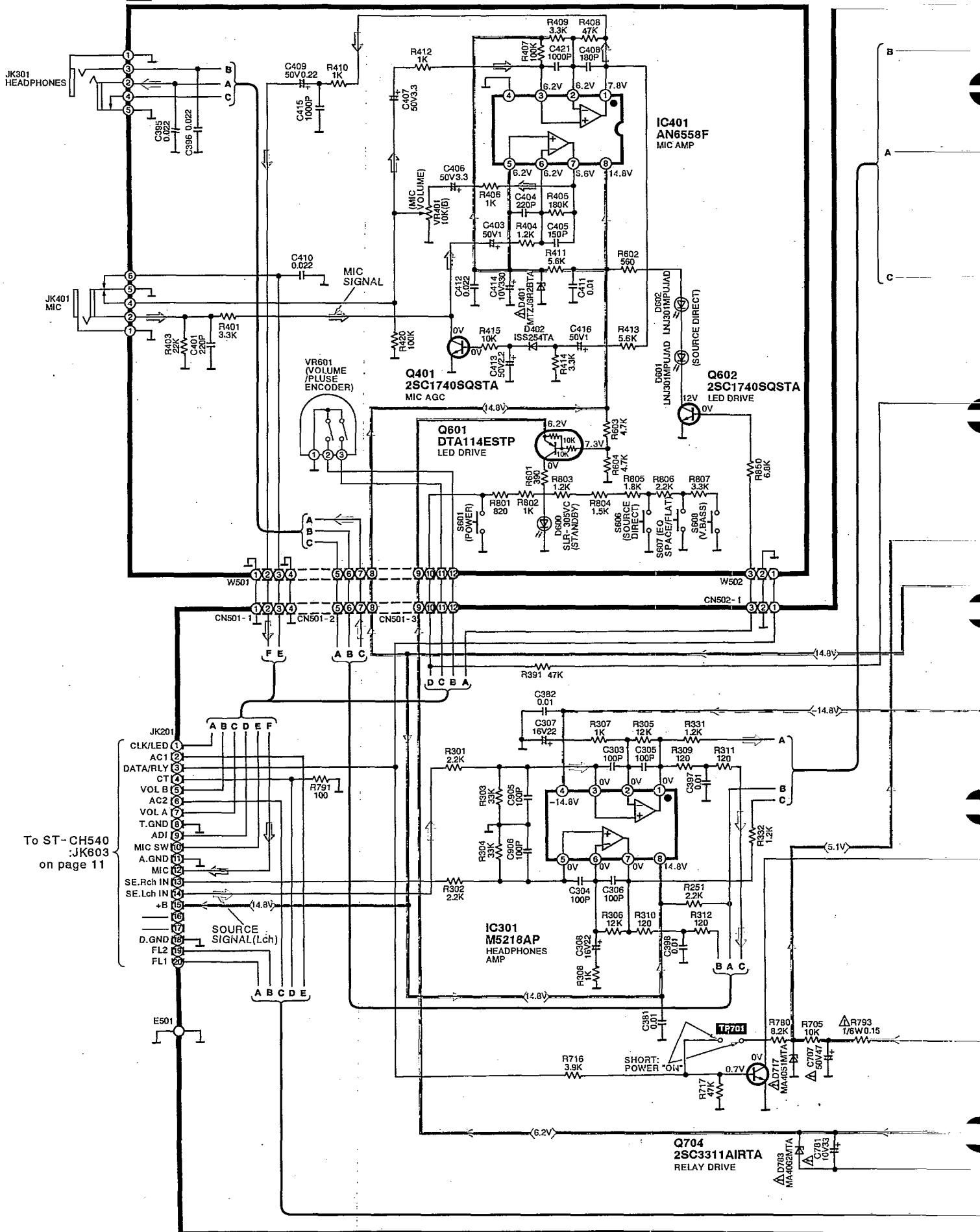

To ST-CH540 :JK603 on page 11

→ : Source signal Line (L-ch) → : Mic signal

B MAIN CIRCUIT (P.C.Board: on page 12)

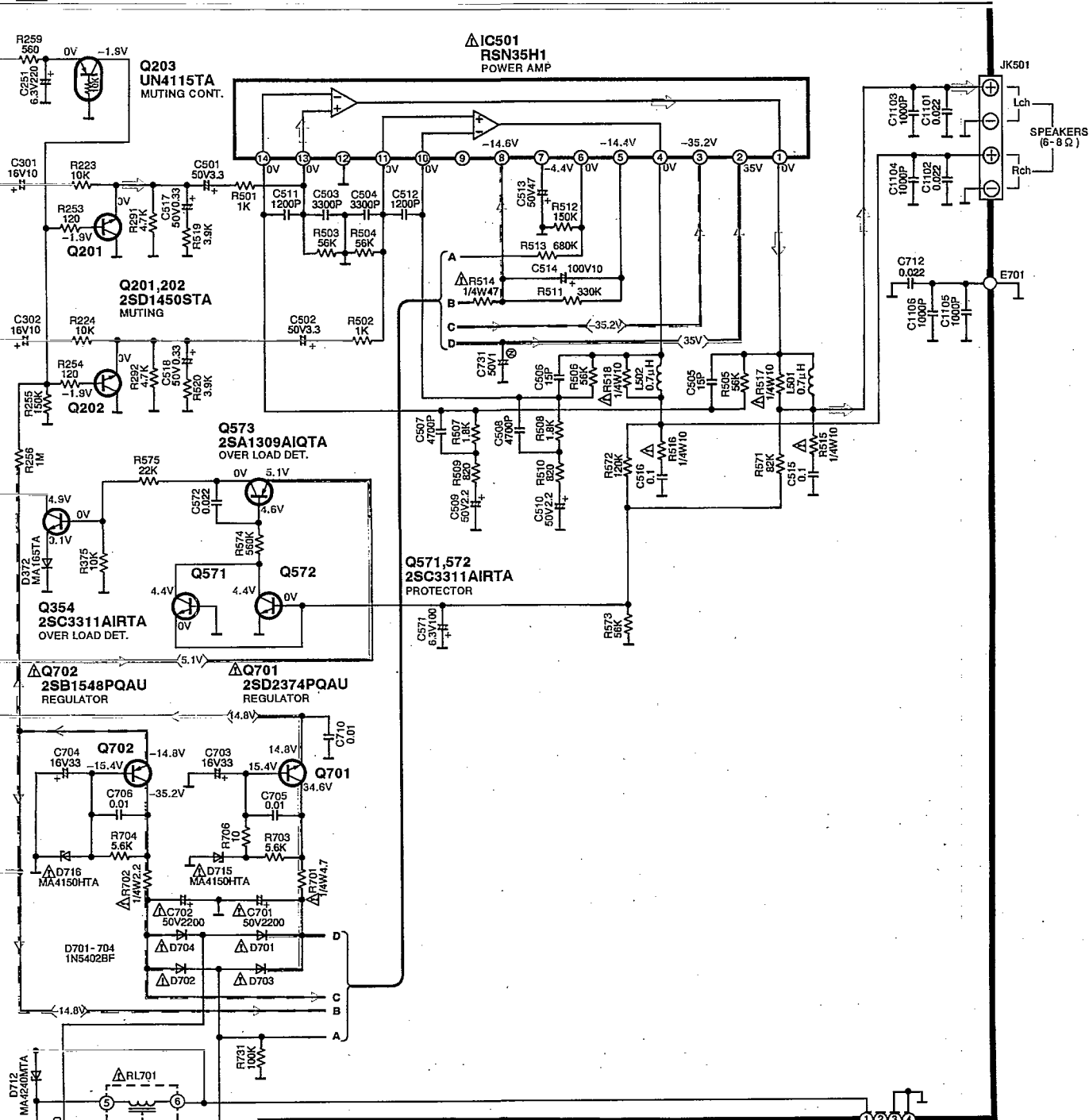

C POWER TRANSFORMER CIRCUIT (P.C.Board: on page 13)

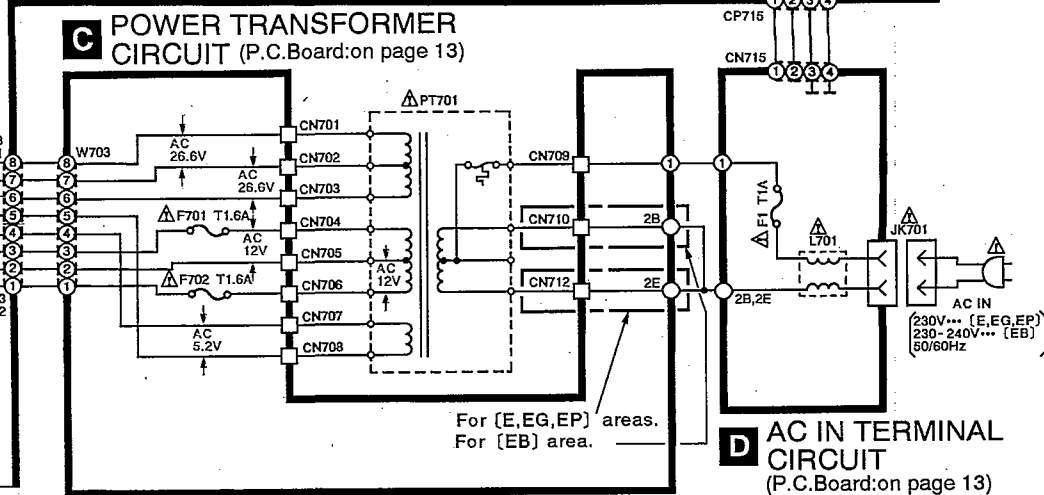

D AC IN TERMINAL CIRCUIT (P.C.Board: on page 13)

Printed Circuit Board Diagram

This circuit board diagram may be modified at any time with the development of new technology.

B MAIN P.C.B. (REP2107D-M)

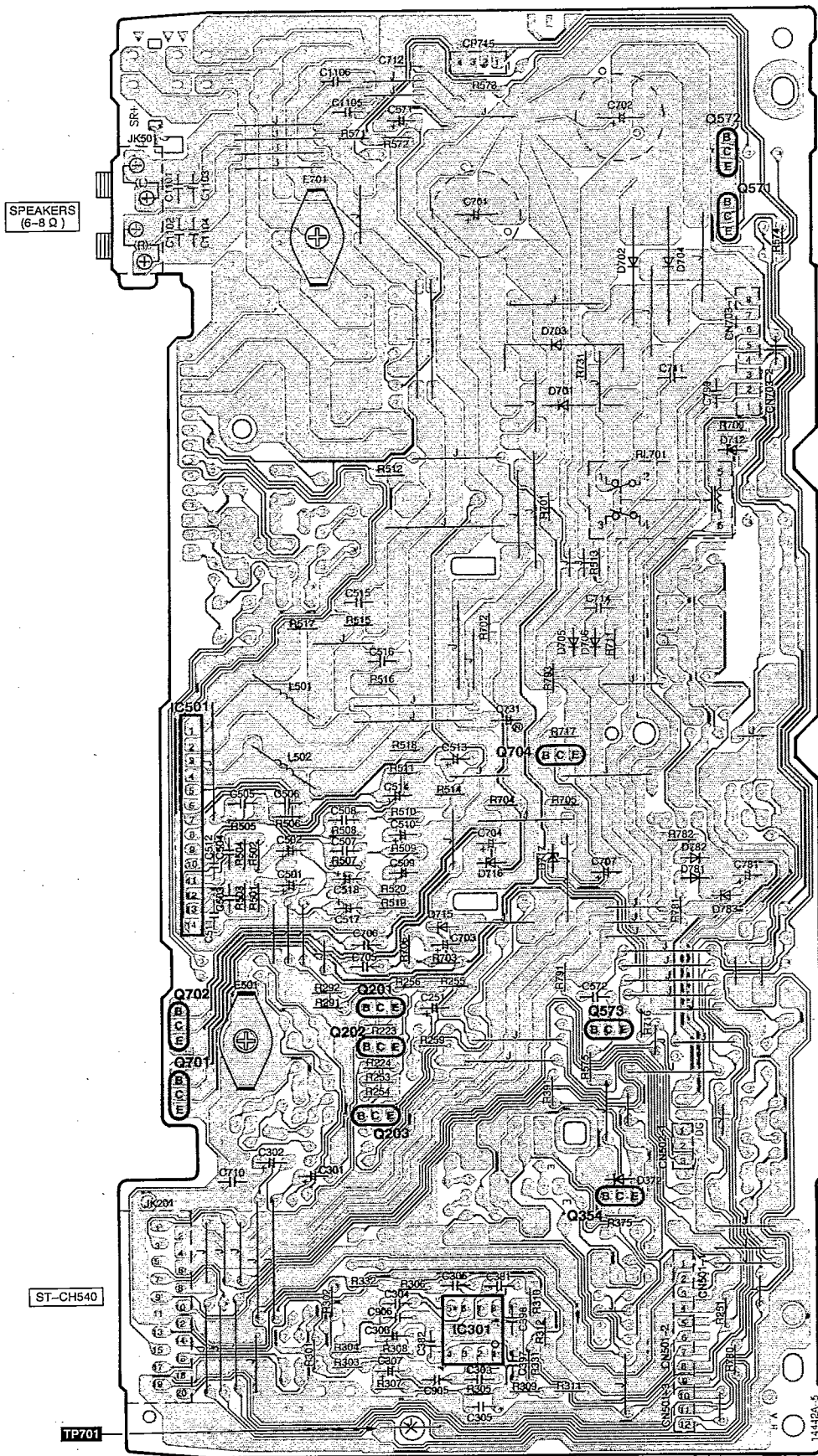

A OPERATION P.C.B.
(REP2108A-S)

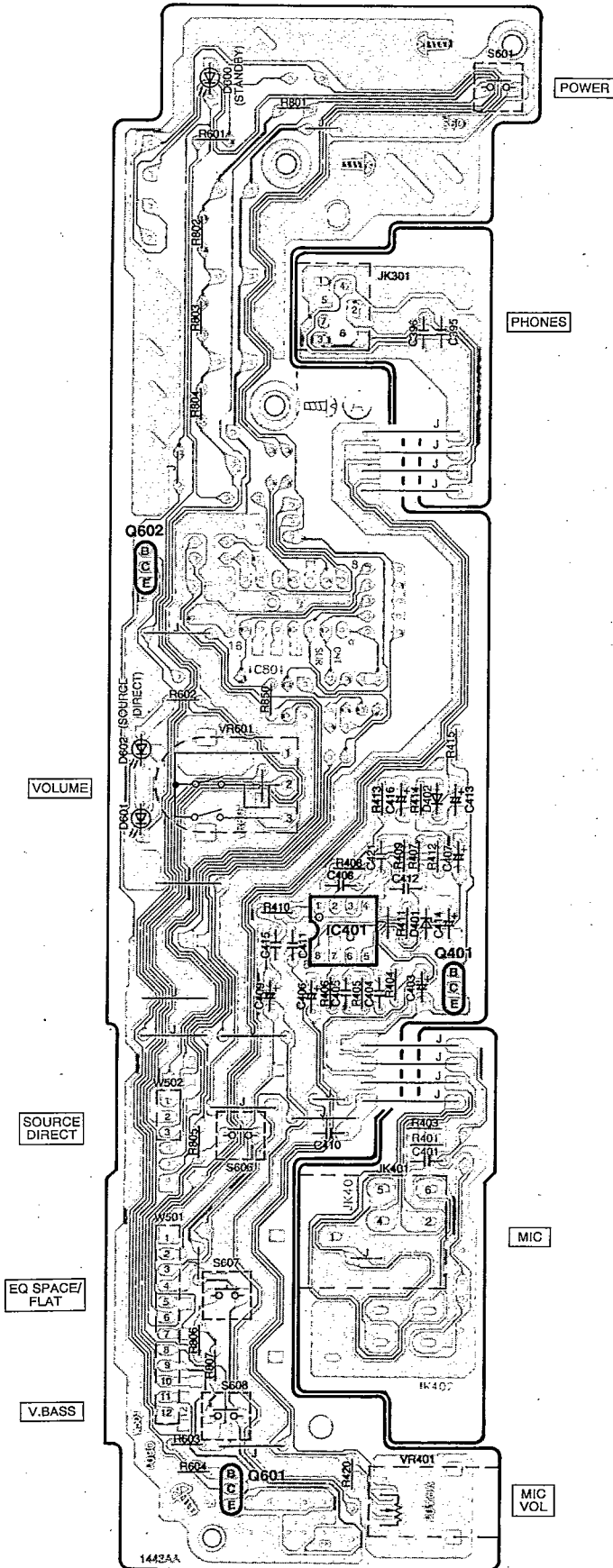

C POWER TRANSFORMER P.C.B.
(REP2109A-P...[E,EG,EP])
(REP2109B-P...[EB])

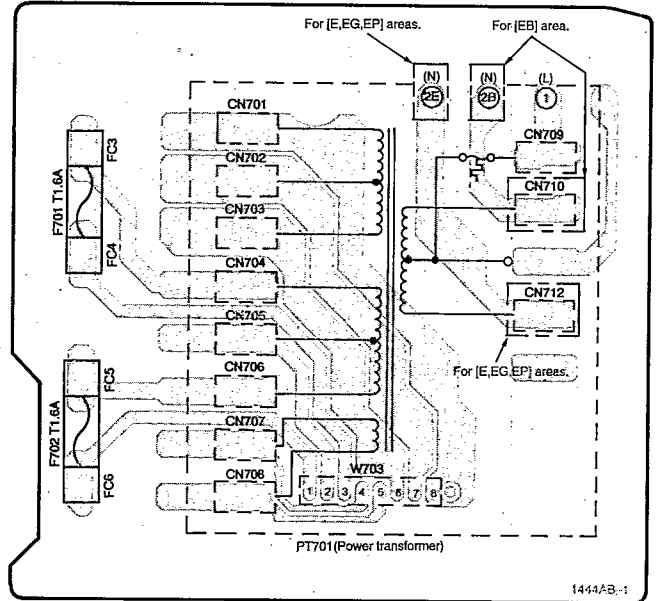

D AC IN TERMINAL P.C.B. (REP2109A-P...[E,EG,EP])
(REP2109B-P...[EB])

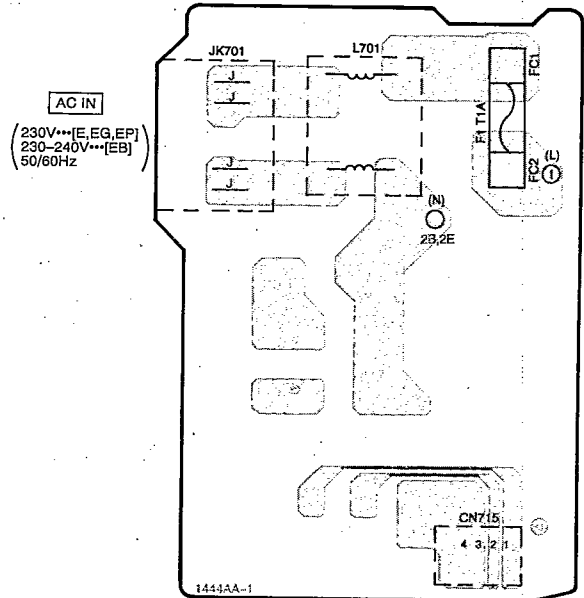

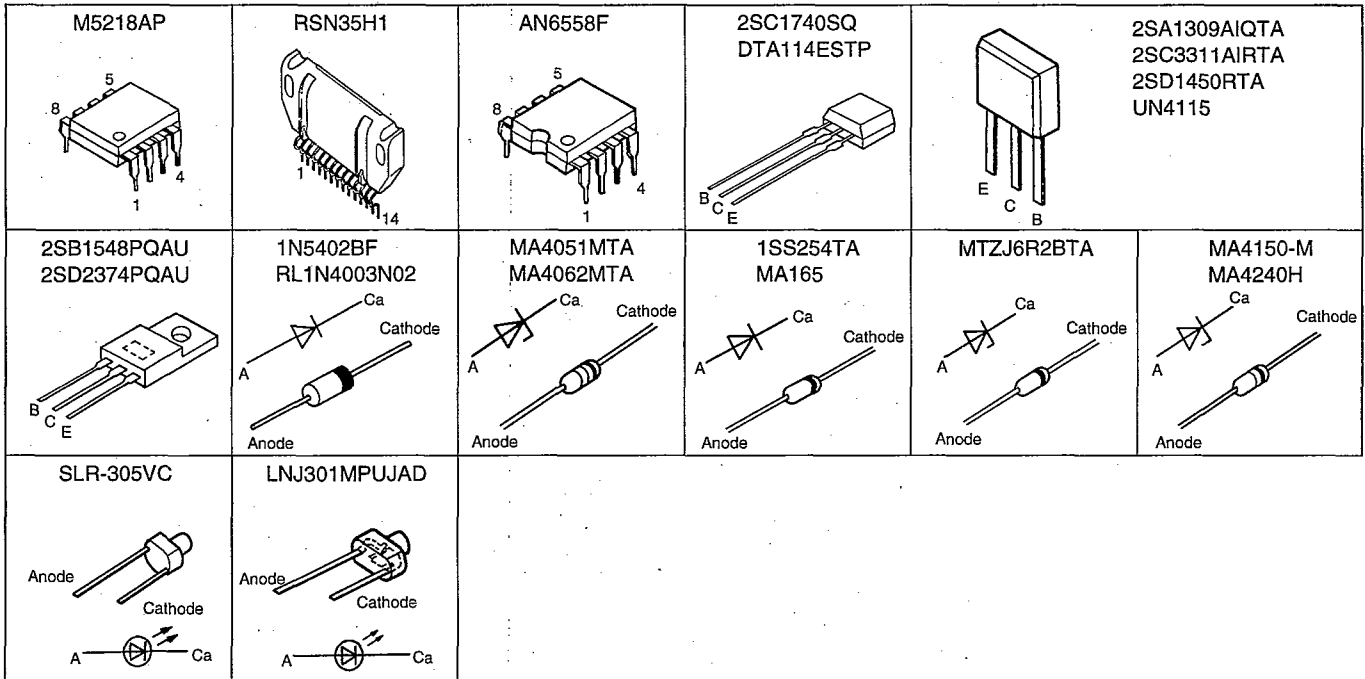

Wiring Connection Diagram

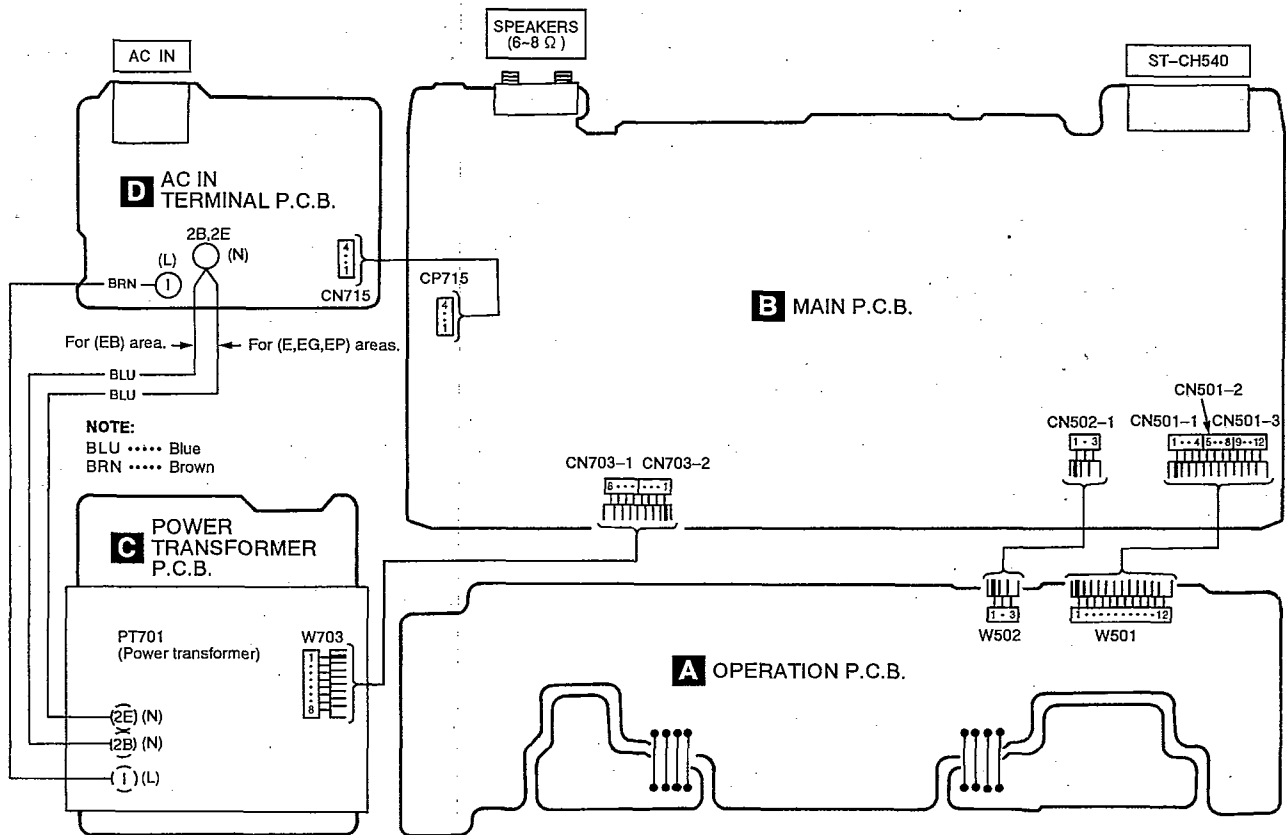

Block Diagram

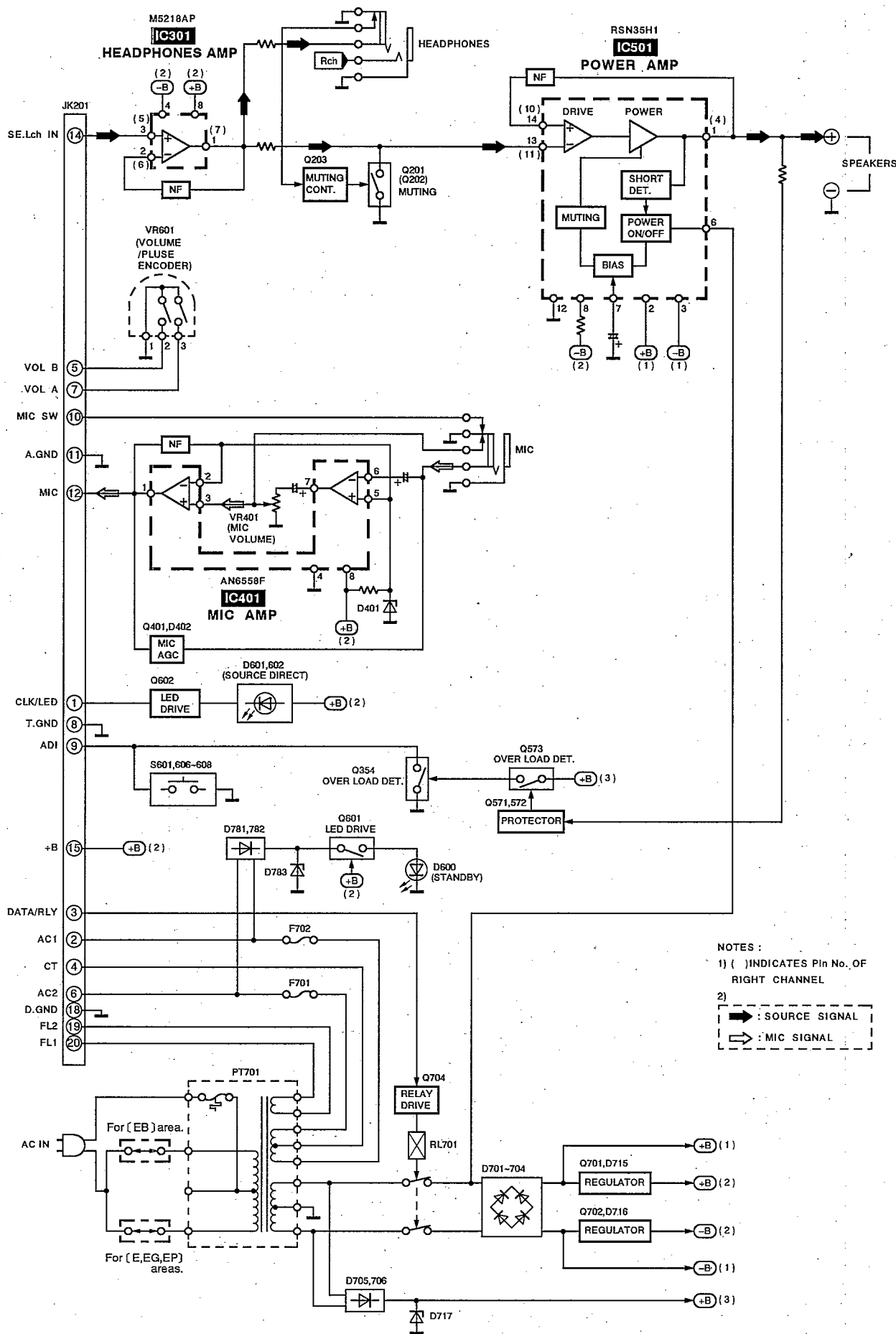

Replacement Parts List

Notes: *Important safety notice:

 Components identified by Δ mark have special characteristics important for safety.

Furthermore, special parts which have purposes of fire-retardant (resistors), high-quality sound (capacitors), low-noise (resistors), etc. are used.

When replacing any of components, be sure to use only manufacturer's specified parts shown in the parts list.

*The parenthesized indications in the Remarks columns specify the areas. (Refer to the cover page for area.)

Parts without these indications can be used for all areas.

*Remote Control Ass'y: Supply period for three years from termination of production.

*The "(SF)" mark denotes the standard part.

Ref. No.	Part No.	Part Name & Description	Remarks	Ref. No.	Part No.	Part Name & Description	Remarks
		INTEGRATED CIRCUIT(S)		S601	EVQ21405R	SW, POWER	
IC301	M5218AP	IC, HEADPHONES AMP.		S606	EVQ21405R	SW, SOURCE DIRECT	
IC401	AN6558F	IC, MIC AMP.		S607	EVQ21405R	SW, EQ SPACE/FLAT	
IC501	RSN35H1	IC, POWER AMP.	Δ	S608	EVQ21405R	SW, V. BASS	
		TRANSISTOR(S)				CONNECTOR(S)	
Q201, 202	2SD1450RTA	TRANSISTOR		CN501-1	RJS1A6604	CONNECTOR(4P)	
Q203	UN4115	TRANSISTOR		CN501-2	RJS1A6604	CONNECTOR(4P)	
Q354	2SC3311AIRTA	TRANSISTOR		CN501-3	RJS1A6604	CONNECTOR(4P)	
Q401	2SC1740SQ	TRANSISTOR		CN502-1	RJS1A6603	CONNECTOR(3P)	
Q571, 572	2SC3311AIRTA	TRANSISTOR		CN703-1	RJS1A6604	CONNECTOR(4P)	
Q573	2SA1309A1QTA	TRANSISTOR		CN703-2	RJS1A6604	CONNECTOR(4P)	
Q601	DTA114ESTP	TRANSISTOR		CN701-709	RJS1A1101T1	CONNECTOR(1P)	
Q602	2SC1740SQ	TRANSISTOR		CN710	RJS1A1101T1	CONNECTOR(1P)	(EB)
Q701	2SD2374PQAU	TRANSISTOR	Δ	CN712	RJS1A1101T1	CONNECTOR(1P)	(E, EG, EP)
Q702	2SB1548PQAU	TRANSISTOR	Δ	CN715	RJU057W004	CONNECTOR(4P)	
Q704	2SC3311AIRTA	TRANSISTOR		CP715	RJT057W004-1	CONNECTOR(4P)	
		DIODE(S)				GND PLATE	
D372	MA165	DIODE		E501	SNE1004-2	GND PLATE	
D401	MTZJ6R2BTA	DIODE	Δ	E701	SNE1004-2	GND PLATE	
D402	1SS254TA	DIODE				FUSE HOLDER(S)	
D600	SLR-305VC	L. E. D.		FC1-6	EYF52BC	FUSE HOLDER	
D601, 602	LNJ301MPUJAD	L. E. D.				POWER TRANSFORMER	
D701-704	1N5402BF	DIODE	Δ	PT701	RTP2M5B007	POWER TRANSFORMER	Δ
D705, 706	RL1N4003N02	DIODE	Δ			RELAY	
D712	MA4240H	DIODE		RL701	RSY0013M-0	RELAY	Δ
D715, 716	MA4150M	DIODE	Δ			JACK(S)	
D717	MA4051MTA	DIODE	Δ	JK201	RJT065K20	SYSTEM CONNECTOR(20P)	
D781, 782	MA165	DIODE	Δ	JK301	RJJ37TN01-C	HEADPHONES JACK	
D783	MA4062MTA	DIODE	Δ	JK401	RJJ65MA01	MIC JACK	
		VARIABLE RESISTOR(S)		JK501	RJRO054M	SP TERMINAL	
VR401	RRV11A01B14A	V. R, MIC VOLUME CONTROL		JK701	SJS9236	AC INLET	Δ
VR601	EVQWVF2024B	V. R, MAIN VOLUME CONTROL					
		COIL(S)					
L501, 502	RLQYR73M	COIL					
L701	RLQZ271M	COIL	Δ				
		FUSE(S)					
F1	XBA2C10TBO	FUSE, 250V T1A	Δ				
F701, 702	XBA2C16TBO	FUSE, 250V T1.6A	Δ				
		SWITCH(ES)					

Notes : * Capacity values are in microfarads (μF) unless specified otherwise, P=Pico-farads (pF) F=Farads (F)
 * Resistance values are in ohms, unless specified otherwise, 1K=1,000 (OHM) , 1M=1,000k(OHM)

Ref. No.	Part No.	Values & Remarks	Ref. No.	Part No.	Values & Remarks	Ref. No.	Part No.	Values & Remarks
		RESISTORS	R601	ERDS2TJ391	1/4W 390	C421	ECBT1H102KB5	50V 1000P
R223, 224	ERDS2TJ103	1/4W 10K	R602	ERDS2TJ561	1/4W 560	C501, 502	ECA1HAP3R3B	50V 3.3U
R251	ERDS2TJ222	1/4W 2.2K	R603, 604	ERDS2TJ472	1/4W 4.7K	C503, 504	ECBT1C332KR5	16V 3300P
R253, 254	ERDS2EJ121	1/4W 120	R701 Δ	ERD2FCVJ4R7T	1/4W 4.7	C505, 506	ECBT1H150J5	50V 15P
R255	ERDS2TJ154	1/4W 150K	R702 Δ	ERD25FJ2R2	1/4W 2.2	C507, 508	ECBT1C472KR5	16V 4700P
R256	ERDS2TJ105T	1/4W 1M	R703, 704	ERDS2TJ562	1/4W 5.6K	C509, 510	ECEA1HKA2R2B	50V 2.2U
R259	ERDS2TJ561	1/4W 560	R705	ERDS2TJ103	1/4W 10K	C511, 512	ECBT1C122KR5	16V 1200P
R291, 292	ERDS2TJ472	1/4W 4.7K	R706	ERDS2TJ100	1/4W 10	C513	ECA1HMA70B	50V 47U
R301, 302	ERDS2TJ222	1/4W 2.2K	R709	ERG1SJ221E	1W 220	C514	ECA2AAP100B	100V 10U
R303, 304	ERDS2TJ333	1/4W 33K	R711	ERG1SJ271E	1W 270	C515, 516	ECFRI1H04ZF	50V 0.1U
R305, 306	ERDS2TJ123	1/4W 12K	R716	ERDS2TJ392T	1/4W 3.9K	C517, 518	ECEA1HKAR33B	50V 0.33U
R307, 308	ERDS2TJ102	1/4W 1K	R717	ERDS2TJ473	1/4W 47K	C571	ECEA0JKA101B	6.3V 100U
R309-312	ERDS2EJ121	1/4W 120	R731	ERDS2TJ104	1/4W 100K	C572	ECBT1E223ZF	25V 0.022U
R331, 332	ERDS2TJ122	1/4W 1.2K	R780	ERDS2TJ822	1/4W 8.2K	C701, 702 Δ	ECA1HM222B	50V 2200U
R375	ERDS2TJ103	1/4W 10K	R781, 782	ERDS2TJ561	1/4W 560	C703, 704	ECEA1CKA330B	16V 33U
R391	ERDS2TJ473	1/4W 47K	R791	ERDS2TJ101	1/4W 100	C705, 706	ECKRI1H03ZF5	50V 0.01U
R401	ERDS2TJ332	1/4W 3.3K	R793 Δ	ERQ16NKR15E	1/6W 0.15	C707 Δ	ECA1HMA70B	50V 47U
R403	ERDS2TJ223	1/4W 22K	R801	ERDS2TJ821	1/4W 820	C710	ECBT1E103ZF	25V 0.01U
R404	ERDS2TJ122	1/4W 1.2K	R802	ERDS2TJ102	1/4W 1K	C711	ECQE1104KF3	100V 0.1U
R405	ERDS2TJ184T	1/4W 180K	R803	ERDS2TJ122	1/4W 1.2K	C712	ECBT1E223ZF	25V 0.022U
R406	ERDS2TJ102	1/4W 1K	R804	ERDS2TJ152	1/4W 1.5K	C714	ECKRI1H03ZF5	50V 0.01U
R407	ERDS2TJ104	1/4W 100K	R805	ERDS2TJ182	1/4W 1.8K	C731	ECEA1HKN010B	50V 1U
R408	ERDS2TJ473	1/4W 47K	R806	ERDS2TJ222	1/4W 2.2K	C781 Δ	RCE1AKA330BG	10V 33U
R409	ERDS2TJ332	1/4W 3.3K	R807	ERDS2TJ332	1/4W 3.3K	C799	ECBT1H104ZF5	50V 0.1U
R410	ERDS2TJ102	1/4W 1K	R850	ERDS2TJ682T	1/4W 6.8K	C905, 906	ECBT1H101KB5	50V 100P
R411	ERDS2TJ562	1/4W 5.6K			CAPACITORS	C1101, 1102	ECBT1E223ZF	25V 0.022U
R412	ERDS2TJ102	1/4W 1K				C1103-1106	ECBT1H102KB5	50V 1000P
R413	ERDS2TJ562	1/4W 5.6K	C251	ECEA0JKA221B	6.3V 220U			
R414	ERDS2TJ332	1/4W 3.3K	C301, 302	RCE1CKA100BG	16V 10U			
R415	ERDS2TJ103	1/4W 10K	C303-306	ECBT1H101KB5	50V 100P			
R420	ERDS2TJ104	1/4W 100K	C307, 308	ECEA1CKA220B	16V 22U			
R501, 502	ERDS2TJ102	1/4W 1K	C381, 382	ECBT1E103ZF	25V 0.01U			
R503-506	ERDS2TJ563	1/4W 56K	C395, 396	ECBT1E223ZF	25V 0.022U			
R507, 508	ERDS2TJ182	1/4W 1.8K	C397, 398	ECBT1E103ZF	25V 0.01U			
R509, 510	ERDS2TJ821	1/4W 820	C401	ECBT1H221KB5	50V 220P			
R511	ERDS2TJ334	1/4W 330K	C403	ECEA1HKA010B	50V 1U			
R512	ERDS2TJ154	1/4W 150K	C404	ECBT1H221KB5	50V 220P			
R513	ERDS2TJ684	1/4W 680K	C405	ECBT1H151KB5	50V 150P			
R514 Δ	ERD25FJ470	1/4W 47	C406, 407	RCE1HKA3R3BG	50V 3.3U			
R515, 516 Δ	ERDS1FVJ100T	1/2W 10	C408	ECBT1H181KB5	50V 180P			
R517, 518 Δ	ERD25FVJ100T	1/4W 10	C409	ECEA1HKA2R2B	50V 0.22U			
R519, 520	ERDS2TJ392T	1/4W 3.9K	C410	ECBT1E223ZF	25V 0.022U			
R571	ERDS2TJ823T	1/4W 82K	C411	ECBT1E103ZF	25V 0.01U			
R572	ERDS2TJ124T	1/4W 120K	C412	ECBT1E223ZF	25V 0.022U			
R573	ERDS2TJ563	1/4W 56K	C413	ECEA1HKA2R2B	50V 2.2U			
R574	ERDS2TJ564	1/4W 560K	C414	ECEA1AU331	10V 330U			
R575	ERDS2TJ223	1/4W 22K	C415	ECBT1H102KB5	50V 1000P			
			C416	ECEA1HKA010B	50V 1U			

Note: The reference number SA represent the grease and tool used for this unit.

Ref. No.	Part No.	Part Name & Description	Remarks	Ref. No.	Part No.	Part Name & Description	Remarks
		CABINET PARTS				ACCESSORIES	
1	RKM0202A-K	TOP CABINET		A1	RAK-CH204WH	REMOTE CONTROL TRANSMITTER	
2	RHD30007-K1	SCREW		A1-1	RKK0057-K	BATTERY COVER	
3	XTBS3+10JFZ1	SCREW		A2	REE0499	SPEAKER CORD (2000 mm)	
4	RFKJECA7-N	BOTTOM CHASSIS ASS'Y		A3	REX0608	FLAT CABLE (SHORT)	
4-1	RKA0011-3	FOOT		A4	REX0660	FLAT CABLE (MEDIUM)	
5	RKF0429C-K	REAR PANEL	(E, EG, EP)	A5	REX0661	FLAT CABLE (LONG)	
5	RFKHECH540EB	REAR PANEL ASS'Y	(EB)	A6	RJA0019-2K	AC MAINS LEAD	△ (SF) (E, EG, EP)
6	RKQ0089	SPACER		A6	RJA0049-K	AC MAINS LEAD	△ (EB)
7	RMC0158	HOLDER		A7	RFKSECH570EK	INSTRUCTION MANUAL ASS'Y	(E)
8	RFKGECH540EK	FRONT PANEL ASS'Y		A7	RFKSECH570EB	INSTRUCTION MANUAL ASS'Y	(EB)
9	RGLO282-Q	PANEL LIGHT		A7	RQT3481-D	INSTRUCTION MANUAL	(EG)
10	RGLO292-Q	PANEL LIGHT		A7	RQT3496-Q	INSTRUCTION MANUAL	(EP)
11	RGU1224-K	BUTTON, POWER		A8	RQA0117	WARRANTY CARD	(E, EG, EP)
12	RGU1225-K	BUTTON, OPERATION		A9	RQC80169	SERVICE CENTER LIST	(E, EG, EP)
13	RGW0207-1K	KNOB, MAIN		A10	RSA0012	AM LOOP ANTENNA	
14	RGW0235-K	KNOB, MIC		A10-1	RMNO244	ANTENNA HOLDER	
15	RHD26016	SCREW		A10-2	XTN3+12AFZ	SCREW	
16	RMNO329-J	HOLDER		A11	RSA0007	FM INDOOR ANTENNA	
17	SNE4021-1	NUT		A12	SJP9009	ATTACHMENT PLUG	(EB)
18	XTBS26+10J	SCREW				GREASE OR JIG/TOOL	
19	XTBS3+8JFZ1	SCREW					
20	XTB3+10JFZ	SCREW		SA1	RFKX0002	COMPOUND GREASE	
21	XTB3+12JFZ	SCREW					
22	XTB3+20JFZ	SCREW					
23	XTB3+8JFZ	SCREW					
24	XTW3+15T	SCREW					
25	RMNO191	HOLDER					
26	RWJ1808130XX	FLAT CABLE (8P) (W703)					
27	RWJ1812220QC	FLAT CABLE (12P) (W501)					
28	RWJ1803200QC	FLAT CABLE (3P) (W502)					
		PACKING MATERIALS					
P1	RPG3125	PACKING CASE (SYSTEM)					
P2	RPG2708	PACKING CASE (CD/TUNER)					
P3	RPG2707	PACKING CASE (DECK)					
P4	RPG2706	PACKING CASE (AMPLIFIER)					
P5	RPNO893	PAD (CD/TUNER)					
P6	RPNO892	PAD (DECK)					
P7	RPNO891	PAD (AMPLIFIER)					
P8	SPP740	PROTECTION COVER					
P9	RPF0139	PROTECTION COVER					
P10	RPQ0522	SPACER					
P11	RPQ0541	SPACER					
P12	RPQ0664	SPACER					

Cabinet Parts Location

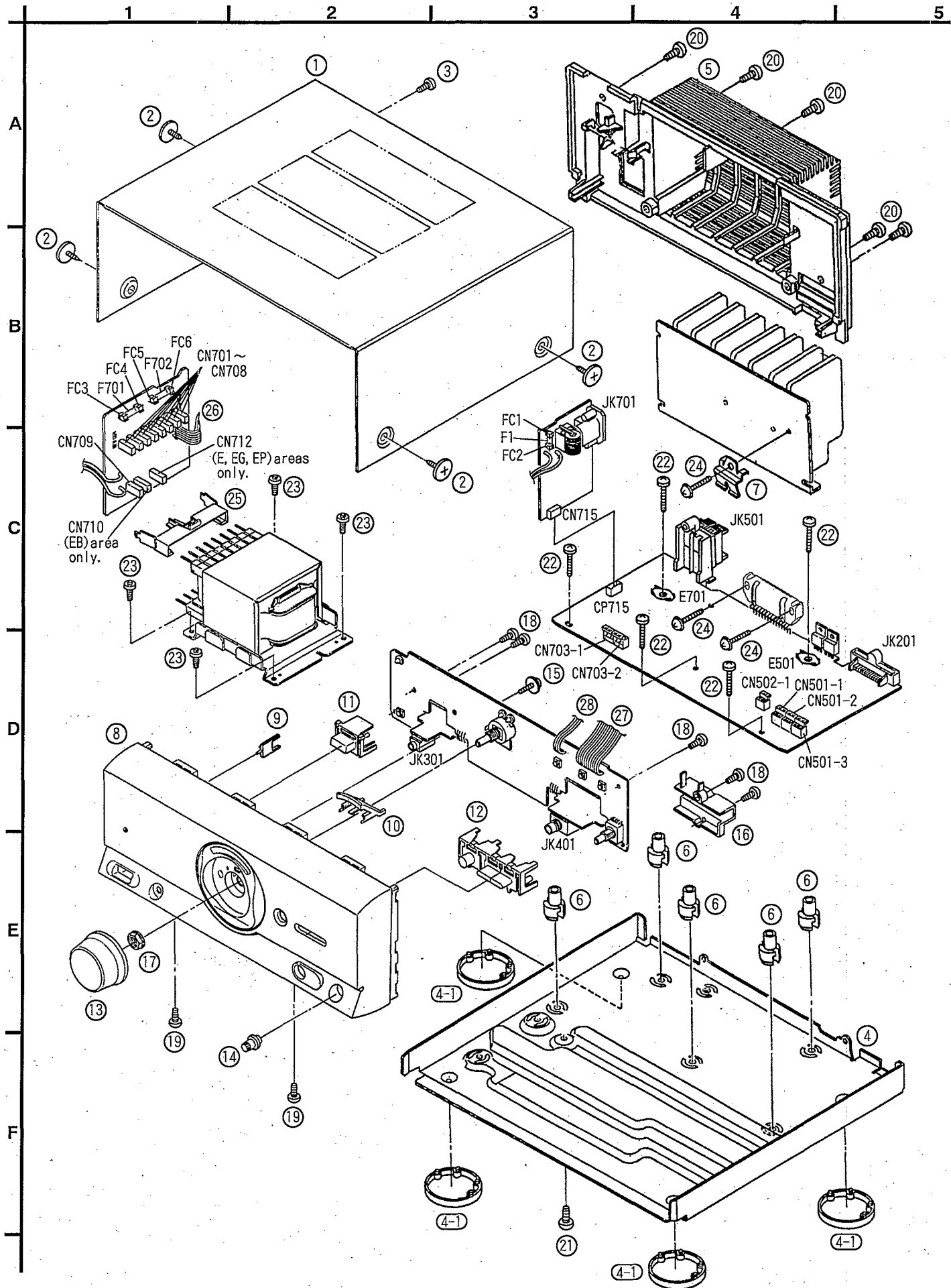

1127

■ Packaging

