

Service Manual

Amplifier

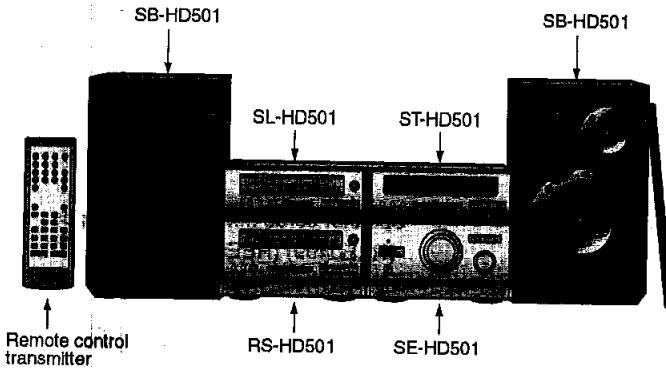

SE-HD501

Colour
 (N).....Gold Type

Areas
 E.....Europe.
 EG.....Germany and Italy, etc.
 EB.....Great Britain.
 EP.....East Europe and Russia.

System: SC-HD501

Because of unique interconnecting cables, when a compact requires service, send or bring in the entire system.

Specifications

Amplifier Section

Power output
 DIN 1 kHz, THD
 RMS 1 kHz, THD
 Total harmonic distortion
 Half power at 1
 Load impedance
 S/N: 75dB

Amplifier Section



Power output
 DIN 1 kHz, THD 1%, both channels driven : 2 X 5W (6 ohm)
 RMS 10 kHz, THD 10%, both channels driven: 2 X 8W (6 ohm)
 Load impedance: 6 ohm
 S/N: 75dB

Headphones

Jack type: 3.5mm STEREO
 Load impedance : 16-32 ohm

System/SC-HD501:

Tuner: ST-HD501, Compact Disc Player: SL-HD501, Amplifier: SE-HD501, Cassette Deck: RS-HD501, Speakers: SB-HD501 (Made in PAES.)

 KRPH	Door No. 3	 51 f
	Drop No. 0	
Customer: TECHNICA42		
Load: SPOWE1		
Model: AD9902014C2	Qty: 1	
Assembled at: 60	05/07/00	

: 73W
 on Normal: 9W
 Eco: 0.8W
 30-240V, AC 50Hz
 areas]: 230V, AC 50Hz
 D): 196 x 104 x 270 mm

1. Specifications are subject to change without notice.
2. Dimensions and Weight are approximate.
3. Total harmonic distortion is measured by the digital spectrum analyzer.

WARNING

This service information is designed for experienced repair technicians only and is not designed for use by the general public. It does not contain warnings or cautions to advise non-technical individuals of potential dangers in attempting to service a product. Products powered by electricity should be serviced or repaired only by experienced professional technicians. Any attempt to service or repair the product or products dealt with in this service information by anyone else could result in serious injury or death.

CONTENTS

	Page		Page
1 Accessories	2	7.2. Schematic Diagram Notes	13
2 Before Repair and Adjustment	2	8 Schematic Diagram	14
3 Caution for AC Main Lead	3	9 Printed Circuit Board Diagram	17
4 Operating Instructions	4	10 Block Diagram	20
5 Operation Checks and Component Replacement Procedures	9	11 Wiring Connection Diagram	21
6 Power Source ON/OFF and Signal Check	12	12 Replacement Parts List	22
7 Schematic Diagram Notes	12	13 Cabinet Parts Location	25
7.1. Type Illustration of IC's, Transistors and Diodes	12	14 Packaging	26

1 Accessories

- AC power supply cord 1 pc.
For (EB) area: (RJA0053-2X)
- For (E, EG, EP) areas: (RJA0019-X)

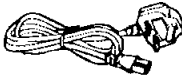

- Remote control transmitter 1 pc.
(RAK-HDA07WH)

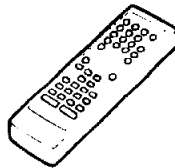

- Speaker cords 4 pcs.
(REE0499) (REE0853)

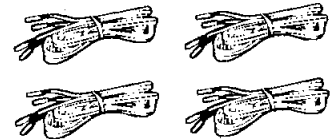

- Remote control batteries 2 pcs.
[[R6/LR6 (AA, UM-3)]]
- Note:** These are available on sales route.

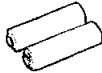

- AM loop antenna set (RSA0021)
- AM loop antenna 1 pc.
- Antenna holder with stand 1 pc.

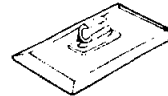

- Antenna holder 1 pc.
- Screw 1 pc.



- FM indoor antenna 1 pc.
(RSA0007)



- Antenna plug adaptor 1 pc.
For (EB) area only:
(SJP9009)



2 Before Repair and Adjustment

1. Turn off the power supply. Using a 10Ω , 10W resistor, connect both ends of power supply capacitors (C102-105, 127) in order to discharge the voltage.
2. Before turning the power supply on, after completion of repair, slowly apply the primary voltage by using a power supply voltage controller to make sure that the consumed current at 50/60 Hz in NO SIGNAL mode should be shown below with respect to supply voltage 230 V/240 V.

Area	(E) (EG) (EP)		(EB)	
	AC 230V		AC 240V	
Power supply voltage	50 Hz	60-180 mA	50 Hz	55-175 mA
Consumed current 50 Hz				

3 Caution for AC Main Lead (For United Kingdom)

("EB" area code model only)

For your safety, please read the following text carefully.

This appliance is supplied with a moulded three pin mains plug for your safety and convenience.

A 5-ampere fuse is fitted in this plug.

Should the fuse need to be replaced please ensure that the replacement fuse has a rating of 5-ampere and that it is approved by ASTA or BSI to BS1362.

Check for the ASTA mark  or the BSI mark  on the body of the fuse.

If the plug contains a removable fuse cover you must ensure that it is refitted when the fuse is replaced.

If you lose the fuse cover the plug must not be used until a replacement cover is obtained.

A replacement fuse cover can be purchased from your local dealer.

CAUTION!

IF THE FITTED MOULDED PLUG IS UNSUITABLE FOR THE SOCKET OUTLET IN YOUR HOME THEN THE FUSE SHOULD BE REMOVED AND THE PLUG CUT OFF AND DISPOSED OF SAFELY.

THERE IS A DANGER OF SEVERE ELECTRICAL SHOCK IF THE CUT OFF PLUG IS INSERTED INTO ANY 13-AMPERE SOCKET.

If a new plug is to be fitted please observe the wiring code as shown below.

If in any doubt please consult a qualified electrician.

IMPORTANT

The wires in this mains lead are coloured in accordance with the following code:

Blue: Neutral, Brown: Live.

As these colours may not correspond with the coloured markings identifying the terminals in your plug, proceed as follows:

The wire which is coloured Blue must be connected to the terminal which is marked with the letter N or coloured Black or Blue.

The wire which is coloured Brown must be connected to the terminal which is marked with the letter L or coloured Brown or Red.

WARNING: DO NOT CONNECT EITHER WIRE TO THE EARTH TERMINAL WHICH IS MARKED WITH THE LETTER E, BY THE EARTH SYMBOL  OR COLOURED GREEN OR GREEN/YELLOW.

THIS PLUG IS NOT WATERPROOF & KEEP DRY.

Before use

Remove the connector cover.

How to replace the fuse

The location of the fuse differ according to the type of AC mains plug (figures A and B). Confirm the AC mains plug fitted and follow the instructions below. Illustrations may differ from actual AC mains plug.

1. Open the fuse cover with a screwdriver.

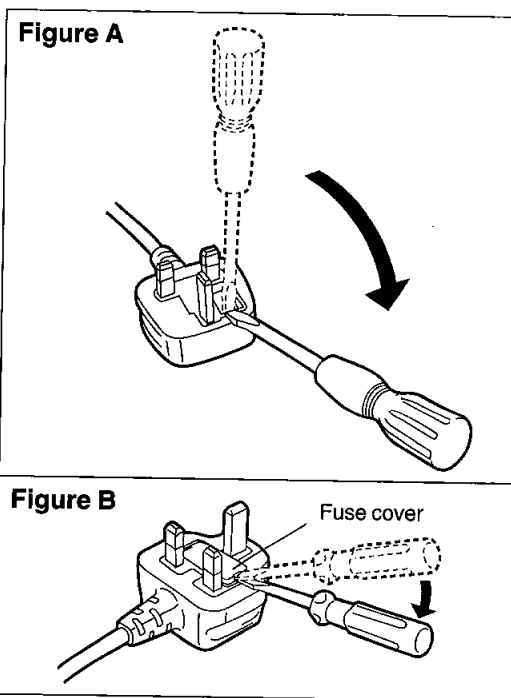

2. Replace the fuse and close or attach the fuse cover.

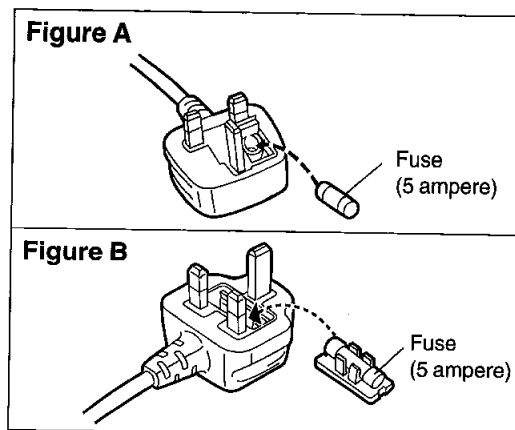

4 Operating Instructions

■ Front Panel Controls

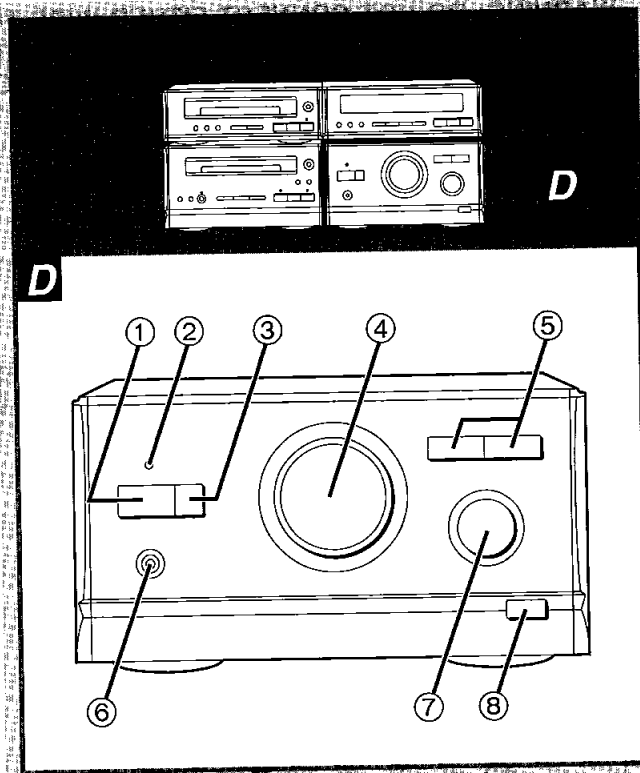

Amplifier section

- ① **Standby/on switch (⏻/⏻)**
Press to switch the unit from on to standby mode or vice versa. In standby mode, the unit is still consuming a small amount of power.
- ② **Standby indicator**
When the unit is connected to the AC mains supply, this indicator lights up in standby mode and goes out when the unit is turned on.
- ③ **Eco mode button (ECO)**
- ④ **Volume control (VOLUME)**
- ⑤ **Source input select buttons (INPUT SELECTOR \vee , \wedge)**
- ⑥ **Headphones jack (PHONES)**
- ⑦ **Fine tweeter control (FINE TWEETER CONTROL)**
- ⑧ **Bass button (BLFS)**

Remote control

Buttons such as ① function the same as the buttons on the main unit.

- ⑨ **Sleep timer button (SLEEP)**
- ⑩ **Numeric buttons**
- ⑪ **Program button (PROGRAM)**
- ⑫ **Random button (RANDOM)**
- ⑬ **Input selection buttons (CD, TAPE, EXT/MD, TUNER)**
- ⑭ **CD/tape stop button (■)**
- ⑮ **Tape reverse playback/CD pause button (◀/||)**
- ⑯ **Muting button (MUTING)**
- ⑰ **CD skip/search, tape fast forward/rewind buttons (◀◀/◀, ▶▶/▶)**
- ⑱ **Cancel button (CANCEL)**
- ⑲ **Repeat button (REPEAT)**
- ⑳ **CD play/tape forward playback button (▶)**
- ㉑ **Tuning buttons (TUNE \wedge , TUNE \vee)**

Minidisc deck operations (when connected to a minidisc deck SJ-HD501 (sold separately)) ㉑

- A **Stop button (■)**
- B **Pause button (||)**
- C **Play button (▶)**
- D **Skip, fast forward/rewind buttons (◀◀/◀, ▶▶/▶)**

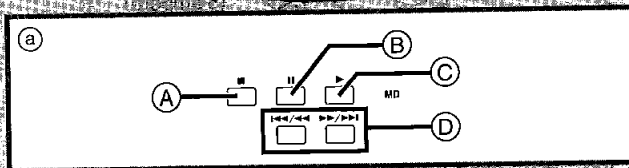
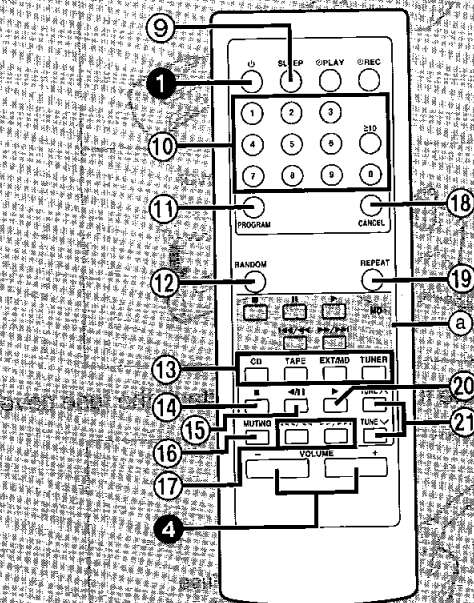

■ Installation

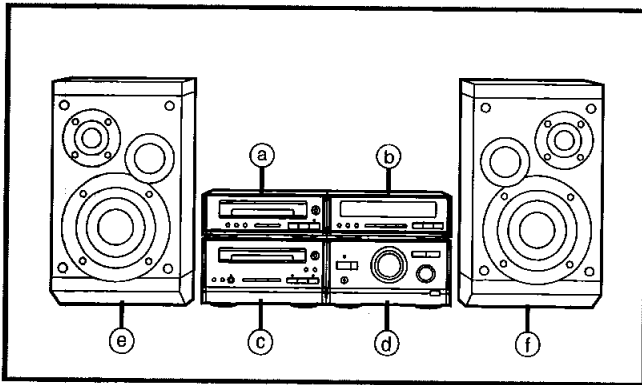

- Ⓐ CD player (SL-HD501)
- Ⓑ Tuner (ST-HD501)
- Ⓒ Cassette deck (RS-HD501)
- Ⓓ Amplifier (SE-HD501)
- Ⓔ Left speaker (SB-HD501)
- Ⓕ Right speaker (SB-HD501)

Caution

Use the speakers only with the recommended system. Failure to do so may lead to damage to the amplifier and/or the speaker, and may result in the risk of fire. Consult a qualified service person if damage has occurred or if you experience a sudden change in performance.

Note

- Do not put the CD player on the amplifier. The CDs can become hot and damaged.

■ Changing the Tone

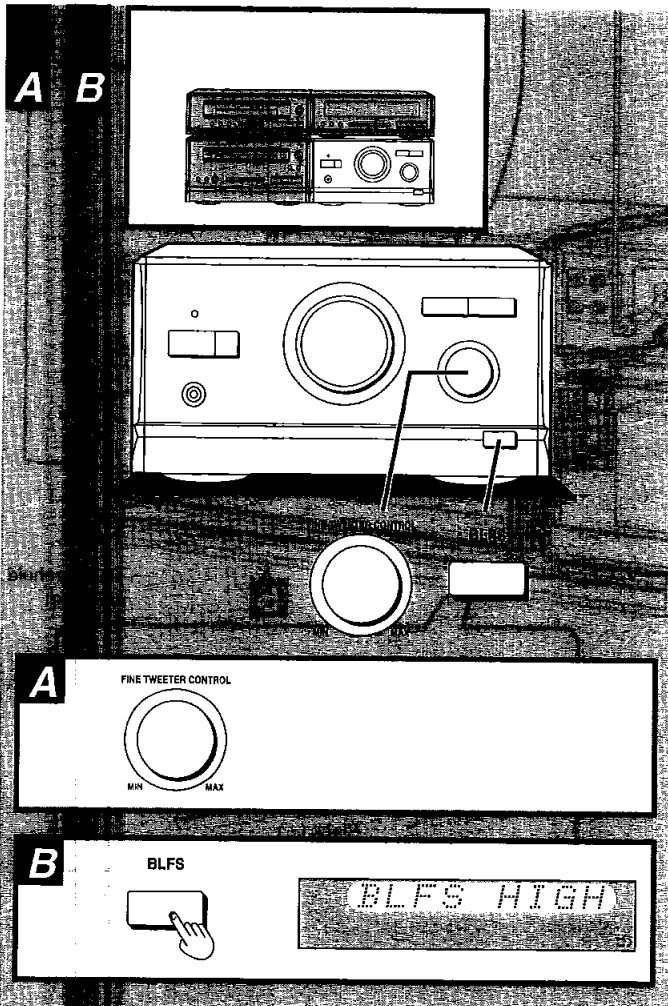

Adjusting the treble range **A**

This unit separates the tweeter and woofer so fine adjustments to the treble range can be made.

Turn [FINE TWEETER CONTROL] to adjust to the preferred sound quality.

Set it to MAX when you want to emphasize the treble range, or to MIN when you want to reduce it.

Note

This effect is not discernible when using headphones.

Emphasizing low frequency sounds **B**

BLFS (Brisk Low Frequency Sound)

This effect increases the bass range to give music more power without interfering with the vocal range.

Press [BLFS].

Each time you press the button;
BLFS HIGH → BLFS LOW → BLFS OFF (FLAT)

To cancel:

Press [BLFS] to select "BLFS OFF". ("FLAT" will light.)

■ Connections

Connect the AC mains lead after you have connected all other cables.

To prepare the AM loop antenna wire and speaker cords, twist the vinyl cover tip and pull off.

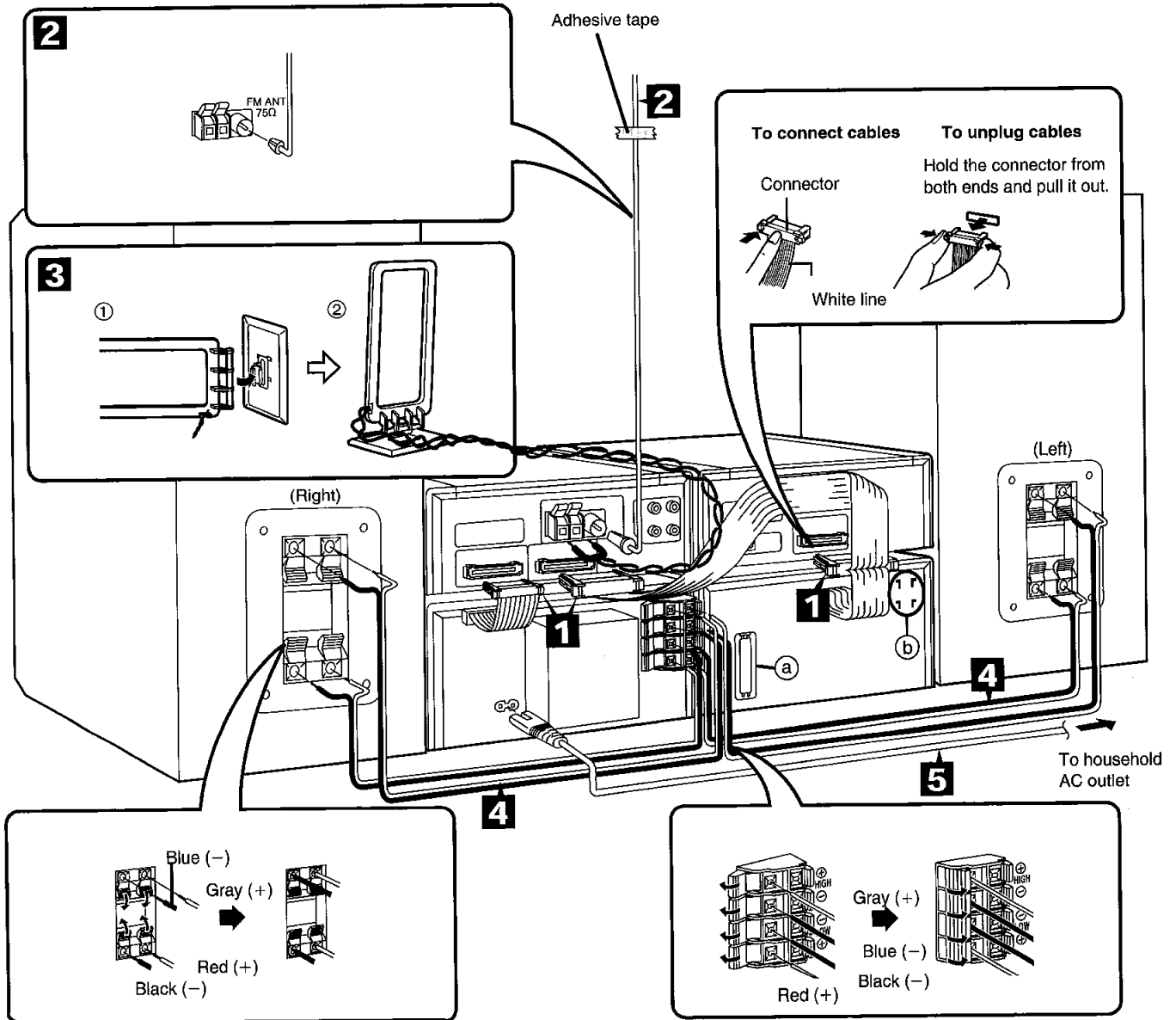
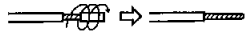

Before connection

Disconnect the flat cable on the cassette deck. (a)

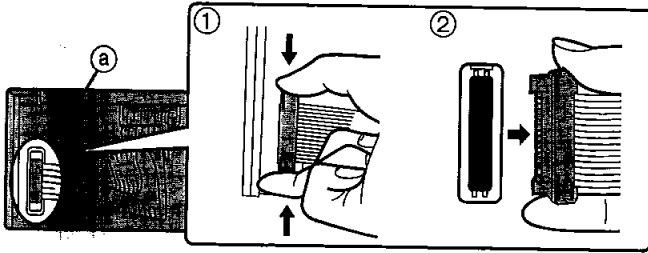
**1 Connect the flat cables.**

Connect the flat cables to the terminals on each unit.

Note

Do not connect or disconnect the flat cables while the unit is on.

After connection:

Keep cables as flat against the back of the unit as possible.

2 Connect the FM indoor antenna.

Tap the antenna to a wall or column where radio signals are received with the least amount of interference.

Note

When you cannot get good reception with this FM indoor antenna, we recommend you install an FM outdoor antenna (not included).

3 Connect the AM loop antenna.

You can also install the AM loop antenna on the rear of the cassette deck, wall or pillars.

In this case, be sure to use the antenna holder with the hole.

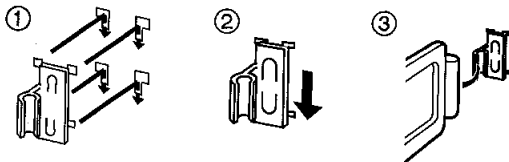
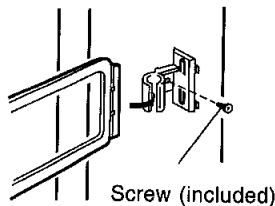
•To install on the cassette deck rear (b)**•To install on walls or pillars****Note**

Minimize noise by bundling the cord with tape to keep it away from the flat cables.

4 Connect the right (R) and left (L) speaker cables.

Connect the speaker cables to the terminal levers of the same color.

Use only the supplied speakers.

The combination of the main unit and front speakers provide the best sound. Using other speakers can damage the unit and sound quality will be negatively effected.

Note

- To prevent damage to circuitry, never short-circuit positive (+) and negative (-) speaker wires.
- Be sure to connect only positive (red or gray) wires to positive (+) terminals and negative (black or blue) wires to negative (-) terminals.

(United Kingdom only)

BE SURE TO READ THE CAUTION FOR AC MAINS LEAD BEFORE PROCEEDING TO STEP 5.

5 Connect the AC mains lead.**Insertion of Connector**

Even when the connector is perfectly inserted, depending on the type of inlet used, the front part of the connector may jut out as shown in the drawing.

However there is no problem using the unit.

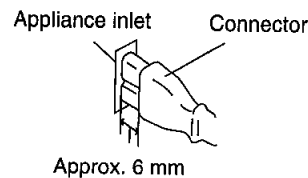
**For your reference:**

Information you enter into the unit's memory, except for the time, remains intact for up to two weeks after the mains lead is disconnected.

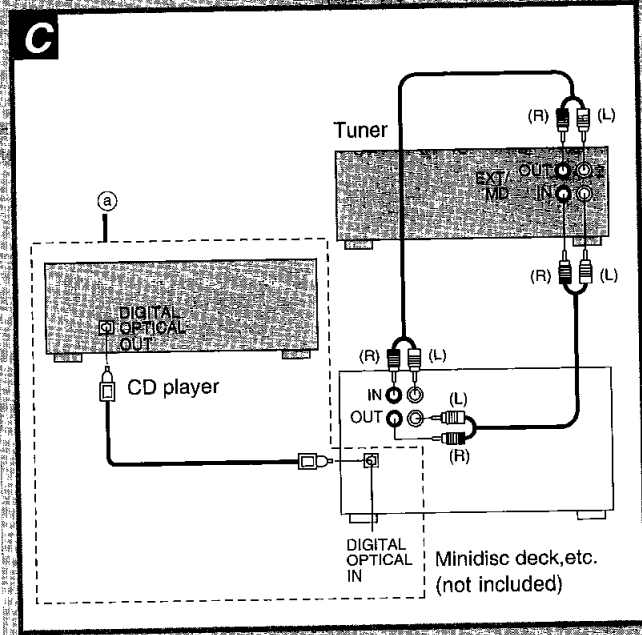
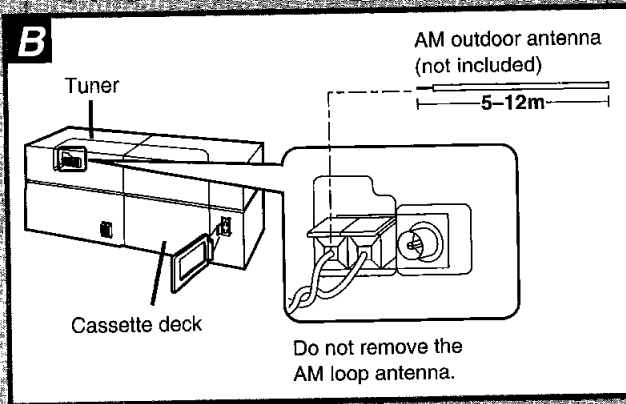
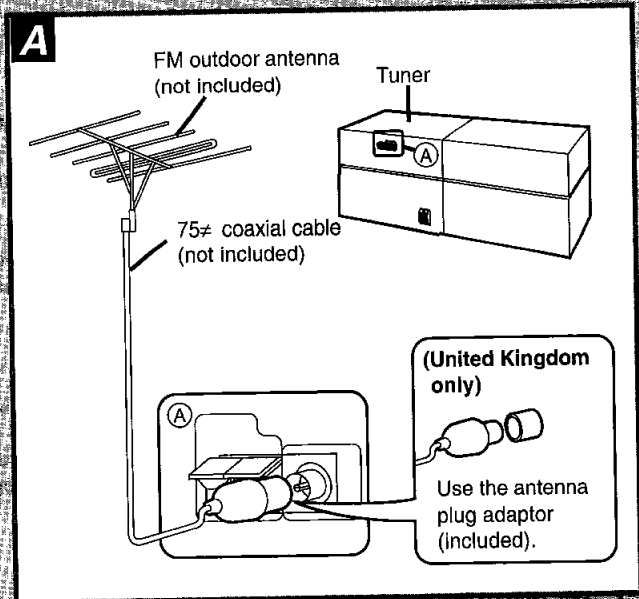

Optional antenna connections

You may need an outdoor antenna if you use this system in a mountainous region or inside a reinforced-concrete building, etc.

FM outdoor antenna (not included) A

Note

An outdoor antenna should be installed by a competent technician only.

AM outdoor antenna (not included) B

Connect the outdoor antenna without removing the AM loop antenna. Run 5 to 12 m of vinyl-covered wire horizontally along a window or other convenient location.

Note

When the unit is not in use, disconnect the outdoor antenna to prevent possible damage that may be caused by lightning. Never use an outdoor antenna during an electrical storm.

Connecting a minidisc deck, etc. C

- Make sure that the power supply for all components has been turned off before making any connections.
- For details, refer to the operating instructions of the external unit which is to be connected.
- All peripheral components and cables sold separately.

Stereo connection cable



Connections to "DIGITAL OPTICAL OUT" terminal: a

Before using this terminal, take out the dust protection cap. Connect an optical-fiber cable to the optical input terminal of the minidisc deck (not included).

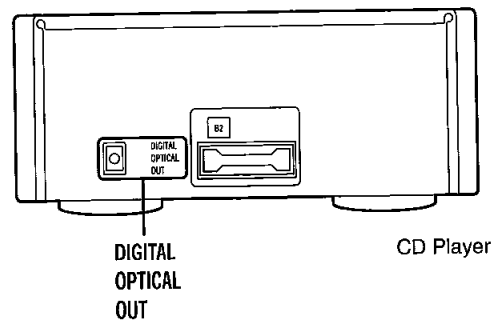

5 Operation Checks and Component Replacement Procedures

- NOTE**
1. This section describes procedures for checking the operation of the major printed circuit boards and replacing the main components.
 2. For reassembly after operation checks or replacement, reverse the respective procedures. Special reassembly procedures are described only when required.
 3. Select item from the following index when checks or replacement are required.

The fuse P.C.B. located on main P.C.B. carries the high current of primary side. Never touch the fuse P.C.B. to prevent from electric shock or breaking when turning on power. In the event of turning on power when the fuse P.C.B. is free from holder, it must be wrapped with cloth (like as insulation material) for insulation.

● Contents

■ Checking Procedures for each P.C.B.

1. Checking for the AC IN P.C.B. and relay P.C.B..
2. Checking for the operation P.C.B..
3. Checking for the main P.C.B..

■ Main Component Replacement Procedures

1. Replacement for the power IC.

■ Checking Procedures for each P.C.B.

1. Checking for the AC IN P.C.B. and relay P.C.B.

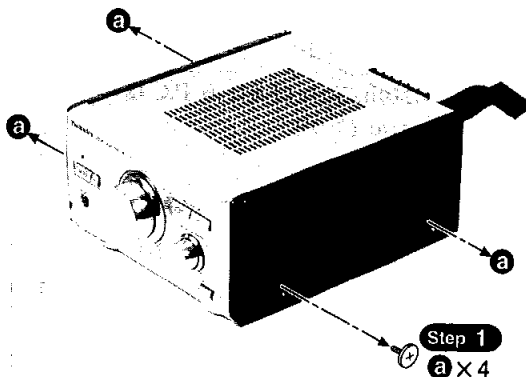

Step 2

Remove the side panel (L), (R).

(Spread the lower part of the side panels in the direction of arrow ① to release the ribs, and then lift to remove the side panels in the direction of arrow ②.)

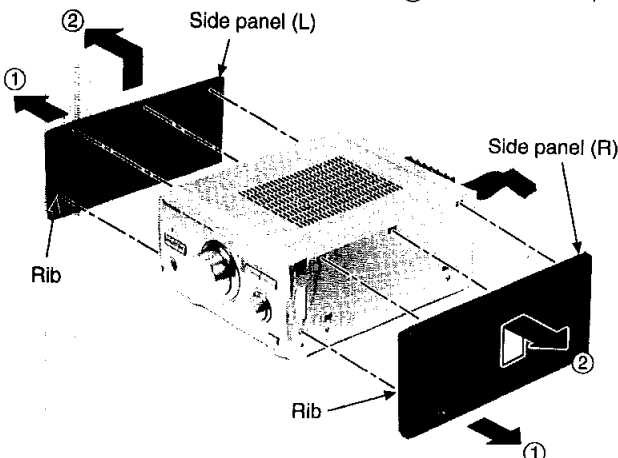

Step 4

Remove the cabinet.

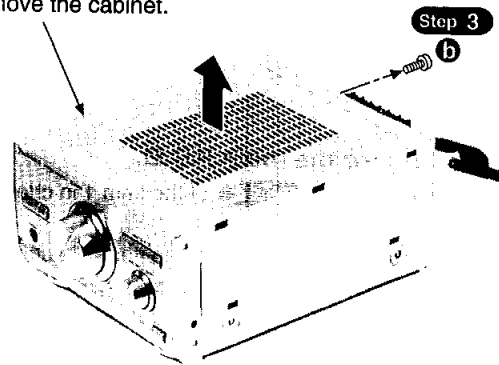

• Check the AC IN P.C.B. and relay P.C.B. as shown below.

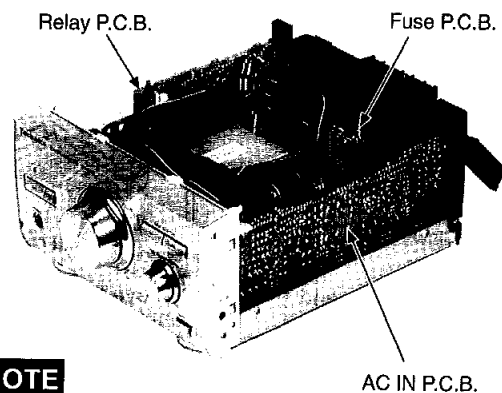

NOTE

Never touch the fuse P.C.B. with finger.

2. Checking for the operation P.C.B.

- Follow the **Step 1** ~ **Step 4** of the item 1 in checking procedure for each P.C.B..

Front panel ass'y

Claw

a

Step 1 a × 2

Step 2

Release the 2 claws, and then remove the front panel ass'y.

- Check the operation P.C.B. as shown below.

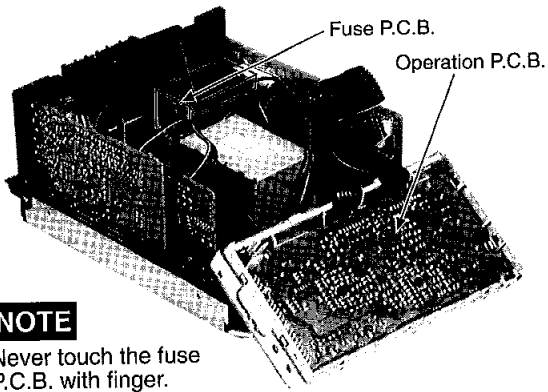

NOTE

Never touch the fuse P.C.B. with finger.

3. Checking for the main P.C.B.

- Follow the **Step 1** ~ **Step 4** of the item 1 in checking procedure for each P.C.B..
- Follow the **Step 1**, **Step 2** of the item 2 in checking procedure for each P.C.B..

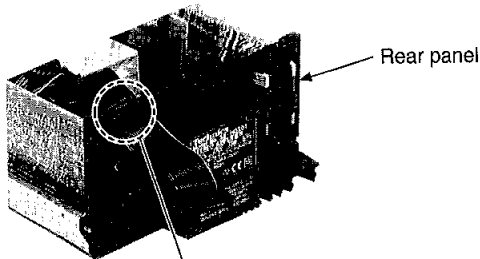

Claws

Holder

Step 1

Release the 4 claws, and then remove the holder.

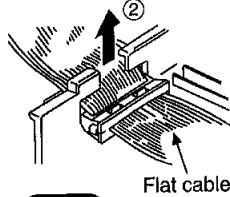

Step 2

Remove the flat cable from rear panel.

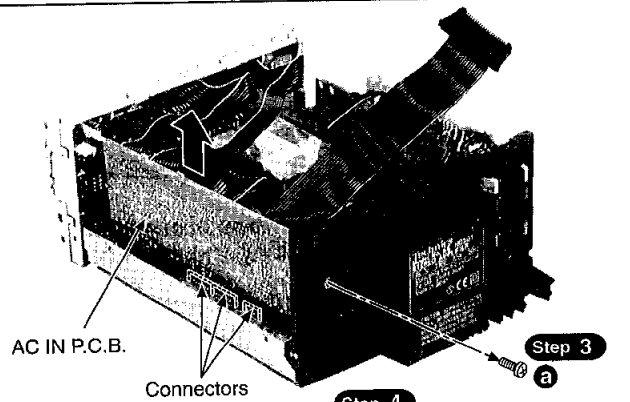

Step 3

a

Step 4

Remove the AC IN P.C.B. upward with care to prevent damage to the connectors.

Step 5

b × 3

Step 7

Release the 2 claws, and then remove the rear panel.

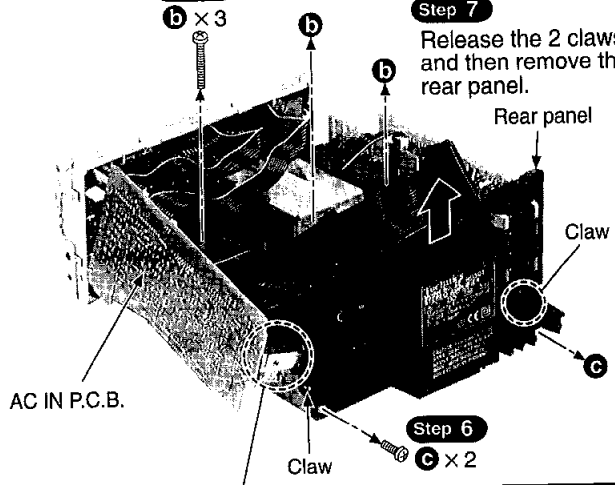

AC IN P.C.B.

Claw

Step 6

c × 2

Notice for installation of AC IN P.C.B.

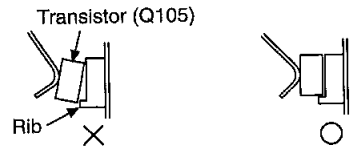

- Use care that the transistor (Q105) is not located on the rib as shown above.
- Apply the compound grease (No. RFX0002 or equivalent material) on the back side of transistor (Q105).
- Use care to prevent applying the grease on the lead wire or other parts.

Step 8

Reinstall the AC IN P.C.B. to the main P.C.B..

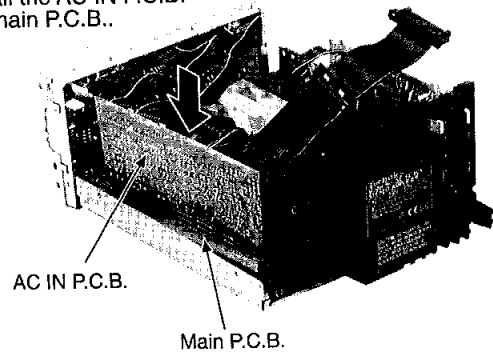

- Check the main P.C.B. as shown below.

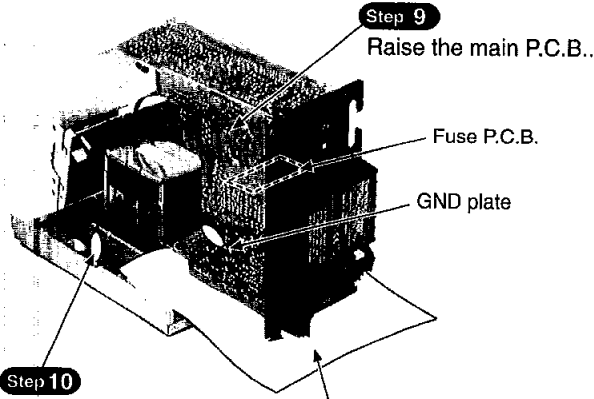

NOTE

Insulate main P.C.B. with insulation material to avoid short-circuit.

NOTE

1. Never touch the fuse P.C.B. with finger.
2. Insulate the fuse P.C.B. with cloth (like as insulation material) when removing it.

■ Main Component Replacement Procedures

1. Replacement for the power IC

- Follow the **Step 1** ~ **Step 4** of the item 1 in checking procedure for each P.C.B..
- Follow the **Step 1** , **Step 2** of the item 2 in checking procedure for each P.C.B..
- Follow the **Step 1** ~ **Step 4** of the item 3 in checking procedure for each P.C.B..

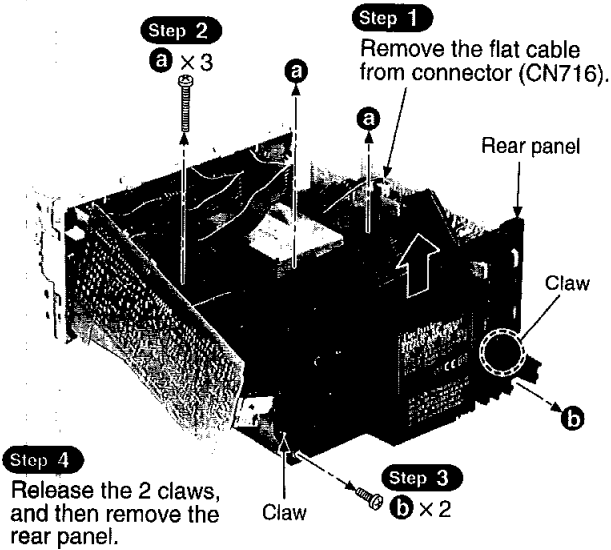

Step 7
Lift up the relay P.C.B..

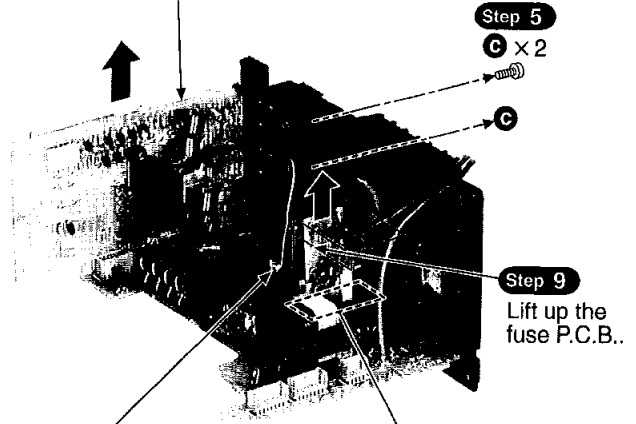

Step 6
Remove the flat cable from connector (CP701).

Step 8
Release the claw. (2 points)

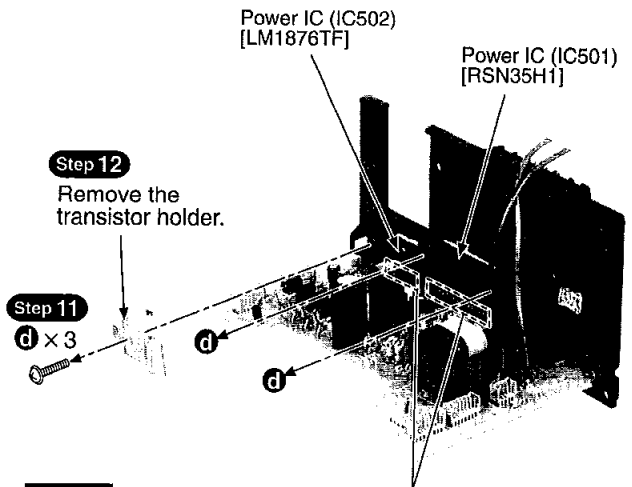
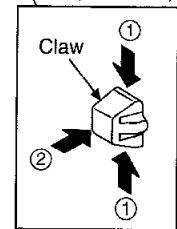

NOTE

When mounting the power IC apply silicone compound (RFKX0002) to the rear side of power IC.

Step 10
Unsolder the terminals of power IC.

6 Power Source ON/OFF and Signal Check

To operate this unit SE-HD501 normally, it is necessary for connecting with the unit ST-HD501.

When operating the unit SE-HD501, be sure to connect the unit ST-HD501 with included connection cable.

1. Connect with the Tuner (ST-HD501). (As shown in Fig. 1)
2. Connect the AC mains lead to Amplifier (SE-HD501). (As shown in Fig. 1)
3. Connect the speakers to speaker terminal. (As shown in

Fig. 1)

4. Turn on the power of the Amplifier (SE-HD501).
5. Press INPUT SELECTOR to select the external source (EXT) of the Amplifier (SE-HD501).
6. Input a sound signal to external input terminal of Tuner (ST-HD501), and confirm to be outputted from the speaker. (Both "High" and "Low".)

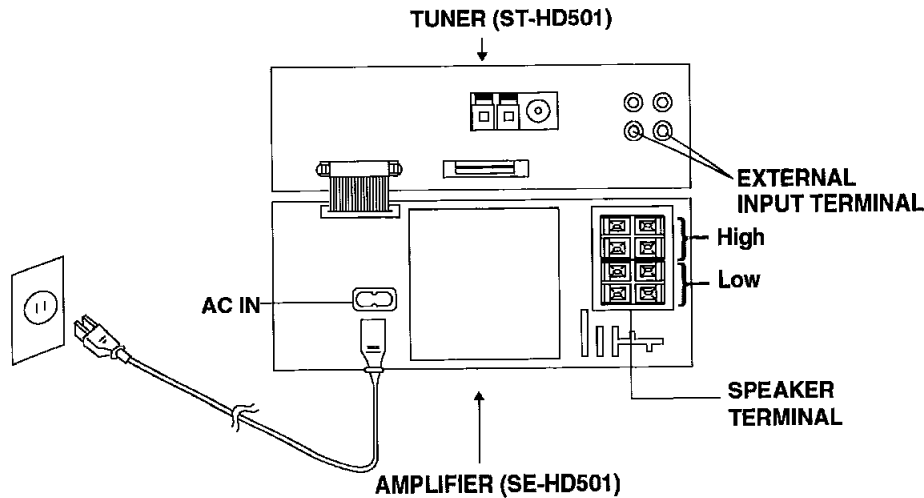

Fig. 1

7 Schematic Diagram Notes



7.1. Type Illustration of IC's, Transistors and Diodes

M5218AFPE3 	RSN35H1 	LM1876TF 	 2SA1309ATA 2SC3311ATA UN4115TA	2SB621AQRSTA
2SC3940AQSTA 	2SD2374PQAU 	2SD2144STA 	MA165TA 	MA4051MTA MA4062MTA
 MA4075MTA MA4110MTA MA4120MTA MA4150MTA MA4160MTA MA4240MTA	MA719TA 	1N5402BF RL1N4003N02 	SLR-325VC 	

7.2. Schematic Diagram Notes

- This schematic diagram may be modified at any time with the development of new technology.

Notes:

- **S301:** Power "STANDBY  / ON" switch in "OFF" position.
- **S302:** Eco mode switch in "OFF" position.
- **S303:** Source input select control () switch.
- **S304:** Source input select control () switch .
- **S305:** Bass (BLFS) switch in "OFF" position.
- **VR301:** Main control V.R.
- **VR401:** Fine tweeter control V.R.
- Indicated voltage values are the standard values for the unit measured by the DC electronic circuit tester (high-impedance)with the chassis taken as standard. Therefore, there may exist some errors in the voltage values, depending on the internal impedance of the DC circuit tester.

No mark: Power ON

- Important safety notice:

Components identified by  mark have special characteristics important for safety.

Furthemore, special parts which have purposes of fire-retardant (resistors), high-quality sound (capacitors), low-noise (resistors), etc. are used.

When replacing any of components, be sure to use only manufacturer's specified parts shown in the parts list.

- **Caution!**

IC and LSI are sensitive to static electricity.

Secondary trouble can be prevented by taking care during repair.

Cover the parts boxes made of plastics with aluminum foil.

Ground the soldering iron.

Put a conductive mat on the work table.

Do not touch the legs of IC or LSI with the fingers directly.

- **Voltage and signal line**

 : Positive voltage line

 : Negative voltage line

 : Source signal line

8 Schematic Diagram

SCHEMATIC DIAGRAM-1

A POWER SUPPLY CIRCUIT

→ : POSITIVE VOLTAGE LINE
 - - - - - : NEGATIVE VOLTAGE LINE
 ⇨ : SOURCE SIGNAL LINE

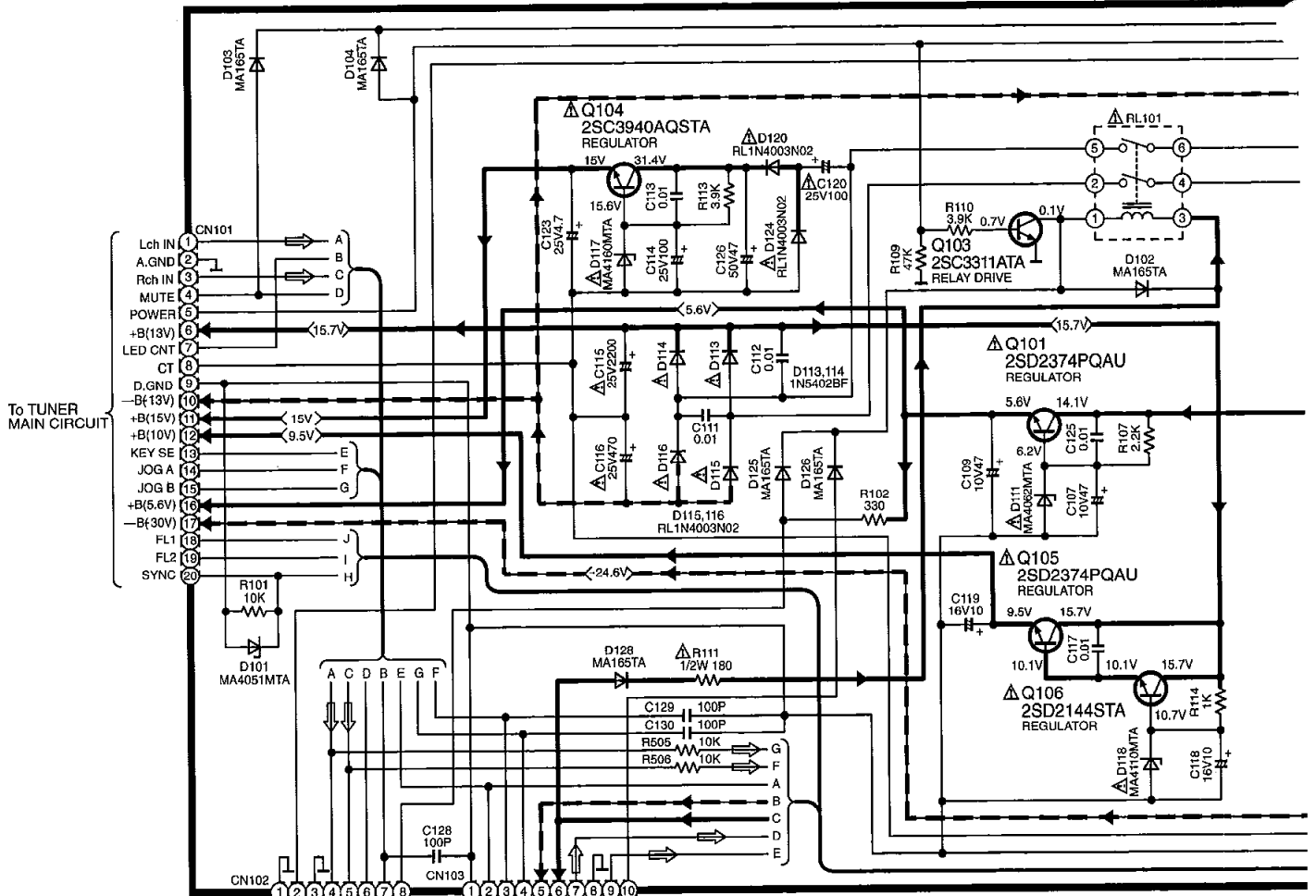

B OPERATION CIRCUIT

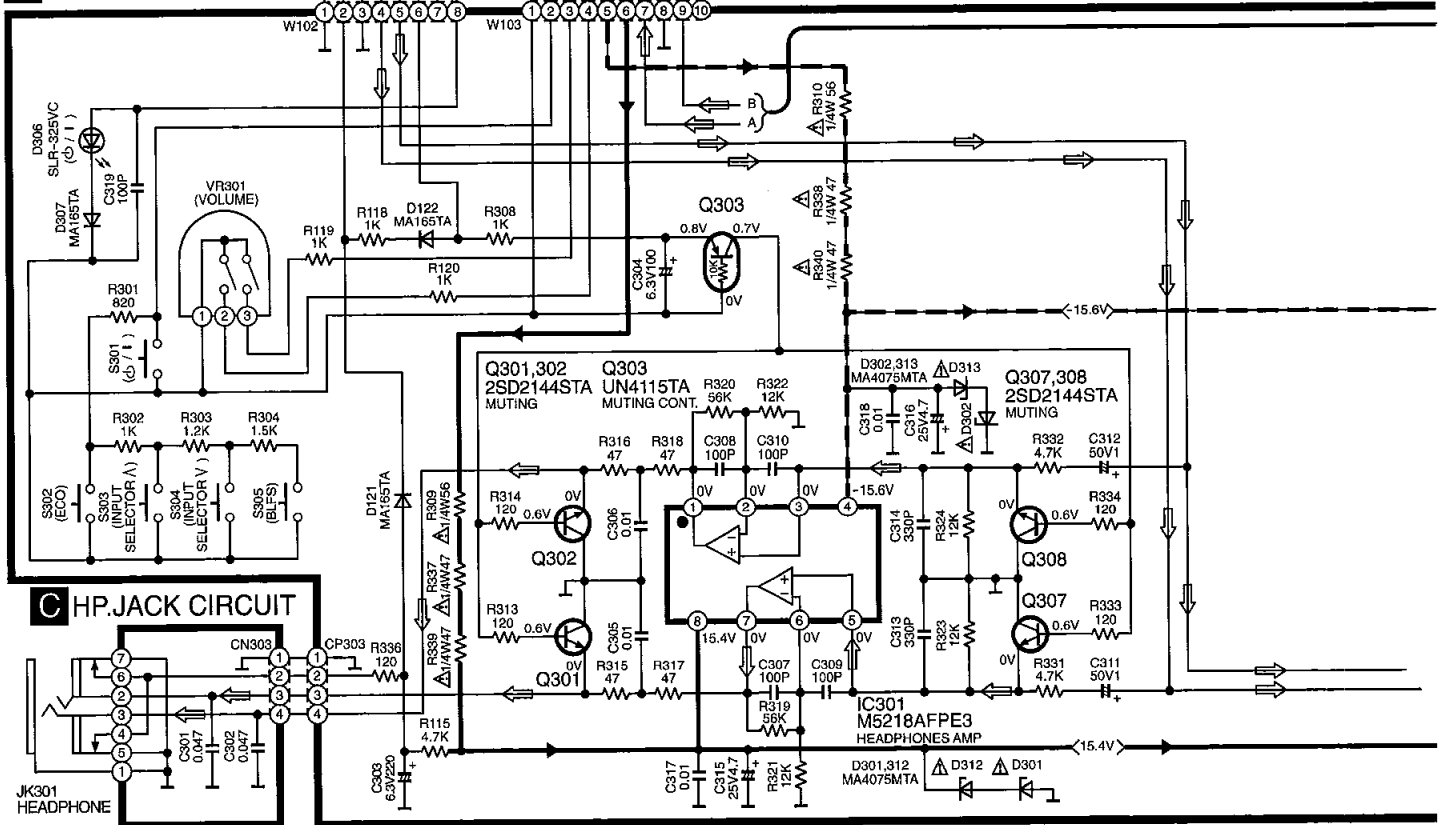

C HP.JACK CIRCUIT

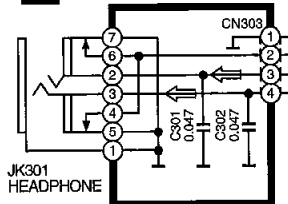

SCHEMATIC DIAGRAM-2

→ : POSITIVE VOLTAGE LINE
- - - : NEGATIVE VOLTAGE LINE
⇨ : SOURCE SIGNAL LINE

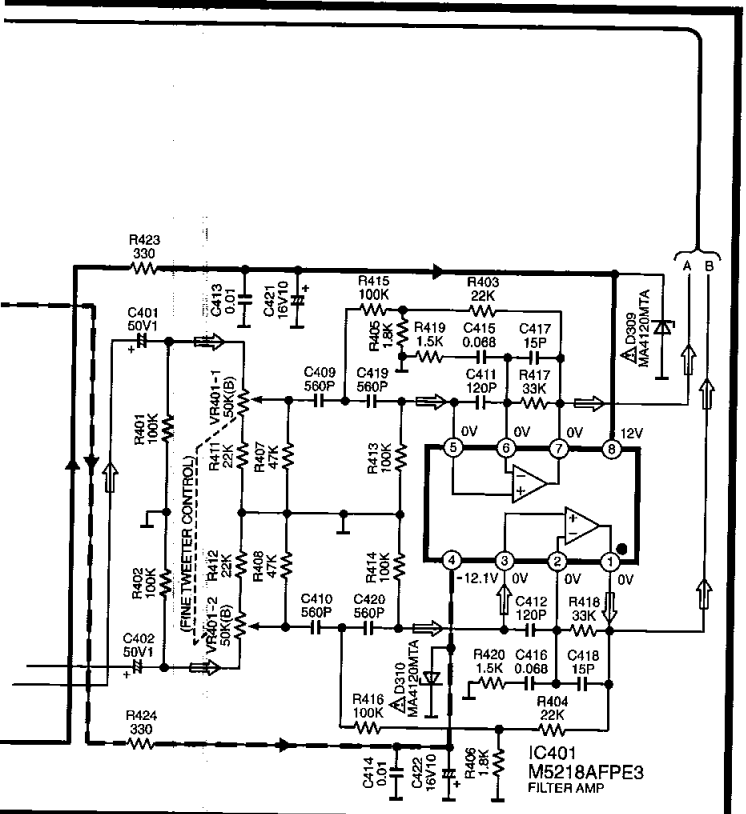
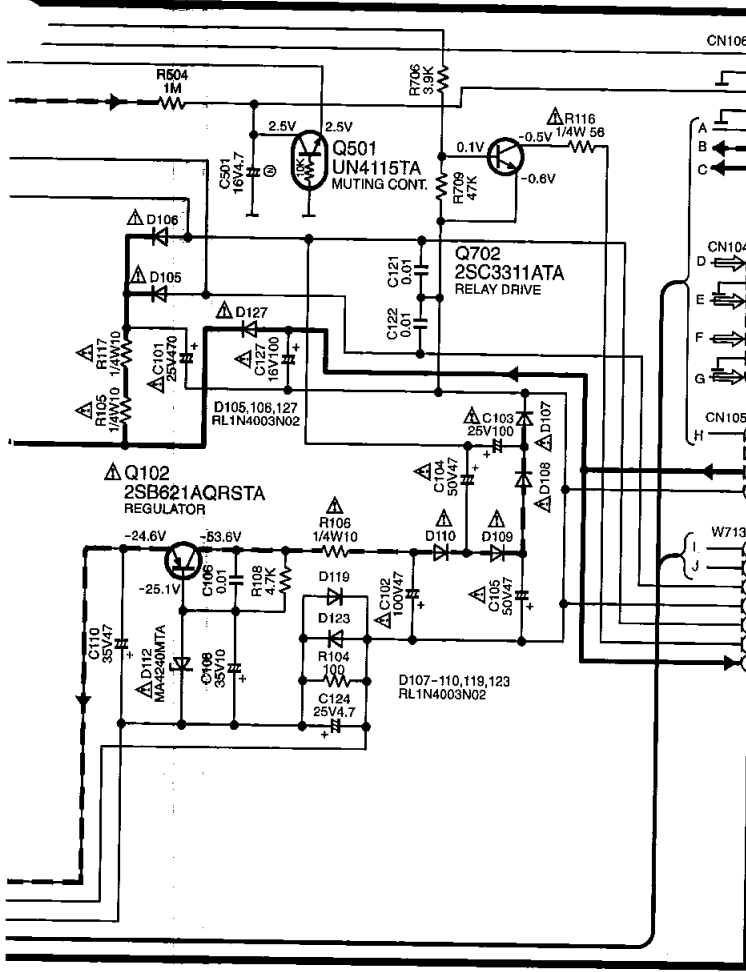

F MAIN CIRCUIT

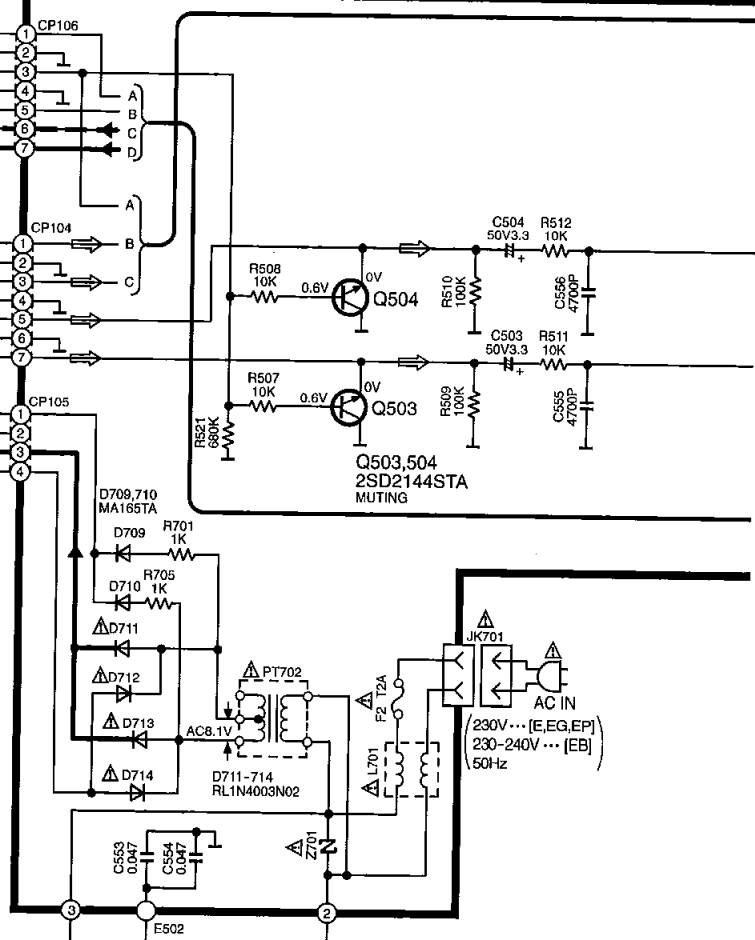

D FUSE CIRCUIT

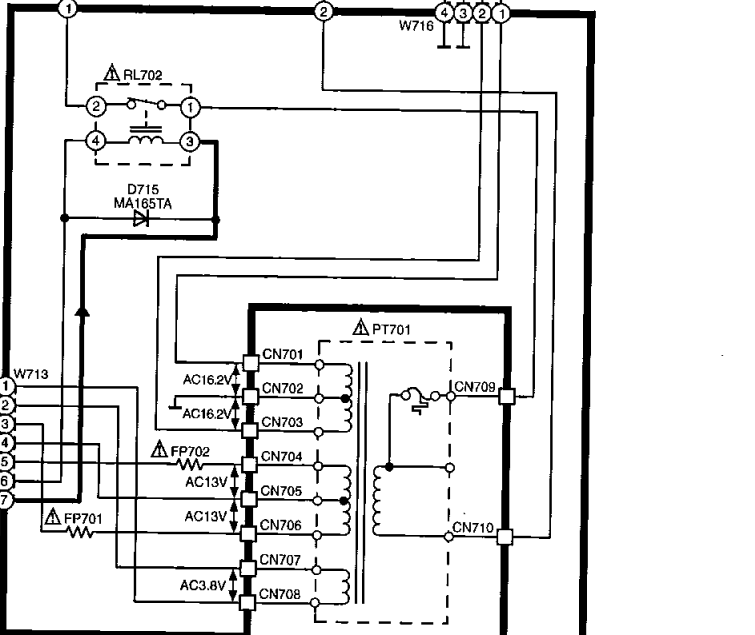
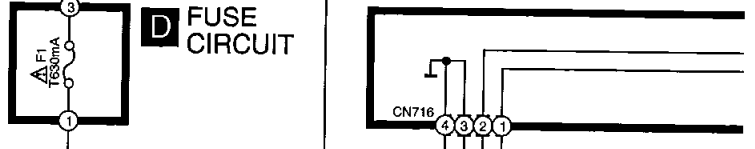

E POWER TRANSFORMER CIRCUIT

SCHEMATIC DIAGRAM-3

→ : POSITIVE VOLTAGE LINE - - - : NEGATIVE VOLTAGE LINE ⇨ : SOURCE SIGNAL LINE

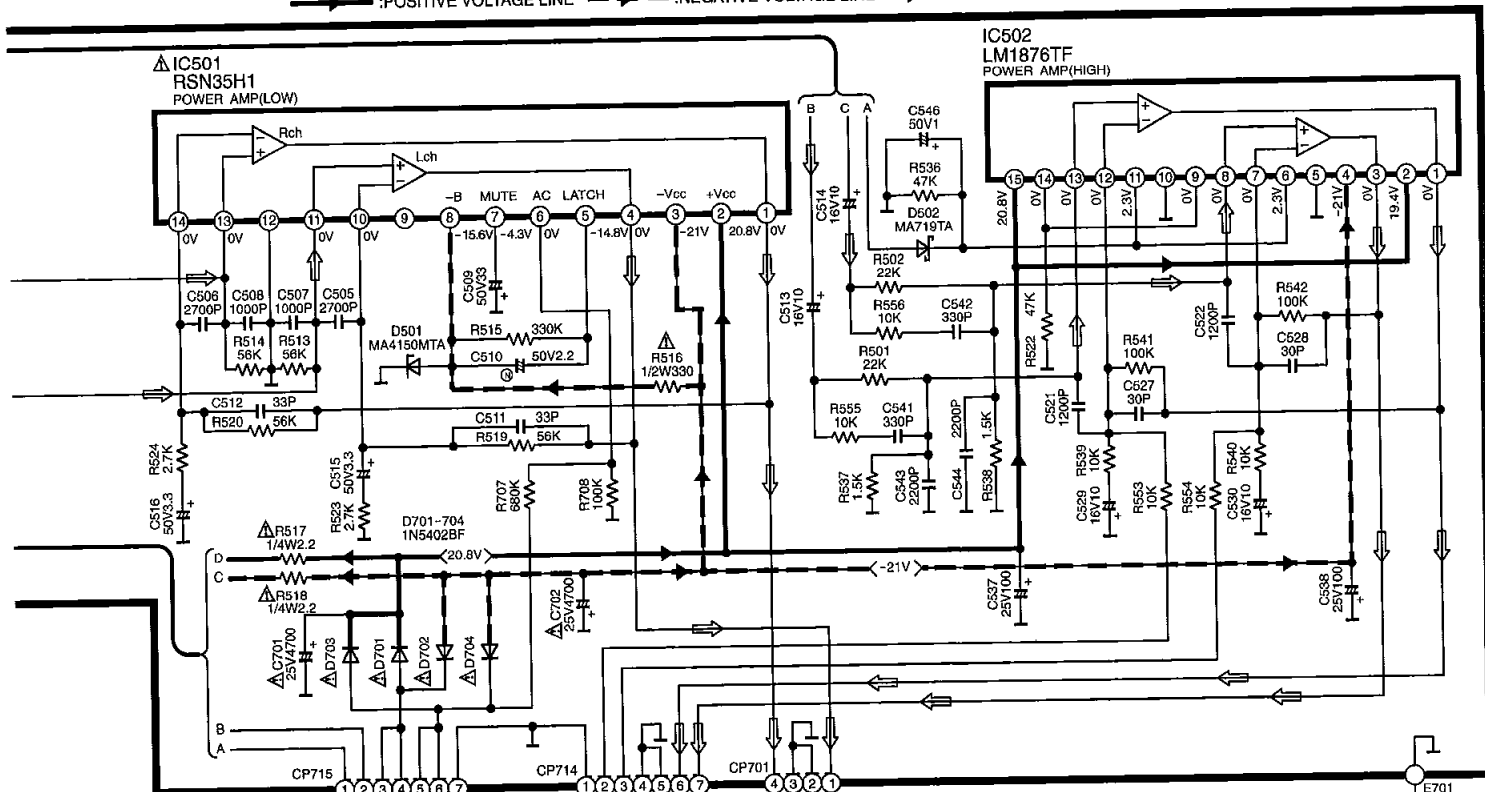

G SPEAKER TERMINAL CIRCUIT

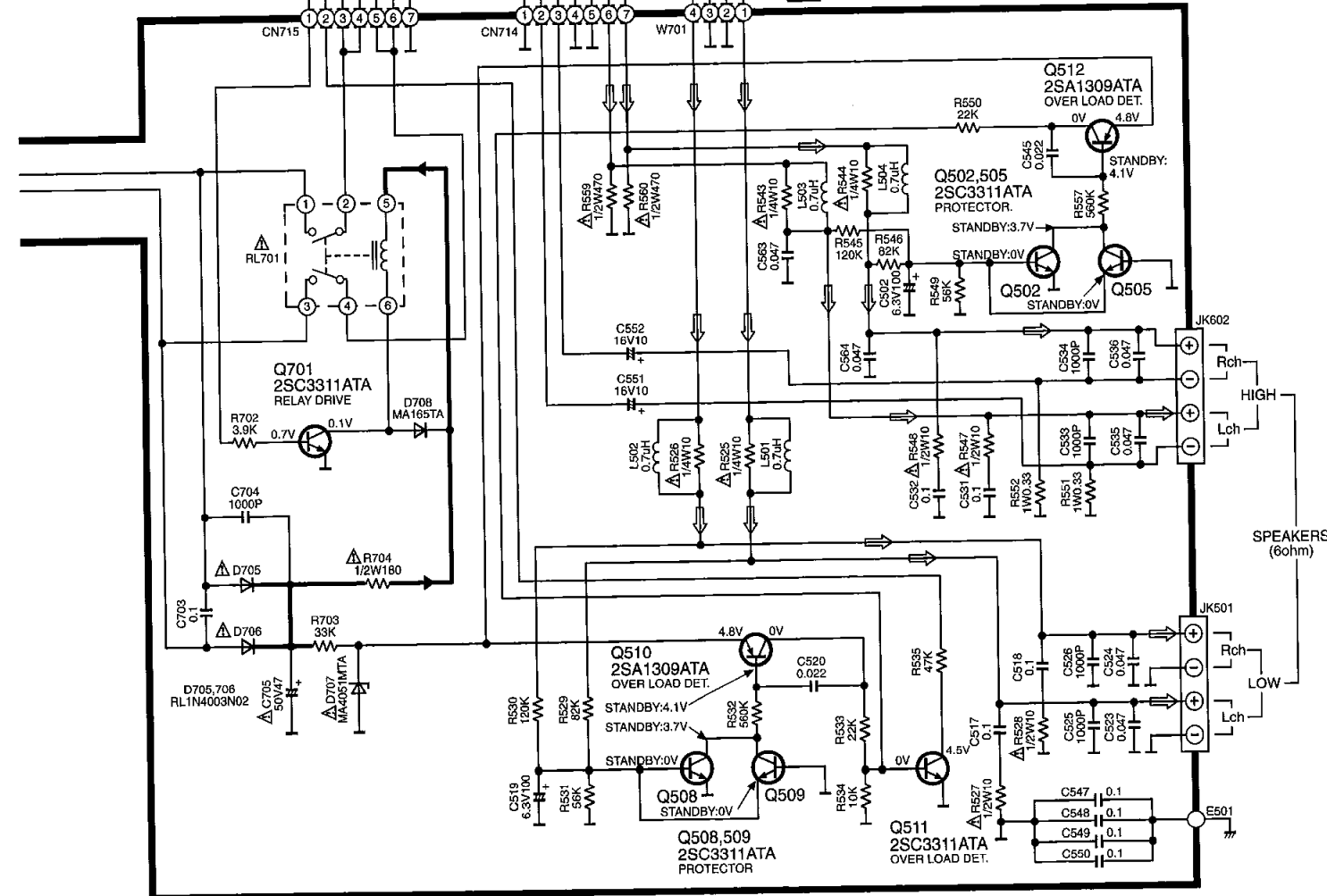

9 Printed Circuit Board Diagram

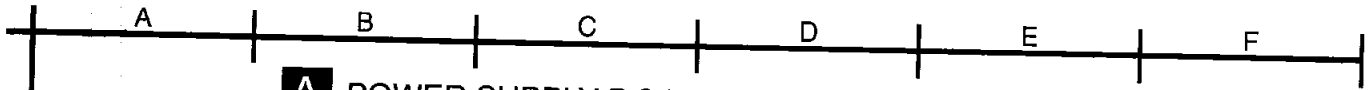

A POWER SUPPLY P.C.B.

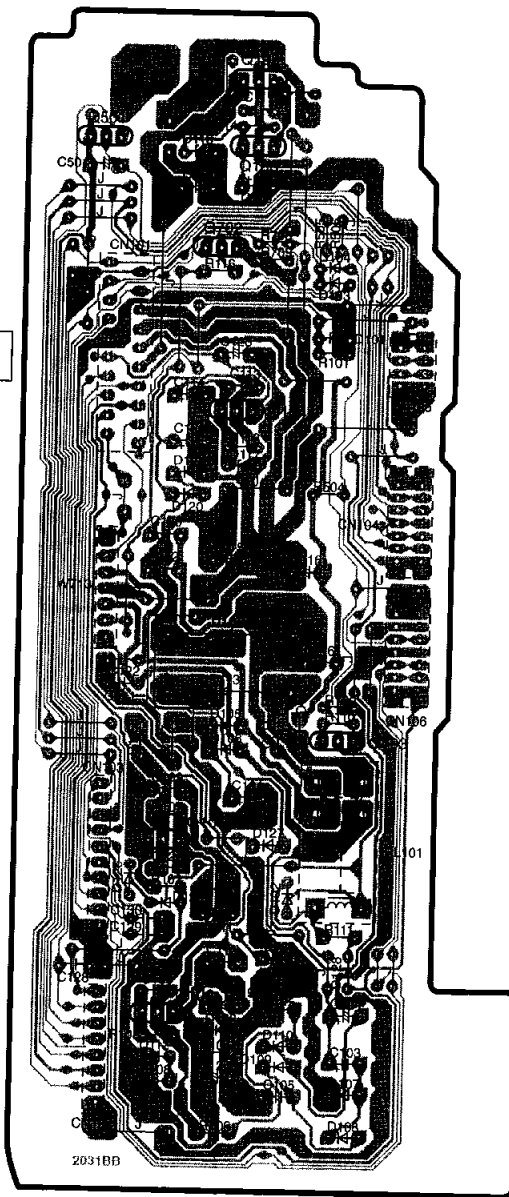

G SPEAKER TERMINAL P.C.B.

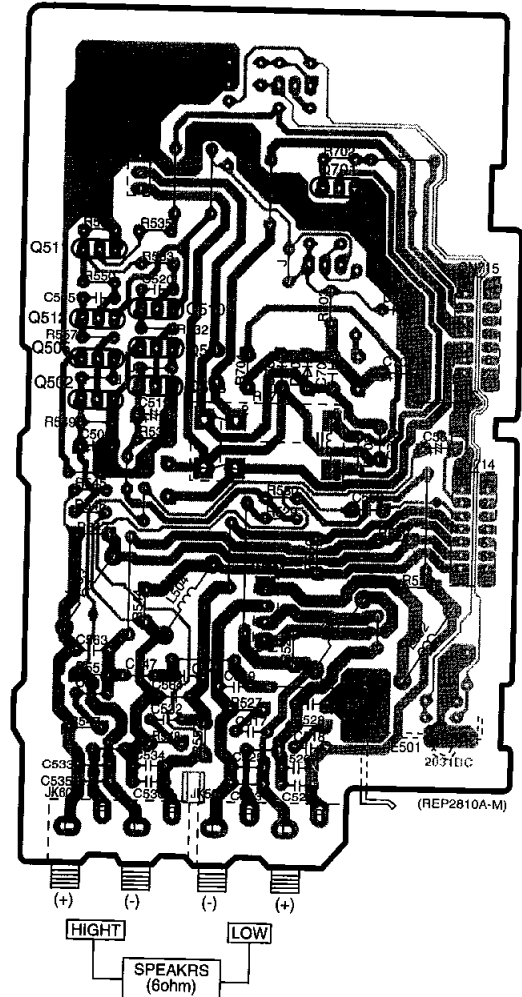

ELECTRICAL PARTS LOCATION

(REP2810A-M)

Ref. No.	Lo. No.	Ref. No.	Lo. No.	Ref. No.	Lo. No.	Ref. No.	Lo. No.	Ref. No.	Lo. No.	Ref. No.	Lo. No.	Ref. No.	Lo. No.	Ref. No.	Lo. No.	Ref. No.	Lo. No.
A POWER SUPPLY P.C.B.																	
Q101	5B	D104	2C	D115	4C	D128	5C	R104	6C	R117	4B	C106	5B	C117	1C	C128	5B
Q102	5B	D105	4C	D116	4C	RL101	5C	R105	4B	R504	3C	C107	5C	C118	2C	C129	5B
Q103	4C	D106	4C	D117	3C	CN101	2B	R106	6C	R505	2C	C108	6B	C119	2B	C130	5B
Q104	3C	D107	6C	D118	2B	CN102	6B	R107	5B	R506	2C	C109	4B	C120	3B	C501	2B
Q105	1C	D108	6C	D119	5C	CN103	5B	R108	6B	R706	2C	C110	5C	C121	4B		
Q106	2C	D109	6C	D120	3B	CN104	3C	R109	4C	R709	2C	C111	4C	C122	4B		
Q501	2B	D110	6C	D123	6C	CN105	3C	R110	4C	C101	4C	C112	3B	C123	2C		
G702	2C	D111	5C	D124	3B	CN106	4C	R111	5C	C102	5C	C113	3C	C124	6C		
D101	2C	D112	6B	D125	5B	W713	3B	R113	3C	C103	6C	C114	3B	C125	5B		
D102	5C	D113	4C	D126	5B	R101	2C	R114	1C	C104	5C	C115	3C	C126	3B		
D103	2C	D114	4C	D127	5C	R102	5B	R116	2C	C105	6C	C116	3C	C127	5C		
G SPEAKER TERMINAL P.C.B.																	
Q502	3D	D706	3E	CN715	3F	R528	4E	R544	4E	R557	3D	C519	3E	C534	5E	C552	3F
Q505	3D	D707	2F	CN716	2E	R529	3E	R545	3D	R559	4F	C520	2E	C535	5D	C563	4D
Q508	3E	D708	3F	W701	4E	R530	3E	R546	3D	R560	4E	C523	5E	C536	5E	C564	4E
Q509	3E	L501	4F	JK501	5E	R531	3E	R547	4D	R702	2F	C524	5E	C545	2D	C703	3F
Q510	3E	L502	4F	JK602	5D	R532	3E	R548	4E	R703	2E	C525	5E	C547	4E	C704	3F
Q511	2D	L503	4D	E501	4F	R533	2E	R549	3D	R704	3E	C526	5E	C548	4E	C705	3F
Q512	3D	L504	4E	R525	4E	R534	2D	R550	2D	C502	3D	C531	4D	C549	4E		
Q701	2F	RL701	3E	R526	4F	R535	2E	R551	4D	C517	4E	C532	4E	C550	4E		
D705	3E	CN714	3F	R527	4E	R543	4D	R552	4E	C518	4E	C533	5D	C551	3F		

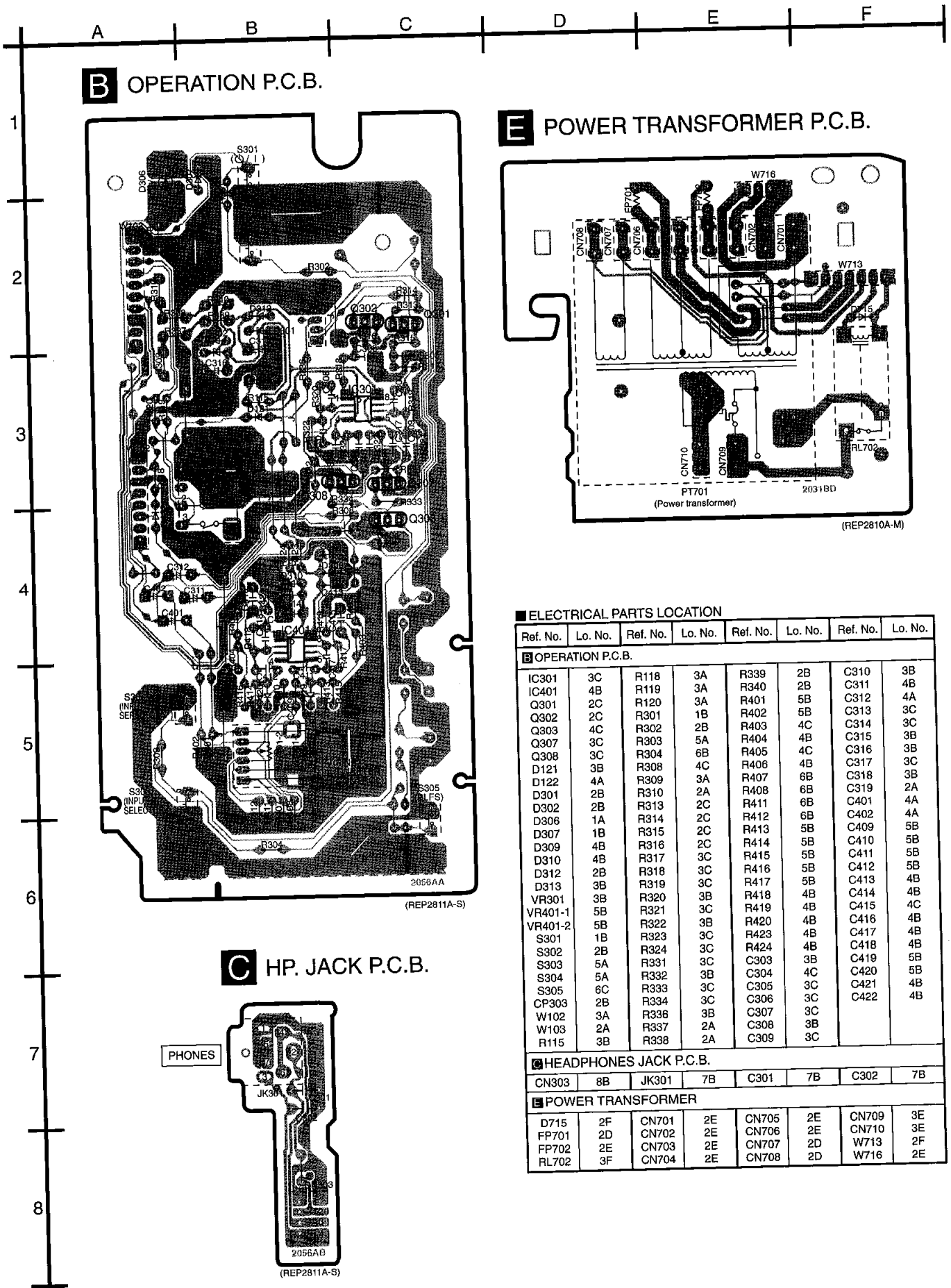

B OPERATION P.C.B.

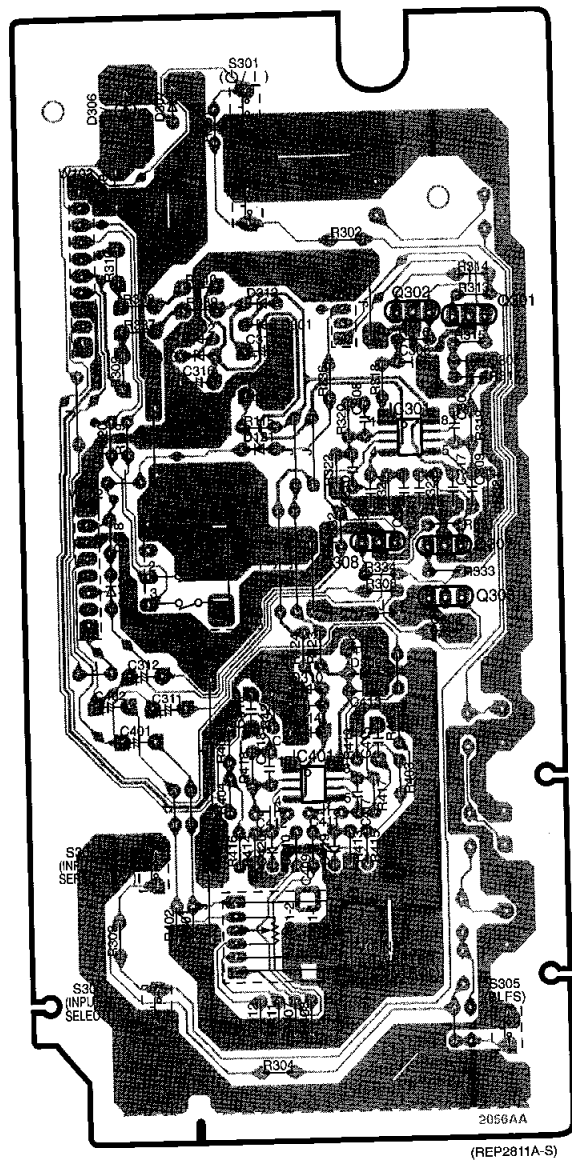

E POWER TRANSFORMER P.C.B.

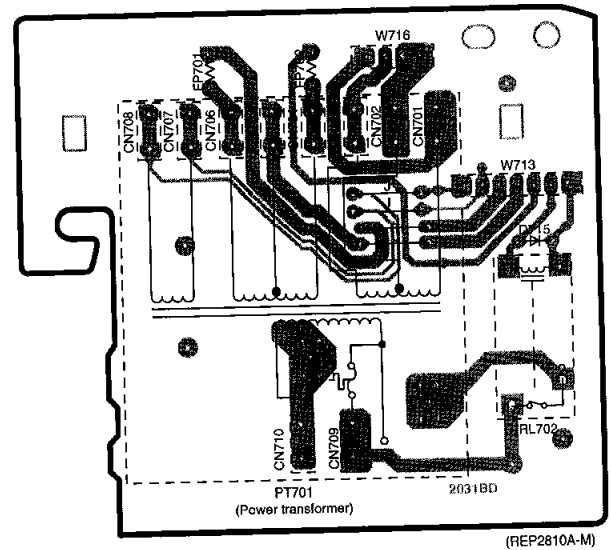

C HP. JACK P.C.B.

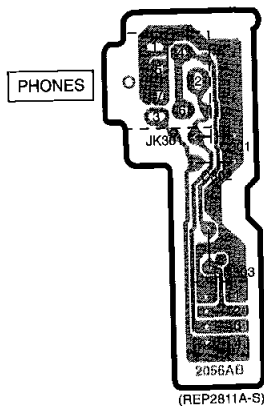

ELECTRICAL PARTS LOCATION

Ref. No.	Lo. No.	Ref. No.	Lo. No.	Ref. No.	Lo. No.	Ref. No.	Lo. No.
B OPERATION P.C.B.							
IC301	3C	R118	3A	R339	2B	C310	3B
IC401	4B	R119	3A	R340	2B	C311	4B
Q301	2C	R120	3A	R401	5B	C312	4A
Q302	2C	R301	1B	R402	5B	C313	3C
Q303	4C	R302	2B	R403	4C	C314	3C
Q307	3C	R303	5A	R404	4B	C315	3B
Q308	3C	R304	6B	R405	4C	C316	3B
D121	3B	R308	4C	R406	4B	C317	3C
D122	4A	R309	3A	R407	6B	C318	3B
D301	2B	R310	2A	R408	6B	C319	2A
D302	2B	R313	2C	R411	6B	C401	4A
D306	1A	R314	2C	R412	6B	C402	4A
D307	1B	R315	2C	R413	5B	C409	5B
D309	4B	R316	2C	R414	5B	C410	5B
D310	4B	R317	3C	R415	5B	C411	5B
D312	2B	R318	3C	R416	5B	C412	5B
D313	3B	R319	3C	R417	5B	C413	4B
VR301	3B	R320	3B	R418	4B	C414	4B
VR401-1	5B	R321	3C	R419	4B	C415	4C
VR401-2	5B	R322	3B	R420	4B	C416	4B
S301	1B	R323	3C	R423	4B	C417	4B
S302	2B	R324	3C	R424	4B	C418	4B
S303	5A	R331	3C	C303	3B	C419	5B
S304	5A	R332	3B	C304	4C	C420	5B
S305	6C	R333	3C	C305	3C	C421	4B
CP303	2B	R334	3C	C306	3C	C422	4B
W102	3A	R336	3B	C307	3C		
W103	2A	R337	2A	C308	3B		
R115	3B	R338	2A	C309	3C		
C HEADPHONES JACK P.C.B.							
CN303	8B	JK301	7B	C301	7B	C302	7B
E POWER TRANSFORMER							
D715	2F	CN701	2E	CN705	2E	CN709	3E
FP701	2D	CN702	2E	CN706	2E	CN710	3E
FP702	2E	CN703	2E	CN707	2D	W713	2F
RL702	3F	CN704	2E	CN708	2D	W716	2E



F MAIN P.C.B.

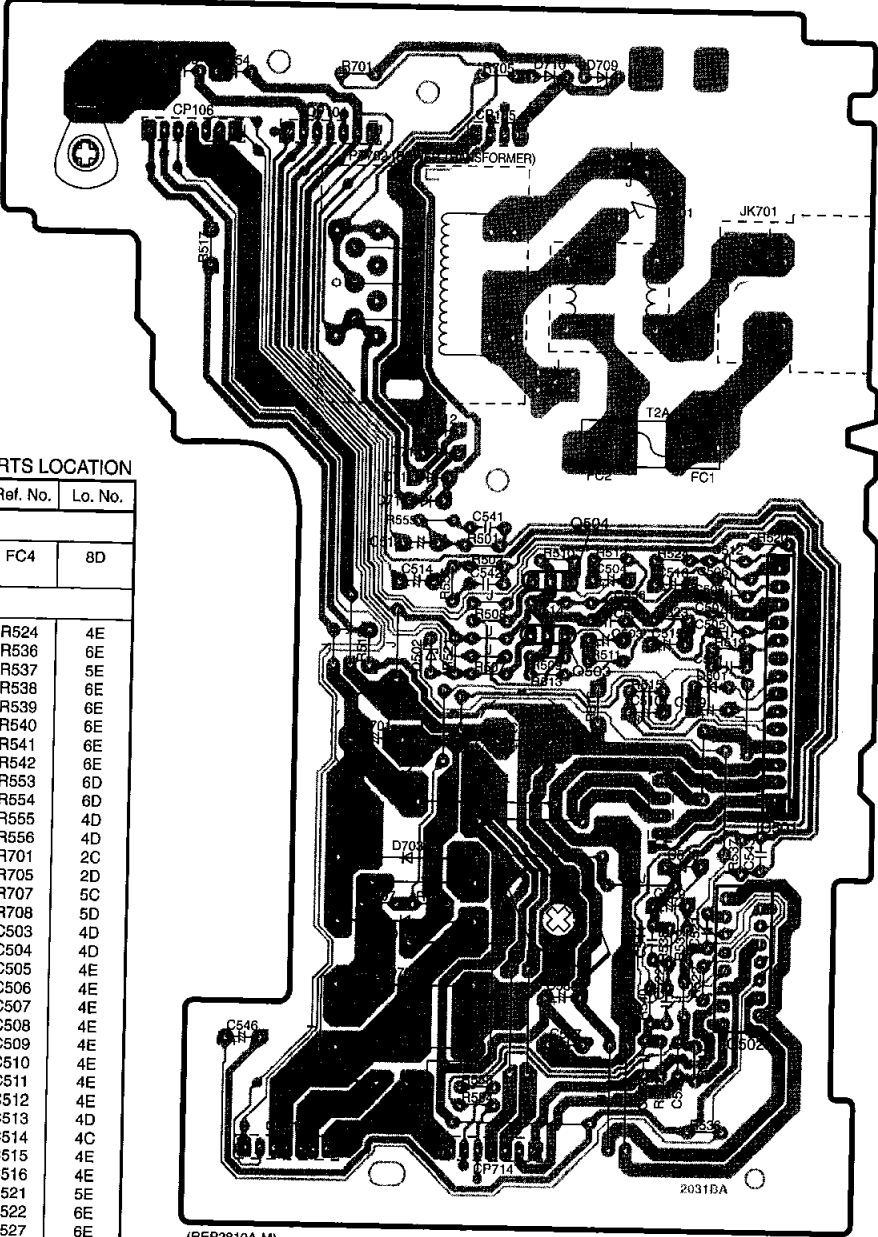

AC IN
 (230V.....[E,EG,EP])
 (230-240V....[EB])
 50Hz

ELECTRICAL PARTS LOCATION

Ref. No.	Lo. No.	Ref. No.	Lo. No.
FUSE P.C.B.			
F1	8D	FC4	8D
FC3	8D		
MAIN P.C.B.			
IC501	4E	R524	4E
IC502	6E	R536	6E
Q503	4D	R537	5E
Q504	4D	R538	6E
D501	4E	R539	6E
D502	4D	R540	6E
D701	5C	R541	6E
D702	6C	R542	6E
D703	5C	R553	6D
D704	6C	R554	6D
D709	2D	R555	4D
D710	2D	R556	4D
D711	3D	R701	2C
D712	3D	R705	2D
D713	4D	R707	5C
D714	3D	R708	5D
L701	3D	C503	4D
Z701	2E	C504	4D
F2	3E	C505	4E
E502	2B	C506	4E
E701	5D	C507	4E
CP104	2C	C508	4E
CP105	2D	C509	4E
CP106	2B	C510	4E
CP701	5E	C511	4E
CP714	6D	C512	4E
CP715	6C	C513	4D
JK701	2E	C514	4C
PT702	2C	C515	4E
FC1	3E	C516	4E
FC2	3D	C521	5E
R501	4D	C522	6E
R502	4D	C527	6E
R507	4D	C528	6E
R508	4D	C529	5E
R509	4D	C530	5E
R510	4D	C537	6D
R511	4D	C538	6D
R512	4D	C541	4D
R513	4D	C542	4D
R514	4D	C543	5E
R515	4E	C544	6E
R516	4D	C546	6C
R517	2C	C553	2B
R518	4C	C554	2C
R519	4E	C555	4D
R520	4E	C556	4D
R521	4D	C701	5C
R522	6E	C702	5D
R523	4E		

D FUSE P.C.B.

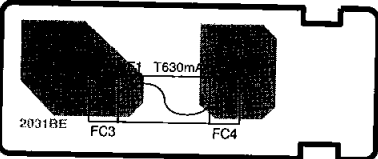

(REP2810A-M)

10 Block Diagram

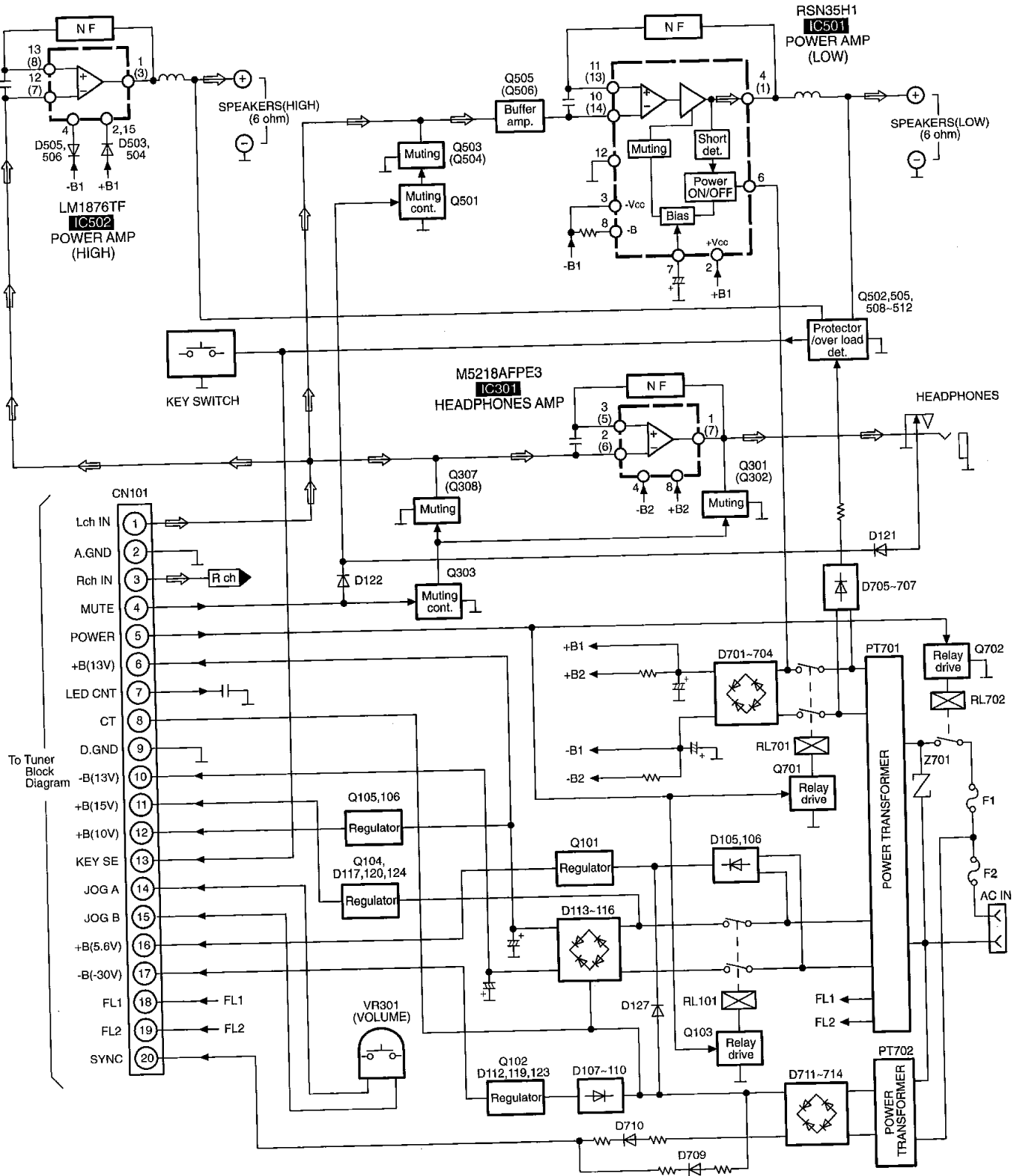

Notes
 ● Signal line ➡ Source signal
 ● () indicates pin No. Right channel.

11 Wiring Connection Diagram

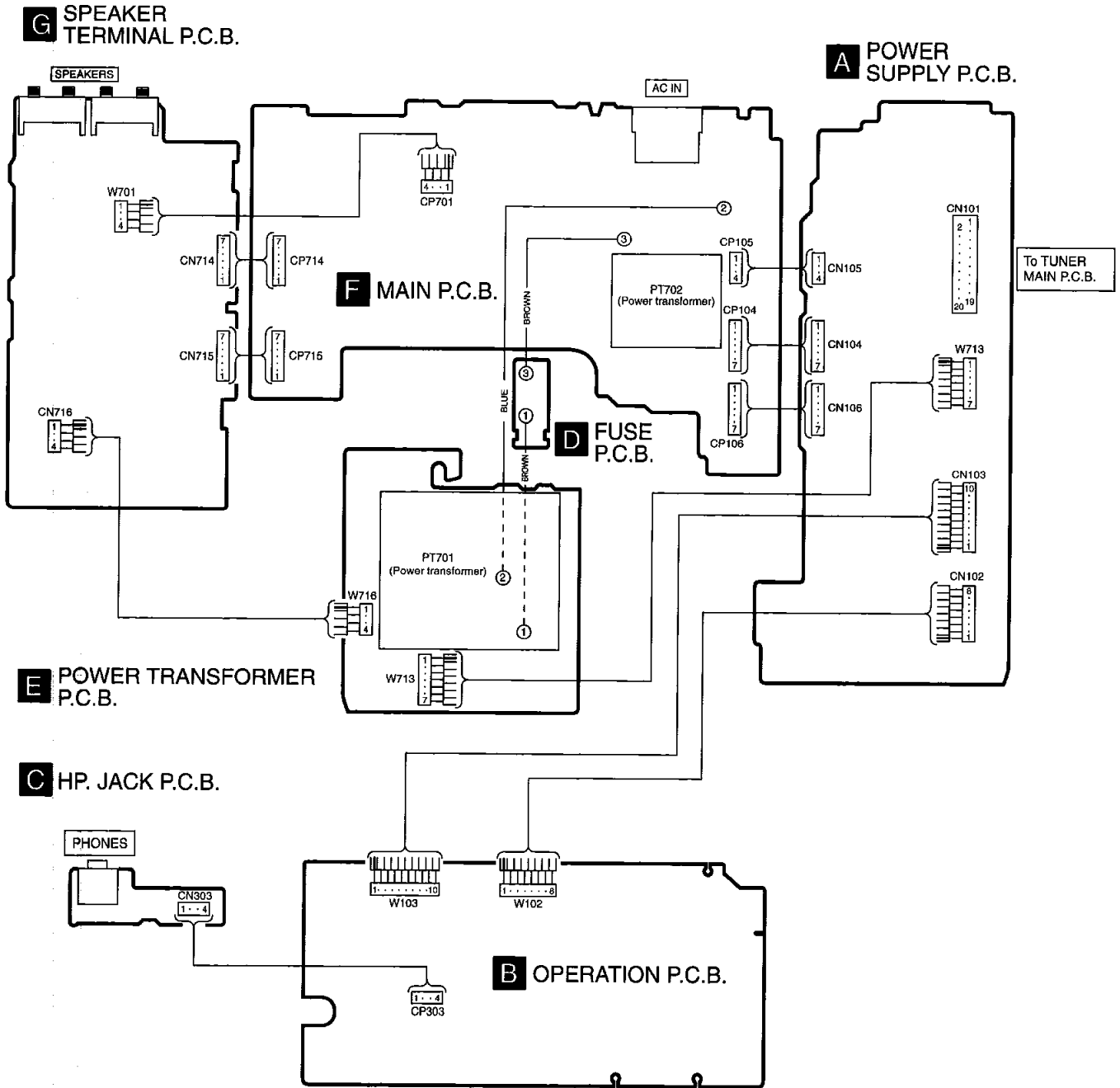

12 Replacement Parts List

Notes:

* Important safety notice:

Components identified by Δ mark have special characteristics important for safety.

Furthermore, special parts which have purposes of fire-retardant (resistors), high-quality sound (capacitors), low-noise (resistors), etc. are used.

When replacing any of components, be sure to use only manufacturer's specified parts shown in the parts list.

* The parenthesized indications in the Remarks columns specify the areas.

Parts without these indications can be used for all areas.

* Remote Control Ass'y: Supply period for three years from terminal of production.

* Capacity values are in microfarads (uF) unless specified otherwise, P=Pico-farads(pF), F=Farads (F)

* Resistance values are in ohms, unless specified otherwise, 1K=1,000 (OHM), 1M=1,000K (OHM)

* "<IA>, <IB>, <IC>, <ID>, <IE>" marks in Remarks indicate language of instruction manual.

[<IA>: Germany/Italian/French, <IB>: Dutch/Danish, <IC>: English/Spanish, <ID>: English, <IE>: Czeco/Polish]

Ref. No.	Part No.	Part Name & Description	Pcs	Remarks
1	RHD30073-K	SCREW	4	
2	RKM0397-S	CABINET	1	
3	XTBS3+10JFZ1	SCREW	1	
4	XTB3+8JFZ	SCREW	3	
5	RGH0154-K	NAME PLATE	1	(E) (EG)
5	RGH0154A-K	NAME PLATE	1	(EB)
5	RGH0154F-K	NAME PLATE	1	(EP)
6	RGW0319-S	KNOB VOLUME	1	
7	RKA0076-N1	FOOT	4	
7-1	RKA0083-K	CUSHION	4	
8	XTB3+6G	SCREW	4	
9	RFKGEHD501EN	FRONT PANEL ASS'Y	1	
10	RGK1140-N	SIDE ORNAMENT (L)	1	
11	RGK1141-N	SIDE ORNAMENT (R)	1	
12	RGK0815A-N	VOLUME ORNAMENT	1	
13	RGU1750-S	BUTTON	1	
15	RHD26016	SCREW	1	
16	RHN90001	NUT	2	
17	XTBS26+8J	SCREW	5	
18	XTBS3+8JFZ1	SCREW	12	
19	XTB3+12FFZ	SCREW	1	
20	XTB3+20JFZ	SCREW	2	
21	XTW3+15T	SCREW	3	
22	REX0962	FLAT CABLE (20P)	1	
23	RGK1148-M	SIDE PANEL (L)	1	
24	RGK1149-M	SIDE PANEL (R)	1	
25	RGK1147-N	FINE TWEETER ORNAMENT	1	
26	RGW0316-S	KNOB FINE TWEETER	1	
27	RMV0186	BARRIER	1	
28	RHD30081	SCREW	1	
A1	RAK-HDA07WH	REMOTE CONT. TRANSMITTER	1	
A1-1	RKK0123-K	BATT. COVER (REMOTE CONT.)	1	
A2	REE0499	SPEAKER CORD	2	
A3	RJA0019-X	AC POWER SUPPLY CORD	1	(E) (EG) (EP)
Δ A3	RJA0053-2X	AC POWER SUPPLY CORD	1	(EB)

Ref. No.	Part No.	Part Name & Description	Pcs	Remarks
A4	RQA0117	WARRANTY CARD	1	(E) (EB) (EG)
A5	RQCB0169	SERVICENTER LIST	1	(E) (EB) (EG)
A6	RQT4888-D	INSTRUCTION MANUAL	1	(EG) <IA>
A6	RQT4889-H	INSTRUCTION MANUAL	1	(EG) <IB>
A6	RQT4890-E	INSTRUCTION MANUAL	1	(E) <IC>
A6	RQT4891-B	INSTRUCTION MANUAL	1	(EB) (EP) <ID>
A6	RQT4892-R	INSTRUCTION MANUAL	1	(EP) <IE>
A7	RSA0007	FM INDOOR ANTENNA	1	
A8	RSA0021	AM LOOP ANTENNA	1	
A9	RQCA0664	QUICK SETUP GUIDE	1	(EB)
A10	SJP9009	AC PLUG ADAPTOR	1	(EB)
Δ A11	REE0853	SPEAKER CORD	2	
C101	RCE1EM471BV	25V 470U	1	
Δ C102	ECA2AM470	100V 47U	1	
Δ C103	ECA1EM101	25V 100U	1	
C104,05	ECA1HM470B	50V 47U	2	
Δ C106	ECBT1E103ZF	25V 0.01U	1	
C107	RCE1AKA470BG	10V 47U	1	
C108	RCE1VKA100BG	35V 10U	1	
C109	RCE1AKA470BG	10V 47U	1	
C110	ECEA1VKS470	35V 47U	1	
C111,12	ECKR1H103ZF5	50V 0.01U	2	
C113	ECBT1E103ZF	25V 0.01U	1	
C114	ECA1EM101	25V 100U	1	
C115	ECA1EM222	25V 2200U	1	
Δ C116	RCE1EM471BV	25V 470U	1	
C117	ECBT1E103ZF	25V 0.01U	1	
C118,19	RCE1CKA100BG	16V 10U	2	
C120	ECA1EM101	25V 100U	1	
Δ C121,22	ECBT1E103ZF	25V 0.01U	2	
C123,24	ECEA1EKS4R7	25V 4.7U	2	
C125	ECBT1E103ZF	25V 0.01U	1	
C126	ECA1HM470B	50V 47U	1	
C127	ECEA1CKS101	16V 100U	1	
Δ C128-30	ECBT1H101KB5	50V 100P	3	
C301,02	ECBT1H473ZF5	50V 0.047U	2	
C303	ECEA1AKS221	6.3V 220U	1	
C304	ECEA0JKS101	6.3V 100U	1	
C305,06	ECBT1E103ZF	25V 0.01U	2	
C307-10	ECBT1H101KB5	50V 100P	4	
C311,12	ECEA1HKS010	50V 1U	2	
C313,14	ECBT1H331KB5	50V 330P	2	
C315,16	ECEA1EKS4R7	25V 4.7U	2	
C317,18	ECBT1E103ZF	25V 0.01U	2	
C319	ECBT1H101KB5	50V 100P	1	
C401,02	ECEA1HKS010	50V 1U	2	
C409,10	ECBT1H561KB5	50V 560P	2	
C411,12	ECBT1H121KB5	50V 120P	2	
C413,14	ECBT1E103ZF	25V 0.01U	2	
C415,16	ECQV1H683JM3	50V 0.068U	2	
C417,18	ECBT1H150JC5	50V 15P	2	
C419,20	ECBT1H561KB5	50V 560P	2	
C421,22	RCE1CKA100BG	16V 10U	2	
C501	ECEA1CKN4R7	16V 4.7U	1	
C502	ECEA0JKS101	6.3V 100U	1	
C503,04	RCE1HKA3R3BG	50V 3.3U	2	
C505,06	ECBT1C272KR5	16V 2700P	2	
C507,08	ECBT1H102KB5	50V 1000P	2	
C509	ECEA1HKA330B	50V 33U	1	
C510	ECEA1HSN2R2	50V 2.2U	1	
C511,12	ECBT1H330J5	50V 33P	2	

Ref. No.	Part No.	Part Name & Description	Pcs	Remarks
C513,14	RCE1CKA100BG	16V 10U	2	
C515,16	RCE1HKA3R3BG	50V 3.3U	2	
C517,18	ECBT1H104ZF5	50V 0.1U	2	
C519	ECEA0JKS101	6.3V 100U	1	
C520	ECBT1E223ZF	25V 0.022U	1	
C521,22	ECBT1C122KR5	16V 1200P	2	
C523,24	ECBT1H473ZF5	50V 0.047U	2	
C525,26	ECBT1H102KB5	50V 1000P	2	
C527,28	ECBT1H300J5	50V 30P	2	
C529,30	RCE1CKA100BG	16V 10U	2	
C531,32	ECBT1H104ZF5	50V 0.1U	2	
C533,34	ECBT1H102KB5	50V 1000P	2	
C535,36	ECBT1H473ZF5	50V 0.047U	2	
C537,38	ECA1EM101	25V 100U	2	
C541,42	ECBT1H331KB5	50V 330P	2	
C543,44	ECBT1C222KR5	16V 2200P	2	
C545	ECBT1E223ZF	25V 0.022U	1	
C546	ECEA1HKS010	50V 1U	1	
C547-50	ECBT1H104ZF5	50V 0.1U	4	
C551,52	RCE1CKA100BG	16V 10U	2	
C553,54	ECBT1H473ZF5	50V 0.047U	2	
C555,56	ECBT1C472KR5	16V 4700P	2	
C563,64	ECBT1H473ZF5	50V 0.047U	2	
C701,02	ECA1EM472	25V 4700U	2	
C703	ECQE1104KF3	100V 0.1U	1	
C704	ECKR2H102ZF5	500V 1000P	1	
C705	ECA1HM470B	50V 47U	1	
CN101	RJS2A5520-1	CONNECTOR (20P)	1	
CN102	RJS8T6ZA	CONNECTOR (8P)	1	
CN103	RJS10T6ZA	CONNECTOR (10P)	1	
CN104	RJU057W007	CONNECTOR (7P)	1	
CN105	RJU057W004	CONNECTOR (4P)	1	
CN106	RJU057W007	CONNECTOR (7P)	1	
CN303	RJU057W004	CONNECTOR (4P)	1	
CN701-10	RJS1A1101T1	CONNECTOR (1P)	10	
CN714,15	RJU057W007	CONNECTOR (7P)	2	
CN716	RJS4T6ZA	CONNECTOR (4P)	1	
CP104	RJT057W007-1	CONNECTOR (7P)	1	
CP105	RJT057W004-1	CONNECTOR (4P)	1	
CP106	RJT057W007-1	CONNECTOR (7P)	1	
CP303	RJT057W004-1	CONNECTOR (4P)	1	
CP701	RJS1A6604	CONNECTOR (4P)	1	
CP714,15	RJT057W007-1	CONNECTOR (7P)	2	
D101	MA4051M	DIODE	1	
D102-04	MA165	DIODE	3	
D105-10	RL1N4003N02	DIODE	6	
D111	MA4062M	DIODE	1	
D112	MA4240H	DIODE	1	
D113,14	1N5402BF	DIODE	2	
D115,16	RL1N4003N02	DIODE	2	
D117	MA4160M	DIODE	1	
D118	MA4110M	DIODE	1	
D119,20	RL1N4003N02	DIODE	2	
D121,22	MA165	DIODE	2	
D123,24	RL1N4003N02	DIODE	2	
D125,26	MA165	DIODE	2	
D127	RL1N4003N02	DIODE	1	
D128	MA165	DIODE	1	
D301,02	MA4075M	DIODE	2	
D306	SLR-325VC	LED	1	

Ref. No.	Part No.	Part Name & Description	Pcs	Remarks
D307	MA165	DIODE	1	
D309,10	MA4120M	DIODE	2	
D312,13	MA4075M	DIODE	2	
D501	MA4150M	DIODE	1	
D502	MA719TA	DIODE	1	
D701-04	1N5402BF	DIODE	4	
D705,06	RL1N4003N02	DIODE	2	
D707	MA4051M	DIODE	1	
D708-10	MA165	DIODE	3	
D711-14	RL1N4003N02	DIODE	4	
D715	MA165	DIODE	1	
F1	XBA2C06TB0	FUSE	1	
F2	XBA2C20TB0	FUSE	1	
FP701,02	RSFMB40KT-L	FUSE PROTECTOR	2	
IC301	M5218AFPE3	IC	1	
IC401	M5218AFPE3	IC	1	
IC501	RSN35H1	IC	1	
IC502	LM1876TF	IC	1	
JK301	RJJ37TN01-C	HEADPHONES	1	
JK501	RJR0054E	SPEAKER	1	
JK602	RJR0054H	4P SPEAKER TERMINAL	1	
JK701	SJS9236	AC INLET	1	
L501-04	SLQY07G-40	COIL CHOKE	4	
L701	RLQZ371	COIL LINE FILTER	1	
P1	RPF0139	PROTECTION BAG (F.B.)	1	
P2	RPG4393	PACKING CASE (CD/TUNER)	2	
P2	RPG4394	PACKING CASE (AMP./DECK)	2	
P3	RPN1186	CUSHION (AMP./DECK)	2	
P3	RPN1187	CUSHION (CD/TUNER)	2	
P4	RPG4314	PACKING CASE (SYSTEM)	1	(EG)
P4	RPG4315	PACKING CASE (SYSTEM)	1	(EP)
P4	RPG4316	PACKING CASE (SYSTEM)	1	(E)
P4	RPG4317	PACKING CASE (SYSTEM)	1	(EB)
P5	RPQ0771	PAD	1	
P6	SPP740-1	PROTECTION BAG	4	
PT701	RTP2M5B016	POWER TRANSFORMER	1	(EB)
PT701	RTP2M5E014	POWER TRANSFORMER	1	(E) (EP) (EG)
PT702	RTP1I3E001	POWER TRANSFORMER	1	
Q101	2SD2374PQAU	TRANSISTOR	1	
Q102	2SB621A-R	TRANSISTOR	1	
Q103	2SC3311ATA	TRANSISTOR	1	
Q104	2SC3940AQSTA	TRANSISTOR	1	
Q105	2SD2374PQAU	TRANSISTOR	1	

Ref. No.	Part No.	Part Name & Description	Pcs	Remarks
Q106 △	2SC3327A	TRANSISTOR	1	
Q301,02	2SC3327A	TRANSISTOR	2	
Q303	UN4115	TRANSISTOR	1	
Q307,08	2SC3327A	TRANSISTOR	2	
Q501	UN4115	TRANSISTOR	1	
Q502	2SC3311ATA	TRANSISTOR	1	
Q503,04	2SC3327A	TRANSISTOR	2	
Q505	2SC3311ATA	TRANSISTOR	1	
Q508,09	2SC3311ATA	TRANSISTOR	2	
Q510	2SA1309ATA	TRANSISTOR	1	
Q511	2SC3311ATA	TRANSISTOR	1	
Q512	2SA1309ATA	TRANSISTOR	1	
Q701,02	2SC3311ATA	TRANSISTOR	2	
R101	ERDS2FJ103	1/4W 10K	1	
R102	ERDS2FJ331	1/4W 330	1	
R104	ERDS2FJ101	1/4W 100	1	
R105,06 △	ERDS2FJ100	1/4W 10	2	
R107	ERDS2FJ222	1/4W 2.2K	1	
R108	ERDS2FJ472	1/4W 4.7K	1	
R109	ERDS2FJ473	1/4W 47K	1	
R110	ERDS2FJ392	1/4W 3.9K	1	
R111 △	ERDS1FJ181	1/2W 180	1	
R113	ERDS2FJ392	1/4W 3.9K	1	
R114	ERDS2FJ102	1/4W 1K	1	
R115	ERDS2FJ472	1/4W 4.7K	1	
R116 △	ERD25FVJ560T	1/4W 56	1	
R117 △	ERD2FCG100	1/4W 10	1	
R118-20	ERDS2FJ102	1/4W 1K	3	
R301	ERDS2FJ821	1/4W 820	1	
R302	ERDS2FJ102	1/4W 1K	1	
R303	ERDS2FJ122	1/4W 1.2K	1	
R304	ERDS2FJ152	1/4W 1.5K	1	
R308	ERDS2FJ102	1/4W 1K	1	
R309,10 △	ERD25FVJ560T	1/4W 56	2	
R313,14	ERDS2FJ121	1/4W 120	2	
R315-18	ERDS2FJ470	1/4W 47	4	
R319,20	ERDS2FJ563	1/4W 56K	2	
R321-24	ERDS2FJ123	1/4W 12K	4	
R331,32	ERDS2FJ472	1/4W 4.7K	2	
R333,34	ERDS2FJ121	1/4W 120	2	
R336	ERDS2FJ121	1/4W 120	1	
R337-40 △	ERDS2FJ470	1/4W 47	4	
R401,02	ERDS2FJ104	1/4W 100K	2	
R403,04	ERDS2FJ223	1/4W 22K	2	
R405,06	ERDS2FJ182	1/4W 1.8K	2	
R407,08	ERDS2FJ473	1/4W 47K	2	
R411,12	ERDS2FJ223	1/4W 22K	2	
R413-16	ERDS2FJ104	1/4W 100K	4	
R417,18	ERDS2FJ333	1/4W 33K	2	
R419,20	ERDS2FJ152	1/4W 1.5K	2	
R423,24	ERDS2FJ331	1/4W 330	2	
R501,02	ERDS2FJ223	1/4W 22K	2	
R504	ERDS2FJ105	1/4W 1M	1	
R505-08	ERDS2FJ103	1/4W 10K	4	
R509,10	ERDS2FJ104	1/4W 100K	2	
R511,12	ERDS2FJ103	1/4W 10K	2	
R513,14	ERDS2FJ563	1/4W 56K	2	
R515	ERDS2FJ334	1/4W 330K	1	
R516	ERDS1FJ331	1/2W 330	1	
R517,18 △	ERDS2FJ2R2	1/4W 2.2	2	
R519,20	ERDS2FJ563	1/4W 56K	2	
R521	ERDS2FJ684	1/4W 680K	1	
R522	ERDS2FJ473	1/4W 47K	1	
R523,24	ERDS2FJ272	1/4W 2.7K	2	
R525,26 △	ERDS2FJ100	1/4W 10	2	

Ref. No.	Part No.	Part Name & Description	Pcs	Remarks
R527,28 △	ERDS1FJ100	1/2W 10	2	
R529	ERDS2FJ823	1/4W 82K	1	
R530	ERDS2FJ124	1/4W 120K	1	
R531	ERDS2FJ563	1/4W 56K	1	
R532	ERDS2FJ564	1/4W 560K	1	
R533	ERDS2FJ223	1/4W 22K	1	
R534	ERDS2FJ103	1/4W 10K	1	
R535,36	ERDS2FJ473	1/4W 47K	2	
R537,38	ERDS2FJ152	1/4W 1.5K	2	
R539,40	ERDS2FJ103	1/4W 10K	2	
R541,42	ERDS2FJ104	1/4W 100K	2	
R543,44 △	ERDS2FJ100	1/4W 10	2	
R545	ERDS2FJ124	1/4W 120K	1	
R546	ERDS2FJ823	1/4W 82K	1	
R547,48 △	ERDS1FJ100	1/2W 10	2	
R549	ERDS2FJ563	1/4W 56K	1	
R550	ERDS2FJ223	1/4W 22K	1	
R551,52	ERX1SJR33	1W 0.33	2	
R553-56	ERDS2FJ103	1/4W 10K	4	
R557	ERDS2FJ564	1/4W 560K	1	
R559,60 △	ERDS1FJ471	1/2W 470	2	
R701	ERDS2FJ102	1/4W 1K	1	
R702	ERDS2FJ392	1/4W 3.9K	1	
R703	ERDS2FJ333	1/4W 33K	1	
R704 △	ERDS1FJ181	1/2W 180	1	
R705	ERDS2FJ102	1/4W 1K	1	
R706	ERDS2FJ392	1/4W 3.9K	1	
R707	ERDS2FJ684	1/4W 680K	1	
R708	ERDS2FJ104	1/4W 100K	1	
R709	ERDS2FJ473	1/4W 47K	1	
RL101 △	RSY0017M-0	RELAY	1	
RL701 △	RSY0017M-0	RELAY	1	
RL702 △	RSY0040M-0	RELAY	1	
S301-05	EVQ21405R	SW PUSH	5	
VR301	EVQVBXFK124B	V.R. VOLUME	1	
VR401	EVJY91F04B54	V.R. FINE TWEETER CONT.	1	
Z701 △	ERZV10V511CS	COMPONENT COMBINATION	1	

13 Cabinet Parts Location

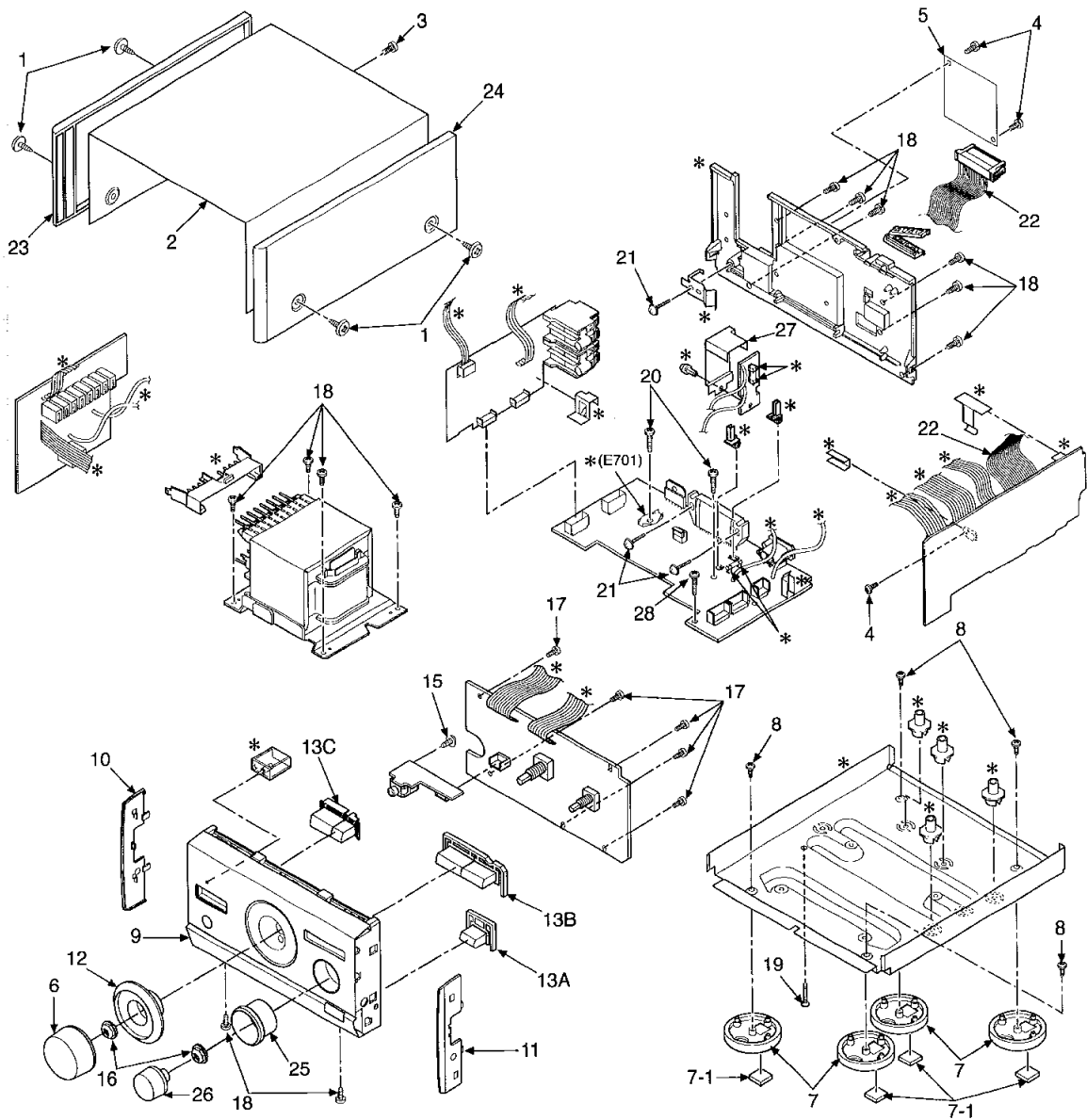

Note: We do not supply those items of parts marked *.

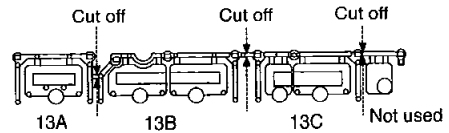

Ref. No.	Part No.	Part Name & Description	Pcs	Remarks
1	RHD30073-K	SCREW	4	
2	RKM0397-S	CABINET	1	
3	XTBS3+10JFZ1	SCREW	1	
4	XTB3+8JFZ	SCREW	3	
5	RGH0154-K	NAME PLATE	1	(E) (EG)
5	RGH0154A-K	NAME PLATE	1	(EB)
5	RGH0154F-K	NAME PLATE	1	(EP)
6	RGW0319-S	KNOB VOLUME	1	
7	RKA0076-N1	FOOT	4	
7-1	RKA0083-K	CUSHION	4	
8	XTB3+6G	SCREW	4	
9	RFKGEHD501EN	FRONT PANEL ASS'Y	1	
10	RGK1140-N	SIDE ORNAMENT (L)	1	
11	RGK1141-N	SIDE ORNAMENT (R)	1	
12	RGK0815A-N	VOLUME ORNAMENT	1	

Ref. No.	Part No.	Part Name & Description	Pcs	Remarks
13	RGU1750-S	BUTTON	1	
15	RHD26016	SCREW	1	
16	RHN90001	NUT	2	
17	XTBS26+8J	SCREW	5	
18	XTBS3+8JFZ1	SCREW	12	
19	XTB3+12FFZ	SCREW	1	
20	XTB3+20JFZ	SCREW	2	
21	XTW3+15T	SCREW	3	
22	REX0962	FLAT CABLE (20P)	1	
23	RGK1148-M	SIDE PANEL (L)	1	
24	RGK1149-M	SIDE PANEL (R)	1	
25	RGK1147-N	FINE TWEETER ORNAMENT	1	
26	RGW0316-S	KNOB FINE TWEETER	1	
27	RMV0186	BARRIER	1	
28	RHD30081	SCREW	1	

14 Packaging

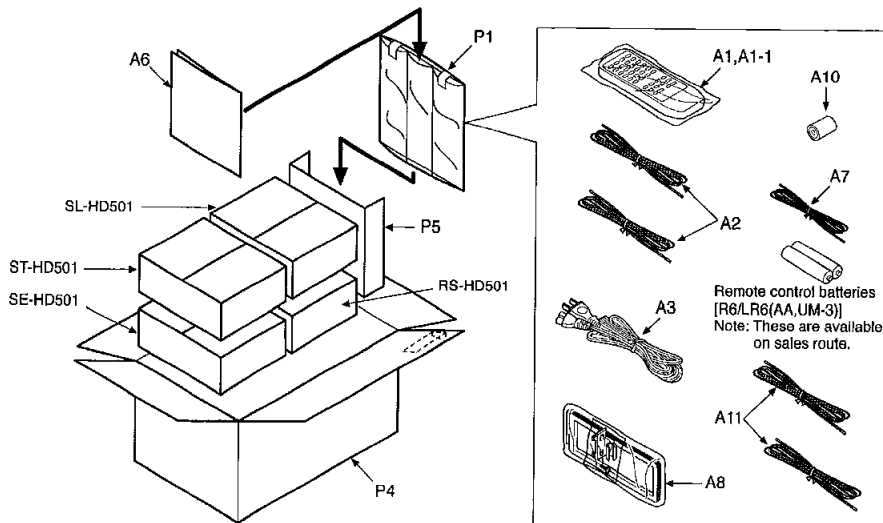
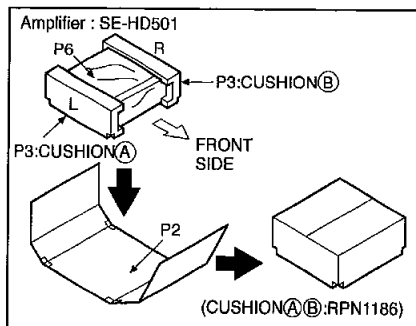
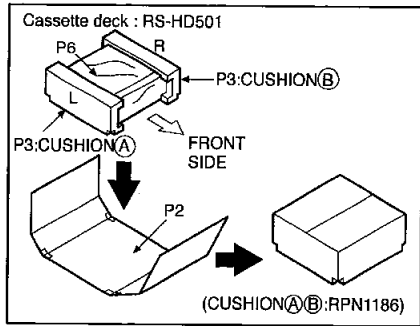
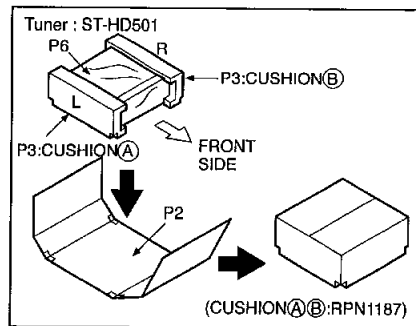
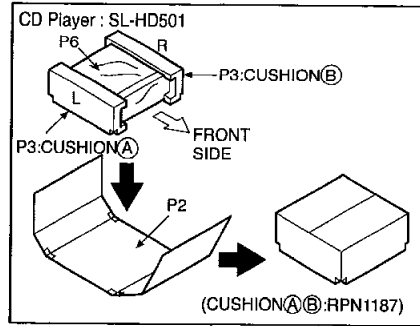

Ref. No.	Part No.	Part Name & Description	Pcs	Remarks
A1	RAK-HDA07WH	REMOTE CONT. TRANSMITTER	1	
A1-1	RKK0123-K	BATT. COVER (REMOTE CONT.)	1	
A2	REE0499	SPEAKER CORD	2	
A3	RJA0019-X	AC POWER SUPPLY CORD	1	(E) (EG) (EP)
A3	RJA0053-2X	AC POWER SUPPLY CORD	1	(EB)
A4	RQA0117	WARRANTY CARD	1	(E) (EB) (EG)
A5	RQCB0169	SERVICENTER LIST	1	(E) (EB) (EG)
A6	RQT4888-D	INSTRUCTION MANUAL	1	(EG) <IA>
A6	RQT4889-H	INSTRUCTION MANUAL	1	(EG) <IB>
A6	RQT4890-E	INSTRUCTION MANUAL	1	(E) <IC>
A6	RQT4891-B	INSTRUCTION MANUAL	1	(EB) (EP) <ID>
A6	RQT4892-R	INSTRUCTION MANUAL	1	(EP) <IE>
A7	RSA0007	FM INDOOR ANTENNA	1	
A8	RSA0021	AM LOOP ANTENNA	1	

Ref. No.	Part No.	Part Name & Description	Pcs	Remarks
A9	RQCA0664	QUICK SETUP GUIDE	1	(EB)
A10	SJP9009	AC PLUG ADAPTOR	1	(EB)
A11	REE0853	SPEAKER CORD	2	
P1	RPF0139	PROTECTION BAG (F.B.)	1	
P2	RPG4393	PACKING CASE (CD/TUNER)	2	
P2	RPG4394	PACKING CASE (AMP./DECK)	2	
P3	RPN1186	CUSHION (AMP./DECK)	2	
P3	RPN1187	CUSHION (CD/TUNER)	2	
P4	RPG4314	PACKING CASE (SYSTEM)	1	(EG)
P4	RPG4315	PACKING CASE (SYSTEM)	1	(EP)
P4	RPG4316	PACKING CASE (SYSTEM)	1	(E)
P4	RPG4317	PACKING CASE (SYSTEM)	1	(EB)
P5	RPQ0771	FAD	1	
P6	SPP740-1	PROTECTION BAG	4	

