

Service Manual

Amplifier

SE-HD505

Colour

(S).....Silver Type

Areas

PP.....U.S.A. and Canada.

E.....Europe.

EB.....Great Britain.

EG.....Germany and Italy, etc.

EP.....East Europe.

System: SC-HD505

Because of unique interconnecting cables, when a compact requires service, send or bring in the entire system.

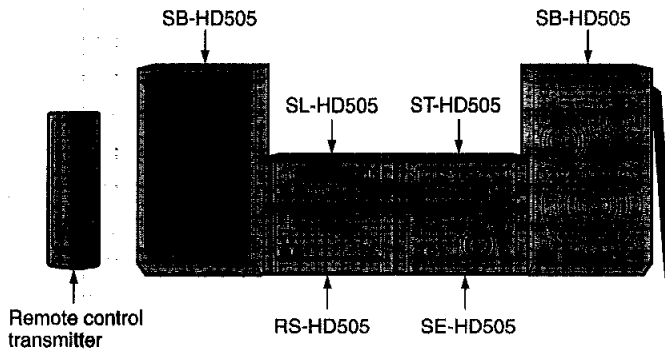

Specification

■Amplifier Section (Low frequency side)

Power Output [For (PP) area]

40-5500Hz, THD 1%, 6Ω both channels driven: 2x10W

Power output [For (E,EB,EG,EP) areas]

DIN 1 kHz, THD 1%, 6Ω both channels driven: 2x12W

RMS 1 kHz, THD 10%, 6Ω both channels driven: 2x15W

Total harmonic distortion

Half power at 1 kHz 6Ω: 0.09%

Load impedance:

6Ω

S/N:

75dB

■Amplifier Section (High frequency side)

Power output [For (PP) area]

5500-16000Hz, THD 1%, 6Ω, both channels driven: 2x5W

Power output [For (E,EB,EG,EP) areas]

DIN 10kHz, THD 1%, 6Ω, both channels driven: 2x15W

RMS 10kHz, THD 10%, 6Ω both channels driven: 2x8W

Load impedance:

6Ω

S/N:

75dB

Headphones

Jack type:

3.5mm STEREO

Load impedance:

16-32Ω

■General

Power consumption [For (PP) area]:

68W

Power consumption [For (E,EB,EG,EP) areas]:

77W

STANDBY condition

Normal:9W

Eco:0.8W

Power supply

[For (PP) area]:

AC120V,60Hz

[For (E,EG,EP) areas]:

AC230V,50Hz

[For (EB) area]:

AC230-240V,50Hz

Dimensions (WxHxD):

202x104.5x277mm

Weight:

3.5kg

Notes:

- 1.Design and specifications are subject to change without notice.
- 2.Dimensions and Weight are approximate.
- 3.Total harmonic distortion is measured by the digital spectrum analyzer.

■System/SC-HD505:

Tuner:ST-HD505, Compact Disc Player: SL-HD505, Amplifier:

SE-HD505, Cassette Deck: RS-HD505, Speakers: SB-HD505

(Made in MAES.)

Technics®

© 1999 Matsushita Electric Industrial Co., Ltd.
All rights reserved. Unauthorized copying and distribution is a violation of law.

⚠ WARNING

This service information is designed for experienced repair technicians only and is not designed for use by the general public. It does not contain warnings or cautions to advise non-technical individuals of potential dangers in attempting to service a product. Products powered by electricity should be serviced or repaired only by experienced professional technicians. Any attempt to service or repair the product or products dealt with in this service information by anyone else could result in serious injury or death.

CONTENTS

	Page		Page
1 Accessories	2	9.1. Type Illustration of IC's, Transistors and Diodes	11
2 Before Repair and Adjustment	3	9.2. Schematic Diagram Notes	12
3 Blue LED	3	10 Schematic Diagram	13
4 About the Protection Circuitry	3	11 Printed Circuit Board Diagram	16
5 Caution for AC Main Lead	4	12 Block Diagram	21
6 Operating Instructions	5	13 Wiring Connection Diagram	22
7 Operation Checks and Component Replacement Procedures	8	14 Replacement Parts List	23
8 Power Source ON/OFF and Signal Check	11	15 Cabinet Parts Location	27
9 Schematic Diagram Notes	11	16 Packaging	28

1 Accessories

- AC power supply cord.....1 pc.
 For (EB) area: (RJA0053-2X) For (E,EG,EP) areas: (RJA0019-2K) For (PP) area: (RJA0065-K)
- Antenna plug adaptor.....1 pc.
 For (EB) area only: (SJP9009)
- Remote control transmitter.....1 pc.
 (RAK-HDA10WH)
- Remote control batteries.....2 pcs.
 [(R6/LR6 (AA, UM-3)]
NOTE: These are available on sales route.
- FM indoor antenna1 pc.
 For (E,EB,EG,EP) areas: (RSA0007) For (PP) area: (RSA0006)
- AM loop antenna set (RSA0021)
 AM loop antenna.....1 pc.
 Antenna holder with stand.....1 pc.
- Antenna holder without stand.....1 pc.
 Screw1 pc.
- Speaker coards
 (REE0499).....2 pcs. (Red . Black)
 (REE0853).....2 pcs. (Gray . Blue)

2 Before Repair and Adjustment

1. Turn off the power supply. Using a 10Ω , 10W resistor, connect both ends of power supply capacitors (C102-105, 127) in order to discharge the voltage.
2. Before turning the power supply on, after completion of repair, slowly apply the primary voltage by using a power supply voltage controller to make sure that the consumed current at 50/60 Hz in NO SIGNAL mode should be shown below with respect to supply voltage 120V/230 V/240 V.

Areas	(E) (EG) (EP)		(EB)		(PP)	
Power supply voltage	AC 230V		AC 230-240V		AC 120V	
Consumed current	50 Hz	60-155 mA	50 Hz	55-145 mA	60Hz	105-305mA

3 Blue LED

- The LED mounted to each side of the front panel of this set is very sensitive to static electricity. When handling the LED base plate, be very careful about it.
 - Do not replace a blue LED singly. If replaced singly, it may be subject to electrostatic breakdown or deterioration in quality. When replacing the LED base plate, be sure to replace L and R sides simultaneously to permit the brightness adjustment.
- *For configuration at time of supply of replacement parts, refer to "Printed Circuit Board Diagram".



4 About the Protection Circuitry

The protection circuitry may have operated if either of the following conditions is noticed:

- *No sound is heard when the power is supplied.
- *Sound stops during a performance.

The functions of this circuitry is to prevent circuitry damage, for example, the positive and negative speaker connection wires are "shorted", or if speaker systems with an impedande less than the indicated rated impedance of this unit are used.

If this occurs, follow the procedure outlined below:

1. Press the STANDBY  /ON button, switch to STANDBY mode.
2. Determine the cause of the problem and correct it.
3. Press the STANDBY  /ON button once again, supply the power.

Note:

When the protection circuitry functions, the unit will not operate unless the STANDBY  /ON button is first switched STANDBY and then ON again.

5 Caution for AC Main Lead (For United Kingdom)

("EB" area code model only)

For your safety, please read the following text carefully.

This appliance is supplied with a moulded three pin mains plug for your safety and convenience.

A 5-ampere fuse is fitted in this plug.

Should the fuse need to be replaced please ensure that the replacement fuse has a rating of 5-ampere and that it is approved by ASTA or BSI to BS1362.

Check for the ASTA mark  or the BSI mark  on the body of the fuse.

If the plug contains a removable fuse cover you must ensure that it is refitted when the fuse is replaced.

If you lose the fuse cover the plug must not be used until a replacement cover is obtained.

A replacement fuse cover can be purchased from your local dealer.

CAUTION!

IF THE FITTED MOULDED PLUG IS UNSUITABLE FOR THE SOCKET OUTLET IN YOUR HOME THEN THE FUSE SHOULD BE REMOVED AND THE PLUG CUT OFF AND DISPOSED OF SAFELY.

THERE IS A DANGER OF SEVERE ELECTRICAL SHOCK IF THE CUT OFF PLUG IS INSERTED INTO ANY 13-AMPERE SOCKET.

If a new plug is to be fitted please observe the wiring code as shown below.

If in any doubt please consult a qualified electrician.

IMPORTANT

The wires in this mains lead are coloured in accordance with the following code:

Blue: Neutral, Brown: Live.

As these colours may not correspond with the coloured markings identifying the terminals in your plug, proceed as follows:

The wire which is coloured Blue must be connected to the terminal which is marked with the letter N or coloured Black or Blue.

The wire which is coloured Brown must be connected to the terminal which is marked with the letter L or coloured Brown or Red.

WARNING: DO NOT CONNECT EITHER WIRE TO THE EARTH TERMINAL WHICH IS MARKED WITH THE LETTER E, BY THE EARTH SYMBOL  OR COLOURED GREEN OR GREEN/YELLOW.

THIS PLUG IS NOT WATERPROOF & KEEP DRY.

Before use

Remove the connector cover.

How to replace the fuse

The location of the fuse differ according to the type of AC mains plug (figures A and B). Confirm the AC mains plug fitted and follow the instructions below. Illustrations may differ from actual AC mains plug.

1. Open the fuse cover with a screwdriver.

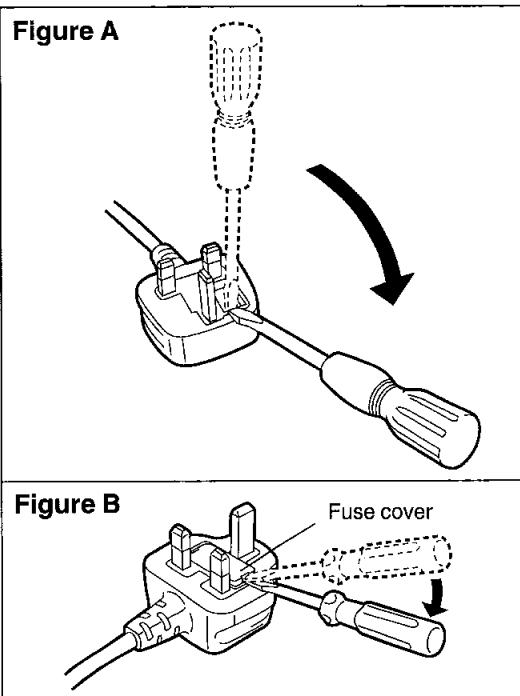

2. Replace the fuse and close or attach the fuse cover.

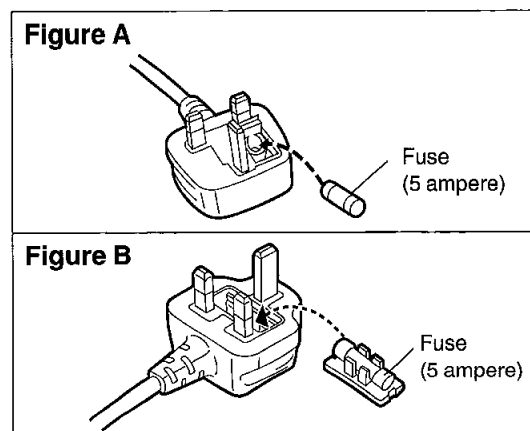

6 Operating Instructions

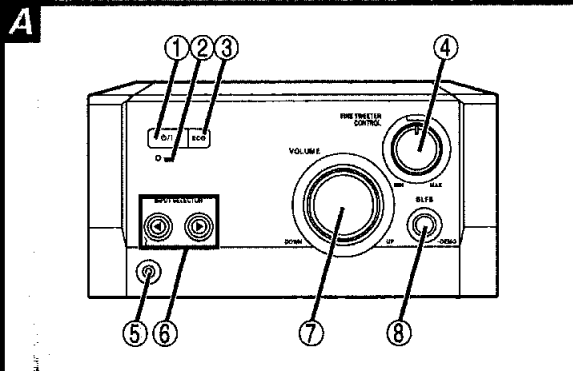

A Amplifier

- ① **Standby/on switch** (⏻/⏻)
Press to switch the unit from on to standby mode or vice versa. In standby mode, the unit is still consuming a small amount of power.
- ② **Standby indicator**
When the unit is connected to the AC mains supply, this indicator lights up in standby mode and goes out when the unit is turned on.
- ③ **ECO button (ECO)**
- ④ **Fine tweeter control (FINE TWEETER CONTROL)**
- ⑤ **Headphone jack** (⌚)
- ⑥ **Input selector (INPUT SELECTOR)**
- ⑦ **Volume control (VOLUME)**
- ⑧ **Bass, demo button (BLFS, -DEMO)**

B Remote control

Buttons ① and ② function in the same way as the controls on the main unit.

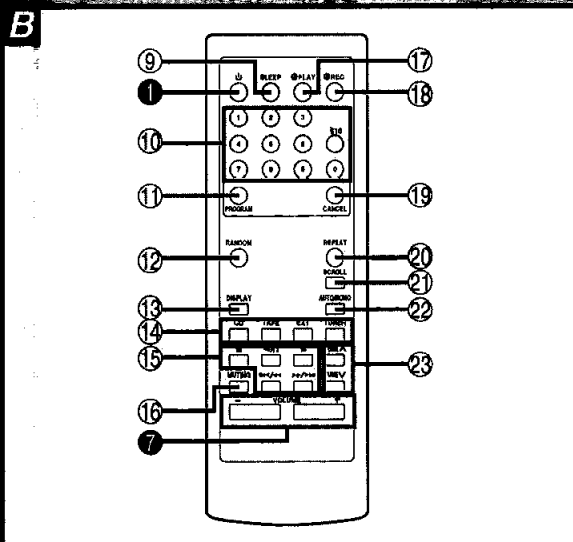

- ⑨ **Sleep timer button (SLEEP)**
- ⑩ **Numbered buttons**
- ⑪ **Program button (PROGRAM)**
- ⑫ **Random button (RANDOM)**
- ⑬ **Display select button (DISPLAY)**
- ⑭ **Input select buttons (CD, TAPE, EXT, TUNER)**
- ⑮ **Basic operating buttons**
Function changes according to the source.
- ⑯ **Muting button (MUTING)**
- ⑰ **Play timer button (⏻ PLAY)**
- ⑱ **Record timer button (⏻ REC)**
- ⑲ **Cancel button (CANCEL)**
- ⑳ **Repeat button (REPEAT)**
- ㉑ **Scroll button (SCROLL)**
- ㉒ **FM mode button (AUTO/MONO)**
- ㉓ **Tuning buttons (TUNE^, TUNE^v)**

C Installation

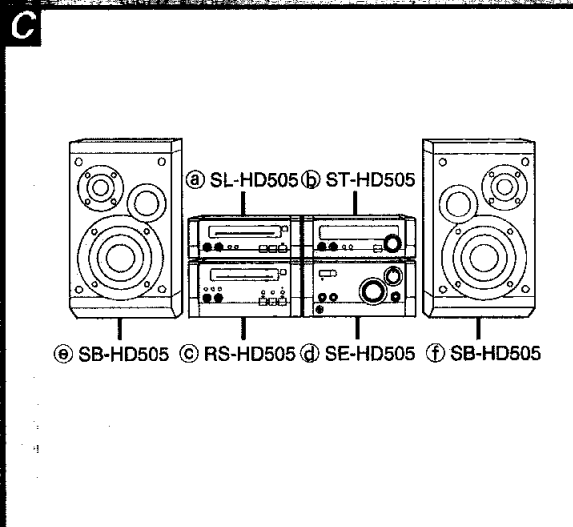

- ⓐ CD player
- ⓑ Tuner
- ⓒ Cassette deck
- ⓓ Amplifier
- ⓔ Left speaker
- ⓕ Right speaker

Note

Do not put the CD player on the amplifier. Heat from the amplifier can damage your CDs.



Caution

Use the speakers only with the recommended system. Failure to do so can damage the amplifier and speakers, and can cause fire. Consult a qualified service person if damage occurs or if a sudden change in performance is apparent. Do not attach these speakers to walls or ceilings.

These speakers are designed to be used close to a television, but the picture may be affected in some cases. If this occurs, turn the television off for about 30 minutes. The television's demagnetizing function should correct the problem. If it persists, move the speakers further away from the television.

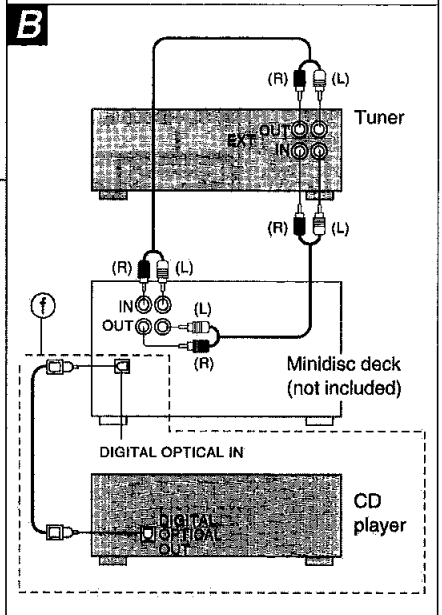
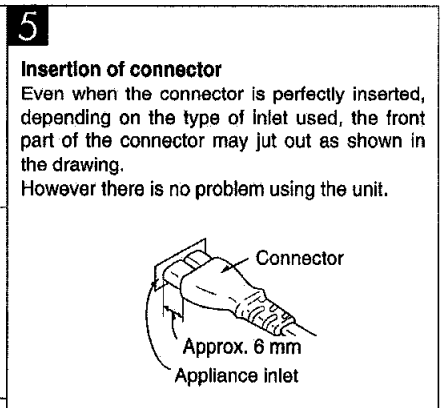
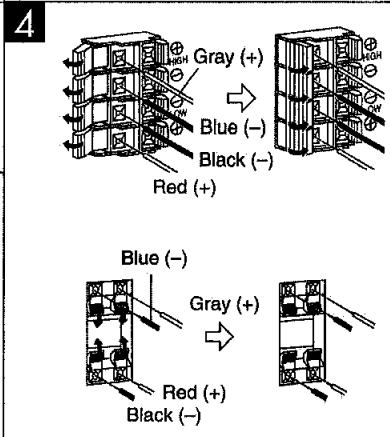
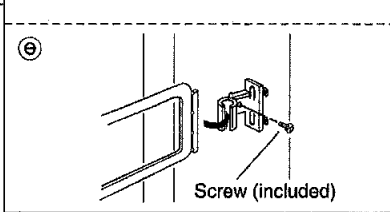
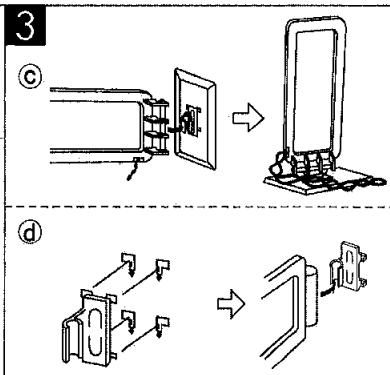
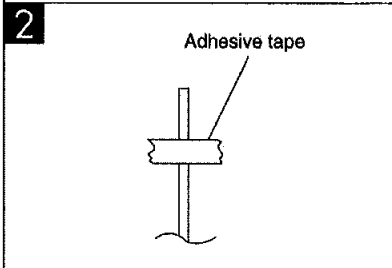
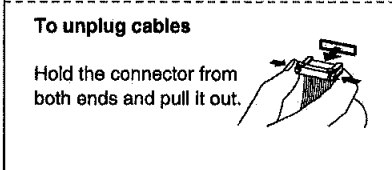
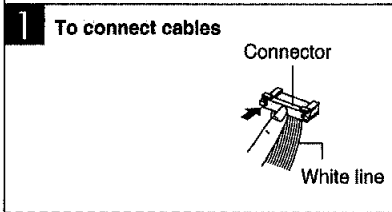
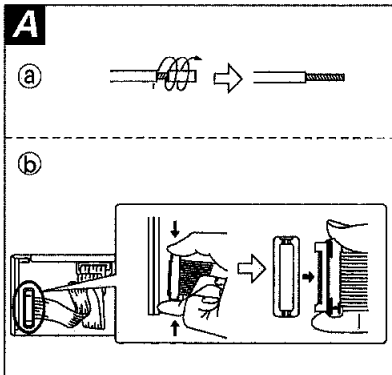
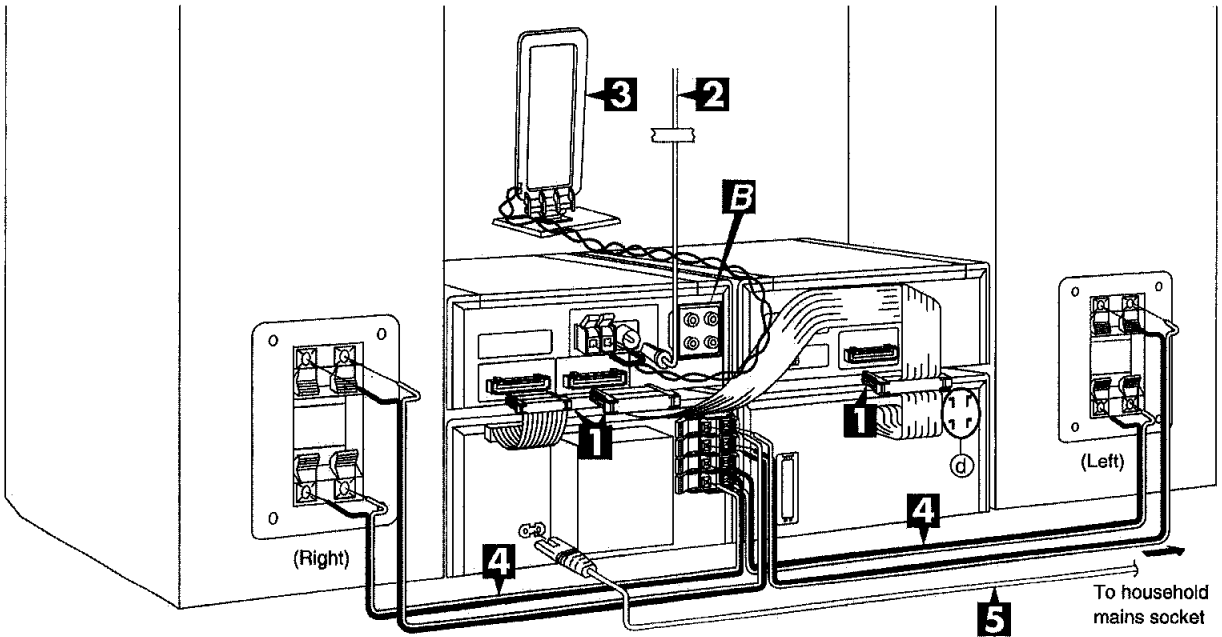

Basic connections for supplied accessories

A Before connection

Do not connect the AC mains lead until all other connections are complete.

To prepare the AM loop antenna, and speaker cables, twist the vinyl tip and pull off (a).

Disconnect the flat cable on the cassette deck (b).

1 Flat cables.

Keep the cables as flat as possible against the back of the unit.

2 FM antenna.

Fix the other end of the antenna where reception is best.

3 AM loop antenna.

Attach to the supplied antenna stand (c), or use the other holder and attach to the back of the cassette deck (d), a wall or pillar (e).

Keep loose antenna cord away from other wires and cords.

4 Speaker cables.

Connect the cables to the terminals of the same color. Never allow the exposed wires to contact each other when connected.

Use only the supplied speakers.

The combination of the system and the front speakers provides the best sound. Using other speakers can damage the unit and sound quality will be negatively affected.

(United Kingdom only)
BE SURE TO READ THE CAUTION FOR THE AC MAINS LEAD BEFORE PROCEEDING TO STEP 5.

5 Connect the AC mains lead.

For your reference

Information you enter into the unit's memory, except for time, remains intact for up to two weeks after the mains lead is disconnected.

B External unit connections

Turn off the power to all units before making connections. Refer to the manual of the other unit for details. (Cables and equipment not included.)

Connect other equipment to the EXT IN terminals to output sound through this unit's speakers or to record onto the cassette deck. Connect this unit to other equipment through the EXT OUT terminals to record onto another cassette deck or to output sound from this unit through the other unit.

Stereo phono cable (not included)

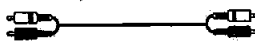
White (L) 
 Red (R)

Connections to DIGITAL OPTICAL OUT (f):

Use an optical fiber cable to connect to a minidisc deck. Remove the dust cap before use.

Optional antenna connections

Use outdoor antennas if radio reception is poor.

FM outdoor antenna

Note

Disconnect the FM indoor antenna. The antenna should be installed by a competent technician.

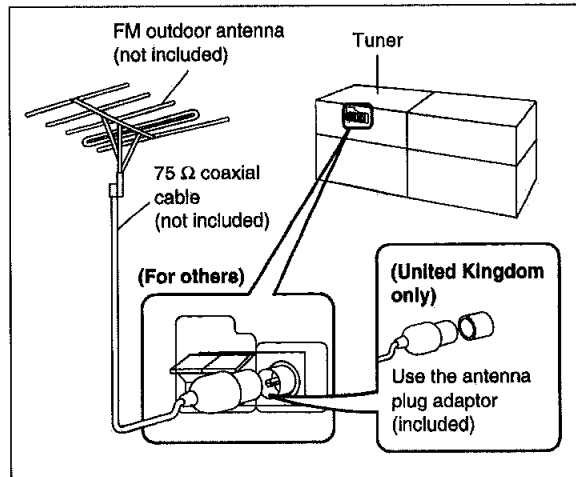

AM outdoor antenna

Run a piece of vinyl wire horizontally across a window or other convenient location.

Note

Leave the loop antenna connected. Disconnect the antenna when the unit is not in use. Do not use the antenna during an electrical storm.

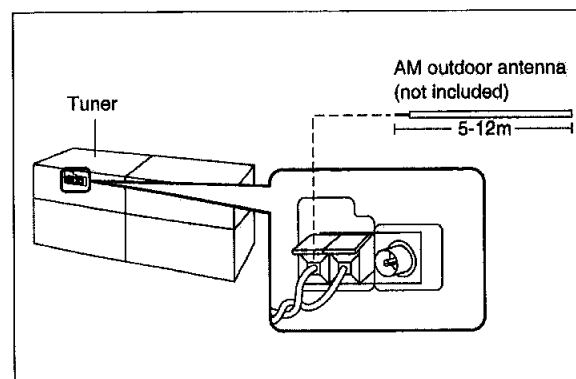

7 Operation Checks and Component Replacement Procedures

- NOTE**
1. This section describes procedures for checking the operation of the major printed circuit boards and replacing the main components.
 2. For reassembly after operation checks or replacement, reverse the respective procedures. Special reassembly procedures are described only when required.
 3. Select item from the following index when checks or replacement are required.

● Contents

■ Checking Procedures for each P.C.B.

1. Checking for the power supply P.C.B. and speaker terminal P.C.B..
2. Checking for the operation P.C.B..
3. Checking for the main P.C.B..

■ Main Component Replacement Procedures

1. Replacement for the power IC.

■ Checking Procedures for each P.C.B.

1. Checking for the power supply P.C.B. and speaker terminal P.C.B.

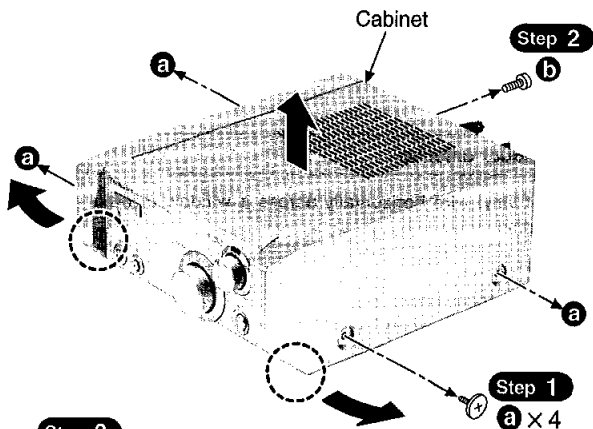

Step 3
Spreading the both front tails indicated with (○) of cabinet a small amount, lift up and remove the cabinet in the direction of arrow.

- Check the power supply P.C.B. and speaker terminal P.C.B. as shown below.

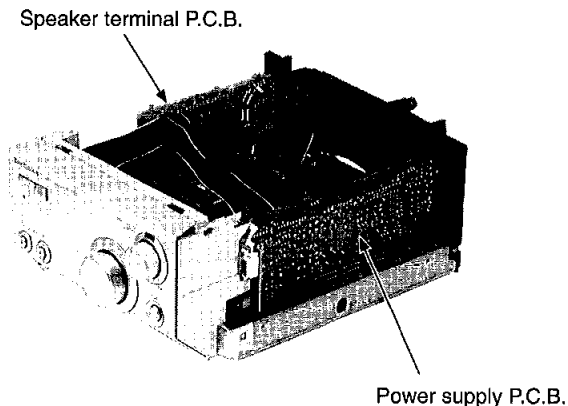

2. Checking for the operation P.C.B.

- Follow the **Step 1** ~ **Step 3** of the item 1 in checking procedure for each P.C.B..

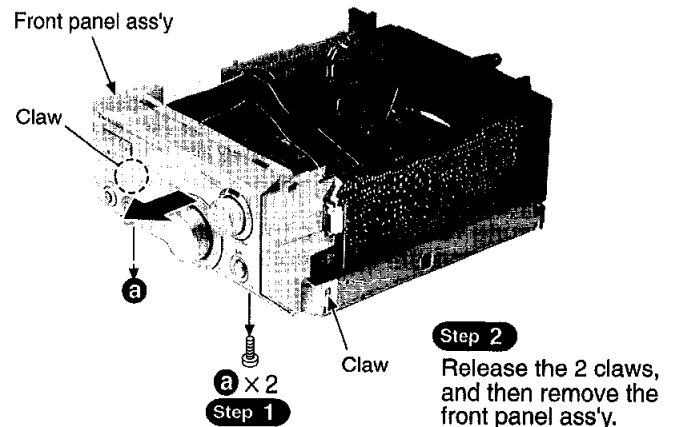

Step 2
Release the 2 claws, and then remove the front panel ass'y.

- Check the operation P.C.B. as shown below.

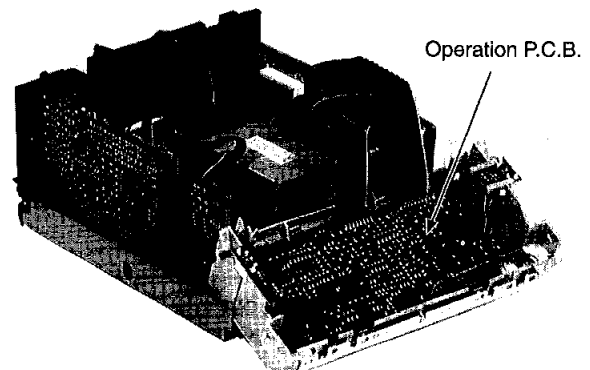

3. Checking for the main P.C.B.

- Follow the **Step 1** ~ **Step 3** of the item 1 in checking procedure for each P.C.B..
- Follow the **Step 1**, **Step 2** of the item 2 in checking procedure for each P.C.B..

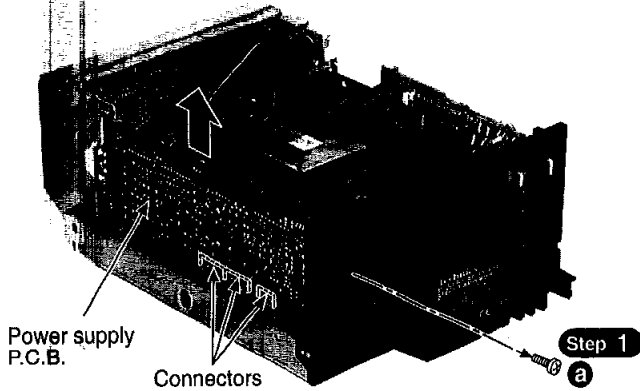

Step 2
Remove the power supply P.C.B. upward with care to prevent damage to the connectors.

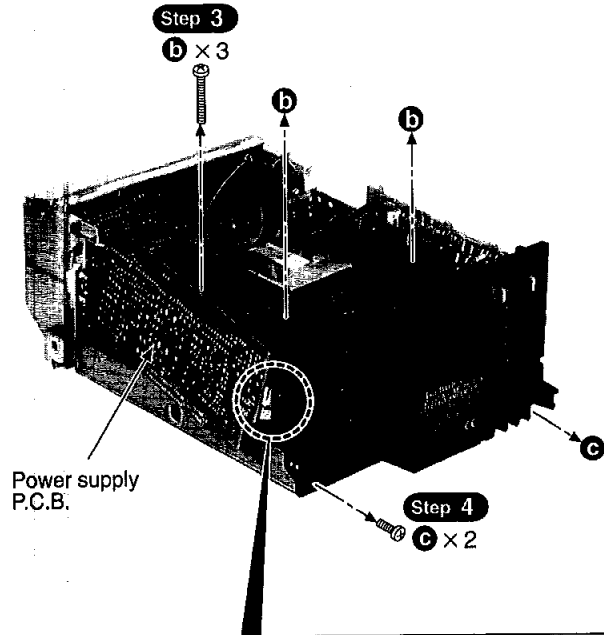

■ Notice for installation of power supply P.C.B.

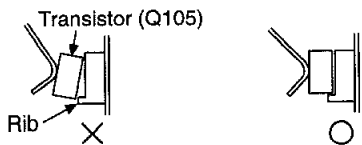

1. Use care that the transistor (Q105) is not located on the rib as shown above.
2. Apply the compound grease (No. RFKX0002 or equivalent material) on the back side of transistor (Q105).
3. Use care to prevent applying the grease on the lead wire or other parts.

Step 5

Reinstall the power supply P.C.B. to the main P.C.B..

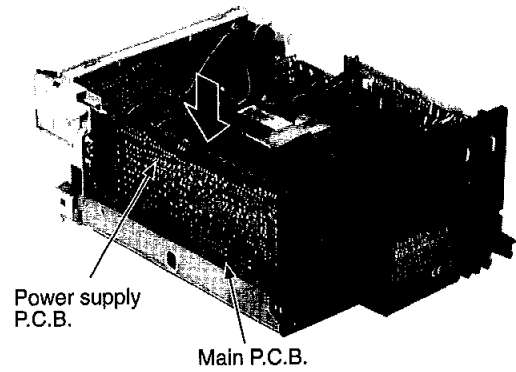

Step 6

Lift up the main P.C.B. a small amount to release 2 ribs. More, release the 2 claws with lifting the rear panel vertical.

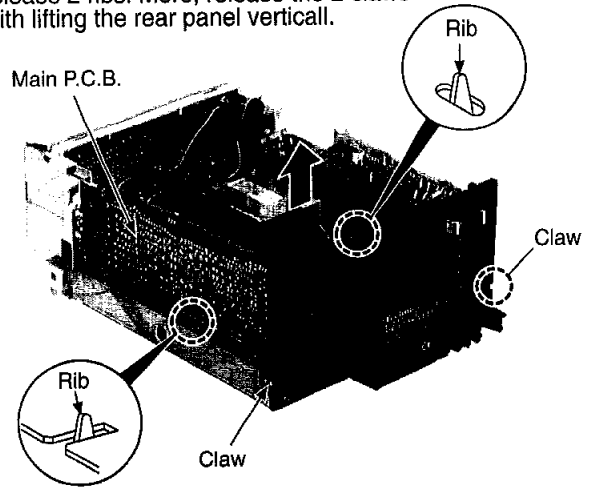

• Check the main P.C.B. as shown below.

Step 7

Raise the main P.C.B..

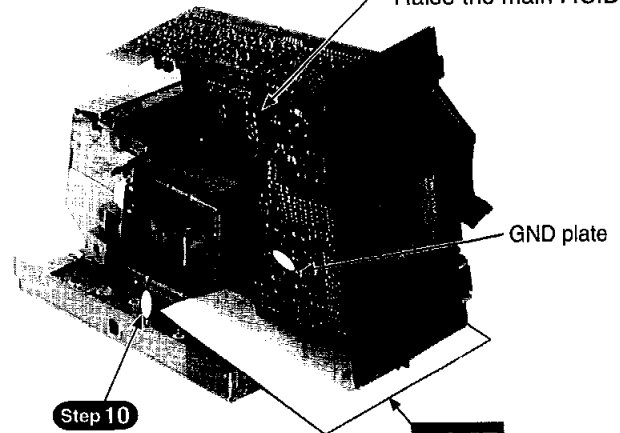

Step 10

Connect the lead wire.

NOTE

Insulate main P.C.B. with insulation material to avoid short-circuit.

■ Main Component Replacement Procedures

1. Replacement for the power IC

- Follow the **Step 1** ~ **Step 3** of the item 1 in checking procedure for each P.C.B..
- Follow the **Step 1** , **Step 2** of the item 2 in checking procedure for each P.C.B..
- Follow the **Step 1** ~ **Step 4** of the item 3 in checking procedure for each P.C.B..

Step 1

Remove the 2 connectors.

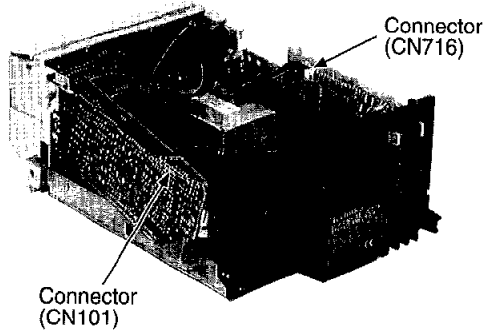

Step 2

Lift up the main P.C.B. a small amount to release 2 ribs. More, release the 2 claws with lifting the rear panel verticall.

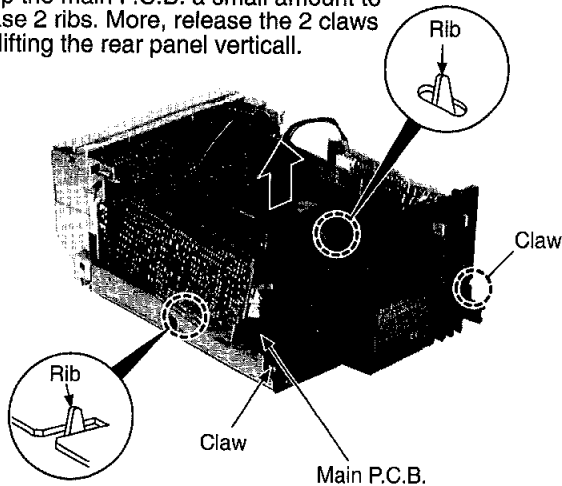

Step 5

Lift up the speaker terminal P.C.B..

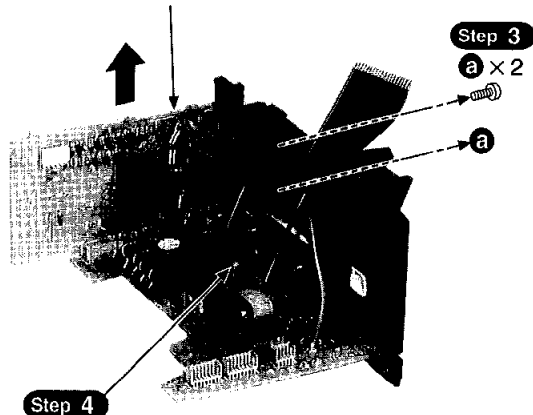

Step 4

Remove the flat cable from connector (CP701).

Power IC (IC502)
[LM1876TF]

Power IC (IC501)
[RSN35H1]

Step 7

Remove the holder.

Step 6

b x 3

NOTE

When mounting the power IC apply silicone compound (RFKX0002) to the rear side of power IC.

Step 8

Unsolder the terminals of power IC.

8 Power Source ON/OFF and Signal Check

To operate this unit SE-HD505 normally, it is necessary for connecting with the unit ST-HD505.

When operating the unit SE-HD505, be sure to connect the unit ST-HD505 by connection cable.

1. Connect with the Tuner (ST-HD505). (As shown in Fig. 1)
2. Connect the AC mains lead to Amplifier (SE-HD505). (As shown in Fig. 1)

3. Connect the speakers to speaker terminal. (As shown in Fig. 1)
4. Turn on the power of the Amplifier (SE-HD505).
5. Press INPUT SELECTOR to select the external source (EXT) of the Amplifier (SE-HD505).
6. Input a sound signal to external input terminal of Tuner (ST-HD505), and confirm to be outputted from the speaker.

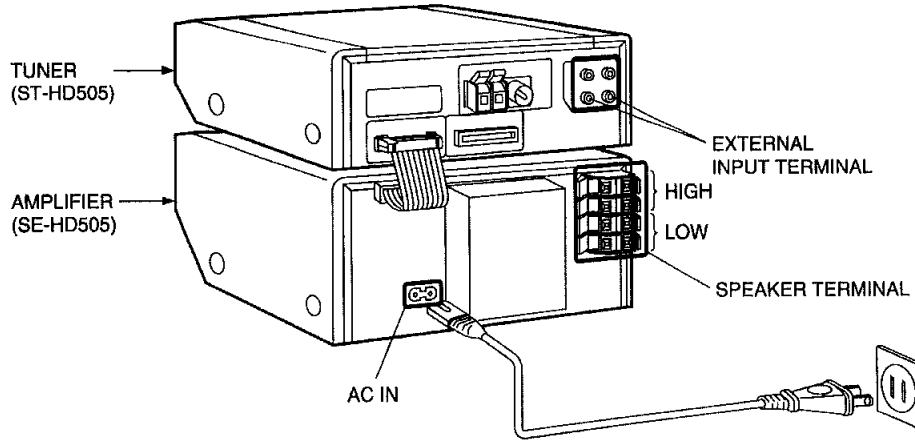

Fig. 1

9 Schematic Diagram Notes



9.1. Type Illustration of IC's, Transistors and Diodes

<p>M5218AFPE3</p>	<p>RSN35H1</p>	<p>LM1876TF</p>	<p>2SA1309ATA 2SC3311ATA UN4115TA</p>	<p>2SB621AQRSTA 2SD592AQRSTA</p>
<p>2SC3940AQSTA</p>	<p>2SD2374PQAU</p>	<p>2SD2144STA</p>	<p>MA165TA</p>	<p>MA4051MTA MA4062MTA MA4082MTA</p>
<p>MA4075MTA MA4110MTA MA4120MTA MA4150MTA MA4160MTA MA4240MTA</p>	<p>MA719TA</p>	<p>1N5402BF RL1N4003N02</p>	<p>SLR-325VC</p>	<p>LMW9A8BYB0A1</p>

9.2. Schematic Diagram Notes

- This schematic diagram may be modified at any time with the development of new technology.

Notes:

- **S301:** Power "STANDBY  / ON" switch in "ON" position.
- **S302:** Eco mode switch in "OFF" position.
- **S303:** Input selector() switch.
- **S308:** Input selector () switch .
- **S308:** BLFS/-DEMO switch.
- **VR301:** Volume V.R.
- **VR401:** Fine tweeter control V.R.
- Indicated voltage values are the standard values for the unit measured by the DC electronic circuit tester (high-impedance)with the chassis taken as standard. Therefore, there may exist some errors in the voltage values, depending on the internal impedance of the DC circuit tester.

No mark: Power ON

- Important safety notice:

Components identified by  mark have special characteristics important for safety.

Furthermore, special parts which have purposes of fire-retardant (resistors), high-quality sound (capacitors), low-noise (resistors), etc. are used.

When replacing any of components, be sure to use only manufacture's specified parts shown in the parts list.

- **Caution!**

IC and LSI are sensitive to static electricity.

Secondary trouble can be prevented by taking care during repair.

Cover the parts boxes made of plastics with aluminum foil.

Ground the soldering iron.

Put a conductive mat on the work table.

Do not touch the legs of IC or LSI with the fingers directly.

- **Voltage and signal lines**

 : Positive voltage line

 : Negative voltage line

 : Source signal line

CAUTION: FOR CONTINUED PROTECTION AGAINST FIRE HAZARD, REPLACE ONLY WITH SAME TYPE 6A125V FUSE.

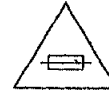

RISK OF FIRE-REPLACE FUSE AS MARKED.

FUSE CAUTION

 This symbol located near the fuse indicates that the fuse used is slow operating type. For continued protection against fire hazard, replace with same type fuse. For fuse rating, refer to the marking adjacent to the symbol.

 Ce symbole indique que le fusible utilisé est à trot. Pour une protection permanente, n' utiliser que des fusibles de même type. Ce dernier est indiqué là où le présent symbole est apposé.

10 Schematic Diagram

A POWER SUPPLY CIRCUIT

———> : POSITIVE VOLTAGE LINE
 - - - -> : NEGATIVE VOLTAGE LINE ⇨ : SOURCE SIGNAL LINE

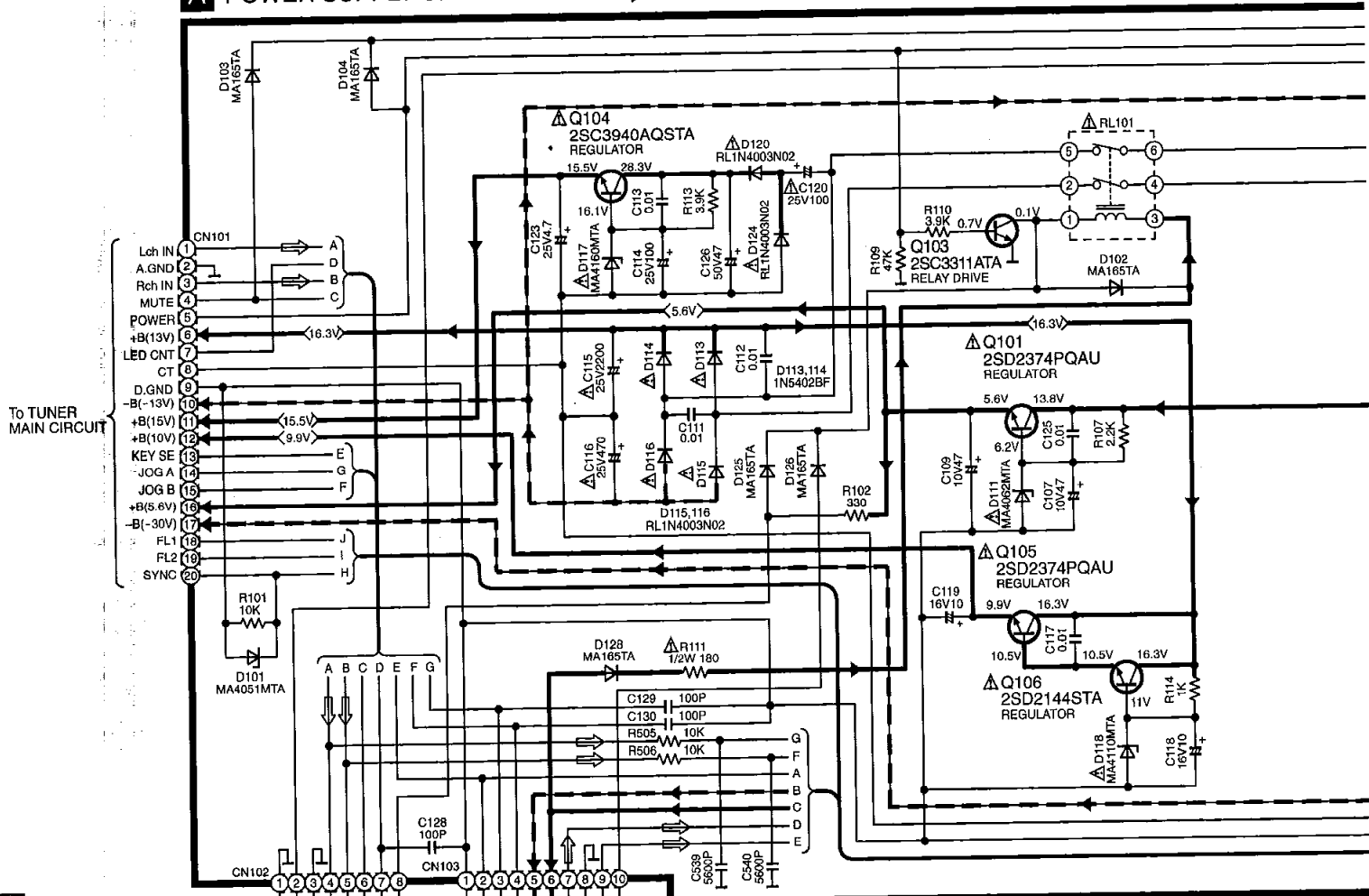

B OPERATION CIRCUIT

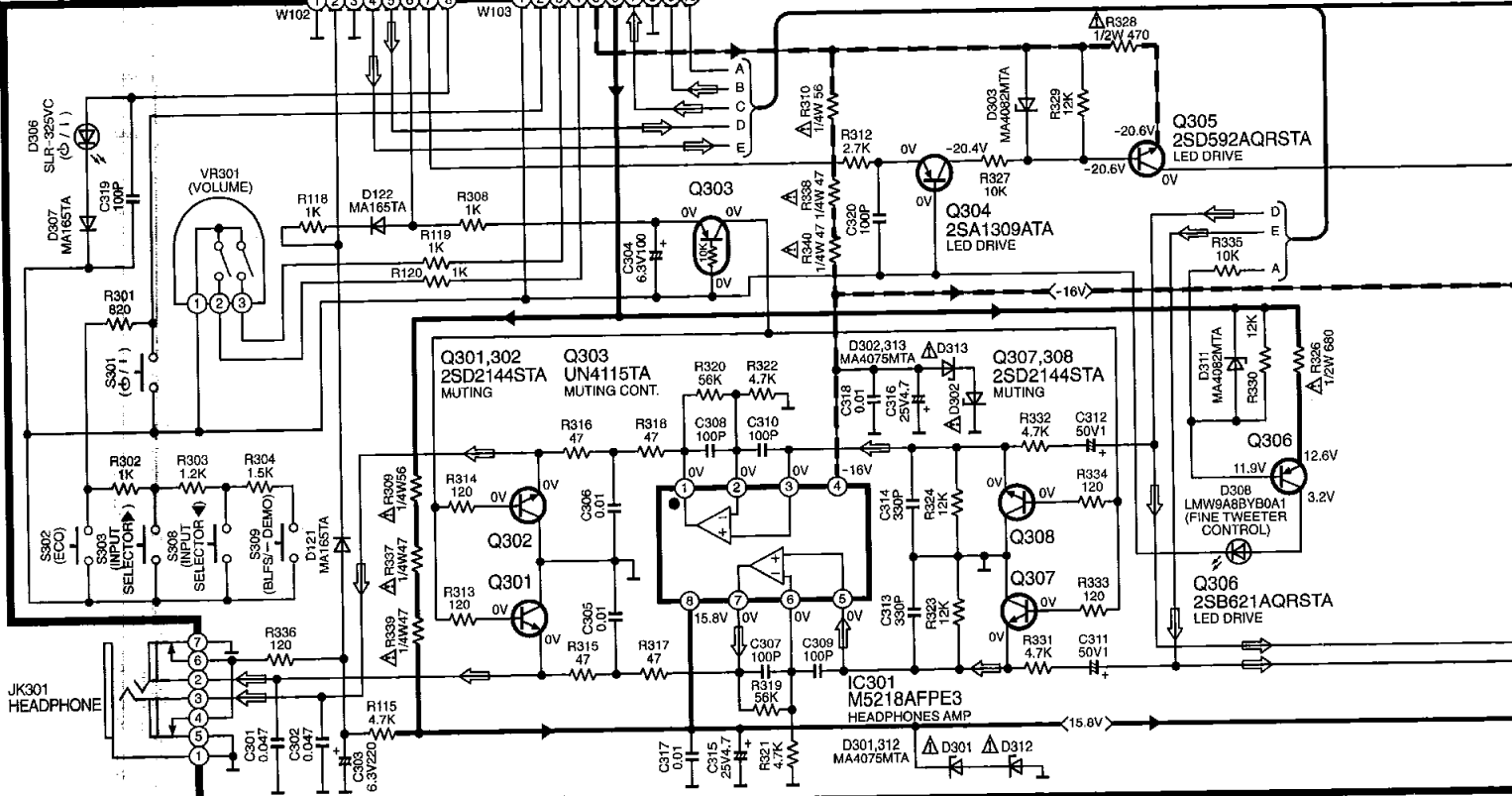

—●— : POSITIVE VOLTAGE LINE
 -●- : NEGATIVE VOLTAGE LINE ⇨ : SOURCE SIGNAL LINE

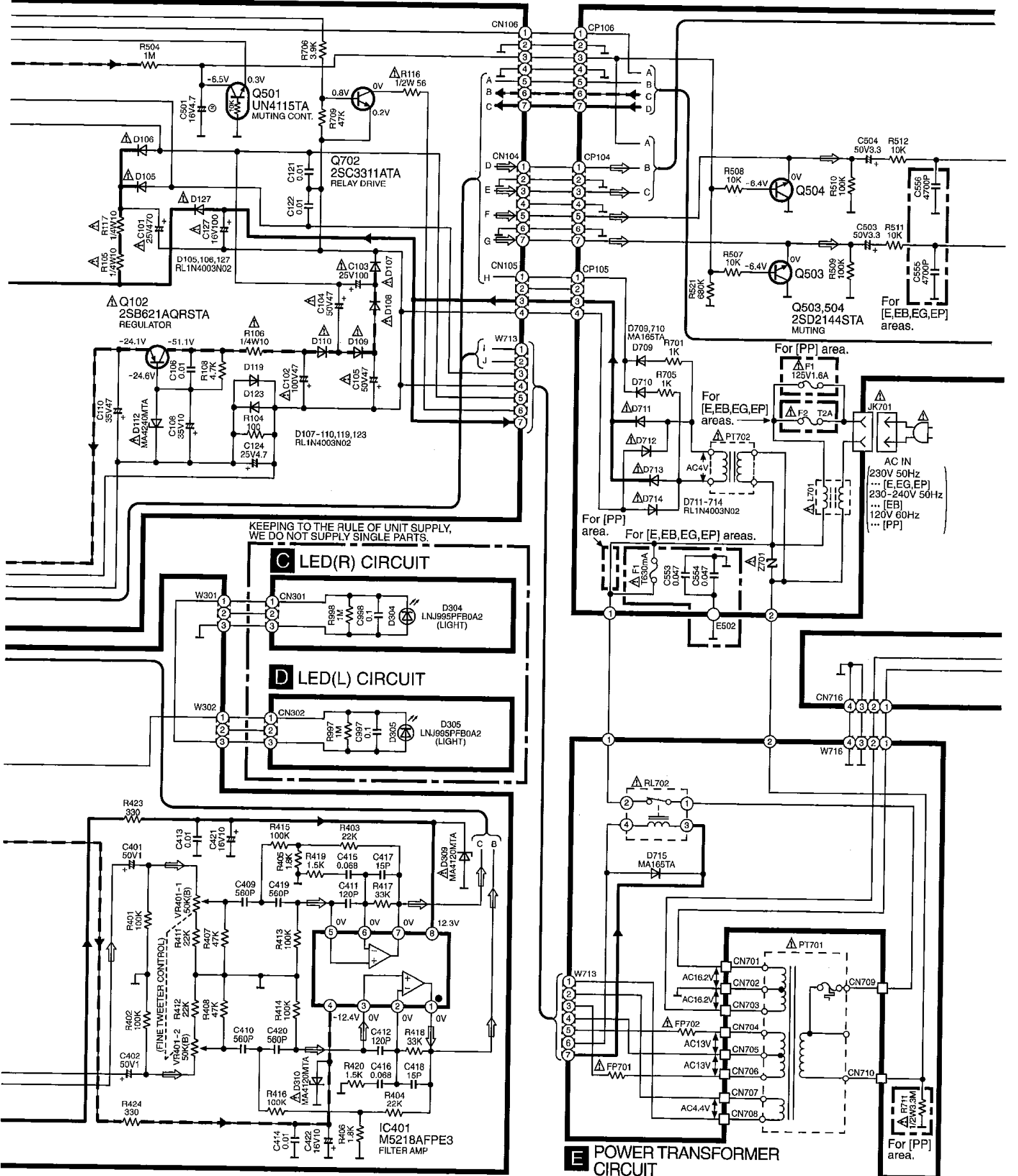

KEEPING TO THE RULE OF UNIT SUPPLY,
 WE DO NOT SUPPLY SINGLE PARTS.

F MAIN CIRCUIT

→ : POSITIVE VOLTAGE LINE ← : NEGATIVE VOLTAGE LINE ⇨ : SOURCE SIGNAL LINE

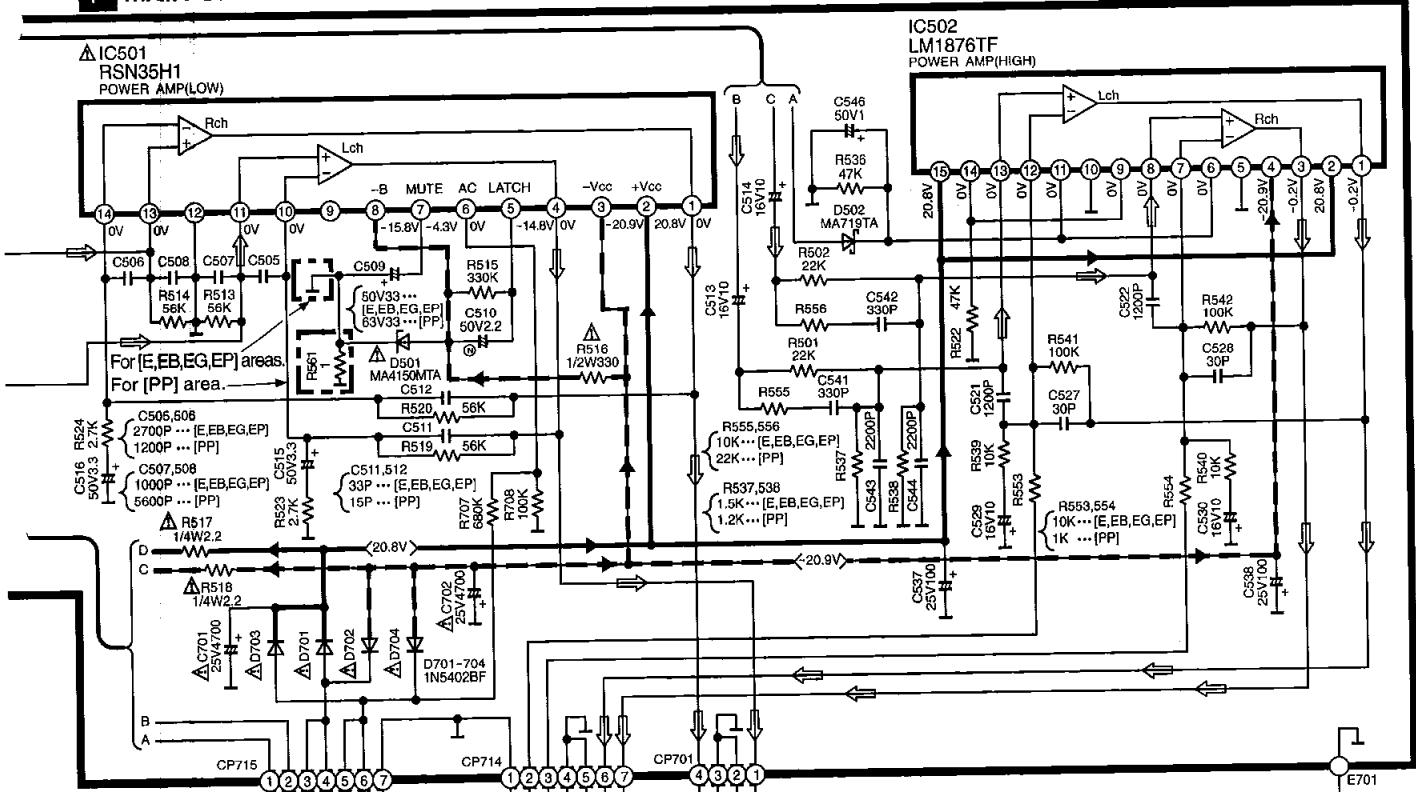

G SPEAKER TERMINAL CIRCUIT

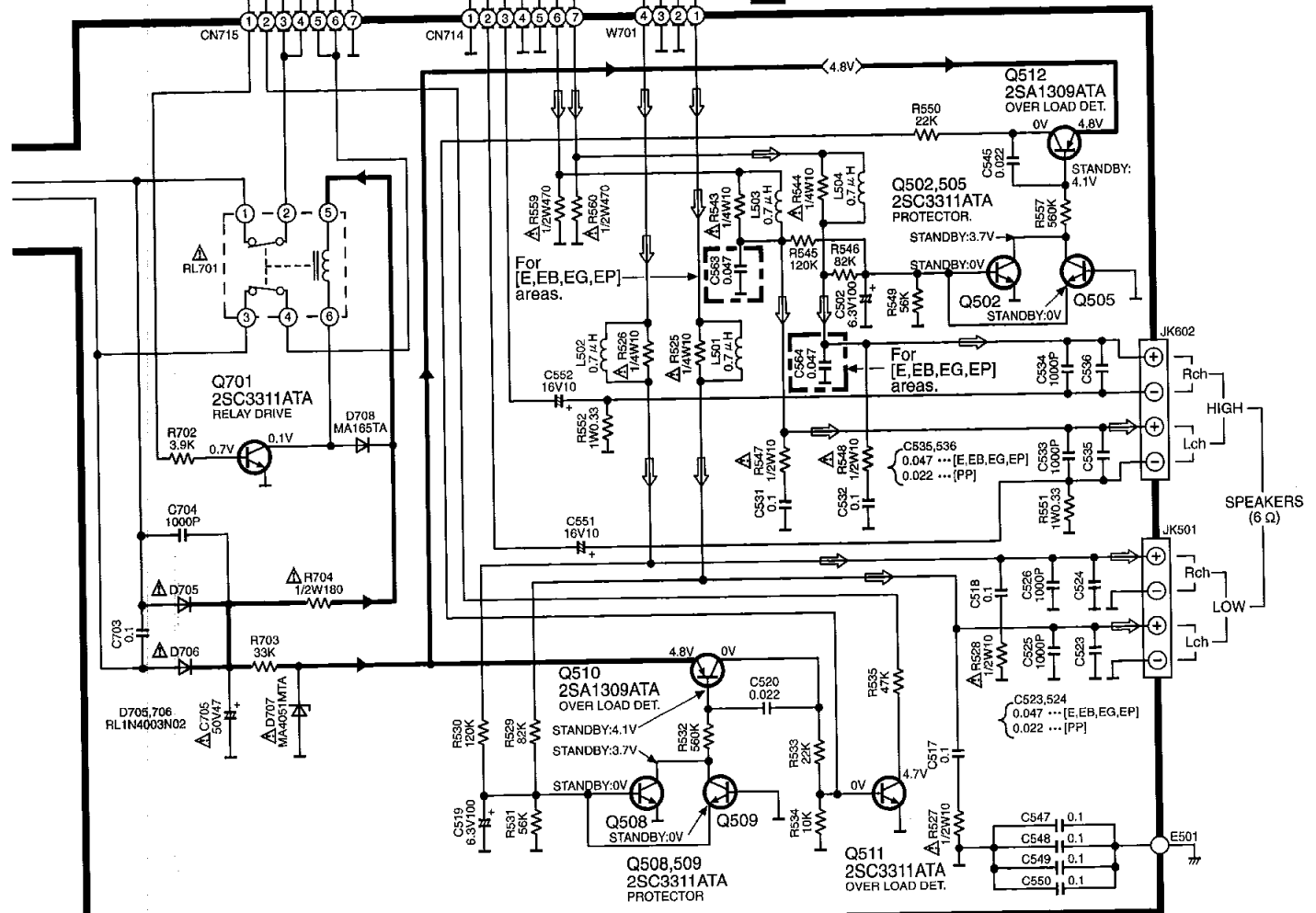

11 Printed Circuit Board Diagram

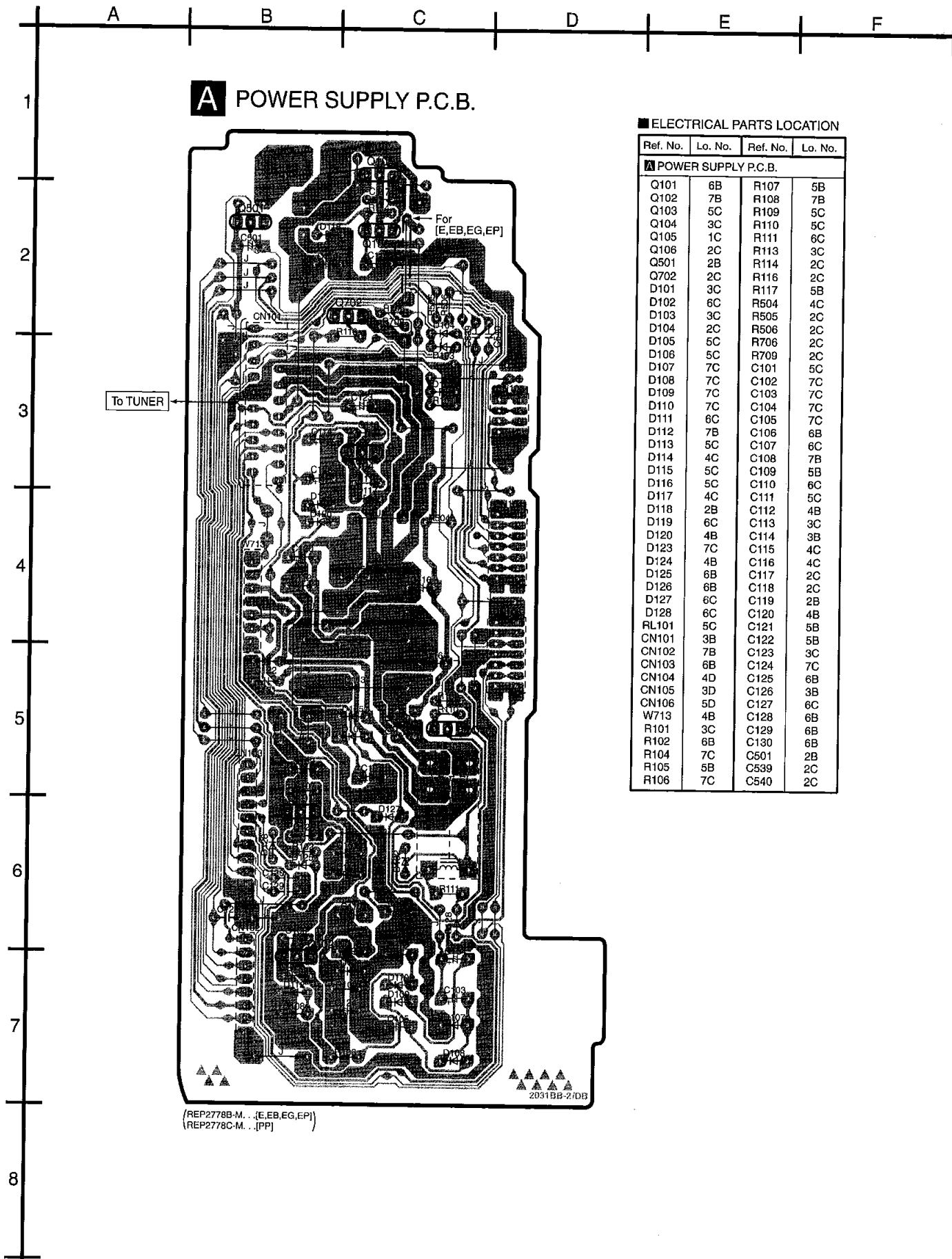

A POWER SUPPLY P.C.B.

■ ELECTRICAL PARTS LOCATION

Ref. No.	Lo. No.	Ref. No.	Lo. No.
▲ POWER SUPPLY P.C.B.			
Q101	6B	R107	5B
Q102	7B	R108	7B
Q103	5C	R109	5C
Q104	3C	R110	5C
Q105	1C	R111	6C
Q106	2C	R113	3C
Q501	2B	R114	2C
Q702	2C	R116	2C
D101	3C	R117	5B
D102	6C	R504	4C
D103	3C	R505	2C
D104	2C	R506	2C
D105	5C	R706	2C
D106	5C	R709	2C
D107	7C	C101	5C
D108	7C	C102	7C
D109	7C	C103	7C
D110	7C	C104	7C
D111	6C	C105	7C
D112	7B	C106	6B
D113	5C	C107	6C
D114	4C	C108	7B
D115	5C	C109	5B
D116	5C	C110	6C
D117	4C	C111	5C
D118	2B	C112	4B
D119	6C	C113	3C
D120	4B	C114	3B
D123	7C	C115	4C
D124	4B	C116	4C
D125	6B	C117	2C
D126	6B	C118	2C
D127	6C	C119	2B
D128	6C	C120	4B
RL101	5C	C121	5B
CN101	3B	C122	5B
CN102	7B	C123	3C
CN103	6B	C124	7C
CN104	4D	C125	6B
CN105	3D	C126	3B
CN106	5D	C127	6C
W713	4B	C128	6B
R101	3C	C129	6B
R102	6B	C130	6B
R104	7C	C501	2B
R105	5B	C539	2C
R106	7C	C540	2C

(REP2778B-M...[E,EB,EG,EP])
(REP2778C-M...[PP])

2931BB-2/DB

A | B | C | D | E | F

1
2
3
4
5
6
7
8

B OPERATION P.C.B.

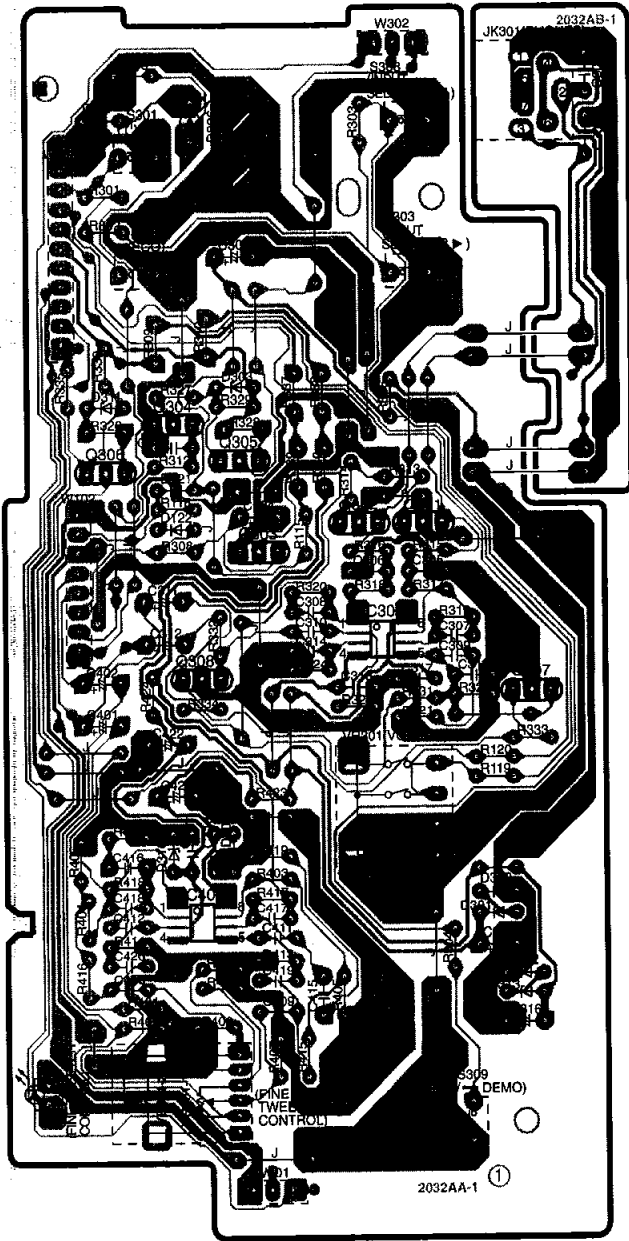

(REP2779A-S)

ELECTRICAL PARTS LOCATION

Ref. No.	Lo. No.	Ref. No.	Lo. No.	Ref. No.	Lo. No.
B OPERATION P.C.B.					
IC301	4C	R309	3B	R417	5B
IC401	5B	R310	3B	R418	5A
Q301	3C	R312	3B	R419	5B
Q302	3B	R313	3C	R420	5A
Q303	4B	R314	3B	R423	5B
Q304	3B	R315	4C	R424	4B
Q305	3B	R316	4C	C301	1D
Q306	3A	R317	4C	C302	2D
Q307	4C	R318	4C	C303	2B
Q308	4B	R319	4C	C304	3B
D121	3B	R320	4B	C305	4C
D122	3B	R321	4C	C306	4C
D301	5C	R322	4B	C307	4C
D302	5C	R323	4C	C308	4B
D303	3B	R324	4B	C309	4C
D306	2B	R326	3A	C310	4B
D307	2A	R327	3B	C311	4B
D308	6A	R328	3B	C312	4B
D309	5B	R329	3B	C313	4C
D310	5B	R330	3A	C314	4B
D311	3A	R331	4C	C315	5C
D312	5C	R332	4B	C316	6C
D313	6C	R333	4C	C317	4C
VR301	5C	R334	4B	C318	4B
VR401	6B	R335	3A	C319	1A
S301	2A	R336	3C	C320	3B
S302	2A	R337	3B	C401	4A
S303	2C	R338	3B	C402	4A
S308	2C	R339	3B	C409	6B
S309	6C	R340	3B	C410	5A
W102	4A	R401	6A	C411	5B
W103	2A	R402	6A	C412	5A
W301	6B	R403	5B	C413	5B
W302	1C	R404	5A	C414	5B
JK301	1C	R405	6B	C415	6B
R115	3B	R406	5A	C416	5A
R118	3B	R407	6B	C417	5B
R119	5C	R408	6B	C418	5A
R120	4C	R411	5B	C419	5B
R301	2A	R412	5B	C420	5A
R302	2A	R413	5B	C421	5B
R303	2B	R414	5A	C422	4B
R304	5C	R415	6B		
R308	4B	R416	5A		
C LED (R) P.C.B.					
D304	8B	R998	8B		
CN301	8C	C998	8B		
D LED (L) P.C.B.					
D305	8D	R997	8E		
CN302	8E	C997	8E		

[Keeping to the rule of unit supply, we do not supply single parts.]

C LED(R) P.C.B.

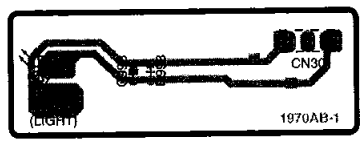

(REP2684A-S)

D LED(L) P.C.B.

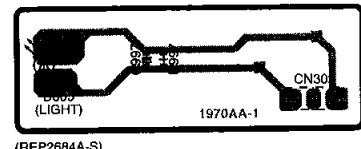

(REP2684A-S)

A B C D E F

1
2
3
4
5
6
7
8

F MAIN P.C.B.

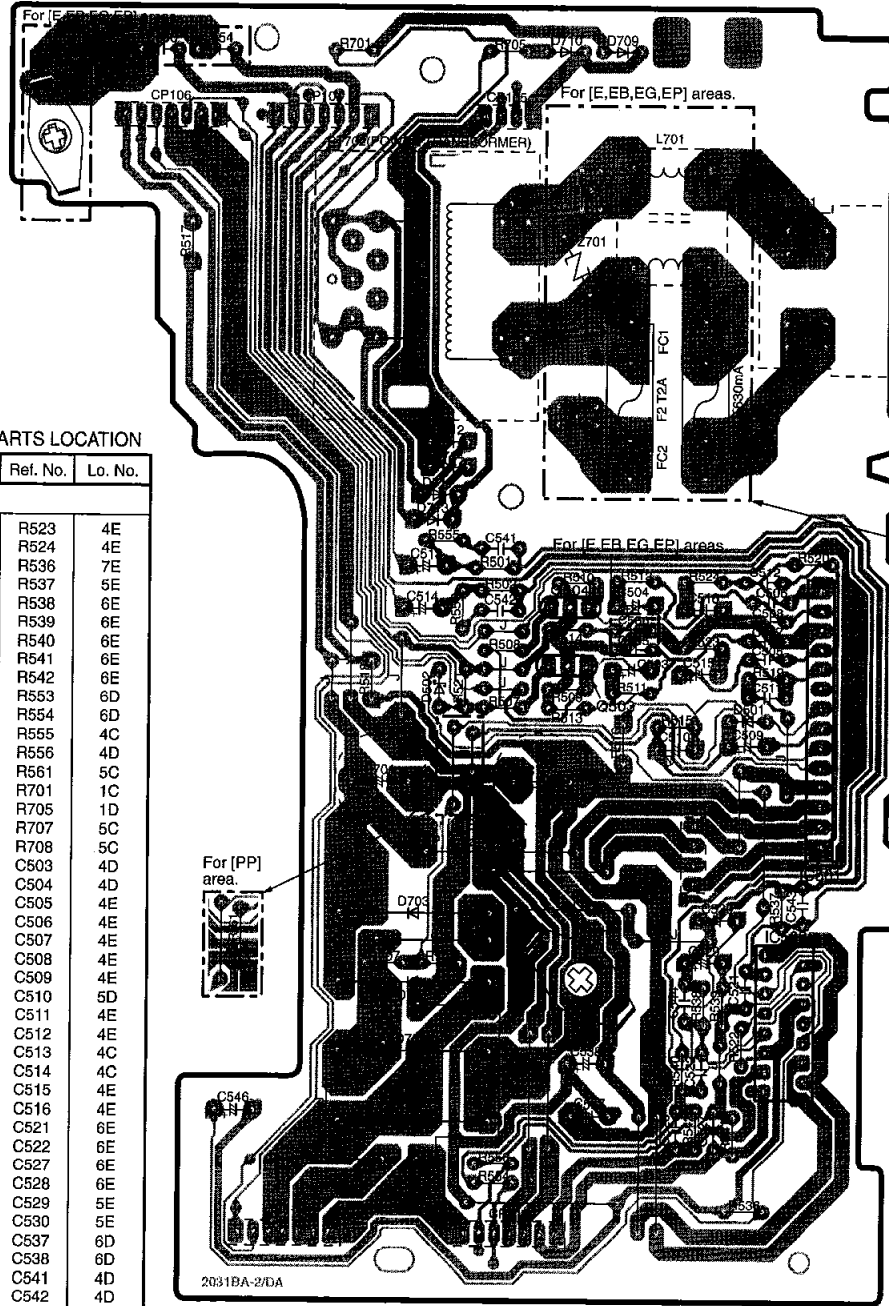

AC IN
(230V 50Hz---[E,EG,EP])
(230-240V 50Hz---[EB])
(120V 60Hz-----[PP])

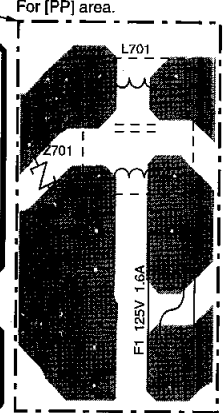

ELECTRICAL PARTS LOCATION

Ref. No.	Lo. No.	Ref. No.	Lo. No.
MAIN P.C.B.			
IC501	4E	R523	4E
IC502	6E	R524	4E
Q503	4D	R536	7E
Q504	4D	R537	5E
D501	4E	R538	6E
D502	4C	R539	6E
D701	6C	R540	6E
D702	6C	R541	6E
D703	5C	R542	6E
D704	6C	R553	6D
D709	1D	R554	6D
D710	1D	R555	4C
D711	3C	R556	4D
D712	3C	R561	5C
D713	3C	R701	1C
D714	3C	R705	1D
L701	2D,4F	R707	5C
Z701	2D,4F	R708	5C
F1	3E,5F	C503	4D
F2	3D	C504	4D
FC1	3D,5F	C505	4E
FC2	3D,5F	C506	4E
FC3	3E	C507	4E
FC4	3E	C508	4E
CP104	2C	C509	4E
CP105	2D	C510	5D
CP106	2B	C511	4E
CP701	5E	C512	4E
CP714	7D	C513	4C
CP715	7C	C514	4C
JK701	2E	C515	4E
E502	2B	C516	4E
E701	5D	C521	6E
PT702	2C	C522	6E
R501	4D	C527	6E
R502	4D	C528	6E
R507	4D	C529	5E
R508	4D	C530	5E
R509	4D	C537	6D
R510	4D	C538	6D
R511	4D	C541	4D
R512	4D	C542	4D
R513	4D	C543	5E
R514	4D	C544	6E
R515	4D	C546	6C
R516	4D	C553	1B
R517	2B	C554	1B
R518	4C	C555	4D
R519	4E	C556	4D
R520	4E	C701	5C
R521	4D	C702	5D
R522	6E		

2031BA-2/DA
(REP2778B-M... [E,EB,EG,EP])
(REP2778C-M... [PP])

A B C D E F

1
2
3
4
5
6
7
8

E POWER TRANSFORMER P.C.B.
For [E,EB,EG,EP] areas.

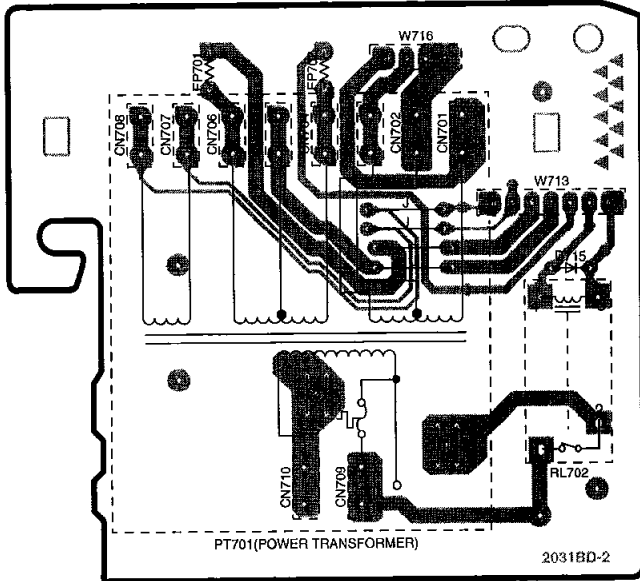

(REP2778B-M)

ELECTRICAL PARTS LOCATION

Ref. No.	Lo. No.	Ref. No.	Lo. No.
POWER TRANS. P.C.B.			
For [E,EB,EG,EP] areas.			
D715	2D	CN705	2C
PT701	3C	CN706	2B
FP701	2B	CN707	2B
FP702	2C	CN708	2B
RL702	3D	CN709	3C
CN701	2C	CN710	3C
CN702	2C	W713	2D
CN703	2C	W716	2C
CN704	2C		
POWER TRANS. P.C.B.			
For [PP] area.			
D715	6D	CN705	5C
PT701	6C	CN706	5B
FP701	5B	CN707	5B
FP702	5C	CN708	5B
RL702	7D	CN709	7C
CN701	5C	CN710	7C
CN702	5C	W713	6D
CN703	5C	W716	5C
CN704	5C	R711	6B

E POWER TRANSFORMER P.C.B.
For [PP] area.

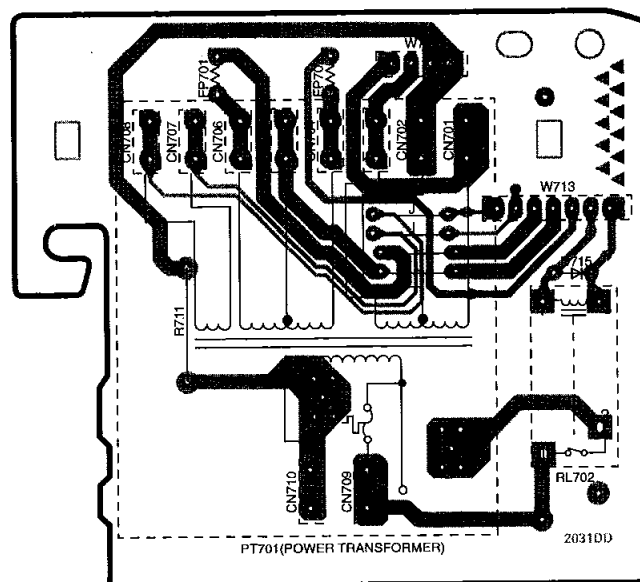

(REP2778C-M)

G SPEAKER TERMINAL P.C.B.

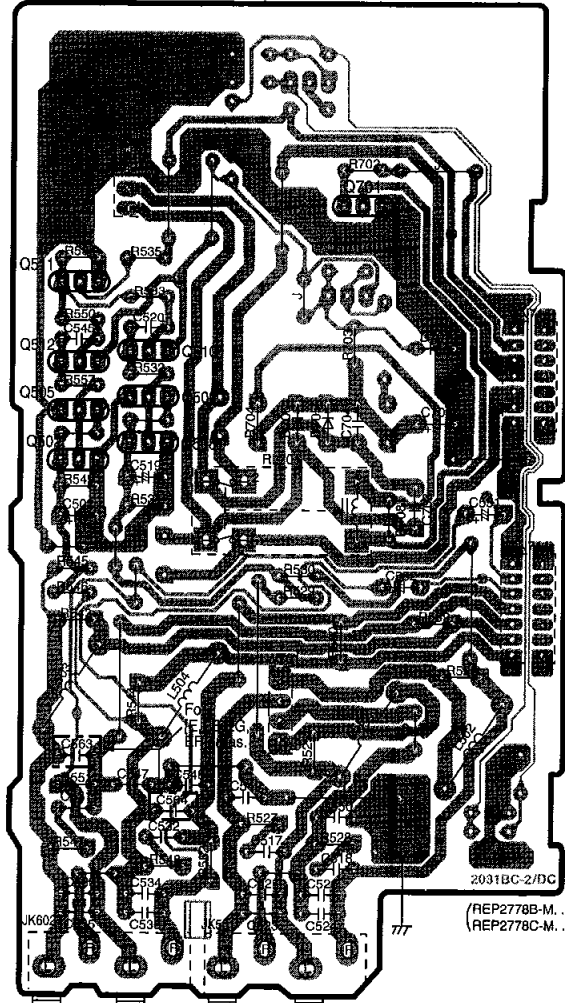

(REP2778B-M...[E,EB,EG,EP])
(REP2778C-M...[PP])

■ ELECTRICAL PARTS LOCATION

Ref. No.	Lo. No.	Ref. No.	Lo. No.
G SPEAKER TERMINAL P.C.B.			
Q502	3A	R547	5A
Q505	3A	R548	5B
Q508	3B	R549	4A
Q509	3B	R550	3A
Q510	3B	R551	5A
Q511	3A	R552	5B
Q512	3A	R557	3A
Q701	2B	R559	4C
D705	3B	R560	4B
D706	3B	R702	2B
D707	3C	R703	3B
D708	4C	R704	3B
L501	5C	C502	4A
L502	5C	C517	5B
L503	4A	C518	5B
L504	5B	C519	4B
RL701	4B	C520	3B
CN714	4C	C523	6B
CN715	3C	C524	6B
CN716	2A	C525	5B
W701	5B	C526	5B
JK501	6B	C531	5A
JK602	6A	C532	5B
E501	5C	C533	5A
R525	5B	C534	5B
R526	4C	C535	6A
R527	5B	C536	6B
R528	5B	C545	3A
R529	4B	C547	5A
R530	4B	C548	5B
R531	4B	C549	5B
R532	3B	C550	5B
R533	3B	C551	4C
R534	3A	C552	4C
R535	3B	C563	5A
R543	4A	C564	5B
R544	5A	C703	4C
R545	4A	C704	3B
R546	4A	C705	3C

12 Block Diagram

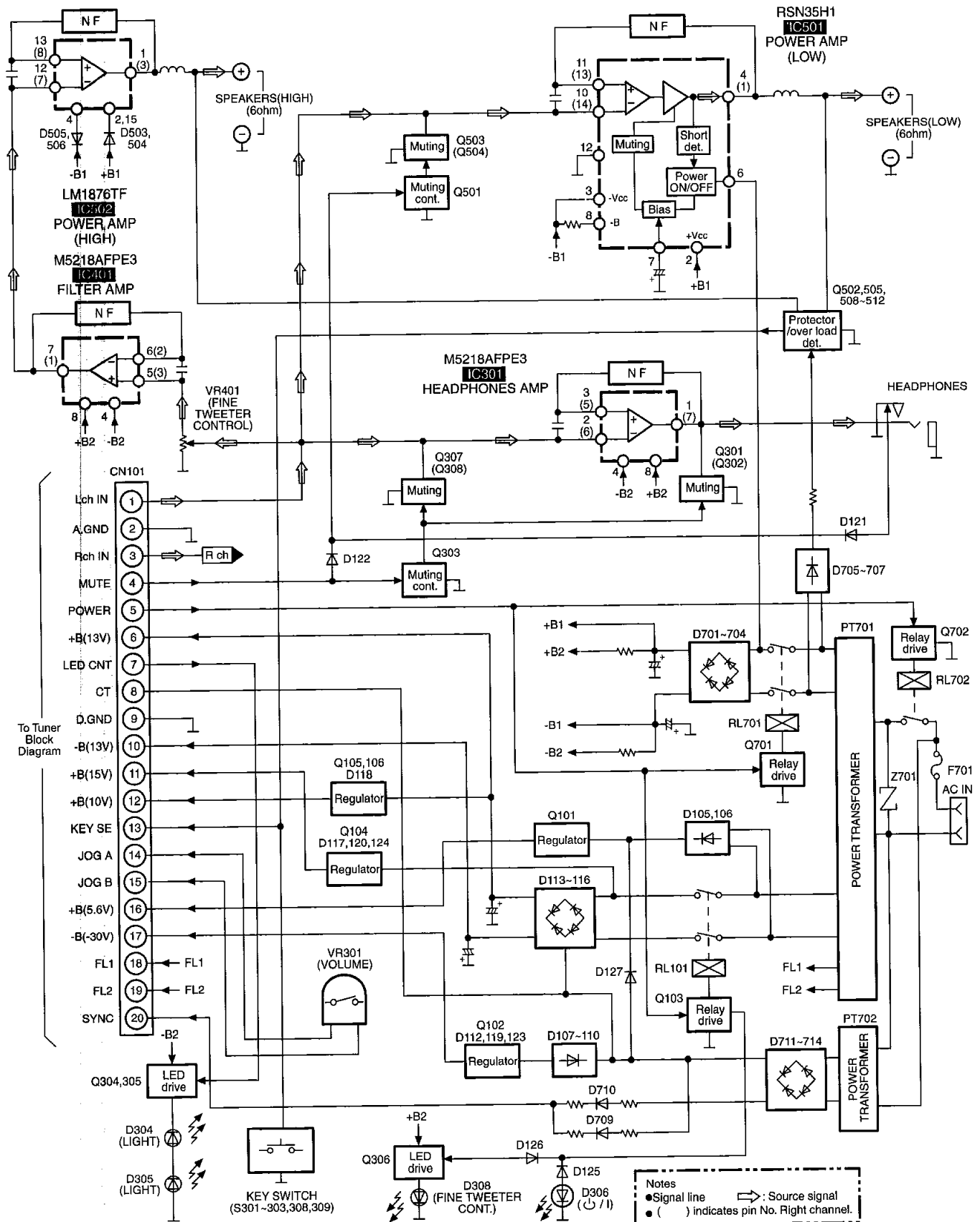

13 Wiring Connection Diagram

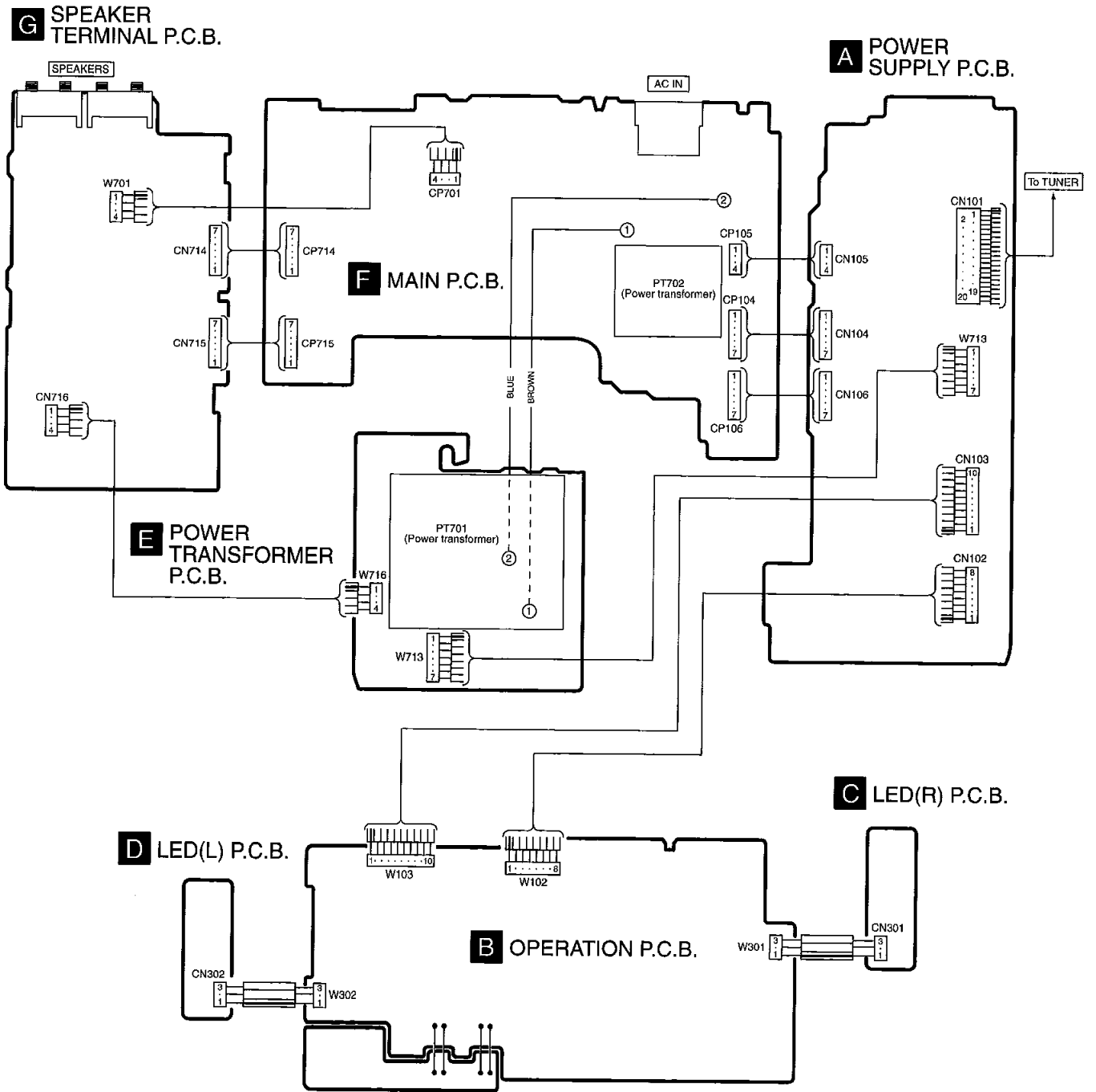

14 Replacement Parts List

Notes:

* Important safety notice:

Components identified by Δ mark have special characteristics important for safety.

Furthermore, special parts which have purposes of fire-retardant (resistors), high-quality sound (capacitors), low-noise (resistors), etc. are used.

When replacing any of components, be sure to use only manufacture's specified parts shown in the parts list.

* The parenthesized indications in the Remarks columns specify the areas.

Parts without these indications can be used for all areas.

* Remote Control Ass'y: Supply period for three years from terminal of production.

* Capacity values are in microfarads (uF) unless specified otherwise, P=Pico-farads(pF), F=Farads (F)

* Resistance values are in ohms, unless specified otherwise, 1K=1,000 (OHM), 1M=1,000K (OHM)

* "<IA>, <IB>, <IC>, <ID>, <IE>, <IF>, <IG>" marks in Remarks indicate languages of instruction manuals.

[<IA>: Spanish/Swedish, <IB>: German/Italian/French, <IC>: Dutch/Danish, <ID>: English, <IE>: Czech/Polish, <IF>: English, <IG>: Canadian French]

*The marking (RTL) indicates that the Retention Time is limited for this item. After the discontinuation of this assembly in production, the item will continue to be available for a specific period of time. The retention period of availability is dependant on the type of assembly, and in accordance with the laws governing part and product retention. After the end of this period, the assembly will no longer be available.

Ref. No.	Part No.	Part Name & Description	Pcs	Remarks
1	RHD30007-S	SCREW	4	
2	RGK0972-1S	SIDE PANEL (L)	1	
3	RGK0973-1S	SIDE PANEL (R)	1	
4	XTBS3+8JFZ1	SCREW	12	
5	RGL0394-Q	PANEL LIGHT (L)	1	
6	RGL0395-Q	PANEL LIGHT (R)	1	
7	XTBS26+8J	SCREW	5	
8	RKM0364B-1S	CABINET	1	
9	XTB3+8JFZ	SCREW	3	
10	RGH0153B-K	NAME PLATE	1	(E,EG)
10	RGH0153C-K	NAME PLATE	1	(EB)
10	RGH0153D-K1	NAME PLATE	1	(EP)
10	RGH0153E-K1	NAME PLATE	1	(PP)
11	XTBS3+10JFZ1	SCREW	1	
12	RGL0393-Q	PANEL LIGHT	1	
13	RGL0431-Q	MD INDICATOR	1	
14	XTB3+20JFZ	SCREW	3	
15	XTW3+15T	SCREW	3	
16	RGW0303-S	KNOB CONTROL	1	
17	REP2684A-S	LED L R P.C.B.	1	
18	RGG0161B-S	FRONT PANEL	1	(E EB EG EP)
18	RGG0161C-S	FRONT PANEL	1	(PP)
19	RGF0699A-S	SUB PANEL	1	
20	RHN90001	NUT	2	
21	RGW0277-1S	KNOB VOLUME	1	
22	RGU1716-S	BUTTON INPUT	1	
23	RHD26016	SCREW	1	
24	XTB3+5JFZ	SCREW	4	

Ref. No.	Part No.	Part Name & Description	Pcs	Remarks
25	RKA0098-K	FOOT	4	
26	XTB3+12FFZ	SCREW	1	
27	REX0962	FLAT CABLE (20P)	1	
28	RMZ0339	ZNR COVER	1	(E EB EG EP)
A1	RAK-HDA10WH	REMOTE CONT. TRANSMITTER	1	
A1-1	RKK0123-H	BATT. COVER (REMOTE CONT.)	1	
A5	RQA0117	WARRANTY CARD	1	(E EB EG EP)
A5	RQA0149	WARRANTY CARD (FOR U.S.A)	1	(PP)
A5	SQX7183	WARRANTY CARD (FOR CANADA)	1	(PP)
A6	REE0499	SPEAKER CORD	2	
A7	RJA0019-X	AC POWER SUPPLY CORD	1	(E EG EP)
Δ				
A7	RJA0053-2X	AC POWER SUPPLY CORD	1	(EB)
Δ				
A7	RJA0065-K	AC POWER SUPPLY CORD	1	(PP)
Δ				
A8	RQT4929-E	INSTRUCTION MANUAL	1	(E) <IA>
A8	RQT4930-D	INSTRUCTION MANUAL	1	(EG) <IB>
A8	RQT4931-H	INSTRUCTION MANUAL	1	(EG) <IC>
A8	RQT4932-B	INSTRUCTION MANUAL	1	(EB EP) <ID>
A8	RQT4933-R	INSTRUCTION MANUAL	1	(EP) <IE>
A8	RQT4934-P	INSTRUCTION MANUAL	1	(PP) <IF>
A8	RQT4935-C	INSTRUCTION MANUAL	1	(PP) <IG>
A9	RSA0021	AM LOOP ANTENNA	1	
A10	RSA0007	FM INDOOR ANTENNA	1	(E EB EG EP)
A10	RSA0006	FM INDOOR ANTENNA	1	(PP)
A11	REE0853	SPEAKER CORD	2	
A12	RQCB0169	SERVICENTER LIST	1	(E EB EG EP)
A12	RQCB0391	SERVI. LIST (FOR U.S.A.)	1	(PP)
A12	RQCB0832	SERVI. LIST (FOR CANADA)	1	(PP)
A13	RQCA0666	QUICK SET UP GUIDE	1	(EB)
A14	SJP9009	AC PLUG ADAPTOR	1	(EB)
C101	RCE1EM471BV	25V 470U	1	
Δ				
C102	ECA2AM470	100V 47U	1	
Δ				
C103	ECA1EM101	25V 100U	1	
Δ				
C104,05	ECA1HM470	50V 47U	2	
Δ				
C106	ECBT1E103ZF	25V 0.01U	1	
C107	RCE1AKA470BG	10V 47U	1	
C108	RCE1VKA100BG	35V 10U	1	
C109	RCE1AKA470BG	10V 47U	1	
C110	ECEALVKS470	35V 47U	1	
C111,12	ECKR1H103ZF5	50V 0.01U	2	
C113	ECBT1E103ZF	25V 0.01U	1	
C114	ECA1EM101	25V 100U	1	
C115	ECA1EM222	25V 2200U	1	
Δ				
C116	RCE1EM471BV	25V 470U	1	
Δ				
C117	ECBT1E103ZF	25V 0.01U	1	
C118,19	RCE1CKA100BG	16V 10U	2	
C120	ECA1EM101	25V 100U	1	
Δ				
C121,22	ECBT1E103ZF	25V 0.01U	2	
C123,24	ECEALEKS4R7	25V 4.7U	2	
C125	ECBT1E103ZF	25V 0.01U	1	
C126	ECA1HM470	50V 47U	1	

Ref. No.	Part No.	Part Name & Description	Pcs	Remarks
C127 △	ECEA1CK5101	16V 100U	1	
C128-30	ECBT1H101KB5	50V 100P	3	
C301,02	ECBT1H473ZF5	50V 0.047U	2	
C303	ECEA1AKS221	6.3V 220U	1	
C304	ECEA0JKS101	6.3V 100U	1	
C305,06	ECBT1E103ZF	25V 0.01U	2	
C307-10	ECBT1H101KB5	50V 100P	4	
C311,12	ECEA1HKS010	50V 1U	2	
C313,14	ECBT1H331KB5	50V 330P	2	
C315,16	ECEA1EKS4R7	25V 4.7U	2	
C317,18	ECBT1E103ZF	25V 0.01U	2	
C319,20	ECBT1H101KB5	50V 100P	2	
C401,02	ECEA1HKS010	50V 1U	2	
C409,10	ECBT1H561KB5	50V 560P	2	
C411,12	ECBT1H121KB5	50V 120P	2	
C413,14	ECBT1E103ZF	25V 0.01U	2	
C415,16	ECQV1H683JZ3	50V 0.068U	2	
C417,18	ECBT1H150JC5	50V 15P	2	
C419,20	ECBT1H561KB5	50V 560P	2	
C421,22	RCE1CKA100BG	16V 10U	2	
C501	ECEA1CKN4R7	16V 4.7U	1	
C502	ECEA0JKS101	6.3V 100U	1	
C503,04	RCE1HKASR3BG	50V 3.3U	2	
C505	ECBT1C272KR5	16V 2700P	1	(E EB EG EP)
C505	ECBT1C122KR5	16V 1200P	1	(PP)
C506	ECBT1C272KR5	16V 2700P	1	(E EB EG EP)
C506	ECBT1C122KR5	16V 1200P	1	(PP)
C507	ECBT1H102KB5	50V 1000P	1	(E EB EG EP)
C507	ECBT1C562KR5	16V 5600P	1	(PP)
C508	ECBT1H102KB5	50V 1000P	1	(E EB EG EP)
C508	ECBT1C562KR5	16V 5600P	1	(PP)
C509	ECEA1HKA330B	50V 33U	1	(E EB EG EP)
C509	ECA1JM330	63V 33U	1	(PP)
C510	ECEA1HSN2R2	50V 2.2U	1	
C511	ECBT1H330J5	50V 33P	1	(E EB EG EP)
C511	ECBT1H150J5	50V 15P	1	(PP)
C512	ECBT1H330J5	50V 33P	1	(E EB EG EP)
C512	ECBT1H150J5	50V 15P	1	(PP)
C513,14	RCE1CKA100BG	16V 10U	2	
C515,16	RCE1HKA3R3BG	50V 3.3U	2	
C517,18	ECBT1H104ZF5	50V 0.1U	2	
C519	ECEA0JKS101	6.3V 100U	1	
C520	ECBT1E223ZF	25V 0.022U	1	
C521,22	ECBT1C122KR5	16V 1200P	2	
C523	ECBT1H473ZF5	50V 0.047U	1	(E EB EG EP)
C523	ECBT1E223ZF	25V 0.022U	1	(PP)
C524	ECBT1H473ZF5	50V 0.047U	1	(E EB EG EP)
C524	ECBT1E223ZF	25V 0.022U	1	(PP)
C525,26	ECBT1H102KB5	50V 1000P	2	
C527,28	ECBT1H300J5	50V 30P	2	
C529,30	RCE1CKA100BG	16V 10U	2	
C531,32	ECBT1H104ZF5	50V 0.1U	2	
C533,34	ECBT1H102KB5	50V 1000P	2	
C535	ECBT1H473ZF5	50V 0.047U	1	(E EB EG EP)
C535	ECBT1E223ZF	25V 0.022U	1	(PP)
C536	ECBT1H473ZF5	50V 0.047U	1	(E EB EG EP)
C536	ECBT1E223ZF	25V 0.022U	1	(PP)
C537,38	ECA1EM101	25V 100U	2	
C539,40	ECBT1C562KR5	16V 5600P	2	
C541,42	ECBT1H331KB5	50V 330P	2	
C543,44	ECBT1C222KR5	16V 2200P	2	
C545	ECBT1E223ZF	25V 0.022U	1	
C546	ECEA1HKS010	50V 1U	1	
C547-50	ECBT1H104ZF5	50V 0.1U	4	
C551,52	RCE1CKA100BG	16V 10U	2	
C553,54	ECBT1H473ZF5	50V 0.047U	2	(E EB EG EP)
C555,56	ECBT1C472KR5	16V 4700P	2	(E EB EG EP)
C563,64	ECBT1H473ZF5	50V 0.047U	2	(E EB EG EP)
C701,02 △	ECA1EM472	25V 4700U	2	
C703	ECQE1104KF3	100V 0.1U	1	
C704	ECKR2H102ZF5	500V 1000P	1	

Ref. No.	Part No.	Part Name & Description	Pcs	Remarks
C705 △	ECA1HM470	50V 47U	1	
CN101	RJS2A5520-1	CONNECTOR (20P)	1	
CN102	RJS8T6ZA	CONNECTOR (8P)	1	
CN103	RJS10T6ZA	CONNECTOR (10P)	1	
CN104	RJU057W007	CONNECTOR (7P)	1	
CN105	RJU057W004	CONNECTOR (4P)	1	
CN106	RJU057W007	CONNECTOR (7P)	1	
CN701-10	RJS1A1101T1	CONNECTOR (1P)	10	
CN714,15	RJU057W007	CONNECTOR (7P)	2	
CN716	RJS4T6ZA	CONNECTOR (4P)	1	
CP104	RJT057W007-1	CONNECTOR (7P)	1	
CP105	RJT057W004-1	CONNECTOR (4P)	1	
CP106	RJT057W007-1	CONNECTOR (7P)	1	
CP701	RJS1A6604	CONNECTOR (4P)	1	
CP714,15	RJT057W007-1	CONNECTOR (7P)	2	
D101	MA4051M	DIODE	1	
D102-04	MA165	DIODE	3	
D105-10 △	RL1N4003N02	DIODE	6	
D111 △	MA4062M	DIODE	1	
D112 △	MA4240H	DIODE	1	
D113,14 △	1N5402BF	DIODE	2	
D115,16 △	RL1N4003N02	DIODE	2	
D117 △	MA4160M	DIODE	1	
D118 △	MA4110M	DIODE	1	
D119	RL1N4003N02	DIODE	1	
D120 △	RL1N4003N02	DIODE	1	
D121,22	MA165	DIODE	2	
D123	RL1N4003N02	DIODE	1	
D124 △	RL1N4003N02	DIODE	1	
D125,26	MA165	DIODE	2	
D127 △	RL1N4003N02	DIODE	1	
D128	MA165	DIODE	1	
D301,02 △	MA4075M	DIODE	2	
D303	MA4082M	DIODE	1	
D306	SLR-325VC	LED	1	
D307	MA165	DIODE	1	
D308	LMW9A8BYB0A1	LED	1	
D309,10 △	MA4120M	DIODE	2	
D311	MA4082M	DIODE	1	
D312,13 △	MA4075M	DIODE	2	
D501	MA4150M	DIODE	1	
D502	MA719TA	DIODE	1	
D701-04 △	1N5402BF	DIODE	4	
D705,06 △	RL1N4003N02	DIODE	2	
D707 △	MA4051M	DIODE	1	
D708-10	MA165	DIODE	3	
D711-14 △	RL1N4003N02	DIODE	4	
D715	MA165	DIODE	1	
F1 △	XBA2C06TB0	FUSE T0.63A	1	(E EB EG EP)

Ref. No.	Part No.	Part Name & Description	Pcs	Remarks
F1 △	XBA1C16NBAU	FUSE 12.5V 1.6A	1	(PP)
F2 △	XBA2C20TB0	FUSE T2A	1	(E EB EG EP)
FP701,02 △	RSFMB40KT-L	FUSE PROTECTOR	2	
IC301	M5218AFPE3	IC	1	
IC401	M5218AFPE3	IC	1	
IC501 △	RSN35H1-P	IC	1	
IC502	LM1B76TF	IC	1	
JK301	RJJ37TN01-2C	JACK HEADPHONES	1	
JK501	RJR0054E	JACK SPEAKER	1	
JK602	RJR0054H	JACK SPEAKER	1	
JK701 △	SJS9236	JACK AC INLET	1	(E EB EG EP)
JK701 △	SJSD16-1	JACK AC INLET	1	(PP)
L501-04	SLQY07G-40	COIL CHOKE	4	
L701 △	RLQZ371	COIL CHOKE	1	
P1	RPG4373	PACKING CASE (SYSTEM)	1	(E)
P1	RPG4375	PACKING CASE (SYSTEM)	1	(EB)
P1	RPG4374	PACKING CASE (SYSTEM)	1	(EG)
P1	RPG4376	PACKING CASE (SYSTEM)	1	(EP)
P1	RPG4377	PACKING CASE (SYSTEM)	1	(PP)
P2	RPG3672	PACKING CASE (AMPLIFIER)	1	
P2	RPG3673	PACKING CASE (DECK)	1	
P2	RPG3674	PACKING CASE (TUNER/CD)	1	
P3	RPN1094-1	CUSHION (AMPLIFIER)	1	
P3	RPN1095-3	CUSHION (DECK)	1	
P3	RPN1096-3	CUSHION (TUNER/CD)	1	
P4	SPP740-1	PROTECTION BAG	1	
P5	RPF0139	PROTECTION BAG (F.B.)	1	
P6	RPQ0164	PAD	1	
P7	RPQ0837	PAD	1	
P8	ROX9467ZA	WARRANTY ENVELOPE	1	(PP)
PCB1	REP2778B-M	OPERATION PCB	1	(E EB EG EP) (RTL)
PCB1	REP2778C-M	OPERATION PCB	1	(PP) (RTL)
PCB2	REP2779A-S	MAIN PCB	1	(RTL)
PT701 △	RTP2M5E014	POWER TRANSFORMER (MAIN)	1	(E EG EP)
PT701 △	RTP2M5B016	POWER TRANSFORMER (MAIN)	1	(EB)
PT701 △	RTP2M5C006	POWER TRANSFORMER (MAIN)	1	(PP)
PT702 △	RTP1I3E001	POWER TRANSFORMER (SUB)	1	(E EB EG EP)
PT702 △	RTP1H3C001	POWER TRANSFORMER (SUB)	1	(PP)
Q101 △	2SD2374PQAU	TRANSISTOR	1	
Q102 △	2SB621A-R	TRANSISTOR	1	
Q103	2SC3311ATA	TRANSISTOR	1	
Q104 △	2SC3940AQSTA	TRANSISTOR	1	

Ref. No.	Part No.	Part Name & Description	Pcs	Remarks
Q105 △	2SD2374PQAU	TRANSISTOR	1	
Q106	2SC3327A	TRANSISTOR	1	
Q301,02	2SC3327A	TRANSISTOR	2	
Q303	UN4115	TRANSISTOR	1	
Q304	2SA1309ATA	TRANSISTOR	1	
Q305	2SD592AR	TRANSISTOR	1	
Q306	2SB621A-R	TRANSISTOR	1	
Q307,08	2SC3327A	TRANSISTOR	2	
Q501	UN4115	TRANSISTOR	1	
Q502	2SC3311ATA	TRANSISTOR	1	
Q503,04	2SC3327A	TRANSISTOR	2	
Q505	2SC3311ATA	TRANSISTOR	1	
Q508,09	2SC3311ATA	TRANSISTOR	2	
Q510	2SA1309ATA	TRANSISTOR	1	
Q511	2SC3311ATA	TRANSISTOR	1	
Q512	2SA1309ATA	TRANSISTOR	1	
Q701,02	2SC3311ATA	TRANSISTOR	2	
R101	ERDS2FJ103	1/4W 10K	1	
R102	ERDS2FJ331	1/4W 330	1	
R104	ERDS2FJ101	1/4W 100	1	
R105,06 △	ERDS2FJ100	1/4W 10	2	
R107	ERDS2FJ222	1/4W 2.2K	1	
R108	ERDS2FJ472	1/4W 4.7K	1	
R109	ERDS2FJ473	1/4W 47K	1	
R110	ERDS2FJ392	1/4W 3.9K	1	
R111 △	ERDS1FJ181	1/2W 180	1	
R113	ERDS2FJ392	1/4W 3.9K	1	
R114	ERDS2FJ102	1/4W 1K	1	
R115	ERDS2FJ472	1/4W 4.7K	1	
R116 △	ERDS1FJ560	1/2W 56	1	
R117 △	ERD2FCG100	1/4W 10	1	
R118-20	ERDS2FJ102	1/4W 1K	3	
R301	ERDS2FJ821	1/4W 820	1	
R302	ERDS2FJ102	1/4W 1K	1	
R303	ERDS2FJ122	1/4W 1.2K	1	
R304	ERDS2FJ152	1/4W 1.5K	1	
R308	ERDS2FJ102	1/4W 1K	1	
R309,10 △	ERD25FVJ560T	1/4W 56	2	
R312	ERDS2FJ272	1/4W 2.7K	1	
R313,14	ERDS2FJ121	1/4W 120	2	
R315-18	ERDS2FJ470	1/4W 47	4	
R319,20	ERDS2FJ563	1/4W 56K	2	
R321,22	ERDS2FJ472	1/4W 4.7K	2	
R323,24 △	ERDS2FJ123	1/4W 12K	2	
R326 △	ERDS1FJ681	1/2W 680	1	
R327	ERDS2FJ103	1/4W 10K	1	
R328 △	ERDS1FJ471	1/2W 470	1	
R329,30	ERDS2FJ123	1/4W 12K	2	
R331,32	ERDS2FJ472	1/4W 4.7K	2	
R333,34	ERDS2FJ121	1/4W 120	2	
R335	ERDS2FJ103	1/4W 10K	1	
R336	ERDS2FJ121	1/4W 120	1	
R337-40	ERDS2FJ470	1/4W 47	4	
R401,02	ERDS2FJ104	1/4W 100K	2	
R403,04	ERDS2FJ223	1/4W 22K	2	
R405,06	ERDS2FJ182	1/4W 1.8K	2	
R407,08	ERDS2FJ473	1/4W 47K	2	
R411,12	ERDS2FJ223	1/4W 22K	2	
R413-16	ERDS2FJ104	1/4W 100K	4	
R417,18	ERDS2FJ333	1/4W 33K	2	
R419,20	ERDS2FJ152	1/4W 1.5K	2	
R423,24	ERDS2FJ331	1/4W 330	2	
R501,02	ERDS2FJ223	1/4W 22K	2	
R504	ERDS2FJ105	1/4W 1M	1	
R505-08	ERDS2FJ103	1/4W 10K	4	

Ref. No.	Part No.	Part Name & Description	Pcs	Remarks
R509,10	ERDS2FJ104	1/4W 100K	2	
R511,12	ERDS2FJ103	1/4W 10K	2	
R513,14	ERDS2FJ563	1/4W 56K	2	
R515	ERDS2FJ334	1/4W 330K	1	
R516 △	ERDS1FJ331	1/2W 330	1	
R517,18 △	ERDS2FJ2R2	1/4W 2.2	2	
R519,20	ERDS2FJ563	1/4W 56K	2	
R521	ERDS2FJ684	1/4W 680K	1	
R522	ERDS2FJ473	1/4W 47K	1	
R523,24	ERDS2FJ272	1/4W 2.7K	2	
R525,26 △	ERDS2FJ100	1/4W 10	2	
R527,28 △	ERDS1FJ100	1/2W 10	2	
R529	ERDS2FJ823	1/4W 82K	1	
R530	ERDS2FJ124	1/4W 120K	1	
R531	ERDS2FJ563	1/4W 56K	1	
R532	ERDS2FJ564	1/4W 560K	1	
R533	ERDS2FJ223	1/4W 22K	1	
R534	ERDS2FJ103	1/4W 10K	1	
R535,36	ERDS2FJ473	1/4W 47K	2	
R537	ERDS2FJ152	1/4W 1.5K	1	(E EB EG EP)
R537	ERDS2FJ122	1/4W 1.2K	1	(PP)
R538	ERDS2FJ152	1/4W 1.5K	1	(E EB EG EP)
R538	ERDS2FJ122	1/4W 1.2K	1	(PP)
R539,40	ERDS2FJ103	1/4W 10K	2	
R541,42	ERDS2FJ104	1/4W 100K	2	
R543,44 △	ERDS2FJ100	1/4W 10	2	
R545	ERDS2FJ124	1/4W 120K	1	
R546	ERDS2FJ823	1/4W 82K	1	
R547,48 △	ERDS1FJ100	1/2W 10	2	
R549	ERDS2FJ563	1/4W 56K	1	
R550	ERDS2FJ223	1/4W 22K	1	
R551,52	ERX1SJR33	1W 0.33	2	
R553	ERDS2FJ103	1/4W 10K	1	(E EB EG EP)
R553	ERDS2FJ102	1/4W 1K	1	(PP)
R554	ERDS2FJ103	1/4W 10K	1	(E EB EG EP)
R554	ERDS2FJ102	1/4W 1K	1	(PP)
R555	ERDS2FJ103	1/4W 10K	1	(E EB EG EP)
R555	ERDS2FJ223	1/4W 22K	1	(PP)
R556	ERDS2FJ103	1/4W 10K	1	(E EB EG EP)
R556	ERDS2FJ223	1/4W 22K	1	(PP)
R557	ERDS2FJ564	1/4W 560K	1	
R559,60 △	ERDS1FJ471	1/2W 470	2	
R561	ERDS2FJ1R0	1/4W 1	1	(PP)
R701	ERDS2FJ102	1/4W 1K	1	
R702	ERDS2FJ392	1/4W 3.9K	1	
R703	ERDS2FJ333	1/4W 33K	1	
R704 △	ERDS1FJ181	1/2W 180	1	
R705	ERDS2FJ102	1/4W 1K	1	
R706	ERDS2FJ392	1/4W 3.9K	1	
R707	ERDS2FJ684	1/4W 680K	1	
R708	ERDS2FJ104	1/4W 100K	1	
R709	ERDS2FJ473	1/4W 47K	1	
R711 △	ERC12UGK335D	1/2W 3.3M	1	(PP)
RL101 △	RSY0017M-0	RELAY	1	(E EB EG EP)
RL101 △	RSY0023M-0	RELAY	1	(PP)
RL701 △	RSY0017M-0	RELAY	1	(E EB EG EP)
RL701 △	RSY0023M-0	RELAY	1	(PP)
RL702 △	RSY0040M-0	RELAY	1	
S301-03	EVQ21405R	SW TACT	3	

Ref. No.	Part No.	Part Name & Description	Pcs	Remarks
S308,09	EVQ21405R	SW TACT	2	
VR301	EVQVBXFK124B	V.R. VOLUME	1	
VR401	EVJY91F04B54	V.R. FINE TWEETER CONT.	1	
Z701 △	ERZV10V511CS	COMPONENT COMBINATION	1	

15 Cabinet Parts Location

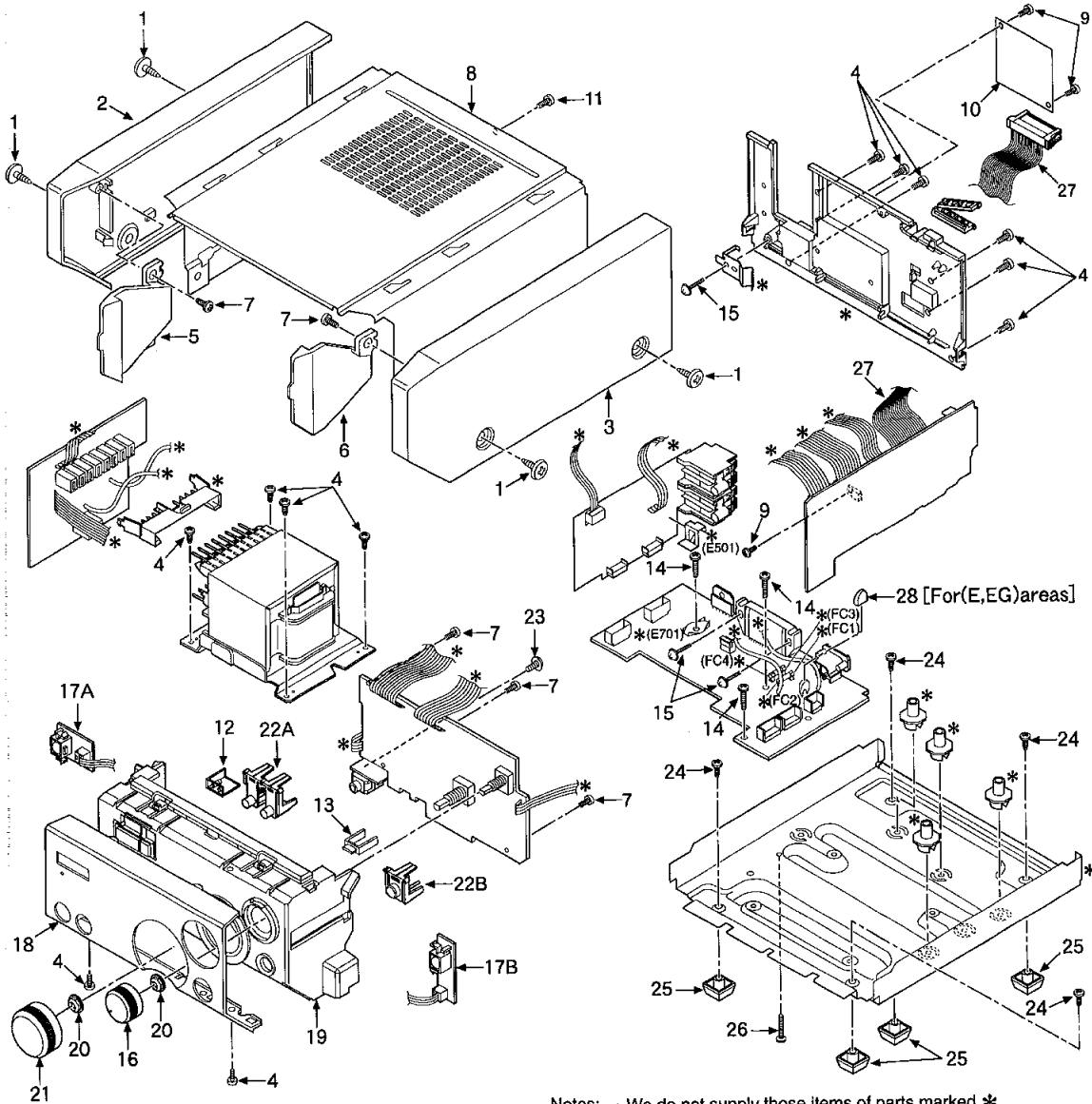

Ref.No.22 button cutting illustration.

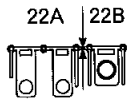

Cut off the button at ← point.

- Notes:
- We do not supply those items of parts marked *.
 - *(FC3),*(FC4): For areas except (PP).
 - About the part of Ref.No.17A and B, please use after cutting off the part of Ref. No.17 at "Replacement Parts List".
(Ref.No.17A : D305 is on the printed circuit board.
Ref.No.17B : D304 is on the printed circuit board.)
 - About the parts of Ref.No.22A and B, please use after cutting off the part of Ref.No.22 at "Replacement Parts List".

Ref. No.	Part No.	Part Name & Description	Pcs	Remarks
1	RHD30007-S	SCREW	4	
2	RGK0972-1S	SIDE PANEL (L)	1	
3	RGK0973-1S	SIDE PANEL (R)	1	
4	XTBS3+8JFZ1	SCREW	12	
5	RGL0394-Q	PANEL LIGHT (L)	1	
6	RGL0395-Q	PANEL LIGHT (R)	1	
7	XTBS26+8J	SCREW	5	
8	RKM0364B-1S	CABINET	1	
9	XTB3+8JFZ	SCREW	3	
10	RGH0153B-K	NAME PLATE	1	(E, EG)
10	RGH0153C-K	NAME PLATE	1	(EB)
10	RGH0153D-K1	NAME PLATE	1	(EP)
10	RGH0153E-K1	NAME PLATE	1	(PP)
11	XTBS3+10JFZ1	SCREW	1	
12	RGL0393-Q	PANEL LIGHT	1	
13	RGL0431-Q	MD INDICATOR	1	

Ref. No.	Part No.	Part Name & Description	Pcs	Remarks
14	XTB3+20JFZ	SCREW	3	
15	XTW3+15T	SCREW	3	
16	RGW0303-S	KNOB CONTROL	1	
17	REP2684A-S	LED L R P.C.B.	1	
18	RGG0161B-S	FRONT PANEL	1	(E EB EG EP)
18	RGG0161C-S	FRONT PANEL	1	(PP)
19	RGPO699A-S	SUB PANEL	1	
20	RHN90001	NUT	2	
21	RGW0277-1S	KNOB VOLUME	1	
22	RGU1716-S	BUTTON INPUT	1	
23	RHD26016	SCREW	1	
24	XTB3+5JFZ	SCREW	4	
25	RKA0098-K	FOOT	4	
26	XTB3+12FFZ	SCREW	1	
27	REX0962	FLAT CABLE (20P)	1	
28	RMZ0339	ZNR COVER	1	(E EB EG EP)

16 Packaging

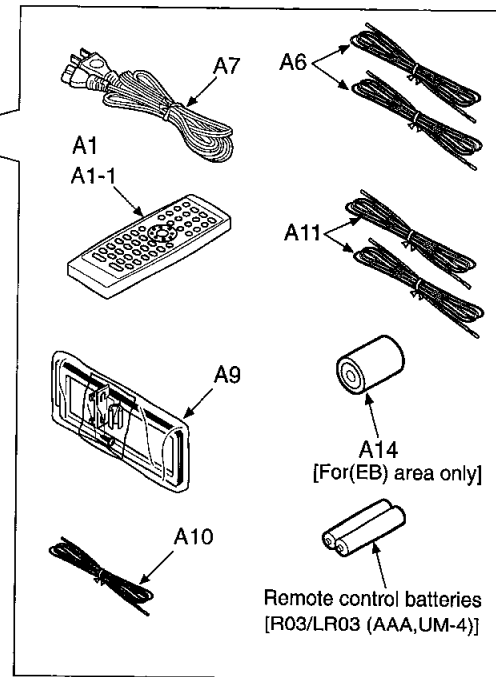
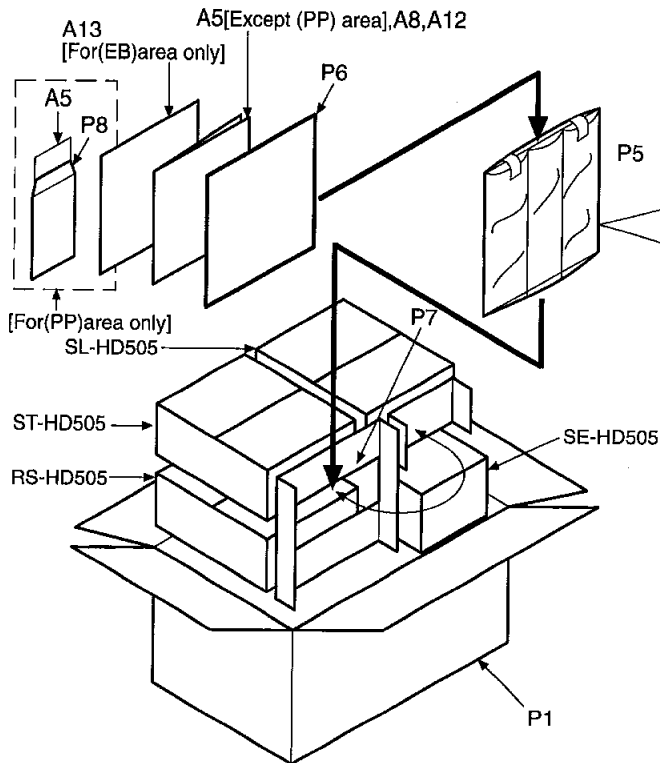
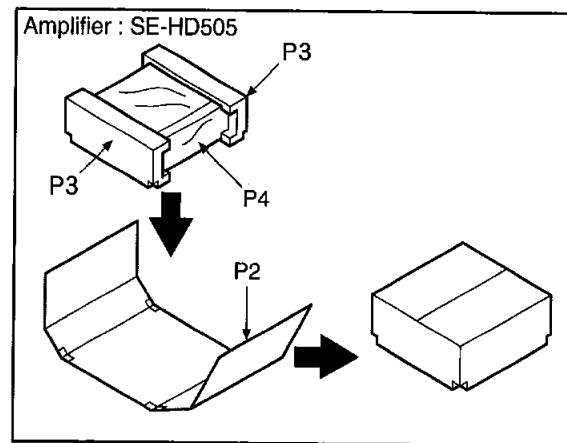
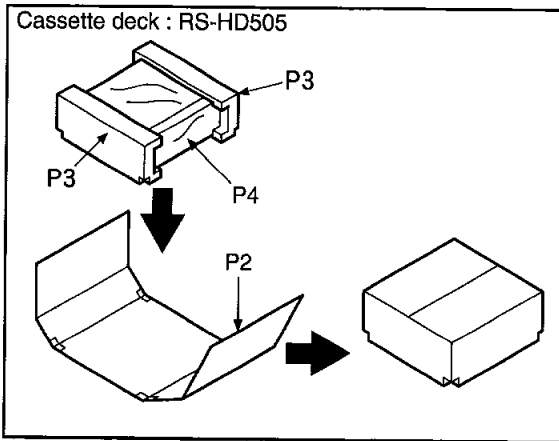
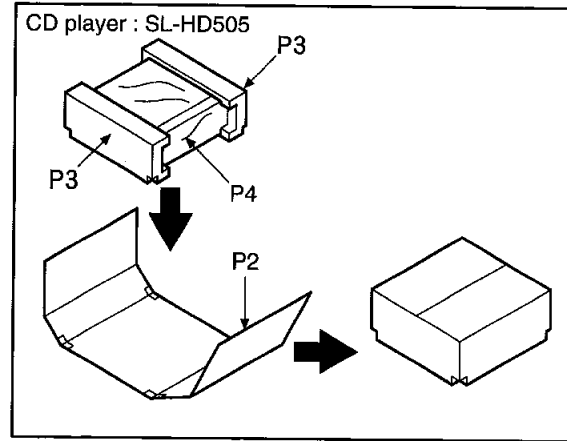
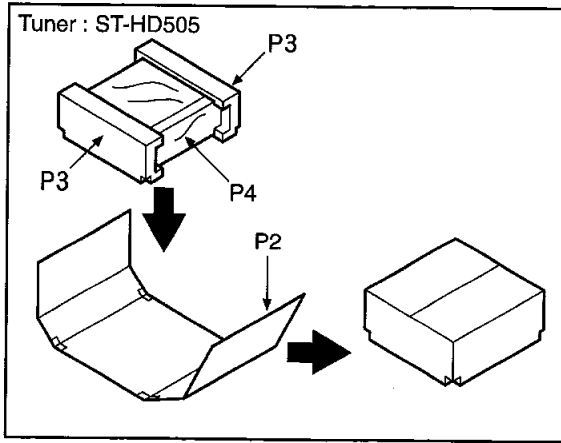

Ref. No.	Part No.	Part Name & Description	Pcs	Remarks
A1	RAK-HDA10WH	REMOTE CONT. TRANSMITTER	1	
A1-1	RKR0123-H	BATT. COVER (REMOTE CONT.)	1	
A5	RQA0117	WARRANTY CARD	1	(E EB EG EP)
A5	RQA0149	WARRANTY CARD (FOR U.S.A)	1	(PP)
A5	SQX7183	WARRANTY CARD (FOR CANADA)	1	(PP)
A6	REE0499	SPEAKER CORD	2	
A7 △	RJA0019-X	AC POWER SUPPLY CORD	1	(E EG EP)
A7 △	RJA0053-2X	AC POWER SUPPLY CORD	1	(EB)
A7 △	RJA0065-K	AC POWER SUPPLY CORD	1	(PP)
A8	RQT4929-E	INSTRUCTION MANUAL	1	(E) <IA>
A8	RQT4930-D	INSTRUCTION MANUAL	1	(EG) <IB>
A8	RQT4931-H	INSTRUCTION MANUAL	1	(EG) <IC>
A8	RQT4932-B	INSTRUCTION MANUAL	1	(EB EP) <ID>
A8	RQT4933-R	INSTRUCTION MANUAL	1	(EP) <IE>
A8	RQT4934-P	INSTRUCTION MANUAL	1	(PP) <IF>
A8	RQT4935-C	INSTRUCTION MANUAL	1	(PP) <IG>
A9	RSA0021	AM LOOP ANTENNA	1	
A10	RSA0007	FM INDOOR ANTENNA	1	(E EB EG EP)
A10	RSA0006	FM INDOOR ANTENNA	1	(PP)
A11	REE0853	SPEAKER CORD	2	
A12	RQCB0169	SERVICENTER LIST	1	(E EB EG EP)
A12	RQCB0391	SERVI. LIST (FOR U.S.A.)	1	(PP)
A12	RQCB0832	SERVI. LIST (FOR CANADA)	1	(PP)
A13	RQCA0666	QUICK SET UP GUIDE	1	(EB)
A14	SJP9009	AC PLUG ADAPTOR	1	(EB)
P1	RPG4373	PACKING CASE (SYSTEM)	1	(E)
P1	RPG4375	PACKING CASE (SYSTEM)	1	(EB)
P1	RPG4374	PACKING CASE (SYSTEM)	1	(EG)
P1	RPG4376	PACKING CASE (SYSTEM)	1	(EP)
P1	RPG4377	PACKING CASE (SYSTEM)	1	(PP)
P2	RPG3672	PACKING CASE (AMPLIFIER)	1	
P2	RPG3673	PACKING CASE (DECK)	1	
P2	RPG3674	PACKING CASE (TUNER/CD)	1	
P3	RPN1094-1	CUSHION (AMPLIFIER)	1	
P3	RPN1095-3	CUSHION (DECK)	1	
P3	RPN1096-3	CUSHION (TUNER/CD)	1	
P4	SPP740-1	PROTECTION BAG	1	
P5	RPF0139	PROTECTION BAG (F.B.)	1	
P6	RPQ0164	PAD	1	
P7	RPQ0837	PAD	1	
P8	RQX9467ZA	WARRANTY ENVELOPE	1	(PP)

