

# Service Manual

Amplifier

Amplifier

SE-HD81

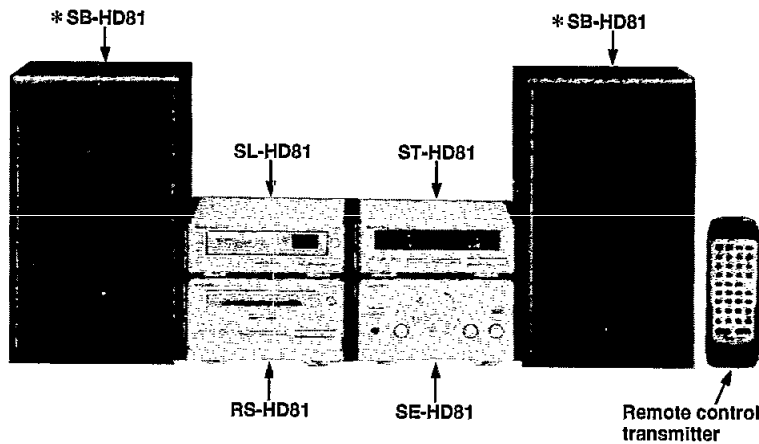

## Colour

(N) ..... Gold

## Areas

E ..... Europe.

EG ..... Germany and Italy, etc.

EB ..... Great Britain.

EP ..... Europe and Russia.

System : SC-HD81

Because of unique interconnecting cables, when a compact requires service, send or bring in the entire system.

## Specifications

### Amplifier Section

#### Power output

DIN 1 kHz, THD 1 %, both channel driven:  $2 \times 45$  W (6 ohm)RMS 1 kHz, THD 10 %, both channel driven:  $2 \times 60$  W (6 ohm)

#### Total harmonic distortion

Rated power at 1 kHz: 1 % (6 ohm)

Half power at 1 kHz: 0.09 % (6 ohm)

#### Load impedanced: 6 ohm

S/N (rated power): 90 dB

### General

Power consumption: 100 W

#### Power supply

[ For (EB) area ]: 230 — 240 V, AC 50 Hz

[ For (E, EG, EP) areas ]: 230 V, AC 50 Hz

Dimensions: 196(W)/103(H)/255(D) mm

Weight: 4.1 kg

#### Notes:

1. Specifications are subject to change without notice.
2. Weight are dimensions are approximate.
3. Total harmonic distortion is measured by the digital spectrum analyzer.

### System/SC-HD81:

Tuner: ST-HD81, Compact Disc Player: SL-HD81, Amplifier: SE-HD81, Cassette Deck: RS-HD81, Speaker: \*SB-HD81

Notes:\*..... Made in PAES

### △WARNING

This service information is designed for experienced repair technicians only and is not designed for use by the general public. It does not contain warnings or cautions to advise non-technical individuals of potential dangers in attempting to service a product. Products powered by electricity should be serviced or repaired only by experienced professional technicians. Any attempt to service or repair the product or products dealt with in this service information by anyone else could result in serious injury or death.

© 1998 Matsushita Electric Industrial Co., Ltd.  
All rights reserved. Unauthorized copying and distribution is a violation of law.

# Technics®

## Contents

	Page		Page
Accessories .....	2	Wiring Connection Diagram .....	10
Before Repair and Adjustment .....	2	To Supply Power Source .....	11
Caution for AC Main Lead .....	3	Type Illustration of ICs, Transistors and Diodes .....	11
Protection Circuitry .....	4	Schematic Diagram .....	12 ~ 17
Location of Controls .....	4	Printed Circuit Board Diagram .....	18 ~ 20
Installation .....	4	Block Diagram .....	21, 22
Connections .....	5, 6	Replacement Parts List .....	23 ~ 25
Changing the Tone .....	7	Cabinet Parts Location .....	26
Convenient Functions .....	7	Packaging .....	27
Operation Checks and Main Component Replacement Procedures .....	8 ~ 10		

## Accessories

- AC power supply cord ..... 1 pc.  
For (EB) area: (RJA0053-1X)      For (E, EG, EP) area: (RJA0019-X)
- Remote control transmitter ..... 1 pc.  
(RAK-CH214WH)
- Speaker cords ..... 2 pcs.  
(RFA0737-R)



- Remote control batteries ..... 2 pcs.  
[[R03/LR03 (AAA, UM-4)]  
Note: These are available on sales route.
- AM loop antenna set (RSA0021)  
AM loop antenna ..... 1 pc.  
Antenna holder with stand ..... 1 pc.
- Antenna holder without stand ..... 1 pc.  
Screw ..... 1 pc.



- FM indoor antenna ..... 1 pc.  
(RSA0007)
- Flat cable (short) ..... 1 pc.  
(REX0608)
- Flat cable (Long thick) ..... 1 pc.  
(REX0812)



- Flat cable (Long thin) ..... 1 pc.  
(REX0813)
- Antenna plug adaptor ..... 1 pc.  
For (EB) area only:  
(SJP9009)



## Before Repair and Adjustment

- (1) Turn off the power supply using a 10 Ω, 10 W resistor, connect both ends of power supply capacitors (C715 ~ 718) in order to discharge the voltage.
- (2) Before turning the power supply on, after completion of repair, slowly apply the primary voltage by using a power supply voltage controller to make sure that the consumed current at 50/60 Hz in NO SIGNAL mode should be shown below with respect to supply voltage 230 V/240 V.

Area	(E) (EG) (EP)		(EB)	
Power supply voltage	AC 230V		AC 240 V	
Consumed current 50/60 Hz	50 Hz	60 ~ 180 mA	50 Hz	55 ~ 175 mA
	60 Hz	48 ~ 144 mA	60 Hz	44 ~ 140 mA

## Caution for AC Main Lead



[ For (EB) area only. ]

For your safety, please read the following text carefully.

This appliance is supplied with a moulded three pin mains plug for your safety and convenience.

A 5-ampere fuse is fitted in this plug.

Should the fuse need to be replaced please ensure that the replacement fuse has a rating of 5-ampere and that it is approved by ASTA or BSI to BS1362.

Check for the ASTA mark  or the BSI mark  on the body of the fuse.

If the plug contains a removable fuse cover you must ensure that it is refitted when the fuse is replaced.

If you lose the fuse cover the plug must not be used until a replacement cover is obtained.

A replacement fuse cover can be purchased from your local dealer.

### CAUTION!

IF THE FITTED MOULDED PLUG IS UNSUITABLE FOR THE SOCKET OUTLET IN YOUR HOME THEN THE FUSE SHOULD BE REMOVED AND THE PLUG CUT OFF AND DISPOSED OF SAFELY.

THERE IS A DANGER OF SEVERE ELECTRICAL SHOCK IF THE CUT OFF PLUG IS INSERTED INTO ANY 13-AMPERE SOCKET.

If a new plug is to be fitted please observe the wiring code as shown below.

If in any doubt please consult a qualified electrician.

### IMPORTANT

The wires in this mains lead are coloured in accordance with the following code:

Blue: Neutral, Brown: Live.

As these colours may not correspond with the coloured markings identifying the terminals in your plug, proceed as follows:

The wire which is coloured Blue must be connected to the terminal which is marked with the letter N or coloured Black or Blue.

The wire which is coloured Brown must be connected to the terminal which is marked with the letter L or coloured Brown or Red.

**WARNING: DO NOT CONNECT EITHER WIRE TO THE EARTH TERMINAL WHICH IS MARKED WITH THE LETTER E, BY THE EARTH SYMBOL  OR COLOURED GREEN OR GREEN/YELLOW.**

**THIS PLUG IS NOT WATERPROOF—KEEP DRY.**

### Before use

Remove the connector cover.

### How to replace the fuse

The location of the fuse differ according to the type of AC mains plug (figures A and B). Confirm the AC mains plug fitted and follow the instructions below.

Illustrations may differ from actual AC mains plug.

1. Open the fuse cover with a screwdriver.

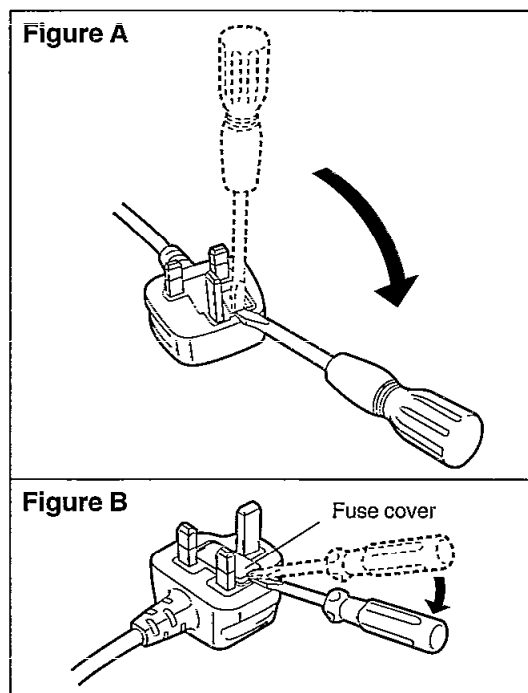

2. Replace the fuse and close or attach the fuse cover.

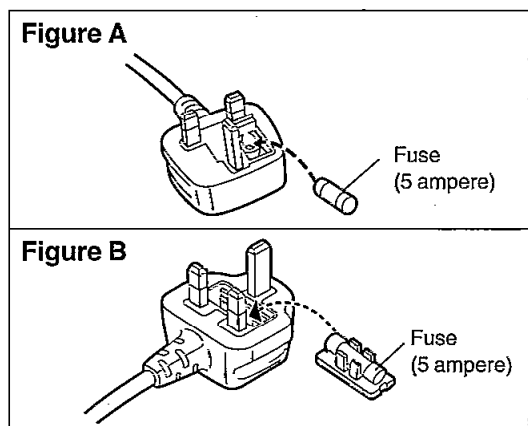

## Protection Circuitry

The protection circuitry may have operated if either of the following conditions is noticed:

- \*No sound is heard when the power is switched ON.
- \*Sound stops during a performance.

The functions of this circuitry is prevent circuitry damage if, for example, the positive and negative speaker connection wires are "shorted", or if speaker systems with an impedance less than the indicated rated impedance of this unit are used.

If this occurs, follow the procedure outlined below:

1. Switch OFF the power.
2. Determine the cause of the problem and correct it.
3. Switch ON the power once again.

### Note:

When the protection circuitry functions, the unit will not operate unless the power is first switched OFF and then ON again.

## Location of Controls

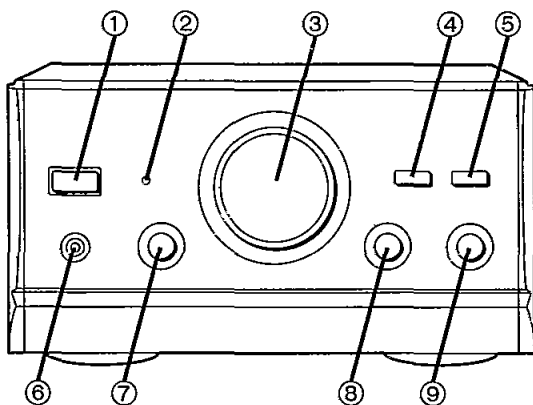

- ① Power "STANDBY  $\odot$ /ON" switch (POWER, STANDBY  $\odot$ /ON)  
Press to switch the unit from on to standby mode or vice versa. In standby mode, the unit is still consuming a small amount of power.
- ② Standby indicator (STANDBY)  
When the unit is connected to the AC mains supply, this indicator lights up in standby mode and goes out when the unit is turned on.
- ③ Volume control (VOLUME)
- ④ Source direct button (SOURCE DIRECT)
- ⑤ Vocal presence button (VOCAL PRESENCE)
- ⑥ Headphones jack (PHONES)
- ⑦ Balance control (BALANCE)
- ⑧ Bass control (BASS)
- ⑨ Treble control (TREBLE)

## Installation

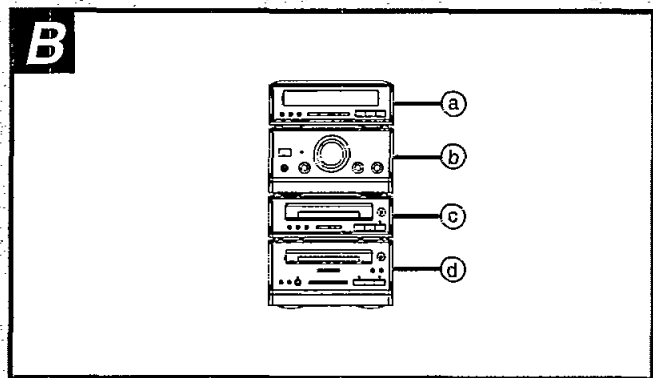
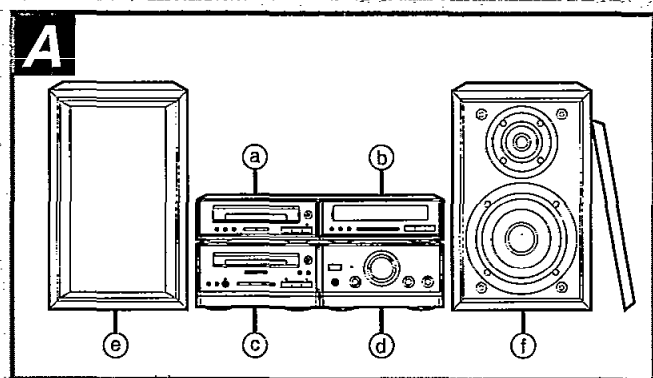

### Locating the components

#### Side-by-side set-up **A**

- a) CD changer
- b) Tuner
- c) Cassette deck
- d) Amplifier
- e) Left speaker
- f) Right speaker

#### Stacking **B**

- a) Tuner
- b) Amplifier
- c) CD changer
- d) Cassette deck

#### Caution

Use the speakers only with the recommended system. Failure to do so may lead to damage to the amplifier and/or the speaker, and may result in the risk of fire. Consult a qualified service person if damage has occurred or if you experience a sudden change in performance.

#### Note

Left and right speakers are exactly the same.

# Connections

Connect the AC mains lead after you have connected all other cables.

To prepare the AM loop antenna wire and speaker cords, twist the vinyl cover tip and pull off.

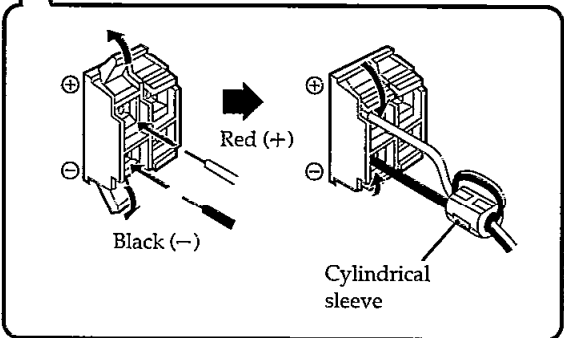
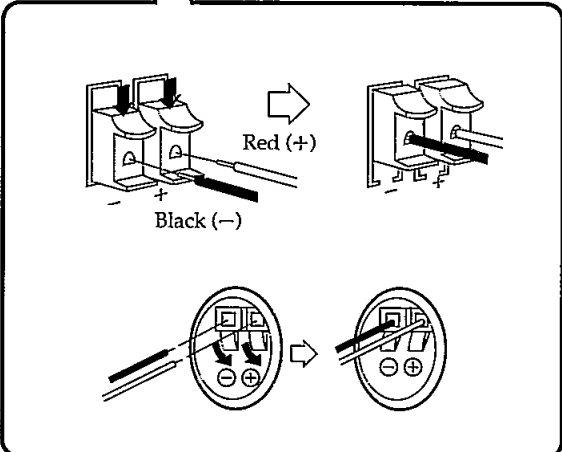
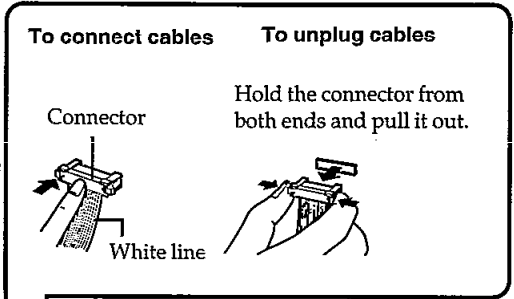
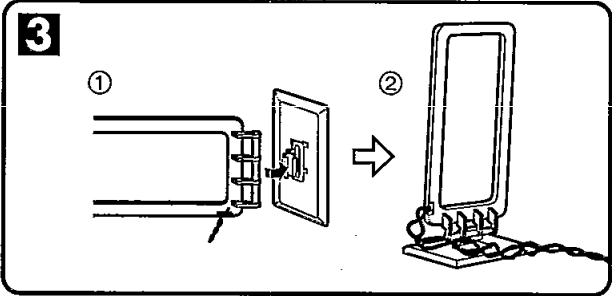
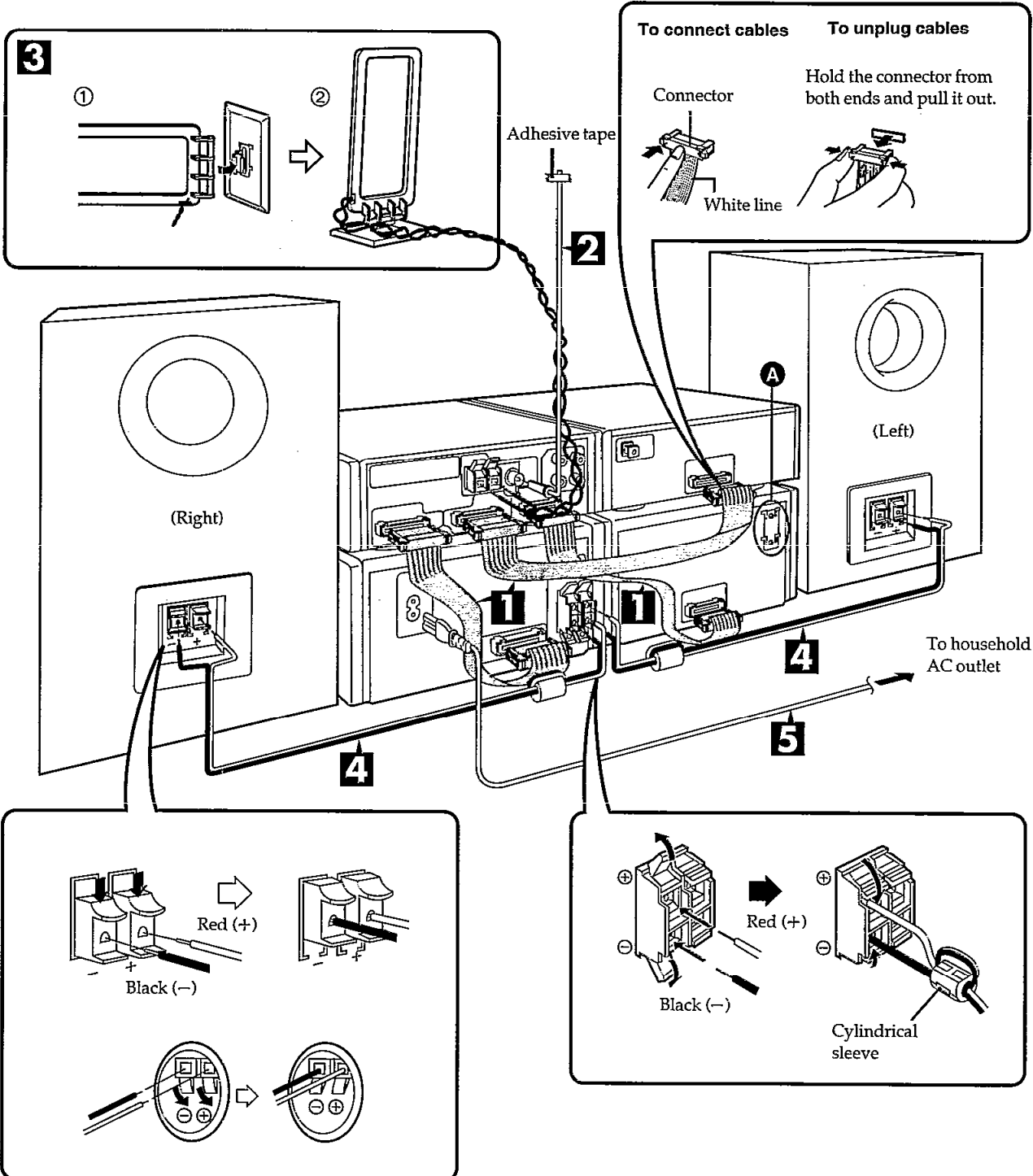
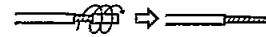

**1 Connect the flat cables.**

1. Connect the short flat cable to the terminal of the A1 and A2.
2. Connect the long thick flat cable to the terminal of the B1 and B2.
3. Connect the long thin flat cable to the terminal of the C1 and C2.

**Note**

Do not try connecting or disconnecting the flat cables while the power is switched to ON.

**After connection:**

Keep cables as flat against the back of the unit as possible.

**2 Connect the FM indoor antenna.**

Tape the antenna to a wall or column, in a position where radio signals are received with the least amount of interference.

**Note**

When you cannot get a good reception with this FM indoor antenna, we recommend you install an FM outdoor antenna (not included).

**3 Connect the AM loop antenna.**

You can also install the AM loop antenna on the rear of the cassette deck, wall or pillars.

In this case, be sure to use the antenna holder with the hole.

- To install on the cassette deck rear (A)

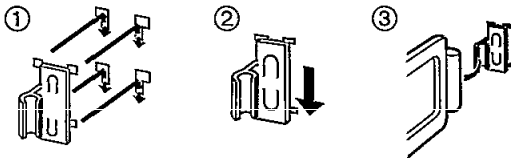

- To install on walls or pillars

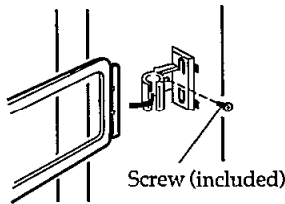

**Note**

To minimize noise pickup, bundle the loop antenna cord using a tape or so to keep the flat cables away from the AM loop antenna cord.

**4 Connect the right (R) and left (L) front speaker cables.**

**Note**

- For SC-HD81 connect the end of the speaker cable with the cylindrical sleeve to the amp side.
- To prevent damage to circuitry, never short-circuit positive (+) and negative (-) speaker wires.
- Be sure to connect only positive (red) wires to positive (+) terminals and negative (black) wires to negative (-) terminals.

These speakers are made so as to be able to be used in close proximity to the TV, but irregular coloring may result due to how the system is placed. If such distortion occurs, turn off the TV for sometime between 15 and 30 minutes. The demagnetizing function of the TV will eliminate the distortion. If the irregular coloring is still visible, then move the speaker further away from the TV. Please note that if there is a magnetic object near the TV, irregular coloring may result due to the interaction between the TV and the speakers.

**5 Connect the AC mains lead.**

**(United Kingdom only)**  
**BE SURE TO READ THE CAUTION FOR AC MAINS LEAD ON PAGE 4 BEFORE PROCEEDING TO STEP 5.**

**Insertion of Connector**

Even when the connector is perfectly inserted, depending on the type of inlet used, the front part of the connector may jut out as shown in the drawing.

However there is no problem using the unit.

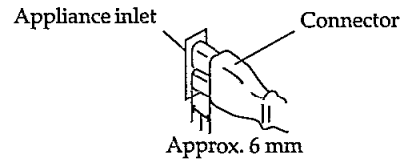

## Changing the Tone

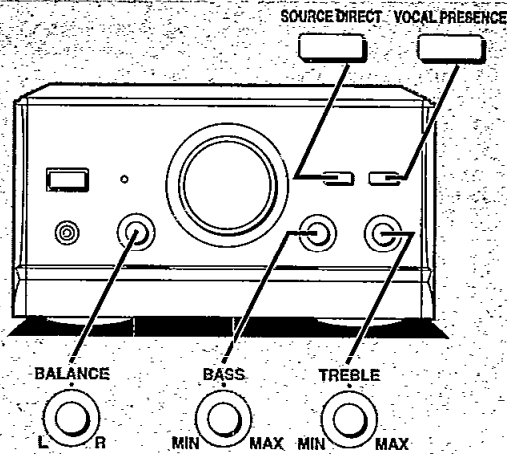

### A VOCAL PRESENCE



### B SOURCE DIRECT



### C BALANCE



### D BASS

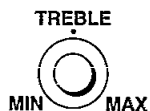

### E

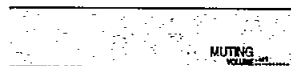
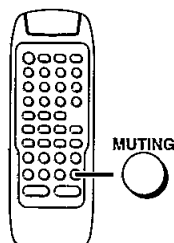

## Listening with Vocal Presence A

### Press VOCAL PRESENCE.

The button will light up. Vocal Presence accentuates midrange sounds to make voices stand out. (Vocal Presence cannot be used at the same time as SOURCE DIRECT.)

### To cancel

Press VOCAL PRESENCE again.

## For clearer sound B

### Press SOURCE DIRECT.

The button will light up. Voice signals will not be fed through the tone control circuit, so you get a clearer sound. (You cannot adjust BASS or TREBLE when using SOURCE DIRECT.)

### To cancel

Press SOURCE DIRECT again.

## To adjust the sound balance C

Turn BALANCE to adjust the left/right sound balance.

### Note

The effect works only with playback. It cannot be used in recording.

## To adjust the tone quality D

Turn BASS to adjust the low-frequency sound.

Turn TREBLE to adjust the high-frequency sound.

### Note

The effect works only with playback. It cannot be used in recording.

## Convenient Functions E

### To mute the volume

This feature is convenient when you have a telephone call, etc.

### by remote control only

### Press MUTING.

"MUTING" will light.

To cancel, press MUTING once again. ("MUTING" goes out.)

To cancel from the amplifier, reduce the volume level to the minimum position (— dB) and then reset to the desired volume. Muting is also canceled if you turn OFF the system.

## ■ Operation Checks and Main Component Replacement Procedures

### NOTE

1. This section describes procedures for checking the operation of the major printed circuit boards and replacing the main components.
2. For reassembly after operation checks or replacement, reverse the respective procedures. Special reassembly procedures are described only when required.
3. Select items from the following index when checks or replacement are required.
4. Refer the parts No. on the page of "Main Component Replacement Procedures", if necessary.

### ● Contents

#### •Checking Procedures for each P.C.B.

	Page.
1. Checking for the operation P.C.B..	8.
2. Checking for the PDM P.C.B..	9.

#### •Main Component Replacement Procedures

1. Replacement for the regulator transistor.	10.
--	-----

## ■ Checking Procedure for each P.C.B.

### 1. Checking for the operation P.C.B.

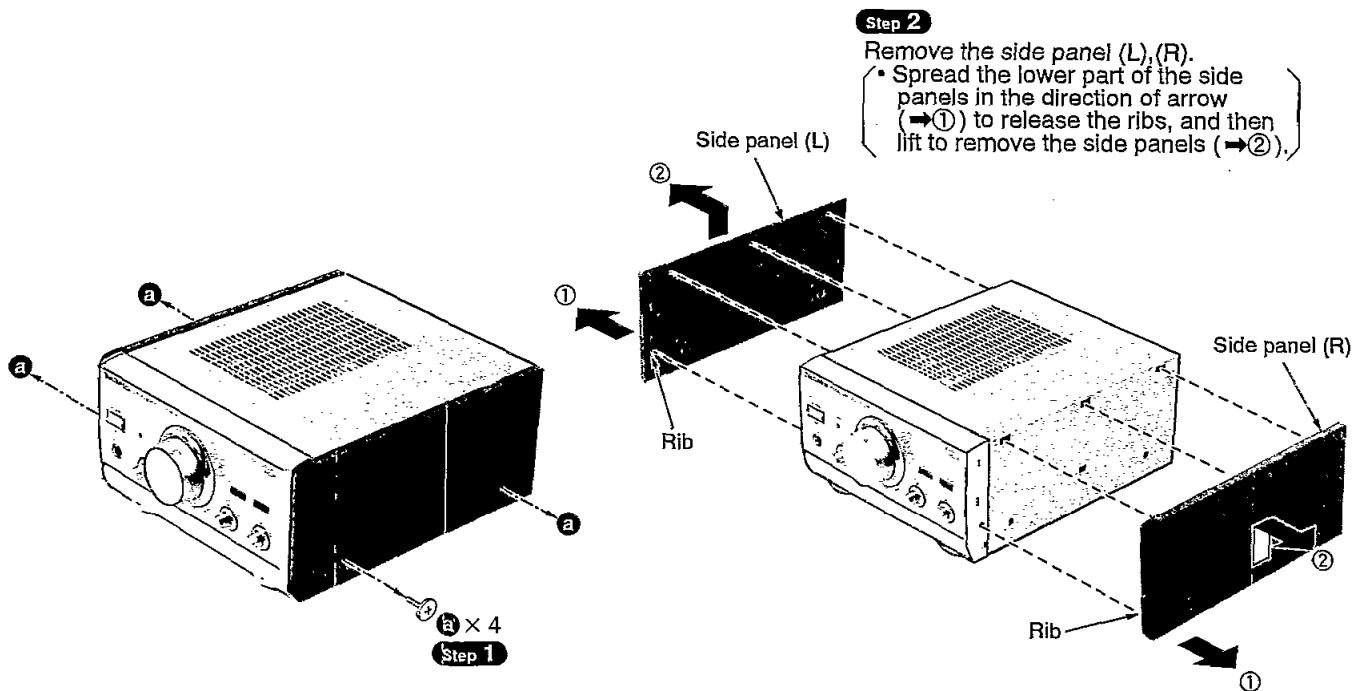



**Step 4**

Remove the cabinet.

**Step 3**

**b**

**Step 6**

Pull out the front panel ass'y.

**Step 5**

**c** × 2

**c**

• Check the operation P.C.B. as shown below.

Operation P.C.B. (Solder side)

**2. Checking for the PDM P.C.B.**

• Follow **Step 1** ~ **Step 6** in Item 1 on pages 8 and 9.

**Step 1**

**a** × 4

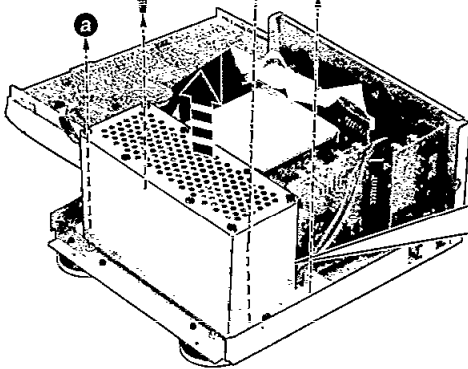

• Check the PDM P.C.B. as shown below.

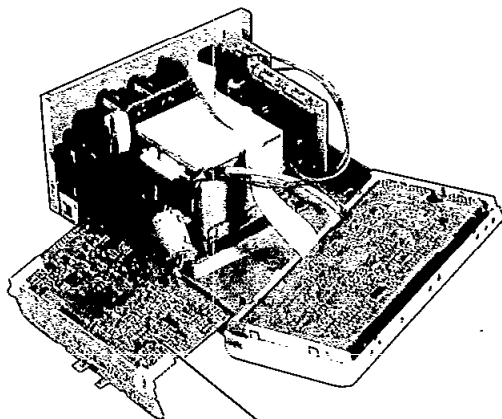

PDM P.C.B.

**Step 5**

**e** × 8

**Step 7**

Remove the PDM P.C.B..

**b** × 2

**Step 2**

**Step 4**

Unsolder and remove the PDM ground plate.

**d** × 2

**Step 6**

**c** × 8

**Step 3**

## Main Component Replacement Procedures

### 1. Replacement for the regulator transistor

- Follow **Step 1** ~ **Step 6** in item 1 on pages 8 and 9.
- Follow **Step 1** ~ **Step 7** in item 2 on page 9.

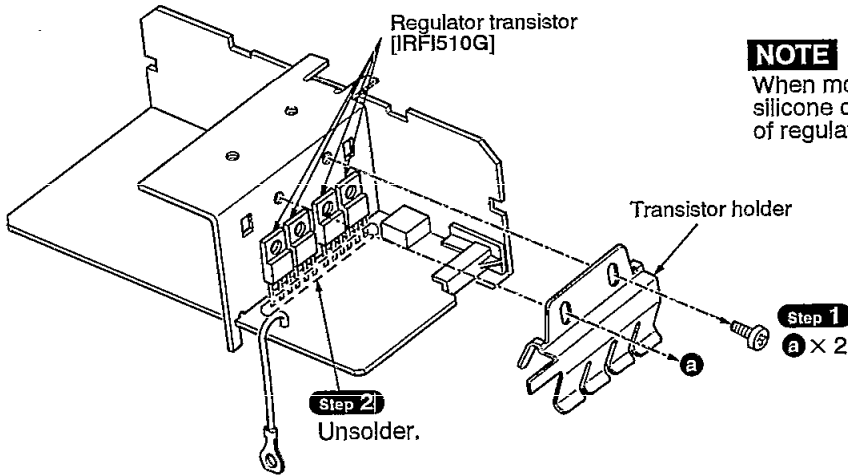

#### NOTE

When mounting the regulator transistor, apply silicone compound (RFKX0002) to the rear side of regulator transistor.

## Wiring Connection Diagram

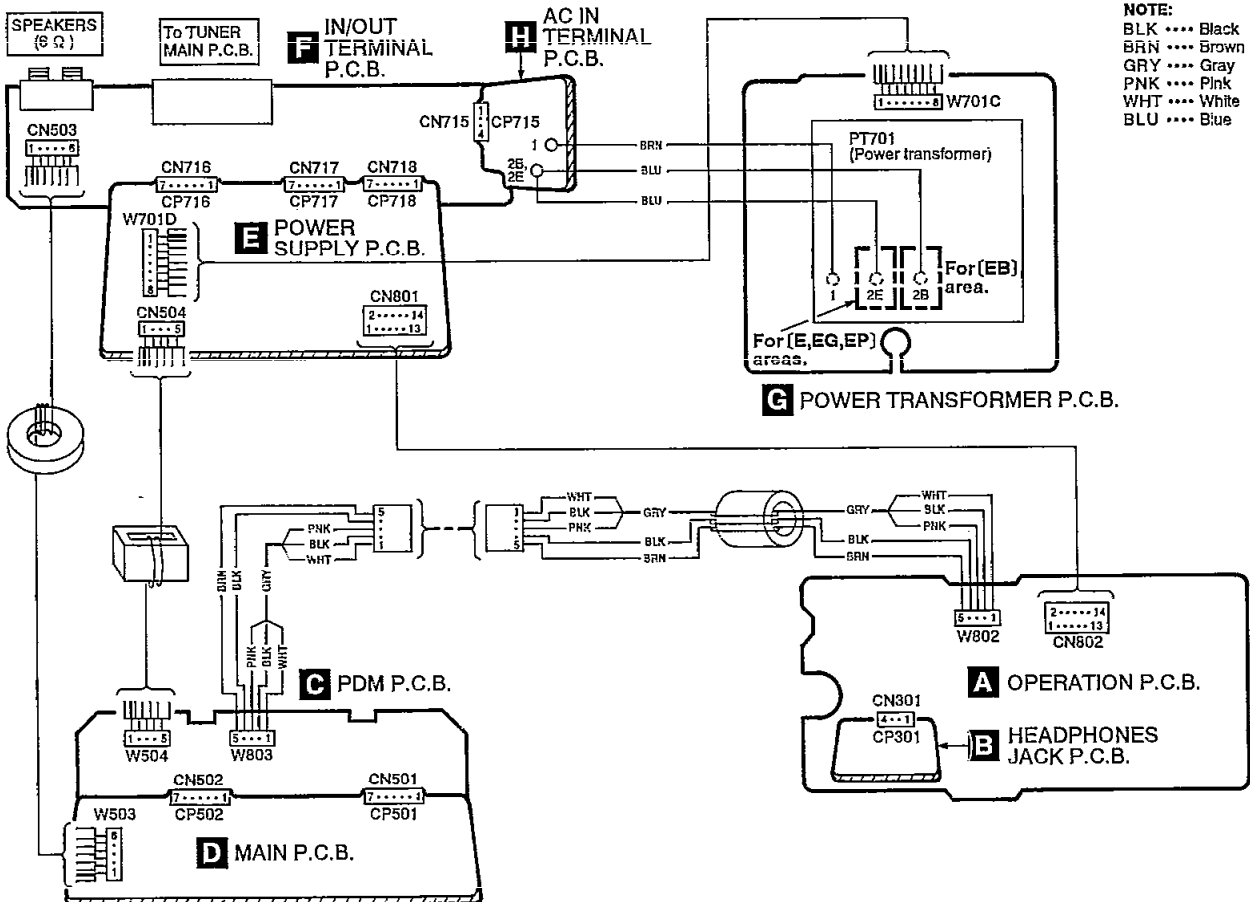

## ■ To Supply Power Source

This unit SE-HD81 is not operate normary without connecting the unit ST-HD81.

When operate the unit SE-HD81, be sure to connect the unit ST-HD81 with included connection cable.

1. Connect the tuner ST-HD81 to this unit SE-HD81.
2. Connect the AC power supply cord.
3. Connect the speakers to speaker input terminal.
4. Press the power switch.

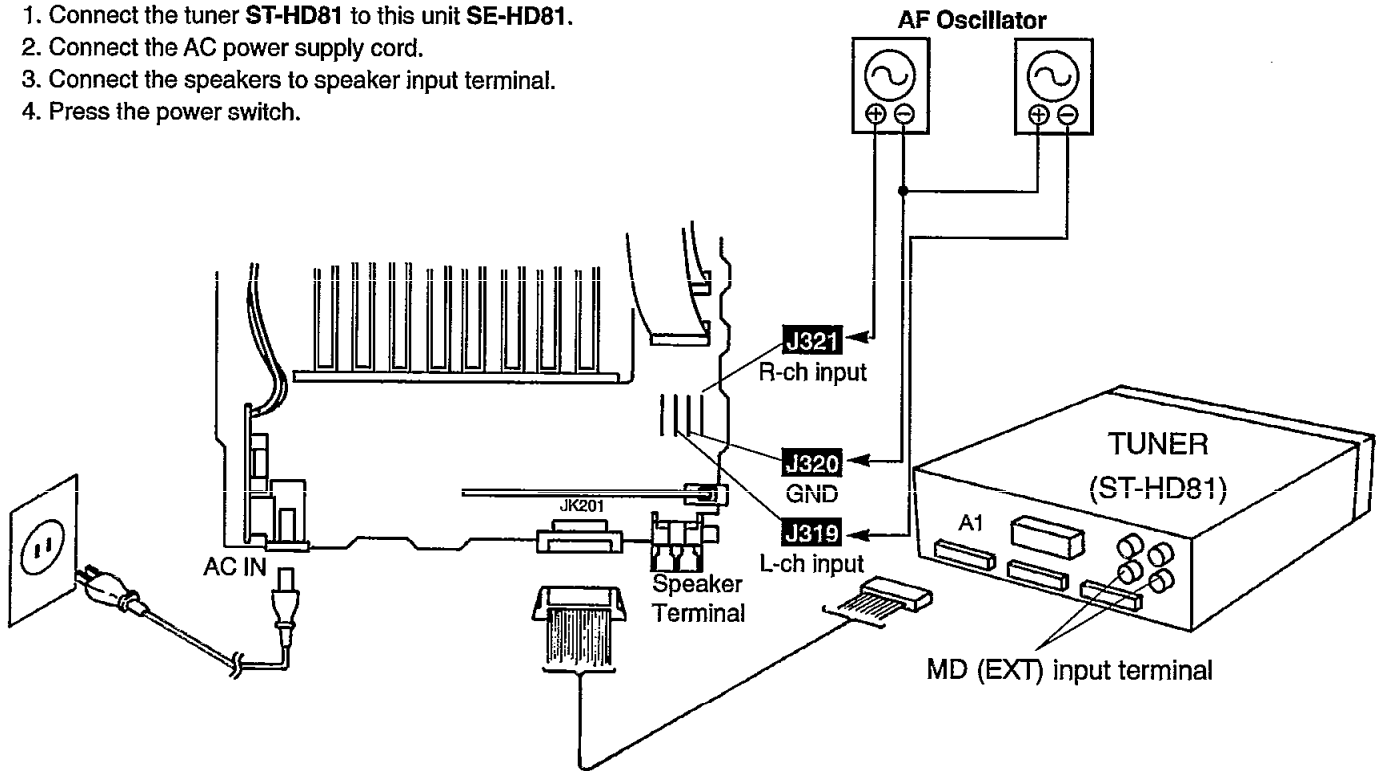

## ■ Type Illustration of ICs, Transistors and Diodes

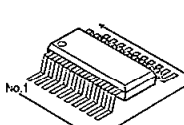
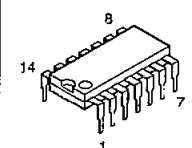
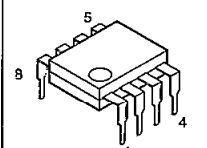
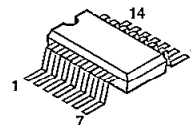
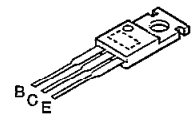
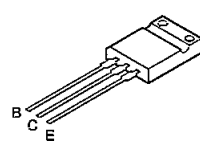
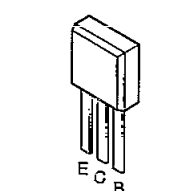
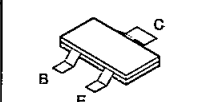
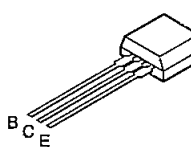
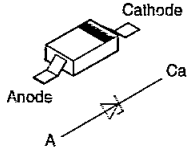
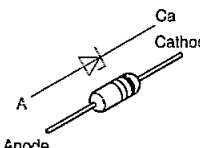
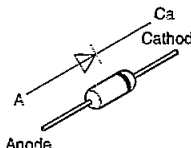
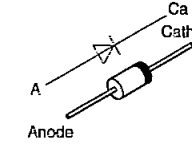
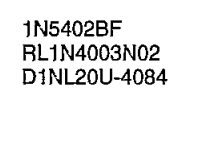
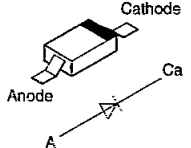
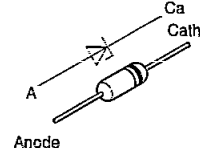
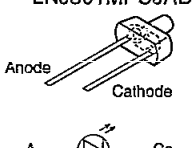
<table border="1"> <tr><td>M5218AFPE3</td><td>8PIN</td></tr> <tr><td>M5219FPTA</td><td>8PIN</td></tr> <tr><td>TC7WU04FT12L</td><td>8PIN</td></tr> <tr><td>TC7W08FTE12L</td><td>8PIN</td></tr> <tr><td>TC9215AFEL</td><td>16PIN</td></tr> </table> 	M5218AFPE3	8PIN	M5219FPTA	8PIN	TC7WU04FT12L	8PIN	TC7W08FTE12L	8PIN	TC9215AFEL	16PIN	<p>IR2112</p> 	<p>NJM2114D</p> 	<p>TC74HC00AFT1 TC74HC74AFEL</p> 	<p>IRFI510G</p> 
M5218AFPE3	8PIN													
M5219FPTA	8PIN													
TC7WU04FT12L	8PIN													
TC7W08FTE12L	8PIN													
TC9215AFEL	16PIN													
<p>2SD2137PQTA</p> 	<p>2SC3312RSTA 2SC3311AIRTA UN4111AITA UN4115TA</p> 	<p>2SB1218ARTX 2SB792RSTTX 2SD1819ARTX</p> 	<p>2SD2144STA</p> 	<p>MA8033LTX</p> 										
<p>MA4051MTA</p> 	<p>MA165TA</p> 	<p>1N5402BF RL1N4003N02 D1NL20U-4084</p> 	<p>MA111TX</p> 	<p>MA185TA</p> 										
<p>MA4120HTA MA4150HTA MA4240MTA MA4300MTA</p> 	<p>LNJ201LPQJA LNJ301MPUJAD</p> 													

**Schematic Diagram** (See parts list on pages 23 ~ 25.)

	Page
<b>A</b> OPERATION CIRCUIT .....	13, 14
<b>B</b> HEADPHONES JACK CIRCUIT .....	13
<b>C</b> PDM CIRCUIT .....	14
<b>D</b> MAIN CIRCUIT .....	15, 16
<b>E</b> POWER SUPPLY CIRCUIT .....	17
<b>F</b> INPUT/OUTPUT TERMINAL CIRCUIT .....	17
<b>G</b> POWER TRANSFORMER CIRCUIT .....	17
<b>H</b> AC IN TERMINAL CIRCUIT .....	17

● This schematic diagram may be modified at any time with the development of new technology.

**Notes:**



- S801 : Power "STANDBY  $\phi$  /ON" switch (POWER, STANDBY  $\phi$  /ON)
- S802 : Source direct switch (SOURCE DIRECT)
- S803 : Vocal presence switch (VOCAL PRESENCE)

● Indicated voltage values are the standard values for the unit measured by the DC electronic circuit tester (high-impedance) with the chassis taken as standard. Therefore, there may exist some errors in the voltage values, depending on the internal impedance of the DC circuit tester.  
No mark: Power ON

● Important safety notice:  
Components identified by  $\triangle$  mark have special characteristics important for safety.  
Furthermore, special parts which have purposes of fire-retardant (resistors), high-quality sound (capacitors), low-noise (resistors), etc. are used. When replacing any of components, be sure to use only manufacturer's specified parts shown in the parts list.

● **Caution!**  
IC and LSI are sensitive to static electricity.  
Secondary trouble can be prevented by taking care during repair.  
Cover the parts boxes made of plastics with aluminum foil.  
Ground the soldering iron.  
Put a conductive mat on the work table.  
Do not touch the legs of IC or LSI with the fingers directly.

● **Voltage and signal line**

-  : Positive voltage line
-  : Positive voltage line
-  : Source signal line

**A** OPERATION CIRCUIT (P.C.Board: on page 18)

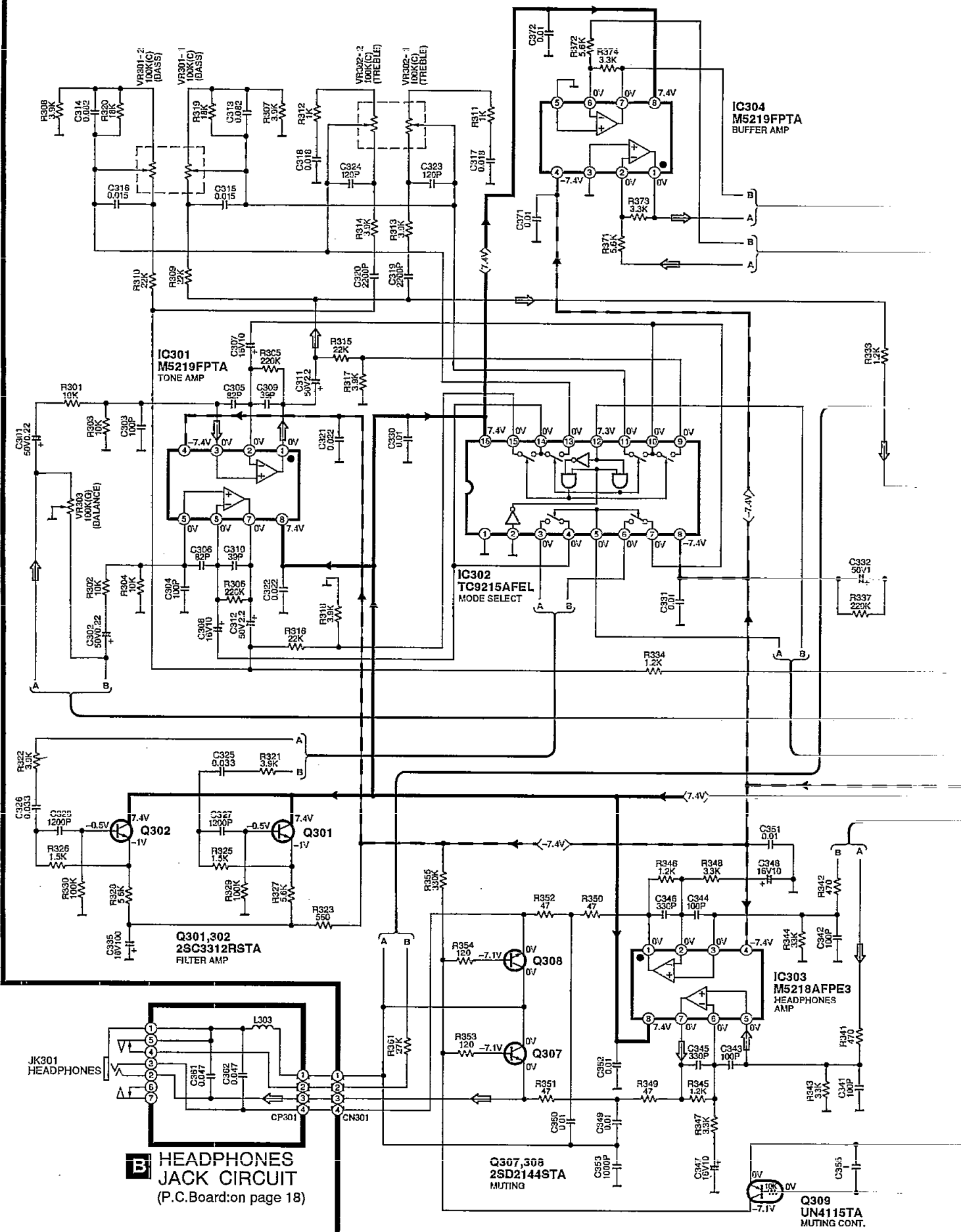

**B** HEADPHONES JACK CIRCUIT (P.C.Board: on page 18)

C PDM CIRCUIT (P.C.Board: on page 20)

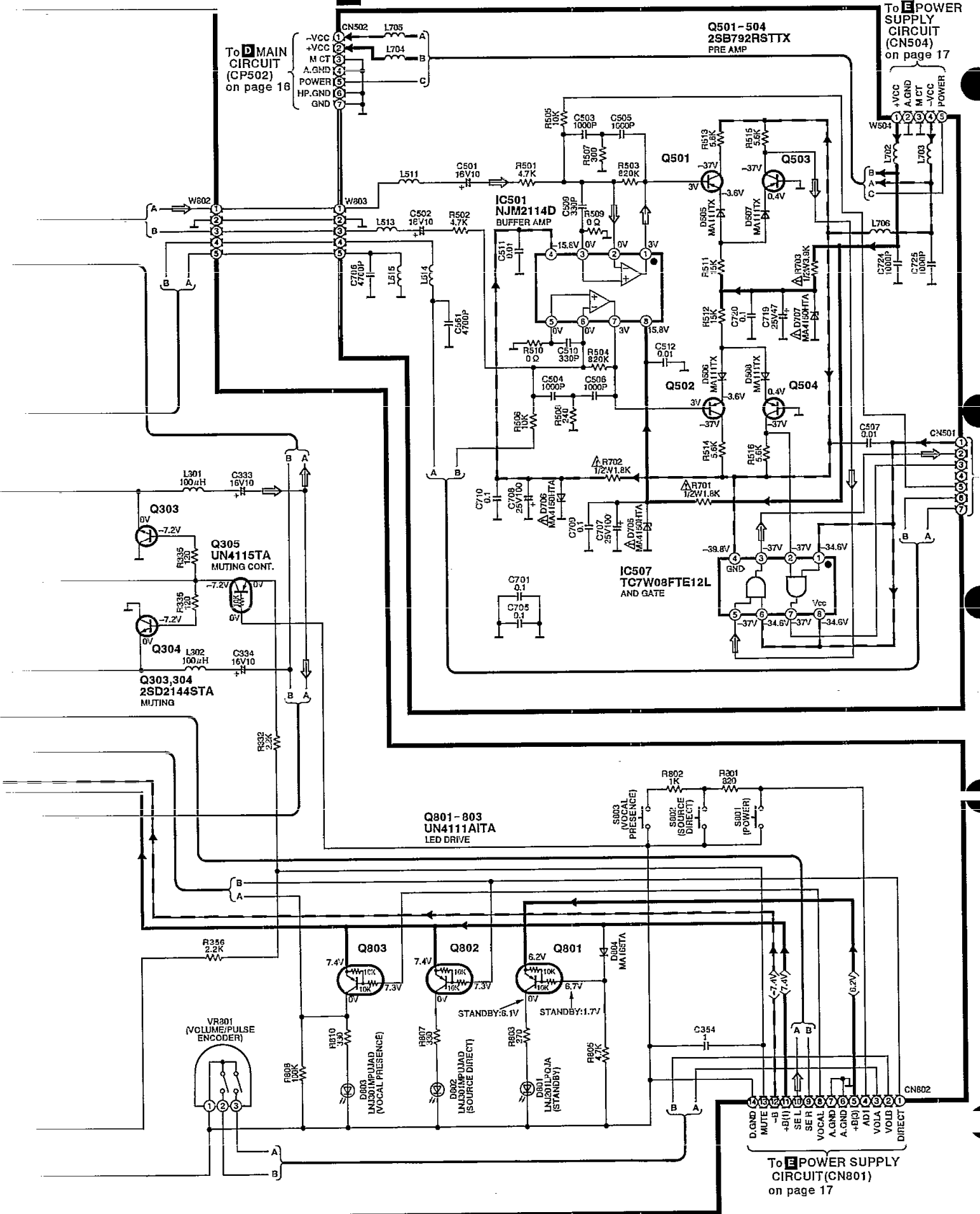

To E POWER SUPPLY CIRCUIT (CN504) on page 17

To E POWER SUPPLY CIRCUIT (CN801) on page 17

**D** MAIN CIRCUIT (P.C.Board: on page 19)

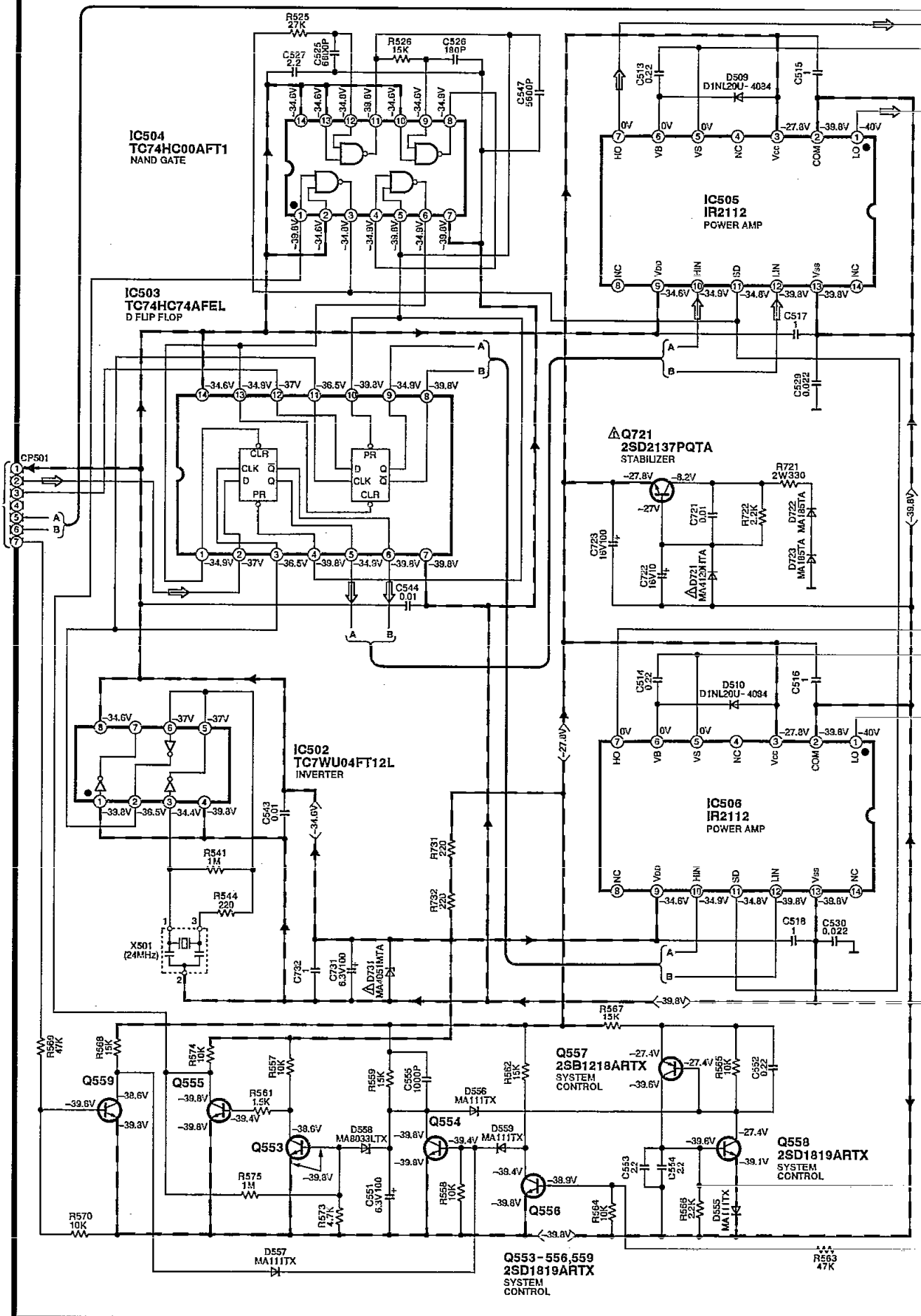

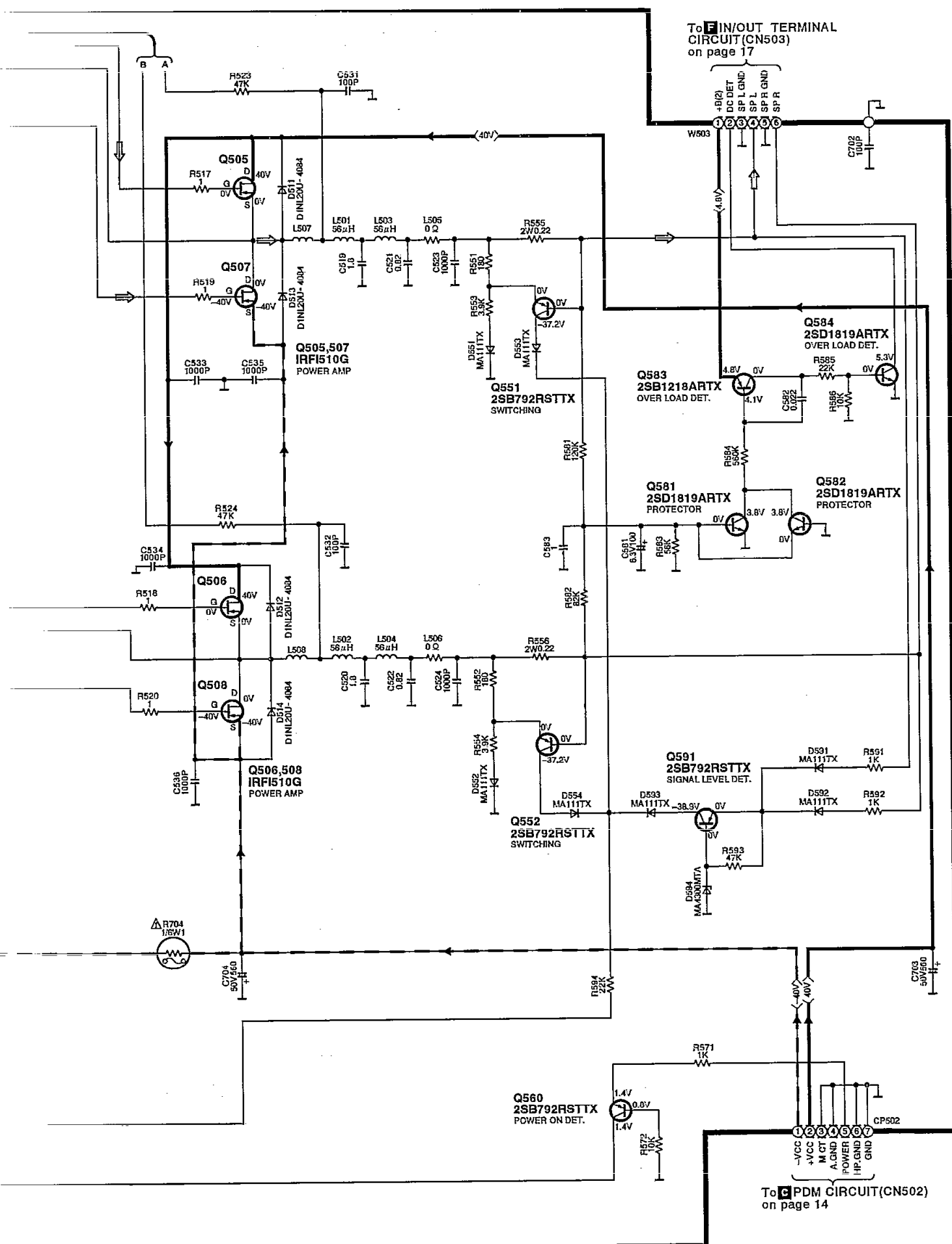



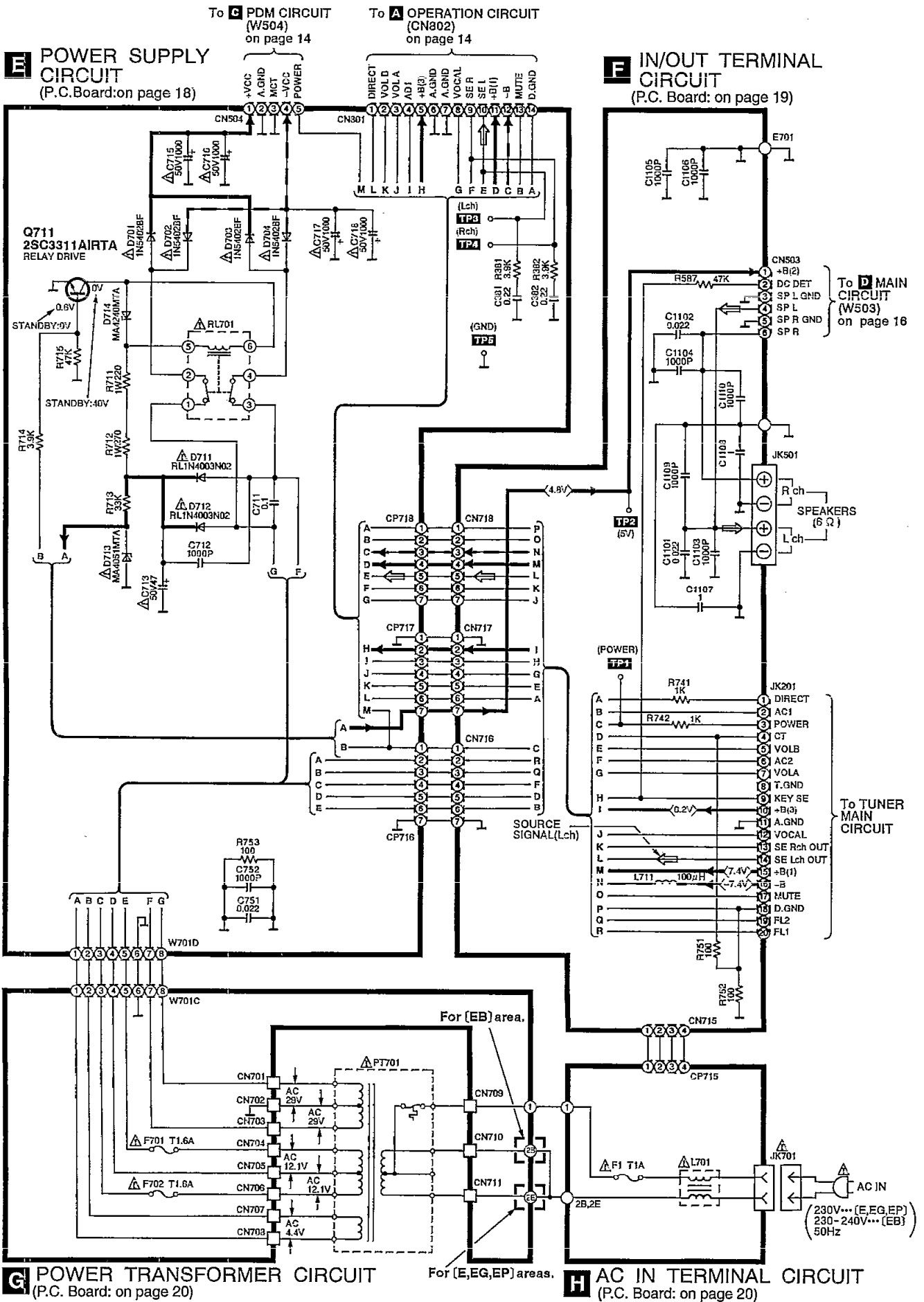



**D** MAIN P.C.B.

**F** IN/OUT  
TERMINAL P.C.B.

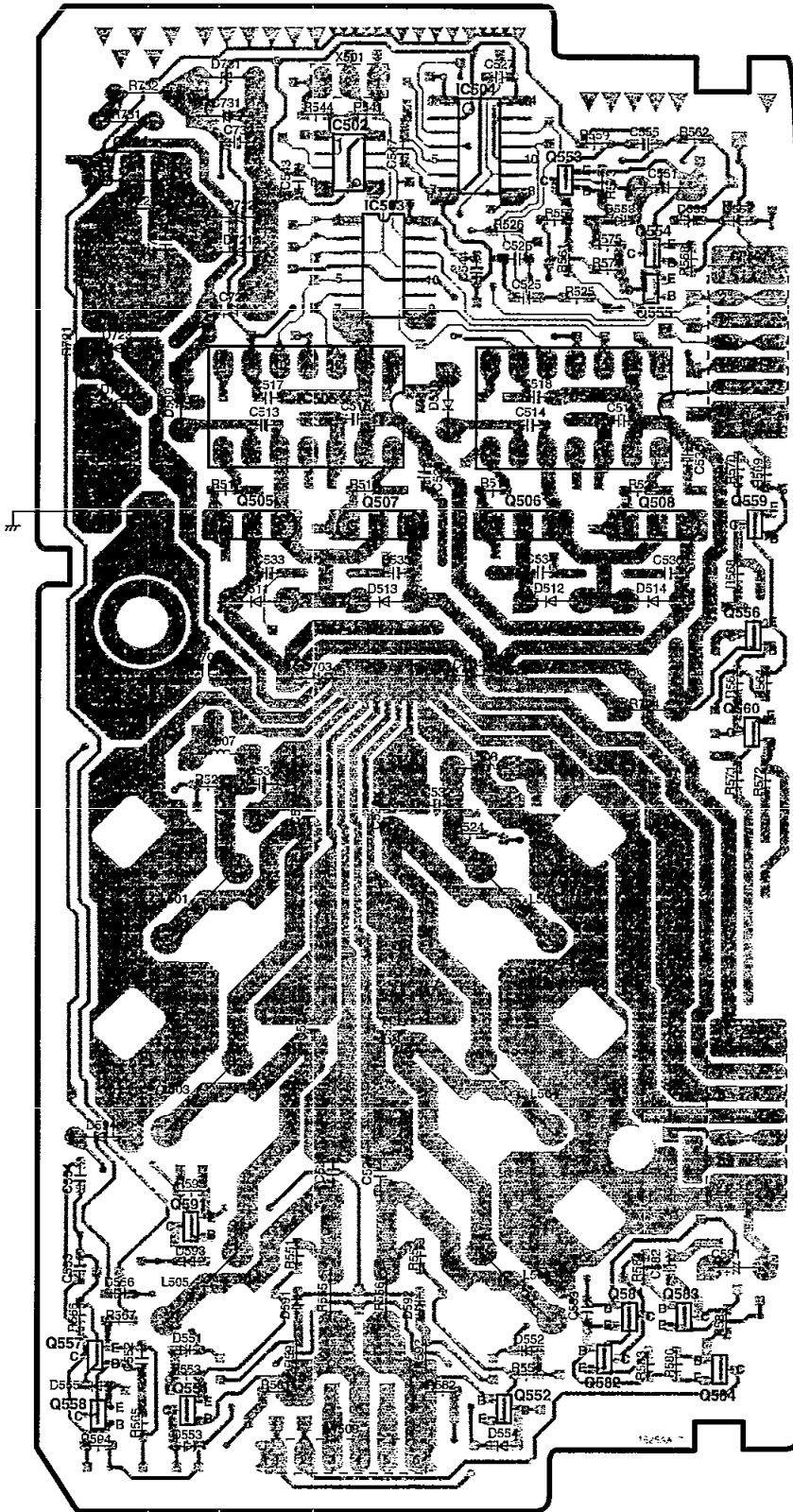

(REP2293B-M)

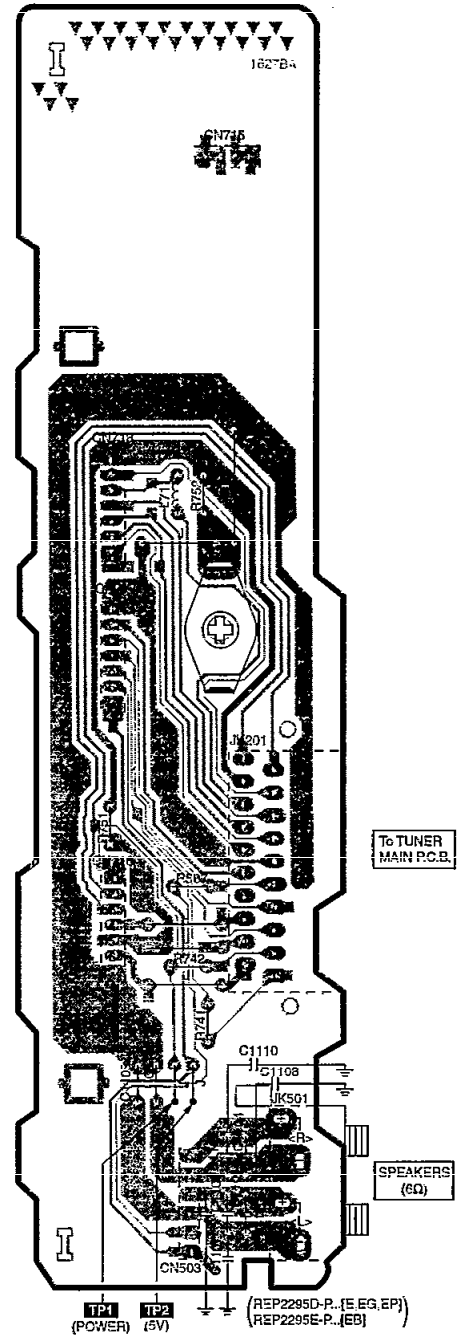

To TUNER  
MAIN P.C.B.

SPEAKERS  
(6Ω)

TP1 (POWER) TP2 (5V)  
(REP2295D-P, [E, EG, EP])  
(REP2295E-P, [EB])

**C** PDM P.C.B.

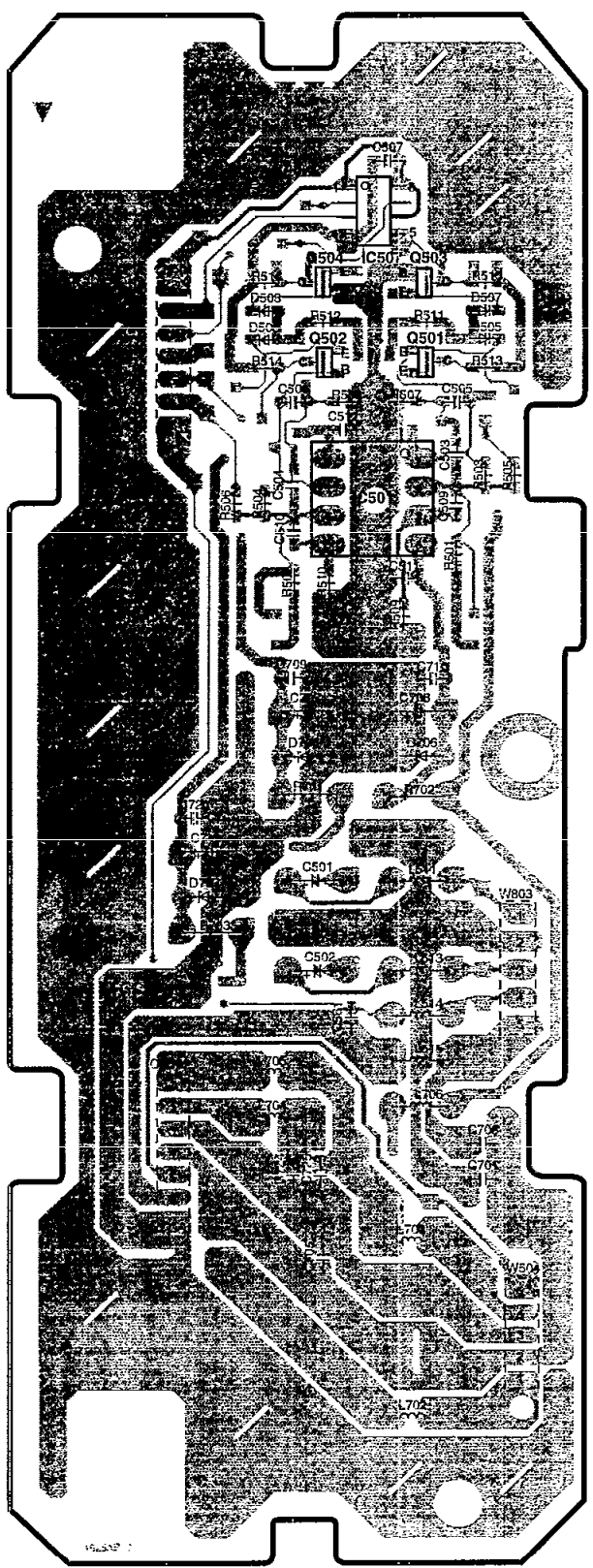

(REP2293B-M)

**G** POWER TRANSFORMER P.C.B.

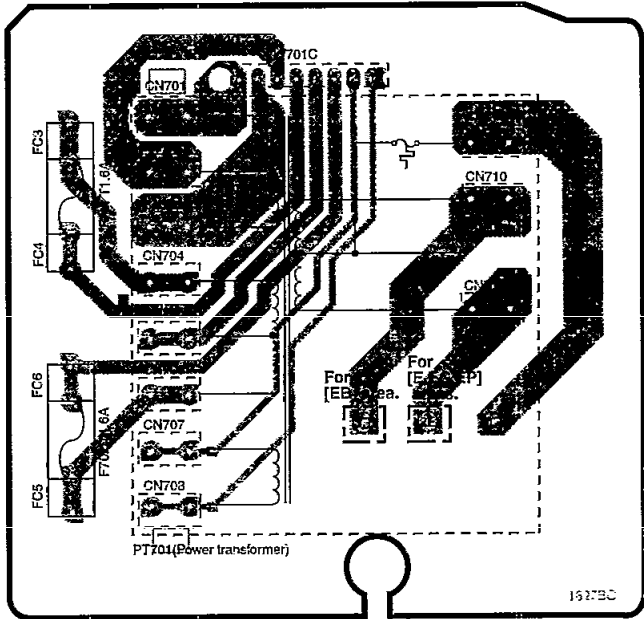

(REF2295D-P..[E,EG,EP])  
(REF2295E-P..[EB])

**H** AC IN TERMINAL P.C.B.

**AC IN**  
(230V.....[E,EG,EP])  
(230-240V...[EB])  
50Hz

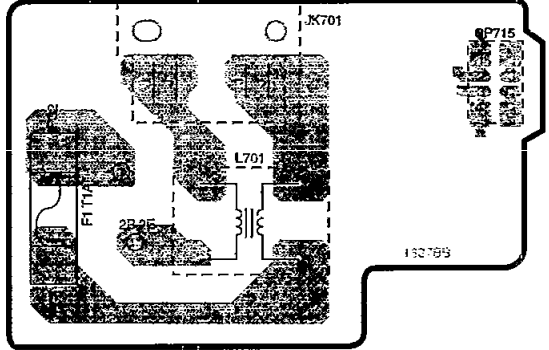

(REF2295D-P..[E,EG,EP])  
(REF2295E-P..[EB])

Block Diagram

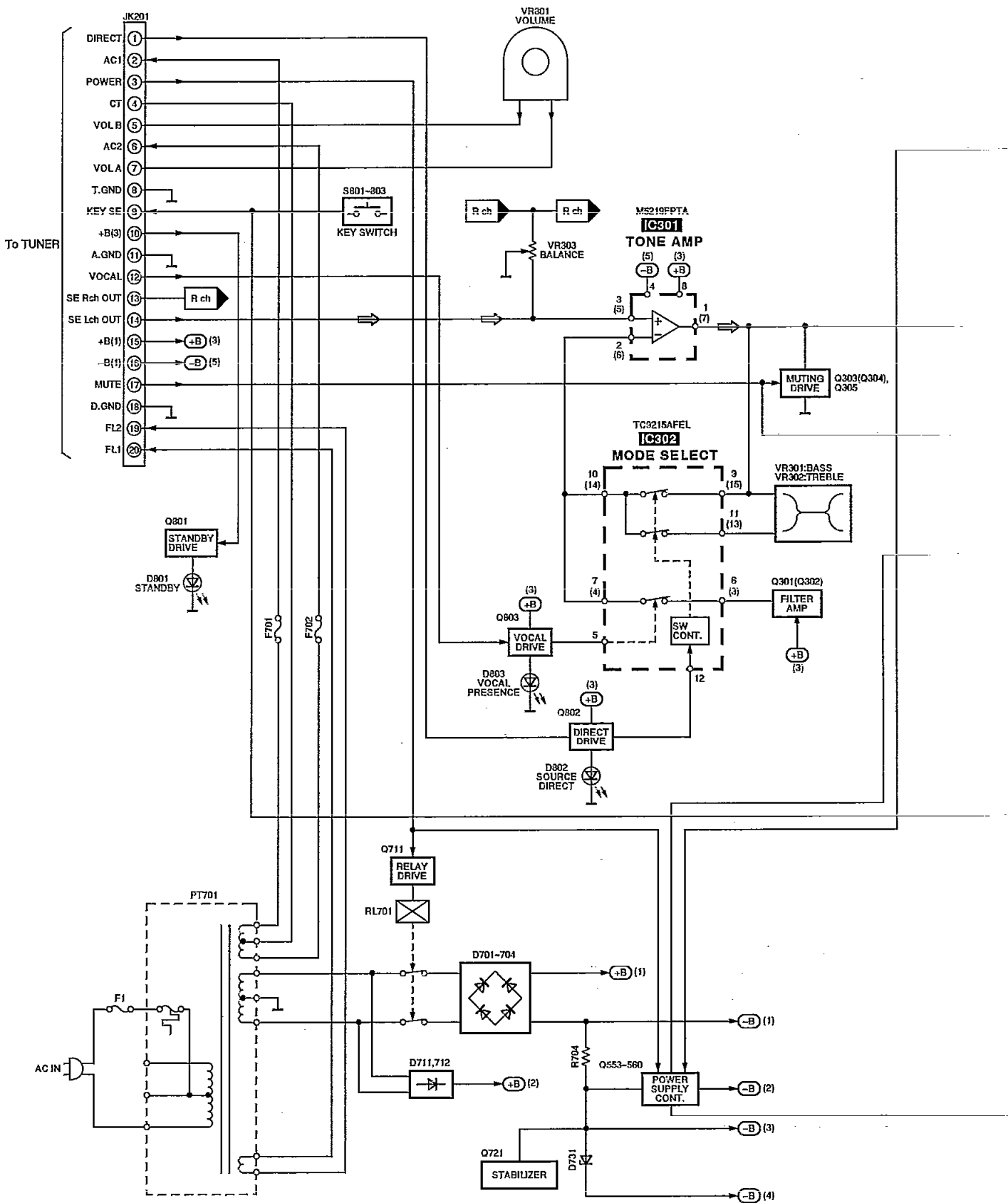

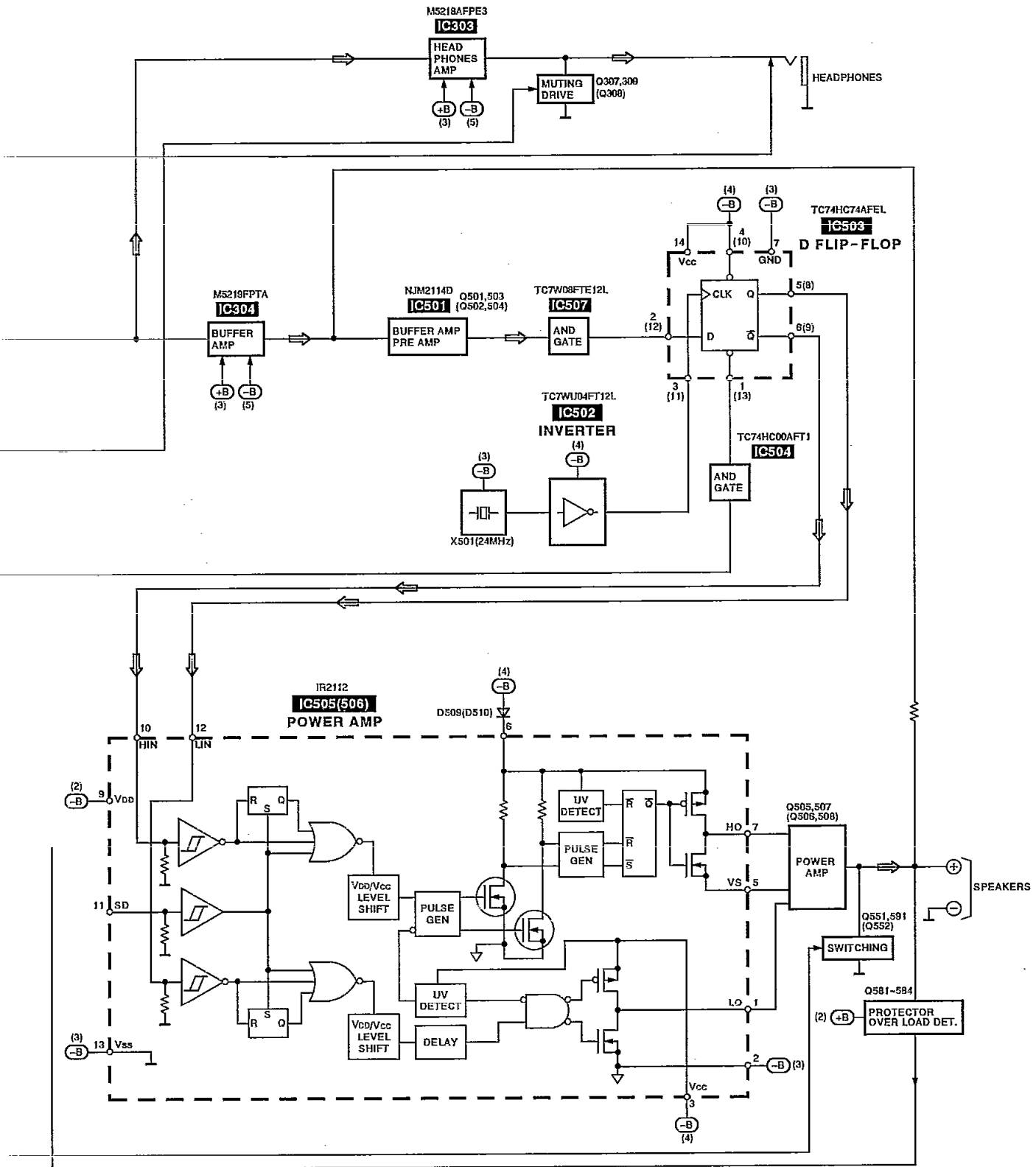

Notes:  
 1) ⇒ :SOURCE SIGNAL  
 2) { } INDICATES PIN NO. OF RIGHT CHANNEL

# Replacement Parts List

## Notes: \* Important safety notice:

Components identified by  $\Delta$  mark have special characteristics important for safety.

Furthermore, special parts which have purposes of fire-retardant (resistors), high-quality sound (capacitors), low-noise (resistors), etc. are used. When replacing any of components, be sure to use only manufacturer's specified parts shown in the parts list.

\* The parenthesized indications in the Remarks columns specify the areas. (Refer to the cover page for area.)

Parts without these indications can be used for all areas.

\* Remote Control Ass'y: Supply period for three years from termination of production.

\* Capacity values are in microfarads ( $\mu$ F) unless specified otherwise,  
P=Pico-farads (pF) F=Farads (F)

\* Resistance values are in ohms, unless specified otherwise, 1K=1,000 (OHM), 1M=1,000k (OHM)

\* "<IA>, <IB>, <IC>, <ID>, <IE>" marks in Remarks indicate language of instruction manual.

[<IA>: French/Spanish/Swedish, <IB>: German/Italian/Dutch, <IC>: Danish, <ID>: English, <IE>: Russian/Czeco/Polish]

Ref.No.	Part No.	Part Name & Description	Pcs	Remarks
1	RHD30673-K	SCREW	4	
2	XTBS3+10JFZ1	SCREW	1	
3	XTBS3+8JFZ1	SCREW	17	
4	RSC0457	SHIELD BRACKET	1	
5	RKA0076-N	FOOT	4	
6	REZ0900	FLAT CABLE (CH801, 802/14P)	1	
7	RGW0247A-N	VOLUME KNOB	1	
8	REZ0902	CONNECTOR ASS'Y (5P) (W802)	1	
9	PWNO191	P. C. B. HOLDER	1	
10	PWNO203	P. C. B. HOLDER	4	
11	XTB3+6G	SCREW	4	
12	RGK0809-1M	SIDE PANEL (R)	1	
13	RGK0808-1M	SIDE PANEL (L)	1	
14	RLBT3101-D	FERRITE CORE	1	
15	RLBT4001-D	FERRITE CORE	1	
16	RLB0010	FERRITE CORE	1	
17	RWZ0397	BARRIER	1	
18	XTB3+16JFZ	SCREW	1	
19	RWFO236	SHEET	1	
20	PJS2A1305	CABLE HOLDER (W504)	1	
21	RWRO985-X	EDGE HOLDER	1	
22	SNE185-2	P. C. B. SUPPORT	1	
23	XTBS26+8J	SCREW	4	
24	SNE4021-1	NUT	1	
25	RHD26016	SCREW	1	
26	XTB3+6JFZ	SCREW	22	
27	RGW0198-S	ADJUSTMENT KNOB	3	
28	RGU1393-Q	BUTTON	1	
29	RFKGEHD81E-N	FRONT PANEL ASS'Y	1	
30	PGK0810-N3	SIDE ORNAMENT (L)	1	
31	RGK0811-N3	SIDE ORNAMENT (R)	1	
32	RGK0815-N	VOLUME ORNAMENT	1	
33	RGL0333-2Q	PANEL LIGHT	1	
34	RGU1392-S	BUTTON	1	
35	REZ0901	CONNECTOR ASS'Y	1	
36	REZ0903	FLAT CABLE (8P) (W701)	1	
37	PJS1A5506	CABLE HOLDER (W503)	1	
A1	RQT4304-E	INSTRUCTION MANUAL	1	(E) <IA>

Ref.No.	Part No.	Part Name & Description	Pcs	Remarks
A1	RQT4305-D	INSTRUCTION MANUAL	1	(EG) <IB>
A1	RQT4306-H	INSTRUCTION MANUAL	1	(EG) <IC>
A1	RQT4307-B	INSTRUCTION MANUAL	1	(EB) (EP) <ID>
A1	RQT4308-R	INSTRUCTION MANUAL	1	(EP) <IE>
A2	REX0608	FLAT CABLE (SHORT) (20P)	1	
A3	REX0812	FLAT CABLE (LONG) (19P)	1	
A4	REX0813	FLAT CABLE (MIDDLE) (15P)	1	
A5	RFA0737-R	SPEAKER CORD UNIT	1	
A6	RJA0019-X	AC POWER SUPPLY CORD	1	(E) (EG) (EP)
A6	RJA0053-1X	AC POWER SUPPLY CORD	1	(EB)
A7	RAK-CH214WH	REMOTE CONTROL TRANSMITTER	1	
A7-1	RKK0057-K	BATTERY COVER FOR R.C.T.	1	
A8	RQA0117	WARRANTY CARD	1	(E) (EB) (EG)
A9	RQCB0169	SERVICENTER LIST	1	(E) (EB) (EG)
A10	RSA0007	FM INDOOR ANTENNA	1	
A11	RSA0021	AM LOOP ANTENNA	1	
A12	RQCA0600	QUICK SET UP GUIDE	1	(EB)
A13	SJP9009	ANTENNA PLUG ADAPTOR	1	(EB)
C301, 02	ECEA1HKAR22B	50V 0.22U	2	
C303, 04	ECBT1H101KB5	50V 100P	2	
C305, 06	ECBT1H820KB5	50V 82P	2	
C307, 08	RCE1CKA100BG	16V 10U	2	
C309, 10	ECBT1H390J5	50V 39P	2	
C311, 12	ECEA1HKA2R2B	50V 2.2U	2	
C313, 14	ECQV1H823JW3	50V 0.082U	2	
C315, 16	ECQB1H153JF3	50V 0.015U	2	
C317, 18	ECQB1H183JF3	50V 0.018U	2	
C319, 20	ECQB1H222JF3	50V 2200P	2	
C321, 22	ECBT1E223ZF5	25V 0.022U	2	
C323, 24	ECBT1H121KB5	50V 120P	2	
C325, 26	ECQV1H333JW3	50V 0.033U	2	
C327, 28	ECQB1H122JF3	50V 1200P	2	
C330, 31	ECBT1E103ZF5	25V 0.01U	2	
C332	ECEA1HKA010B	50V 1U	1	
C333, 34	RCE1CKA100BG	16V 10U	2	
C335	RCE1JKA101BG	16V 100U	1	
C341-44	ECBT1H101KB5	50V 100P	4	
C345, 46	ECBT1H331KB5	50V 330P	2	
C347, 48	RCE1CKA100BG	16V 10U	2	
C349-52	ECBT1E103ZF5	25V 0.01U	4	
C353	ECBT1H102KB5	50V 1000P	1	
C354, 55	ECBT1C105ZF5	16V 1U	2	
C361, 62	ECBT1H473ZF5	50V 0.047U	2	
C371, 72	ECBT1E103ZF5	25V 0.01U	2	
C381, 82	ECQV1H224JW3	50V 0.22U	2	
C501, 02	RCE1CKA100BG	16V 10U	2	
C503-06	ECUV1H102KBN	50V 1000P	4	
C507	ECUV1E103ZFN	25V 0.01U	1	
C509, 10	ECUV1H331KBN	50V 330P	2	
C511, 12	ECUV1E103ZFN	25V 0.01U	2	
C513, 14	ECUV1E224ZFN	25V 0.22U	2	
C515-18	ECUVNC105ZFN	16V 1U	4	
C519, 20	ECQV1H185JL3	50V 1.8U	2	
C521, 22	ECQV1H824JW3	50V 0.82U	2	
C523, 24	ECKR1H102KB5	50V 1000P	2	
C525	ECUV1H682KBN	50V 6800P	1	
C526	ECUV1H181KCN	50V 180P	1	
C527	ECUVNC225ZFN	16V 2.2U	1	
C529, 30	ECUV1H223ZFN	50V 0.022U	2	
C531, 32	ECUV2H101JCM	500V 100P	2	
C533-36	ECUV1H102KBN	50V 1000P	4	
C543, 44	ECUV1E103ZFN	25V 0.01U	2	
C547	ECUV1H562KBN	50V 5600P	1	
C551	ECEA0JKA101B	6.3V 100U	1	
C552	ECUV1E224ZFN	25V 0.22U	1	
C553, 54	ECUVNC225ZFN	16V 2.2U	2	
C555	ECUV1H102KBN	50V 1000P	1	
C561	ECUV1H472KBN	50V 4700P	1	
C581	ECEA0JKA101B	6.3V 100U	1	
C582	ECUV1E223ZFN	25V 0.022U	1	
C583	ECUVNC105ZFN	16V 1U	1	
C701	ECUV1E104ZFN	25V 0.1U	1	
C702	ECUV1H101KCN	50V 100P	1	
C703, 04	EEUF1H561E	50V 560U	2	

Ref.No.	Part No.	Part Name & Description	Pcs	Remarks	Ref.No.	Part No.	Part Name & Description	Pcs	Remarks
C705	ECUVIE104ZFN	25V 0.1U	1		△ JK701	SJS9236	JACK, AC INLET	1	
C706	ECUVI1472KBN	50V 4700P	1						
C707, 08	ECA1EM101B	25V 100U	2		L301, 02	ELEXT101KA9	COIL	2	
C709, 10	ECUVIE104ZFN	25V 0.1U	2		L303	RL1500050T-Y	COIL	1	
C711	ECQE1104KF3	100V 0.1U	1		L501	RLQT560K	COIL	1	
C712	ECKR2H102ZF5	500V 1000P	1		L502	RLQT560K1	COIL	1	
△ C713	ECA1HW470B	50V 47U	1		L503	RLQT560K	COIL	1	
△ C715-18	EEUPL1H102LE	50V 1000U	4		L504	RLQT560K1	COIL	1	
C719	ECEA1EKA470B	25V 47U	1		L505, 06	ERD25V0R00T	COIL	2	
C720	ECUVIE104ZFN	25V 0.1U	1		L507, 08	BL02RN1R62T2	COIL	2	
C721	ECUVIE103ZFN	25V 0.01U	1		L511	BL02RN2R62T4	COIL	1	
C722	RCE1CKA100BG	16V 10U	1		L513-15	BL02RN2R62T4	COIL	3	
C723	ECEA1CKA101B	16V 100U	1		△ L701	RLQ2271W	COIL	1	
C724, 25	ECUVI1H102KBN	50V 1000P	2		L702-06	BL02RN2R62T4	COIL	5	
C731	ECEA0JKA101B	6.3V 100U	1		L711	ELEXT101KA9	COIL	1	
C732	ECUVNC105ZFN	16V 1U	1						
C751	ECBT1E223ZF5	25V 0.022U	1		P1	RPG3196	PACKING CASE (AMPLIF./DECK)	2	
C752	ECBT1H102KB5	50V 1000P	1		P1	RPG3529	PACKING CASE (CD/TUNER)	2	
C1101, 02	ECBT1E223ZF5	25V 0.022U	2		P2	RPN0970-3	CUSHION (AMPLIF/ER/DECK)	2	
C1103-06	ECBT1H102KB5	50V 1000P	4		P2	RPN0971-3	CUSHION (CD/TUNER)	2	
C1107, 08	ECBT1C105ZF5	16V 1U	2		P3	SPP740	PROTECTION BAG (UNIT)	4	
C1109, 10	ECBT1H102KB5	50V 1000P	2		P4	RPG3835	PACKING CASE (SYSTEM)	1 (E)	
					P4	RPG3836	PACKING CASE (SYSTEM)	1 (EG)	
					P4	RPG3958	PACKING CASE (SYSTEM)	1 (EB)	
					P4	RPG3961	PACKING CASE (SYSTEM)	1 (EP)	
					P5	RPQ0771	PAD	1	
					P6	RPF0139	PROTECTION BAG (F. B.)	1	
△ CN301	RJT057W004-1	CONNECTOR (4P)	1		△ PT701	RTP2W6B011	POWER TRANSFORMER	1	
CN501, 02	RJT057W007-1	CONNECTOR (7P)	2						
CN503	RJS1A660G	CONNECTOR (6P)	1		Q301, 02	ZSC3312RSTA	TRANSISTOR	2	
CN504	RJS5T7ZA	CONNECTOR (5P)	1		Q303, 04	ZSD2144STA	TRANSISTOR	2	
CN701-11	RJS1A1101T1	CONNECTOR (1P)	11		Q305	UN4115TA	TRANSISTOR	1	
CN715	RJT057W004-1	CONNECTOR (4P)	1		Q307, 08	ZSD2144STA	TRANSISTOR	2	
CN716-18	RJT057W007-1	CONNECTOR (7P)	3		Q309	UN4115TA	TRANSISTOR	1	
CN801, 02	RJS1A6714	CONNECTOR (14P)	2		Q501-04	ZSB792RSTTX	TRANSISTOR	4	
					Q505-08	1RF1510G	TRANSISTOR	4	
CP301	RJU057W004	SOCKET (4P)	1		Q551, 52	ZSB792RSTTX	TRANSISTOR	2	
CP501, 02	RJU057W007	SOCKET (7P)	2		Q553-56	ZSD1819ARTX	TRANSISTOR	4	
CP715	RJU057W004	SOCKET (4P)	1		Q557	ZSB1218RTW	TRANSISTOR	1	
CP716-18	RJU057W007	SOCKET (7P)	3		Q558, 59	ZSD1819ARTX	TRANSISTOR	2	
					Q560	ZSB792RSTTX	TRANSISTOR	1	
D505-08	WA111TX	DIODE	4		Q581, 82	ZSD1819ARTX	TRANSISTOR	2	
D509-14	D1ML20U-4084	DIODE	6		Q583	ZSB1218RTW	TRANSISTOR	1	
D551-57	WA111TX	DIODE	7		Q584	ZSD1819ARTX	TRANSISTOR	1	
D558	WA8033LTX	DIODE	1		Q591	ZSB792RSTTX	TRANSISTOR	1	
D559	WA111TX	DIODE	1		Q711	ZSC3311A1RTA	TRANSISTOR	1	
D591-93	WA111TX	DIODE	3		△ Q721	ZSD2137PQTA	TRANSISTOR	1	
D594	WA4300MTA	DIODE	1		Q801-03	UN4111	TRANSISTOR	3	
△ D701-04	1N5402BF	DIODE	4						
△ D705-07	WA4150W	DIODE	3		R301	ERDS2FJ103	1/4W 10K	1	
△ D711, 12	RL1N4003N02	DIODE	2		R302	ERDS2TJ103	1/4W 10K	1	
△ D713	WA4051MTA	DIODE	1		R303, 04	ERDS2FJ103	1/4W 10K	2	
D714	WA4240MTA	DIODE	1		R305, 06	ERDS2FJ224	1/4W 220K	2	
△ D721	WA4120HTA	DIODE	1		R307, 08	ERDS2FJ392	1/4W 3.9K	2	
D722, 23	WA185TA	DIODE	2		R309, 10	ERDS2TJ223T	1/4W 22K	2	
△ D731	WA4051MTA	DIODE	1		R311, 12	ERDS2TJ102	1/4W 1K	2	
D801	LNJ201LPQJA	L. E. D.	1		R313, 14	ERDS2FJ392	1/4W 3.9K	2	
D802, 03	LNJ301MPUJAD	L. E. D.	2		R315, 16	ERDS2TJ223T	1/4W 22K	2	
D804	WA165	DIODE	1		R317, 18	ERDS2FJ392	1/4W 3.9K	2	
					R319, 20	ERDS2FJ183	1/4W 18K	2	
△ F1	XBA2C10TB0	FUSE	1		R321, 22	ERDS2FJ392	1/4W 3.9K	2	
△ F701, 02	XBA2C16TB0	FUSE	2		R323	ERDS2TJ561T	1/4W 560	1	
					R325, 26	ERDS2TJ152T	1/4W 1.5K	2	
FC1-C6	EYF52BC	FUSE HOLDER	6		R327, 28	ERDS2TJ562	1/4W 5.6K	2	
					R329, 30	ERDS2TJ104	1/4W 100K	2	
IC301	W5219FP7A	IC	1		R332	ERDS2TJ222	1/4W 2.2K	1	
IC302	TC9215AFEL	IC	1		R333, 34	ERDS2TJ122T	1/4W 1.2K	2	
IC303	W5218AFP23	IC	1		R335, 36	ERDS2TJ121T	1/4W 120	2	
IC304	W5219FP7A	IC	1		R337	ERDS2FJ224	1/4W 220K	1	
IC501	NJW2114D	IC	1		R341, 42	ERDS2TJ471T	1/4W 470	2	
IC502	TC7WU04FT12L	IC	1		R343, 44	ERDS2TJ333T	1/4W 33K	2	
IC503	TC74HC74AFEL	IC	1		R345, 46	ERDS2TJ122T	1/4W 1.2K	2	
IC504	TC74HC00AFT1	IC	1		R347, 48	ERDS2TJ333T	1/4W 3.3K	2	
IC505, 06	IR2112	IC	2		R349-52	ERDS2FJ470	1/4W 47	4	
IC507	TC7W08FTE12L	IC	1						
JK201	RJT065K20	JACK, SYSTEM	1						
JK301	RJ137TND1-C	JACK, HEADPHONES	1						
JK501	RJR0054	JACK, SPEAKERS	1						



Ref.No.	Part No.	Part Name & Description	Pcs	Remarks	Ref.No.	Part No.	Part Name & Description	Pcs	Remarks
R353, 54	ERDS2TJ121T	1/4W 120	2		VR303	EVJ02QF04G15	V. R	1	
R355	ERDS2TJ334T	1/4W 330K	1		VR801	EVQWQAF2524B	V. R	1	
R356	ERDS2FJ222	1/4W 2.2K	1						
R361	ERDS2TJ273T	1/4W 27K	1		X501	EF0EC2405T4	OSCILLATOR	1	
R371, 72	ERDS2TJ562	1/4W 5.6K	2						
R373, 74	ERDS2TJ332T	1/4W 3.3K	2						
R381, 82	ERDS2FJ392	1/4W 3.9K	2						
R501, 02	ERJ6GEYJ472V	1/10W 4.7K	2						
R503, 04	ERJ6GEYJ824V	1/10W 820K	2						
R505, 06	ERJ6GEYJ103V	1/10W 10K	2						
R507	ERJ6GEYJ301V	1/10W 300	1						
R508	ERJ6GEYJ241V	1/10W 240	1						
R509, 10	ERJ6GEY0R00Z	1/10W 0	2						
R511, 12	ERJ6GEYJ153V	1/10W 15K	2						
R513-16	ERJ6GEYJ562V	1/10W 5.6K	4						
R517-20	ERJ6GEYJ180V	1/10W 1	4						
R523, 24	ERJ6GEYJ473V	1/10W 47K	2						
R525	ERJ6GEYJ273V	1/10W 27K	1						
R526	ERJ6GEYJ153V	1/10W 15K	1						
R541	ERJ6GEYJ105V	1/10W 1M	1						
R544	ERJ6GEYJ221V	1/10W 220	1						
R551, 52	ERJ6GEYJ181V	1/10W 180	2						
R553, 54	ERJ6GEYJ392V	1/10W 3.9K	2						
R555, 56	ERF2EXKR22V	2W 0.22	2						
R557, 58	ERJ6GEYJ103V	1/10W 10K	2						
R559	ERJ6GEYJ153V	1/10W 15K	1						
R561	ERJ6GEYJ152V	1/10W 1.5K	1						
R562	ERJ6GEYJ153V	1/10W 15K	1						
R563	ERJ6GEYJ473V	1/10W 47K	1						
R564, 65	ERJ6GEYJ103V	1/10W 10K	2						
R566	ERJ6GEYJ222V	1/10W 2.2K	1						
R567, 68	ERJ6GEYJ153V	1/10W 15K	2						
R569	ERJ6GEYJ473V	1/10W 47K	1						
R570	ERJ6GEYJ103V	1/10W 10K	1						
R571	ERJ6GEYJ102Z	1/10W 1K	1						
R572	ERJ6GEYJ103V	1/10W 10K	1						
R573	ERJ6GEYJ472V	1/10W 4.7K	1						
R574	ERJ6GEYJ103V	1/10W 10K	1						
R575	ERJ6GEYJ105V	1/10W 1M	1						
R581	ERJ6GEYJ124V	1/10W 120K	1						
R582	ERJ6GEYJ823V	1/10W 82K	1						
R583	ERJ6GEYJ563V	1/10W 56K	1						
R584	ERJ6GEYJ564V	1/10W 560K	1						
R585	ERJ6GEYJ223V	1/10W 22K	1						
R586	ERJ6GEYJ103V	1/10W 10K	1						
R587	ERDS2TJ473T	1/4W 47K	1						
R591, 92	ERJ6GEYJ102Z	1/10W 1K	2						
R593	ERJ6GEYJ473V	1/10W 47K	1						
R594	ERJ6GEYJ223V	1/10W 22K	1						
▲ R701, 02	ERDS1FJ182	1/2W 1.8K	2						
▲ R703	ERDS1FJ392	1/2W 3.9K	1						
▲ R704	EPQ16RW1R0E	1/6W 1	1						
R711	ERGISJ221	1W 220	1						
R712	ERGISJ271	1W 270	1						
R713	ERDS2TJ333T	1/4W 33K	1						
R714	ERDS2FJ392	1/4W 3.9K	1						
R715	ERDS2TJ473T	1/4W 47K	1						
R721	ERC2S1331	2W 330	1						
R722	ERDS2FJ222	1/4W 2.2K	1						
R731, 32	ERDS2TJ221T	1/4W 220	2						
R741, 42	ERDS2FJ102	1/4W 1K	2						
R751-53	ERDS2FJ101	1/4W 100	3						
R801	ERDS2TJ821T	1/4W 820	1						
R802	ERDS2FJ102	1/4W 1K	1						
R803	ERDS2TJ271T	1/4W 270	1						
R805	ERDS2FJ472	1/4W 4.7K	1						
R807	ERDS2TJ331T	1/4W 330	1						
R808	ERDS2FJ104	1/4W 100K	1						
R810	ERDS2TJ331T	1/4W 330	1						
▲ RL701	RSY0013M-0	RELAY	1						
S801-03	EVQPTD05Q	SW	3						
VR301, 02	EVJYA1F04C15	V. R	2						

# Cabinet Parts Location

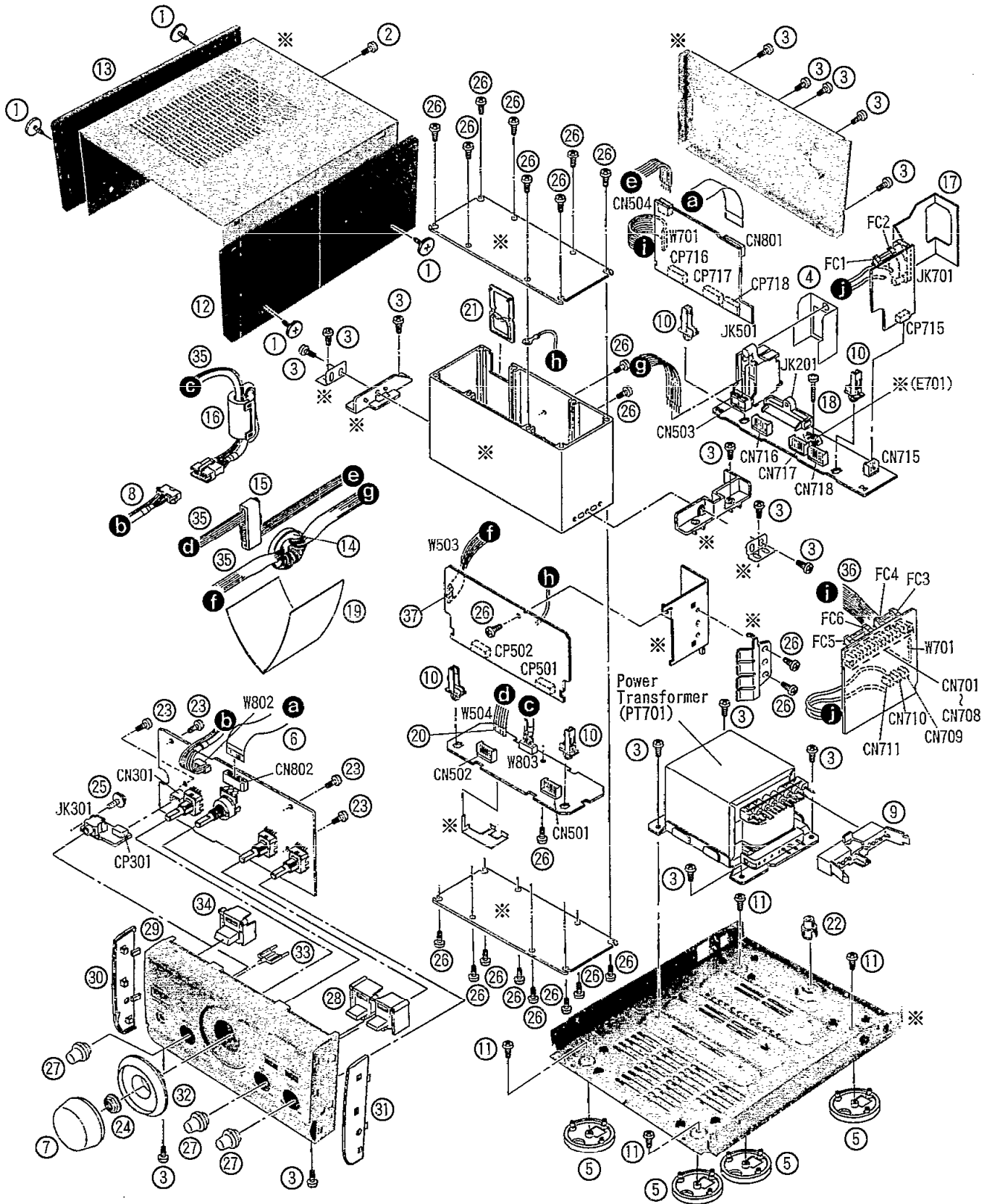

※ : Not supplies.

# ■ Packaging

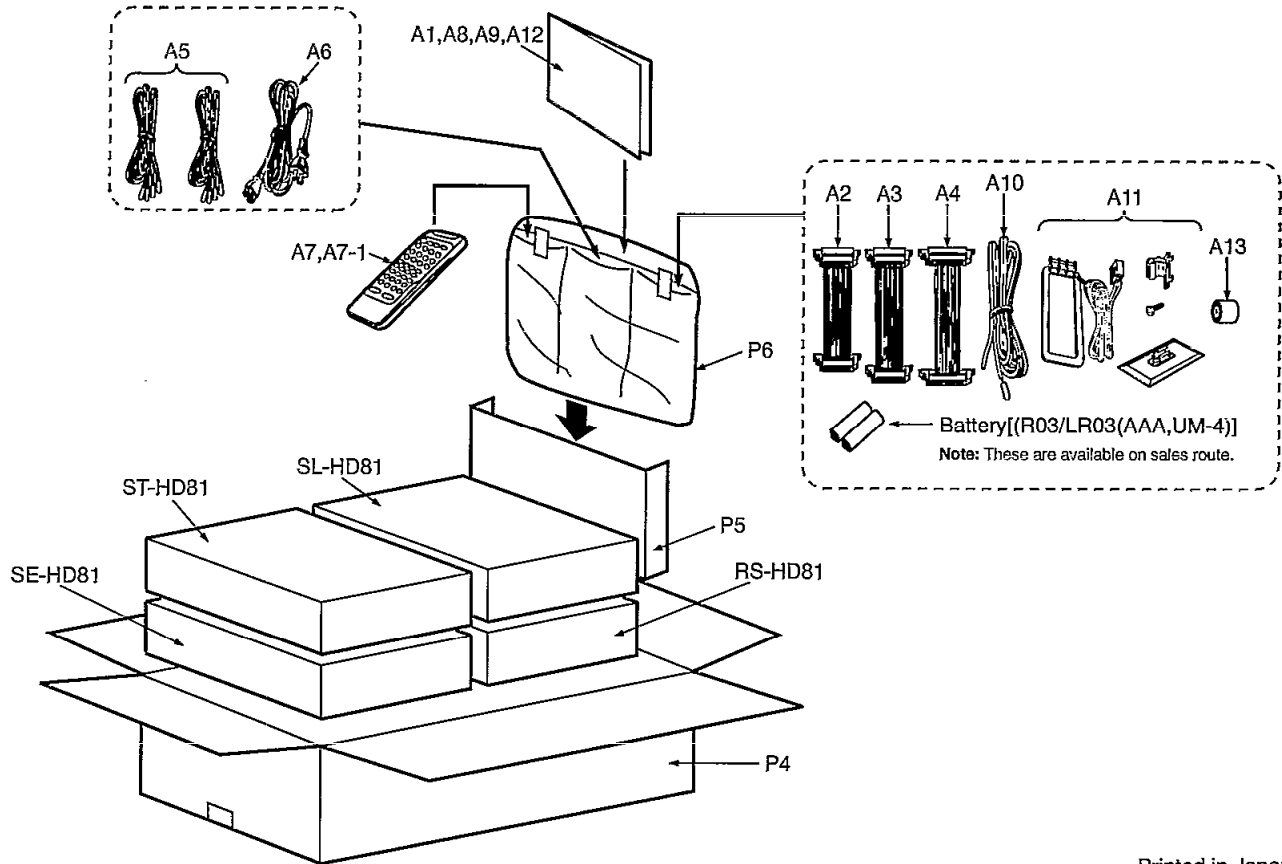
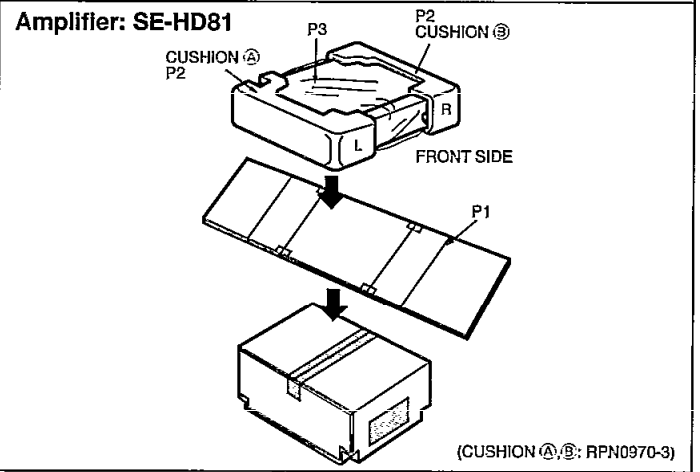
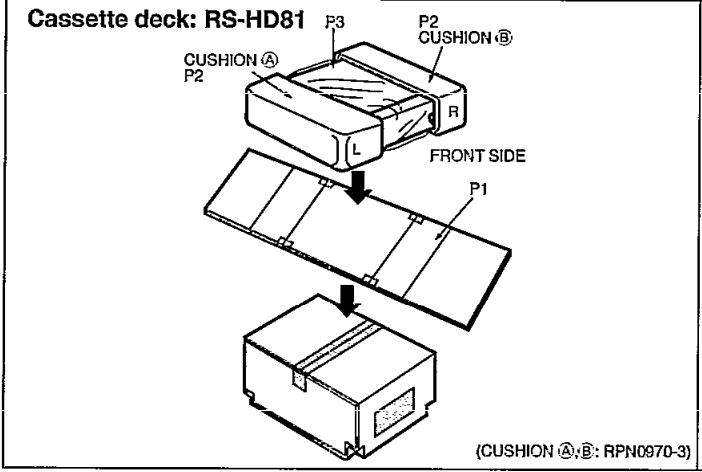
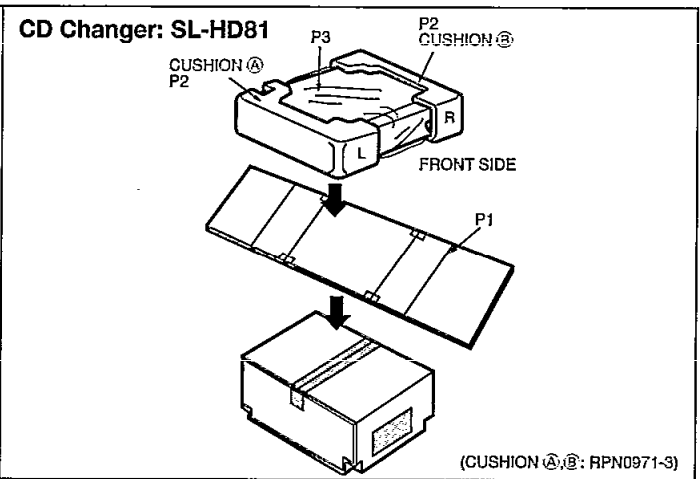
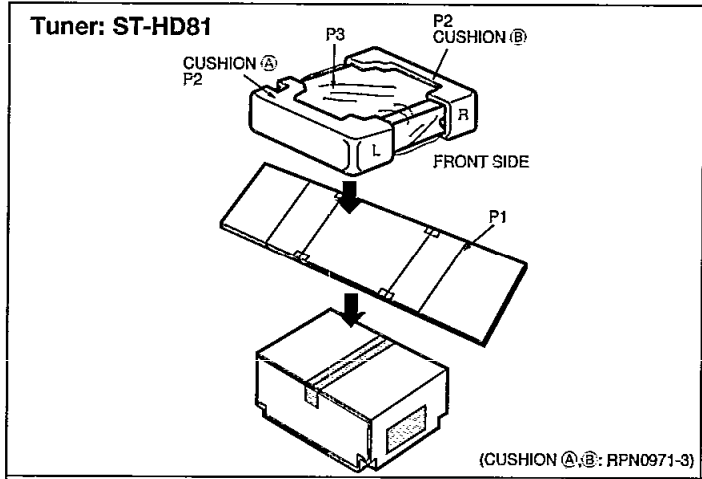

## Replacement Parts List

### Notes: \* - Important safety notice:

Components identified by  $\Delta$  mark have special characteristics important for safety.

Furthermore, special parts which have purposes of fire-retardant (resistors), high-quality sound (capacitors), low-noise (resistors), etc. are used. When replacing any of components, be sure to use only manufacturer's specified parts shown in the parts list.

\* The parenthesized indications in the Remarks columns specify the areas. (Refer to the cover page for area.)

Parts without these indications can be used for all areas.

\* Remote Control Ass'y: Supply period for three years from termination of production.

\* Capacity values are in microfarads ( $\mu$ F) unless specified otherwise,  
P=Pico-farads ( $\mu$ F) F=Farads (F)

\* Resistance values are in ohms, unless specified otherwise, 1K=1,000 (OHM), 1M=1,000k (OHM)

\* "<IA>, <IB>, <IC>, <ID>, <IE>" marks in Remarks indicate language of instruction manual.

<IA>: French/Spanish/Swedish, <IB>: German/Italian/Dutch, <IC>: Danish, <ID>: English, <IE>: Russian/Czeco/Polish]

Ref.No.	Part No.	Part Name & Description	Pcs	Remarks
1	RHD30073-K	SCREW	4	
2	XTBS3+10JFZ1	SCREW	1	
3	XTBS3+8JFZ1	SCREW	17	
4	RSC0457	SHIELD BRACKET	1	
5	RKA0076-N	FOOT	4	
6	REZ0900	FLAT CABLE (CN801, 802/14P)	1	
7	RGW0247A-N	VOLUME KNOB	1	
8	REZ0902	CONNECTOR ASS'Y (5P) (W802)	1	
9	RWN0191	P. C. B. HOLDER	1	
10	RWN0203	P. C. B. HOLDER	4	
11	XTB3+6G	SCREW	4	
12	RGK0809-1M	SIDE PANEL (R)	1	
13	RGK0808-1M	SIDE PANEL (L)	1	
14	RLBT3101-D	FERRITE CORE	1	
15	RLBT4001-D	FERRITE CORE	1	
16	RLB0010	FERRITE CORE	1	
17	RWZ0397	BARRIER	1	
18	XTB3+16JFZ	SCREW	1	
19	RWF0236	SHEET	1	
20	RJS2A1305	CABLE HOLDER (W504)	1	
21	RMR0985-K	EDGE HOLDER	1	
22	SHE185-2	P. C. B. SUPPORT	1	
23	XTBS26+8J	SCREW	4	
24	SNE4021-1	NUT	1	
25	RHD26016	SCREW	1	
26	XTB3+6JFZ	SCREW	22	
27	RGW0198-S	ADJUSTMENT KNOB	3	
28	RGU1393-Q	BUTTON	1	
29	RFKGEHD81E-N	FRONT PANEL ASS'Y	1	
30	RGK0810-N3	SIDE ORNAMENT (L)	1	
31	RGK0811-N3	SIDE ORNAMENT (R)	1	
32	RGK0815-N	VOLUME ORNAMENT	1	
33	RGL0333-2Q	PANEL LIGHT	1	
34	RGU1392-S	BUTTON	1	
35	REZ0901	CONNECTOR ASS'Y	1	
36	REZ0903	FLAT CABLE (8P) (W701)	1	
37	RJS1A5506	CABLE HOLDER (W503)	1	
A1	RQT4304-E	INSTRUCTION MANUAL	1	(E)<IA>

Ref.No.	Part No.	Part Name & Description	Pcs	Remarks
A1	RQT4305-D	INSTRUCTION MANUAL	1	(EG)<IB>
A1	RQT4306-H	INSTRUCTION MANUAL	1	(EG)<IC>
A1	RQT4307-B	INSTRUCTION MANUAL	1	(EB) (EP)<ID>
A1	RQT4308-R	INSTRUCTION MANUAL	1	(EP)<IE>
A2	REX0608	FLAT CABLE (SHORT) (20P)	1	
A3	REX0812	FLAT CABLE (LONG) (19P)	1	
A4	REX0813	FLAT CABLE (MIDDLE) (15P)	1	
A5	RFA0737-R	SPEAKER CORD UNIT	1	
A6	RJA0019-X	AC POWER SUPPLY CORD	1	(E) (EG) (EP)
A6	RJA0053-1X	AC POWER SUPPLY CORD	1	(EB)
A7	RAK-CH214WH	REMOTE CONTROL TRANSMITTER	1	
A7-1	RKK0057-K	BATTERY COVER FOR R. C. T.	1	
A8	RQA0117	WARRANTY CARD	1	(E) (EB) (EG)
A9	RQC80169	SERVICENTER LIST	1	(E) (EB) (EG)
A10	RSA0007	FM INDOOR ANTENNA	1	
A11	RSA0021	AM LOOP ANTENNA	1	
A12	RQCA0600	QUICK SET UP GUIDE	1	(EB)
A13	SJP9009	ANTENNA PLUG ADAPTOR	1	(EB)
C301, 02	ECEA1HKAR22B	50V 0.22U	2	
C303, 04	ECBT1H101KB5	50V 100P	2	
C305, 06	ECBT1H820KB5	50V 82P	2	
C307, 08	RCE1CKA100BG	16V 10U	2	
C309, 10	ECBT1H390J5	50V 39P	2	
C311, 12	ECEA1HKA2R2B	50V 2.2U	2	
C313, 14	ECQV1H823JM3	50V 0.082U	2	
C315, 16	ECQB1H153JF3	50V 0.015U	2	
C317, 18	ECQB1H183JF3	50V 0.018U	2	
C319, 20	ECQB1H222JF3	50V 2200P	2	
C321, 22	ECBT1E232ZF5	25V 0.022U	2	
C323, 24	ECBT1H121KB5	50V 120P	2	
C325, 26	ECQV1H333JM3	50V 0.033U	2	
C327, 28	ECQB1H122JF3	50V 1200P	2	
C330, 31	ECBT1E103ZF5	25V 0.01U	2	
C332	ECEA1HKA010B	50V 1U	1	
C333, 34	RCE1CKA100BG	16V 10U	2	
C335	RCE1AKA101BG	10V 100U	1	
C341-44	ECBT1H101KB5	50V 100P	4	
C345, 46	ECBT1H331KB5	50V 330P	2	
C347, 48	RCE1CKA100BG	16V 10U	2	
C349-52	ECBT1E103ZF5	25V 0.01U	4	
C353	ECBT1H102KB5	50V 1000P	1	
C354, 55	ECBT1C105ZF5	16V 1U	2	
C361, 62	ECBT1H473ZF5	50V 0.047U	2	
C371, 72	ECBT1E103ZF5	25V 0.01U	2	
C381, 82	ECQV1H224JM3	50V 0.22U	2	
C501, 02	RCE1CKA100BG	16V 10U	2	
C503-06	ECUV1H102KBN	50V 1000P	4	
C507	ECUV1E103ZFN	25V 0.01U	1	
C509, 10	ECUV1H331KBN	50V 330P	2	
C511, 12	ECUV1E103ZFN	25V 0.01U	2	
C513, 14	ECUV1E224ZFN	25V 0.22U	2	
C515-18	ECUVNC105ZFN	16V 1U	4	
C519, 20	ECQV1H185JL3	50V 1.8U	2	
C521, 22	ECQV1H824JM3	50V 0.82U	2	
C523, 24	ECBR1H102KB5	50V 1000P	2	
C525	ECUV1H682KBN	50V 6800P	1	
C526	ECUV1H181KCN	50V 180P	1	
C527	ECUVNC225ZFN	16V 2.2U	1	
C529, 30	ECUV1H223ZFN	50V 0.022U	2	
C531, 32	ECUV2H101JCM	500V 100P	2	
C533-36	ECUV1H102KBN	50V 1000P	4	
C543, 44	ECUV1E103ZFN	25V 0.01U	2	
C547	ECUV1H562KBN	50V 5600P	1	
C551	ECEA0JKA101B	6.3V 100U	1	
C552	ECUV1E224ZFN	25V 0.22U	1	
C553, 54	ECUVNC225ZFN	16V 2.2U	2	
C555	ECUV1H102KBN	50V 1000P	1	
C561	ECUV1H472KBN	50V 4700P	1	
C581	ECEA0JKA101B	6.3V 100U	1	
C582	ECUV1E223ZFN	25V 0.022U	1	
C583	ECUVNC105ZFN	16V 1U	1	
C701	ECUV1E104ZFN	25V 0.1U	1	
C702	ECUV1H101KCN	50V 100P	1	
C703, 04	EEUFA1H561E	50V 560U	2	

Ref.No.	Part No.	Part Name & Description	Pcs	Remarks	Ref.No.	Part No.	Part Name & Description	Pcs	Remarks
C705	ECUV1E104ZFN	25V 0.1U	1		△ JK701	SJS9236	JACK, AC INLET	1	
C706	ECUV1H472KBN	50V 4700P	1						
C707,08	ECA1EM101B	25V 100U	2		L301,02	ELEXT101KA9	COIL	2	
C709,10	ECUV1E104ZFN	25V 0.1U	2		L303	RLLS00050T-Y	COIL	1	
C711	ECQE1104KF3	100V 0.1U	1		L501	RLQT560K	COIL	1	
C712	ECKR2H102ZF5	500V 1000P	1		L502	RLQT560K1	COIL	1	
△ C713	ECA1HM470B	50V 47U	1		L503	RLQT560K	COIL	1	
△ C715-18	EEUPL1H102LE	50V 1000U	4		L504	RLQT560K1	COIL	1	
C719	ECEA1EKA470B	25V 47U	1		L505,06	ERD25V0R00T	COIL	2	
C720	ECUV1E104ZFN	25V 0.1U	1		L507,08	BL02RN1R62T2	COIL	2	
C721	ECUV1E103ZFN	25V 0.01U	1		L511	BL02RN2R62T4	COIL	1	
C722	RCE1CKA100BG	16V 10U	1		L513-15	BL02RN2R62T4	COIL	3	
C723	ECEA1CKA101B	16V 100U	1		△ L701	RLQZ271M	COIL	1	
C724,25	ECUV1H102KBN	50V 1000P	2		L702-06	BL02RN2R62T4	COIL	5	
C731	ECEAOJKA101B	6.3V 100U	1		L711	ELEXT101KA9	COIL	1	
C732	ECUVNC105ZFN	16V 1U	1						
C751	ECBT1E223ZF5	25V 0.022U	1		P1	RPG3196	PACKING CASE (AMPLI./DECK)	2	
C752	ECBT1H102KB5	50V 1000P	1		P1	RPG3529	PACKING CASE (CD/TUNER)	2	
C1101,02	ECBT1E223ZF5	25V 0.022U	2		P2	RPNO970-3	CUSHION (AMPLIFIER/DECK)	2	
C1103-06	ECBT1H102KB5	50V 1000P	4		P2	RPNO971-3	CUSHION (CD/TUNER)	2	
C1107,08	ECBT1C105ZF5	16V 1U	2		P3	SPP740	PROTECTION BAG (UNIT)	4	
C1109,10	ECBT1H102KB5	50V 1000P	2		P4	RPG3835	PACKING CASE (SYSTEM)	1	(E)
					P4	RPG3836	PACKING CASE (SYSTEM)	1	(EG)
CN301	RJT057W004-1	CONNECTOR (4P)	1		P4	RPG3958	PACKING CASE (SYSTEM)	1	(EB)
CN501,02	RJT057W007-1	CONNECTOR (7P)	2		P4	RPG3961	PACKING CASE (SYSTEM)	1	(EP)
CN503	RJS1A6606	CONNECTOR (6P)	1		P5	RPQ0771	PAD	1	
CN504	RJS5T7ZA	CONNECTOR (5P)	1		P6	RPF0139	PROTECTION BAG (F.B.)	1	
CN701-11	RJS1A1101T1	CONNECTOR (1P)	11		△ PT701	RTP2M5B011	POWER TRANSFORMER	1	
CN715	RJT057W004-1	CONNECTOR (4P)	1						
CN716-18	RJT057W007-1	CONNECTOR (7P)	3		Q301,02	2SC3312RSTA	TRANSISTOR	2	
CN801,02	RJS1A6714	CONNECTOR (14P)	2		Q303,04	2SD2144STA	TRANSISTOR	2	
					Q305	UN4115TA	TRANSISTOR	1	
CP301	RJU057W004	SOCKET (4P)	1		Q307,08	2SD2144STA	TRANSISTOR	2	
CP501,02	RJU057W007	SOCKET (7P)	2		Q309	UN4115TA	TRANSISTOR	1	
CP715	RJU057W004	SOCKET (4P)	1		Q501-04	2SB792RSTTX	TRANSISTOR	4	
CP716-18	RJU057W007	SOCKET (7P)	3		Q505-08	1RF1510G	TRANSISTOR	4	
					Q551,52	2SB792RSTTX	TRANSISTOR	2	
D505-08	WA111TX	DIODE	4		Q553-56	2SD1819ARTX	TRANSISTOR	4	
D509-14	D1NL20U-4084	DIODE	6		Q557	2SB1218RTW	TRANSISTOR	1	
D551-57	WA111TX	DIODE	7		Q558,59	2SD1819ARTX	TRANSISTOR	2	
D558	MA8033LTX	DIODE	1		Q560	2SB792RSTTX	TRANSISTOR	1	
D559	WA111TX	DIODE	1		Q581,82	2SD1819ARTX	TRANSISTOR	2	
D591-93	WA111TX	DIODE	3		Q583	2SB1218RTW	TRANSISTOR	1	
D594	MA4300MTA	DIODE	1		Q584	2SD1819ARTX	TRANSISTOR	1	
△ D701-04	1N5402BF	DIODE	4		Q591	2SB792RSTTX	TRANSISTOR	1	
△ D705-07	MA4150M	DIODE	3		Q711	2SC3311A1RTA	TRANSISTOR	1	
△ D711,12	RLN4003N02	DIODE	2		△ Q721	2SD2137PQTA	TRANSISTOR	1	
△ D713	MA4051MTA	DIODE	1		Q801-03	UN4111	TRANSISTOR	3	
D714	MA4240MTA	DIODE	1						
△ D721	MA4120HTA	DIODE	1		R301	ERDS2FJ103	1/4W 10K	1	
D722,23	MA185TA	DIODE	2		R302	ERDS2FJ103	1/4W 10K	1	
△ D731	MA4051MTA	DIODE	1		R303,04	ERDS2FJ103	1/4W 10K	2	
D801	LNJ201LPQJA	L. E. D.	1		R305,06	ERDS2FJ224	1/4W 220K	2	
D802,03	LNJ301MPUJAD	L. E. D.	2		R307,08	ERDS2FJ392	1/4W 3.9K	2	
D804	MA16S	DIODE	1		R309,10	ERDS2TJ223T	1/4W 22K	2	
					R311,12	ERDS2TJ102	1/4W 1K	2	
△ F1	XBA2C10TB0	FUSE	1		R313,14	ERDS2FJ392	1/4W 3.9K	2	
△ F701,02	XBA2C16TB0	FUSE	2		R315,16	ERDS2TJ223T	1/4W 22K	2	
					R317,18	ERDS2FJ392	1/4W 3.9K	2	
FC1-C6	EYF52BC	FUSE HOLDER	6		R319,20	ERDS2FJ183	1/4W 18K	2	
					R321,22	ERDS2FJ392	1/4W 3.9K	2	
IC301	M5219FPPTA	IC	1		R323	ERDS2TJ561T	1/4W 560	1	
IC302	TC9215AFEL	IC	1		R325,26	ERDS2TJ152T	1/4W 1.5K	2	
IC303	M5218AFPE3	IC	1		R327,28	ERDS2TJ562	1/4W 5.6K	2	
IC304	M5219FPPTA	IC	1		R329,30	ERDS2TJ104	1/4W 100K	2	
IC501	NJM2114D	IC	1		R332	ERDS2TJ222	1/4W 2.2K	1	
IC502	TC7WU04FT12L	IC	1		R333,34	ERDS2TJ122T	1/4W 1.2K	2	
IC503	TC74HC74AFEL	IC	1		R335,36	ERDS2TJ121T	1/4W 120	2	
IC504	TC74HC00AFT1	IC	1		R337	ERDS2FJ224	1/4W 220K	1	
IC505,06	IR2112	IC	2		R341,42	ERDS2TJ471T	1/4W 470	2	
IC507	TC7W08FTE12L	IC	1		R343,44	ERDS2TJ333T	1/4W 33K	2	
					R345,46	ERDS2TJ122T	1/4W 1.2K	2	
JK201	RJT065K20	JACK, SYSTEM	1		R347,48	ERDS2TJ332T	1/4W 3.3K	2	
JK301	RJJ37TD01-C	JACK, HEADPHONES	1		R349-52	ERDS2FJ470	1/4W 47	4	
JK501	RJR0054	JACK, SPEAKERS	1						

Ref.No.	Part No.	Part Name & Description	Pcs	Remarks	Ref.No.	Part No.	Part Name & Description	Pcs	Remarks
R353, 54	ERDS2TJ121T	1/4W 120	2		VR303	EVJ02QF04G15	V. R	1	
R355	ERDS2TJ334T	1/4W 330K	1		VR801	EVQWQAF2524B	V. R	1	
R356	ERDS2FJ222	1/4W 2.2K	1						
R361	ERDS2TJ273T	1/4W 27K	1		X501	EF0EC2405T4	OSCILLATOR	1	
R371, 72	ERDS2TJ562	1/4W 5.6K	2						
R373, 74	ERDS2TJ332T	1/4W 3.3K	2						
R381, 82	ERDS2FJ392	1/4W 3.9K	2						
R501, 02	ERJ6GEYJ472V	1/10W 4.7K	2						
R503, 04	ERJ6GEYJ824V	1/10W 820K	2						
R505, 06	ERJ6GEYJ103V	1/10W 10K	2						
R507	ERJ6GEYJ301V	1/10W 300	1						
R508	ERJ6GEYJ241V	1/10W 240	1						
R509, 10	ERJ6GEYOR00Z	1/10W 0	2						
R511, 12	ERJ6GEYJ153V	1/10W 15K	2						
R513-16	ERJ6GEYJ562V	1/10W 5.6K	4						
R517-20	ERJ6GEYJ100V	1/10W 1	4						
R523, 24	ERJ6GEYJ473V	1/10W 47K	2						
R525	ERJ6GEYJ273V	1/10W 27K	1						
R526	ERJ6GEYJ153V	1/10W 15K	1						
R541	ERJ6GEYJ105V	1/10W 10	1						
R544	ERJ6GEYJ221V	1/10W 220	1						
R551, 52	ERJ6GEYJ181V	1/10W 180	2						
R553, 54	ERJ6GEYJ392V	1/10W 3.9K	2						
R555, 56	ERF2EXKR22V	2W 0.22	2						
R557, 58	ERJ6GEYJ103V	1/10W 10K	2						
R559	ERJ6GEYJ153V	1/10W 15K	1						
R561	ERJ6GEYJ152V	1/10W 1.5K	1						
R562	ERJ6GEYJ153V	1/10W 15K	1						
R563	ERJ6GEYJ473V	1/10W 47K	1						
R564, 65	ERJ6GEYJ103V	1/10W 10K	2						
R566	ERJ6GEYJ222V	1/10W 2.2K	1						
R567, 68	ERJ6GEYJ153V	1/10W 15K	2						
R569	ERJ6GEYJ473V	1/10W 47K	1						
R570	ERJ6GEYJ103V	1/10W 10K	1						
R571	ERJ6GEYJ102Z	1/10W 1K	1						
R572	ERJ6GEYJ103V	1/10W 10K	1						
R573	ERJ6GEYJ472V	1/10W 4.7K	1						
R574	ERJ6GEYJ103V	1/10W 10K	1						
R575	ERJ6GEYJ105V	1/10W 10	1						
R581	ERJ6GEYJ124V	1/10W 120K	1						
R582	ERJ6GEYJ823V	1/10W 82K	1						
R583	ERJ6GEYJ563V	1/10W 56K	1						
R584	ERJ6GEYJ564V	1/10W 560K	1						
R585	ERJ6GEYJ223V	1/10W 22K	1						
R586	ERJ6GEYJ103V	1/10W 10K	1						
R587	ERDS2TJ473T	1/4W 47K	1						
R591, 92	ERJ6GEYJ102Z	1/10W 1K	2						
R593	ERJ6GEYJ473V	1/10W 47K	1						
R594	ERJ6GEYJ223V	1/10W 22K	1						
△ R701, 02	ERDS1FJ182	1/2W 1.8K	2						
△ R703	ERDS1FJ392	1/2W 3.9K	1						
△ R704	ERQ16NKKW1ROE	1/6W 1	1						
R711	ERG1SJ221	1W 220	1						
R712	ERG1SJ271	1W 270	1						
R713	ERDS2TJ333T	1/4W 33K	1						
R714	ERDS2FJ392	1/4W 3.9K	1						
R715	ERDS2TJ473T	1/4W 47K	1						
R721	ERG2SJ331	2W 330	1						
R722	ERDS2FJ222	1/4W 2.2K	1						
R731, 32	ERDS2TJ221T	1/4W 220	2						
R741, 42	ERDS2FJ102	1/4W 1K	2						
R751-53	ERDS2FJ101	1/4W 100	3						
R801	ERDS2TJ821T	1/4W 820	1						
R802	ERDS2FJ102	1/4W 1K	1						
R803	ERDS2TJ271T	1/4W 270	1						
R805	ERDS2FJ472	1/4W 4.7K	1						
R807	ERDS2TJ331T	1/4W 330	1						
R808	ERDS2FJ104	1/4W 100K	1						
R810	ERDS2TJ331T	1/4W 330	1						
△ RL701	RSY0013M-0	RELAY	1						
S801-03	EVQPTD05Q	SW	3						
VR301, 02	EVJYA1F04C15	V. R	2						

### Cabinet Parts Location

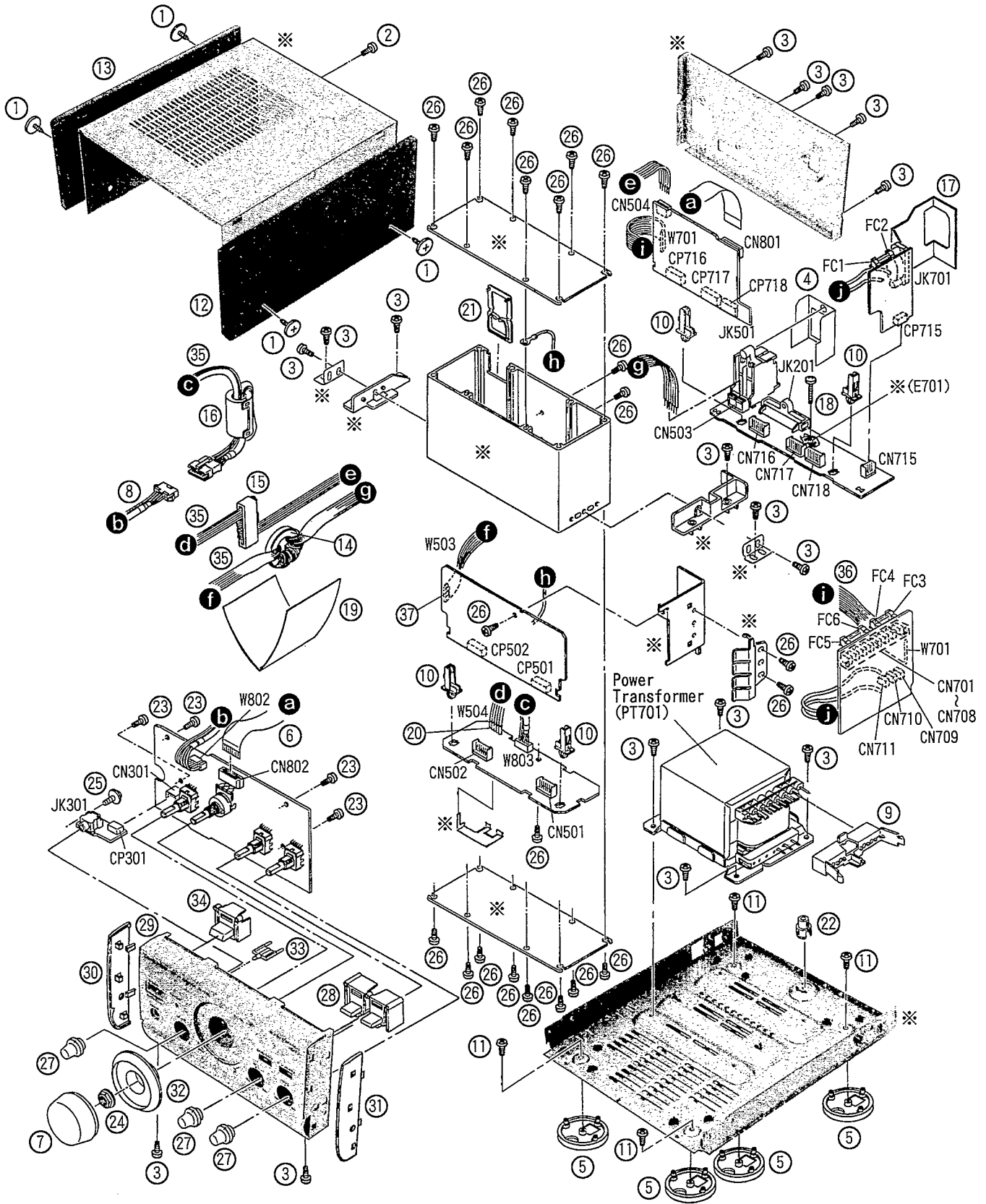

※ : Not supplies.

# ■ Packaging

