

Service Manual

Amplifier

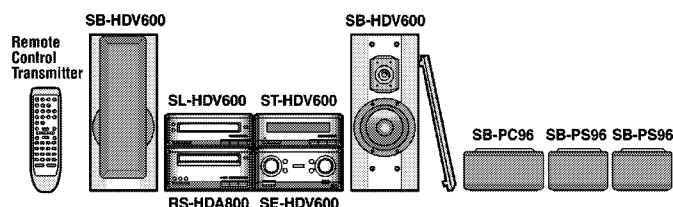

SE-HDV600

Colour

(N).....Gold Type

Areas

(E).....Europe and East Europe.

(EB).....Great Britain.

(EG).....Germany, Italy and France.

Because of unique interconnecting cables, when a component requires service, send or bring in the entire system.

System	SC-HDV600
Tuner	ST-HDV600
Amplifier	SE-HDV600
DVD Player	SL-HDV600
Cassette Deck	RS-HDA800
Front Speakers*	SB-HDV600

Except for Great Britain

Center Speaker*	SB-PC96
Surround Speakers*	SB-PS96

*: Made in Spain.

Specifications

Amplifier section (Stereo mode)

[Low frequency]

Power output:

RMS 1 kHz, THD 10 %, both channels driven; 2×17 W (6 Ω)

[High frequency]

Power output:

RMS 10 kHz, THD 10 %, both channels driven; 2×8 W (6 Ω)

Amplifier section (Multichannel mode)

[Low frequency]

Power output:

DIN 1 kHz, THD 1 %, both channels driven; 2×8 W (6 Ω)

RMS 1 kHz, THD 10 %, both channels driven; 2×10 W (6 Ω)

Total harmonic distortion:

Half power at 1 kHz; 0.07 % (6 Ω)

Load impedance: 6 Ω

[High frequency]

Power output:

DIN 10 kHz, THD 1 %, both channels driven; 2×6 W (6 Ω)

RMS 10 kHz, THD 10 %, both channels driven; 2×8 W (6 Ω)

Load impedance: 6 Ω

[Surround, Center]

Power output:

DIN 1 kHz, THD 1 %, both channels driven; 3×6 W (8 Ω)

RMS 1 kHz, THD 10 %, both channels driven; 3×8 W (8 Ω)

Load impedance: 8 Ω

S/N:

78 dB

Rated power, 2 V input, VGCA ON;

98 dB

Headphones

Jack type:

3.5 mm STEREO

Load impedance:

16 – 32 Ω

General

Power supply:

(E), (EG) areas;

AC 230 V, 50 Hz

(EB) area;

AC 230 – 240 V, 50 Hz

Power consumption:

110 W

STANDBY condition:

0.9 W

Dimensions (W×H×D):

210×104.8×300 mm

Mass:

3.5 kg

Notes: Specifications are subject to change without notice.

Mass and dimensions are approximate.

Total harmonic distortion is measured by the digital spectrum analyzer.

Technics®

© 2001 Matsushita Electric Industrial Co., Ltd. All rights reserved. Unauthorized copying and distribution is a violation of law.

⚠ WARNING

This service information is designed for experienced repair technicians only and is not designed for use by the general public. It does not contain warnings or cautions to advise non-technical individuals of potential dangers in attempting to service a product. Products powered by electricity should be serviced or repaired only by experienced professional technicians. Any attempt to service or repair the product or products dealt with in this service information by anyone else could result in serious injury or death.

CONTENTS

	Page		Page
1 Before Repair	2	7 To Supply Power Source and Signal Check	9
2 Protection Circuitry	2	8 Type Illustration of ICs, Transistors and Diodes	10
3 Accessories	3	9 Schematic Diagram Notes	10
4 Caution for AC Mains Lead	4	10 Schematic Diagram	11
5 Location of Controls	5	11 Printed Circuit Board Diagram	17
6 Operation Checks and Component Replacement Procedures	6	12 Wiring Connection Diagram	22
6.1. Checking for the power supply P.C.B.	6	13 Block Diagram	23
6.2. Checking for the operation P.C.B.	6	14 Replacement Parts List	25
6.3. Checking for the main P.C.B.	7	15 Cabinet Parts Location	29
6.4. Replacement for the fan motor	7	16 Packaging	30
6.5. Replacement for the power IC	8		

1 Before Repair

1. Turn off the power supply. Using a 10 Ω , 10 W resistor, connect both ends of power supply capacitors (C601, C602) in order to discharge the voltage.
2. Before turning the power supply on, after completion of repair, slowly apply the primary voltage by using a power supply voltage controller to make sure that the consumed current at 50 Hz in NO SIGNAL mode should be shown below with respect to supply voltage 230/240 V.

Power supply voltage	AC 230 V	AC 240 V	
Consumed current 50 Hz	80 - 330 mA		

2 Protection Circuitry

The protection circuitry may have operated if either of the following conditions is noticed:

- No sound is heard when the power is supplied.
- Sound stops during a performance.

The functions of this circuitry is to prevent circuitry damage if, for example, the positive and negative speaker connection wires are shorted, or if speaker systems with an impedance less than the indicated rated impedance of this unit are used.

If this occurs, follow the procedure outlined bellow:

1. Press the Standby/on button, switch to standby mode.
2. Determine the cause of the problem and correct it.
3. Press the Standby/on button once again, supply the power.

Note:

When the protection circuitry functions, the unit will not operate unless the Standby/on button is first switched Standby and then ON again.

3 Accessories

- AC power supply cord for (E), (EG) areas
(RJA0019-1X).....1 pc.

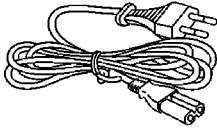

- AC power supply cord for (EB) area
(RJA0053-2X).....1 pc.

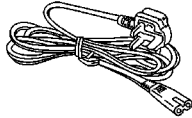

- AM loop antenna set
(RSA0035).....1 pc.

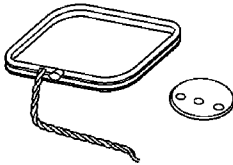

- FM indoor antenna
(RSA0007).....1 pc.

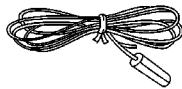

- Surround cable
(REX0941).....1 pc.



- Video connection cable
(RJL1P019B15).....1 pc.



- Speaker cords
(REE1057) (Red, Black).....2 pcs.
(REE0853) (Blue, Gray).....2 pcs.



- Remote control transmitter
(EUR7702080).....1 pc.

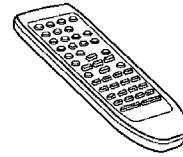

- Remote control batteries
(R6/LR6, AA, UM-3).....2 pcs.

Note: These are available on sales route.

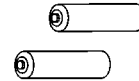

- Antenna plug adaptor for (EB) area
(SJP9009).....1 pc.

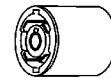

- SKART plug adaptor
(VFA0151-2).....1 pc.

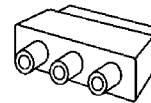

4 Caution for AC Mains Lead

(For United Kingdom)

("EB" area code model only)

For your safety, please read the following text carefully.

This appliance is supplied with a moulded three pin mains plug for your safety and convenience.

A 5-ampere fuse is fitted in this plug.

Should the fuse need to be replaced please ensure that the replacement fuse has a rating of 5-ampere and that it is approved by ASTA or BSI to BS1362.

Check for the ASTA mark  or the BSI mark  on the body of the fuse.

If the plug contains a removable fuse cover you must ensure that it is refitted when the fuse is replaced.

If you lose the fuse cover the plug must not be used until a replacement cover is obtained.

A replacement fuse cover can be purchased from your local dealer.

CAUTION!

IF THE FITTED MOULDED PLUG IS UNSUITABLE FOR THE SOCKET OUTLET IN YOUR HOME THEN THE FUSE SHOULD BE REMOVED AND THE PLUG CUT OFF AND DISPOSED OF SAFELY.

THERE IS A DANGER OF SEVERE ELECTRICAL SHOCK IF THE CUT OFF PLUG IS INSERTED INTO ANY 13-AMPERE SOCKET.

If a new plug is to be fitted please observe the wiring code as shown below.

If in any doubt please consult a qualified electrician.

IMPORTANT

The wires in this mains lead are coloured in accordance with the following code:

Blue: Neutral, Brown: Live.

As these colours may not correspond with the coloured markings identifying the terminals in your plug, proceed as follows:

The wire which is coloured Blue must be connected to the terminal which is coloured Blue or marked with the letter N or coloured Black or Blue.

The wire which is coloured Brown must be connected to the terminal which is marked with the letter L or coloured Brown or Red.

WARNING: DO NOT CONNECT EITHER WIRE TO THE EARTH TERMINAL WHICH IS MARKED WITH THE LETTER E, BY THE EARTH SYMBOL  OR COLOURED GREEN OR GREEN/YELLOW.

THIS PLUG IS NOT WATERPROOF—KEEP DRY.

Before use

Remove the connector cover.

How to replace the fuse

The location of the fuse differ according to the type of AC mains plug (figures A and B). Confirm the AC mains plug fitted and follow the instructions below.

Illustrations may differ from actual AC mains plug.

1. Open the fuse cover with a screwdriver.

Figure A

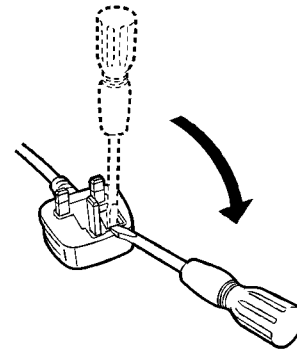
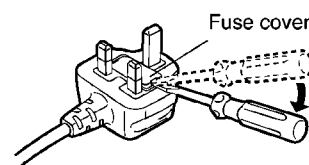

Figure B



2. Replace the fuse and close or attach the fuse cover.

Figure A

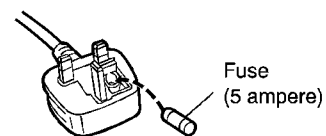
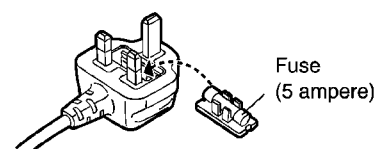
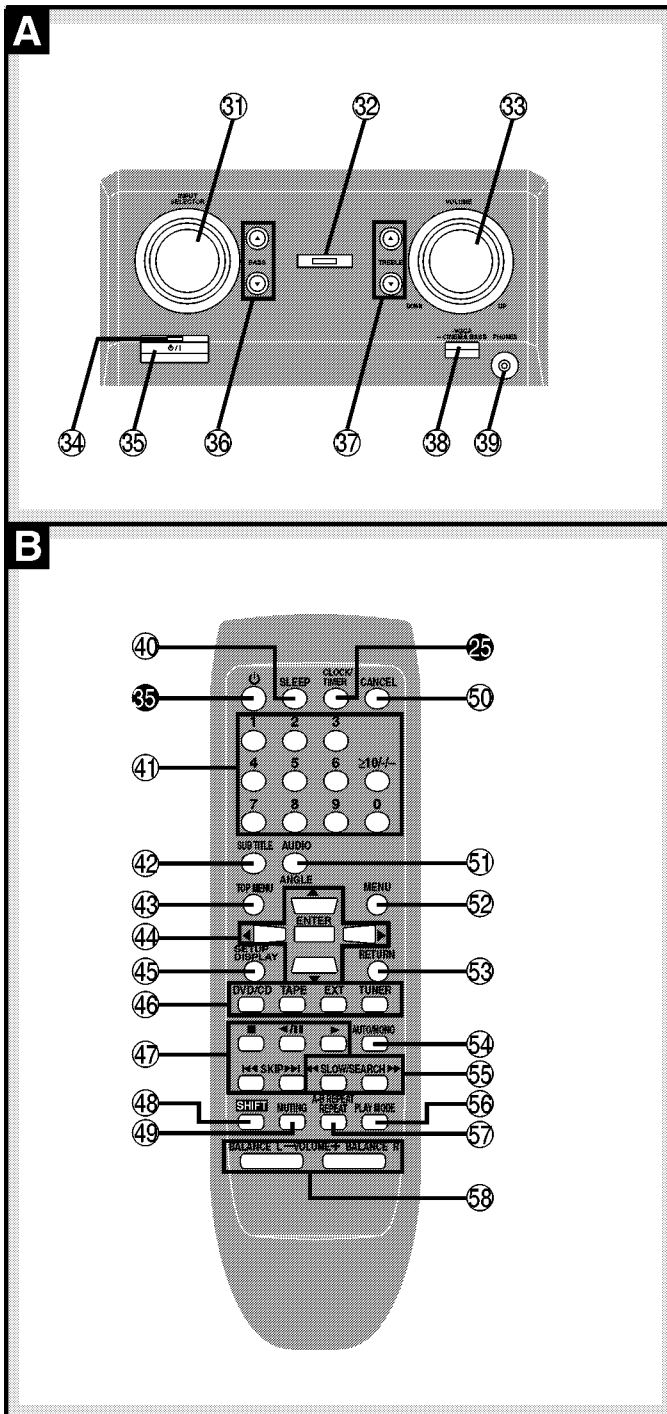

Figure B



5 Location of Controls



A Amplifier

- ① Input selector (INPUT SELECTOR)
- ② VGCA indicator (VGCA)
- ③ Volume control (VOLUME)
- ④ Standby indicator

When the unit is connected to the AC mains supply, this indicator lights up in standby mode and goes out when the unit is turned on.
- ⑤ Standby/on switch (⏻ / I)

Press to switch the unit from on to standby mode or vice versa. In standby mode, the unit is still consuming a small amount of power.
- ⑥ Bass selector (BASS ▲, ▼)
- ⑦ Treble selector (TREBLE ▲, ▼)
- ⑧ VGCA/Cinema bass button (-VGCA, -CINEMA BASS)
- ⑨ Headphone jack (PHONES)

B Remote control

Buttons ④ and ⑤ function the same as the controls on the main unit.

- ④ Sleep timer button (SLEEP)
- ① Numbered buttons
- ② Subtitle button (SUBTITLE)
- ③ Top menu button (TOP MENU)
- ④ Cursor/Enter buttons (◀ ▶ ▲ ▼ ENTER)
- ⑤ Display/Setup button (DISPLAY, SETUP)
- ⑥ Input select buttons (DVD/CD, TAPE, EXT, TUNER)
- ⑦ Basic operating buttons

Function changes according to the source.
- ⑧ Shift button (SHIFT)
- ⑨ Muting button (MUTING)
- ⑩ Cancel button (CANCEL)
- ⑪ Audio/Angle button (AUDIO, ANGLE)
- ⑫ Menu button (MENU)
- ⑬ Return button (RETURN)
- ⑭ FM mode select button (AUTO/MONO)
- ⑮ Slow/Search buttons (◀◀ SLOW/SEARCH ▶▶)
- ⑯ Play mode select button (PLAY MODE)
- ⑰ Repeat/A-B repeat button (REPEAT, A-B REPEAT)
- ⑱ Volume/Balance buttons (VOLUME +, BALANCE L, BALANCE R)

6 Operation Checks and Component Replacement Procedures

- This section describes procedures for checking the operation of the major printed circuit boards and replacing the main components.
- For reassembly after operation checks or replacement, reverse the respective procedures. Special reassembly procedures are described only when required.

6.1. Checking for the power supply P.C.B.

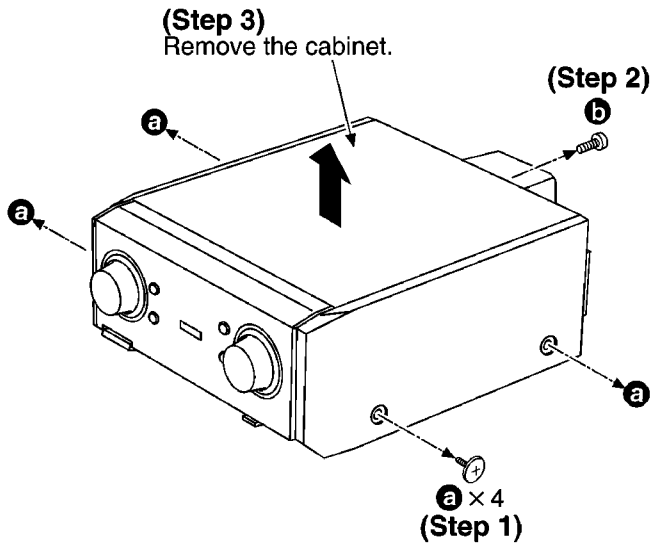

- Check the power supply P.C.B. as shown below.

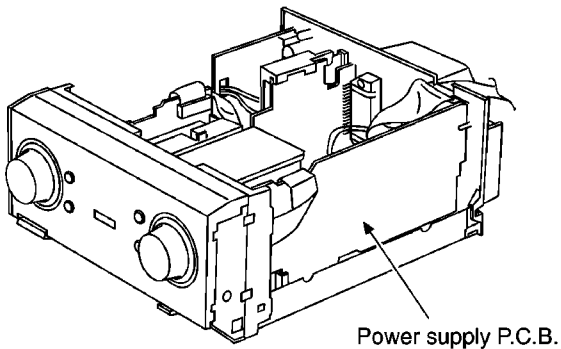

6.2. Checking for the operation P.C.B.

- Follow the (Step 1) - (Step 3) of item 6.1.

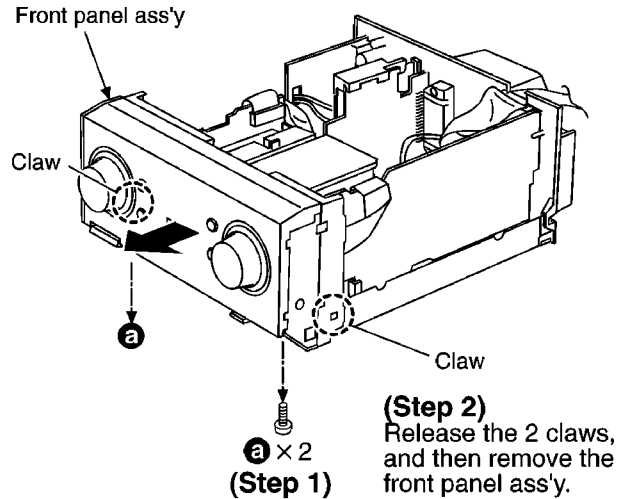

- Check the operation P.C.B. as shown below.

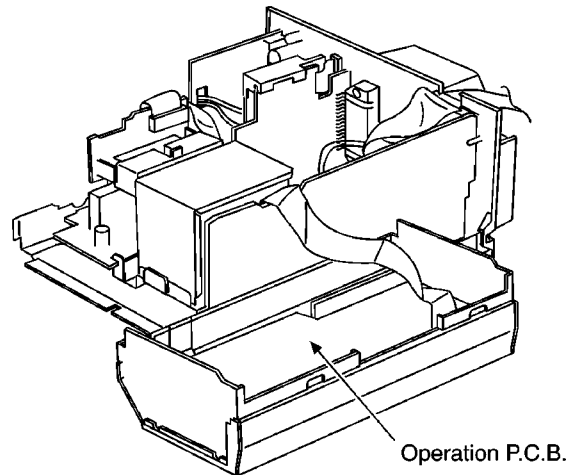

6.3. Checking for the main P.C.B.

- Follow the (Step 1) - (Step 3) of item 6.1.

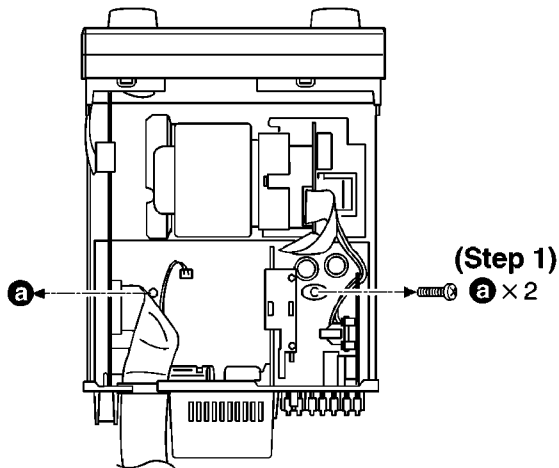

- Check the main P.C.B. as shown below.

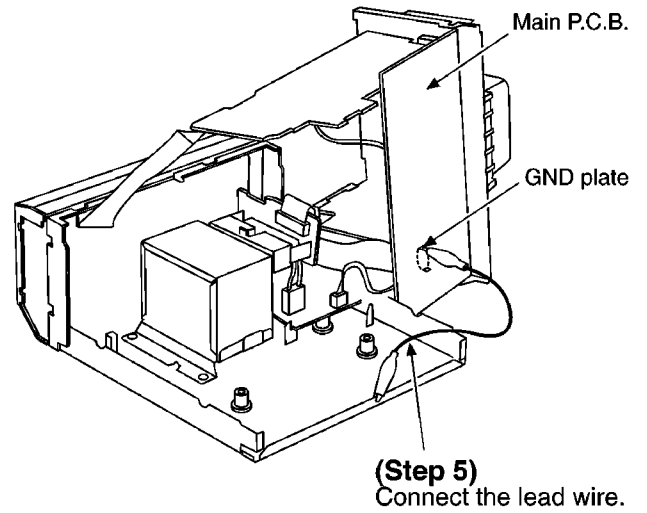

- (Step 3)
Release the 2 claws, and then lift up the rear panel.

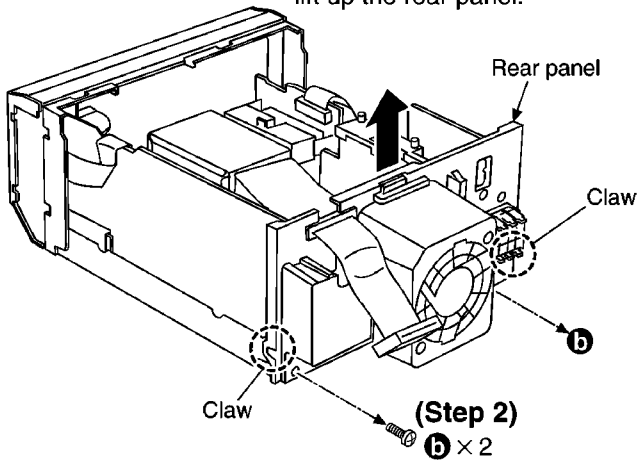

6.4. Replacement for the fan motor

- Follow the (Step 1) - (Step 3) of item 6.1.

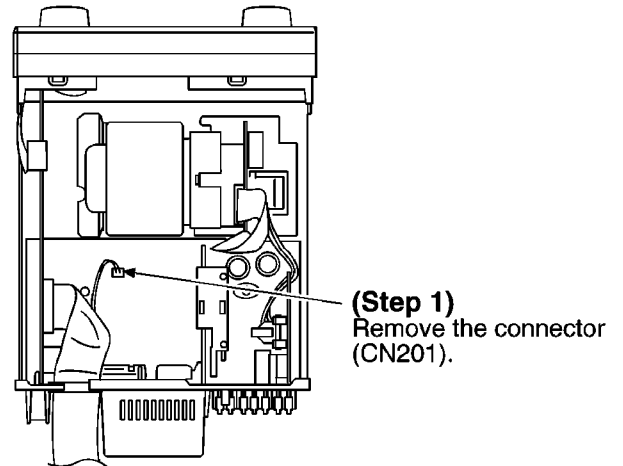

- (Step 4)
Remove the rear panel, power supply P.C.B. and main P.C.B. in the direction of arrow.

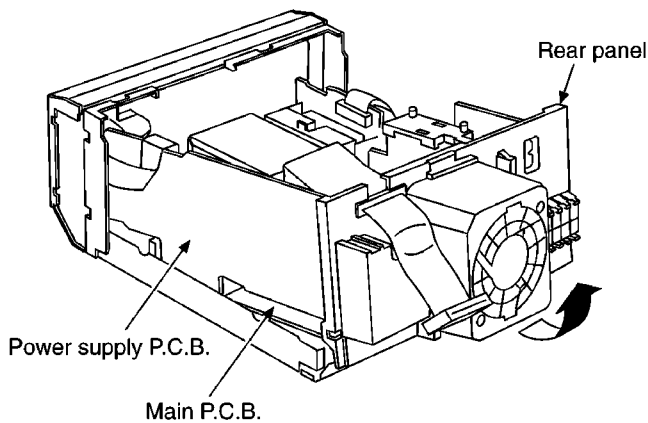

- (Step 3)
Release the 2 claws.

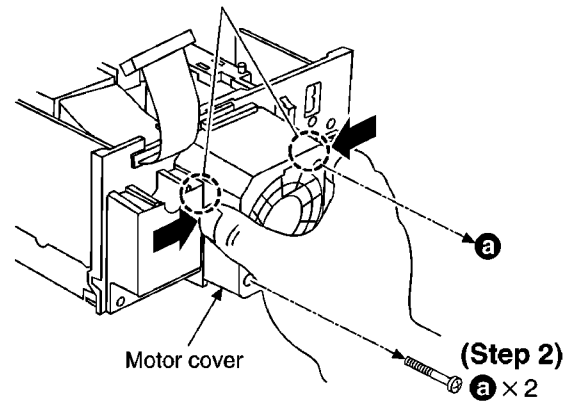

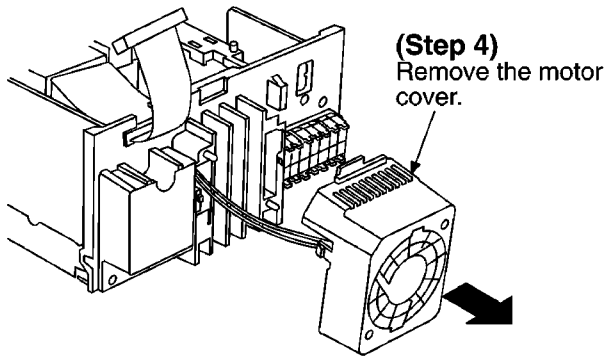

(Step 5)
Release the 2 claws, and then remove the fan motor.

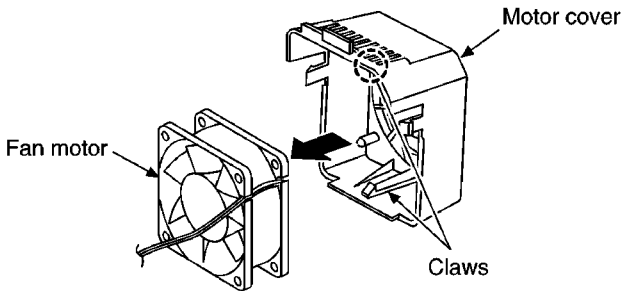

6.5. Replacement for the power IC

- Follow the **(Step 1)** - **(Step 3)** of item 6.1.
- Follow the **(Step 1)** - **(Step 4)** of item 6.3.

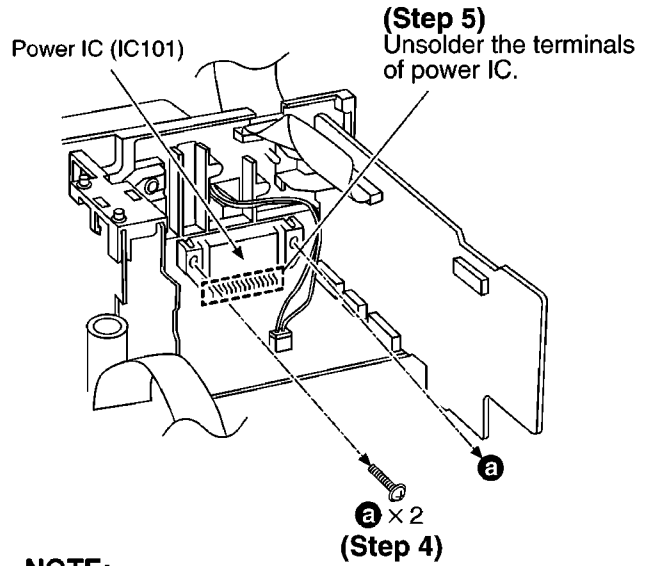

NOTE:
When mounting the power IC apply silicone compound (RFKX0002) to the rear side of power IC.

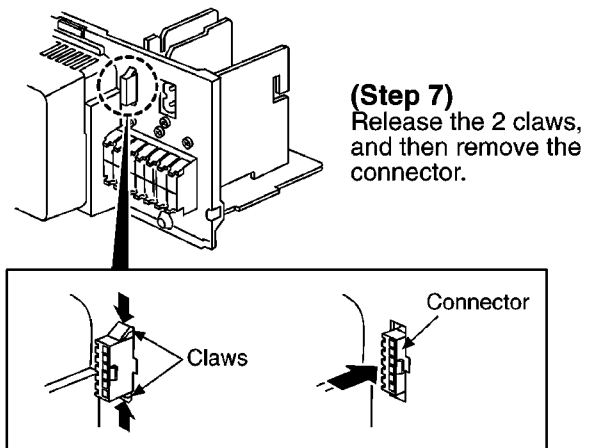
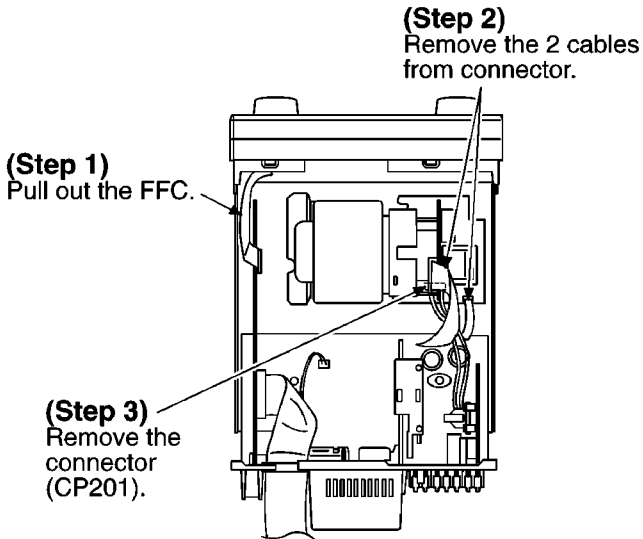
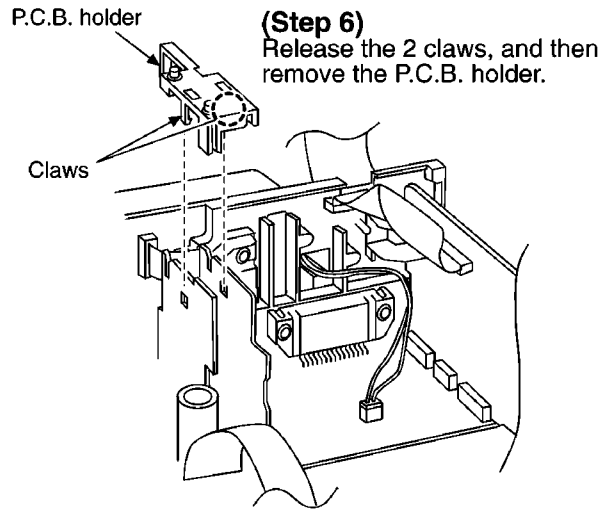

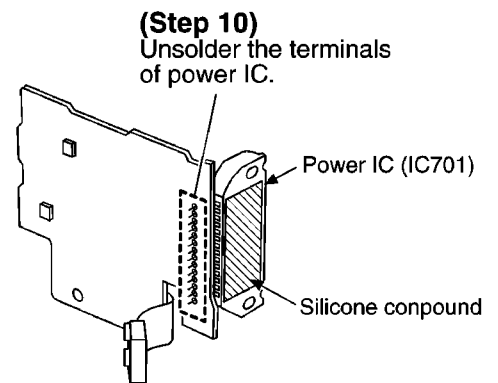
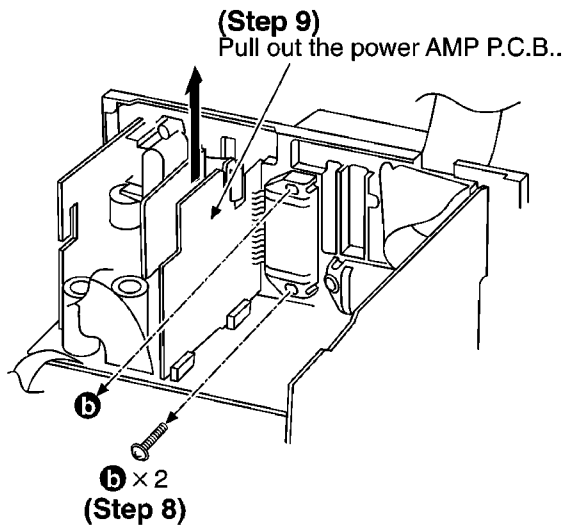

NOTE:
When mounting the power IC apply silicone compound (RFKX0002) to the rear side of power IC.

7 To Supply Power Source and Signal Check

To operate this unit SE-HDV600 normally, it is necessary to connect to the unit ST-HDV600. When operating the unit SE-HDV600, be sure to connect to the unit ST-HDV600 by connection cable.

1. Connect with the Tuner (ST-HDV600). Refer to Fig. 7-1.
2. Connect the AC power supply cord to the Amplifier (SE-HDV600). Refer to Fig. 7-1.
3. Connect the speakers to speaker terminal.

Refer to Fig. 7-1.

4. Turn on the power of the Amplifier (SE-HDV600).
5. Set INPUT SELECTER to select the external source (EXT) of the Amplifier (SE-HDV600).
6. Input a sound signal to external input terminal of the Tuner (ST-HDV600), and confirm to be outputted from the speaker.

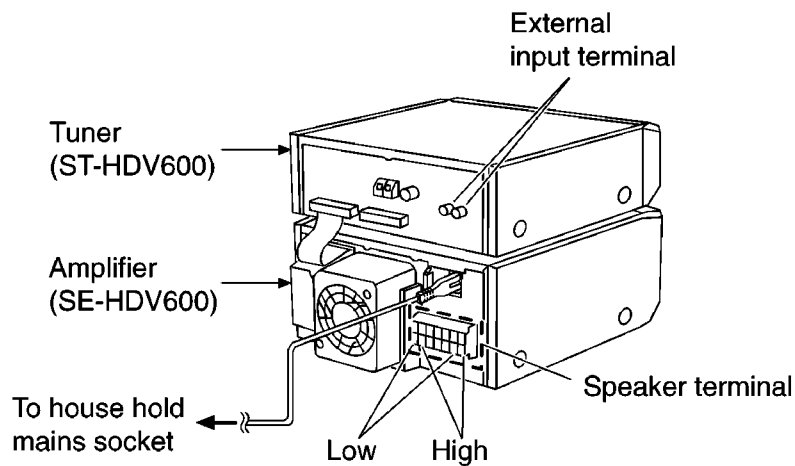
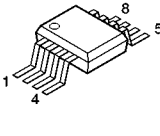
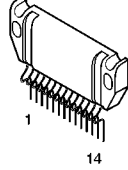
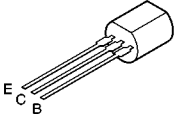
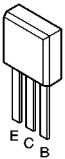
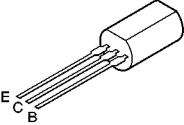
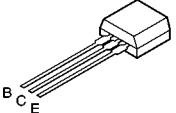
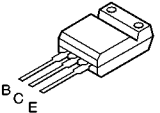
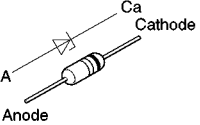
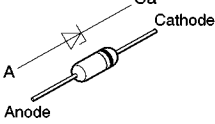
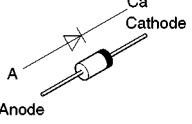
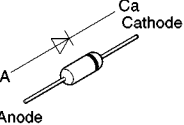
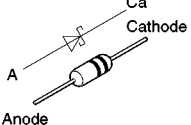
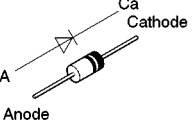
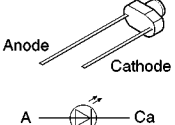

Fig. 7-1.







8 Type Illustration of ICs, Transistors and Diodes

M5218AFPE3 	RSN314H41 	2SB621AQRSTA 2SD592AQRSTA 	 2SA1309ATA 2SC3311ATA UN4111TA UN4115TA UN4211TA	2SC3940AQSTA 
2SD2144STA 	2SB1417PQTA 2SD2137PQTA 	MA4051MTA MA4068MTA MA4091MTA 	 MA4075MTA MA4120MTA MA4150MTA MA4160MTA MA4240MTA	1N5402BM21 RL1N4003N02 
MA165TA 	MA719TA 	SB360L6508 	SLR-325MC SLR-325VC 	

9 Schematic Diagram Notes

- This schematic diagram may be modified at any time with the development of new technology.

Notes:

S501:	Power standby/on switch ( /I)
S503:	Bass down switch (BASS )
S504:	Bass up switch (BASS )
S505:	VGCA /Cinema bass switch ( VGCA  CINEMA BASS)
S506:	Treble down switch (TREBLE )
S507:	Treble up switch (TREBLE )
VR501:	Input selector VR (INPUT SELECTOR)
VR502:	Volume control VR (VOLUME)

- Indicated voltage values are the standard values for the unit measured by the DC electronic circuit tester (high-impedance) with the chassis taken as standard. Therefore, there may exist some errors in the voltage values, depending on the internal impedance of the DC circuit tester.

No mark : Power ON

- Important safety notice:

Components identified by  mark have special characteristics important for safety.

Furthermore, special parts which have purposes of fire-retardant (resistors), high-quality sound (capacitors), low-noise (resistors), etc. are used.

When replacing any of components, be sure to use only manufacturer's specified parts shown in the parts list.

- The supply part number is described alone in the replacement parts list.

• Caution!

IC and LSI are sensitive to static electricity.

Secondary trouble can be prevented by taking care during repair.

Cover the parts boxes made of plastics with aluminum foil.

Ground the soldering iron.

Put a conductive mat on the work table.

Do not touch the legs of IC or LSI with the fingers directly.

- Voltage and signal line

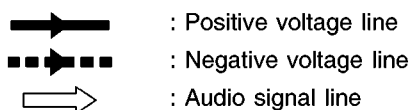

10 Schematic Diagram

SCHEMATIC DIAGRAM-1

A POWER SUPPLY CIRCUIT

→ : POSITIVE VOLTAGE LINE
 - - - - - : NEGATIVE VOLTAGE LINE ⇨ : AUDIO SIGNAL LINE

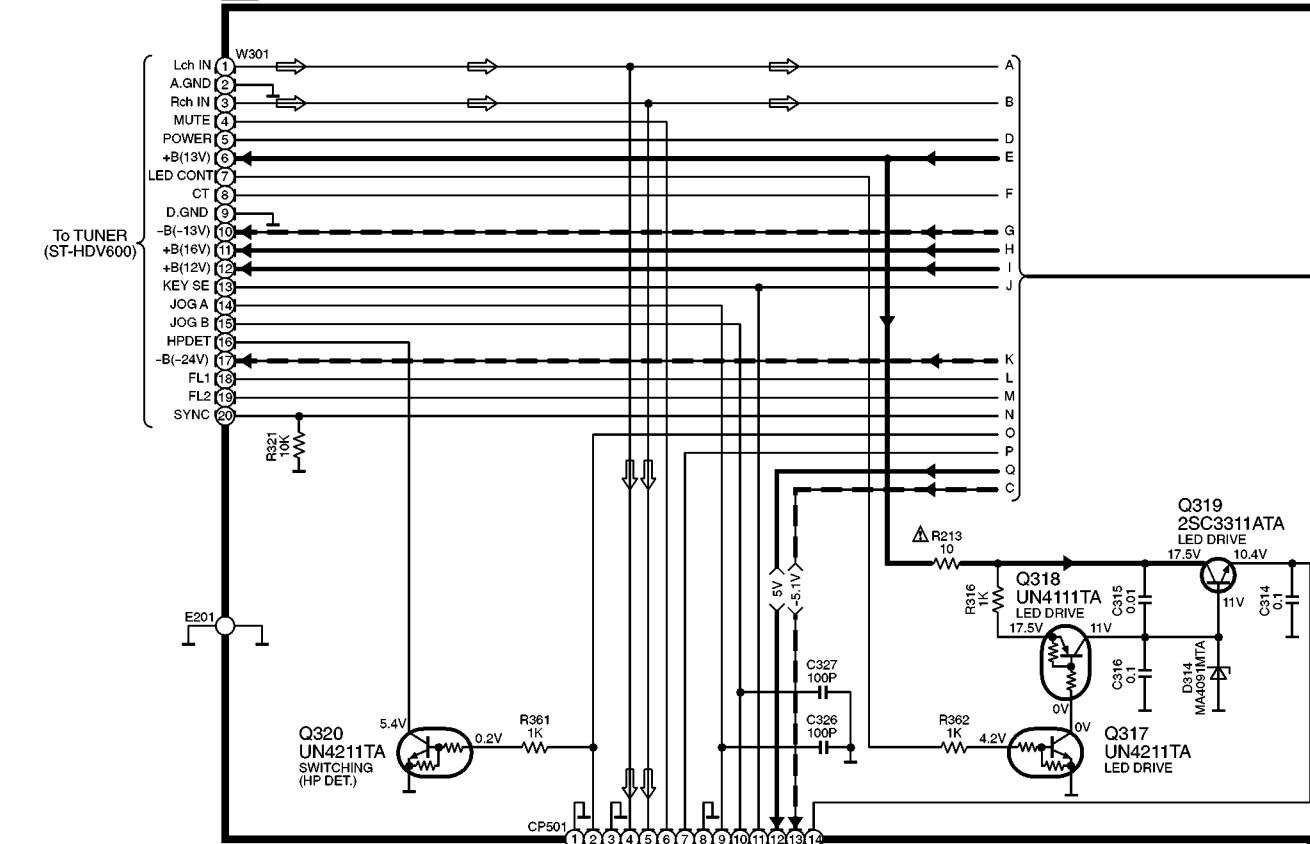

B OPERATION CIRCUIT

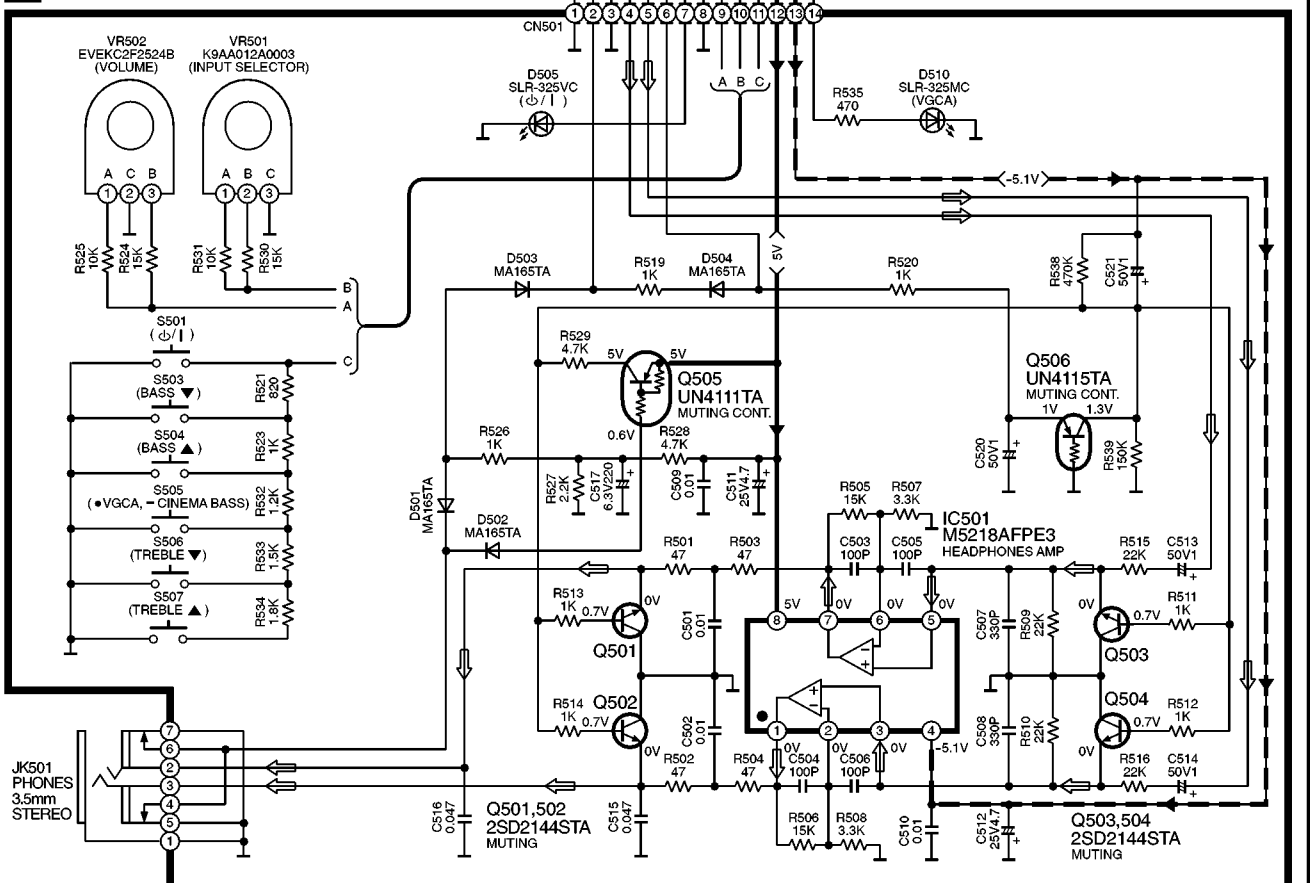

SCHEMATIC DIAGRAM-2

→ : POSITIVE VOLTAGE LINE → - : NEGATIVE VOLTAGE LINE ⇨ : AUDIO SIGNAL LINE

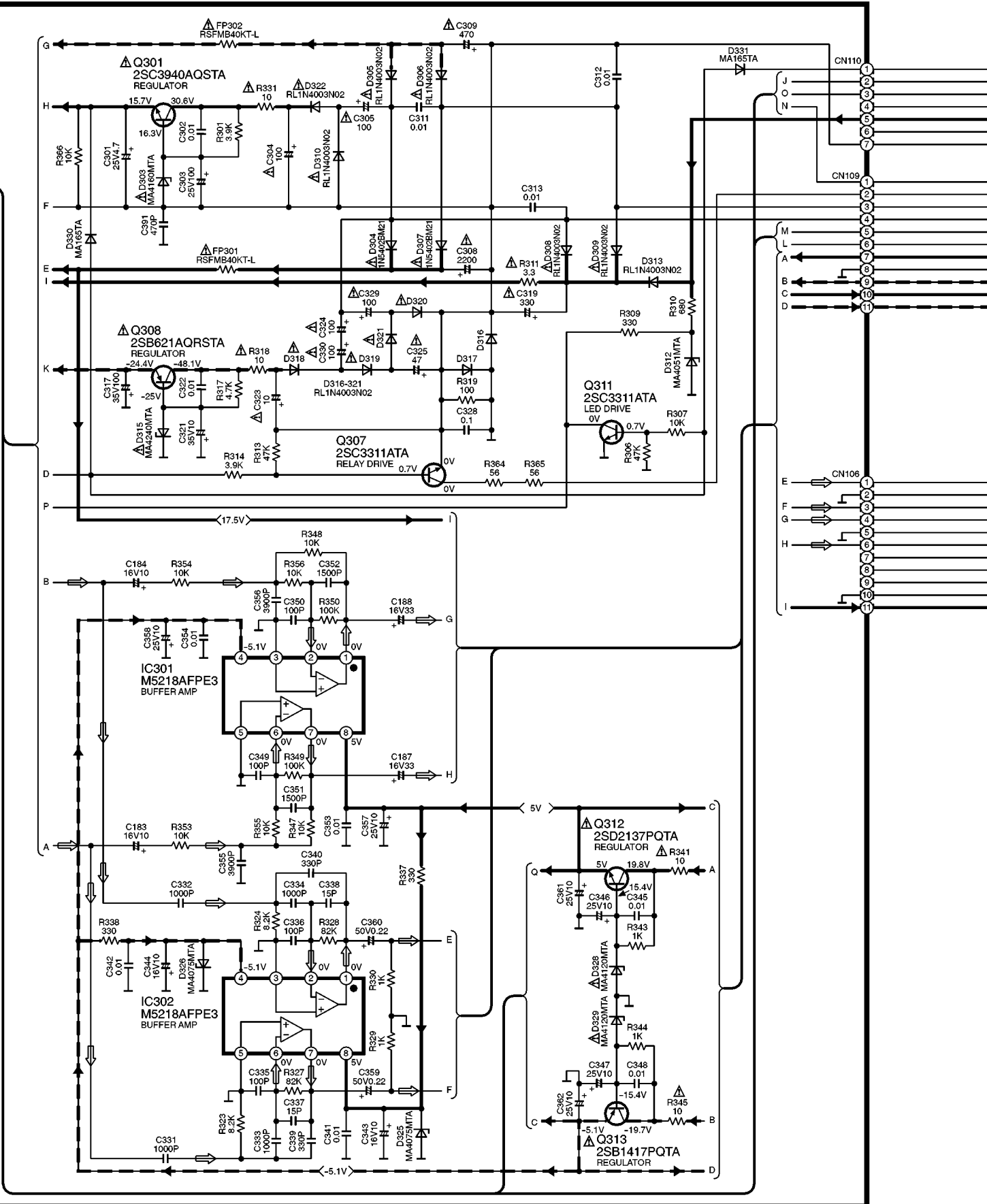

SCHMATIC DIAGRAM-3

C MAIN CIRCUIT

→ : POSITIVE VOLTAGE LINE
 - - - - - : NEGATIVE VOLTAGE LINE ⇨ : AUDIO SIGNAL LINE

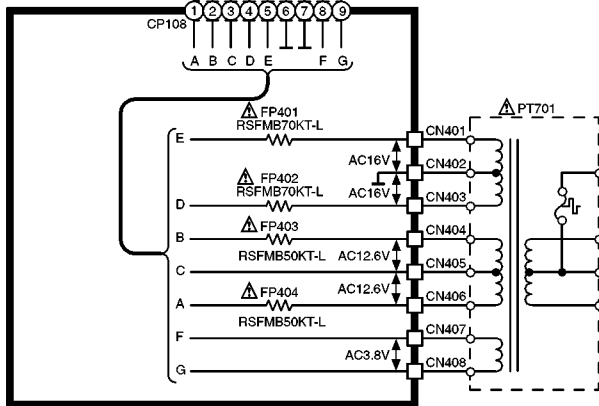
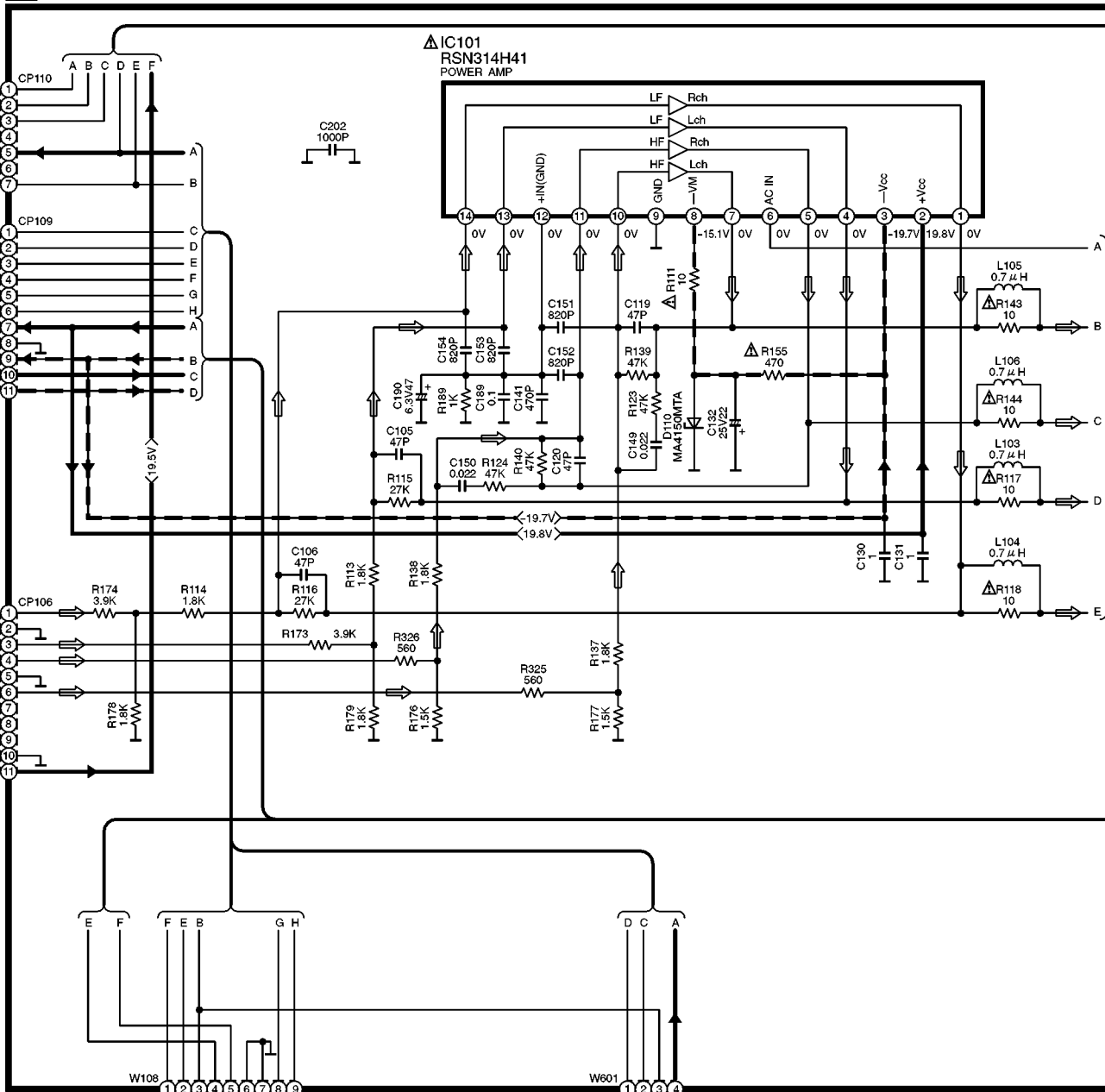

D POWER TRANSFORMER (1) CIRCUIT

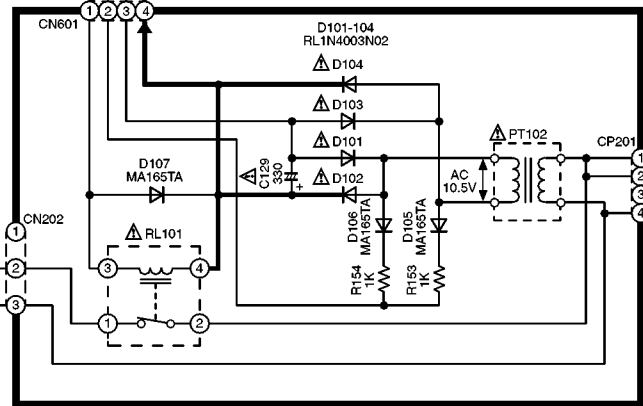

E POWER TRANSFORMER(2) CIRCUIT

SCHMATIC DIAGRAM-4

→ : POSITIVE VOLTAGE LINE
 - - - - - : NEGATIVE VOLTAGE LINE
 ⇨ : AUDIO SIGNAL LINE

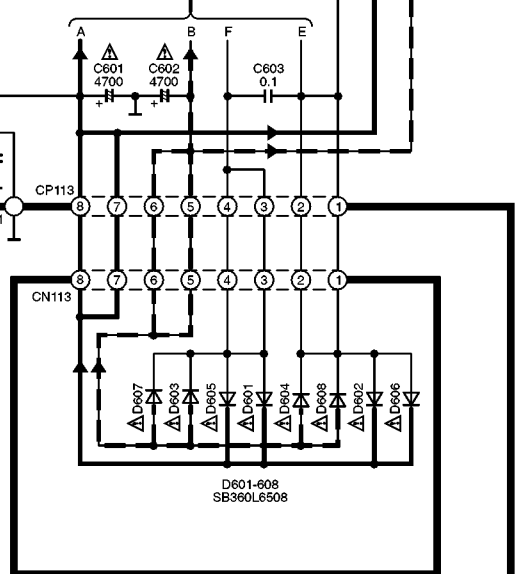
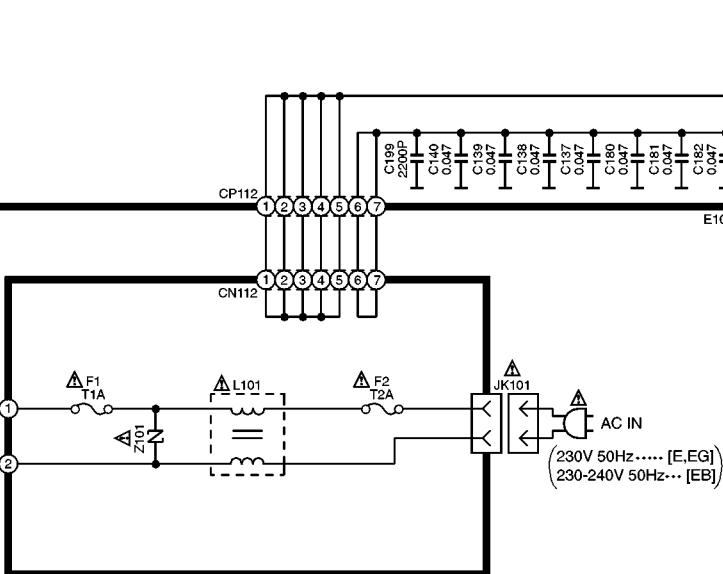
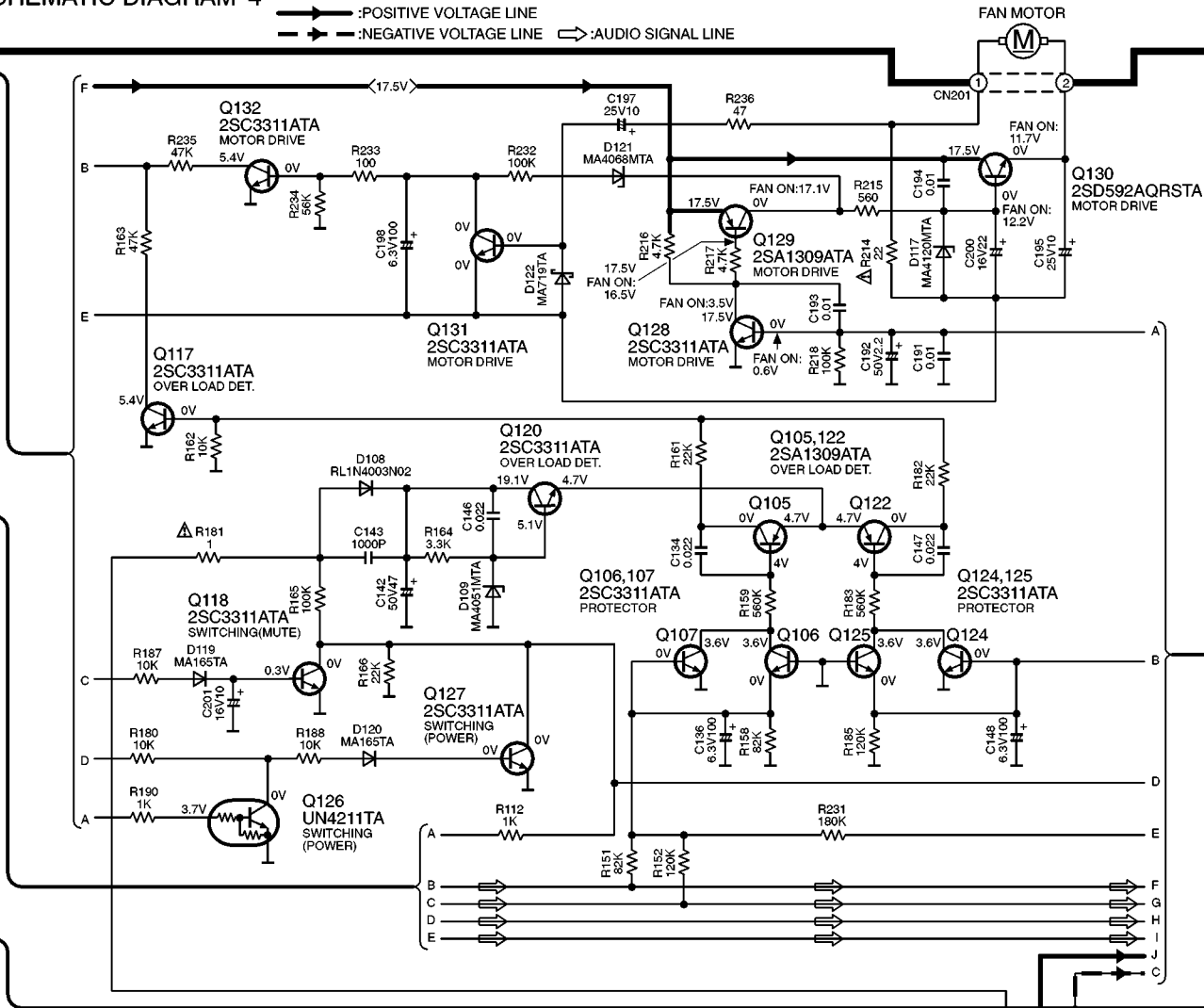

F AC IN CIRCUIT

G RECTIFIER CIRCUIT

SCHEMATIC DIAGRAM-5 C MAIN CIRCUIT

→ : POSITIVE VOLTAGE LINE
- - - - - : NEGATIVE VOLTAGE LINE ⇨ : AUDIO SIGNAL LINE

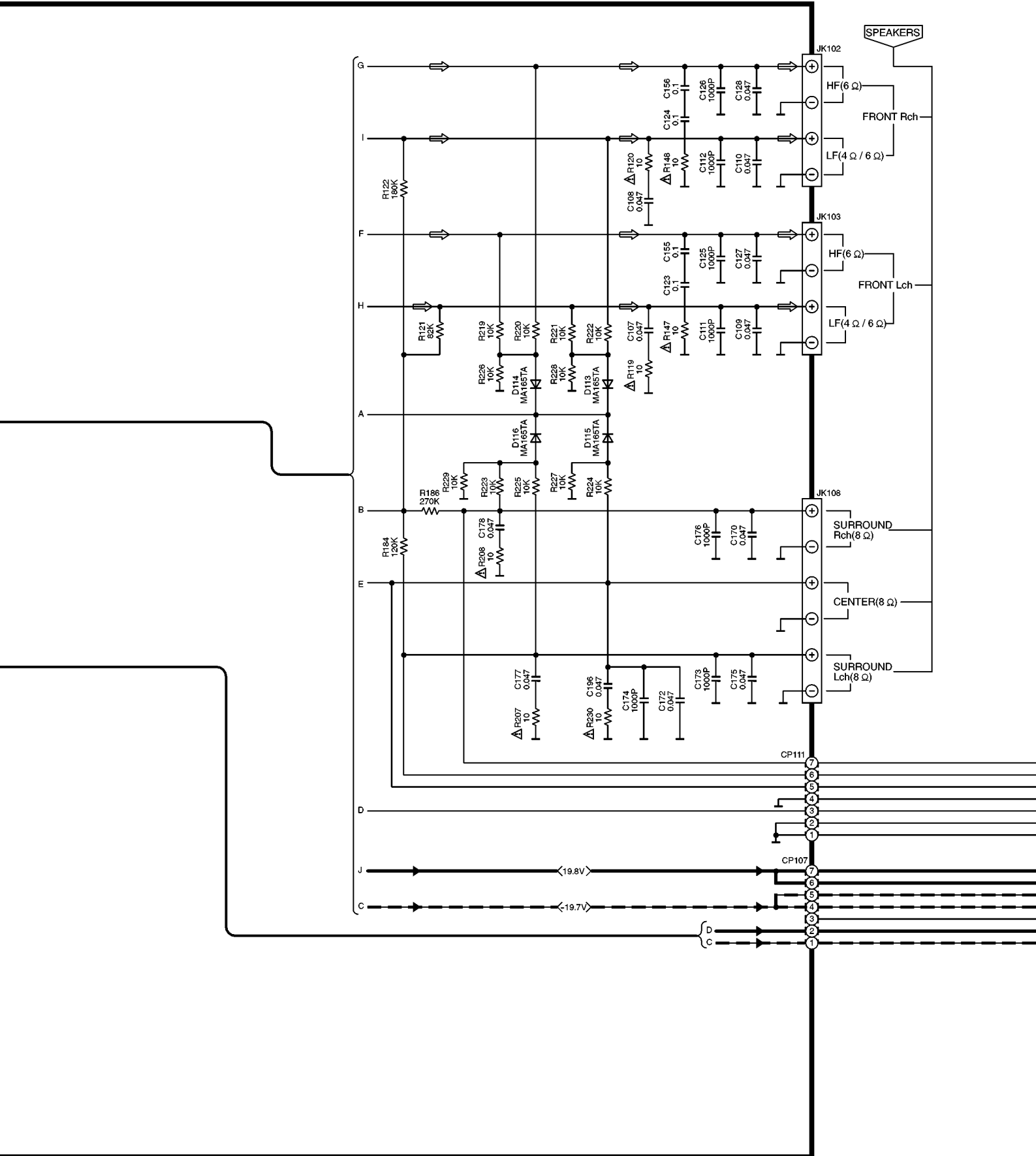

SCHEMATIC DIAGRAM-6

POWER AMP CIRCUIT

→ : POSITIVE VOLTAGE LINE
 - - - - - : NEGATIVE VOLTAGE LINE

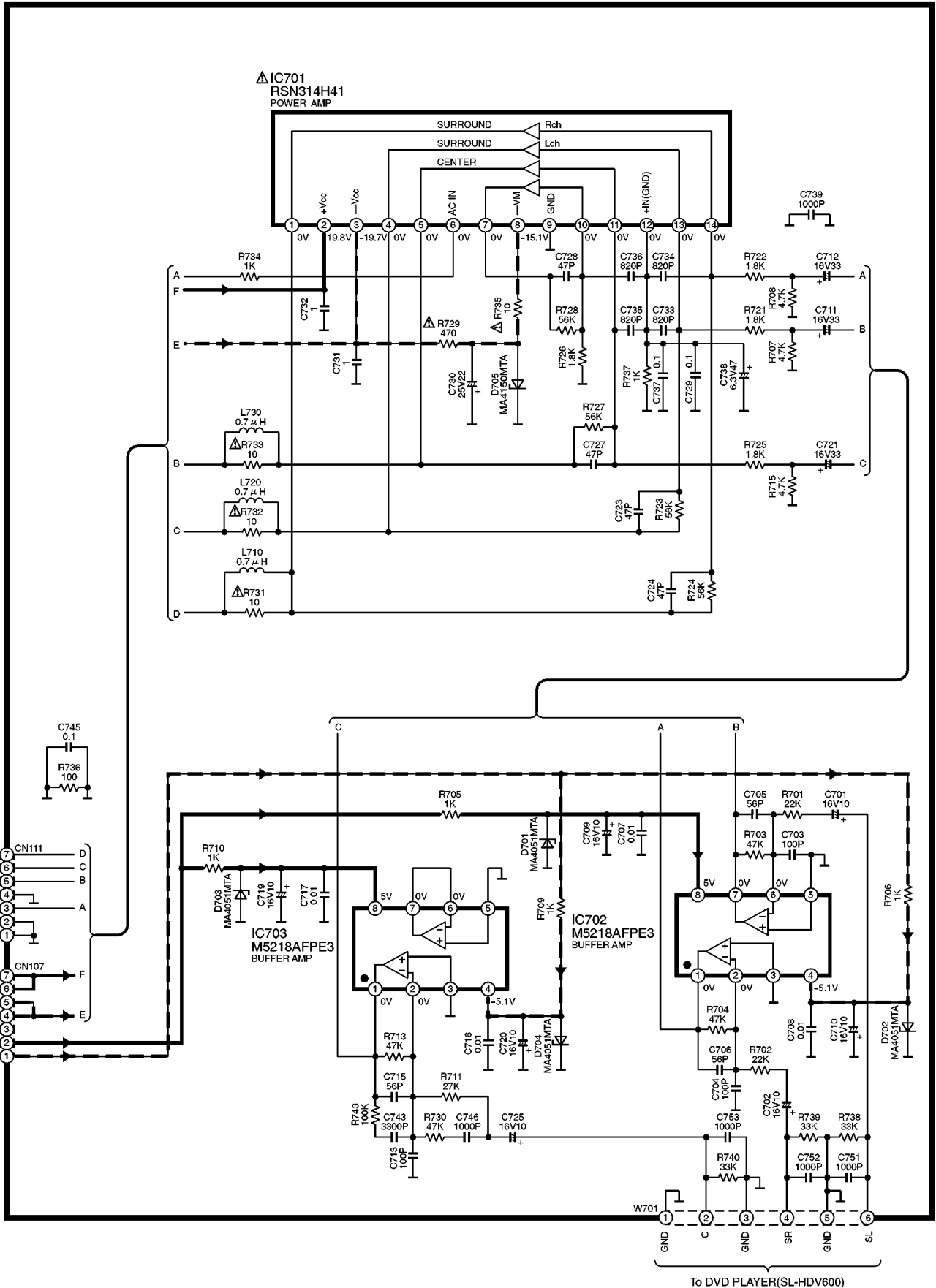

11 Printed Circuit Board Diagram

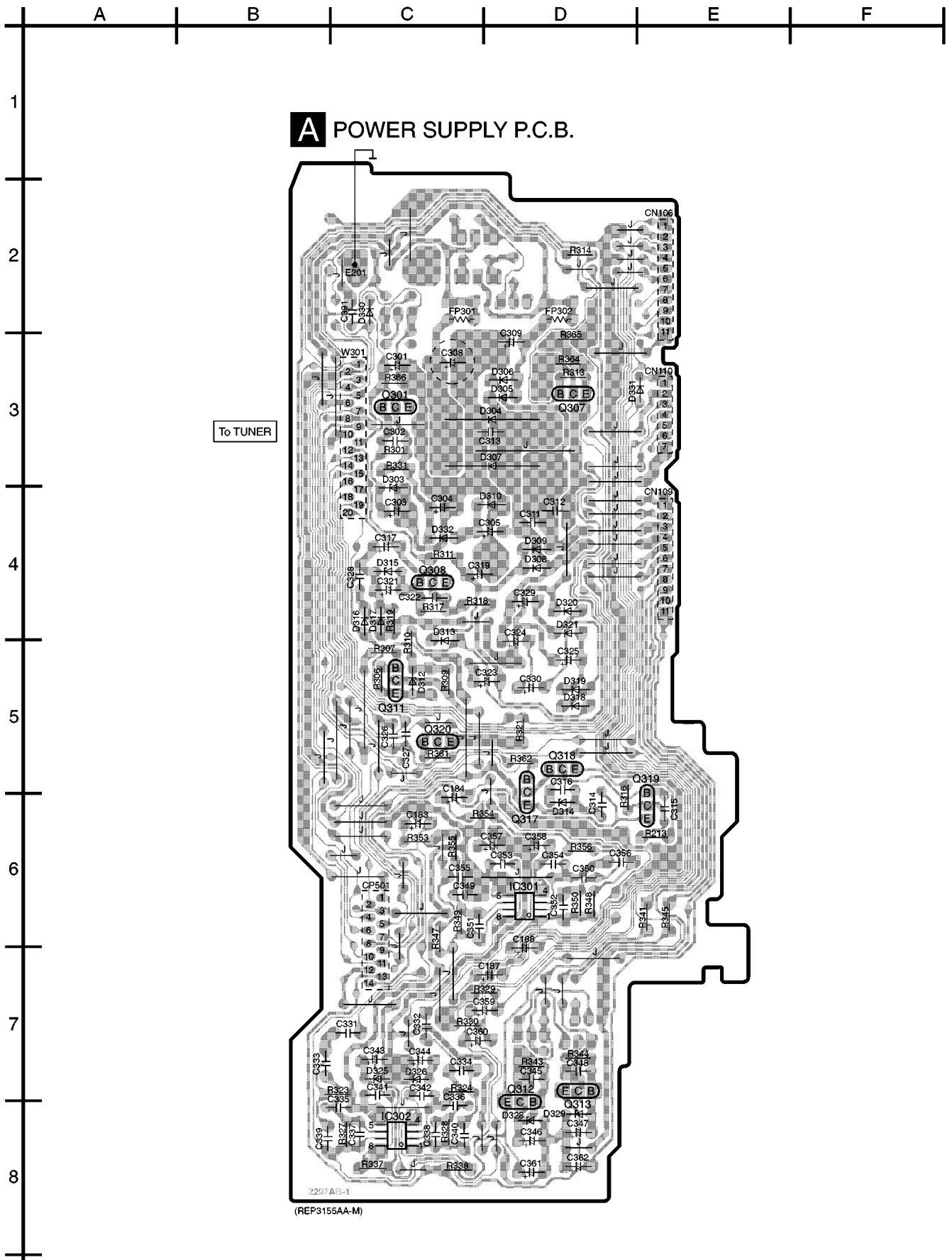

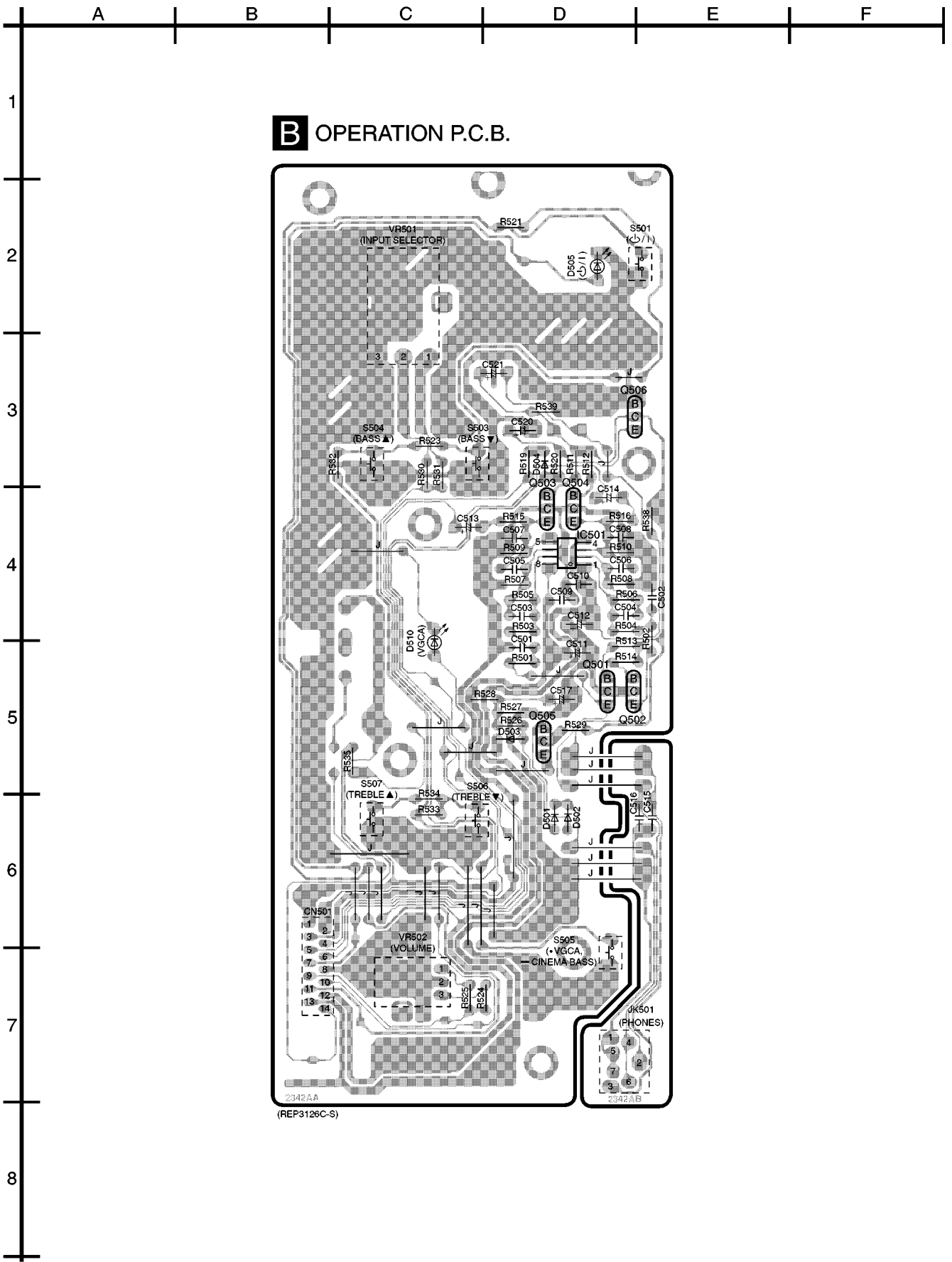

B OPERATION P.C.B.

2342AA
(REP3126C-S)

2342AB

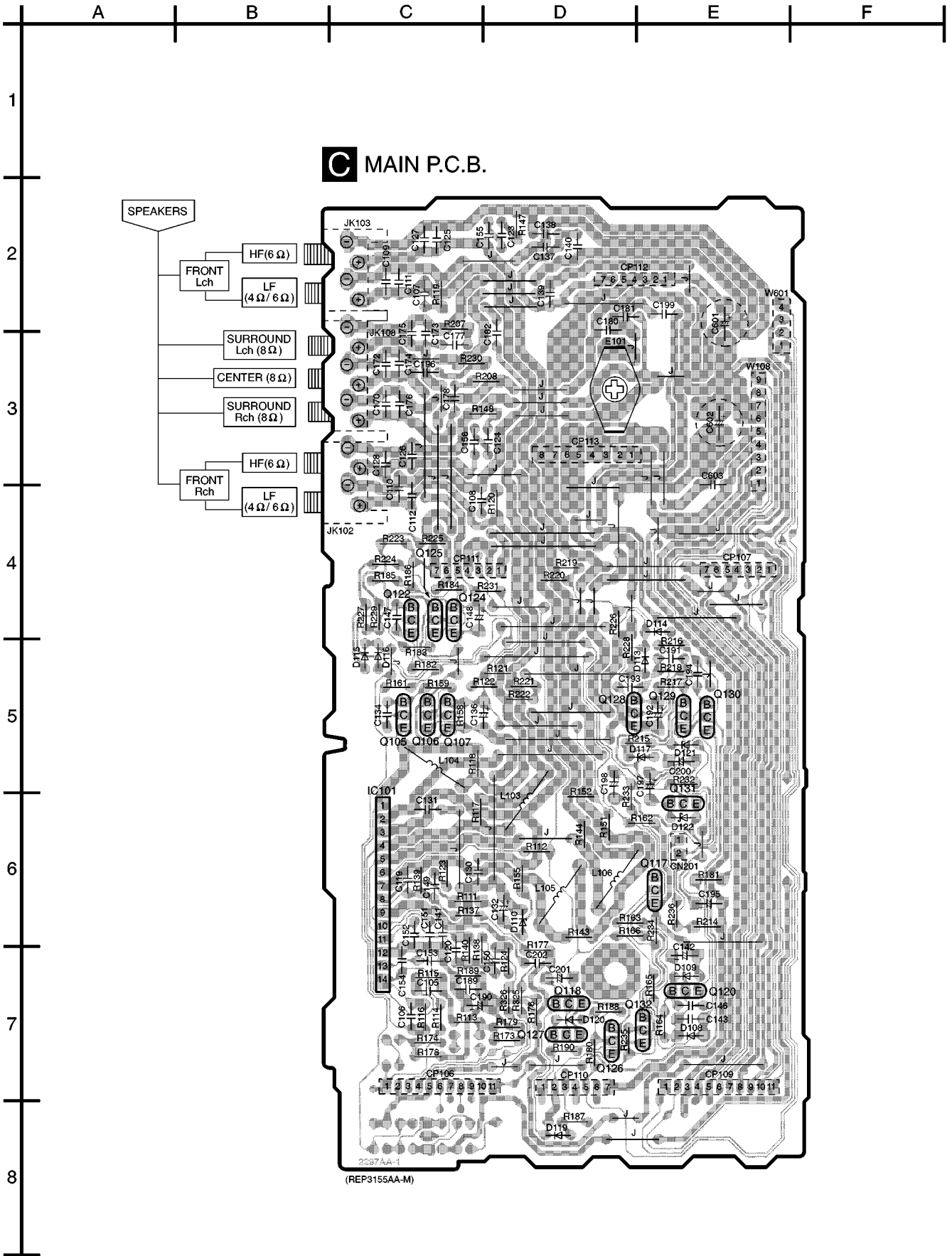

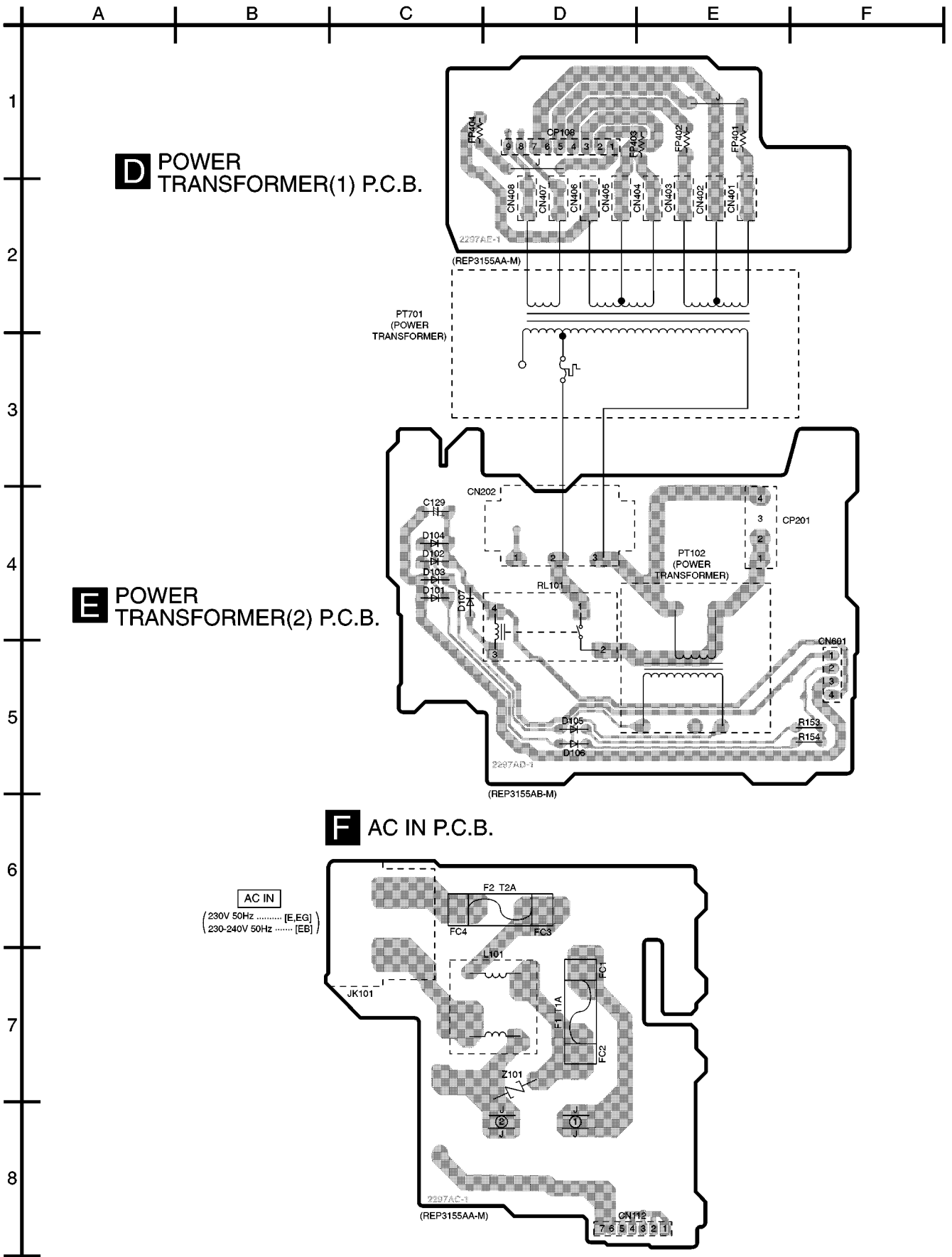

A | B | C | D | E | F

1

G RECTIFIER P.C.B.

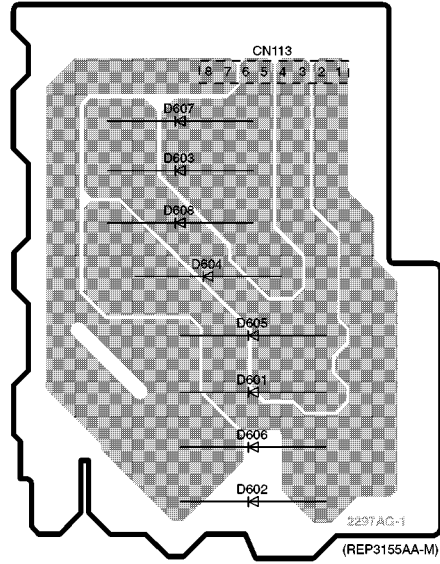

2

3

4

5

H POWER AMP P.C.B.

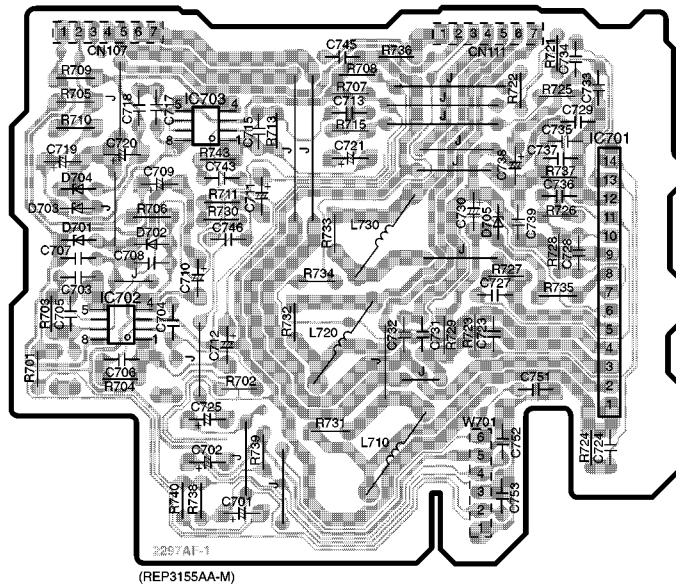

6

7

8

12 Wiring Connection Diagram

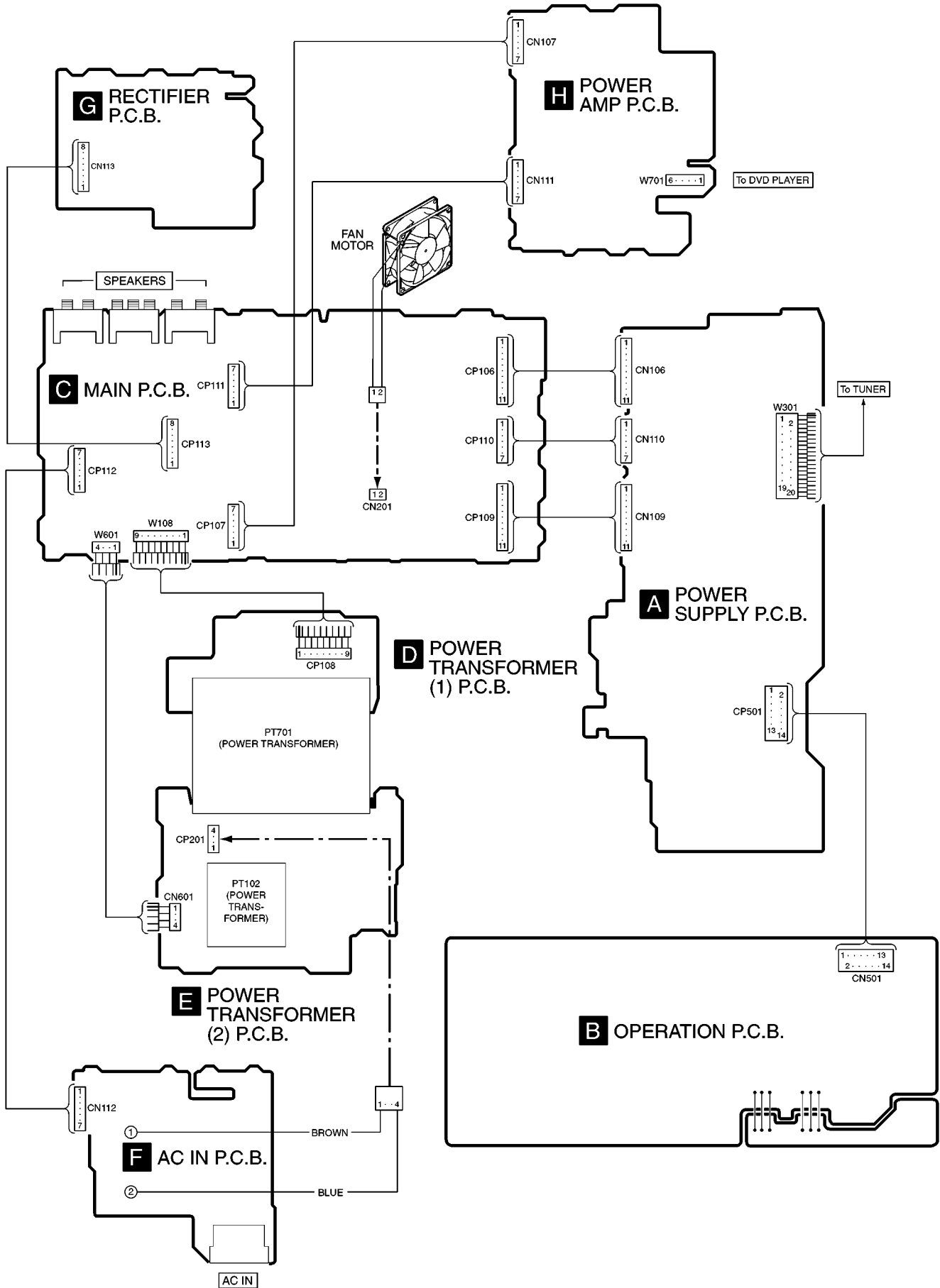

13 Block Diagram

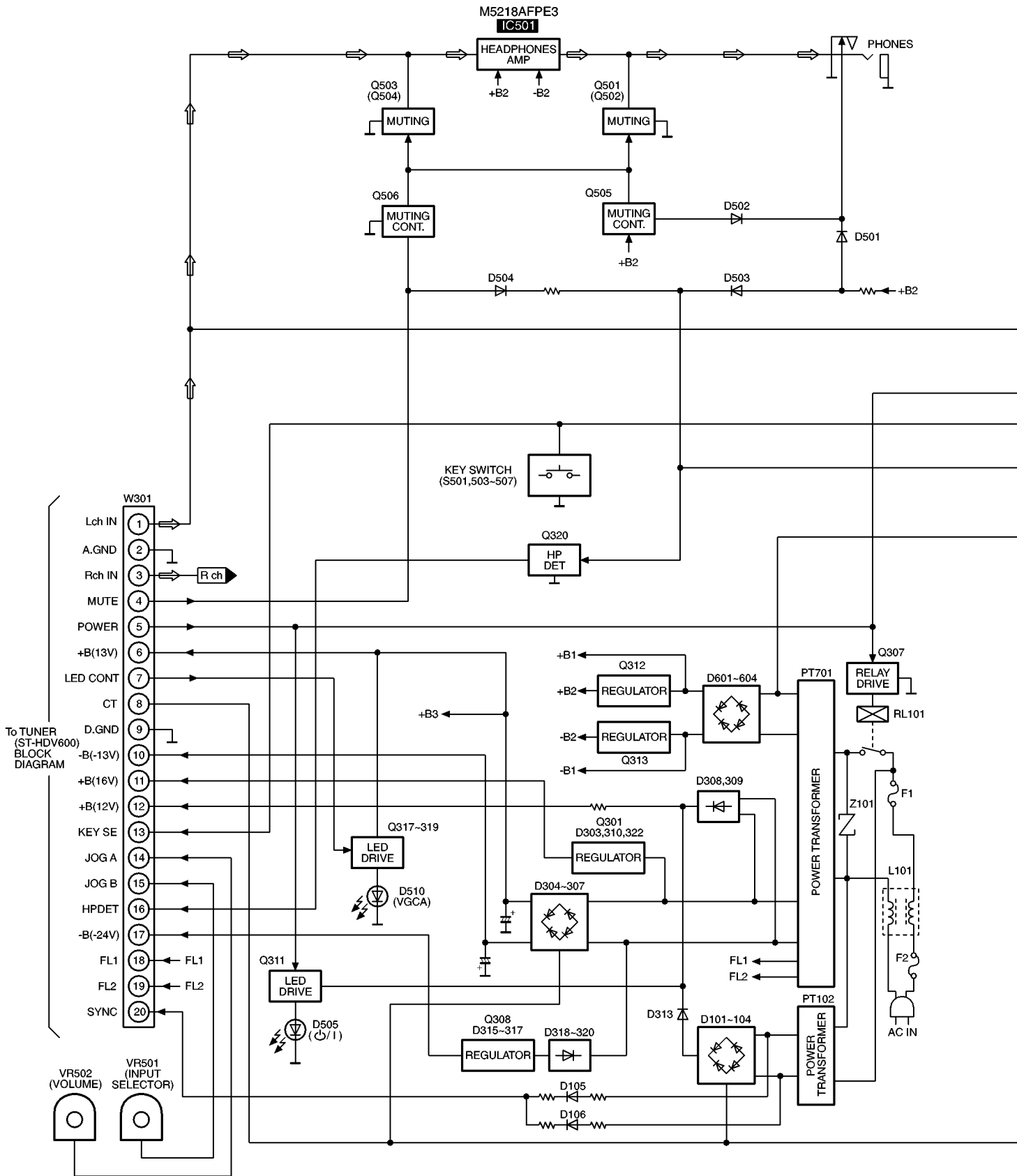

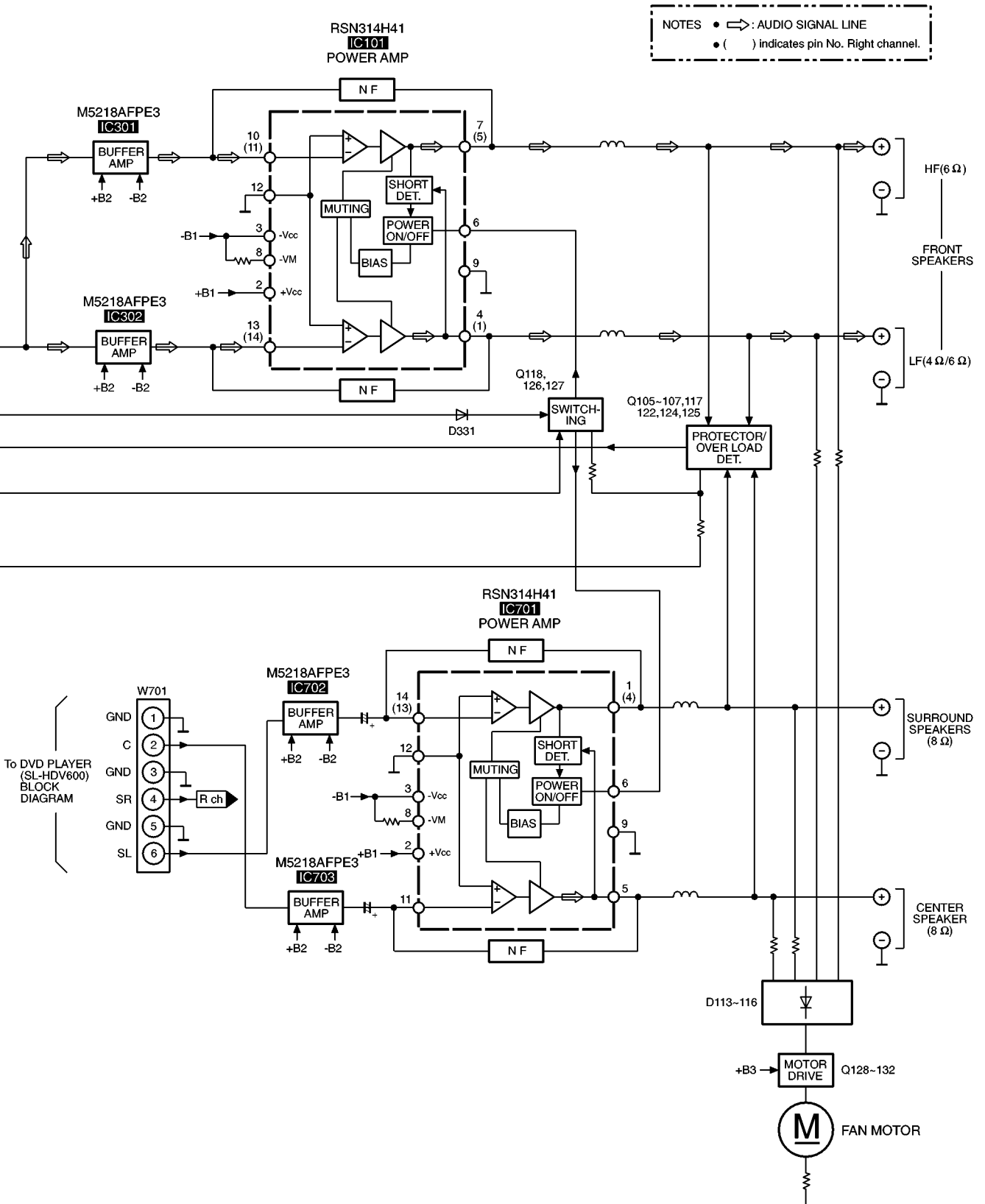

14 Replacement Parts List

Notes:

- Important safety notice:

Components identified by Δ mark have special characteristics important for safety.

Furthermore, special parts which have purposes of fire-retardant (resistors), high-quality sound (capacitors), low-noise (resistors), etc. are used.

When replacing any of components, be sure to use only manufacture's specified parts shown in the parts list.

- The <IA> <IB> <IC> <ID> marks in Remarks indicate language of instruction manual.

<IA>: Germany, Italian, French

<IB>: Netherlands, Danish, Swedish

<IC>: English

<ID>: Russian, Polish, Czech

- The parenthesized indications in the Remarks columns specify the areas. (Refer to the cover page for area.)

- The marking [RTL] indicates that Retention Time is Limited for this item. After the discontinuation of this assembly in production, the item will continue to be available for a specific period of time. The retention period of availability is dependent on the type of assembly, and in accordance with the laws governing part and product retention. After the end of this period, the assembly will no longer be available.

- All parts are supplied by MESA.

Ref. No.	Part No.	Part Name & Description	Pcs	Remarks
1	RHD30082-K	SCREW	4	
2	RGK1324-1M	SIDE PANEL(L)	1	
3	RGK1325-1M	SIDE PANEL(R)	1	
4	RMZ0339	ZNR COVER	1	
5	RKA0114-K	FOOT	4	
5-1	RKA0083-K	CUSHION	4	
6	XTB3+5JFZ	SCREW	4	
7	RGG0186B-S	FRONT PANEL	1	
8	RGL0532-Q	INDICATOR,VGCA	1	
9	RGL0541-Q	INDICATOR,STANDBY	1	
10	RGP0838A-S	SUB PANEL	1	
11	RGU1936-S	BUTTON,POWER	1	
12	RGW0358-S	KNOB,VOLUME	1	
13	RGW0363-S	KNOB,SELECTOR	1	
14	RHD26016	SCREW	1	
15	RHN90001	NUT	2	
16	XTBS26+8J	SCREW	4	
17	XTBS3+8JFZ1	SCREW	10	
18	RGN2109B-K	NAME PLATE	1	(E)
18	RGN2109A-K	NAME PLATE	1	(EB)
18	RGN2109-K	NAME PLATE	1	(EG)
19	XTB3+20JFZ	SCREW	4	
20	XTB3+8JFZ	SCREW	1	
21	XTW3+15T	SCREW	4	
22	RKM0412G-N	CABINET	1	
23	XTB3+6JFZ	SCREW	4	
24	XTB3+35JFZ	SCREW	2	
25	RGK1328-S	SIDE ORNAMENT(L)	1	
26	RGK1329-S	SIDE ORNAMENT(R)	1	
27	RGK1332-N	VOLUME ORNAMENT	2	
28	REX1081	WIRE ASS'Y	1	
29	REM0094	FAN	1	
30	REE1087	FFC WIRE	1	
31	REX0962	FLAT CABLE (W301/20P)	1	

Ref. No.	Part No.	Part Name & Description	Pcs	Remarks
32	RJS1A3404	WIRE ASS'Y (CP201/2P)	1	
A1	EUR7702080	REMOTE CONTROL UNIT	1	
A1-1	UR64EC2337E	BATTERY COVER	1	
A2	REE1057	SPEAKER CORD (RED/BLACK)	2	
A3	REE0853	SPEAKER CORD (BLUE/GRAY)	2	
A4	RSA0007	FM INDOOR ANTENNA	1	
A5	RSA0035	AM LOOP ANTENNA	1	
A6	RJA0019-1X	AC POWER SUPPLY CORD	1	(E,EG) Δ
A6	RJA0053-2X	AC POWER SUPPLY CORD	1	(EB) Δ
A7	RQT5939-D	INSTRUCTION MANUAL	1	(EG) <IA>
A7	RQT5940-H	INSTRUCTION MANUAL	1	(EG) <IB>
A7	RQT5941-B	INSTRUCTION MANUAL	1	(EB) <IC>
A7	RQT5942-E	INSTRUCTION MANUAL	1	(E) <ID>
A8	RQA0117	WARRANTY CARD	1	
A9	RQCB0169	SERVICE CENTER LIST	1	
A10	RQCA0843	SETTING GUIDE	1	(EB)
A11	SJP9009	ANTENNA PLUG ADAPTOR	1	(EB)
A12	VFA0151-2	SKART PLUG ADAPTOR	1	K1JZ24D00001
A13	RJL1P019B15	VIDEO CONNECTION CABLE	1	K2JA2A000018
A14	REX0941	SURROUND CABLE	1	
C105,06	ECBT1H470J5	50V 47P	2	F1D1H470A006
C107-10	ECBT1H473KB5	50V 0.047U	4	
C111,12	ECBT1H102KB5	50V 1000P	2	F1D1H102A012
C119,20	ECBT1H470J5	50V 47P	2	F1D1H470A006
C123,24	ECBT1H104ZF5	50V 0.1U	2	F1E1H104A001
C125,26	ECBT1H102KB5	50V 1000P	2	F1D1H102A012
C127,28	ECBT1H473KB5	50V 0.047U	2	
C129	ECA1CM331	330U	1	Δ
C130,31	ECBT1H105ZF5	50V 1U	2	F1E1H105A001
C132	ECA1EAK220XB	25V 22U	1	
C134	ECBT1H223KB5	50V 0.022U	1	F1D1H223A012
C136	ECA0JAK101XB	6.3V 100U	1	
C137-40	ECBT1H473KB5	50V 0.047U	4	
C141	ECBT1H471KB5	50V 470P	1	F1D1H471A012
C142	ECA1HAM470XB	50V 47U	1	
C143	ECKR2H102ZF5	500V 1000P	1	
C146,47	ECBT1H223KB5	50V 0.022U	2	F1D1H223A012
C148	ECA0JAK101XB	6.3V 100U	1	
C149,50	ECBT1H223KB5	50V 0.022U	2	F1D1H223A012
C151-54	ECBT1H821KB5	50V 820P	4	F1D1H821A012
C155,56	ECBT1H104ZF5	50V 0.1U	2	F1E1H104A001
C170	ECBT1H473KB5	50V 0.047U	1	
C172	ECBT1H473KB5	50V 0.047U	1	
C173,74	ECBT1H102KB5	50V 1000P	2	F1D1H102A012
C175	ECBT1H473KB5	50V 0.047U	1	
C176	ECBT1H102KB5	50V 1000P	1	F1D1H102A012
C177,78	ECBT1H473KB5	50V 0.047U	2	
C180-82	ECBT1H473KB5	50V 0.047U	3	
C183,84	ECA1CAK100XB	16V 10U	2	
C187,88	ECA1CAK330XB	16V 33U	2	
C189	ECBT1H104KB5	50V 0.1U	1	
C190	RCE0JKA470BG	6.3V 47U	1	F2A0J470A014
C191	ECBT1H103KB5	50V 0.01U	1	
C192	ECA1HAK2R2XB	50V 2.2U	1	
C193,94	ECBT1H103KB5	50V 0.01U	2	
C195	ECA1EAK100XB	25V 10U	1	
C196	ECBT1H473KB5	50V 0.047U	1	
C197	ECA1EAK100XB	25V 10U	1	
C198	ECA0JAK101XB	6.3V 100U	1	
C199	ECBT1C222KR5	16V 2200P	1	
C200	ECA1CAK220XB	16V 22U	1	

Ref. No.	Part No.	Part Name & Description	Pcs	Remarks
C201	ECA1CAK100XB	16V 10U	1	
C202	ECBT1H102KB5	50V 1000P	1	F1D1H102A012
C301	ECA1EAK4R7XB	25V 4.7U	1	
C302	ECBT1H103KB5	50V 0.01U	1	
C303	ECA1EAM101XB	25V 100U	1	
C304	ECA1HMI01	100U	1	△
C305	ECA1EAM101XB	100U	1	△
C308	ECA1EM222	2200U	1	△
C309	RCE1EM471BV	470U	1	△
C311	ECR1H103ZF5	50V 0.01U	1	F1B1H1030001
C312,13	ECBT1H103KB5	50V 0.01U	2	
C314	ECBT1H104KB5	50V 0.1U	1	
C315	ECBT1H103KB5	50V 0.01U	1	
C316	ECBT1H104ZF5	50V 0.1U	1	F1E1H104A001
C317	ECA1VM101	35V 100U	1	
C319	ECA1EAM331XB	330U	1	△
C321	RCE1VKA100BG	35V 10U	1	F2A1V1000011
C322	ECBT1H103KB5	50V 0.01U	1	
C323	ECA2AM100	10U	1	△
C324	ECA1JAM101XB	100U	1	△
C325	ECA1HAM470XB	47U	1	△
C326,27	ECBT1H101KB5	50V 100P	2	F1D1H101A012
C328	ECBT1H104ZF5	50V 0.1U	1	F1E1H104A001
C329	ECA1EAM101XB	100U	1	△
C330	ECA1JAM101XB	100U	1	△
C331-34	ECBT1H102KB5	50V 1000P	4	F1D1H102A012
C335,36	ECBT1H101KB5	50V 100P	2	F1D1H101A012
C337,38	ECBT1H150JC5	50V 15P	2	
C339,40	ECBT1H331KB5	50V 330P	2	F1D1H331A012
C341,42	ECBT1H103KB5	50V 0.01U	2	
C343,44	ECA1CAK100XB	16V 10U	2	
C345	ECBT1H103KB5	50V 0.01U	1	
C346,47	ECA1EAK100XB	25V 10U	2	
C348	ECBT1H103KB5	50V 0.01U	1	
C349,50	ECBT1H101KB5	50V 100P	2	F1D1H101A012
C351,52	ECBT1C152KR5	16V 1500P	2	
C353,54	ECBT1H103KB5	50V 0.01U	2	
C355,56	ECBT1C392KR5	16V 3900P	2	F1D1C392A010
C357,58	ECA1EAK100XB	25V 10U	2	
C359,60	ECEA1HRAR22B	50V 0.22U	2	
C361,62	ECA1EAK100XB	25V 10U	2	
C391	ECBT1H471KB5	50V 470P	1	F1D1H471A012
C501,02	ECBT1H103KB5	50V 0.01U	2	
C503-06	ECBT1H101KB5	50V 100P	4	F1D1H101A012
C507,08	ECBT1H331KB5	50V 330P	2	F1D1H331A012
C509,10	ECBT1H103KB5	50V 0.01U	2	
C511,12	ECA1EAK4R7XB	25V 4.7U	2	
C513,14	ECA1HAK010XI	50V 1U	2	ECA1HAK010XB
C515,16	ECBT1H473ZF5	50V 0.047U	2	
C517	ECA0JAK22LXB	6.3V 220U	1	
C520,21	ECA1HAK010XI	50V 1U	2	ECA1HAK010XB
C601,02	ECA1EAM472XE	4700	2	△
C603	ECQE1104KF3	100V 0.1U	1	
C701,02	ECA1CAK100XB	16V 10U	2	
C703,04	ECBT1H101KB5	50V 100P	2	F1D1H101A012
C705,06	ECBT1H560J5	50V 56P	2	ECBT1H560J3
C707,08	ECBT1H103KB5	50V 0.01U	2	
C709,10	ECA1CAK100XB	16V 10U	2	
C711,12	ECA1CAK330XB	16V 33U	2	
C713	ECBT1H101KB5	50V 100P	1	F1D1H101A012
C715	ECBT1H560J5	50V 56P	1	ECBT1H560J3
C717,18	ECBT1H103KB5	50V 0.01U	2	
C719,20	ECA1CAK100XB	16V 10U	2	
C721	ECA1CAK330XB	16V 33U	1	
C723,24	ECBT1H470J5	50V 47P	2	F1D1H470A006
C725	ECA1CAK100XB	16V 10U	1	
C727,28	ECBT1H470J5	50V 47P	2	F1D1H470A006
C729	ECBT1H104ZF5	50V 0.1U	1	F1E1H104A001
C730	ECA1EAK220XB	25V 22U	1	
C731,32	ECBT1H105ZF5	50V 1U	2	F1E1H105A001
C733-36	ECBT1H821KB5	50V 820P	4	F1D1H821A012
C737	ECBT1H104ZF5	50V 0.1U	1	F1E1H104A001
C738	RCE0JKA470BG	6.3V 47U	1	F2A0J470A014

Ref. No.	Part No.	Part Name & Description	Pcs	Remarks
C739	ECBT1H102KB5	50V 1000P	1	F1D1H102A012
C743	ECBT1C332KR5	16V 3300P	1	
C745	ECBT1H104KB5	50V 0.1U	1	
C746	ECBT1H102KB5	50V 1000P	1	F1D1H102A012
C751-53	ECBT1H102KB5	50V 1000P	3	F1D1H102A012
CN106	RJU100W11	CONNECTOR (11P)	1	
CN107	RJU100W07	CONNECTOR (7P)	1	K1KB07A00018
CN109	RJU100W11	CONNECTOR (11P)	1	
CN110-12	RJU100W07	CONNECTOR (7P)	3	K1KB07A00018
CN113	SJT30845JQ	CONNECTOR	1	K1KA08B00125
CN201	SJT3213	CONNECTOR	1	K1KA02A00008
CN202	SJS305-1	CONNECTOR	1	
CN401-08	RJS1A1101T1	CONNECTOR (1P)	8	
CN501	RJS1A6214-1	CONNECTOR (14P)	1	K1MN14C00002
CN601	RJS1A6604T1	CONNECTOR (4P)	1	K1MP04A00008
CP107	RJT100W07	CONNECTOR (7P)	1	K1KA07A00082
CP108	RJS9T6ZA	CONNECTOR (9P)	1	K1MP09B00005
CP110-12	RJT100W07	CONNECTOR (7P)	3	K1KA07A00082
CP113	SJS50878JQ	CONNECTOR (8P)	1	K1KB08A00060
CP201	RJPLA4204-1	CONNECTOR (4P)	1	K1KA03A00143
CP501	RJS1A6714-Q	CONNECTOR (14P)	1	K1MN14B00054
D101-04	RL1N4003N02	DIODE	4	△
D105-07	MA165	DIODE	3	MA2C165
D108	RL1N4003N02	DIODE	1	
D109	MA4051M	DIODE	1	MAZ40510M
D110	MA4150M	DIODE	1	MAZ41500M
D113-16	MA165	DIODE	4	MA2C165
D117	MA4120M	DIODE	1	MAZ41200M
D119,20	MA165	DIODE	2	MA2C165
D121	MA4068M	DIODE	1	MAZ40680M
D122	MA719TA	DIODE	1	MAZC71900A
D303	MA4160M	DIODE	1	MAZ41600M △
D304	1N5402BF	DIODE	1	△
D305,06	RL1N4003N02	DIODE	2	△
D307	1N5402BF	DIODE	1	△
D308-10	RL1N4003N02	DIODE	3	△
D312	MA4051M	DIODE	1	MAZ40510M
D313	RL1N4003N02	DIODE	1	
D314	MA4091M	DIODE	1	MAZ40910M
D315	MA4240H	DIODE	1	MAZ42400H △
D316,17	RL1N4003N02	DIODE	2	
D318-22	RL1N4003N02	DIODE	5	△
D325,26	MA4075M	DIODE	2	MAZ40750M
D328,29	MA4120M	DIODE	2	MAZ41200M △
D330,31	MA165	DIODE	2	MA2C165
D501-04	MA165	DIODE	4	MA2C165
D505	SLR-325VC	DIODE	1	B3AAA0000487
D510	SLR-325MC	LED	1	B3ABA0000187
D601-08	SB360L6508	DIODE	8	B0JAPG000014 △
D701-04	MA4051M	DIODE	4	MAZ40510M
D705	MA4150M	DIODE	1	MAZ41500M
F1	XBA2C10TB0S	FUSE	1	K5D102BL0004 △
F2	XBA2C20TB0	FUSE	1	K5D202BL0001 △
FP301,02	RSFMB40KT-L	FUSE PROTECTOR	2	K5G402A00010 △
FP401,02	RSFMB70KT-L	FUSE PROTECTOR	2	△
FP403,04	RSFMB50KT-L	FUSE PROTECTOR	2	K5G502A00022 △
IC101	RSN314H41	IC	1	△
IC301,02	M5218AFPE3	IC	2	C0ABBB000163
IC501	M5218AFPE3	IC	1	C0ABBB000163
IC701	RSN314H41	IC	1	△
IC702,03	M5218AFPE3	IC	2	C0ABBB000163

Ref. No.	Part No.	Part Name & Description	Pcs	Remarks
JK101	SJS9236-1	AC JACK	1	K2AA2B000002 △
JK102,03	K4BC04B00029	SPEAKERS	2	
JK108	RJH5603-4J	SP TERMINAL(6P)	1	K4BC06B00008
JK501	RJJ37TN01-2C	HP JACK	1	K2HC103B0106
L101	RLQZ371	LINE FILTER	1	ELF15N035AN △
L103-06	RLQYR73MW1-0	SPEAKER COIL	4	GOZZ00001606
L710	RLQYR73MW1-0	SPEAKER COIL	1	GOZZ00001606
L720	RLQYR73MW1-0	SPEAKER COIL	1	GOZZ00001606
L730	RLQYR73MW1-0	SPEAKER COIL	1	GOZZ00001606
P1	RPG5244	PACKING CASE (RS)	1	
P1	RPG5451	PACKING CASE (SE)	1	
P1	RPG5453	PACKING CASE (SL)	1	
P1	RPG5245	PACKING CASE (ST)	1	
P2	RPN1390	PAD 1 (RS)	1	
P2	RPN1429	PAD 1 (SE)	1	
P2	RPN1430	PAD 1 (SL)	1	
P2	RPN1389	PAD 1 (ST)	1	
P3	SPP740-1	POLY BAG	4	
P4	RPG5454	PACKING CASE (SYSTEM)	1	(E)
P4	RPG5455	PACKING CASE (SYSTEM)	1	(EB)
P4	RPG5452	PACKING CASE (SYSTEM)	1	(EG)
P5	RPQ1187	PAD 2	1	
P6	RPF0139	PROTECTION BAG (F.B.)	1	
P7	RPQ1188	PAD 3	1	
PCB1	REP3155A-M	P.C.B.ASS`Y	1	[RTL]
PCB2	REP3126C-S	P.C.B.ASS`Y	1	[RTL]
PT102	RTP1H3E001	POWER TRANSFORMER	1	△
PT701	ETP69VPUG1UA	TRANSFOMER	1	△
PT701	ETP69VPUG1WA	TRANSFOMER	1	(EB) △
Q105	2SA1309ATA	TRANSISTOR	1	2SA1309AWA
Q106,07	2SC3311ATA	TRANSISTOR	2	2SC3311A0A
Q117,18	2SC3311ATA	TRANSISTOR	2	2SC3311A0A
Q120	2SC3311ATA	TRANSISTOR	1	2SC3311A0A
Q122	2SA1309ATA	TRANSISTOR	1	2SA1309AWA
Q124,25	2SC3311ATA	TRANSISTOR	2	2SC3311A0A
Q126	UN4211	TRANSISTOR	1	UNR4211
Q127,28	2SC3311ATA	TRANSISTOR	2	2SC3311A0A
Q129	2SA1309ATA	TRANSISTOR	1	2SA1309AWA
Q130	2SD592AR	TRANSISTOR	1	2SD0592AR
Q131,32	2SC3311ATA	TRANSISTOR	2	2SC3311A0A
Q301	2SC3940AQSTA	TRANSISTOR	1	2SC3940ARA △
Q307	2SC3311ATA	TRANSISTOR	1	2SC3311A0A
Q308	2SB621A-R	TRANSISTOR	1	2SB0621AH △
Q311	2SC3311ATA	TRANSISTOR	1	2SC3311A0A
Q312	2SD2137PQTA	TRANSISTOR	1	2SD21370PA △
Q313	2SB1417PQTA	TRANSISTOR	1	2SB14170JA △
Q317	UN4211	TRANSISTOR	1	UNR4211
Q318	UN4111	TRANSISTOR	1	UNR4111
Q319	2SC3311ATA	TRANSISTOR	1	2SC3311A0A
Q320	UN4211	TRANSISTOR	1	UNR4211
Q501-04	2SC3327A	TRANSISTOR	4	
Q505	UN4111	TRANSISTOR	1	UNR4111
Q506	UN4115	TRANSISTOR	1	UNR4115
R111	ERD2FCG100	10	1	△
R112	ERDS2FJ102	1/4W 1K	1	
R113,14	ERDS2FJ182	1/4W 1.8K	2	
R115,16	ERDS2FJ273	1/4W 27K	2	
R117,18	ERDS2FJ100	10	2	△

Ref. No.	Part No.	Part Name & Description	Pcs	Remarks
R119,20	ERDS1FJ100	10	2	△
R121	ERDS2FJ823	1/4W 82K	1	
R122	ERDS2FJ184	1/4W 180K	1	
R123,24	ERDS2FJ473	1/4W 47K	2	
R137,38	ERDS2FJ182	1/4W 1.8K	2	
R139,40	ERDS2FJ473	1/4W 47K	2	
R143,44	ERDS2FJ100	10	2	△
R147,48	ERDS1FJ100	10	2	△
R151	ERDS2FJ823	1/4W 82K	1	
R152	ERDS2FJ124	1/4W 120K	1	
R153,54	ERDS2FJ102	1/4W 1K	2	
R155	ERDS1FJ471	470	1	△
R158	ERDS2FJ823	1/4W 82K	1	
R159	ERDS2FJ564	1/4W 560K	1	
R161	ERDS2FJ223	1/4W 22K	1	
R162	ERDS2FJ103	1/4W 10K	1	
R163	ERDS2FJ473	1/4W 47K	1	
R164	ERDS2FJ332	1/4W 3.3K	1	
R165	ERDS2FJ104	1/4W 100K	1	
R166	ERDS2FJ223	1/4W 22K	1	
R173,74	ERDS2FJ392	1/4W 3.9K	2	
R176,77	ERDS2FJ152	1/4W 1.5K	2	
R178,79	ERDS2FJ182	1/4W 1.8K	2	
R180	ERDS2FJ103	1/4W 10K	1	
R181	ERDS2FJ1R0	1	1	△
R182	ERDS2FJ223	1/4W 22K	1	
R183	ERDS2FJ564	1/4W 560K	1	
R184,85	ERDS2FJ124	1/4W 120K	2	
R186	ERDS2FJ274	1/4W 270K	1	
R187,88	ERDS2FJ103	1/4W 10K	2	
R189,90	ERDS2FJ102	1/4W 1K	2	
R207,08	ERDS1FJ100	10	2	△
R213	ERD2FCG100	10	1	△
R214	ERDS2FJ220	22	1	△
R215	ERDS2FJ561	1/4W 560	1	
R216,17	ERDS2FJ472	1/4W 4.7K	2	
R218	ERDS2FJ104	1/4W 100K	1	
R219-29	ERDS2FJ103	1/4W 10K	11	
R230	ERDS1FJ100	10	1	△
R231	ERDS2FJ184	1/4W 180K	1	
R232	ERDS2FJ104	1/4W 100K	1	
R233	ERDS2FJ101	1/4W 100	1	
R234	ERDS2FJ563	1/4W 56K	1	
R235	ERDS2FJ473	1/4W 47K	1	
R236	ERDS2FJ470	1/4W 47	1	
R301	ERDS2FJ392	1/4W 3.9K	1	
R306	ERDS2FJ473	1/4W 47K	1	
R307	ERDS2FJ103	1/4W 10K	1	
R309	ERDS2FJ331	1/4W 330	1	
R310	ERDS2FJ681	1/4W 680	1	
R311	ERDS1FJ3R3	3.3	1	△
R313	ERDS2FJ473	1/4W 47K	1	
R314	ERDS2FJ392	1/4W 3.9K	1	
R316	ERDS2FJ102	1/4W 1K	1	
R317	ERDS2FJ472	1/4W 4.7K	1	
R318	ERDS2FJ100	10	1	△
R319	ERDS2FJ101	1/4W 100	1	
R321	ERDS2FJ103	1/4W 10K	1	
R323,24	ERDS2FJ822	1/4W 8.2K	2	
R325,26	ERDS2FJ561	1/4W 560	2	
R327,28	ERDS2FJ823	1/4W 82K	2	
R329,30	ERDS2FJ102	1/4W 1K	2	
R331	ERD2FCG100	10	1	△
R337,38	ERDS2FJ331	1/4W 330	2	
R341	ERD2FCG100	10	1	△
R343,44	ERDS2FJ102	1/4W 1K	2	
R345	ERD2FCG100	10	1	△
R347,48	ERDS2FJ103	1/4W 10K	2	
R349,50	ERDS2FJ104	1/4W 100K	2	
R353-56	ERDS2FJ103	1/4W 10K	4	
R361,62	ERDS2FJ102	1/4W 1K	2	
R364,65	ERDS2FJ560	1/4W 56	2	
R366	ERDS2FJ103	1/4W 10K	1	

Ref. No.	Part No.	Part Name & Description	Pcs	Remarks
R501-04	ERDS2FJ470	1/4W 47	4	
R505,06	ERDS2FJ153	1/4W 15K	2	
R507,08	ERDS2FJ332	1/4W 3.3K	2	
R509,10	ERDS2FJ223	1/4W 22K	2	
R511-14	ERDS2FJ102	1/4W 1K	4	
R515,16	ERDS2FJ223	1/4W 22K	2	
R519,20	ERDS2FJ102	1/4W 1K	2	
R521	ERDS2FJ821	1/4W 820	1	
R523	ERDS2FJ102	1/4W 1K	1	
R524	ERDS2FJ153	1/4W 15K	1	
R525	ERDS2FJ103	1/4W 10K	1	
R526	ERDS2FJ102	1/4W 1K	1	
R527	ERDS2FJ222	1/4W 2.2K	1	
R528,29	ERDS2FJ472	1/4W 4.7K	2	
R530	ERDS2FJ153	1/4W 15K	1	
R531	ERDS2FJ103	1/4W 10K	1	
R532	ERDS2FJ122	1/4W 1.2K	1	
R533	ERDS2FJ152	1/4W 1.5K	1	
R534	ERDS2FJ182	1/4W 1.8K	1	
R535	ERDS2FJ471	1/4W 470	1	
R538	ERDS2FJ474	1/4W 470K	1	
R539	ERDS2FJ154	1/4W 150K	1	
R701,02	ERDS2FJ223	1/4W 22K	2	
R703,04	ERDS2FJ473	1/4W 47K	2	
R705,06	ERDS2FJ102	1/4W 1K	2	
R707,08	ERDS2FJ472	1/4W 4.7K	2	
R709,10	ERDS2FJ102	1/4W 1K	2	
R711	ERDS2FJ273	1/4W 27K	1	
R713	ERDS2FJ473	1/4W 47K	1	
R715	ERDS2FJ472	1/4W 4.7K	1	
R721,22	ERDS2FJ182	1/4W 1.8K	2	
R723,24	ERDS2FJ563	1/4W 56K	2	
R725,26	ERDS2FJ182	1/4W 1.8K	2	
R727,28	ERDS2FJ563	1/4W 56K	2	
R729	ERDS1FJ471	470	1	△
R730	ERDS2FJ473	1/4W 47K	1	
R731-33	ERDS2FJ100	10	3	△
R734	ERDS2FJ102	1/4W 1K	1	
R735	ERD2FCG100	10	1	△
R736	ERDS2FJ101	1/4W 100	1	
R737	ERDS2FJ102	1/4W 1K	1	
R738-40	ERDS2FJ333	1/4W 33K	3	
R743	ERDS2FJ104	1/4W 100K	1	
RL101	RSY0040M-0	RELAY	1	△
S501	EVQ11G05R	SW,POWER	1	
S503-07	EVQ11G05R	SW,PUSH	5	
VR501	K9AA012A0003	V.R.,INPUT SELECTOR	1	
VR502	EVEKC2F2524B	V.R.,VOLUME	1	
Z101	ERZV10V511CS	ZNR	1	

15 Cabinet Parts Location

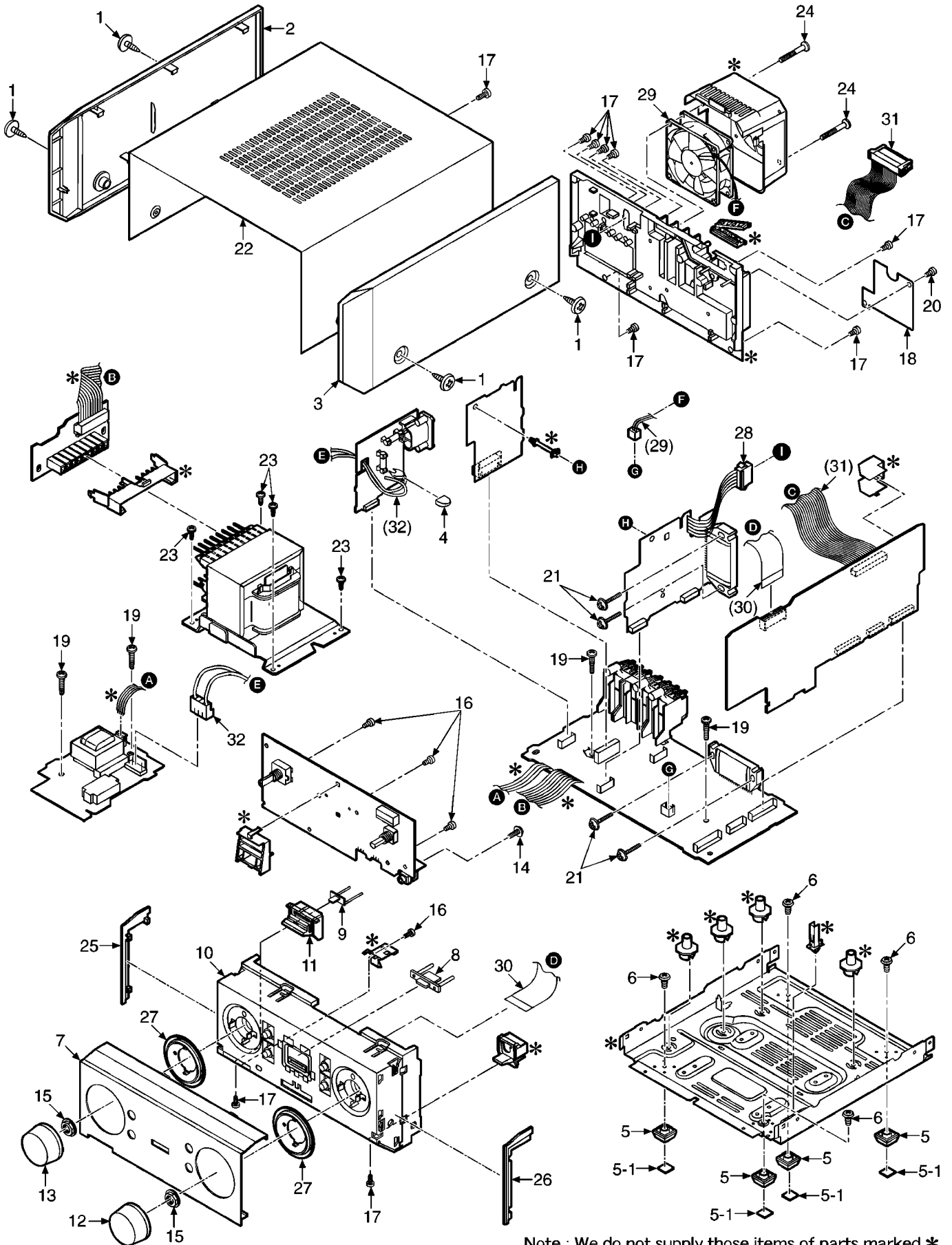

Note : We do not supply those items of parts marked *.

16 Packaging

