

Service Manual

Equalizer

SH-8044

Stereo Graphic Equalizer

Color

(K) Black Type
(S) Silver Type



Color	Area
(K) (S)	[E] Scandinavia, Switzerland
(K) (S)	[EH] Holland
(K) (S)	[EB] Belgium
(K) (S)	[EF] France
(K) (S)	[EK] United Kingdom
(K) (S)	[EGA] . . . F.R. Germany
(K) (S)	[Ei] Italy
(K) (S)	[PA] Far East PX
(K) (S)	[PE] European Military
(K) (S)	[XL] Australia
(K) (S)	[XA] Asia, Latin America, Middle Near East, Africa & Oceania
(K) (S)	[NX] Tourist in Japan

Please use this manual together with the service manual for Model No. SH-8044, Order No. HAD84072836C1.

SPECIFICATIONS

(DIN 45 500)

Frequency response (center position)	: 5 Hz~100 kHz, -1 dB
Maximum output voltage	: 8 V (1 kHz, THD 0.01%)
Rated output voltage	: 1 V
Rated total harmonic distortion	: 0.005% (20 Hz~20 kHz) 0.003% (1 kHz)
Input sensitivity	: 1 V
Signal-to-noise ratio	: 100 dB (110 dB, 1HF A)
Maximum input voltage	: 8 V (1 kHz)
Input impedance	: 33 k Ω
Gain	: 0 \pm 1 dB
Channel balance 250 Hz~6300 Hz	: \pm 0.5 dB
Channel separation 1 kHz	: 70 dB

Band level controls	: +12 dB~-12 dB (7 elements continuously variable per channel)
Center frequency	: 63 Hz, 160 Hz, 400 Hz, 1 kHz, 2.5 kHz, 6.3 kHz, 16 kHz

GENERAL

Power supply	: AC 50 Hz/60 Hz, 240 V (For United Kingdom and Australia) AC 50 Hz/60 Hz, 220 V (For continental Europe) AC 50 Hz/60 Hz, 110 V/120V/220V/240V (For other areas)
Power consumption	: 18 W
Dimensions (H \times W \times D)	: 86 \times 430 \times 234 mm. (3-3/8" \times 16-15/16" \times 9-7/32")
Weight	: 2.8 kg (6.2 lb)

Specifications are subject to change without notice for further improvement.

Technics

Panasonic Tokyo
Matsushita Electric Industrial Co., Ltd.
1-2, 1-chome, Shiba-koen, Minato-ku, Tokyo 105 Japan

Matsushita Electric Trading Co., Ltd.
P.O. Box 288, Central Osaka Japan

TECHNISCHE DATEN

(DIN 45 500)

Frequenzgang (mittelstellung)	: 5 Hz~100 kHz, -1 dB
Maximalausgangsspannung	: 8 V (1 kHz, THD 0,01%)
Nennausgangsspannung	: 1 V
Nennklirrfaktor	: 0,005% (20 Hz~20 kHz) 0,003% (1 kHz)
Eingangsspannung	: 1 V
Geräuschabstand	: 100 dB (110 dB, IHF, A)
Maximaleingangsspannung	: 8 V (1 kHz)
Eingangsimpedanz	: 33 kΩ
Verstärkung	: 0±1 dB
Kanalsymmetrie	
250 Hz~6300 Hz	: ±0,5 dB
Kanaltrennung 1kHz	: 70 dB

Frequenzgangregler	: +12 dB~-12 dB (7 Regler, stufenlos verstellbar)
Mittelfrequenzen	: 63 Hz, 160 Hz, 400 Hz, 1 kHz, 2,5 kHz, 6,3 kHz, 16 kHz

ALLGEMEINE DATEN

Stromversorgung	: Wechselstrom 50 Hz/60 Hz, 220 V (Für Kontinentaleuropa) Wechselstrom 50 Hz/60 Hz, 110 V/120 V/220 V/240 V (Für andere Länder)
Leistungsaufnahme	: 18 W
Abmessungen (H×B×T)	: 86×430×234 mm (3 ³ / ₈ "×16 ¹⁵ / ₁₆ "×9 ⁷ / ₃₂ "
Gewicht	: 2,8 kg (6,2 lb.)

Spezifikationen können infolge von Verbesserungen ohne Ankündigung geändert werden.

CARACTERISTIQUES

(DIN 45 500)

Réponse de fréquence (position centrale)	: 5 Hz~100 kHz, -1 dB
Tension de sortie maximale	: 8 V (1 kHz, THD 0,01%)
Tension de sortie nominale	: 1 V
Distorsion harmonique totale	: 0,005% (20 Hz~20 kHz) 0,003% (1 kHz)
Sensibilité d'entrée	: 1 V
Signal/Bruit	: 100 dB (110 dB, IHF, A)
Tension d'entrée maximale	: 8 V (1 kHz)
Impédance d'entrée	: 33 kΩ
Gain	: 0±1 dB
Équilibrage de canal	
250 Hz~6300 Hz	: ±0,5 dB
Séparation de canal 1 kHz	: 70 dB

Commandes de niveau de gamme

: +12 dB~-12 dB
(7 éléments, continuellement variables)

Fréquences charnières : 63 Hz, 160 Hz, 400 Hz, 1 kHz,
2,5 kHz, 6,3 kHz, 16 kHz

GENERALITES

Alimentation	: CA 50 Hz/60 Hz, 220 V (Pour l'Europe) CA 50 Hz/60 Hz, 110V/120V/220V/240V (Autres)
Consommation	: 18 W
Dimensions (h×l×pr) mm	: 86×430×234 mm (3-3/8"×16-15/16"×9-7/32")
Poids	: 2,8 kg (6,2 lb)

Sujet à changement sans préavis.

ESPECIFICACIONES

(DIN 45 500)

Respuesta de frecuencia (posición central)	: 5 Hz~100 kHz, -1 dB
Tensión de salida máxima	: 8 V (1 kHz, THD 0,01%)
Tensión de salida de régimen	: 1 V
Distorsión armónica total nominal	: 0,005% (20 Hz~20 kHz) 0,003% (1 kHz)
Sensibilidad de entrada	: 1 V
Relación de señal ruido	: 100 dB (110 dB, IHF, A)
Tensión de entrada máxima	: 8 V (1 kHz)
Impedancia de entrada	: 33 kΩ
Ganancia	: 0±1 dB
Equilibrio de canales	
250 Hz~6300 Hz	: ±0,5 dB
Separación de canales 1 kHz	: 70 dB

Controles de nivel de banda

: +12 dB~-12 dB
(7 elementos, continuamente variables)

Frecuencia central : 63 Hz, 160 Hz, 400 Hz, 1 kHz,
2,5 kHz, 6,3 kHz, 16 kHz

EN GENERAL

Alimentación de corriente	: CA 50 Hz/60 Hz, 220 V (Para Europa continental) CA 50 Hz/60 Hz, 110V/120V/220V/240V (Para otros países)
Consumo de corriente	: 18 W
Dimensiones (alto×ancho×prof.)	: 86×430×234 mm (3-3/8"×16-15/16"×9-7/32")
Peso	: 2,8 kg (6,2 lb)

Estas especificaciones están sujetas a cualquier cambio sin previo aviso.

LOCATION OF CONTROLS

- Rear panel

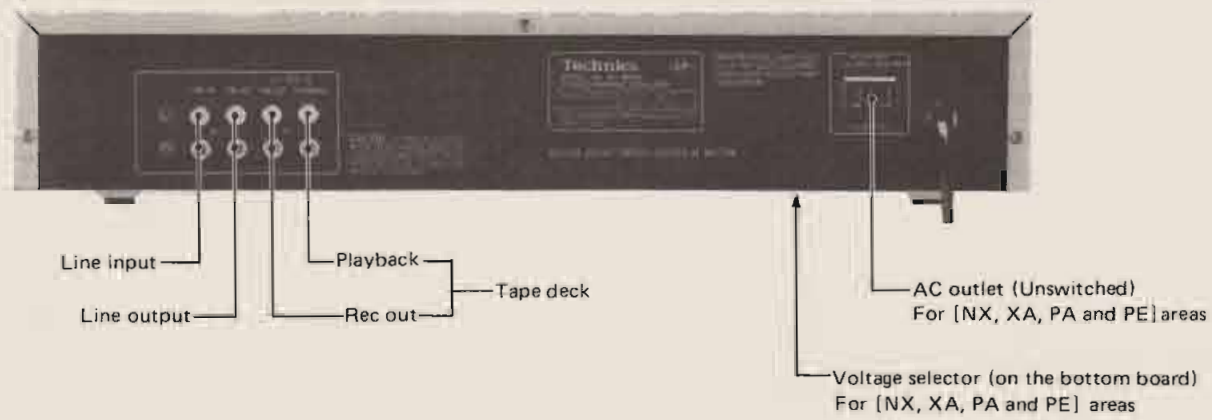

CHANGE IN SCHEMATIC DIAGRAM

- Power source circuit

For the U.S.A. [M]

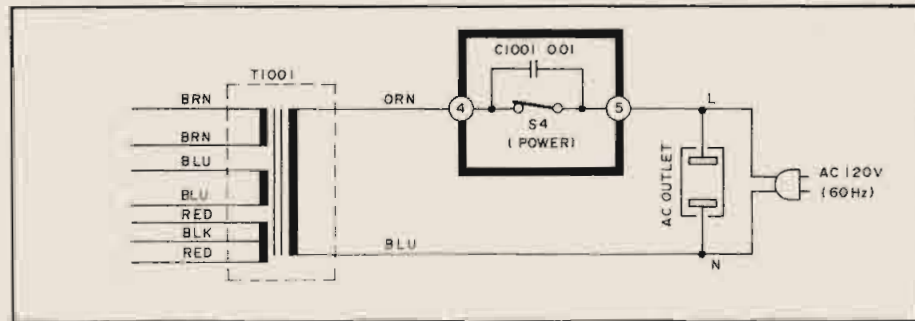

For continental Europe, United Kingdom [EK] and Australia [XL]

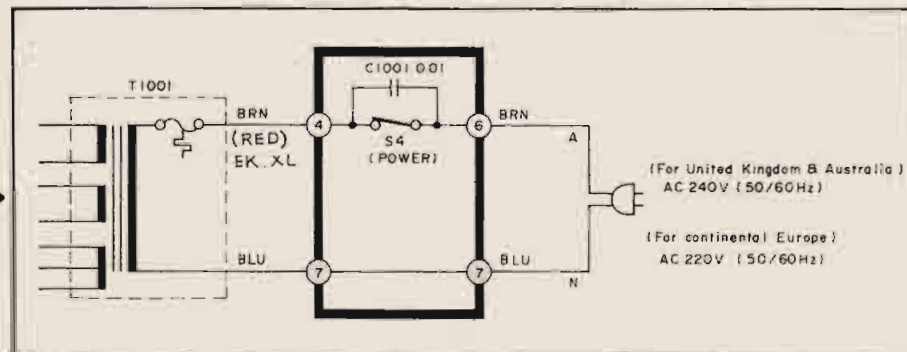

For other areas [XA, PA, PE & NX]

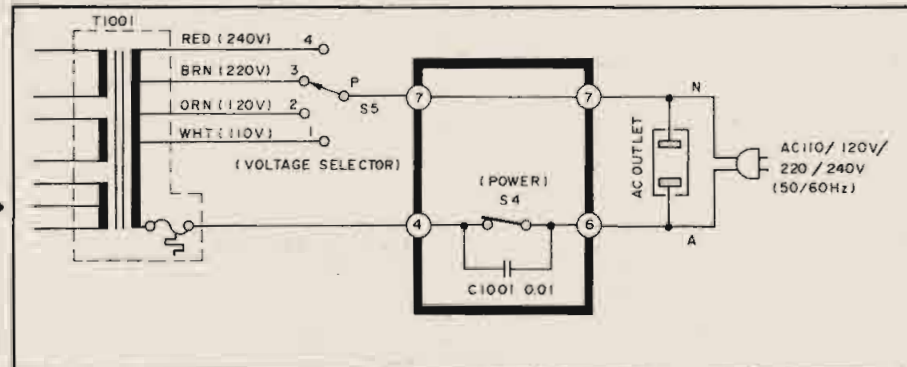

PRINTED CIRCUIT BOARDS AND WIRING CONNECTION DIAGRAM

- Power source circuit

For continental Europe, United Kingdom [EK] and Australia [XL]

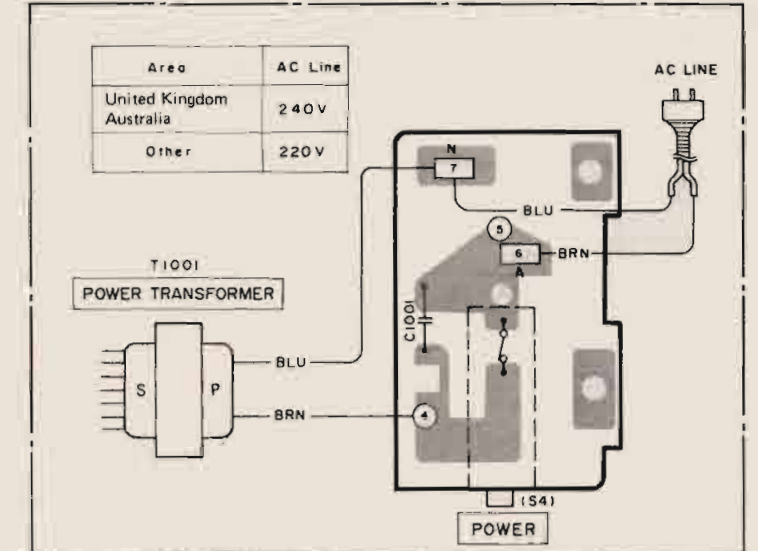

For other areas [XA, PA, PE & NX]

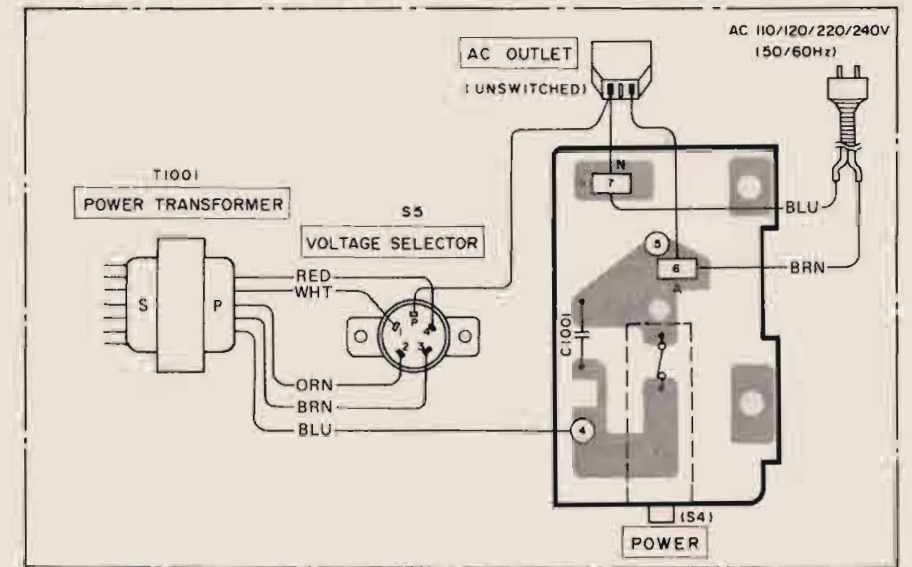

CHANGE IN REPLACEMENT PARTS LIST

- Note: 1. Mentioned in this parts list are only those changed in Model No. SH-8044 for destination [M] area.
 2. (K) - marked parts are used for black only, while (O) - marked parts are for silver type only.
 3. Part other than (K) - and (O) - marked are used for both black and silver type.
 4. Bracketed indications in Ref. No. Columns specify the area. Parts without these indications can be used for all areas.

Ref. No.	Change of Part No.		Description	
	SH-8044 [M]	SH-8044 Europe, Other	Color	Area
SWITCH				
S5	Addition	ESE3787		[NX, XA, PA & PE] only Voltage Selector
TRANSFORMER				
T1001	SLTK5J24-W	SLTK5J25-W		[NX, XA, PA & PE]
		SLTK5J27-W		[XL & EK]
		SLTK5J26-W		[Other] area
RESISTORS				
R73 ~ R76	Addition	ERD10TJ102		[EGA] only 1kΩ, 1/8W, Carbon

REPLACEMENT PARTS LIST

- Notes:** 1. Part numbers are indicated on most mechanical parts. Please use this part number for parts order.
 2. Important safety notice: Components identified by Δ mark have special characteristics important for safety. When replacing any of these components, use only manufacturer's specified parts.
 3. \otimes -marked parts are used for black only, while \circ -marked parts are for silver type only.
 4. Part other than \otimes - and \circ -marked are used for both black and silver type.
 5. Bracketed indications in Ref. No. columns specify the area. Parts without these indications can be used for all areas.
 6. The "S" mark is service standard parts and may differ from production parts.
 7. The parenthesized numbers in the column of description stand for the quantity per set.

Ref. No.	Change of Part No.		Description		
	SH-8044 [M]	Color	SH-8044 Europe, Other	Color	Area
CAPACITORS					
C67 ~ C70	Addition		ECCD1H151K		[EGA] only 150pF, 50V, Ceramic
C71, 72	Addition		ECKD1H331KB		[EGA] only 330pF, 50V, Ceramic
C73, 74	Addition		ECKD1H223ZF		[EGA] only 0.022 μ F, 50V, Ceramic
CABINET and CHASSIS PARTS					
5	SBWK22	\circ	SBWK22		Button, Volume (Use for both black and silver types)
	SBWK23	\otimes			
6	SGXK94		SGXK93		Cloth, Light Shielding
7	SGXK91-2	\circ	SGXK91-1	\circ	Sub Panel
	SGXK91	\otimes	SGXK91	\otimes	
16	RHR111		SHR129		[EK] only Bushing, AC Cord
			SHR127		[Other] area
17	SJS9221-1		SJS9221-1		[NX, XA, PA & PE] only Socket, AC Outlet
			Deletion		[Other]
18	RJA9YA		QFC1205M		[EK] AC Cord, Power Source
			QFC1208M		[XL]
			RJA52YA		[PA, PE]
			SJA138-3		[Other]
20	SGPKH8044M		SGPKH8044X		[NX, XA, PA & PE] Rear Panel, (w/Feet)
			SGPKH8044E		[E]
			SGPKH8044K		[EK]
			SGPKH8044L		[XL]
			SGPKH8044G		[Other]
SCREW					
N13	Addition		XTB3+8BFN		[NX, XA, PA & PE] only Voltage Selector M'tg.
ACCESSORIES					
A2	SQFK10071		SQFK10074		[EGA] Instruction Book
			SQFK10075		[Ei]
			SQFK10076		[PA, PE]
			SQFK10073		[Other]
A3	Addition		SJP9215		[PA, PE] only Plug Adaptor, AC (U \rightarrow B), (U \rightarrow C)
A4	Addition		SJP5213-1		[XA, NX] only Plug Adaptor, AC (C \rightarrow U)
PACKING PARTS					
P1	SPGK137		SPGK138	\circ	[EK] only Carton Box, Silver Type
			SPGK137	\circ	[Other] area
P1	SPGK140		SPGK142	\otimes	[EK] Carton Box, Black Type
			SPGK139	\otimes	[EF]
			SPGK140	\otimes	[Other] area

Ref. No.	Part No.	Part Name & Description	Ref. No.	Part No.	Part Name & Description	Ref. No.	Part No.	Part Name & Description
INTEGRATED CIRCUITS			DIODES			COMPONENT COMBINATIONS		
IC1, 2, 502~506	SVITA75559S	Control Amp., Buffer & Spectrum Analyzer B.P.F.	D5	MA167	Rectifier	Z4	RGSD8X472X	4.7k Ω (\times 8)
IC501	AN78N12	12V Regulator	D6~9, 501~508	SVD1SS119-04	Switching & Detector	Z5	RGHD12X562K	1/4W, 5.6k Ω (\times 12)
IC507	M54832AP	Channel Selector	D101~114	LN251RCPP	LED, Volume	SWITCHES		
IC508	SVIHA12010	FL Driver	D509, 510	SVD1SR35200	Rectifier	S1, 2	SSHK47	Rec mode, Tape Monitor
TRANSISTORS			D511	20A90	Bias	S3	SSHK46	Equalization
Q1	2SD1406-Y	Regulator	D512	MA4120H	12V Zener	S4	SSH1071	Power source
Q2	2SB1015-Y	Regulator	D514	LN81CPH	LED, Power	S5[NX, XA, PA, PE]	ESE3787	Voltage Selector
Q3	2SC1815-G	Muting	VARIABLE RESISTORS			TRANSFORMER		
Q4, 509, 511~518	2SA1015Y	Muting, Buffer & Inverter	VR1~14	EVAJN3J15G25	Band Level Control, 200k Ω (G)	T1001(NX, XA, PA, PE)	SLTK5J25-W	Power Transformer
Q5, 6, 510	2SC2878A-T	Muting	FLUORESCENT DISPLAY TUBE			T1001(XL, EK)	SLTK5J27-W	Power Transformer
Q501~508	2SA1246T-A	Sampling Gate	FL	SADBG239ZK	Display	T1001[other]	SLTK5J26-W	Power Transformer
Q519~530	UN4115	Buffer	COMPONENT COMBINATIONS					
DIODES			Z1	RGSD7X104K	100k Ω (\times 7)			
D1, 2	MA4150H	15V Zener	Z2	RGSD8X104K	100k Ω (\times 8)			
D3	SVD1B4B42	Rectifier	Z3	PJB7XC331M	330pF(\times 7)			
CABINET and CHASSIS PARTS			CABINET and CHASSIS PARTS			SCREWS and WASHERS		
1	SGU419-3	Transparent Plate (1)	18(PA, PE)	RJA52YA	AC Cord, (1)	N3	XTB3+8BFN	Tapping, \oplus 3 \times 8 (3)
1	SGU419-1	Transparent Plate (1)	18[other]	SJA138-3	AC Cord, (1)	N3	XTB3+8BFZ	Tapping, \oplus 3 \times 8 (3)
2	SGXK92	Grille (1)	19	SJF3055-1N	Terminal Board, In/Out (1)	N4	XTB3+8BFN	Tapping, \oplus 3 \times 8 (2)
3	SDUK11	Filter (1)	20(NX, XA, PA, PE)	SGPKH8044X	Rear Panel, (W/Feet) (1)	N5	XTB3+6BFN	Tapping, \oplus 3 \times 6 (2)
4	SDUK12	Sheet, Front Panel (1)	20(E)	SGPKH8044E	Rear Panel, (W/Feet) (1)	N6	XTB3+8CFYR1	Tapping, \oplus 3 \times 8 (W/Detent) (2)
5	SBWK22	Button (1)	20(EK)	SGPKH8044K	Rear Panel, (W/Feet) (1)	N7	XSN3+8S	Screw, \oplus 3 \times 8 (1)
6	SGXK93	Cloth, Shielding (1)	20(XL)	SGPKH8044L	Rear Panel, (W/Feet) (1)	N7~1	XWA3B	Washer, Spring ϕ 3 (1)
7	SGXK91-1	Sub Panel (1)	20[other]	SGPKH8044G	Rear Panel, (W/Feet) (1)	N7-2	XWG3	Washer, ϕ 3 (1)
7	SGXK91	Sub Panel (1)	[20-1]	[SHS2481]	Foot (4)	N8	XTN3+6B	Tapping, \oplus 3 \times 6 (2)
8	SGWK280SA	Front Panel (1)	21	SJT783	Terminal Socket (2)	N8-1	XWG3	Washer, ϕ 3 (2)
8	SGWK280BA	Front Panel (1)	22	SJS5811	Socket (2)	N9	XTB3+10BFZ	Tapping, \oplus 3 \times 10 (2)
9	SHR9728	Holder, FL (2)	23	SJT3809	Connector (2)	N10	XWC3B	Stop Ring (2)
10	SBC666	Button, Power SW (1)	24	SJT5807	Connector (1)	N11	XTB3+8BFYR	Tapping, \oplus 3 \times 8 (3)
11	SUB81	Rod, Connection Power SW (1)	25	SJT3319	Connector, J7 (1)	N12	XTB3+8BFYR	Tapping, \oplus 3 \times 8 (3)
12	SBC315-4T	Button (3)	25	SJT3415	Connector, J8 (1)	N13	XTB3+8BFN	Tapping, \oplus 3 \times 8 (2)
13	SBZK33	Guide, Light (1)	25	SJT3511	Connector, J3 (1)	ACCESSORIES		
14	SKCK130S	Cabinet (1)	25	SJT3611	Connector, J11, 12 (1)	A1	SJPK2201	Cord, Pin-Pin (2)
14	SKCK130BB	Cabinet (1)	25	SJT3709	Connector, J1, 2, 10 (3)	A2[EGA]	SQFK10074	Instruction Book (1)
15	SMNK17	Cover, Power SW (1)	25	SJT3809	Connector, J9 (1)	A2[Ei]	SQFK10075	Instruction Book (1)
16(EK)	SHR129	Bushing, AC Cord (1)	26	SJS5339	Socket, J7 (1)	A2[PA, PE]	SQFK10076	Instruction Book (1)
16[other]	SHR127	Bushing, AC Cord (1)	26	SJS5433	Socket, J8 (1)	A2[other]	SQFK10073	Instruction Book (1)
17(NX, XA, PA, PE)	SJS9221-1	Socket, AC Outlet (1)	26	SJS5531	Socket, J3 (1)	A3(PA, PE)	SJP9215	Plug Adaptor (1)
18(EK)	QFC1205M	AC Cord, Power Source (1)	26	SJS5635	Socket, J11, 12 (2)	A4(XA, NX)	SJP5213-1	Plug Adaptor (1)
18(XL)	QFC1208M	AC Cord, Power Source (1)	26	SJS5719	Socket, J1, 2, 10 (3)	PACKING PARTS		
SCREWS and WASHERS			N1	XTB3+8BFZ	Tapping, \oplus 3 \times 8 (3)	P1(EK)	SPGK138	Carton Box (1)
N2	SNE2095-4	Cabinet (2)	N2	SNE2095-5	Cabinet (2)	P1[other]	SPGK137	Carton Box (1)
						P1(EK)	SPGK142	Carton Box (1)
						P1(EF)	SPGK139	Carton Box (1)
						P1[other]	SPGK140	Carton Box (1)
						P2	SPSK69	Pad, Front (1)
						P3	SPSK70	Pad, Rear (1)
						P4	SPSK74	Pad, Upper (1)
						P5	SPP719	Polyethylene Sheet (1)
						P5	SPP659	Polyethylene Sheet (1)

Service Manual

Equalizer

SH-8044

Stereo Graphic Equalizer
(With Spectrum Analyzer)

**Color**

(S)	Silver Type
(K)	Black Type

Color	Area
(S),(K)	[M] U.S.A.
(K)	[MC] Canada

- **System (U.S.A.)**
SC-7170E

SPECIFICATIONS

(IHF '78)

Center Frequency:	63Hz, 160Hz, 400Hz, 1kHz, 2.5kHz, 6.3kHz and 16kHz
Frequency Response: (center position)	5Hz ~ 100kHz (-1dB)
Band Level Controls:	+12dB ~ -12dB (7 continuously variable elements per channel)
Rated Total Harmonic Distortion:	0.005% (20Hz ~ 20kHz) 0.003% (1kHz)
Input Impedance:	33k ohms
Rated Output Voltage:	1V
Maximum Output Voltage:	8V (1kHz, THD 0.01%)
Input Sensitivity:	1V
Signal to Noise Ratio:	110dB (IHF'A)
Maximum Input Voltage:	8V (1kHz)
Gain:	0 ± 1dB

■ General

Power Supply:	120V AC, 60Hz
Power Consumption:	20 W
Weight:	6.2 lb (2.8 kg)
Dimensions:	Width: 16-15/16" (430mm) Height: 3-3/8" (86mm) Depth: 9-7/32" (234mm)

Specifications are subject to change without notice
for further improvement.

Weights and dimensions shown are approximate.

Technics

Matsushita Engineering and
Service Company
50 Meadowland Parkway,
Secaucus, New Jersey 07094

Panasonic Hawaii Inc.
91-238 Kauhū St. Ewa Beach
P.O. Box 774
Honolulu, Hawaii 96808-0774

Matsushita Electric
of Canada Limited
5770 Ambler Drive, Mississauga,
Ontario, L4W 2T3

Panasonic Sales Company,
Division of Matsushita Electric
of Puerto Rico, Inc.
Ave. 65 De Infantería, KM 9.7
Victoria Industrial Park
Carolina, Puerto Rico 00630

SAFETY PRECAUTION

1. Before servicing, unplug the power cord to prevent an electric shock.
2. When replacing parts, use only manufacturer's recommended components for safety.
3. Check the condition of the power cord. Replace if wear or damage is evident.
4. After servicing, be sure to restore the lead dress, insulation barriers, insulation papers, shields, etc.
5. Before returning the serviced equipment to the customer, be sure to make the following insulation resistance test to prevent the customer from being exposed to a shock hazard.

INSULATION RESISTANCE TEST

1. Unplug the power cord and short the two prongs of the plug with a jumper wire.
2. Turn on the power switch.
3. Measure the resistance value with ohmmeter between the jumpered AC plug and each exposed metal cabinet part, such as screwheads antenna, control shafts, handle brackets, etc. Equipment with antenna terminals should read between 3MΩ and 5.2MΩ to all exposed parts. (Fig. A) Equipment without antenna terminals should read approximately infinity to all exposed parts. (Fig. B)

Note: Some exposed parts may be isolated from the chassis by design. These will read infinity.

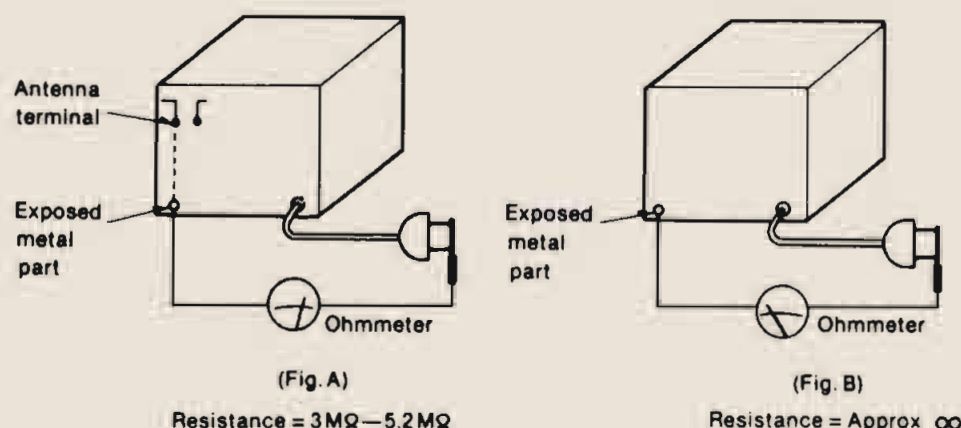

4. If the measurement is outside the specified limits, there is a possibility of a shock hazard. The equipment should be repaired and rechecked before it is returned to the customer.

CONTENTS

	Page		Page
SAFETY PRECAUTIONS	2	CIRCUIT BOARDS AND WIRING CONNECTION DIAGRAM	7, 8
LOCATION OF CONTROLS	2	BLOCK DIAGRAM	9
OPERATION	4	SCHEMATIC DIAGRAM	10 ~ 16
DISASSEMBLY INSTRUCTIONS	5	RESISTORS AND CAPACITORS	17
TECHNICAL INFORMATION	6	EXPLODED VIEW	18, 19
TERMINAL GUIDE OF TRANSISTORS, DIODES AND IC'S	6	REPLACEMENT PARTS LIST	20

LOCATION OF CONTROLS

Rear panel



Front panel

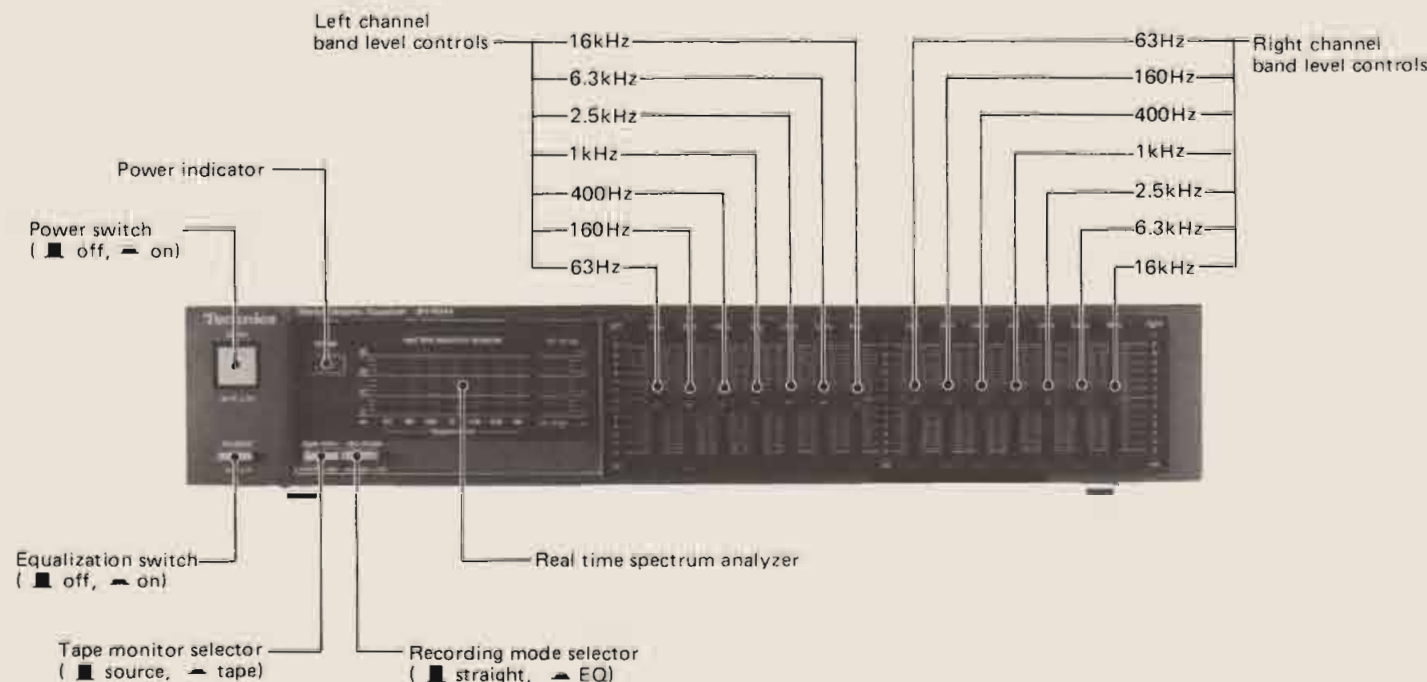



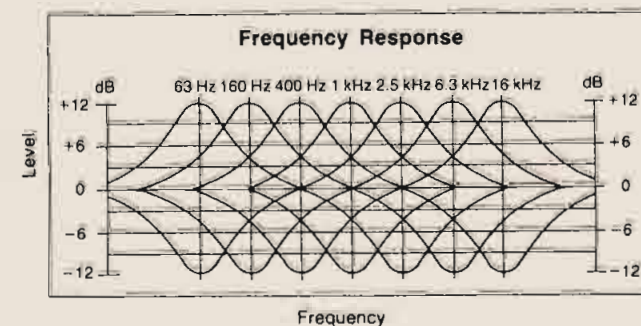



- Power switch**
 This switch is used to turn the power on and off.
- Power indicator**
 This indicator will illuminate when the power switch is turned on.
- Real time spectrum analyzer**
 - The same 7-band frequency divider as for the band level controls allows the levels of the frequency components of voices, music, etc., to be visually displayed.
 - The "full range" area on the right side displays the combined level of all of the frequency bands.
 (The indication is the combined value of the left and right input signals.)
- Band-level controls**
 These controls are used to adjust the 7 frequency levels. When these levers are moved in the "+ dB" direction, peak frequency characteristics are obtained. When they are moved in the "- dB" direction, dip frequency characteristics are obtained. These characteristics can be adjusted a maximum of ±12 dB.
- Equalization switch**
 This switch is used to turn the equalization circuitry on and off.
 - on (source):** Set to this position for equalizer correction.
 - off (tape):** Set to this position to turn off equalizer correction. By turning this switch on and off, the equalizer effect can also be checked. When this switch is in the "off" position, signals will still pass through the unit and be emitted, regardless of whether the power switch is in the "on" or "off" position.
- Tape-monitor selector**
 - source (source):** Set to this position to listen to the radio or a disc.
 - tape (tape):** Set to this position to listen to a tape deck.
- Recording mode selector**
 - straight (straight):** Set to this position to record without equalizer correction.
 - EQ (EQ):** Set to this position to make a tape recording of a radio broadcast or a disc while controlling the frequency response.**Note:** The equalization switch must be set to the "on" position and then the tape-monitor selector must be set to the "source" position, otherwise the frequency response cannot be controlled.
- Total frequency response**

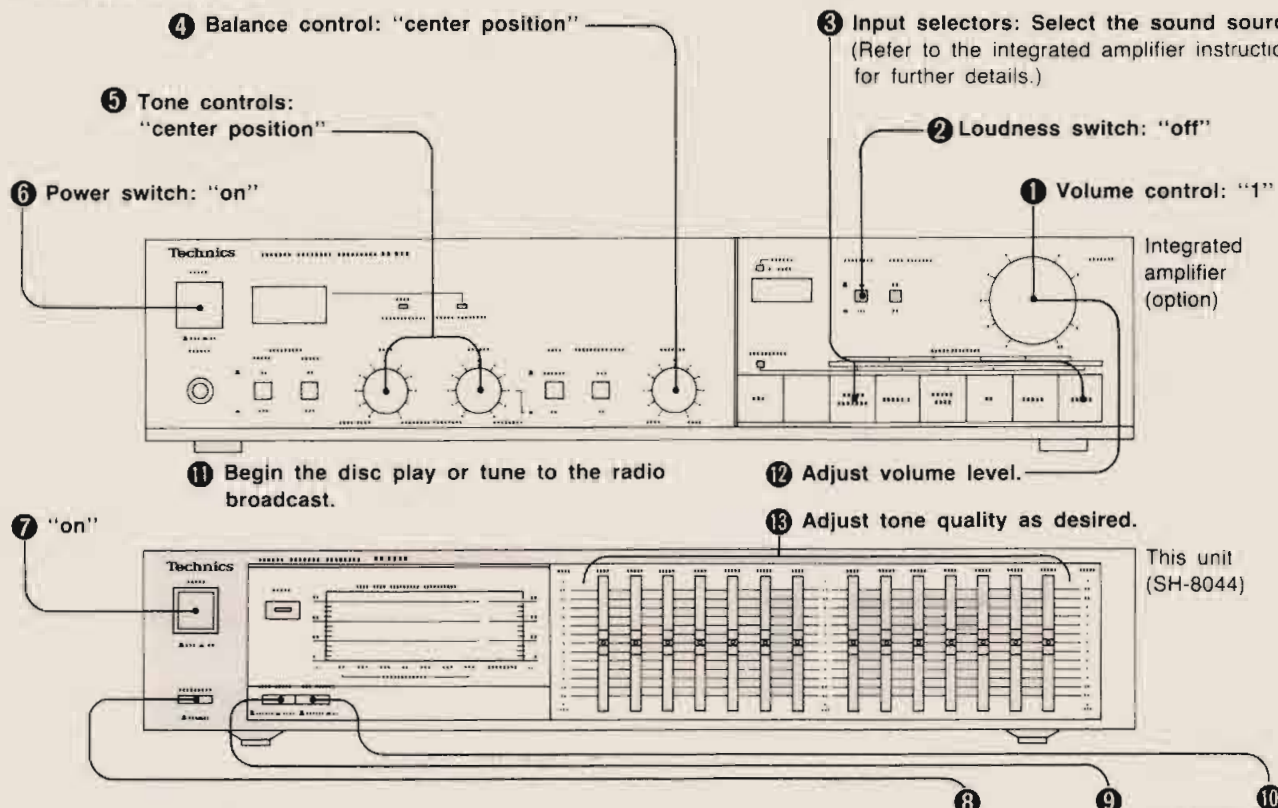

OPERATION

■ Connection of the input/output terminals (LINE OUT/LINE IN) of this unit to the external input/output terminals (EXT OUT/EXT IN) terminals of an integrated amplifier.



	equalizer	tape mon	rec mode
To listen to corrected sound of phono discs or radio.	"on" ()	"source" ()	Set to any position
To record corrected sound of phono discs or from radio.			"EQ" ()
To record the uncorrected sound of phono discs or from the radio.		"straight" ()	
To listen to corrected sound from a tape deck.		"tape" ()	Set to any position
Press the equalization switch (equalizer) in to the "off" () position to listen to uncorrected sound, or when recording.			

■ Connection of the input/output (LINE OUT/LINE IN) terminals of this unit to the tape input/output terminals (PLAYBACK/REC OUT) of an amplifier (amplifier operation changes from that shown in the figure above to that described below).

● If the amplifier has a recording mode selector and an input selector. (Make setting as shown in the figure.)

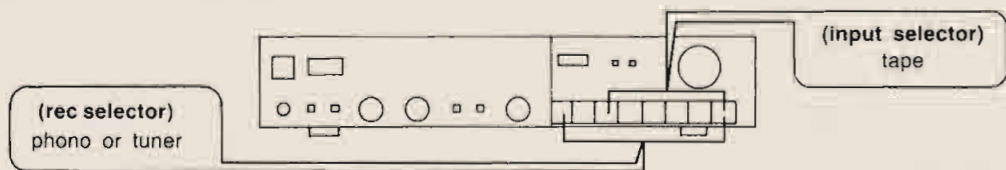

● If the amplifier has a tape-monitor selector and an input selector: (Make setting as shown in the figure.)

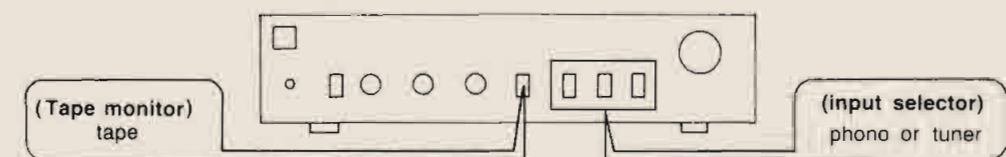

DISASSEMBLY INSTRUCTIONS

<p>Ref. No. 1</p> <p>Procedure 1</p> <ul style="list-style-type: none"> Remove the 5 screws. (1 ~ 5) 	<p>Ref. No. 2</p> <p>Procedure 1 → 2</p> <ul style="list-style-type: none"> Pull out the 4 connectors (J1 ~ J3 and J8) from EQ P.C.B. Pull out the 2 connectors (J7 and J12) from switch P.C.B. Remove the 2 screws. (6 ~ 7) Push the 2 tabs on the right and left sides of the front panel in the direction of arrow A. The tabs which project (at positions) from the front panel are engaged with the bottom board. Remove the front panel from chassis.
<p>Ref. No. 3</p> <p>Procedure 1 → 2 → 3</p> <ul style="list-style-type: none"> Move the 3 tabs in. (a). Remove the indicator panel. Remove the 14 knobs. Remove the 3 screws. (8 ~ 10) Move the 6 tabs to the side (b). Remove the P.C.B. 	<p>Ref. No. 4</p> <p>Procedure 1 → 2 → 4</p> <ul style="list-style-type: none"> Move the 4 tabs aside (c). Remove the band pass filter P.C.B.

TECHNICAL INFORMATION

• Band level control circuit

(for varying the center frequency by $\pm 12\text{dB}$)

The equalizer circuit of this unit is shown in Fig. 1. When the control volume (VR) is turned in the direction of $\rightarrow (+)$, NF level lowers with the connection shown in Fig. 2, causing the gain of operation amplifier to increase, then the "peak" appears. Contrarily, when VR is turned in the direction of $\leftarrow (-)$, the input impedance of operation amplifier becomes lowered with the connection shown in Fig. 3. Then the frequency level is "dip".

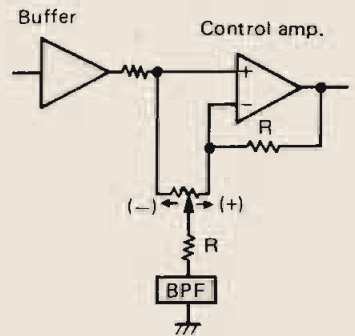

Fig. 1

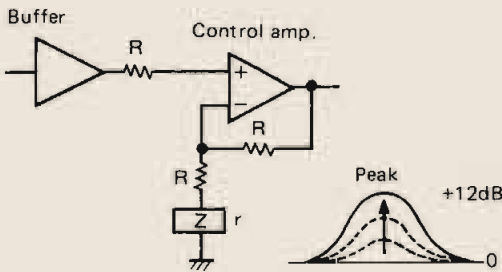

Fig. 2

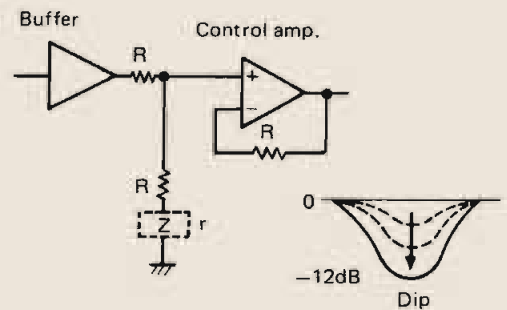

Fig. 3

TERMINAL GUIDE OF TRANSISTORS, DIODES AND IC'S

<p>SVITA75559S</p>	<p>AN78N12</p> <p>1. input 2. ground 3. output</p>	<p>M54832AP SVIHA12010</p>	<p>2SA1015, 2SC2878, 2SC1815, 2SA1246</p>
<p>UN4115</p>	<p>2SD1406, 2SB1015</p>	<p>MA4150, MA4120</p>	<p>SVD1B4B42</p>
<p>MA167, SVD1SS119-04 SVD1SR35200</p>	<p>LN251RCP</p>	<p>LN81CPH</p>	

CIRCUIT BOARDS AND WIRING CONNECTION DIAGRAM

BLOCK DIAGRAM

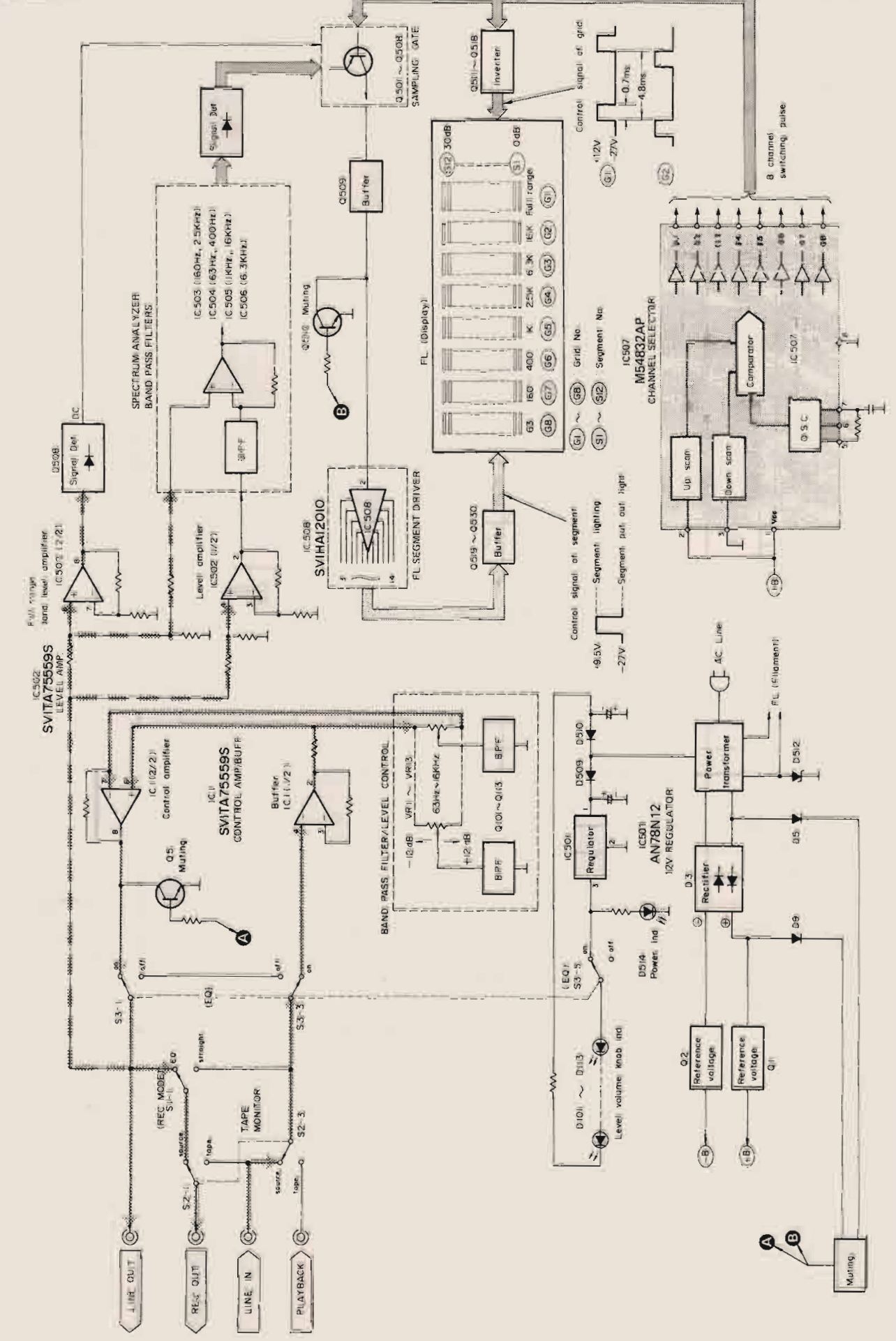
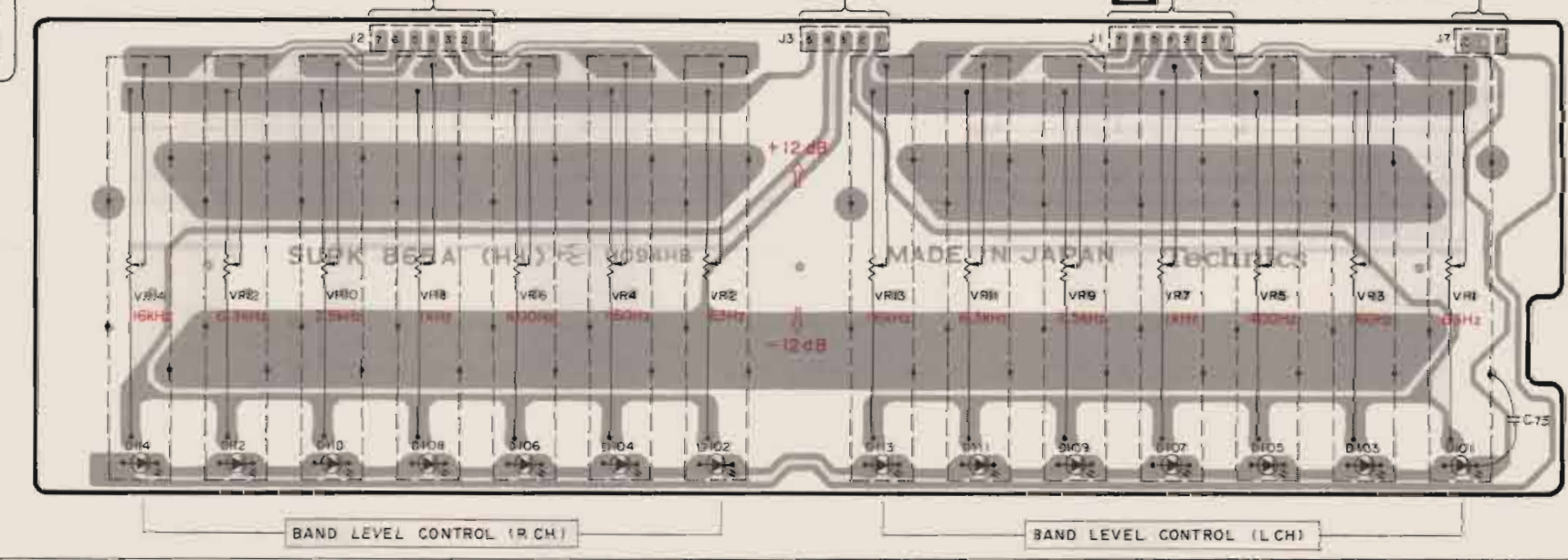
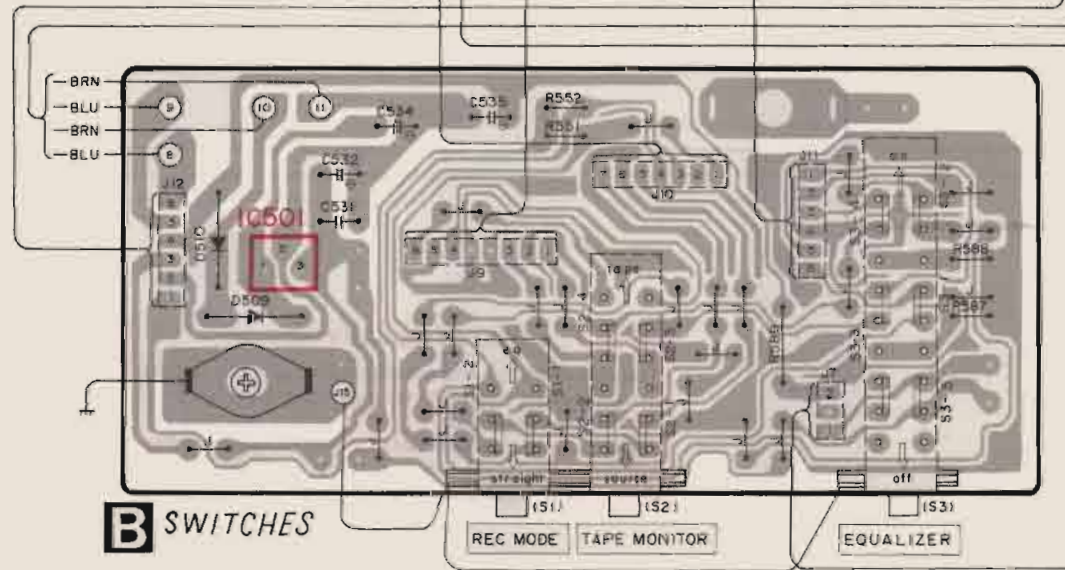
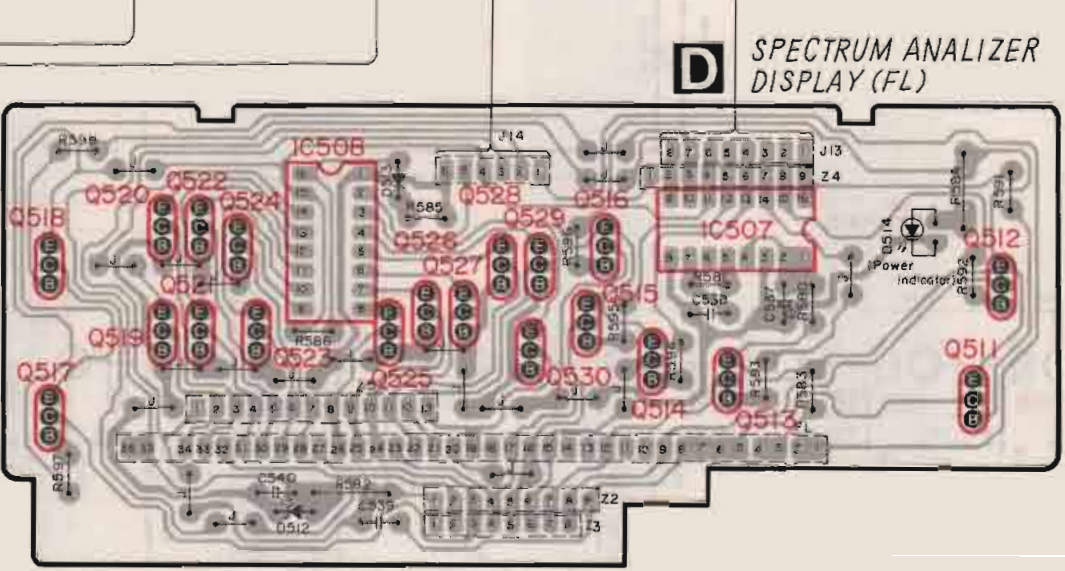
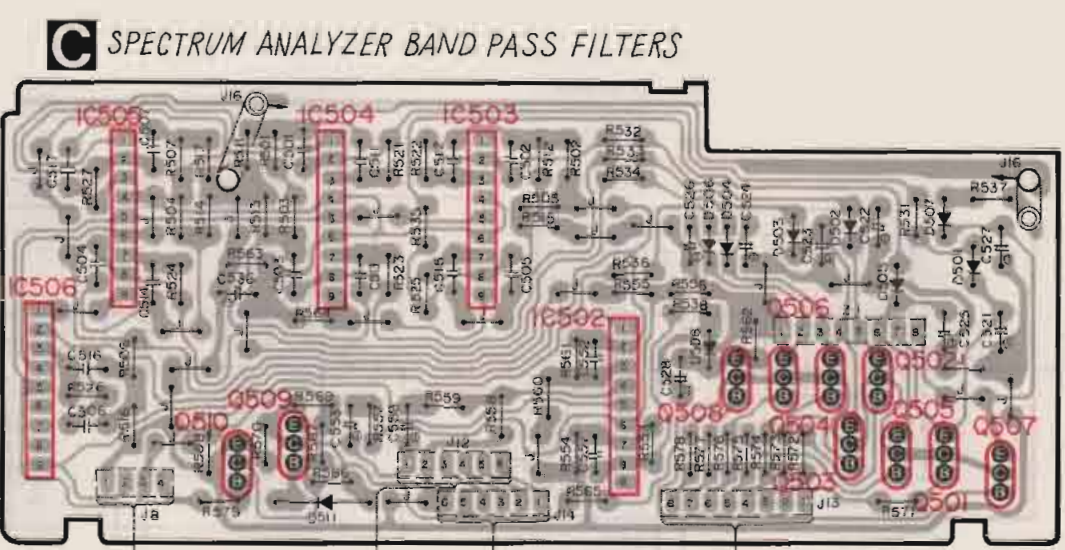
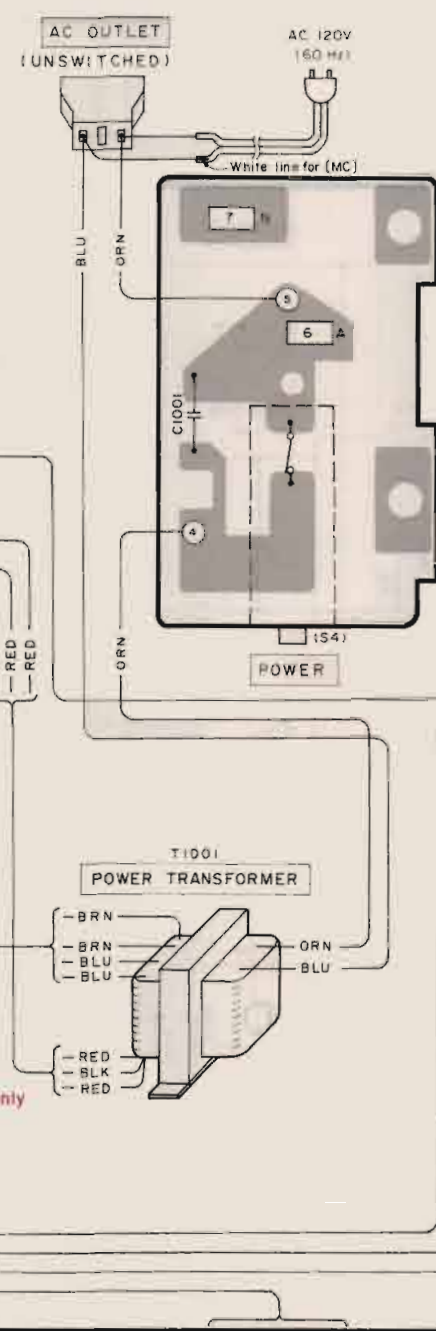
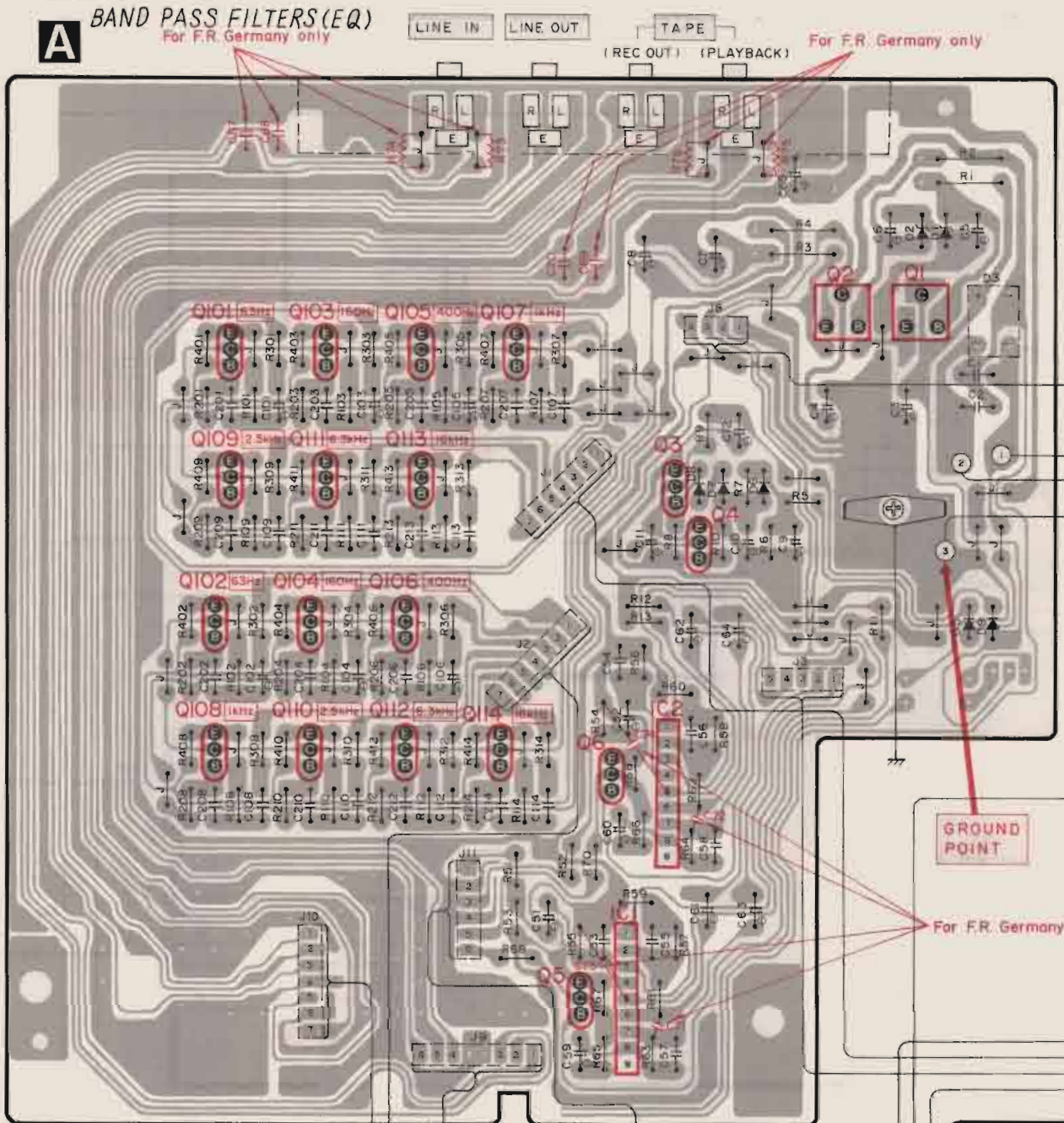

SCHEMATIC DIAGRAM

(This schematic diagram may be modified at any time with the development of new technology.)

- Spectrum analyzer (Frequency level display) & terminal voltage of grid and segment

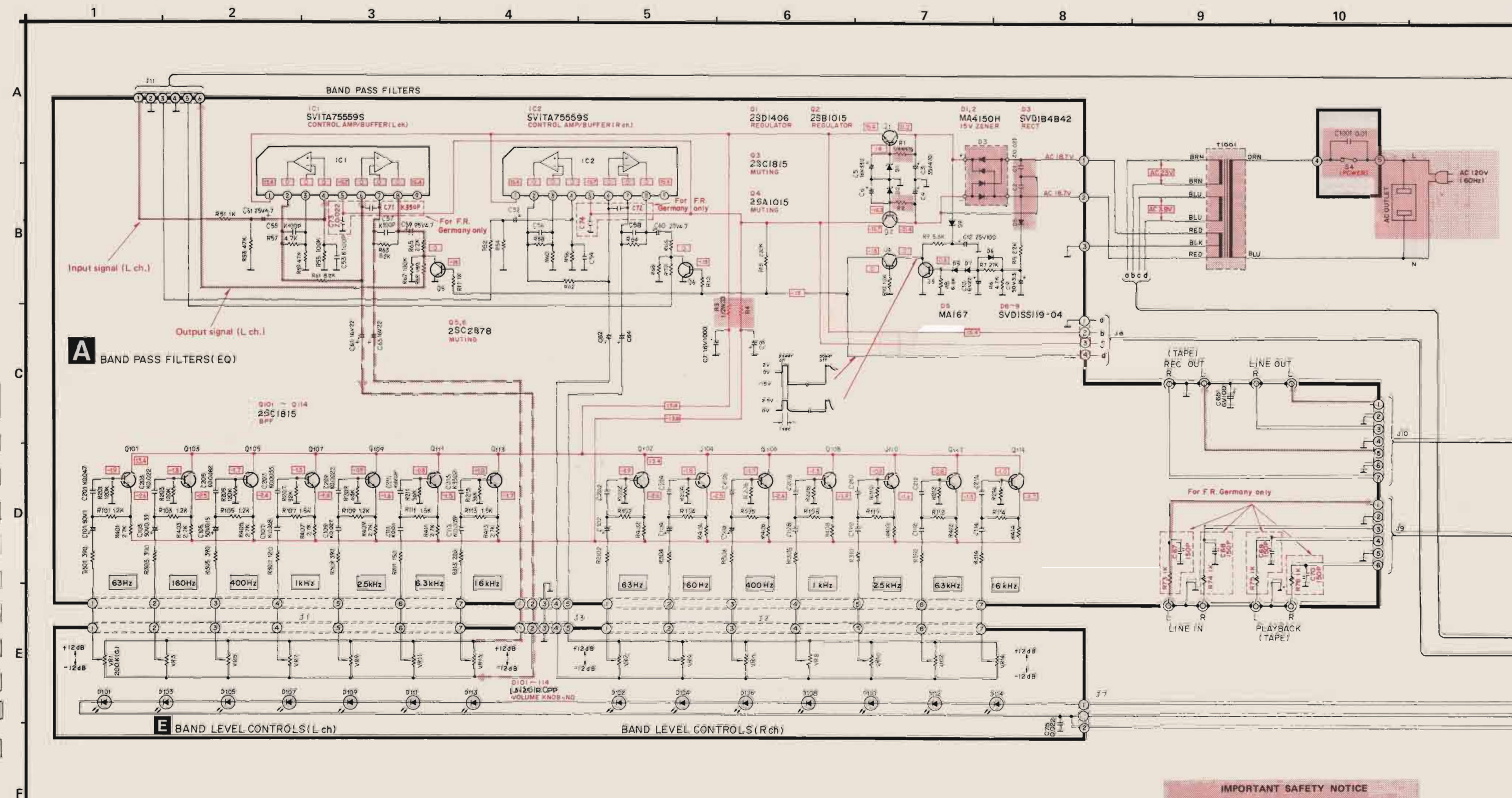
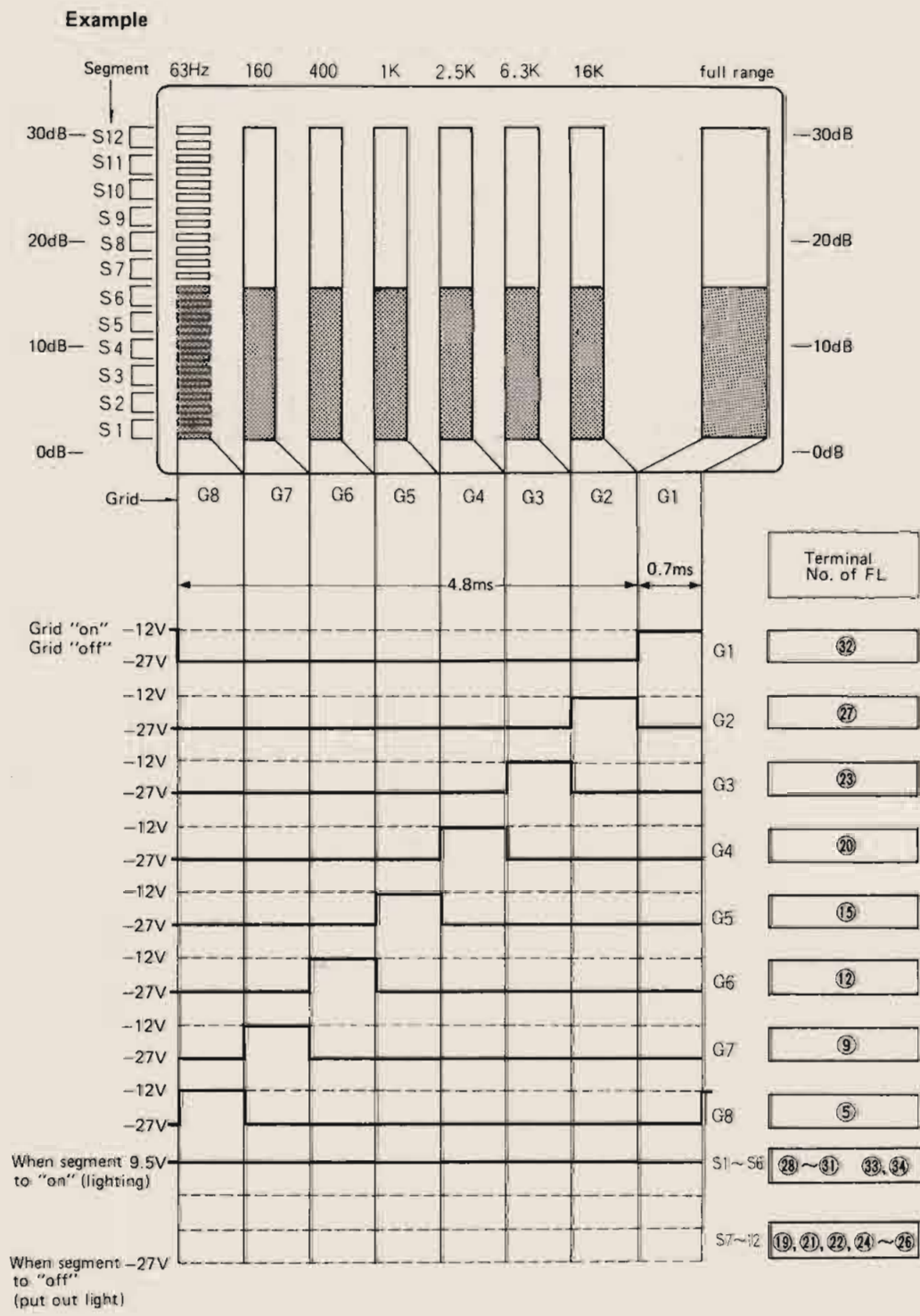

B SWITCHES

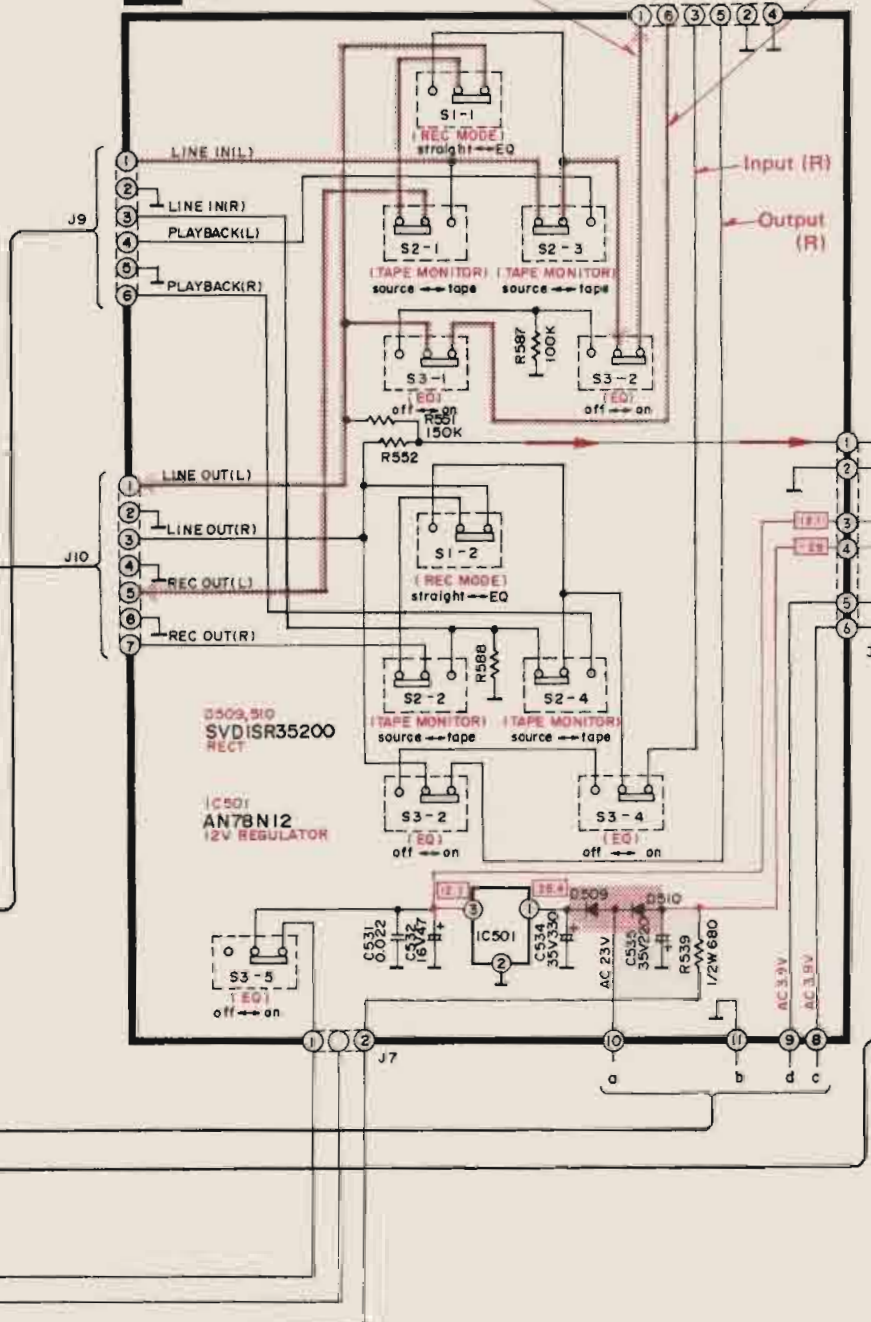

C SPECTRUM ANALYZER BAND PASS FILTERS

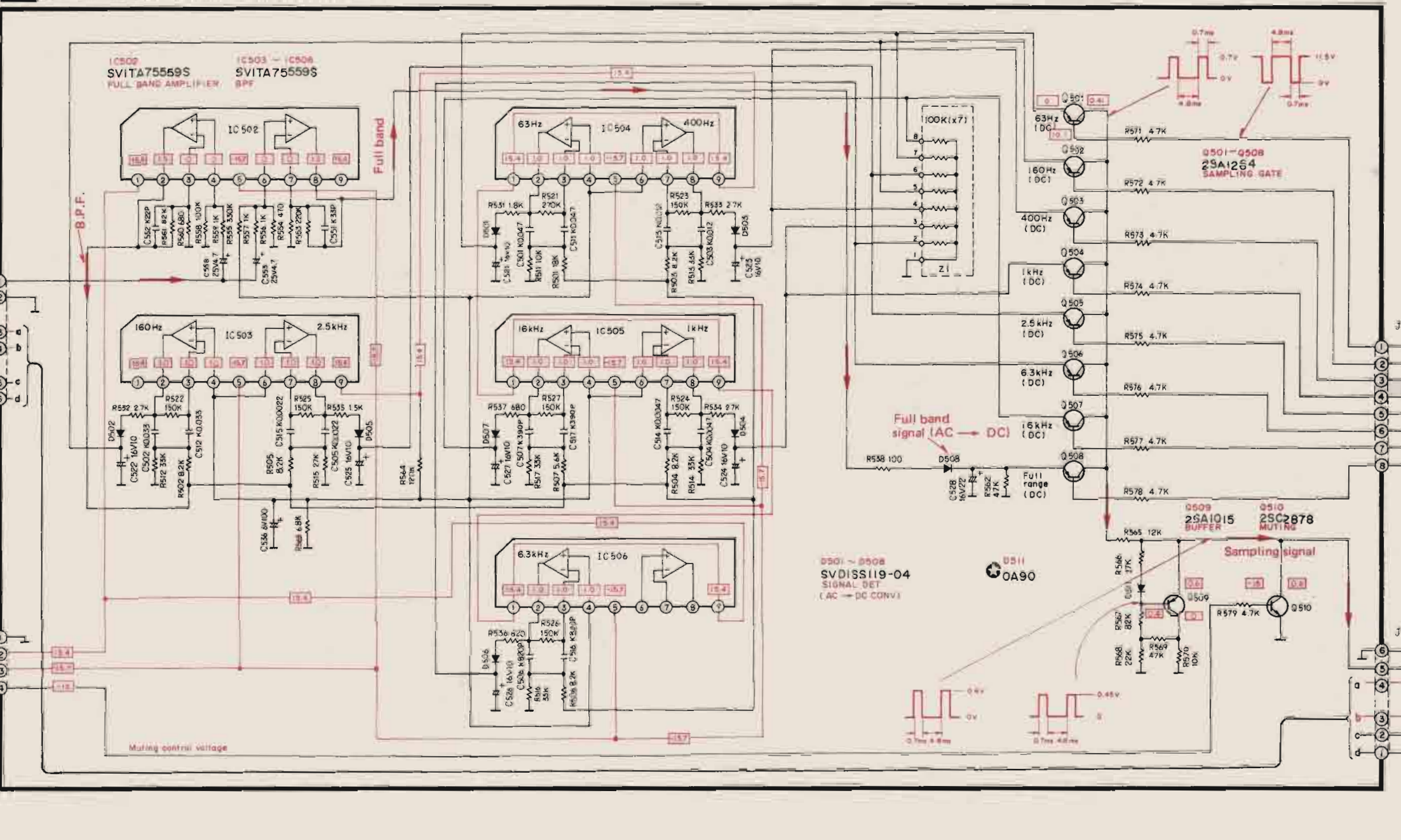

D SPECTRUM ANALYZER DISPLAY

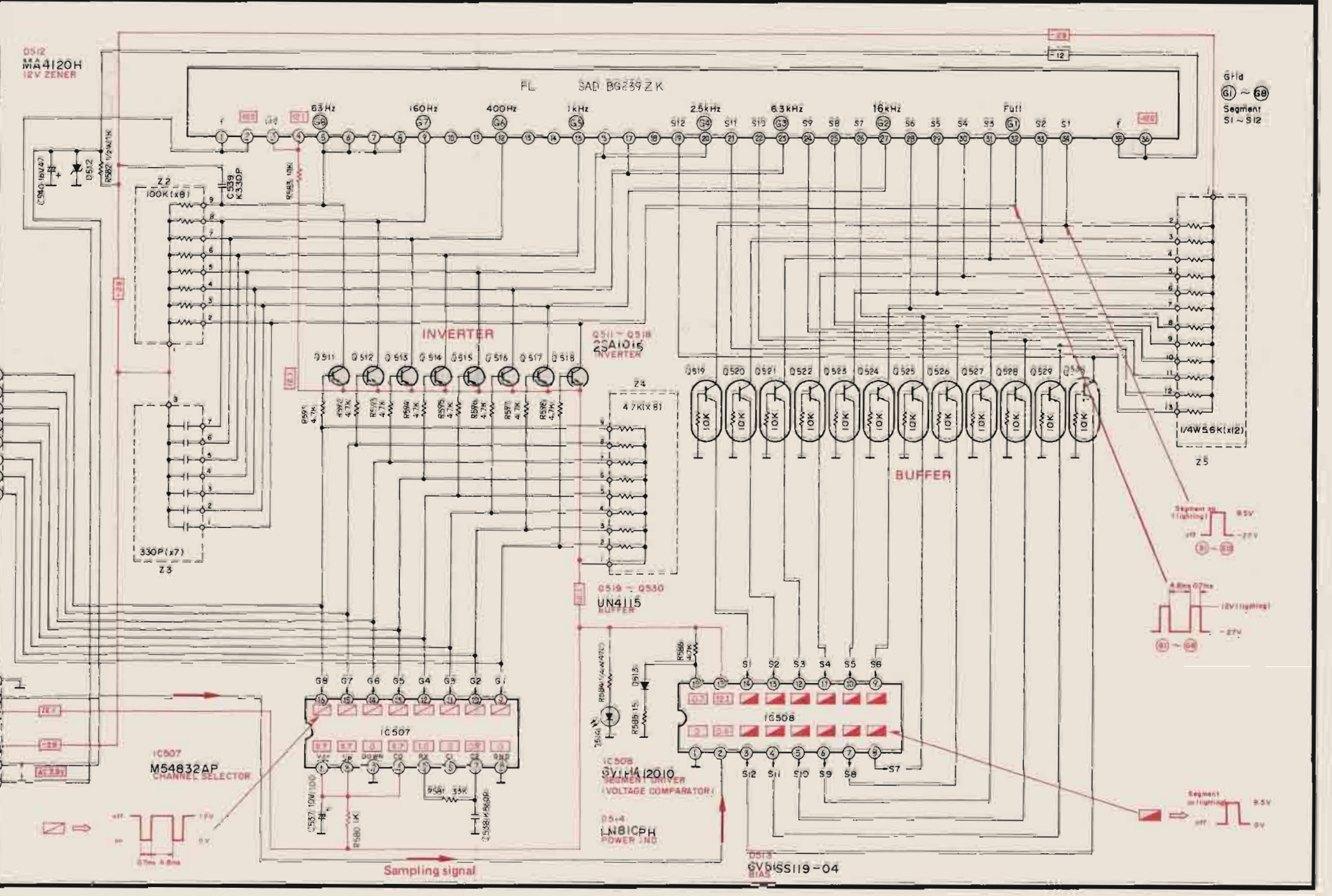

- Notes:**
- S1-1 ~ S1-2: Recording mode selector in "EQ" position, straight ↔ EQ
 - S2-1 ~ S2-4: Tape-monitor selector in "source" position, source ↔ tape
 - S3-1 ~ S3-5: Equalization switch in "on" position, on ↔ off
 - S4: Power source switch in "on" position, on ↔ off

- Indicated voltage values are standard values for the unit measured by the DC electronic circuit tester (high impedance) with the chassis taken standard.
- Positive and Negative voltage supply line.
- Signal line (Left channel)

- The part No. of transistors, IC and diodes mentioned in the schematic diagram stand for production part No. Regarding the part No. with ⊕ mark, the production part No. are different from the replacement part No. Therefore, when placing an order for replacement part, please use the part No. in the replacement part list.

RESISTORS & CAPACITORS

- Notes: 1. Part numbers are indicated on most mechanical parts. Please use this part number for parts orders. 2. Important safety notice: Components identified by a triangle mark have special characteristics important for safety. When replacing any of these components use only manufacturer's specified parts. 3. Bracketed indications in Ref. No. columns specify the area. Parts without these indications can be used for all areas. 4. The 'S' mark is service standard parts and may differ from production parts. 5. The unit of resistance is OHM (Ω). K = 1000Ω, M = 1000KΩ. 6. The unit of capacitance is MICROFARAD (μF), P = 10^-6 μF.

Numbering System of Resistor

Table with columns: ERD, Wattage, Shape, Tolerance, Value. Example: ERD: Carbon, 25: 1/4W, J: ±5%

Numbering System of Capacitor

Table with columns: ECKD, Voltage, Value, Tolerance, Peculiarity. Example: ECEA Type, Voltage, Peculiarity use, Value, Special use.

RESISTORS

Table listing Resistor Ref. No., Part No., Value, and corresponding values for other resistor types.

CAPACITORS

Table listing Capacitor Ref. No., Part No., Value, and corresponding values for other capacitor types.

EXPLODED VIEWS

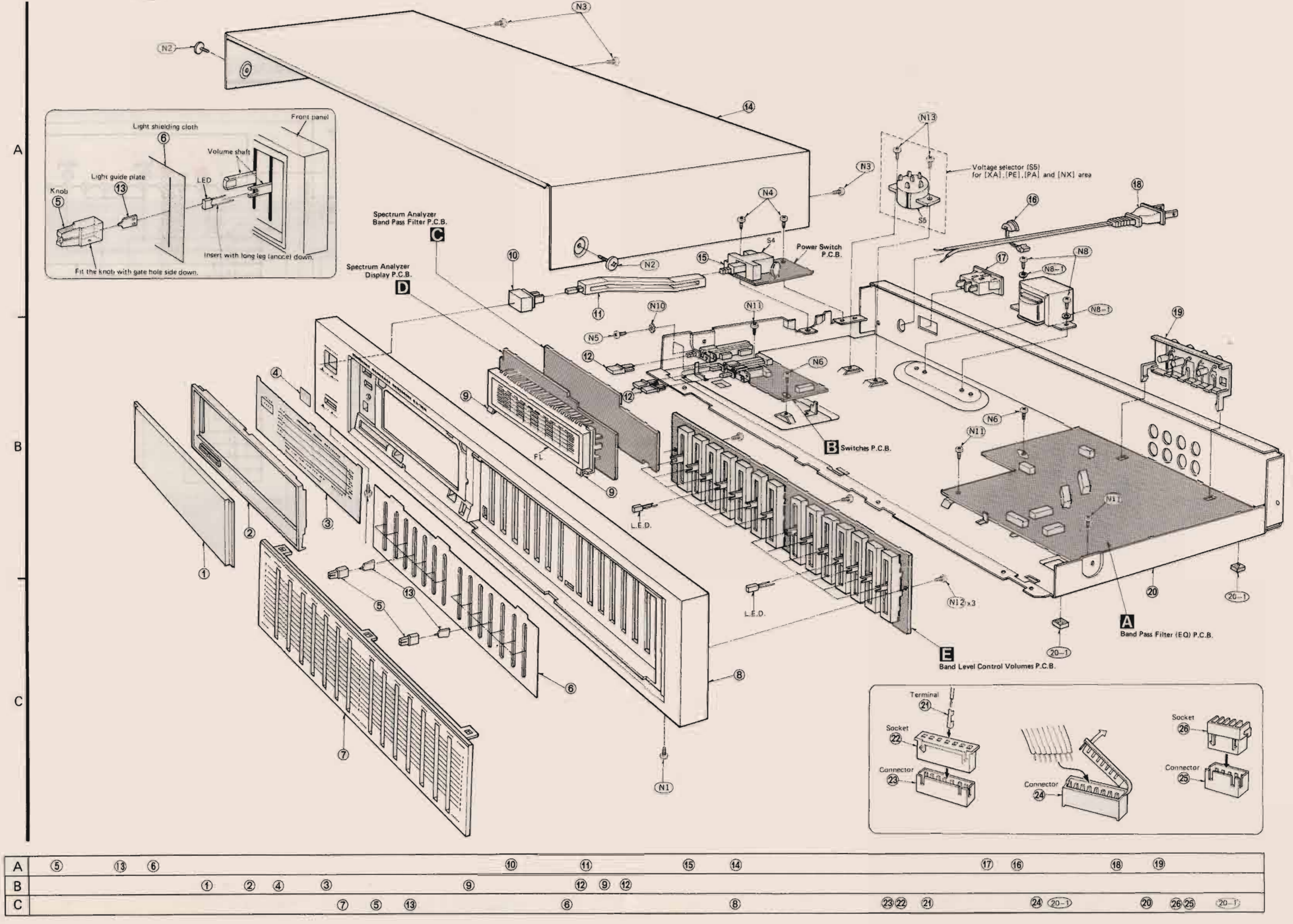

REPLACEMENT PARTS LIST

- Notes: 1. Part numbers are indicated on most mechanical parts. Please use this part number for parts order. 2. Important safety notice: Components identified by a triangle mark have special characteristics important for safety. When replacing any of these components, use only manufacturer's specified parts. 3. The 'S' mark is service standard parts and may differ from production parts. 4. The parenthesized numbers in the column of description stand for the quantity per set. 5. Bracketed indications in Ref. No. columns specify the area. Parts without these indications can be used for all areas. 6. O-marked parts are used for silver type only. K-marked parts are used for black type only. 7. Part other than O and K-marked are used for both black and silver types.

REPLACEMENT PARTS LIST table with columns: Ref. No., Part No., Part Name & Description. Sections include: INTEGRATED CIRCUITS, TRANSISTORS, DIODES, SWITCHES, TRANSFORMER, VARIABLE RESISTORS, FLUORESCENT DISPLAY TUBE.

REPLACEMENT PARTS LIST table with columns: Ref. No., Part No., Part Name & Description. Sections include: CABINET and CHASSIS PARTS, SCREWS and WASHERS, ACCESSORY, PACKING PARTS.

[M] only *SD-7170E(SC-7170E) SU-Z800, ST-Z400, RS-B50 SL-QL5, SH-8044 Outer Carton Box SPG5056 Spacer SPS4497