

Service Manual

Digital Surround Processor

Processor

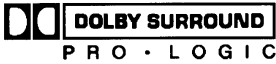

SH-AC500D

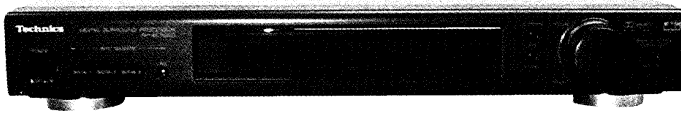
**Colour**

(K) Black Type

Area

Suffix for Model No.	Area	Colour
(E)	Europe	(K)
(EB)	Great Britain	

Manufactured under license from Dolby Laboratories. "DOLBY", "Pro Logic" and the double-D symbol are trademarks of Dolby Laboratories. Confidential Unpublished Works. © 1992-1997 Dolby Laboratories, Inc. All rights reserved.

DTS Inc. USP No. 5, 451, 942.

■ Specifications

■ AUDIO

Frequency response

FRONT L/R, CENTER, SURROUND L/R (LARGE)

20 Hz-20 kHz, ±1 dB

Outlet voltage/Impedance

2 V (at 0 dB)/1 kΩ

Input impedance

LINE

22 kΩ

COAXIAL

75 kΩ

Delay time

DOLBY DIGITAL

CENTER

0 – 5 ms

SURROUND L/R

0 – 15 ms

DOLBY PRO LOGIC

SURROUND L/R

15 – 30 ms

Total harmonic distortion

FRONT L/R (1 kHz, 0 dB, PCM)

0.007%

Dynamic range

96 dB

S/N (IHF-A)

100 dB

Load impedance

More than 10 kΩ

■ GENERAL

Power supply

AC 230 - 240 V, 50 Hz

Power consumption

18 W

Dimensions (W X H X D)

430 X 69.4 X 301.4 mm

Weight

2.6 kg

Notes :

Specifications are subject to change without notice.

Weight and dimensions are approximate.

⚠ WARNING

This service information is designed for experienced repair technicians only and is not designed for use by the general public. It does not contain warnings or cautions to advise non-technical individuals of potential dangers in attempting to service a product. Products powered by electricity should be serviced or repaired only by experienced professional technicians. Any attempt to service or repair the product or products dealt with in this service information by anyone else could result in serious injury or death.

Technics®

© 1999 Matsushita Electronics (S) Pte. Ltd.
All rights reserved. Unauthorized copying
and distribution is a violation of law.

■ Contents

	PAGE		PAGE
• ACCESSORIES	2	• TERMINAL FUNCTION OF IC'S	18
• CAUTIONS FOR AC MAINS LEAD	3	• TYPE ILLUSTRATION OF IC'S, TRANSISTORS AND DIODES	19
• FRONT PANEL CONTROLS	4	• WIRING CONNECTION DIAGRAM	20
• CONNECTIONS	5 ~ 7	• BLOCK DIAGRAM	21 ~ 23
• SPEAKER SETTING	8	• SCHEMATIC DIAGRAM	24 ~ 30
• SPEAKER OUTPUT ADJUSTMENTS	9 ~ 10	• PRINTED CIRCUIT BOARD	31 ~ 35
• DELAY TIME ADJUSTMENTS	11	• CABINET PARTS LOCATION	36
• ENJOYING SOUND IN A VARIETY OF REPRODUCTION MODES	12 ~ 13	• REPLACEMENT PARTS LIST	37 ~ 38
• OTHER FUNCTIONS	14	• RESISTORS & CAPACITORS	39 ~ 41
• REMOTE CONTROL QUICK REFERENCE	15	• PACKING MATERIALS & ACCESSORIES	42
• OPERATION CHECKS	16 ~ 17	• PACKAGING	42

■ Accessories

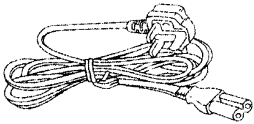
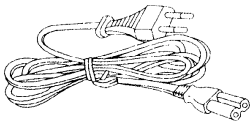
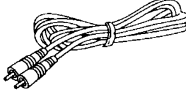
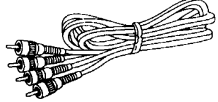
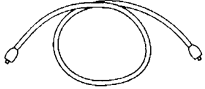
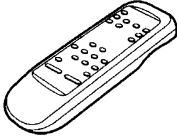
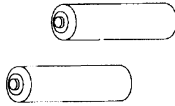
 <p>AC power supply cord for United Kingdom</p>	 <p>AC power supply cord for Others</p>	 <p>Monaural connection cables</p>	 <p>Stereo connection cables</p>
 <p>Optical-fiber cable</p>	 <p>Remote control unit</p>	 <p>Batteries</p>	

■ Caution for AC Mains Lead



(For "EB" area code model only.)

For your safety, please read the following text carefully.

This appliance is supplied with a moulded three pin mains plug for your safety and convenience.

A 5-ampere fuse is fitted in this plug.

Should the fuse need to be replaced please ensure that the replacement fuse has a rating of 5-ampere and that it is approved by ASTA or BSI to BS1362.

Check for the ASTA mark  or the BSI mark  on the body of the fuse.

If the plug contains a removable fuse cover you must ensure that it is refitted when the fuse is replaced.

If you lose the fuse cover, the plug must not be used until a replacement cover is obtained.

A replacement fuse cover can be purchased from your local dealer.

CAUTION !

IF THE FITTED MOULDED PLUG IS UNSUITABLE FOR THE SOCKET OUTLET IN YOUR HOME THEN THE FUSE SHOULD BE REMOVED AND THE PLUG CUT OFF AND DISPOSED OFF SAFELY.

THERE IS A DANGER OF SEVERE ELECTRICAL SHOCK IF THE CUT OFF PLUG IS INSERTED INTO ANY 13-AMPERE SOCKET.

If a new plug is to be fitted, please observe the wiring code as shown below.

If in any doubt please consult a qualified electrician.

IMPORTANT

The wires in this mains lead are coloured in accordance with the following code:

Blue: Neutral
Brown: Live

As these colours may not correspond with the coloured markings identifying the terminals in your plug, proceed as follows:

The wire which is coloured Blue must be connected to the terminal which is marked with the letter N or coloured Black or Blue.

The wire which is coloured Brown must be connected to the terminal which is marked with the letter L or coloured Brown or Red.

WARNING: DO NOT CONNECT EITHER WIRE TO THE EARTH TERMINAL WHICH IS MARKED WITH THE LETTER E, BY THE EARTH SYMBOL \perp OR COLOURED GREEN OR GREEN/YELLOW.

THIS PLUG IS NOT WATERPROOF—KEEP DRY.

Before use

Remove the connector cover.

How to replace the fuse

The location of the fuse differ according to the type of AC mains plug (figures A and B). Confirm the AC mains plug fitted and follow the instructions below.

Illustrations may differ from actual AC mains plug.

1. Open the fuse cover with a screwdriver.

Figure A

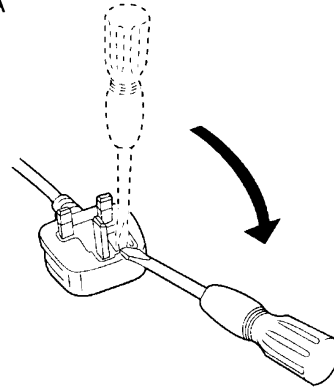
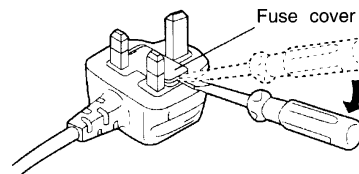

Figure B



2. Replace the fuse and close or attach the fuse cover.

Figure A

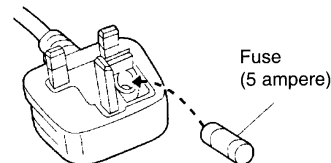
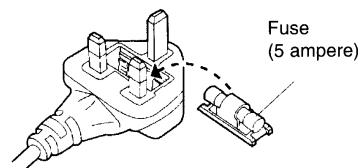
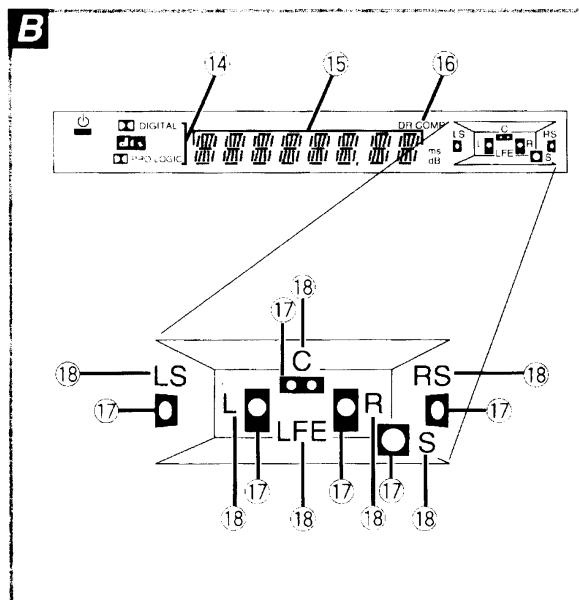
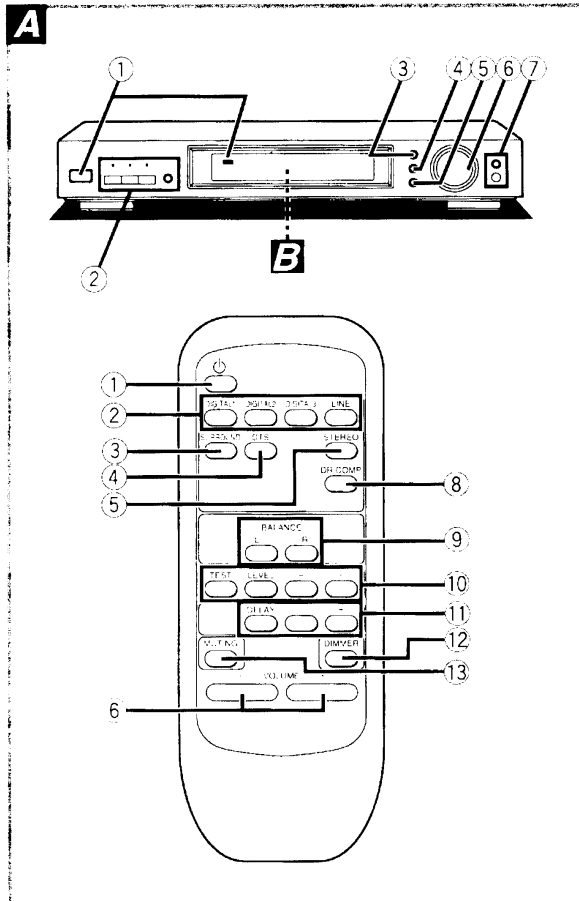

Figure B



Front panel controls



Control section A

① Unit on/off button () and remote standby indicator ()

Use this button to turn the unit on and off.

 (off): The unit is in standby mode.

 (on): The unit is on. The unit can be turned on and off with the remote control. When the unit is turned off with the remote control it is in remote standby and the indicator lights.

The unit is still using a small amount of power in the standby and remote standby conditions. Standby uses less power.

When the unit is connected to the AC mains lead, this indicator lights up in standby mode and goes out when the unit is turned on.

② Input select buttons/indicators

(DIGITAL 1, DIGITAL 2, DIGITAL 3, LINE)

③ Surround mode button (SURROUND)

④ Digital Theater Systems mode button (DTS)

⑤ Stereo mode button (STEREO)

⑥ Volume control (VOLUME)

Main unit only

⑦ Speaker setting buttons

(CHANNEL/SET, SELECTOR)

Remote control only

⑧ Dynamic range compression button (DR COMP)

⑨ Balance control (L, R)

⑩ Output level setting buttons

(TEST, LEVEL, -, +)

⑪ Delay time setting buttons (DELAY, -, +)

⑫ Dimmer button (DIMMER)

⑬ Muting button (MUTING)

Display section B

⑭ Surround format indicators

( DIGITAL,  DTS,  PRO LOGIC)

⑮ Display

⑯ Dynamic range compression indicator (DR COMP)

⑰ Speaker indicators

Light in accordance with the speaker setting, and each of the indicators corresponding with the speaker concerned flashes when;

- the type or presence of that speaker is set,
- the test signal is output from that speaker,
- the output level or delay time of that speaker is adjusted.

⑱ Signal format indicators (LS, C, RS, L, R, S, LFE)

These indicators light up to indicate the Dolby Digital or DTS input signal format.

LS: Surround speaker (left)

C: Center speaker

RS: Surround speaker (right)

L: Front speaker (left)

R: Front speaker (right)

"S" represents the mono surround and "LFE" (Low Frequency Effect) is a channel for the deep-bass effect in the low frequency range.

Connections

Before proceeding with the connections, ensure that the power to all the units has been turned off.
 Connect the AC power supply cord only after all other cables and cords are connected.

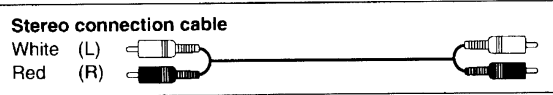

Connection to a receiver or amplifier

Connection to a receiver (or amplifier) with 6 channel discrete input terminals

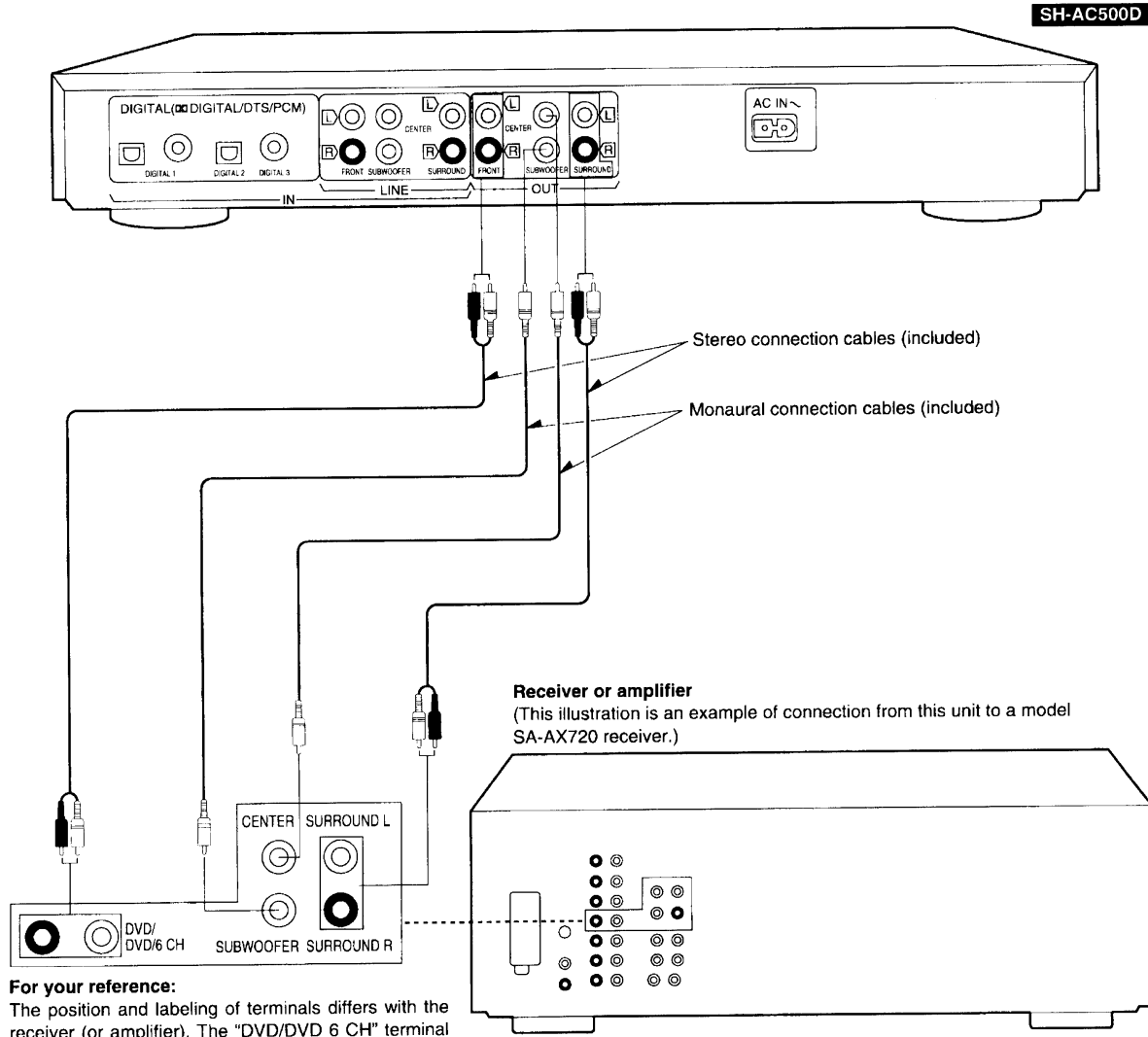

For your reference:
 The position and labeling of terminals differs with the receiver (or amplifier). The "DVD/DVD 6 CH" terminal in the above illustration, for example, is often labeled as "FRONT (L, R)."

Connections for outputting the 6 channel signals through 3 power amplifiers

This illustration is an example of connection from this unit to a stereo control amplifier of model SU-C1000 and three stereo power amplifiers of model SE-A1000.

SH-AC500D

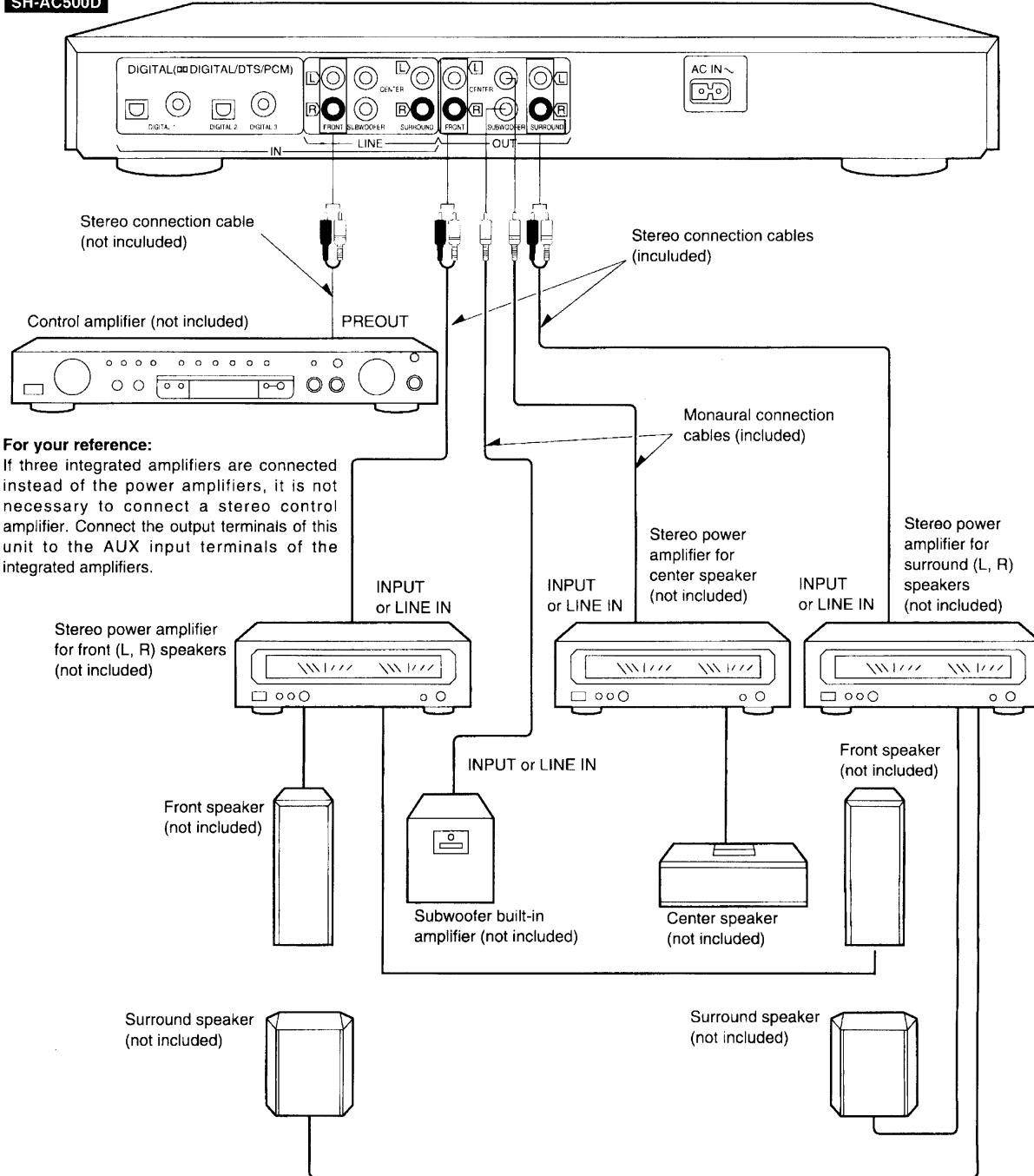

For your reference:

If three integrated amplifiers are connected instead of the power amplifiers, it is not necessary to connect a stereo control amplifier. Connect the output terminals of this unit to the AUX input terminals of the integrated amplifiers.

Connections to audio-visual equipment and the AC power cord

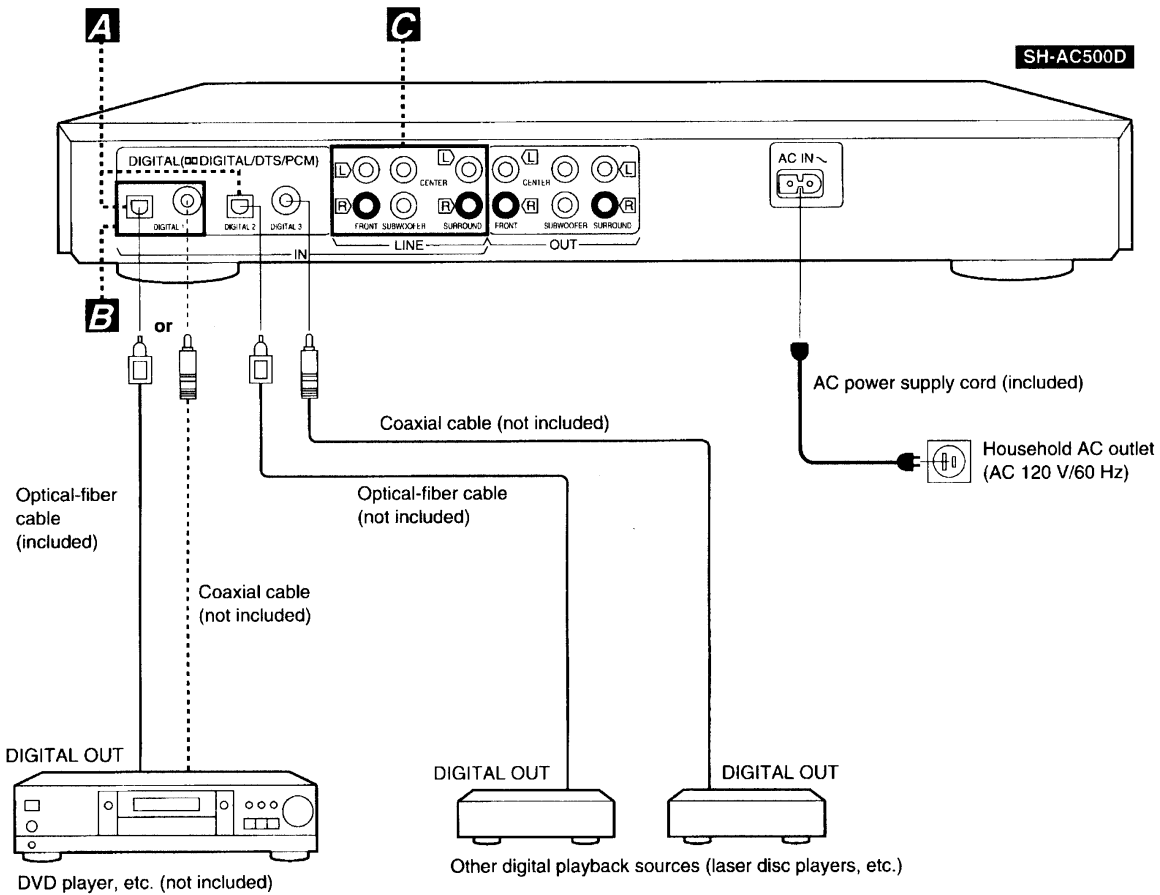

Connection for optical-fiber cable

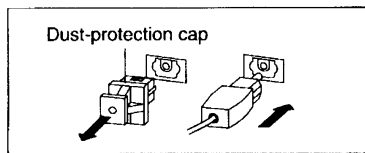

Note

- Do not bend the optical-fiber cable at a sharp angle.
- If the digital optical connector is not going to be used, be sure to attach the dust-protection cap to prevent exposure to dust.

“DIGITAL 1” terminals

Disconnect the coaxial cable from the DIGITAL 1 terminal when using an optical fiber cable. Only the coaxial cable is recognized if both types are connected.

“LINE IN” terminals

(Only if a control amplifier has not been connected.)

You can connect a set-top box tuner for digital television or similar decoder.

If “LINE” is selected with the input selector on this unit, the signals received through these terminals are output as they are without passing through any sound control circuits (i.e. no volume or other sound adjustments can be made with this unit.)

Note

- Dolby Digital RF (radio frequency) signals cannot be decoded with this unit even if a unit that has Dolby Digital RF output terminals is connected to this unit.
- Turn off the power to this unit if unusual hissing or beat sounds are heard while listening to FM, AM, or television broadcasts.

Speaker setting

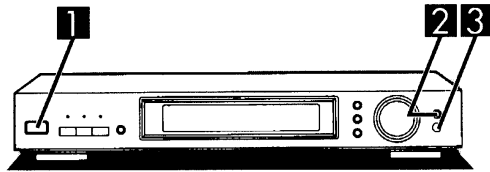

Set the types and presence of the speakers before enjoying the sound by reproducing the input source.

Before proceeding:

Check the frequency range of each speaker to be used. Consider speakers capable of playing back low frequency sounds (below around 100 Hz) as **LARGE**. Consider speakers not capable of playing back low frequency sounds as **SMALL**.

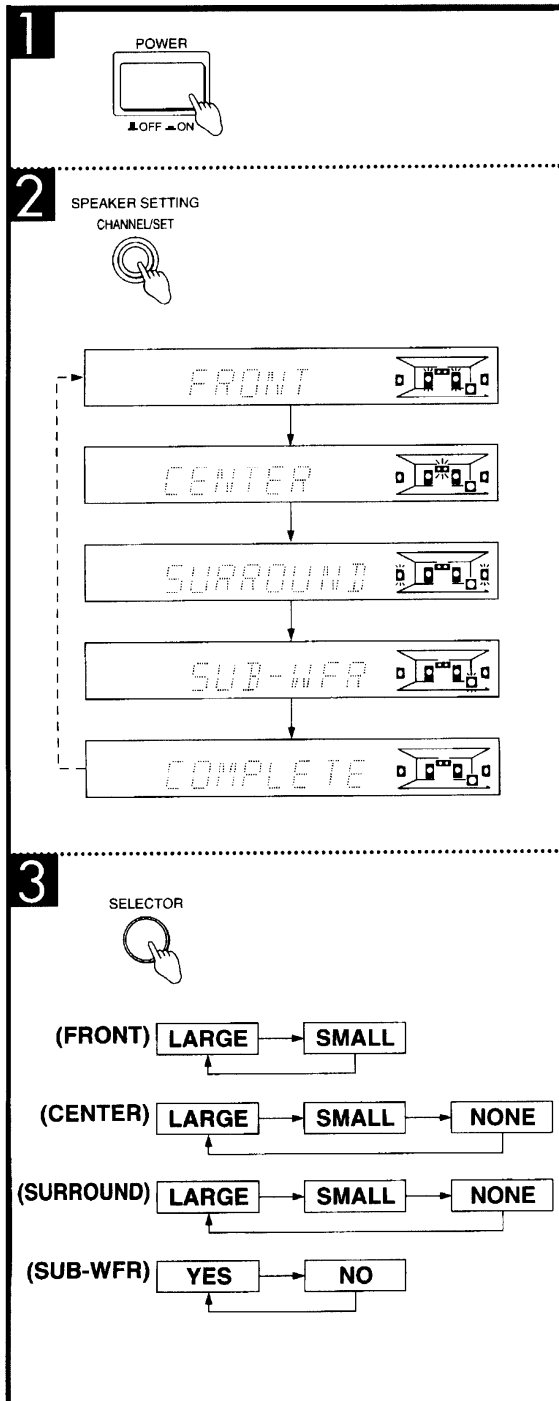

1 Press POWER.

2 Press CHANNEL/SET, and select the channel for which the speaker is to be set.

Each time the button is pressed, the channel display is switched in the listed order.

FRONT: Front speakers **CENTER:** Center speaker

SURROUND: Surround speaker **SUB-WFR:** Subwoofer

COMPLETE: Select this when you have completed the settings.

The selected channel is shown on the display for approx. 2 seconds. The current setting for that channel is then shown as a flashing display. The indicator corresponding to the selected speaker also continues to flash.

3 Press SELECTOR, and set the type (**LARGE**, **SMALL**) and presence (**YES**, **NO** or **NONE**) of the speaker.

Each time the button is pressed, the display is switched in the listed order.

LARGE: select if the speaker can produce low frequency sounds,

SMALL: select if the speaker cannot produce low frequency sounds,

NONE: select if you are not using a center speaker or surround speakers,

YES: select if you are using a subwoofer,

NO: select if you are not using a subwoofer.

The sound for speaker channels that are set to "NONE" or "NO" are output from the front speakers. DTS format software, however, depends upon all channels being operable, and so the sound for speakers not connected is not heard at all, no matter what settings are made.

4 Repeat steps 2 and 3 to complete the settings for all the channels.

5 Press CHANNEL/SET to select "COMPLETE".

The settings are now entered into the unit's memory. The display goes out after about 2 seconds and the previous display reappears.

The speaker indicators light up unless "NONE" or "NO" has been selected for the corresponding channel.

Note

If no buttons are pressed for approx. 10 seconds during the setting process, all previous settings are canceled, the setting mode is released, and the original display is restored. Begin the setting process again if this occurs.

For your reference:

The setting remains as it is until changed by the above procedure, even after the power has been turned off.

Speaker output adjustments

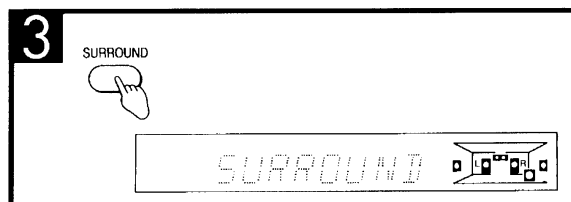
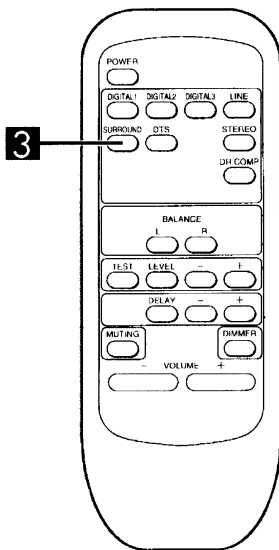
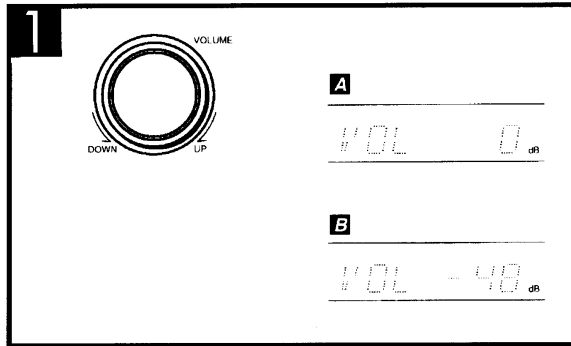
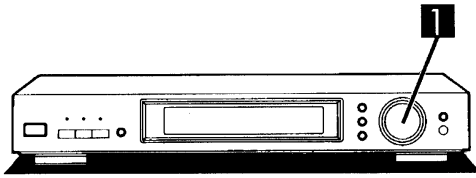

Set the initial output level first, then proceed to adjust the output level for each speaker channel.

Setting the initial volume level

When this unit is connected to a receiver (or amplifier) that has 6 channel discrete input terminals:

- 1** Set the volume level to 0 dB using this unit's **VOLUME** control. **A**
- 2** Set the volume control of the receiver (or amplifier) to the position normally used for enjoying the source.

If the test signal, described below in "Speaker output adjustment", is too soft, adjust the volume on the receiver (or amplifier).

Note

If the input level to the receiver (or amplifier) is too loud, lower the volume level using this unit's **VOLUME** control.

When this unit is connected to three standard stereo amplifiers:

- 1** Set the volume level to around **-48 dB** using this unit's **VOLUME** control. **B**

(If this unit is connected to three integrated amplifiers:)

- 2** Set the volume control of the integrated amplifiers to the position normally used for enjoying the source.

If the test signal, described below in "Speaker output adjustment", is too soft or too loud, adjust the volume on this unit.

Adjust the output level of each speaker **Remote control only**

Use the test signal to adjust the output level of the center speaker, surround speakers and subwoofer.

Note

If the output from the front speakers is unbalanced, make balance adjustments on the receiver or amplifier before continuing with the following. (Refer to the instruction manual of the component.)

If the receiver or amplifier cannot be used to make balance adjustments, they can be made on this unit.

- 3** Press **SURROUND** to select the surround mode.

"SURROUND" appears on the display.

(Continued on next page)

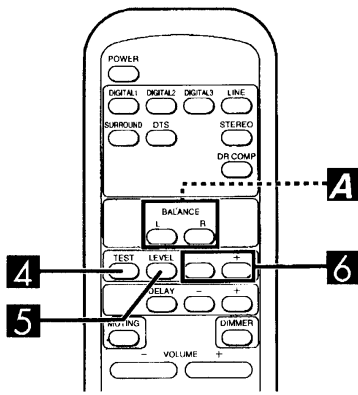

4 Press TEST to output the test signal.

“TEST” appears on the display, and the speaker indicator corresponding to the speaker whose outputting sound flashes.

The test signal is automatically output from each speaker for 2 seconds in the following sequence:

L → C → R → RS → LS → SW

- L: Front speaker (left)
- C: Center speaker
- R: Front speaker (right)
- RS: Surround speaker (right)
- LS: Surround speaker (left)
- SW: Subwoofer

(Speakers for which NONE or NO has been set are skipped.)

Note

If the left and right front speaker balance is poor, do not proceed with the next step until balance has been improved with the procedure described below (A).

5 Press LEVEL to select the speaker channel to adjust.

The output level appears on the display, and the speaker indicator for the selected speaker flashes.

Each time the button is subsequently pressed, the speaker whose level is to be set is selected in the listed sequence. (Speakers for which NONE or NO has been set are skipped.)

6 Press LEVEL [-] or [+] to adjust the output level.

Channels C, RS, LS, and SW can be adjusted between -12 dB and +12 dB. Set them so that the output from each channel appears to be the same as that from the front speakers.

7 Repeat steps 5 and 6 to adjust the output of each channel to approximately the same apparent level.

To stop the test signal

Press TEST.

Using this unit to adjust the balance of the left and right front speakers A

Make the adjustments while listening to the test signal put out in step 4 above.

Press BALANCE [L] or [R] on the remote control to adjust the level balance.

The left/right balance appears on the display.

Each time the button is subsequently pressed, the output level of the front speaker opposite to the button pressed is decreased. (i.e. when the L button is pressed, the output level of the R speaker is decreased.)

The original display is restored if a button isn't pressed for 4 or more seconds.

Note

The balance of the surround speakers cannot be adjusted using the BALANCE buttons.

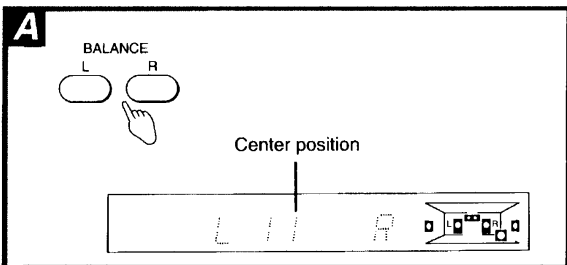
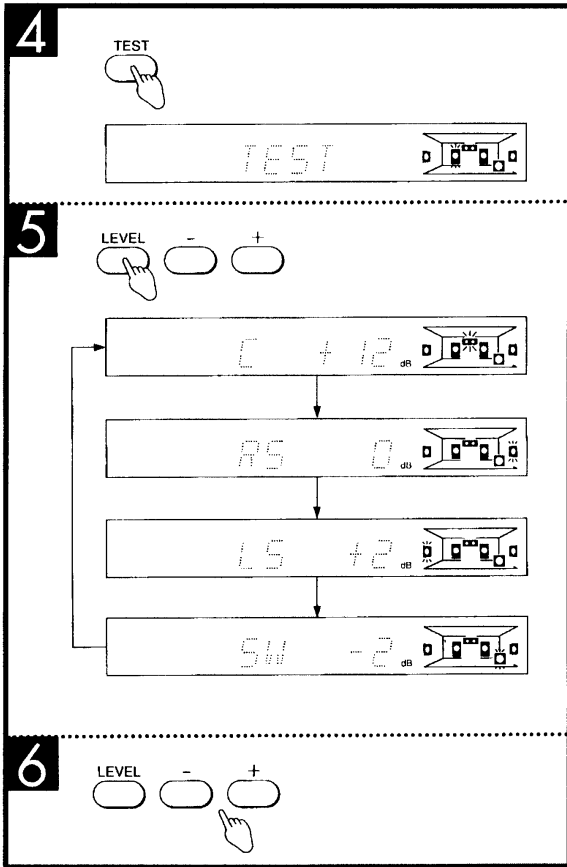

Delay time adjustments

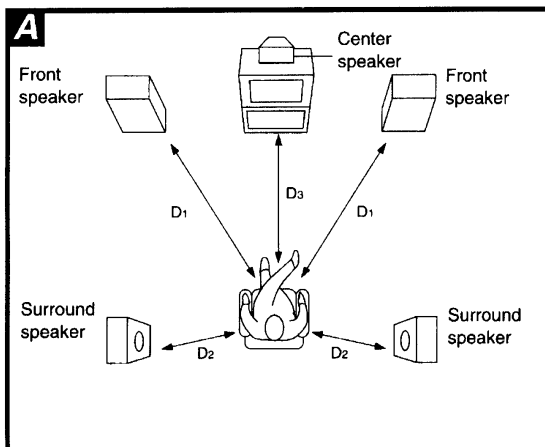
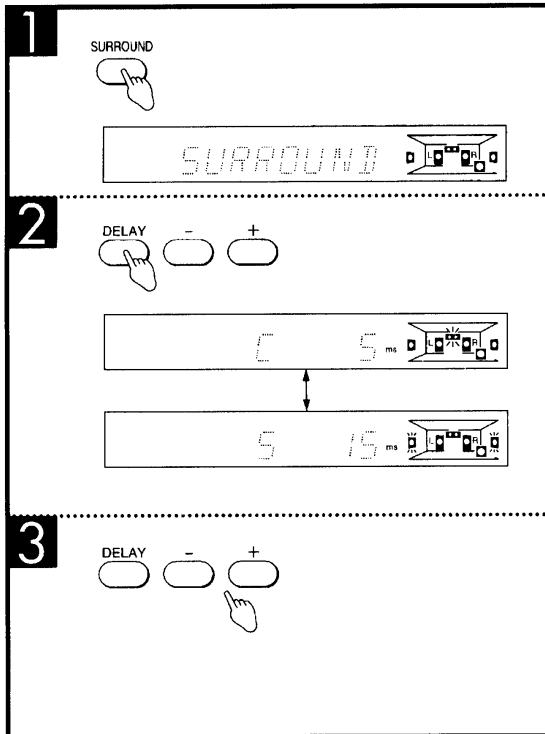
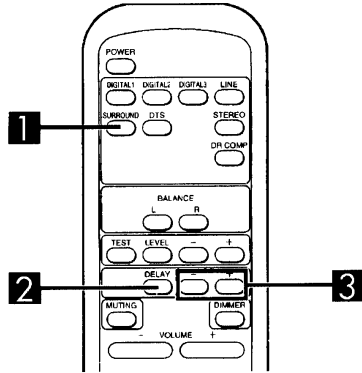

By adjusting the delay time, the difference in the distance from the viewing and listening position to the front speakers and the distance to the center speaker and surround speakers can be offset and made equal. This achieves better sound localization and makes a more life-like reproduction of the sound field possible.

Remote control only

- 1 Press SURROUND to select the surround mode.**

"SURROUND" appears on the display.

- 2 Press DELAY to select the channel to be adjusted.**

Each time the button is subsequently pressed, the channel whose delay time is to be set is selected alternately:

C (Center speaker) ↔ S (Surround speakers)

For each channel, the delay time is displayed, and the speaker indicator for the corresponding speaker flashes.

The display is restored if a button isn't pressed for 4 or more seconds.

Note

Speakers for which NONE has been set are skipped.

- 3 Press [-] or [+] to set the delay time.**

When the button is pressed, the current delay time is displayed. Each time the button is pressed, the delay time will change. The delay time increments are different depending on the speaker as follows.

Speaker	Available delay time setting (ms)
Center	0, 1, 2, 3, 4, 5
Surround	0, 5, 10, 15

Note

Please note the following if delay time is adjusted while playing back a source:

Adjustment is not possible if the source is DTS format.

While the PRO LOGIC indicator is a light, the center channel cannot be adjusted and 15 ms are added to the delay times listed for the surround channel when displayed.

To calculate the delay time **A**

D_1 : Distance from front speaker

D_2 : Distance from surround speaker

D_3 : Distance from center speaker

Setting the center channel delay time:

If D_1 is equal to or less than D_3	Set to 0 ms
If D_3 less than D_1	Increase 1 ms for every 30 cm (1 foot) of difference between D_1 and D_3

Setting the surround channel delay time:

If D_1 is equal to or less than D_2	Set to 0 ms
If D_2 is less than D_1	Start at 0 ms and increase by 5 ms for every 1.5 m (5 feet) of difference between D_1 and D_2

■ Enjoying sound in a variety of reproduction modes

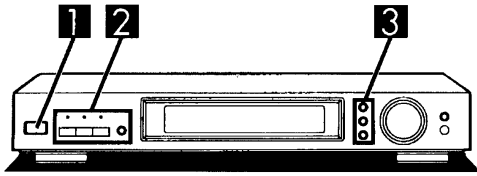

This unit enables sound to be enjoyed in three reproduction modes – SURROUND, DTS and STEREO.

1 Press POWER.

Turn on the power to the other AV components as well.

2 Press one of the input select buttons to select the input source.

The indicator above the pressed button now lights.

DIGITAL 1: Selects the source connected to the DIGITAL 1 terminal. The unit automatically recognizes whether the source is connected through the optical fiber cable or the coaxial cable.

Note

If both types are connected at the same time, only the coaxial cable is recognized. Disconnect the coaxial cable if the external unit is connected with the optical fiber cable.

DIGITAL 2: Selects the source connected to this terminal.

DIGITAL 3: Selects the source connected to this terminal.

LINE: Selects the source connected to the LINE terminal. If a control amp has been connected to the LINE terminal, select the input source on it as well.

When DIGITAL 1, 2 or 3 has been selected:

The reproduction modes in step 3 can be selected.

When LINE has been selected:

The analog sound signals input through LINE IN terminals are directly output to the left and right front speakers via the connected component. "THROUGH" appears on the display.

Note

Only the POWER button and select buttons function when LINE has been selected.

3 Press SURROUND, DTS or STEREO to select the reproduction mode.

The selected reproduction mode appears on the display (➔ see the previous page for descriptions of the modes.)

4 (When this unit is connected to a receiver (or amplifier) that 6 channel discrete input terminals:)

Set the receiver (or amplifier) to the 6 channel discrete input mode.

Note

If this unit is connected to three integrated amplifiers, set the input selector on the amplifiers to the connected input terminal such as the "AUX" terminals.

(Refer to the instruction manuals of the components.)

(Continued on next page)

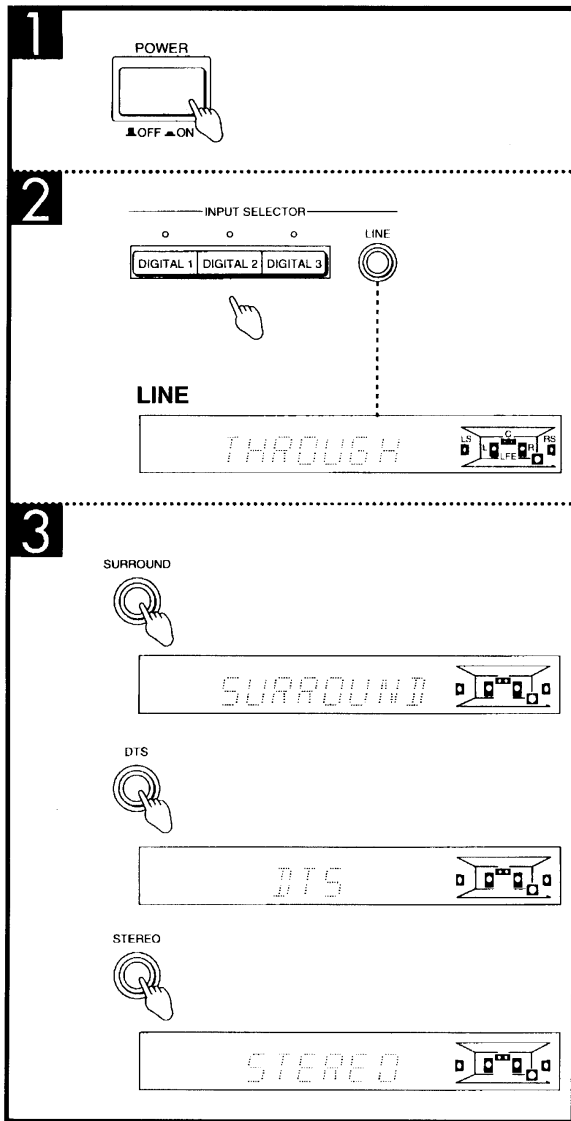

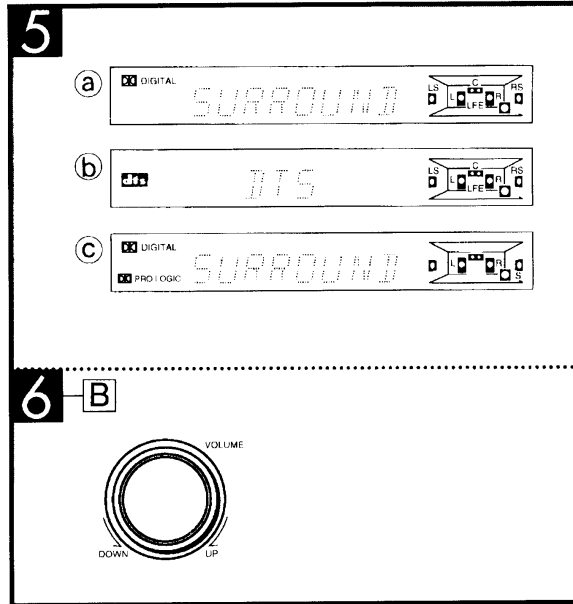
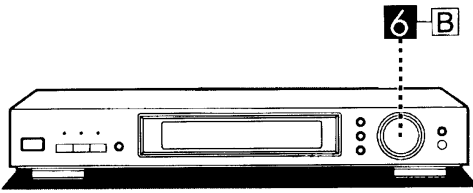

5 Start playing the sound source.

The surround indicators

- Ⓐ DIGITAL: Lights if the source is Dolby Digital Format.
- Ⓑ DTS: Lights if the source is DTS format.
- Ⓒ PRO LOGIC: Lights when Dolby Surround parts of Dolby Digital format software are played back, or when playing audio CDs in the SURROUND mode.

Note

- Only Dolby Digital, DTS or PCM signals ※ can be reproduced.
The digital input signal of sampling frequencies 96 kHz and other signal formats such as MPEG cannot be reproduced on this unit.
- When playback is started, the sound may be cut or interrupted before the input source is confirmed as Dolby Digital or DTS.

※ **PCM signal:** This refers to the recording format of signals (44.1 kHz, linear 16 bits) used for audio CDs

6 Adjust the volume.

Set the volume on the receiver (or amplifier) and this unit to the initial level. Any subsequent volume adjustments should be done as follows.

Ⓐ (When this unit is connected to a receiver (or amplifier) that has 6 channel discrete input terminals:)

Adjust the volume using the volume control on the receiver (or amplifier).

If input to the receiver (or amplifier) is excessive, reduce the volume on this unit slightly.

Ⓑ (When this unit is connected to three standard stereo amplifiers or three integrated amplifiers:)

Adjust the volume using this unit's VOLUME control.

To adjust the volume of the components connected to the stereo control amplifier, use the volume control on the stereo control amplifier.

After use

Reduce the volume on the component you are using to control the volume (the receiver, amplifier or this unit) to the minimum level, then turn off the power to this unit and the other components.

Other functions

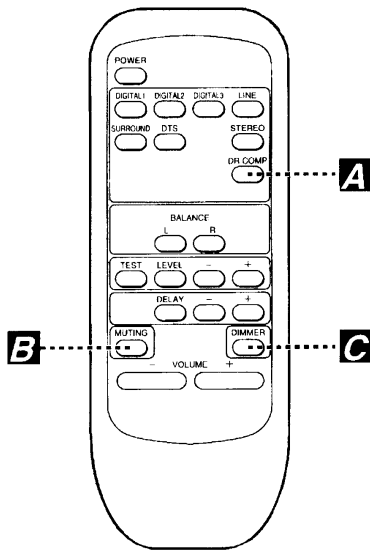

Setting the midnight mode (dynamic range compression)

"Dynamic range compression" (DR COMP) is a function for compressing the dynamic range (reproduction level range) of audio signals. It is used for viewing movie software late at night or at other times when high volume levels are not desirable.

This function only works with DR COMP compatible Dolby Digital format software.

Remote control only

Press DR COMP. **A**

The "DR COMP" indicator lights.

When the button is pressed again, the function is released, and the indicator goes off.

For your reference:

When DR COMP is on, scenes that already have a low sound level will be heard as they are. When scenes that are loud occur, the function acts to reduce the peak level.

The sound field will remain intact even if DR COMP is functioning.

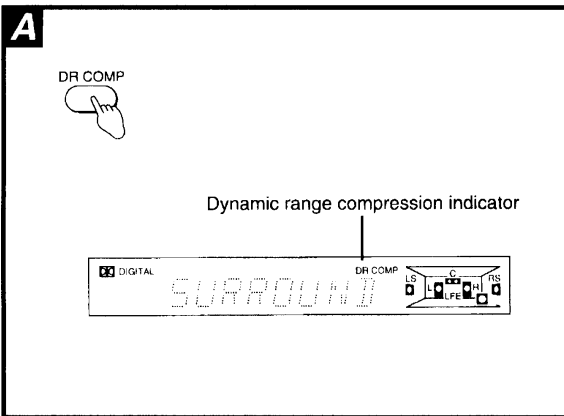

Muting the sound temporarily

Remote control only

Press MUTING. **B**

During muting, the message "MUTING ON NOW" scrolls across the display.

When the button is pressed again, the original volume level is restored. When the unit's power is switched off, muting is canceled.

Selecting the display panel brightness

Remote control only







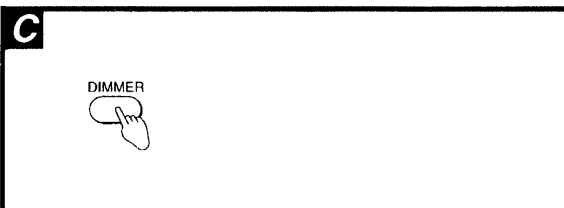
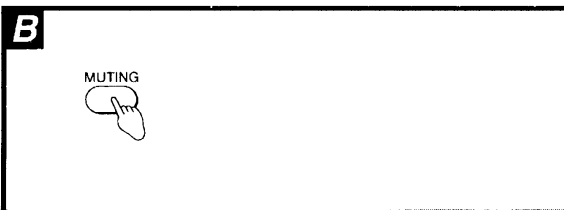

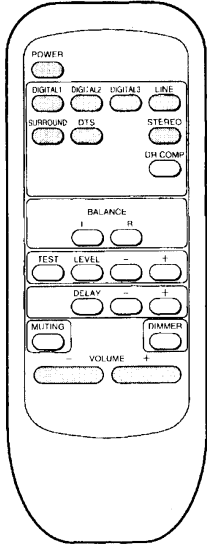

Press DIMMER. **C**









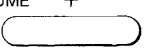

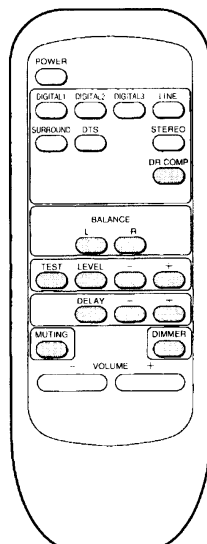

The display panel is dimmed.

When the button is pressed again, or when the unit's power is switched off, the original brightness is restored.



■ Remote control quick reference

	Functions which are also available from the main unit	
	To turn the unit ON/OFF	POWER 
	Selecting the input source	DIGITAL 1 DIGITAL 2 DIGITAL 3 LINE    
	Selecting the SURROUND reproduction mode	SURROUND 
	Selecting the DTS reproduction mode	DTS 
	Selecting the STEREO reproduction mode	STEREO 
Adjusting the volume	- VOLUME +  	

	Functions which are only available from the remote control	
	To turn on the midnight mode	DR COMP 
	Adjusting the volume balance between the left and right front speakers	BALANCE L R  
	Outputting the test signal to adjust the output level of each speaker	TEST 
	Selecting the speaker channel and adjusting its output level	LEVEL → - +   
	Selecting the speaker channel and adjusting its delay time	DELAY → - +   
	Muting the sound temporarily	MUTING 
Selecting the display panel brightness	DIMMER 	

■ Operation Checks

"ATTENTION SERVICER" Some chassis components may have sharp edges. Be careful when disassembling and servicing.

1. This section describes procedures for checking the operation of the major printed circuit boards and replacing the main components.
2. For reassembly after operation checks or replacement, reverse the respective procedures. Special reassembly procedures are described only when required.
3. Select items from the following index when checks or replacement are required.

• Contents

- Checking Procedure For Each Major P.C.B. page 16 ~ 17

■ Checking Procedure For Each Major P.C.B.

1. Checking of the Control, Display, Volume and Power Switch P.C.B.

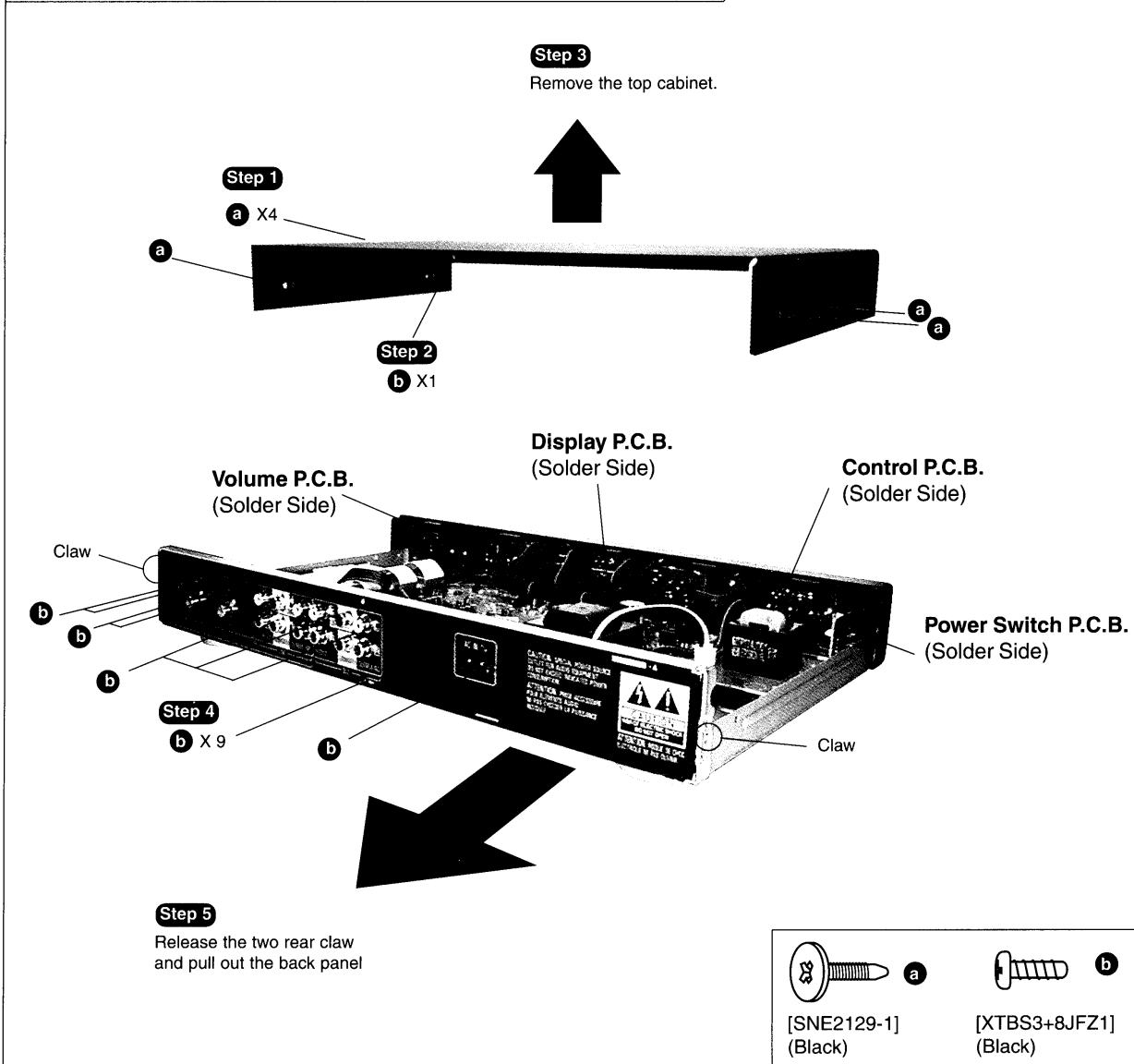

2. Checking of the AC-3 Module Unit, Display, Sub-Transformer, Digital Input and Main P.C.B.

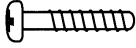
- | | | |
|---|----------|--------------------------|
|  | b | [XTBS3+8JFZ1]
(Black) |
|  | c | [XTB3+20JFZ]
(Black) |

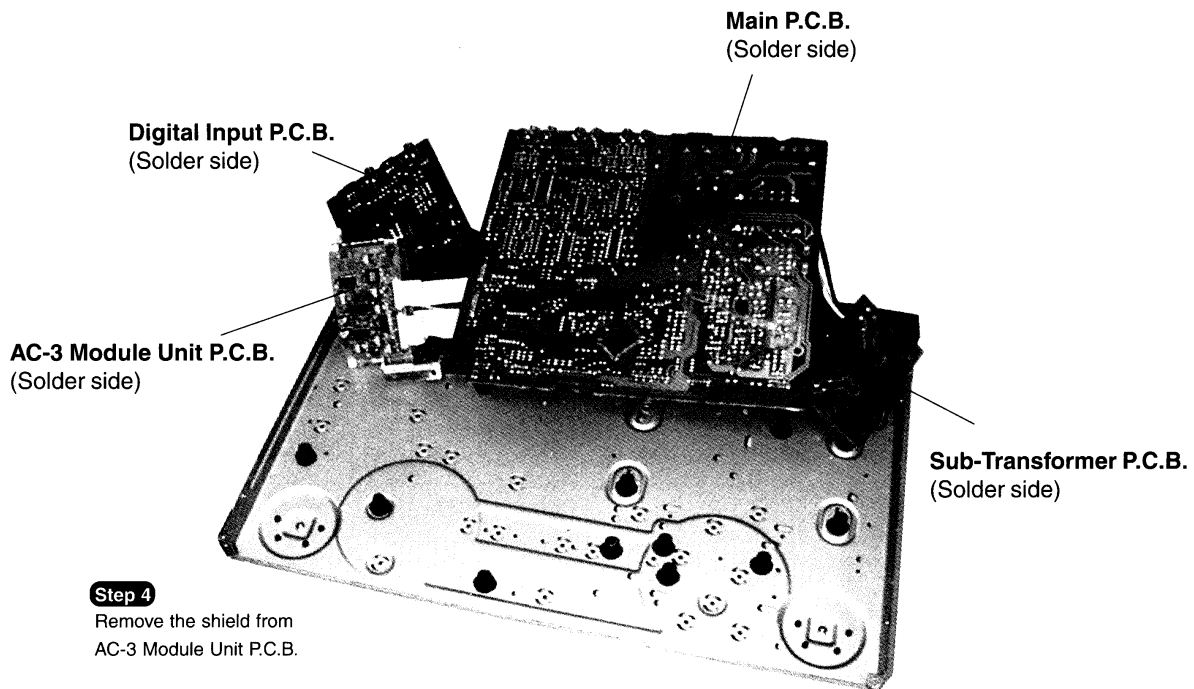
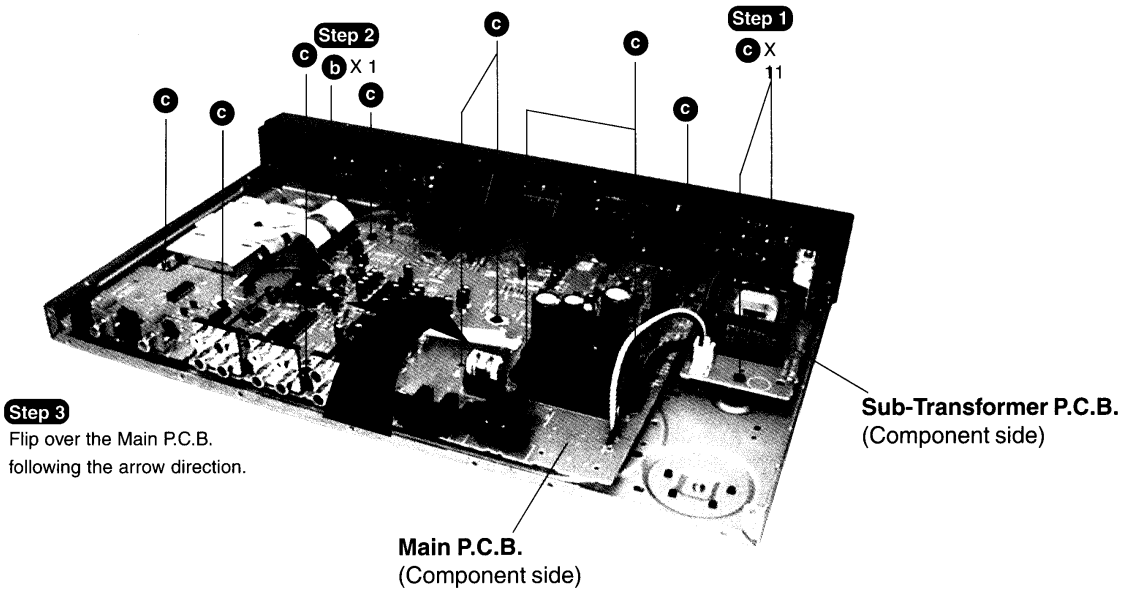

■ Terminal Functions Of ICs

• IC901 (M38B53M4057F) System Microprocessor

Pin No.	Mark	I/O	Function	Pin No.	Mark	I/O	Function
1	XCS	O	Key Input 1 ~ 2	41~56	SEG1~SEG16	O	FL digit signal output
2	SK	O	Thermal/Over load input 1	57	INIT	I	Diode input initial settings
3	DI	O	Key Input 4	58	-	I	Volume control output (Down)
4	DO	I	Thermal/Over load input 2	59	PDN	O	Volume control output (Up)
5~6	STB1~STB2	O	Stereo signal detect terminal	60	OVLERR	I	REC Mute control
7~8	RA~RB	I	Wake up timer LED	61	FRQ0	I	Serial data signal
9	--	I	Control of RDS IC (ST) stereo signal	62	FRQ1	I	Power limiter control output
10	RESET	I	Remote control terminal	63	AC3	I	Tuner control (CE) chip enable signal
11	CK	O	Reset detect terminal	64	AUDIO	I	Selector/Tuner (CK) clock signal
12	DATA	O	Control of RDS IC (CK) clock signal	65	CCS	O	Selector/Tuner (DT) data signal
13	VSS	-	Control of RDS IC (DT) data signal	66	CCLK	O	Selector control terminal
14	XIN	--	GND terminal	67	CDIN	O	MMD control terminal
15	XOUT	--	Crystal oscillator terminal (4 MHz)	68	CDOUT	I	Surround control (CK) clock signal
16	VDD/VCC	--	Crystal oscillator terminal (4 MHz)	69	SS	O	Surround control (DT) data signal
17~18	DIGITAL1~2	O	LED driver IC (DT) data signal	70	SCK	O	Surround control (CE) chip enable signal
19	LINE	O	SFC mode encoder input 1	71	MOSI	O	GND for A-D converter
20	STANDBY	O	SFC mode encoder input 2	72	MISO	O	Reference voltage for A-D converter
21	POWERSW	I	Selector encoder for input 1	73	AVSS	-	SD signal detect input
22	REMOTE	I	Blackout detection terminal	74	VREF	-	Encoder of surround mode selector input1
23	HOLD	I	Selector encoder for input 2	75	MRESET	O	Help LED control output
24	POWER	O	VCR2 control input	76	IFCD	I	Encoder of surround mode selector input2
25~27	A4053A~C	O	6 ch sw control output (ST)	77	TCS	O	Video selector control output A
28	VEE	--	Power supply for FL driver	78	TRST	O	Video selector control output B
29~30	MUTEA / S	O	Speaker B control output	79	KEY1	A/D	Key input 1
31~40	DIG10~DIG1	O	Muting control output	80	KEY2	A/D	Key input 2

■ Type Illustration of IC's, Transistors and Diodes

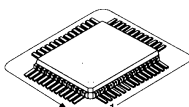
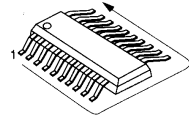
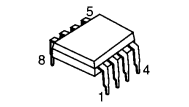
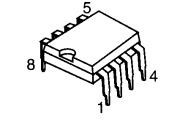
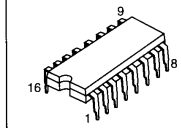
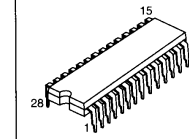
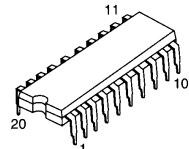
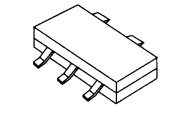
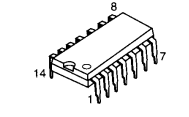
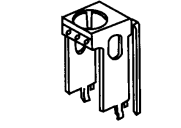
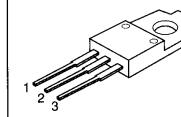
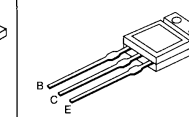
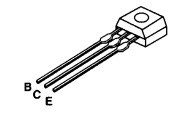
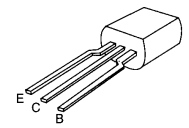
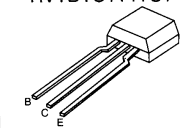
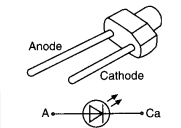
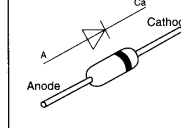
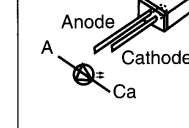
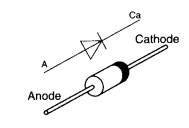
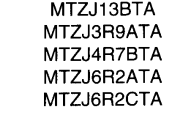
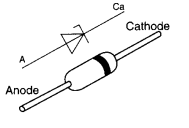
<p>M38B53M4057F CS4926-CL CS4226-KQ</p> 	<p>MX23C4000MC1</p> 	<p>NJM4580DD</p> 	<p>BR93LC46</p> 	<p>TC9212P TC4052BP</p> 	<p>TC9162AN</p> 
<p>TC74VHC574FL TC74VHC244FL</p> 	<p>TC7SHU04F85L</p> 	<p>NJM2060D</p> 	<p>RCD12042TE</p> 	<p>BA033T</p> 	<p>2SD2137PQTA</p> 
<p>2SD1915FTA 2SD1450RSTTA</p> 	<p>2SD592AQSTA 2SA992FEPTA 2SB621AQSTA</p> 	<p>2SA933SSTA 2SC1740SSTA RVTDTA114YST RVTDTTC114YST</p> 	<p>SLR325VCT31</p> 	<p>RVD1SS133TA</p> 	<p>LN846RPH</p> 
<p>RL1N4003N02</p> 	<p>MTZJ27DTA MTZJ13BTA MTZJ3R9ATA MTZJ4R7BTA MTZJ6R2ATA MTZJ6R2CTA</p> 				

Wiring Connection Diagram

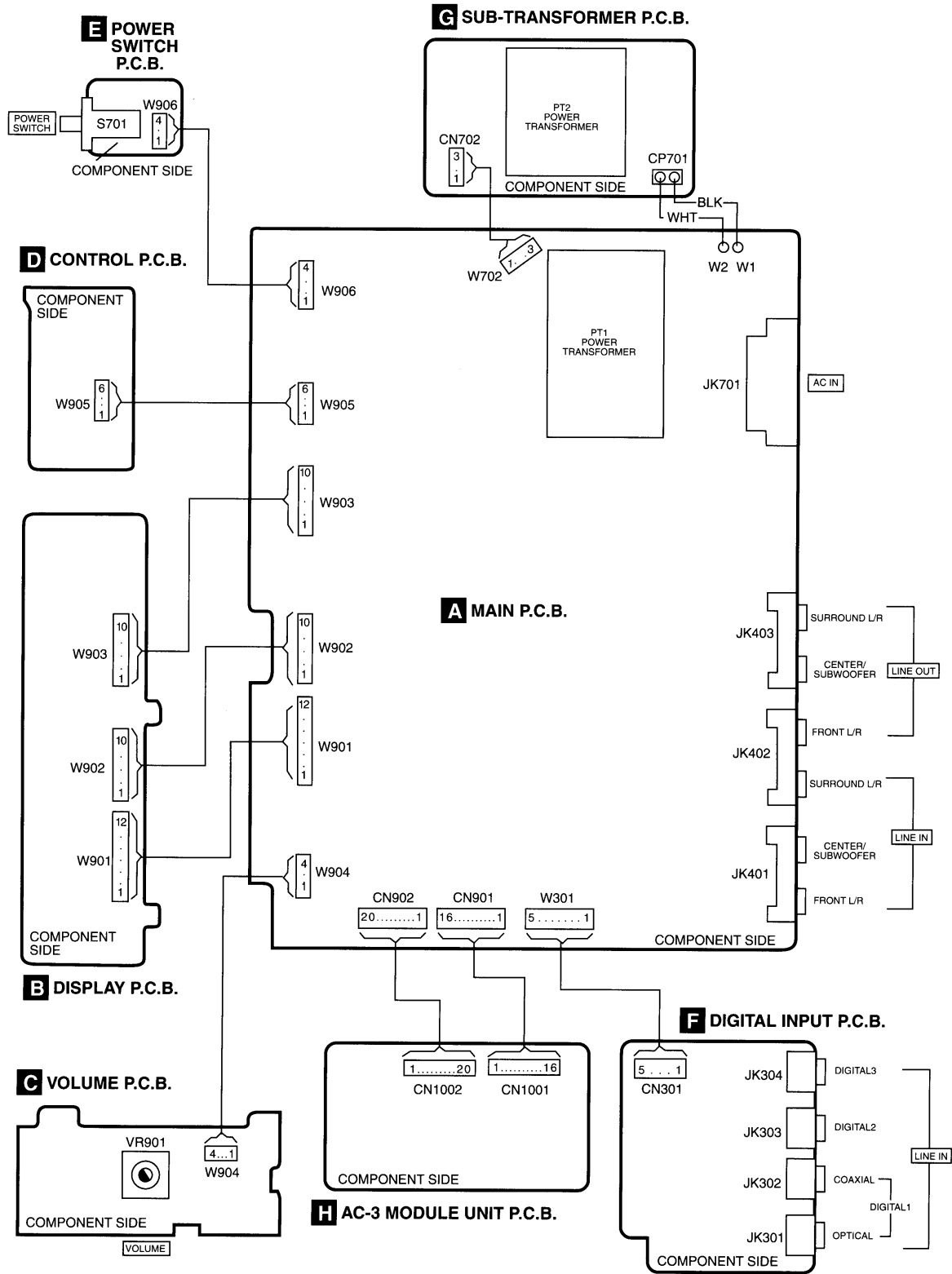

Block Diagram

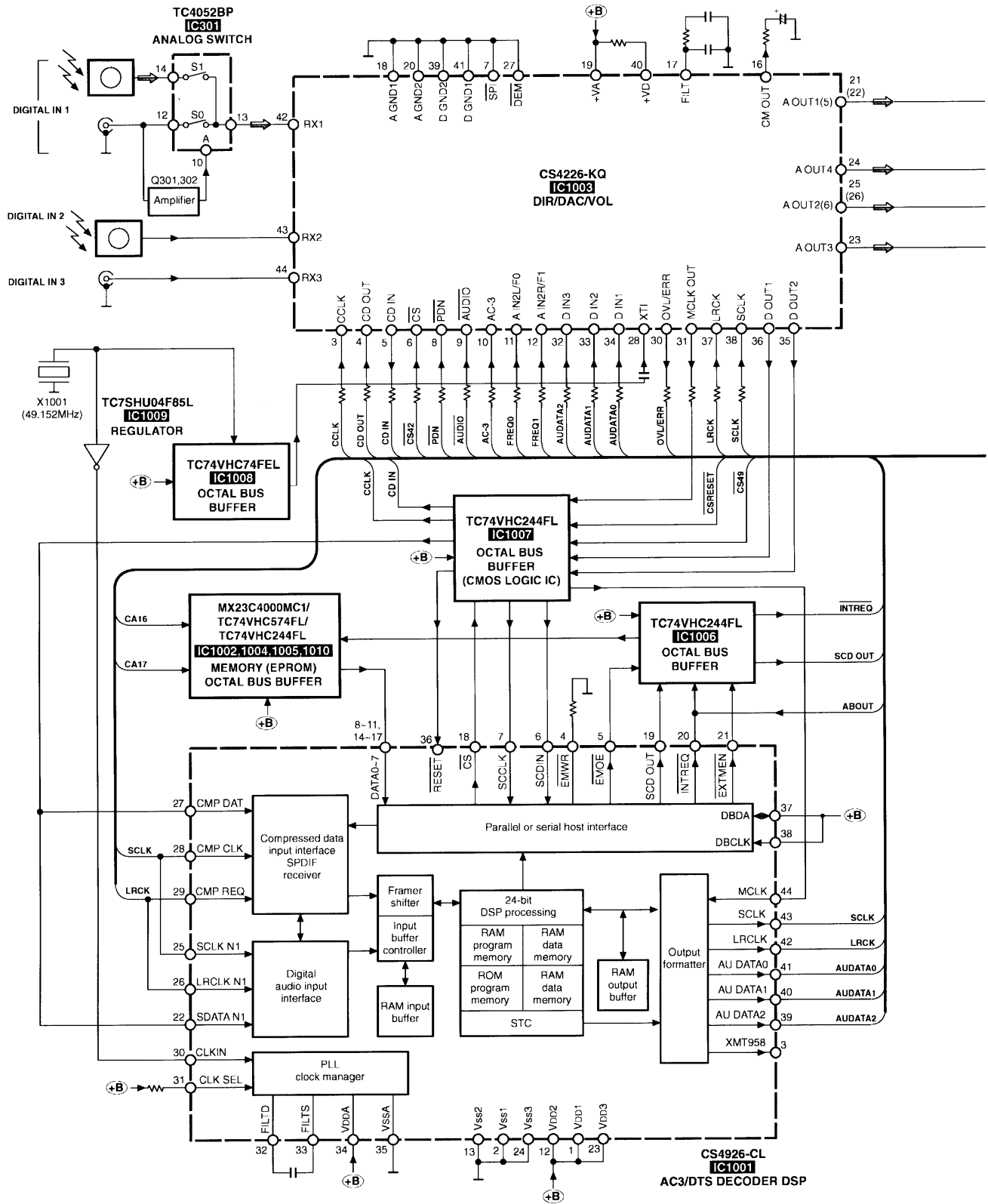

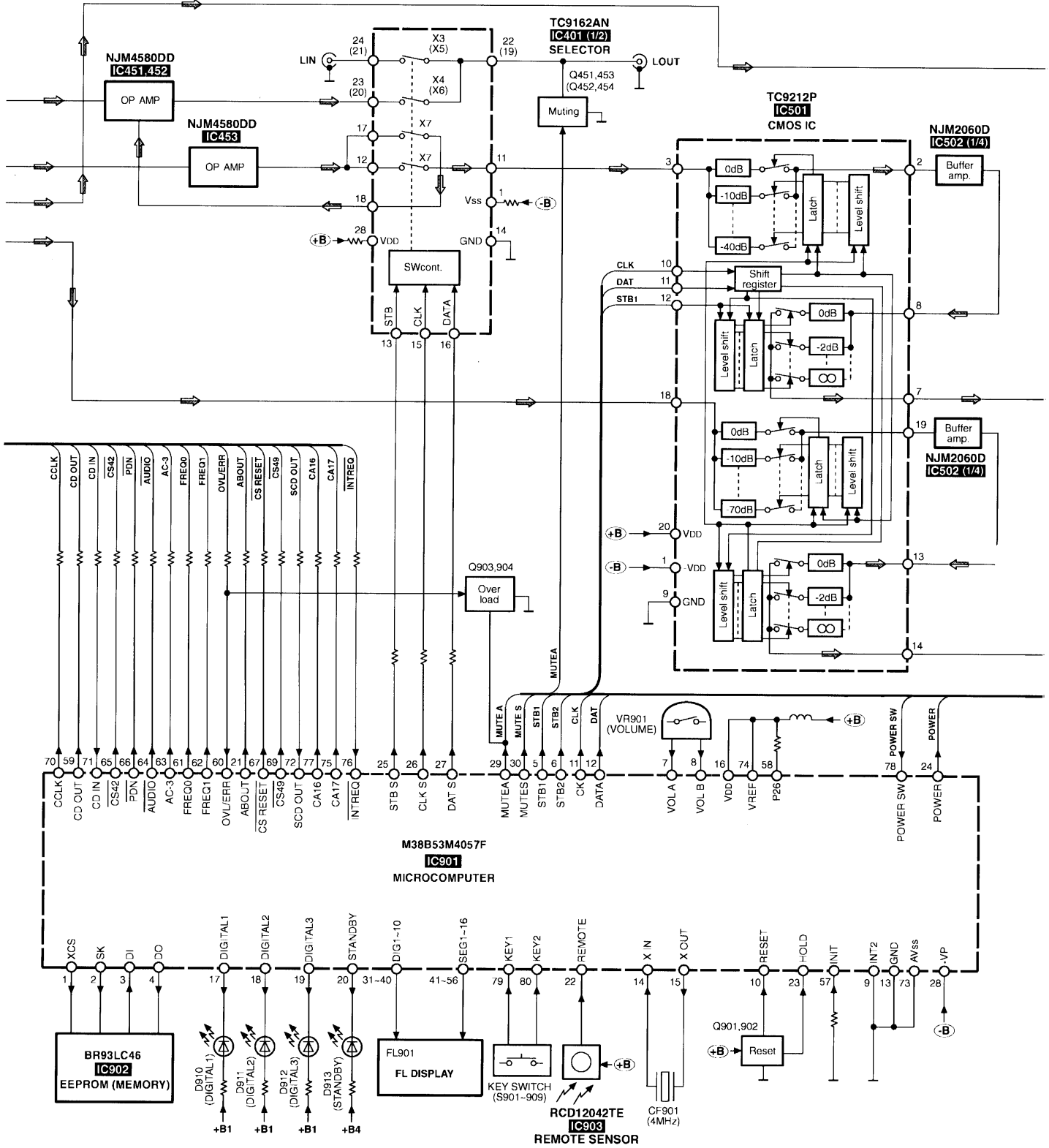

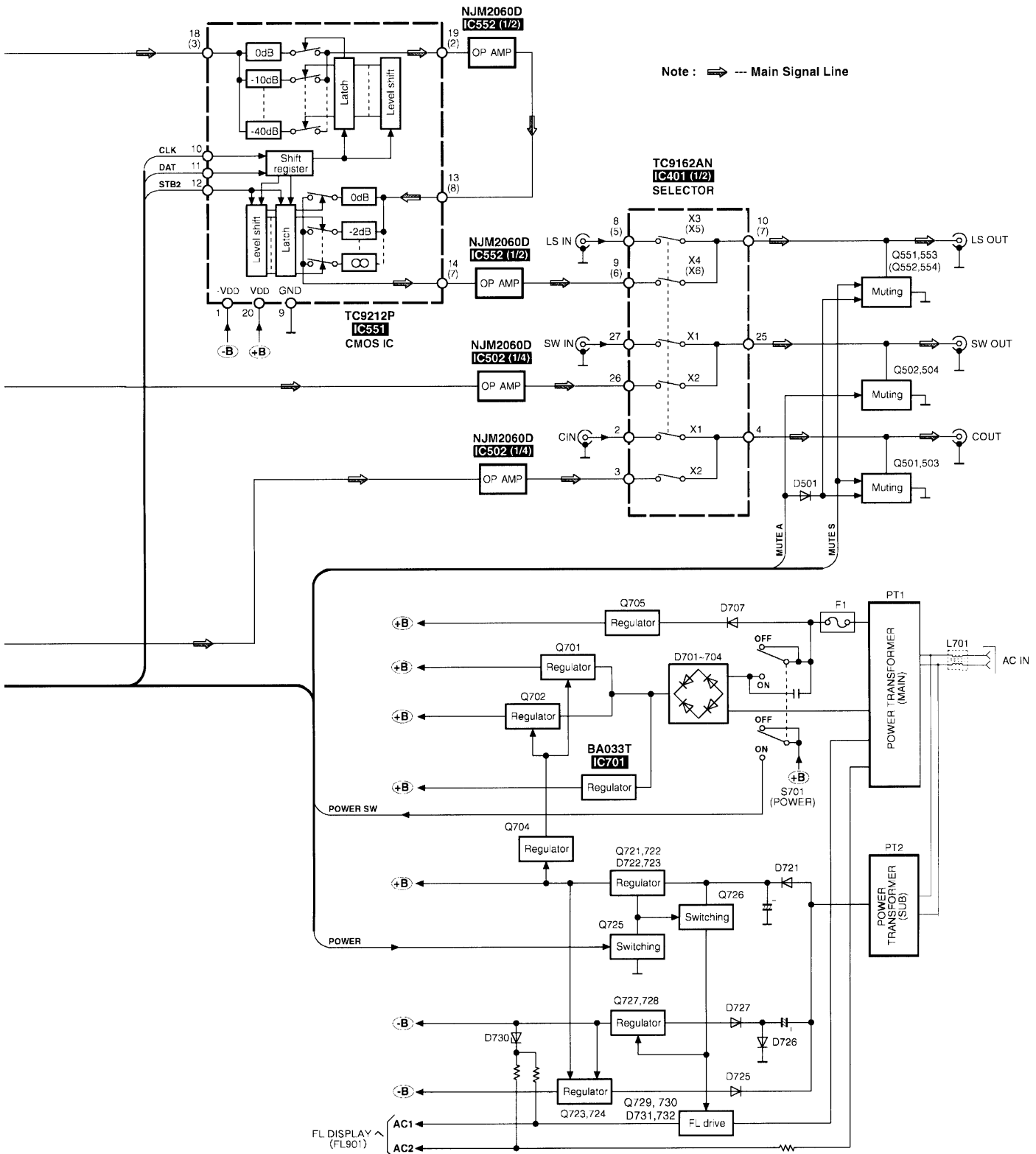

■ Schematic Diagram

	Page		Page
A MAIN CIRCUIT	26 ~ 27	E POWER SWITCH CIRCUIT	30
B DISPLAY CIRCUIT	25	F DIGITAL INPUT CIRCUIT	30
C VOLUME CIRCUIT	30	G SUB-TRANSFORMER CIRCUIT	27
D CONTROL CIRCUIT	30	H AC-3 MODULE UNIT CIRCUIT	28 ~ 29

(All schematic diagrams may be modified at any time with the development of new technology)

Note :

- | | | | | | |
|--------|---|-----------------|---------|---|-----------------------|
| • S701 | : | Power switch | • S906 | : | DTS switch |
| • S901 | : | Digital 1 | • S907 | : | Stereo switch |
| • S902 | : | Digital 2 | • S908 | : | Channel select switch |
| • S903 | : | Digital 3 | • S909 | : | Speaker select switch |
| • S904 | : | Line switch | • VR901 | : | Volume control |
| • S905 | : | Surround switch | | | |

• Signal line

 : +B line
  : - B line
  : Main signal line

- The voltage value and waveforms are the reference voltage of this unit measured by DC electronic voltmeter (high impedance) and oscilloscope on the basis of chassis. Accordingly, there may arise some error in voltage values and waveforms depending upon the internal impedance of the tester or the measuring unit.

• Importance safety notice:

Components identified by Δ mark have special characteristics important for safety. Furthermore, special parts which have purposes of fire-retardant (resistors), high-quality sound (capacitors), low-noise (resistors), etc. are used. When replacing any of components, be sure to use only manufacturer's specified parts shown in the parts list.

Caution !

IC, LSI and VLSI are sensitive to static electricity.

Secondary trouble can be prevented by taking care during repair.

- Cover the parts boxes made of plastics with aluminium foil.
- Ground the soldering iron.
- Do not touch the pins of IC, LSI or VLSI with fingers directly.
- Put a conductive mat on the work table.

SCHEMATIC DIAGRAM - 1

B DISPLAY CIRCUIT
(P.C.Board on page 35)

— : +B Line - - - : -B Line ⇨ : Main Signal Line

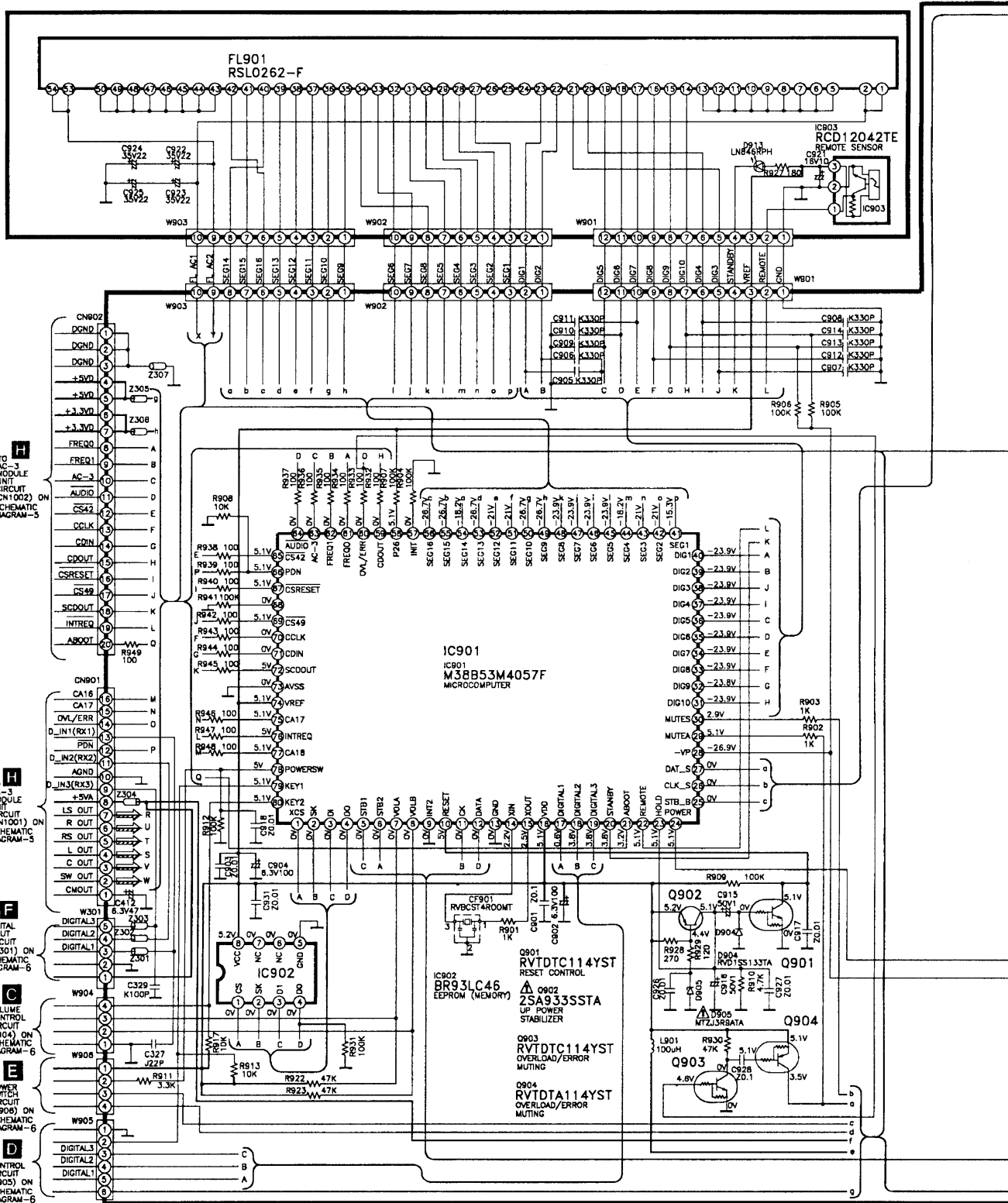

H TO AC-3 MODULE UNIT CIRCUIT (CN1002) ON SCHEMATIC DIAGRAM-5

H TO AC-3 MODULE UNIT CIRCUIT (CN1001) ON SCHEMATIC DIAGRAM-5

F TO DIGITAL INPUT CIRCUIT (CN301) ON SCHEMATIC DIAGRAM-6

C TO VOLUME CONTROL CIRCUIT (W904) ON SCHEMATIC DIAGRAM-6

E TO POWER SWITCH CIRCUIT (W906) ON SCHEMATIC DIAGRAM-6

D TO CONTROL CIRCUIT (W903) ON SCHEMATIC DIAGRAM-6

SCHEMATIC DIAGRAM - 2

A MAIN CIRCUIT
(P.C.Board on page 32)

— : +B Line - - - : -B Line ⇨ : Main Signal Line

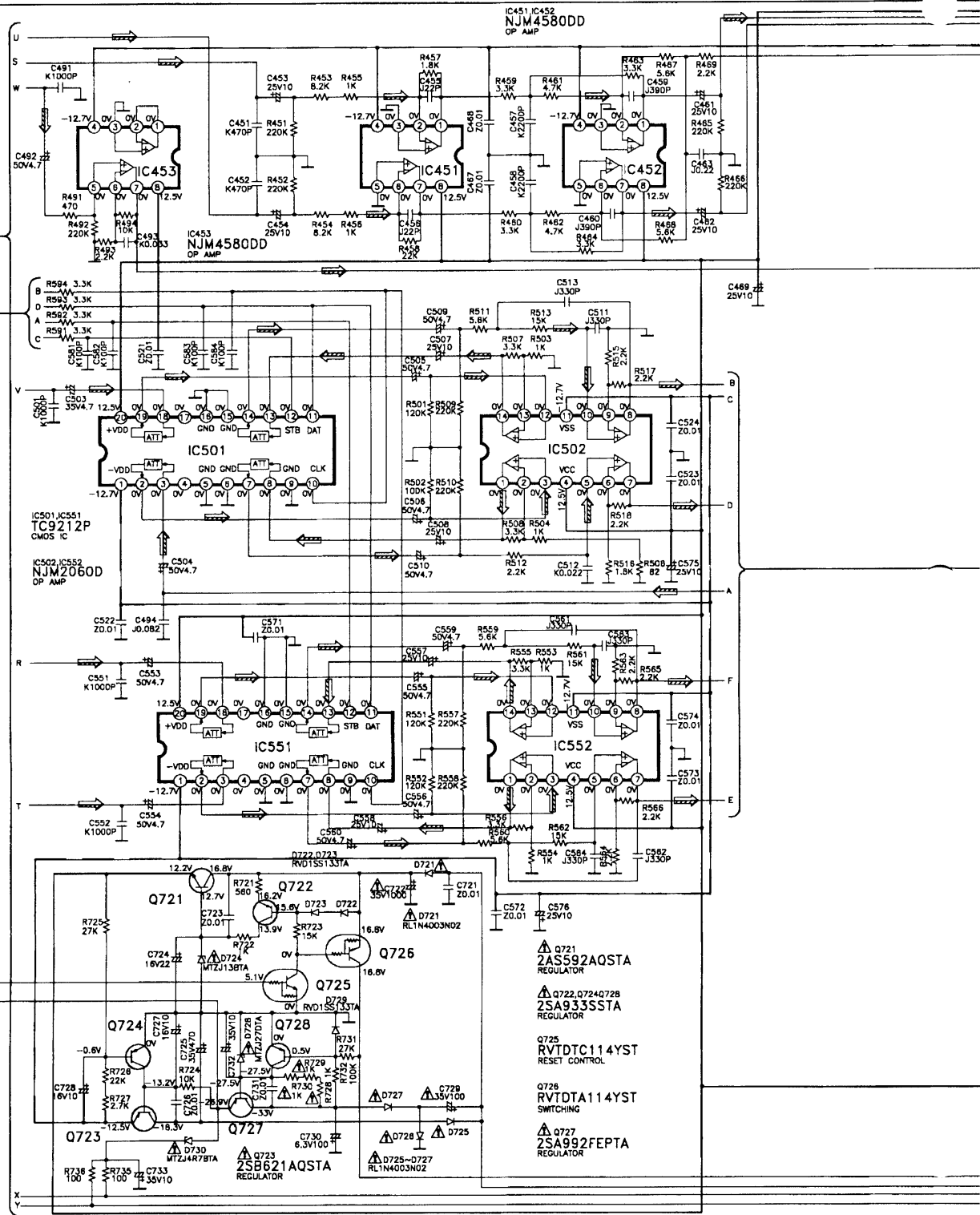

SCHEMATIC DIAGRAM - 3

— : +B Line - - - : -B Line ⇨ : Main Signal Line

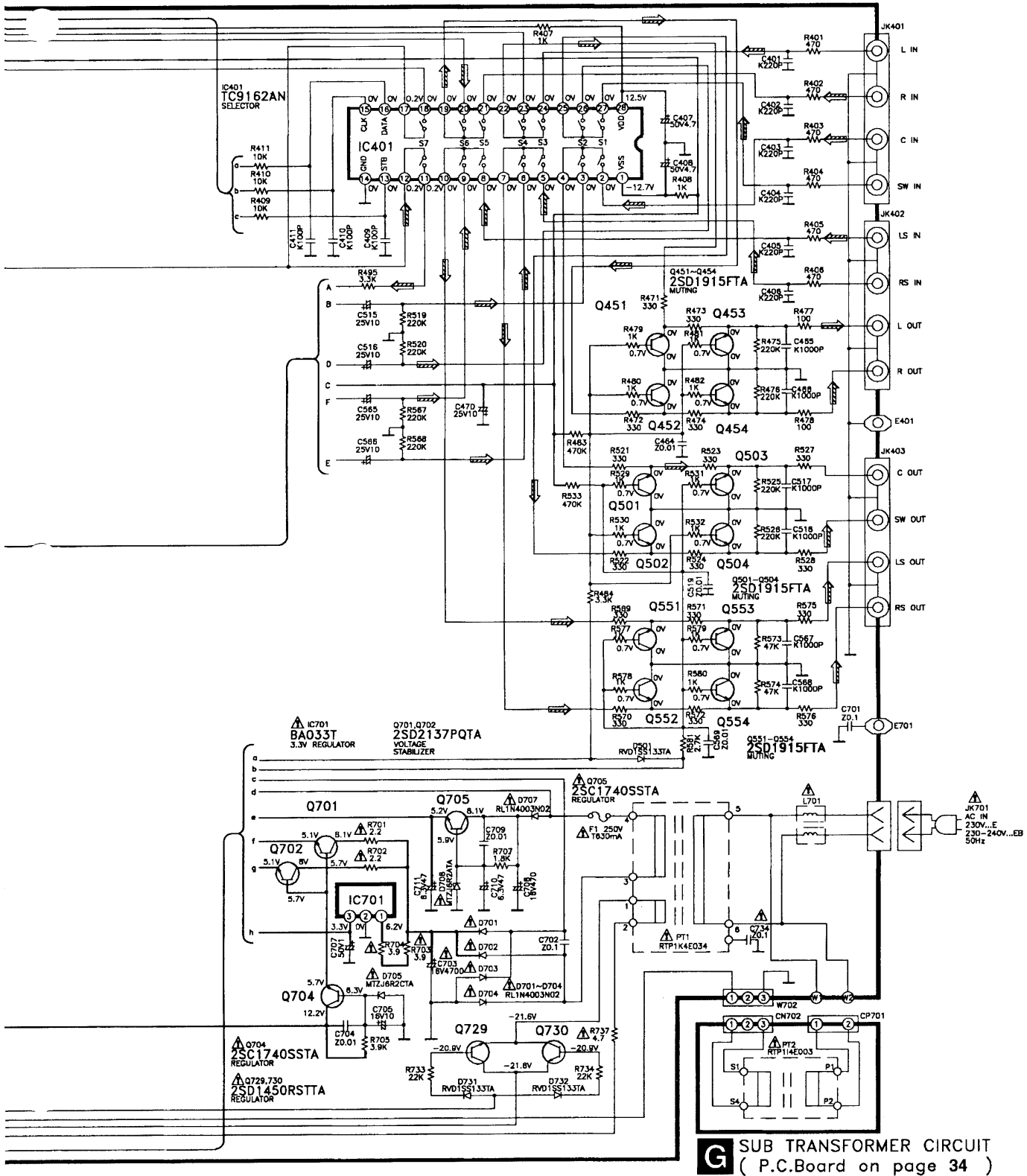

SCHEMATIC DIAGRAM - 4

H AC-3 MODULE UNIT CIRCUIT (P.C.Board on page 31)

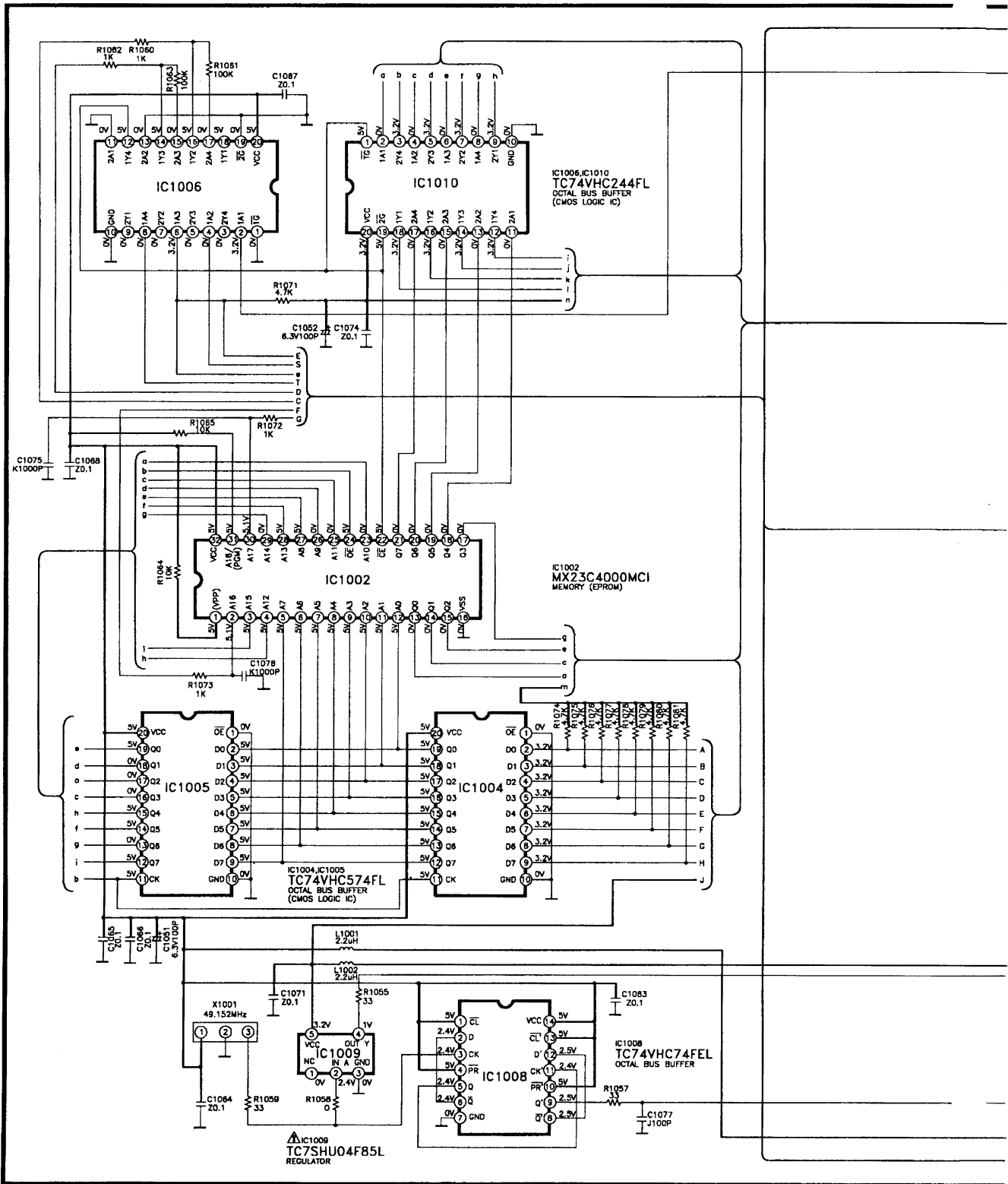

SCHEMATIC DIAGRAM - 5

— : +B Line ⇨ : Main Signal Line

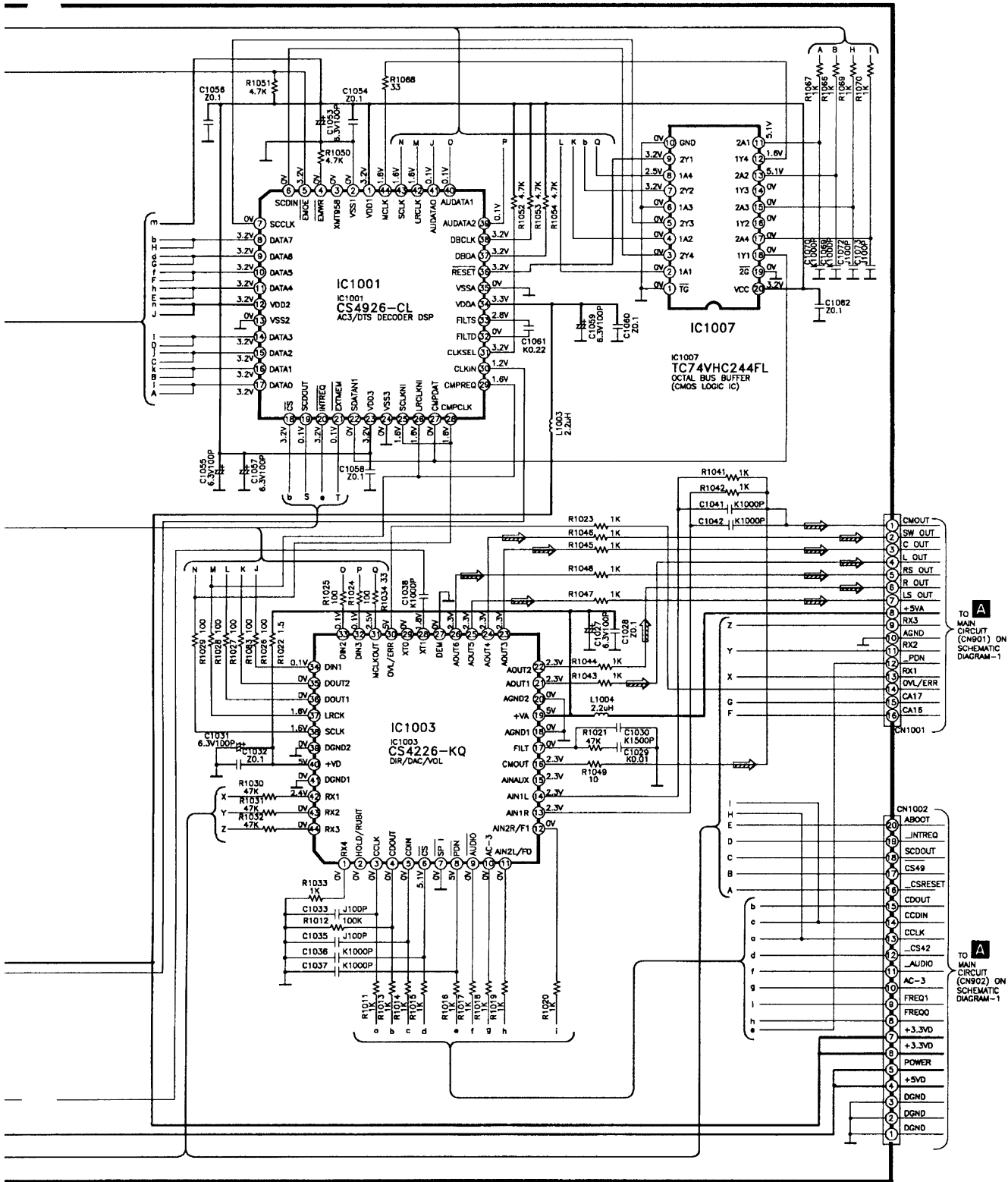

SCHEMATIC DIAGRAM - 6

F DIGITAL INPUT CIRCUIT
(P.C.Board on page 34)

—— : +B Line

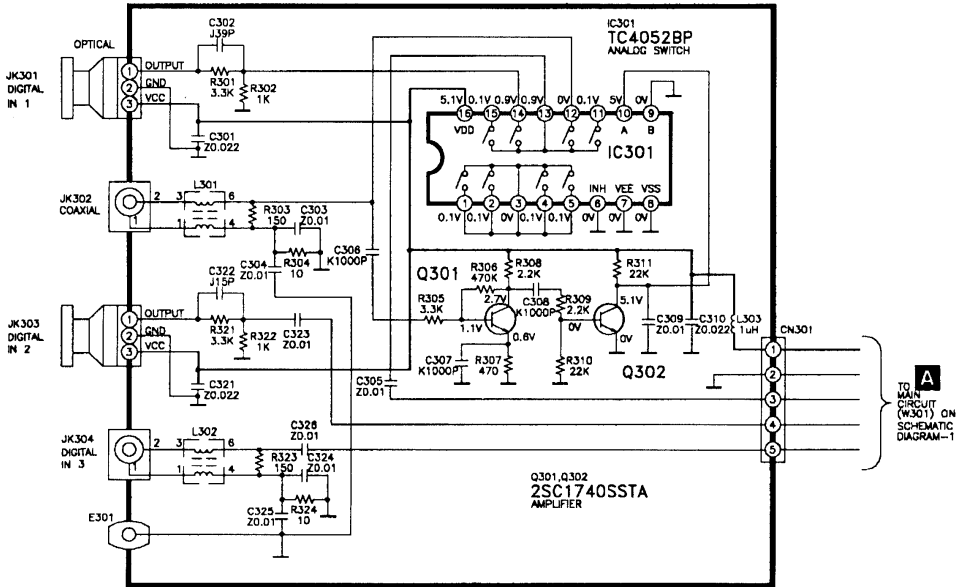

C VOLUME CONTROL CIRCUIT
(P.C.Board on page 35)

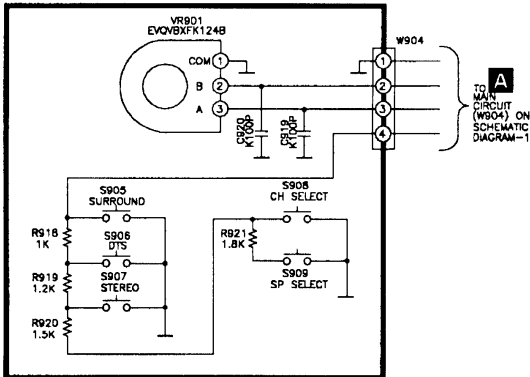

E POWER SWITCH CIRCUIT
(P.C.Board on page 34)

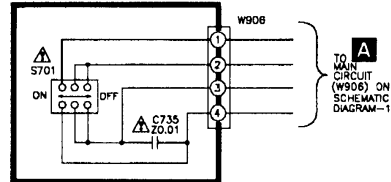

D CONTROL CIRCUIT
(P.C.Board on page 34)

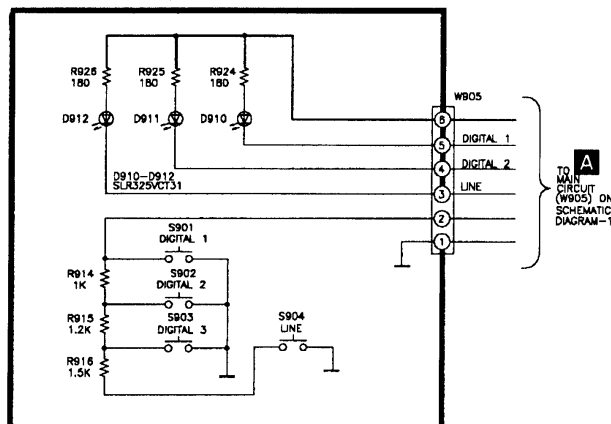

■ Printed Circuit Board (This printed circuit board diagram may be modified at any time with the development of new technology.)

H AC-3 MODULE UNIT P.C.B. (REP2703A-T)

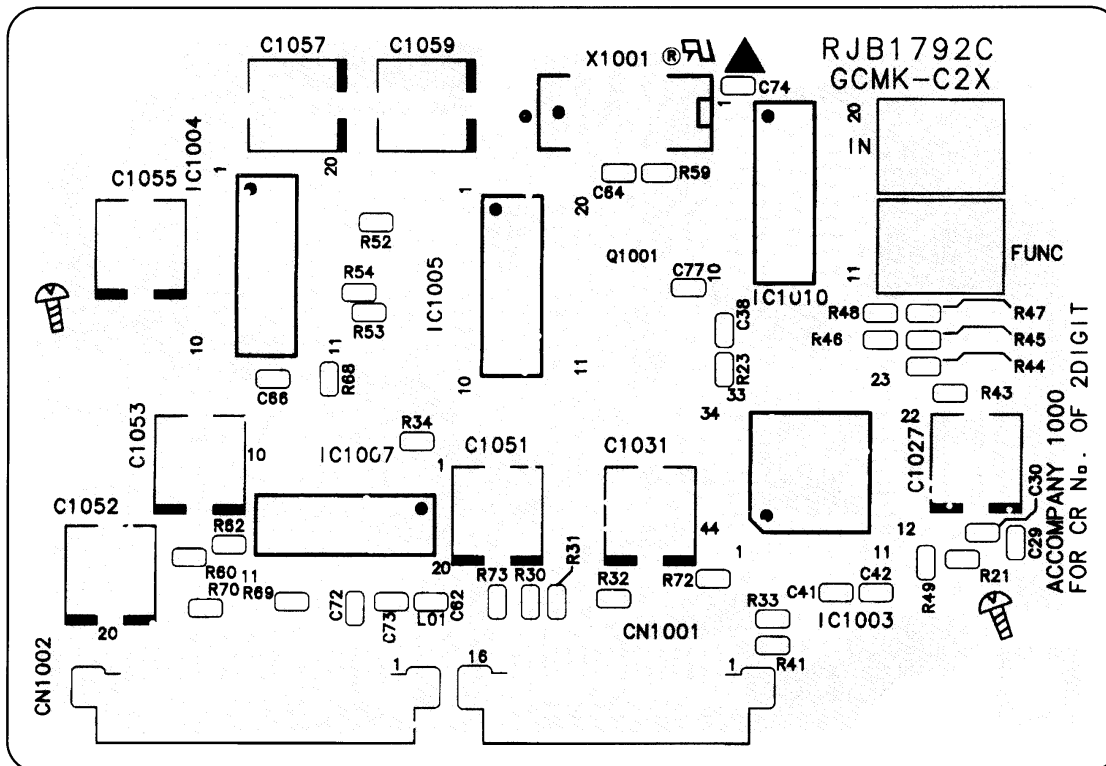
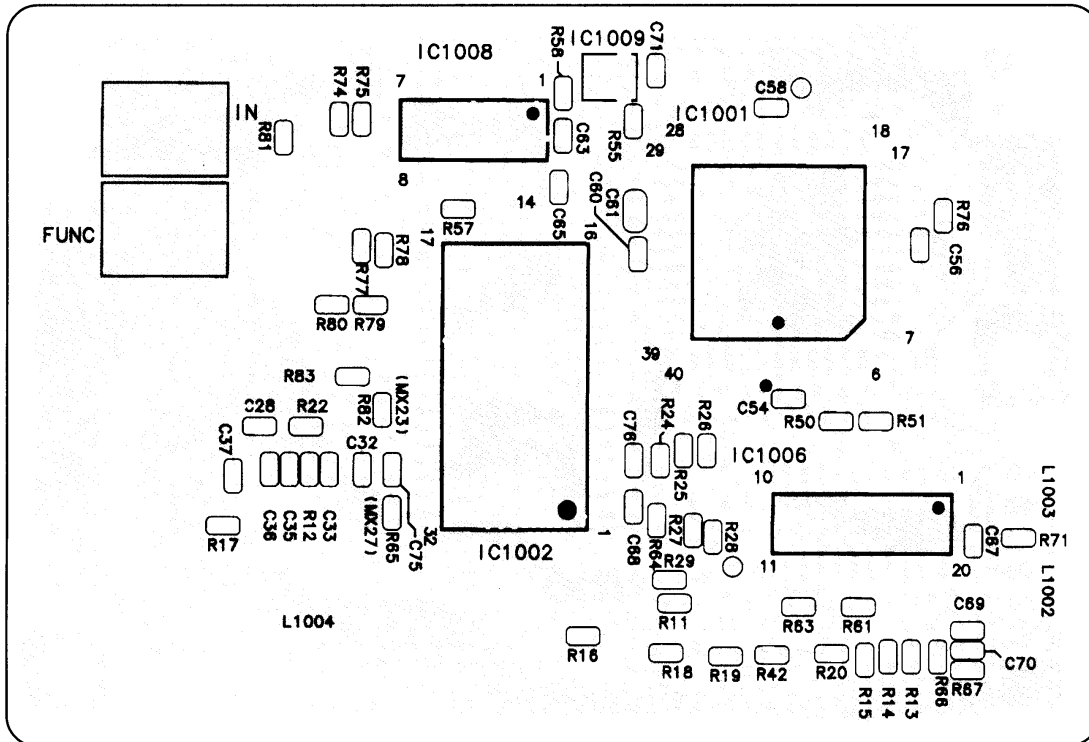

A B C D E F G H
A MAIN P.C.B. (REP2704C-M)

AC
230V
230-
50HZ

FRONT SPEAKERS SUBWFR/CNTR SPEAKERS SURROUND SPEAKERS FRONT SPEAKERS SUBWFR/CNTR SPEAKERS SURROUND SPEAKERS

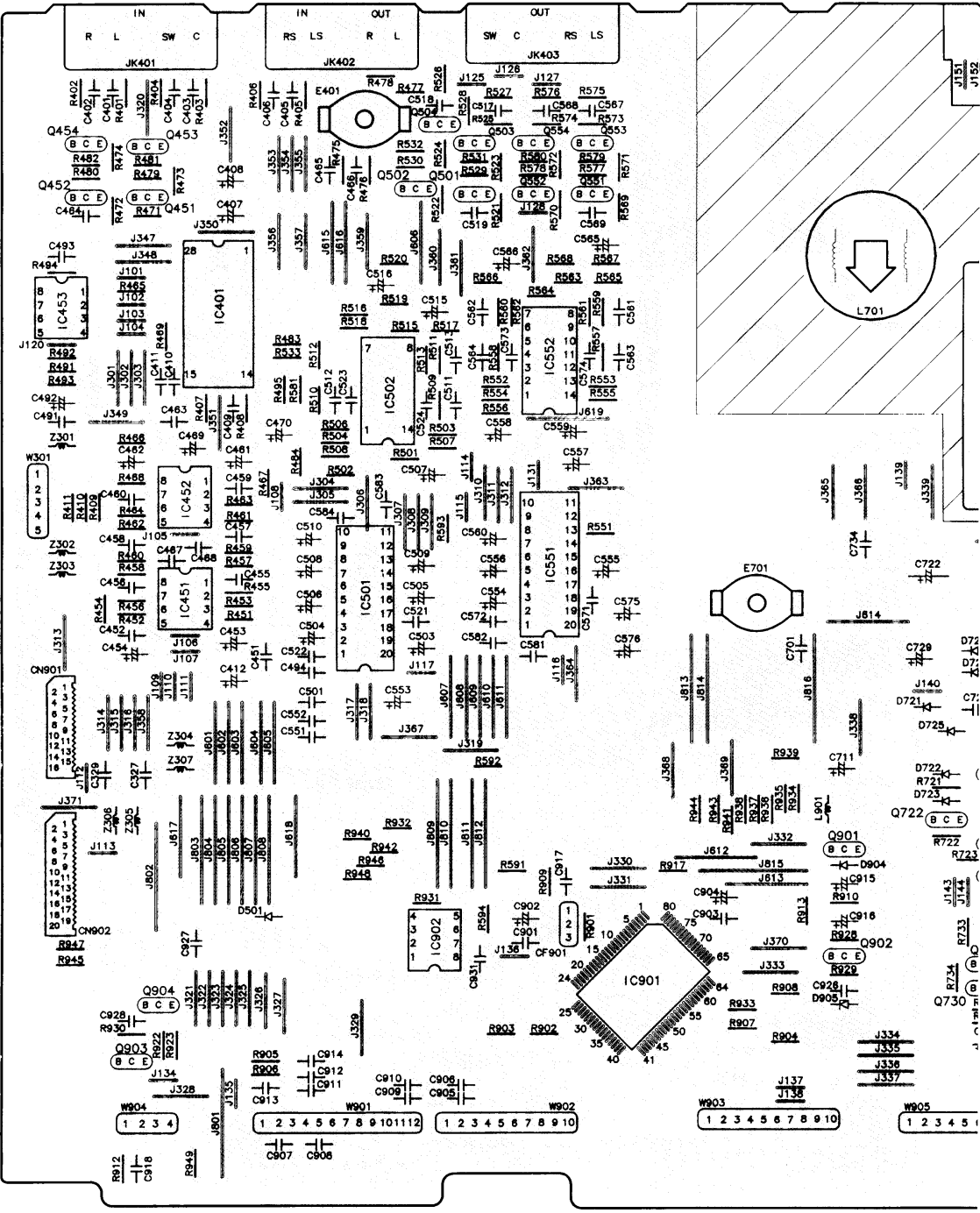

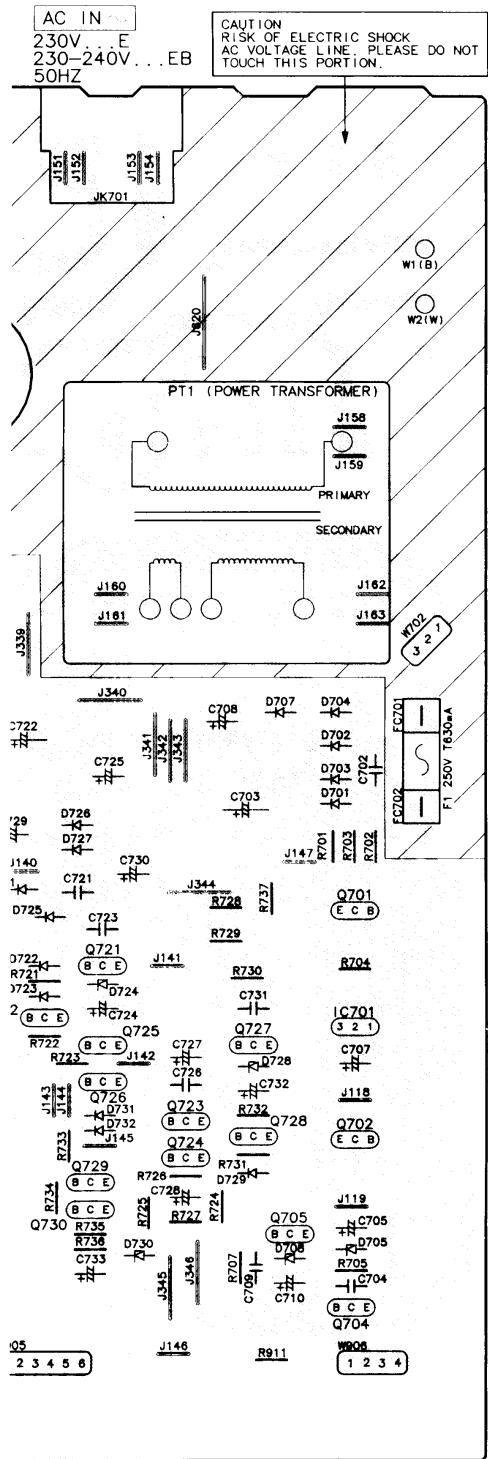
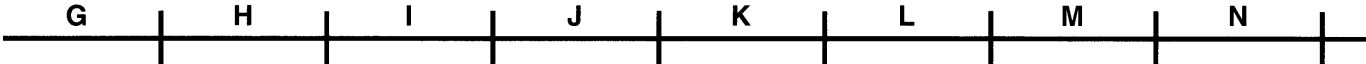

Parts Location Table

Ref No.	Loc. No.	Ref No.	Loc. No.
CF901	E8	Q501	D3
CN901	A6	Q502	D3
CN902	B8	Q503	D2
D701	I6	Q504	D2
D702	I6	Q551	E3
D703	I6	Q552	E3
D704	I5	Q553	E2
D705	I9	Q554	E2
D707	I5	Q701	I7
D721	G6	Q702	I8
D722	G7	Q704	I9
D723	G7	Q705	I9
D724	G7	Q721	H7
D725	G7	Q722	G7
D726	H6	Q723	H8
D727	H6	Q724	H8
D728	I8	Q725	H7
D729	I8	Q726	H8
D730	H9	Q727	I7
D731	H8	Q728	I8
D732	H8	Q729	H8
D904	G8	Q730	G9
D905	G9	Q901	G7
E401	C2	Q902	G8
E701	F6	Q903	B9
FC701	J6	Q904	B8
FC702	J6	W1	J3
IC401	B4	W2	J3
IC451	B6	W301	A5
IC452	B5	W702	J5
IC453	A4	W901	C9
IC501	C6	W902	E9
IC502	D4	W903	F9
IC551	E6	W904	B9
IC552	E4	W905	G9
IC701	I7	W906	I9
IC901	E8	Z301	A5
IC902	D8	Z302	A5
JK401	B2	Z303	A5
JK402	C2	Z304	B7
JK403	E2	Z305	B7
JK701	H2	Z306	B7
L701	G3	Z307	B7
L901	G7		
Q451	B3		
Q452	B3		
Q453	B2		
Q454	B2		

D CONTROL P.C.B. (REP2704C-M)

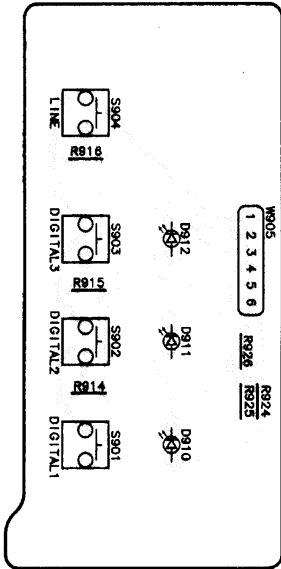

F DIGITAL INPUT P.C.B. (REP2705C-T)

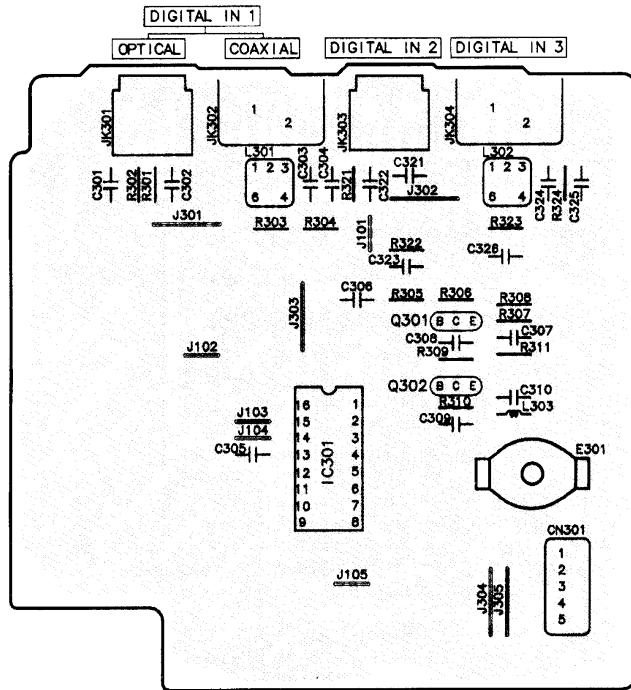

G SUB-TRANSFORMER P.C.B. (REP2705C-T)

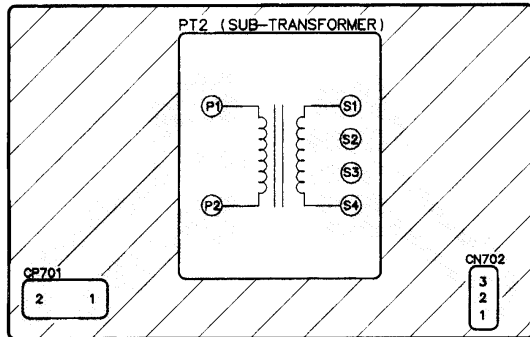

E POWER SWITCH P.C.B. (REP2704C-M)

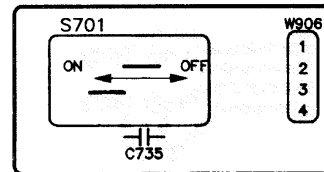

B DISPLAY P.C.B. (REP2704C-M)

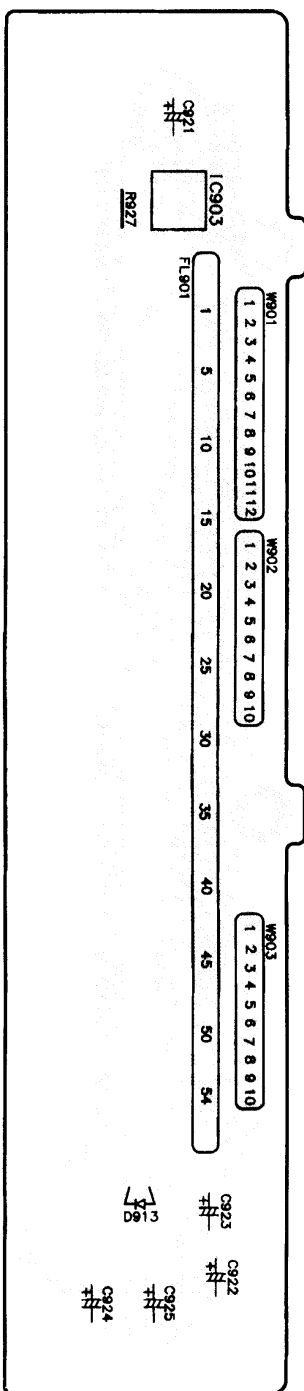

C VOLUME P.C.B. (REP2704C-M)

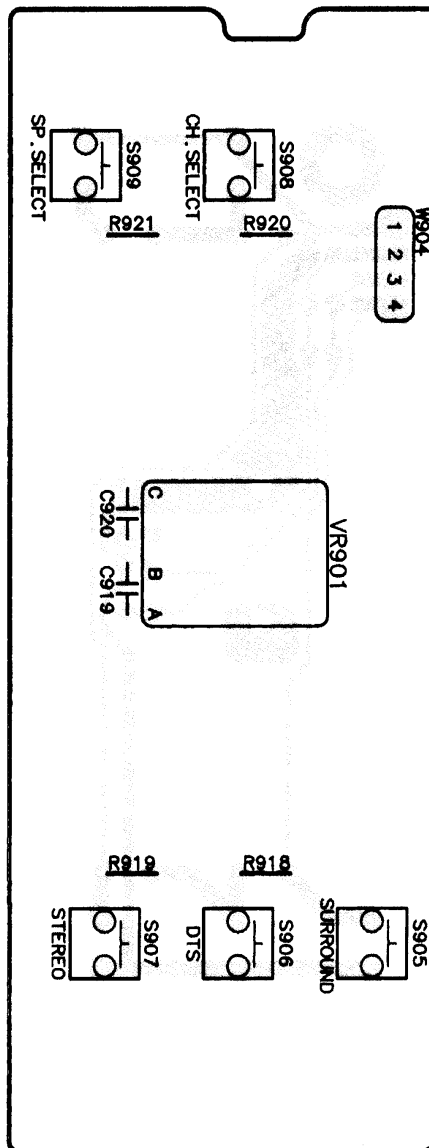

Cabinet Parts Location

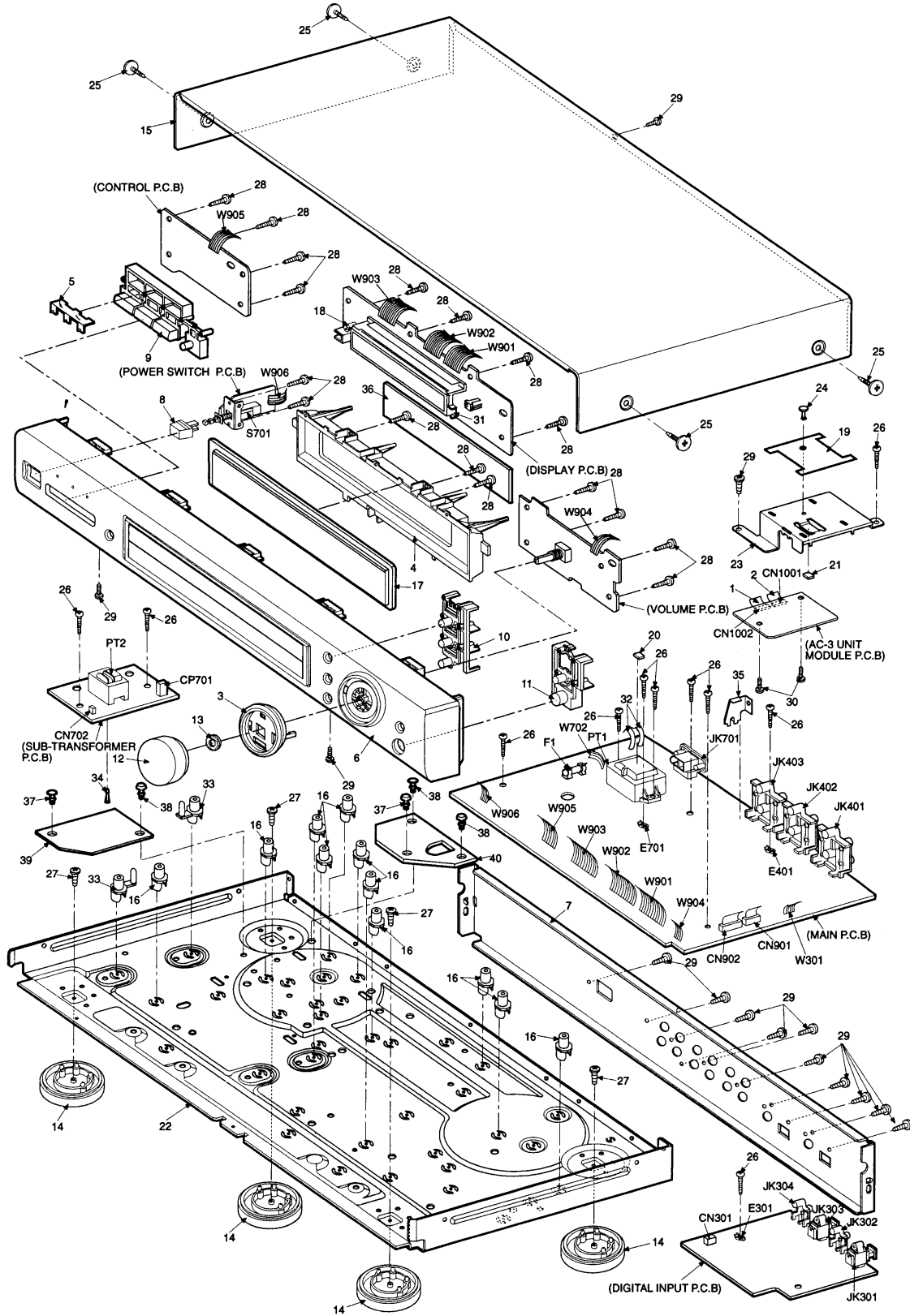

■ Replacement Parts List

Notes: * Important safety notice :

 Components identified by  mark have special characteristics important for safety.





















Furthermore, special parts which have purposes of fire-retardant (resistors), high-quality sound (capacitors), low-noise (resistors), etc. are used.

When replacing any of components, be sure to use only manufacturer's specified parts shown in the parts list.

* The parenthesized in the Remarks columns specify the areas. (Refer to the cover page for area.)

Parts without these indication can be used for all areas.

* [M] in Remarks column indicates parts that are supplied by MESA.

Ref No.	Part No.	Part Name & Description	Remarks	Ref No.	Part No.	Part Name & Description	Remarks	Ref No.	Part No.	Part Name & Description	Remarks
		CABINET AND CHASSIS		37	RMR1227-W	NYLON RIVET	[M]	Q501	2SD1915FTA	TRANSISTOR	[M]
				38	RMR1228-K	NYLON RIVET	[M]	Q502	2SD1915FTA	TRANSISTOR	[M]
1	REE0785-1	FFC	[M]	39	RMZ0501	BARRIER (A)	[M]	Q503	2SD1915FTA	TRANSISTOR	[M]
2	REE0786-1	FFC	[M]	40	RMZ0488	BARRIER	[M]	Q504	2SD1915FTA	TRANSISTOR	[M]
3	RGK0747-S	VOL RING	[M]					Q551	2SD1915FTA	TRANSISTOR	[M]
4	RGK0920-K	WINDOW STAGE	[M]			INTEGRATED CIRCUITS		Q552	2SD1915FTA	TRANSISTOR	[M]
5	RGL0369-Q	PANEL LIGHT	[M]					Q553	2SD1915FTA	TRANSISTOR	[M]
6	RFKAC500DEK	FRONT PANEL ASS'Y	[M]	IC301	TC4052BP	IC, ANALOG SW	[M]	Q554	2SD1915FTA	TRANSISTOR	[M]
7	RGR0181J-A	REAR PANEL	[M]E	IC401	TC9162AN	IC, SELECTOR	[M]	Q701	2SD2137PQTA	TRANSISTOR	[M]
7	RGR0181J-B	REAR PANEL	[M]EB	IC451	NJM4580DD	IC, OP AMP	[M]	Q702	2SD2137PQTA	TRANSISTOR	[M]
8	RGU0890-1K	BUTTON	[M]	IC452	NJM4580DD	IC, OP AMP	[M]	Q704	2SC1740SSTA	TRANSISTOR	[M] 
9	RGU1541A-2K	BUTTON (L)	[M]	IC453	NJM4580DD	IC, OP AMP	[M]	Q705	2SC1740SSTA	TRANSISTOR	[M] 
10	RGU1542-1K	BUTTON (C)	[M]	IC501	TC9212P	IC, CMOS	[M]	Q721	2SD592AQSTA	TRANSISTOR	[M] 
11	RGU1543-1K	BUTTON (R)	[M]	IC502	NJM2060D	IC, OP AMP	[M]	Q722	2SA933SSTA	TRANSISTOR	[M] 
12	RGW0229-K	KNOB	[M]	IC551	TC9212P	IC, CMOS	[M]	Q723	2SB621AQSTA	TRANSISTOR	[M] 
13	RHN90001	M9 NUT	[M]	IC552	NJM2060D	IC, OP AMP	[M]	Q724	2SA933SSTA	TRANSISTOR	[M] 
14	RKA0079-A	LEG UNIT	[M]	IC701	BA033T	IC, 3.3V REGULATOR	[M] 	Q725	RVTDTTC114YST	TRANSISTOR	[M]
15	RKM0032-K2J	TOP CABINET	[M]	IC901	M38B53M4057F	IC, MICOM	[M]	Q726	RVTDTA114YST	TRANSISTOR	[M]
16	RKQ0089-J	PCB HOLDER	[M]	IC902	BR93LC46	IC, EEPROM	[M]	Q727	2SA992FEPTA	TRANSISTOR	[M] 
17	RKW0518-Q	FL WINDOW	[M]	IC903	RCD12042TE	IC, REMOTE SENSOR	[M]	Q728	2SA933SSTA	TRANSISTOR	[M] 
18	RMN0447	LED SUPPORT	[M]	IC1001	CS4926-CL	IC, AC3	[M]	Q729	2SD1450RSTTA	TRANSISTOR	[M] 
19	RMA1098	HOLDING PLATE	[M]	IC1002	MX23C4000MC1	IC, MEMORY	[M]	Q730	2SD1450RSTTA	TRANSISTOR	[M] 
20	RMG0145	TRANSFORMER RUBBER	[M]	IC1003	CS4226-KQ	IC, DIR/DAC/VOL	[M]	Q901	RVTDTTC114YST	TRANSISTOR	[M]
21	RKW0519B-R	FL FILTER	[M]	IC1004	TC74VHC574FL	IC, OCTAL BUS BUFFER	[M]	Q902	2SA933SSTA	TRANSISTOR	[M] 
22	RMK0174-7	BOTTOM CHASSIS	[M]	IC1005	TC74VHC574FL	IC, OCTAL BUS BUFFER	[M]	Q903	RVTDTTC114YST	TRANSISTOR	[M]
23	RSC0482A	SHIELD	[M]	IC1006	TC74VHC244FL	IC, OCTAL BUS BUFFER	[M]	Q904	RVTDTA114YST	TRANSISTOR	[M]
24	SHR9112	PLASTIC RIVET	[M]	IC1007	TC74VHC244FL	IC, OCTAL BUS BUFFER	[M]			DIODES	
25	SNE2129-1	SCREW (CABINET)	[M]	IC1008	TC74VHC74FEL	IC, OCTAL BUS BUFFER	[M]				
26	XTB3+20JFZ	SCREW	[M]	IC1009	TC7SHU04F85L	IC, REGULATOR	[M] 	D501	RVD1SS133TA	DIODE	[M]
27	XTB3+6G	SCREW	[M]	IC1010	TC74VHC244FL	IC, OCTAL BUS BUFFER	[M]	D701	RL1N4003N02	DIODE	[M] 
28	XTBS26+10J	SCREW	[M]					D702	RL1N4003N02	DIODE	[M] 
29	XTBS3+8JFZ1	SCREW	[M]			TRANSISTORS		D703	RL1N4003N02	DIODE	[M] 
30	XYN26+C6	SCREW	[M]					D704	RL1N4003N02	DIODE	[M] 
31	RMN0372	FL HOLDER	[M]	Q301	2SC1740SSTA	TRANSISTOR	[M]	D705	MTZJ6R2CTA	DIODE	[M] 
32	REZ1122	WIRE	[M]	Q302	2SC1740SSTA	TRANSISTOR	[M]	D707	RL1N4003N02	DIODE	[M] 
33	RMN0392	PCB SUPPORT	[M]	Q451	2SD1915FTA	TRANSISTOR	[M]	D708	MTZJ6R2ATA	DIODE	[M] 
34	RMNX0019	LOCKING SUPPORT	[M]	Q452	2SD1915FTA	TRANSISTOR	[M]	D721	RL1N4003N02	DIODE	[M] 
35	RSC0382	SHIELD PLATE	[M]	Q453	2SD1915FTA	TRANSISTOR	[M]	D722	RVD1SS133TA	DIODE	[M]
36	RMV0181	DUST BARRIER	[M]	Q454	2SD1915FTA	TRANSISTOR	[M]				





Ref No.	Part No.	Part Name & Description	Remarks	Ref No.	Part No.	Part Name & Description	Remarks	Ref No.	Part No.	Part Name & Description	Remarks
D723	RVD1SS133TA	DIODE	[M]	L303	RLQZP1R0KT-Y	AXIAL COIL	[M]	JK403	SJF3069-18N	JK, RCA PIN	[M]
D724	MTZJ13BTA	DIODE	[M] △	L701	RLQZ271M	AC LINE COIL	[M] △	JK701	SJS9236-1	JK, AC INLET	[M] △
D725	RL1N4003N02	DIODE	[M] △	L901	RLQB101KTA-Y	CHOKE COIL	[M]				
D726	RL1N4003N02	DIODE	[M] △	L1001	RLQM2R2KT2-W	COIL	[M]			EARTH TERMINAL	
D727	RL1N4003N02	DIODE	[M] △	L1002	RLQM2R2KT2-W	COIL	[M]				
D728	MTZJ27DTA	DIODE	[M] △	L1003	RLQM2R2KT2-W	COIL	[M]	E301	SNE1004-2	EARTH TERMINAL	[M]
D729	RVD1SS133TA	DIODE	[M]	L1004	RLQM2R2KT2-W	COIL	[M]	E401	SNE1004-2	EARTH TERMINAL	[M]
D730	MTZJ4R7BTA	DIODE	[M] △	PT1	RTP1K4E034	POWER TRANSFORMER	[M] △	E701	SNE1004-2	EARTH TERMINAL	[M]
D731	RVD1SS133TA	DIODE	[M]	PT2	RTP114E003	POWER TRANSFORMER	[M] △				
D732	RVD1SS133TA	DIODE	[M]							WIRES	
D904	RVD1SS133TA	DIODE	[M]			COMPONENT COMBINATION					
D905	MTZJ3R9ATA	DIODE	[M] △					W301	RWJ1805100SQ	WIRE	[M]
D910	SLR325VCT31	DIODE	[M]	Z301	BL02RN2R62T4	EMI BEAD CORE	[M]	W702	RWJ1803140SQ	WIRE	[M]
D911	SLR325VCT31	DIODE	[M]	Z302	BL02RN2R62T4	EMI BEAD CORE	[M]	W901	RWJ1812170SS	WIRE	[M]
D912	SLR325VCT31	DIODE	[M]	Z303	BL02RN2R62T4	EMI BEAD CORE	[M]	W902	RWJ1810170SS	WIRE	[M]
D913	LN846RPH	DIODE	[M]	Z304	BL02RN2R62T4	EMI BEAD CORE	[M]	W903	RWJ1810170SS	WIRE	[M]
				Z305	BL02RN2R62T4	EMI BEAD CORE	[M]	W904	RWJ1804200SS	WIRE	[M]
		VARIABLE RESISTORS		Z306	BL02RN2R62T4	EMI BEAD CORE	[M]	W905	RWJ1806160SS	WIRE	[M]
				Z307	BL02RN2R62T4	EMI BEAD CORE	[M]	W906	RWJ1804160SS	4P WIRE	[M]
VR901	EVQVBXFK124B	VR, SWITCH	[M]								
		SWITCHES				CERAMIC FILTERS					
				CF901	RVCST4R00MT	CERAMIC OSCILLATOR	[M]				
S701	RSP2B023-A	SW, POWER	[M] △								
S901	EVQ21405R	SW, DIGITAL 1	[M]			OSCILLATORS					
S902	EVQ21405R	SW, DIGITAL 2	[M]								
S903	EVQ21405R	SW, DIGITAL 3	[M]	X1001	RSXB49M1S02T	XTAL OSC 49.152MHZ	[M]				
S904	EVQ21405R	SW, LINE IN	[M]								
S905	EVQ21405R	SW, SURROUND	[M]			DISPLAY TUBE					
S906	EVQ21405R	SW, DTS	[M]								
S907	EVQ21405R	SW, STEREO	[M]	FL901	RSL0262-F	FL	[M]				
S908	EVQ21405R	SW, CH. SELECT	[M]								
S909	EVQ21405R	SW, SPK. SELECT	[M]			FUSES					
				F1	XBA2C06TB0	FUSE	[M] △				
		CONNECTORS									
						FUSE HOLDERS					
CN301	RJS1A6605T1	CONNECTOR	[M]								
CN702	RJS1A6603T1	3P TAPING CONNECTOR	[M]	FC701	RJR0169T	FUSE HOLDER	[M]				
CN901	RJS2A3316	16P CONNECTOR	[M]	FC702	RJR0169T	FUSE HOLDER	[M]				
CN902	RJS2A3320	20P CONNECTOR	[M]								
CN1001	RJS2A4816T	16P CONNECTOR	[M]			JACKS					
CN1002	RJS2A4820T	20P CONNECTOR	[M]								
CP701	RJP1A4103	CONNECTOR	[M]	JK301	T0RX178A	JK, OPTICAL MODULE	[M]				
				JK302	SJFD7-8	JK, RCA PIN	[M]				
		COILS & TRANSFORMERS		JK303	T0RX178A	JK, OPTICAL MODULE	[M]				
				JK304	SJFD7-8	JK, RCA PIN	[M]				
L301	RLQZ150M-0	CHOKE COIL	[M]	JK401	SJF3069-19N	JK, RCA PIN	[M]				
L302	RLQZ150M-0	CHOKE COIL	[M]	JK402	SJF3069-4N	JK, LINE IN	[M]				

■ Resistors & Capacitors

- Notes :
- Important safety notice:
Components identified by \triangle mark have special characteristics important for safety.
Furthermore, special parts which have purposes of fire-retardant (resistors), high-quality sound (capacitors), low-noise (resistors), etc. are used.
When replacing any of components, be sure to use only manufacturer's specified parts shown in the parts list.
 - The parenthesized in the Remarks columns specify the areas. (Refer to the cover page for area.)
Parts without these indication can be used for all areas.
 - [M] in Remarks column indicates parts that are supplied by MESA.
 - Capacitor values are in microfarad (μ F) unless specified otherwise, P=Pico-farads (pF) F=Farads (F)
 - Resistors values are in ohms, unless specified otherwise, 1k=1,000(OHM), 1M=1,000k(OHM)

Ref No.	Part No.	Values & Remarks	Ref No.	Part No.	Values & Remarks	Ref No.	Part No.	Values & Remarks	Ref No.	Part No.	Values & Remarks
	RESISTORS		R462	ERDS2TJ472T	4.7K 1/4W [M]	R515	ERDS2TJ222T	2.2K 1/4W [M]	R571	ERDS2TJ331T	330 1/4W [M]
			R463	ERDS2TJ332T	3.3K 1/4W [M]	R516	ERDS2TJ182T	1.8K 1/4W [M]	R572	ERDS2TJ331T	330 1/4W [M]
R301	ERDS2TJ332T	3.3K 1/4W [M]	R464	ERDS2TJ332T	3.3K 1/4W [M]	R517	ERDS2TJ222T	2.2K 1/4W [M]	R573	ERDS2TJ473T	47K 1/4W [M]
R302	ERDS2TJ102T	1K 1/4W [M]	R465	ERDS2TJ224T	220K 1/4W [M]	R518	ERDS2TJ222T	2.2K 1/4W [M]	R574	ERDS2TJ473T	47K 1/4W [M]
R303	ERDS2TJ151T	150 1/4W [M]	R466	ERDS2TJ224T	220K 1/4W [M]	R519	ERDS2TJ224T	220K 1/4W [M]	R575	ERDS2TJ331T	330 1/4W [M]
R304	ERDS2TJ100T	10 1/4W [M]	R467	ERDS2TJ562T	5.6K 1/4W [M]	R520	ERDS2TJ224T	220K 1/4W [M]	R576	ERDS2TJ331T	330 1/4W [M]
R305	ERDS2TJ332T	3.3K 1/4W [M]	R468	ERDS2TJ562T	5.6K 1/4W [M]	R521	ERDS2TJ331T	330 1/4W [M]	R577	ERDS2TJ102T	1K 1/4W [M]
R306	ERDS2TJ474T	470K 1/4W [M]	R469	ERDS2TJ222T	2.2K 1/4W [M]	R522	ERDS2TJ331T	330 1/4W [M]	R578	ERDS2TJ102T	1K 1/4W [M]
R307	ERDS2TJ471T	470 1/4W [M]	R471	ERDS2TJ331T	330 1/4W [M]	R523	ERDS2TJ331T	330 1/4W [M]	R579	ERDS2TJ102T	1K 1/4W [M]
R308	ERDS2TJ222T	2.2K 1/4W [M]	R472	ERDS2TJ331T	330 1/4W [M]	R524	ERDS2TJ331T	330 1/4W [M]	R580	ERDS2TJ102T	1K 1/4W [M]
R309	ERDS2TJ222T	2.2K 1/4W [M]	R473	ERDS2TJ331T	330 1/4W [M]	R525	ERDS2TJ224T	220K 1/4W [M]	R581	ERDS2TJ272T	2.7K 1/4W [M]
R310	ERDS2TJ223T	22K 1/4W [M]	R474	ERDS2TJ331T	330 1/4W [M]	R526	ERDS2TJ224T	220K 1/4W [M]	R591	ERDS2TJ332T	3.3K 1/4W [M]
R311	ERDS2TJ223T	22K 1/4W [M]	R475	ERDS2TJ224T	220K 1/4W [M]	R527	ERDS2TJ331T	330 1/4W [M]	R592	ERDS2TJ332T	3.3K 1/4W [M]
R321	ERDS2TJ332T	3.3K 1/4W [M]	R476	ERDS2TJ224T	220K 1/4W [M]	R528	ERDS2TJ331T	330 1/4W [M]	R593	ERDS2TJ332T	3.3K 1/4W [M]
R322	ERDS2TJ102T	1K 1/4W [M]	R477	ERDS2TJ331T	330 1/4W [M]	R529	ERDS2TJ102T	1K 1/4W [M]	R594	ERDS2TJ332T	3.3K 1/4W [M]
R323	ERDS2TJ151T	150 1/4W [M]	R478	ERDS2TJ331T	330 1/4W [M]	R530	ERDS2TJ102T	1K 1/4W [M]	R701	ERDS1FVJ2R2T \triangle	2.2 1/2W [M]
R324	ERDS2TJ100T	10 1/4W [M]	R479	ERDS2TJ102T	1K 1/4W [M]	R531	ERDS2TJ102T	1K 1/4W [M]	R702	ERDS1FVJ2R2T \triangle	2.2 1/2W [M]
R401	ERDS2TJ471T	470 1/4W [M]	R480	ERDS2TJ102T	1K 1/4W [M]	R532	ERDS2TJ102T	1K 1/4W [M]	R703	ERDS1FVJ3R9T \triangle	3.9 1/2W [M]
R402	ERDS2TJ471T	470 1/4W [M]	R481	ERDS2TJ102T	1K 1/4W [M]	R533	ERDS2TJ474T	470K 1/4W [M]	R704	ERDS1FVJ3R9T \triangle	3.9 1/2W [M]
R403	ERDS2TJ471T	470 1/4W [M]	R482	ERDS2TJ102T	1K 1/4W [M]	R551	ERDS2TJ124T	120K 1/4W [M]	R705	ERDS2TJ392T	3.9K 1/4W [M]
R404	ERDS2TJ471T	470 1/4W [M]	R483	ERDS2TJ474T	470K 1/4W [M]	R552	ERDS2TJ124T	120K 1/4W [M]	R707	ERDS2TJ182T	1.8K 1/4W [M]
R405	ERDS2TJ471T	470 1/4W [M]	R484	ERDS2TJ332T	3.3K 1/4W [M]	R553	ERDS2TJ102T	1K 1/4W [M]	R721	ERDS2TJ561T	560 1/4W [M]
R406	ERDS2TJ471T	470 1/4W [M]	R491	ERDS2TJ101T	100 1/4W [M]	R554	ERDS2TJ102T	1K 1/4W [M]	R722	ERDS2TJ102T	1K 1/4W [M]
R407	ERDS2TJ102T	1K 1/4W [M]	R492	ERDS2TJ224T	220K 1/4W [M]	R555	ERDS2TJ332T	3.3K 1/4W [M]	R723	ERDS2TJ153T	15K 1/4W [M]
R408	ERDS2TJ102T	1K 1/4W [M]	R493	ERDS2TJ222T	2.2K 1/4W [M]	R556	ERDS2TJ332T	3.3K 1/4W [M]	R724	ERDS2TJ103T	10K 1/4W [M]
R409	ERDS2TJ103T	10K 1/4W [M]	R494	ERDS2TJ103T	10K 1/4W [M]	R557	ERDS2TJ224T	220K 1/4W [M]	R725	ERDS2TJ273T	27K 1/4W [M]
R410	ERDS2TJ103T	10K 1/4W [M]	R495	ERDS2TJ332T	3.3K 1/4W [M]	R558	ERDS2TJ224T	220K 1/4W [M]	R726	ERDS2TJ223T	22K 1/4W [M]
R411	ERDS2TJ103T	10K 1/4W [M]	R501	ERDS2TJ124T	120K 1/4W [M]	R559	ERDS2TJ562T	5.6K 1/4W [M]	R727	ERDS2TJ272T	2.7K 1/4W [M]
R451	ERDS2TJ224T	220K 1/4W [M]	R502	ERDS2TJ124T	120K 1/4W [M]	R560	ERDS2TJ562T	5.6K 1/4W [M]	R728	ERDS1FVJ102T \triangle	1K 1/2W [M]
R452	ERDS2TJ224T	220K 1/4W [M]	R503	ERDS2TJ102T	1K 1/4W [M]	R561	ERDS2TJ153T	15K 1/4W [M]	R729	ERDS1FVJ102T \triangle	1K 1/2W [M]
R453	ERDS2TJ822T	8.2K 1/4W [M]	R504	ERDS2TJ102T	1K 1/4W [M]	R562	ERDS2TJ153T	15K 1/4W [M]	R730	ERDS1FVJ102T \triangle	1K 1/2W [M]
R454	ERDS2TJ822T	8.2K 1/4W [M]	R506	ERDS2TJ820T	82 1/4W [M]	R563	ERDS2TJ222T	2.2K 1/4W [M]	R731	ERDS2TJ273T	27K 1/4W [M]
R455	ERDS2TJ102T	1K 1/4W [M]	R507	ERDS2TJ332T	3.3K 1/4W [M]	R564	ERDS2TJ222T	2.2K 1/4W [M]	R732	ERDS2TJ104T	100K 1/4W [M]
R456	ERDS2TJ102T	1K 1/4W [M]	R508	ERDS2TJ332T	3.3K 1/4W [M]	R565	ERDS2TJ222T	2.2K 1/4W [M]	R733	ERDS2TJ223T	22K 1/4W [M]
R457	ERDS2TJ223T	22K 1/4W [M]	R509	ERDS2TJ224T	220K 1/4W [M]	R566	ERDS2TJ222T	2.2K 1/4W [M]	R734	ERDS2TJ223T	22K 1/4W [M]
R458	ERDS2TJ223T	22K 1/4W [M]	R510	ERDS2TJ224T	220K 1/4W [M]	R567	ERDS2TJ224T	220K 1/4W [M]	R735	ERDS2TJ101T	100 1/4W [M]
R459	ERDS2TJ332T	3.3K 1/4W [M]	R511	ERDS2TJ562T	5.6K 1/4W [M]	R568	ERDS2TJ224T	220K 1/4W [M]	R736	ERDS2TJ101T	100 1/4W [M]
R460	ERDS2TJ332T	3.3K 1/4W [M]	R512	ERDS2TJ222T	2.2K 1/4W [M]	R569	ERDS2TJ331T	330 1/4W [M]	R737	ERDS1FVJ4R7T \triangle	4.7 1/2W [M]
R461	ERDS2TJ472T	4.7K 1/4W [M]	R513	ERDS2TJ153T	15K 1/4W [M]	R570	ERDS2TJ331T	330 1/4W [M]	R901	ERDS2TJ102T	1K 1/4W [M]

Ref No.	Part No.	Values & Remarks	Ref No.	Part No.	Values & Remarks	Ref No.	Part No.	Values & Remarks	Ref No.	Part No.	Values & Remarks
R902	ERDS2TJ102T	1K 1/4W [M]	R1011	ERJ3GEYJ102Z	1K 1/16W[M]	R1066	ERJ3GEYJ102Z	1K 1/16W[M]	C411	ECBT1H101KB5	100P 50V [M]
R903	ERDS2TJ102T	1K 1/4W [M]	R1012	ERJ3GEYJ104Z	100K 1/16W[M]	R1067	ERJ3GEYJ102Z	1K 1/16W[M]	C412	ECEA0JKA470B	47 6.3V [M]
R904	ERDS2TJ104T	100K 1/4W [M]	R1013	ERJ3GEYJ102Z	1K 1/16W[M]	R1068	ERJ3GEYJ330V	33 1/16W[M]	C451	ECBT1H471KB5	470P 50V [M]
R905	ERDS2TJ104T	100K 1/4W [M]	R1014	ERJ3GEYJ102Z	1K 1/16W[M]	R1069	ERJ3GEYJ102Z	1K 1/16W[M]	C452	ECBT1H471KB5	470P 50V [M]
R906	ERDS2TJ104T	100K 1/4W [M]	R1015	ERJ3GEYJ102Z	1K 1/16W[M]	R1070	ERJ3GEYJ102Z	1K 1/16W[M]	C453	ECA1EPXS100B	10 25V [M]
R907	ERDS2TJ104T	100K 1/4W [M]	R1016	ERJ3GEYJ102Z	1K 1/16W[M]	R1071	ERJ3GEYJ472V	4.7K 1/16W[M]	C454	ECA1EPXS100B	10 25V [M]
R908	ERDS2TJ103T	10K 1/4W [M]	R1017	ERJ3GEYJ102Z	1K 1/16W[M]	R1072	ERJ3GEYJ102Z	1K 1/16W[M]	C455	ECBT1H220J5	22P 50V [M]
R909	ERDS2TJ104T	100K 1/4W [M]	R1018	ERJ3GEYJ102Z	1K 1/16W[M]	R1073	ERJ3GEYJ102Z	1K 1/16W[M]	C456	ECBT1H220J5	22P 50V [M]
R910	ERDS2TJ472T	4.7K 1/4W [M]	R1019	ERJ3GEYJ102Z	1K 1/16W[M]	R1074	ERJ3GEYJ472V	4.7K 1/16W[M]	C457	ECFR1E222KR	2200P 25V [M]
R911	ERDS2TJ332T	3.3K 1/4W [M]	R1020	ERJ3GEYJ102Z	1K 1/16W[M]	R1075	ERJ3GEYJ472V	4.7K 1/16W[M]	C458	ECFR1E222KR	2200P 25V [M]
R912	ERDS2TJ104T	100K 1/4W [M]	R1021	ERJ3GEYJ473V	47K 1/16W[M]	R1076	ERJ3GEYJ472V	4.7K 1/16W[M]	C459	ECCR1H391J5	390P 50V [M]
R913	ERDS2TJ103T	10K 1/4W [M]	R1022	ERJ3GEYJ1R5V	1.5 1/16W[M]	R1077	ERJ3GEYJ472V	4.7K 1/16W[M]	C460	ECCR1H391J5	390P 50V [M]
R914	ERDS2TJ102T	1K 1/4W [M]	R1023	ERJ3GEYJ102Z	1K 1/16W[M]	R1078	ERJ3GEYJ472V	4.7K 1/16W[M]	C461	ECA1EPXS100B	10 25V [M]
R915	ERDS2TJ122T	1.2K 1/4W [M]	R1024	ERJ3GEYJ101V	100 1/16W[M]	R1079	ERJ3GEYJ472V	4.7K 1/16W[M]	C462	ECA1EPXS100B	10 25V [M]
R916	ERDS2TJ152T	1.5K 1/4W [M]	R1025	ERJ3GEYJ101V	100 1/16W[M]	R1080	ERJ3GEYJ472V	4.7K 1/16W[M]	C463	ECQV1H224JZ3	0.22 50V [M]
R917	ERDS2TJ103T	10K 1/4W [M]	R1026	ERJ3GEYJ101V	100 1/16W[M]	R1081	ERJ3GEYJ472V	4.7K 1/16W[M]	C464	ECBT1E103ZF5	0.01 25V [M]
R918	ERDS2TJ102T	1K 1/4W [M]	R1027	ERJ3GEYJ101V	100 1/16W[M]	R1083	ERJ3GEYJ101V	100 1/16W[M]	C465	ECBT1H102KB5	1000P 50V [M]
R919	ERDS2TJ122T	1.2K 1/4W [M]	R1028	ERJ3GEYJ101V	100 1/16W[M]				C466	ECBT1H102KB5	1000P 50V [M]
R920	ERDS2TJ152T	1.5K 1/4W [M]	R1029	ERJ3GEYJ101V	100 1/16W[M]				C467	ECBT1E103ZF5	0.01 25V [M]
R921	ERDS2TJ182T	1.8K 1/4W [M]	R1030	ERJ3GEYJ470V	47K 1/16W[M]				C468	ECBT1E103ZF5	0.01 25V [M]
R922	ERDS2TJ473T	47K 1/4W [M]	R1031	ERJ3GEYJ470V	47K 1/16W[M]	C301	ECBT1E223ZF5	0.022 25V [M]	C469	ECA1EPXS100B	10 25V [M]
R923	ERDS2TJ473T	47K 1/4W [M]	R1032	ERJ3GEYJ470V	47K 1/16W[M]	C302	ECBT1H390J5	39P 50V [M]	C470	ECA1EPXS100B	10 25V [M]
R924	ERDS2TJ181T	180 1/4W [M]	R1033	ERJ3GEYJ102Z	1K 1/16W[M]	C303	ECBT1E103ZF5	0.01 25V [M]	C491	ECBT1H102KB5	1000P 50V [M]
R925	ERDS2TJ181T	180 1/4W [M]	R1034	ERJ3GEYJ330V	33 1/16W[M]	C304	ECBT1E103ZF5	0.01 25V [M]	C492	ECA1HPXS4R7B	4.7 50V [M]
R926	ERDS2TJ181T	180 1/4W [M]	R1041	ERJ3GEYJ102Z	1K 1/16W[M]	C305	ECBT1E103ZF5	0.01 25V [M]	C493	ECFR1E333KR	0.033 25V [M]
R927	ERDS2TJ181T	180 1/4W [M]	R1042	ERJ3GEYJ102Z	1K 1/16W[M]	C306	ECBT1H102KB5	1000P 50V [M]	C494	ECQV1H823JZ3	0.082 50V [M]
R928	ERDS2TJ271T	270 1/4W [M]	R1043	ERJ3GEYJ102Z	1K 1/16W[M]	C307	ECBT1H102KB5	1000P 50V [M]	C501	ECBT1H102KB5	1000P 50V [M]
R929	ERDS2TJ121T	120 1/4W [M]	R1044	ERJ3GEYJ102Z	1K 1/16W[M]	C308	ECBT1H102KB5	1000P 50V [M]	C503	ECA1HPXS4R7B	4.7 50V [M]
R930	ERDS2TJ473T	47K 1/4W [M]	R1045	ERJ3GEYJ102Z	1K 1/16W[M]	C309	ECBT1E103ZF5	0.01 25V [M]	C504	ECA1HPXS4R7B	4.7 50V [M]
R931	ERDS2TJ104T	100K 1/4W [M]	R1046	ERJ3GEYJ102Z	1K 1/16W[M]	C310	ECBT1E223ZF5	0.022 25V [M]	C505	ECA1HPXS4R7B	4.7 50V [M]
R932	ERDS2TJ101T	100 1/4W [M]	R1047	ERJ3GEYJ102Z	1K 1/16W[M]	C321	ECBT1E223ZF5	0.022 25V [M]	C506	ECA1HPXS4R7B	4.7 50V [M]
R933	ERDS2TJ101T	100 1/4W [M]	R1048	ERJ3GEYJ102Z	1K 1/16W[M]	C322	ECBT1H150J5	15P 50V [M]	C507	ECA1EPXS100B	10 25V [M]
R934	ERDS2TJ101T	100 1/4W [M]	R1049	ERJ3GEYJ100V	10 1/16W[M]	C323	ECBT1E103ZF5	0.01 25V [M]	C508	ECA1EPXS100B	10 25V [M]
R935	ERDS2TJ101T	100 1/4W [M]	R1050	ERJ3GEYJ472V	4.7K 1/16W[M]	C324	ECBT1E103ZF5	0.01 25V [M]	C509	ECA1HPXS4R7B	4.7 50V [M]
R936	ERDS2TJ101T	100 1/4W [M]	R1051	ERJ3GEYJ472V	4.7K 1/16W[M]	C325	ECBT1E103ZF5	0.01 25V [M]	C510	ECA1HPXS4R7B	4.7 50V [M]
R937	ERDS2TJ101T	100 1/4W [M]	R1052	ERJ3GEYJ472V	4.7K 1/16W[M]	C326	ECBT1E103ZF5	0.01 25V [M]	C511	ECCR1H331J5	330P 50V [M]
R938	ERDS2TJ101T	100 1/4W [M]	R1053	ERJ3GEYJ472V	4.7K 1/16W[M]	C327	ECBT1H220J5	22P 50V [M]	C512	ECFR1E223KR	0.022 25V [M]
R939	ERDS2TJ101T	100 1/4W [M]	R1054	ERJ3GEYJ472V	4.7K 1/16W[M]	C329	ECBT1H101KB5	100P 50V [M]	C513	ECCR1H331J5	330P 50V [M]
R940	ERDS2TJ101T	100 1/4W [M]	R1055	ERJ3GEYJ330V	33 1/16W[M]	C401	ECBT1H221KB5	220P 50V [M]	C515	ECA1EPXS100B	10 25V [M]
R941	ERDS2TJ104T	100K 1/4W [M]	R1057	ERJ3GEYJ330V	33 1/16W[M]	C402	ECBT1H221KB5	220P 50V [M]	C516	ECA1EPXS100B	10 25V [M]
R942	ERDS2TJ101T	100 1/4W [M]	R1058	ERJ3GEY0R00V	0 1/16W[M]	C403	ECBT1H221KB5	220P 50V [M]	C517	ECBT1H102KB5	1000P 50V [M]
R943	ERDS2TJ101T	100 1/4W [M]	R1059	ERJ3GEYJ330V	33 1/16W[M]	C404	ECBT1H221KB5	220P 50V [M]	C518	ECBT1H102KB5	1000P 50V [M]
R944	ERDS2TJ101T	100 1/4W [M]	R1060	ERJ3GEYJ102Z	1K 1/16W[M]	C405	ECBT1H221KB5	220P 50V [M]	C519	ECBT1E103ZF5	0.01 25V [M]
R945	ERDS2TJ101T	100 1/4W [M]	R1061	ERJ3GEYJ104Z	100K 1/16W[M]	C406	ECBT1H221KB5	220P 50V [M]	C521	ECBT1E103ZF5	0.01 25V [M]
R946	ERDS2TJ101T	100 1/4W [M]	R1062	ERJ3GEYJ102Z	1K 1/16W[M]	C407	ECA1HPXS4R7B	4.7 50V [M]	C522	ECBT1E103ZF5	0.01 25V [M]
R947	ERDS2TJ101T	100 1/4W [M]	R1063	ERJ3GEYJ104Z	100K 1/16W[M]	C408	ECA1HPXS4R7B	4.7 50V [M]	C523	ECBT1E103ZF5	0.01 25V [M]
R948	ERDS2TJ101T	100 1/4W [M]	R1064	ERJ3GEYJ103Z	10K 1/16W[M]	C409	ECBT1H101KB5	100P 50V [M]	C524	ECBT1E103ZF5	0.01 25V [M]
R949	ERDS2TJ101T	100 1/4W [M]	R1065	ERJ3GEYJ103Z	10K 1/16W[M]	C410	ECBT1H101KB5	100P 50V [M]	C551	ECBT1H102KB5	1000P 50V [M]

Ref No.	Part No.	Values & Remarks	Ref No.	Part No.	Values & Remarks	Ref No.	Part No.	Values & Remarks	Ref No.	Part No.	Values & Remarks
C552	ECBT1H102KB5	1000P 50V [M]	C731	ECKR1H103ZF5	0.01 50V [M]	C1052	ECEV0JA101P	100P 6.3V [M]			
C553	ECA1HPXS4R7B	4.7 50V [M]	C732	ECEA1VKA100B	10 35V [M]	C1053	ECEV0JA101P	100P 6.3V [M]			
C554	ECA1HPXS4R7B	4.7 50V [M]	C733	ECEA1VKA100B	10 35V [M]	C1054	ECUVNC104ZFV	0.1 16V [M]			
C555	ECA1HPXS4R7B	4.7 50V [M]	C734	ECBT1H104ZF5 	0.1 50V [M]	C1055	ECEV0JA101P	100P 6.3V [M]			
C556	ECA1HPXS4R7B	4.7 50V [M]	C735	ECBT1E103ZF5 	0.01 25V [M]	C1056	ECUVNC104ZFV	0.1 16V [M]			
C557	ECA1EPXS100B	10 25V [M]	C901	ECBT1H104ZF5	0.1 50V [M]	C1057	ECEV0JA101P	100P 6.3V [M]			
C558	ECA1EPXS100B	10 25V [M]	C902	ECEA0JKA101B	100 6.3V [M]	C1058	ECUVNC104ZFV	0.1 16V [M]			
C559	ECA1HPXS4R7B	4.7 50V [M]	C903	ECBT1E103ZF5	0.01 25V [M]	C1059	ECEV0JA101P	100P 6.3V [M]			
C560	ECA1HPXS4R7B	4.7 50V [M]	C904	ECEA0JKA101B	100 6.3V [M]	C1060	ECUVNC104ZFV	0.1 16V [M]			
C561	ECCR1H331J5	330P 50V [M]	C905	ECBT1H331KB5	330P 50V [M]	C1061	ECUVNC224KBN	0.22 16V [M]			
C562	ECCR1H331J5	330P 50V [M]	C906	ECBT1H331KB5	330P 50V [M]	C1062	ECUVNC104ZFV	0.1 16V [M]			
C563	ECCR1H331J5	330P 50V [M]	C907	ECBT1H331KB5	330P 50V [M]	C1063	ECUVNC104ZFV	0.1 16V [M]			
C564	ECCR1H331J5	330P 50V [M]	C908	ECBT1H331KB5	330P 50V [M]	C1064	ECUVNC104ZFV	0.1 16V [M]			
C565	ECA1EPXS100B	10 25V [M]	C909	ECBT1H331KB5	330P 50V [M]	C1065	ECUVNC104ZFV	0.1 16V [M]			
C566	ECA1EPXS100B	10 25V [M]	C910	ECBT1H331KB5	330P 50V [M]	C1066	ECUVNC104ZFV	0.1 16V [M]			
C567	ECBT1H102KB5	1000P 50V [M]	C911	ECBT1H331KB5	330P 50V [M]	C1067	ECUVNC104ZFV	0.1 16V [M]			
C568	ECBT1H102KB5	1000P 50V [M]	C912	ECBT1H331KB5	330P 50V [M]	C1068	ECUVNC104ZFV	0.1 16V [M]			
C569	ECBT1E103ZF5	0.01 25V [M]	C913	ECBT1H331KB5	330P 50V [M]	C1069	ECUV1H102KBV	1000P 50V [M]			
C571	ECBT1E103ZF5	0.01 25V [M]	C914	ECBT1H331KB5	330P 50V [M]	C1070	ECUV1H102KBV	1000P 50V [M]			
C572	ECBT1E103ZF5	0.01 25V [M]	C915	ECEA1HKA010B	1 50V [M]	C1071	ECUVNC104ZFV	0.1 16V [M]			
C573	ECBT1E103ZF5	0.01 25V [M]	C916	ECEA1HKA010B	1 50V [M]	C1072	ECUV1H101JCV	100P 50V [M]			
C574	ECBT1E103ZF5	0.01 25V [M]	C917	ECBT1E103ZF5	0.01 25V [M]	C1073	ECUV1H101JCV	100P 50V [M]			
C575	ECA1EPXS100B	10 25V [M]	C918	ECBT1E103ZF5	0.01 25V [M]	C1074	ECUVNC104ZFV	0.1 16V [M]			
C576	ECA1EPXS100B	10 25V [M]	C919	ECBT1H101KB5	100P 50V [M]	C1075	ECUV1H102KBV	1000P 50V [M]			
C581	ECBT1H101KB5	100P 50V [M]	C920	ECBT1H101KB5	100P 50V [M]	C1076	ECUV1H102KBV	1000P 50V [M]			
C582	ECBT1H101KB5	100P 50V [M]	C921	ECEA1CKA100B	10 16V [M]	C1077	ECUV1H101JCV	100P 50V [M]			
C583	ECBT1H101KB5	100P 50V [M]	C922	ECEA1VKA220B	22 35V [M]						
C584	ECBT1H101KB5	100P 50V [M]	C923	ECEA1VKA220B	22 35V [M]						
C701	ECBT1H104ZF5	0.1 50V [M]	C924	ECEA1VKA220B	22 35V [M]						
C702	ECBT1H104ZF5	0.1 50V [M]	C925	ECEA1VKA220B	22 35V [M]						
C703	ECEA1CU472E 	4700 16V [M]	C926	ECBT1E103ZF5	0.01 25V [M]						
C704	ECBT1E103ZF5	0.01 25V [M]	C927	ECBT1E103ZF5	0.01 25V [M]						
C705	ECEA1CKA100B	10 16V [M]	C928	ECBT1H104ZF5	0.1 50V [M]						
C707	ECEA1HKA010B	1 50V [M]	C931	ECBT1E103ZF5	0.01 25V [M]						
C708	ECA1CM471B	470 16V [M]	C1027	ECEV0JA101P	100P 6.3V [M]						
C709	ECBT1E103ZF5	0.01 25V [M]	C1028	ECUVNC104ZFV	0.1 16V [M]						
C710	ECEA0JKA470B	47 6.3V [M]	C1029	ECUV1E103KBV	0.01 25V [M]						
C711	ECEA0JKA470B	47 6.3V [M]	C1030	ECUV1H152KBV	1500P 50V [M]						
C721	ECBT1E103ZF5	0.01 25V [M]	C1031	ECEV0JA101P	100P 6.3V [M]						
C722	ECA1VPXS102E 	1000 35V [M]	C1032	ECUVNC104ZFV	0.1 16V [M]						
C723	ECKR1H103ZF5	0.01 50V [M]	C1033	ECUV1H101JCV	100P 50V [M]						
C724	ECEA1CKA220B	22 16V [M]	C1035	ECUV1H101JCV	100P 50V [M]						
C725	ECA1VPXS471E	470 35V [M]	C1036	ECUV1H102KBV	1000P 50V [M]						
C726	ECKR1H103ZF5	0.01 50V [M]	C1037	ECUV1H102KBV	1000P 50V [M]						
C727	ECEA1CKA100B	10 16V [M]	C1038	ECUV1H102KBV	1000P 50V [M]						
C728	ECEA1CKA100B	10 16V [M]	C1041	ECUV1H102KBV	1000P 50V [M]						
C729	ECA1VM101B 	100 35V [M]	C1042	ECUV1H102KBV	1000P 50V [M]						
C730	ECA1JM101B	01 6.3V [M]	C1051	ECEV0JA101P	100P 6.3V [M]						

■ Packing Materials & Accessories

Notes :

- * Important safety notice : Components identified by \triangle mark have special characteristics important for safety. Furthermore, special parts which have purposes of fire-retardant (resistors), high-quality sound (capacitors), low-noise (resistors), etc. are used. When replacing any of components, be sure to use only manufacturer's specified parts shown in the parts list.
- * The parenthesized in the Remarks columns specify the areas. (Refer to the cover page for area.)
- * Parts without these indication can be used for all areas.
- * The " (SF) " mark denotes standard part.
- * [M] in Remarks column indicates parts supplied by **MESA**.
- * Remote Control Unit : Supply period for three years from termination of production.
- * Reference for O/I book languages are as follows :

Ar : Arabic	Cf : Canadian French	Co : Chinese (old)	Cn : Chinese (new)	Cz : Czech	Da : Danish
Du : Dutch	En : English	Fr : French	Ge : German	It : Italian	Ko : Korean
Po : Polish	Ru : Russian	Sp : Spanish	Sw : Swedish		

Ref No.	Part No.	Part Name & Description	Remarks	Ref No.	Part No.	Part Name & Description	Remarks	Ref No.	Part No.	Part Name & Description	Remarks
		PACKING MATERIALS				ACCESSORIES		A6	RQT5023-E	O/I (En/Sp/Sw/Po/Cz/Ru)	[M]E
								A6	RQT5024-D	O/I BOOK (Ge/It/Fr)	[M]E
P1	RPG4464	PACKING CASE	[M]E	A1	EUR645410	REMOTE CONTROL	[M]	A6	RQT5025-H	O/I BOOK (Du/Da)	[M]E
P1	RPG4465	PACKING CASE	[M]EB	A1-1	UR64EC1822H	R/C BATTERY COVER	[M]	A6	RQT5026-B	O/I BOOK (En)	[M]EB
P2	RPN1058	POLYFOAM	[M]	A2	RJA0019-2K	AC CORD (SF) \triangle	[M]E				
P3	SPP740-1	BAG	[M]	A2	VJA0733	AC CORD (SF) \triangle	[M]EB				
P4	RPN1078	CUSHION	[M]EB	A3	SJP2281	OPTICAL CABLE	[M]				
				A4	RJL1P021B08	1P CORD	[M]				
				A5	RJL2P004B08A	STEREO CABLE	[M]				

■ Packaging

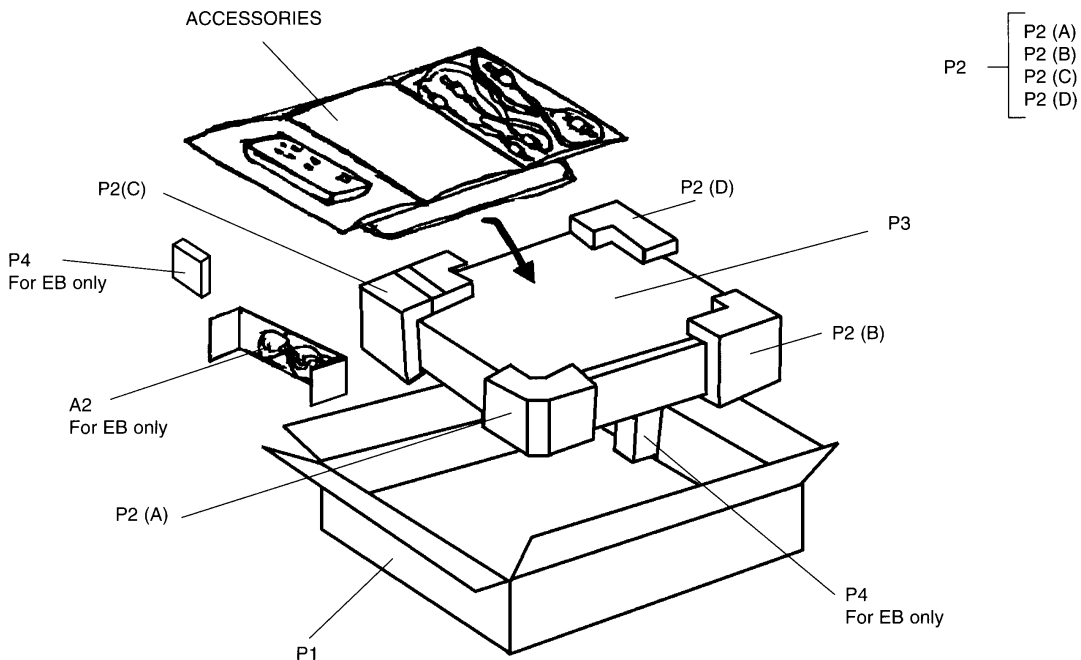

MESA Printed in Singapore
G990605700P/M/K/J/S