

Service Manual

Sound Processor



SH-EH580EG

Colour

(N)..... Gold Type

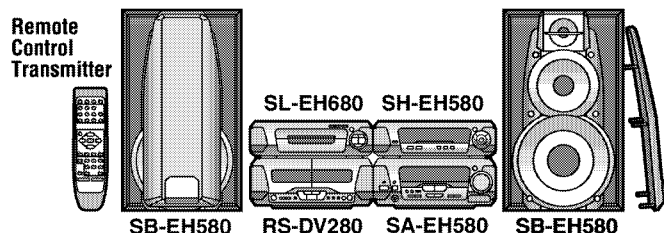

Because of unique interconnecting cables, when a component requires service, send or bring in the entire system.

System	SC-EH580
Sound Processor	SH-EH580
Tuner/Amplifier	SA-EH580
CD Player	SL-EH680
Cassette Deck	RS-DV280
Front Speakers*	SB-EH580

* : Made in Spain.

Specifications

EQ/SFP section

MANUAL GEQ:

5-Band EQ

Center frequency; 70 Hz, 300 Hz, 1 kHz, 3.15 kHz, 10 kHz

Level control; $\pm 2, 4, 6$ dB

EQ mode:

3 modes; HEAVY, CLEAR, SOFT

Pre-amplifier section

Input sensitivity/impedance:

AUX; 250 mV/15 k Ω

DSP control section

DSP control mode: SUPER SOUND EQ

Spectrum analyzer section

Display mode: NORMAL, PEAKHOLD, AURORA

General

Dimensions (W×H×D): 293×89×269 mm

Mass: 1.4 kg

Notes: Specifications are subject to change without notice.
Mass and dimensions are approximate.

Manufactured under license from Dolby Laboratories.
"Dolby", "Pro Logic" and the double-D symbol are trademarks of Dolby Laboratories.

WARNING

This service information is designed for experienced repair technicians only and is not designed for use by the general public. It does not contain warnings or cautions to advise non-technical individuals of potential dangers in attempting to service a product. Products powered by electricity should be serviced or repaired only by experienced professional technicians. Any attempt to service or repair the product or products dealt with in this service information by anyone else could result in serious injury or death.

Technics

© 2002 Matsushita Electric Industrial Co., Ltd. All rights reserved. Unauthorized copying and distribution is a violation of law.

CONTENTS

	Page		Page
1 Note	2	7 Printed Circuit Board Diagram	11
2 Location of Controls	2	8 Type Illustration of ICs, Transistors and Diodes	13
3 Operation Checks and Component Replacement Procedures	3	9 Wiring Connection Diagram	13
3.1. Checking for the FL P.C.B.	3	10 Block Diagram	15
3.2. Checking for the main P.C.B.	3	11 Terminal Function of ICs	17
4 To Supply Power Source	5	11.1. IC601 (C2BBGF000269):System Control/FL Drive	17
5 Schematic Diagram Notes	5	12 Replacement Parts List	18
6 Schematic Diagram	7	13 Cabinet Parts Location	21

1 Note

Refer to the service manual for Model No. SA-EH580 (Order No. AD0202023C2) for information on Accessories and Packaging.

2 Location of Controls

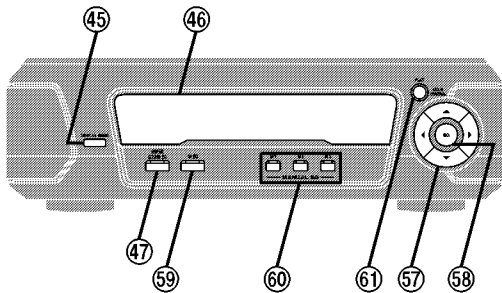

- ④⑤ Display mode button (DISPLAY MODE)
- ④⑥ Display
- ④⑦ Super sound EQ button (SUPER SOUND EQ)
- ④⑦ Multi control buttons
(◀, ▶, ▲, ▼, MULTI CONTROL)
- ④⑧ EQ button (EQ)
- ④⑨ AI EQ button (AI EQ)
- ④⑩ Manual EQ button (M1, M2, M3)
- ④⑪ Flat button (FLAT)

3 Operation Checks and Component Replacement Procedures

- This section describes procedures for checking the operation of the major printed circuit boards and replacing the main components.
- For reassembly after operation checks or replacement, reverse the respective procedures. Special reassembly procedures are described only when required.

3.1. Checking for the FL P.C.B.

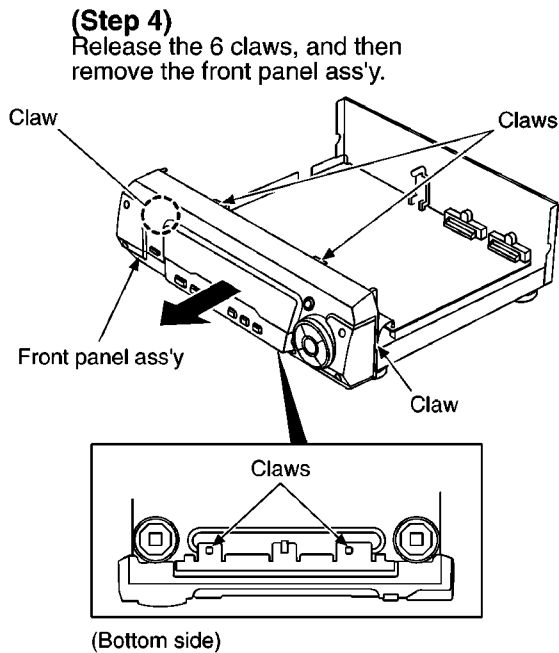
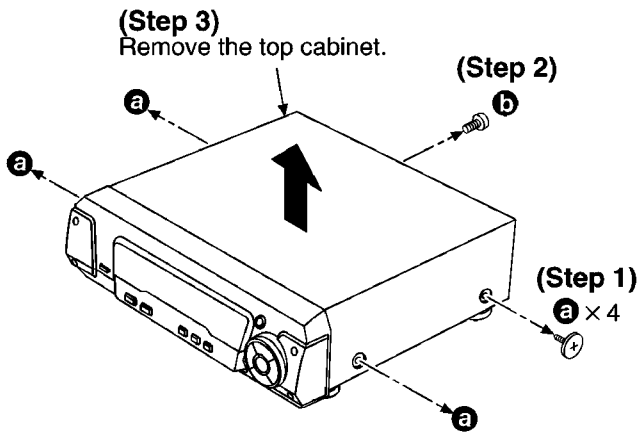

- (Step 5)**
Release the 5 claws, and then remove the FL P.C.B..

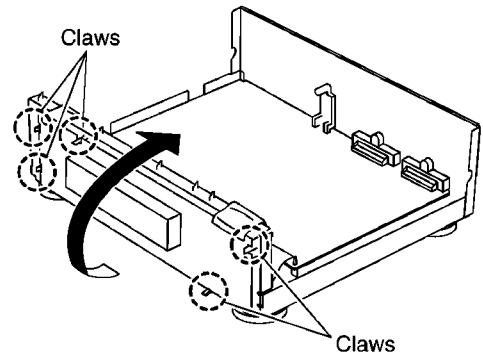

- Check the FL P.C.B. as shown below.

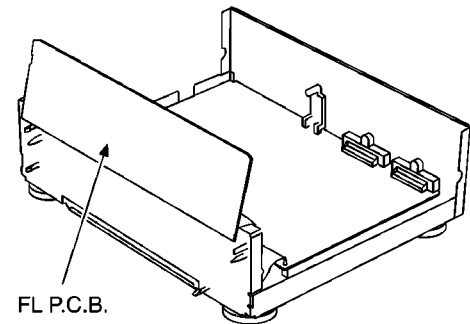

3.2. Checking for the main P.C.B.

- Follow the (Step 1) - (Step 3) of item 3.1.

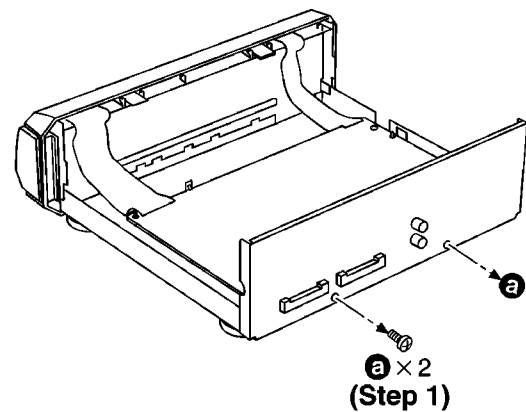

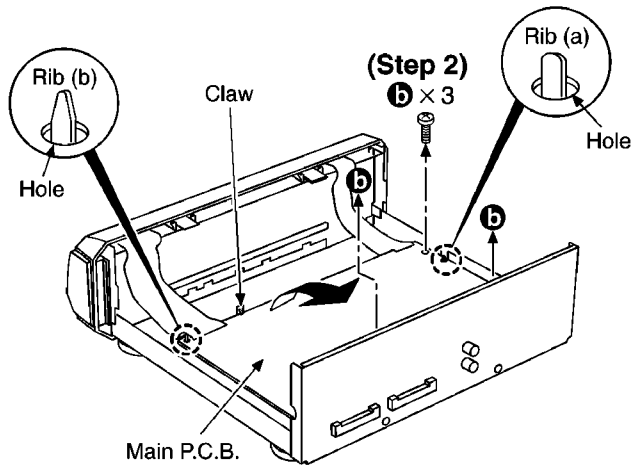
**(Step 3)**

Release the claw, and then lift up the main P.C.B..
 (Lift up the main P.C.B. until the rib (a) and rib (b) are released from the hole of main P.C.B..)

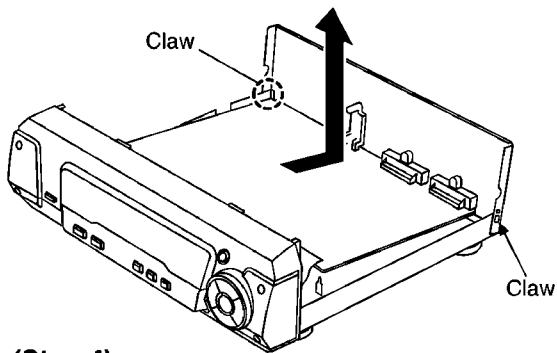
**(Step 4)**

Release the 2 claws, and then remove the main P.C.B. in the direction of arrow.

• Check the main P.C.B. as shown below.

(Step 5)

Insert the insulator sheet (paper etc).

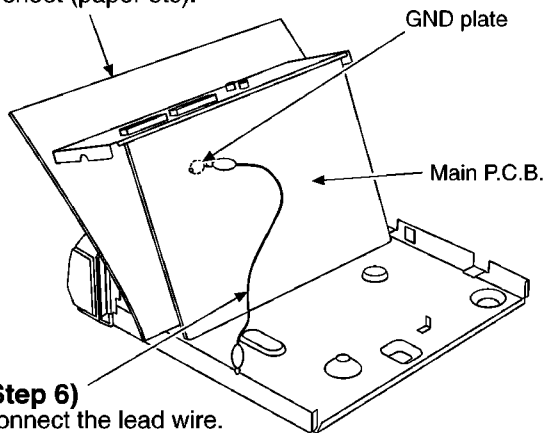
**(Step 6)**

Connect the lead wire.

4 To Supply Power Source

This unit is designed to operate on power supplied from system connected.

When a component requires service, use the system connections to supply power source.

For system connections, refer to

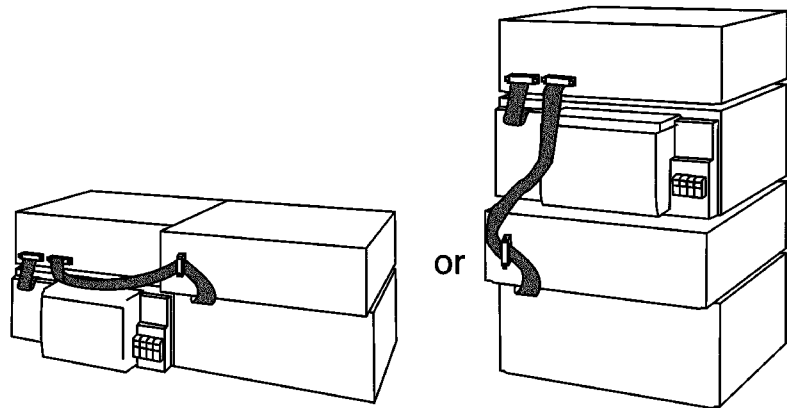

Fig. 4-1.

5 Schematic Diagram Notes

- This schematic diagram may be modified at any time with the development of new technology.

Notes:

S601:	Display mode switch (DISPLAY MODE)
S602:	Super sound EQ switch (SUPER SOUND EQ)
S603:	AI EQ switch (AI EQ)
S605:	Manual EQ switch (M1)
S606:	Manual EQ switch (M2)
S607:	Manual EQ switch (M3)
S608:	Multi control switch (►)
S609:	Multi control switch (▲)
S610:	Multi control switch (◀)
S611:	Multi control switch (▼)
S612:	Flat switch (FLAT)
S615:	EQ switch (EQ)

- Indicated voltage values are the standard values for the unit measured by the DC electronic circuit tester (high-impedance) with the chassis taken as standard. Therefore, there may exist some errors in the voltage values, depending on the internal impedance of the DC circuit tester.

No mark : Power on

- Important safety notice:

Components identified by \triangle mark have special characteristics important for safety.

Furthermore, special parts which have purposes of fire-retardant (resistors), high-quality sound (capacitors), low-noise (resistors), etc. are used.

When replacing any of components, be sure to use only manufacturer's specified parts shown in the parts list.

- The supply part number is described alone in the replacement parts list.
- Voltage and signal line

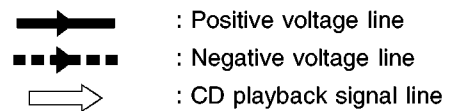

Caution!

IC and LSI are sensitive to static electricity.

Secondary trouble can be prevented by taking care during repair.

Cover the parts boxes made of plastics with aluminum foil.
Ground the soldering iron.

Put a conductive mat on the work table.

Do not touch the legs of IC or LSI with the fingers directly.

6 Schematic Diagram

SCHEMATIC DIAGRAM-1

NOTE:
 The number which noted at the connectors on the schematic diagram as "SCHEMATIC DIAGRAM-1" or "SCHEMATIC DIAGRAM-2" indicates the schematic diagram serial number located on the left corner in the schematic diagram.

A FL CIRCUIT

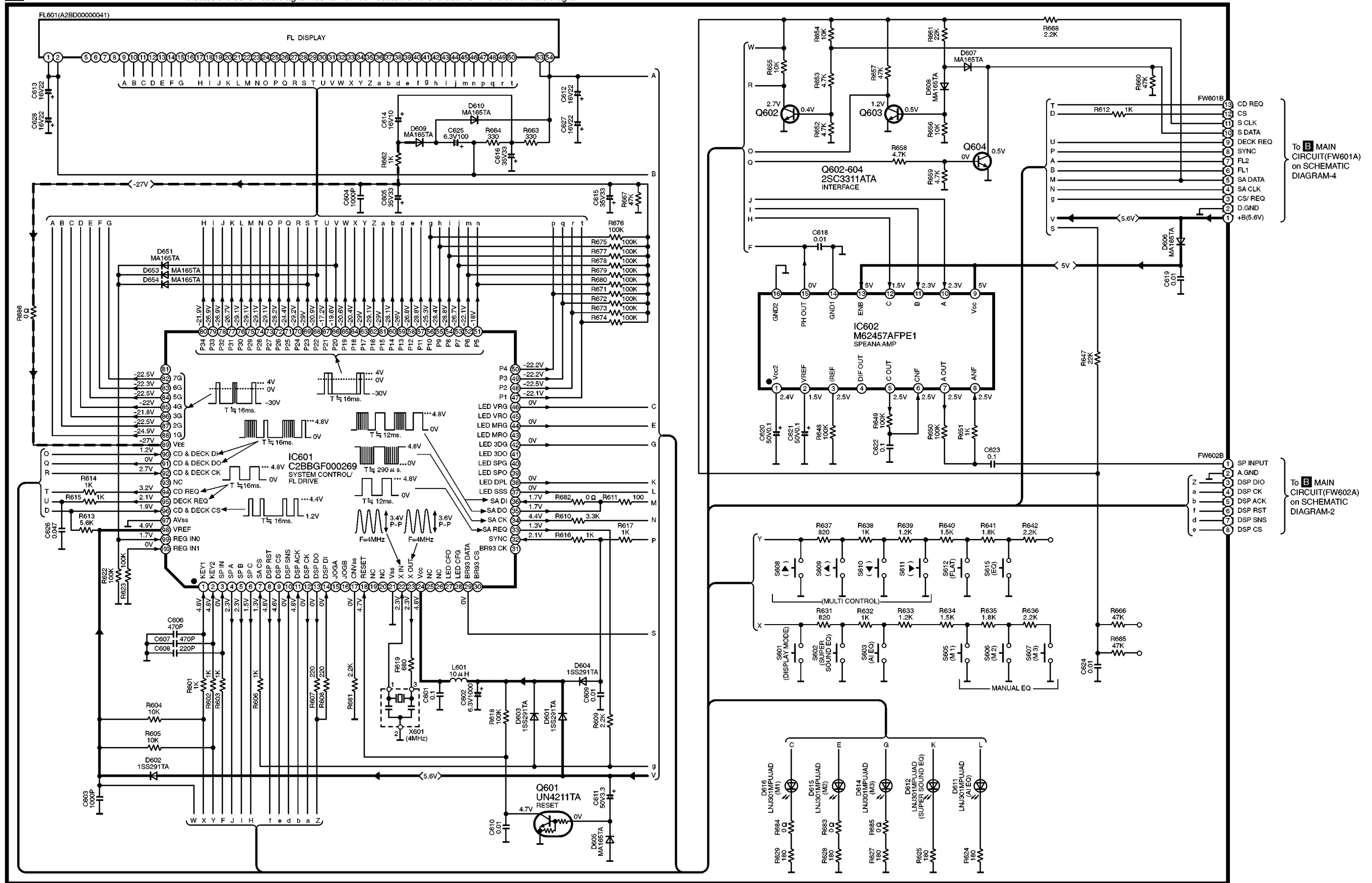

SH-EH580(EG) FL CIRCUIT DIAGRAM

SCHEMATIC DIAGRAM-2
B MAIN CIRCUIT

→ : POSITIVE VOLTAGE LINE
→ - : NEGATIVE VOLTAGE LINE
⇨ : CD PLAYBACK SIGNAL LINE

To A FL CIRCUIT(FW602B)
on SCHEMATIC DIAGRAM-1

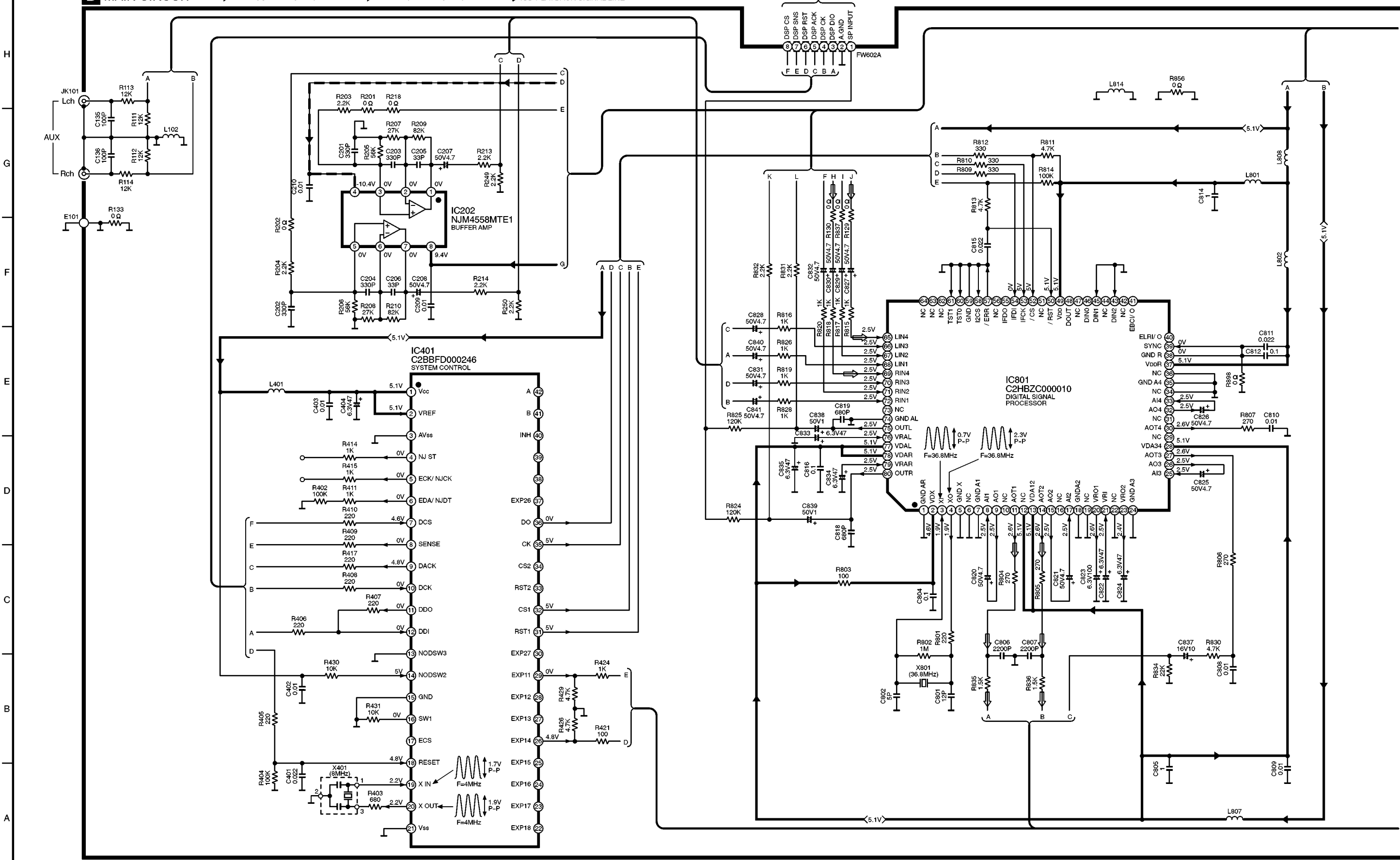

SH-EH580(EG) MAIN CIRCUIT DIAGRAM

SCHEMATIC DIAGRAM-3

B MAIN CIRCUIT → : POSITIVE VOLTAGE LINE → : NEGATIVE VOLTAGE LINE ⇨ : CD PLAYBACK SIGNAL LINE

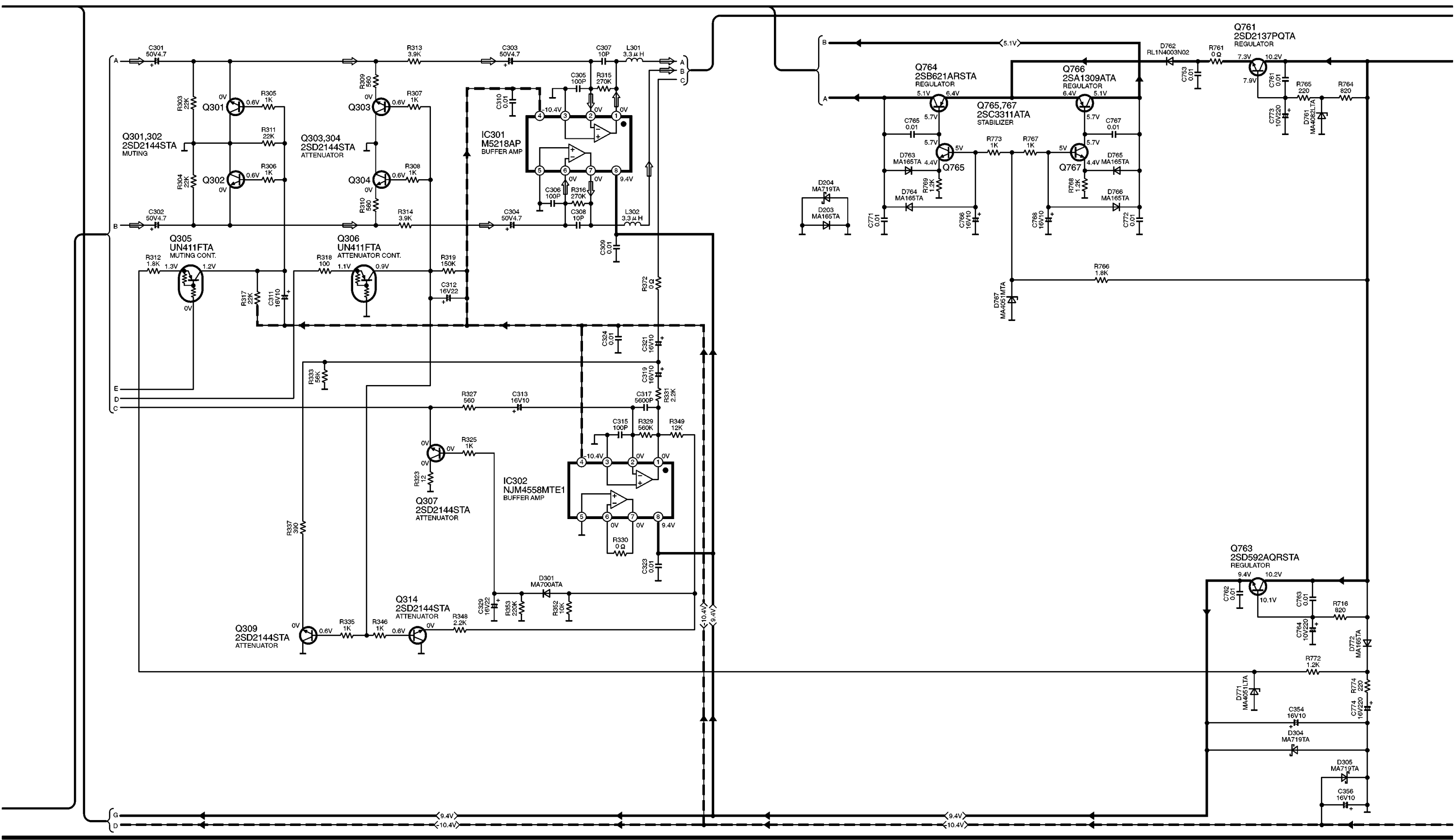

SH-EH580(EG) MAIN CIRCUIT DIAGRAM

SCHEMATIC DIAGRAM-4
B MAIN CIRCUIT

→ : POSITIVE VOLTAGE LINE ⇨ : CD PLAYBACK SIGNAL LINE
- - - : NEGATIVE VOLTAGE LINE

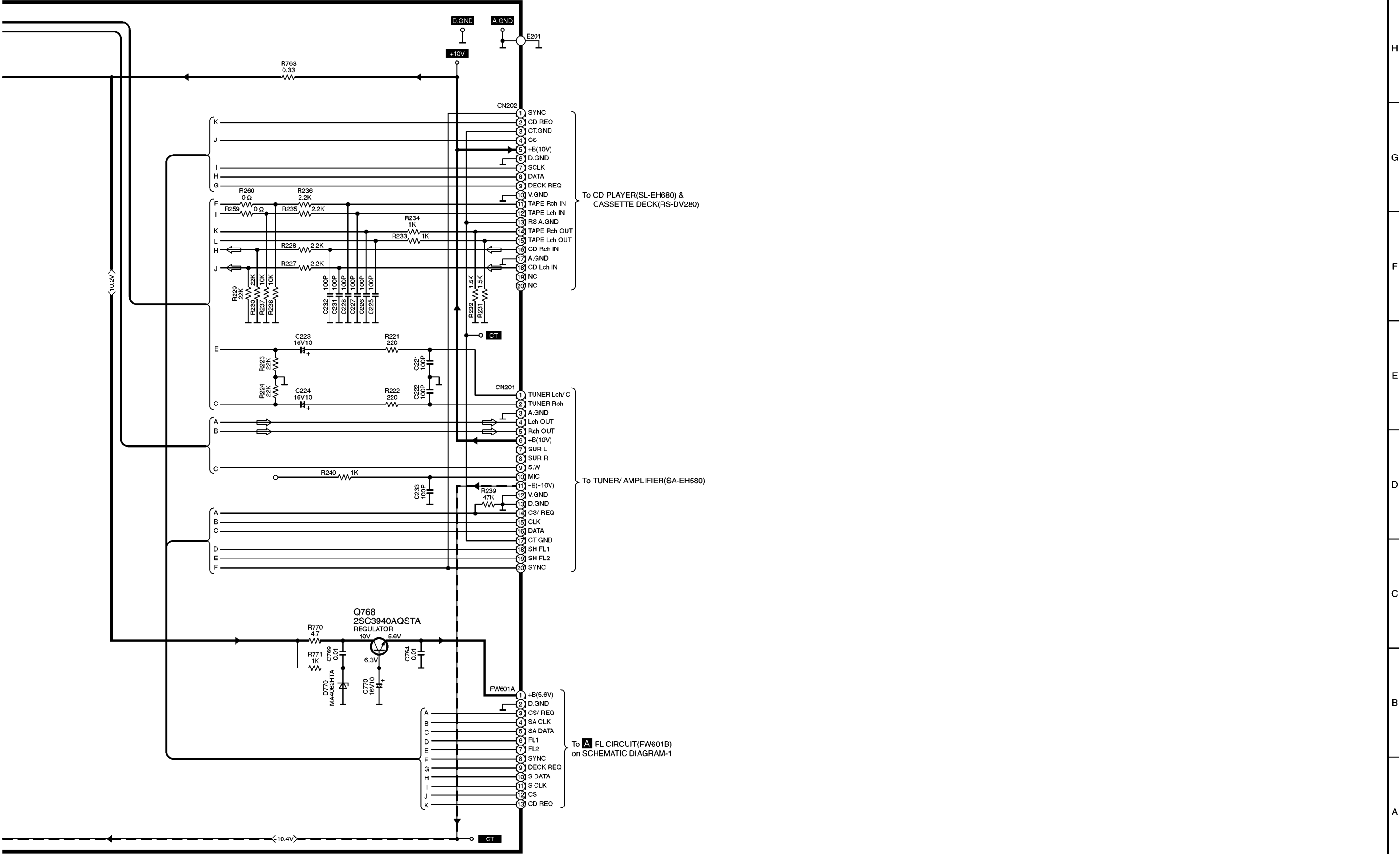

SH-EH580(EG) MAIN CIRCUIT DIAGRAM

H
G
F
E
D
C
B
A

25 26 27 28 29 30 31 32 33 34 35 36

7 Printed Circuit Board Diagram

Note: This printed circuit board diagram may be modified at any time with the development of new technology.

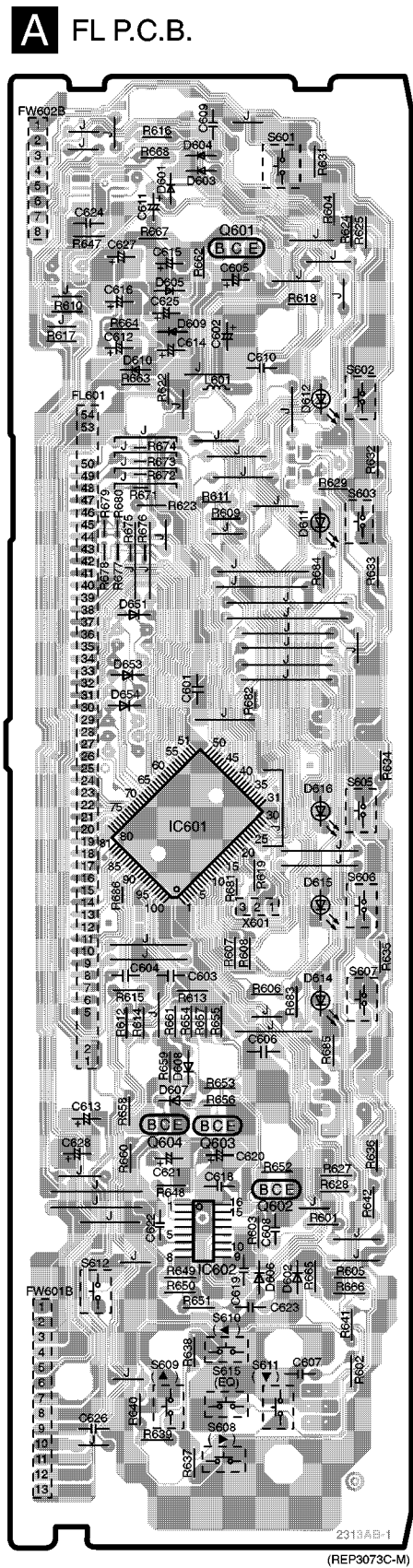

- DISPLAY MODE
- SUPER SOUND EQ
- AI EQ
- M1
- M2 MANUAL EQ
- M3

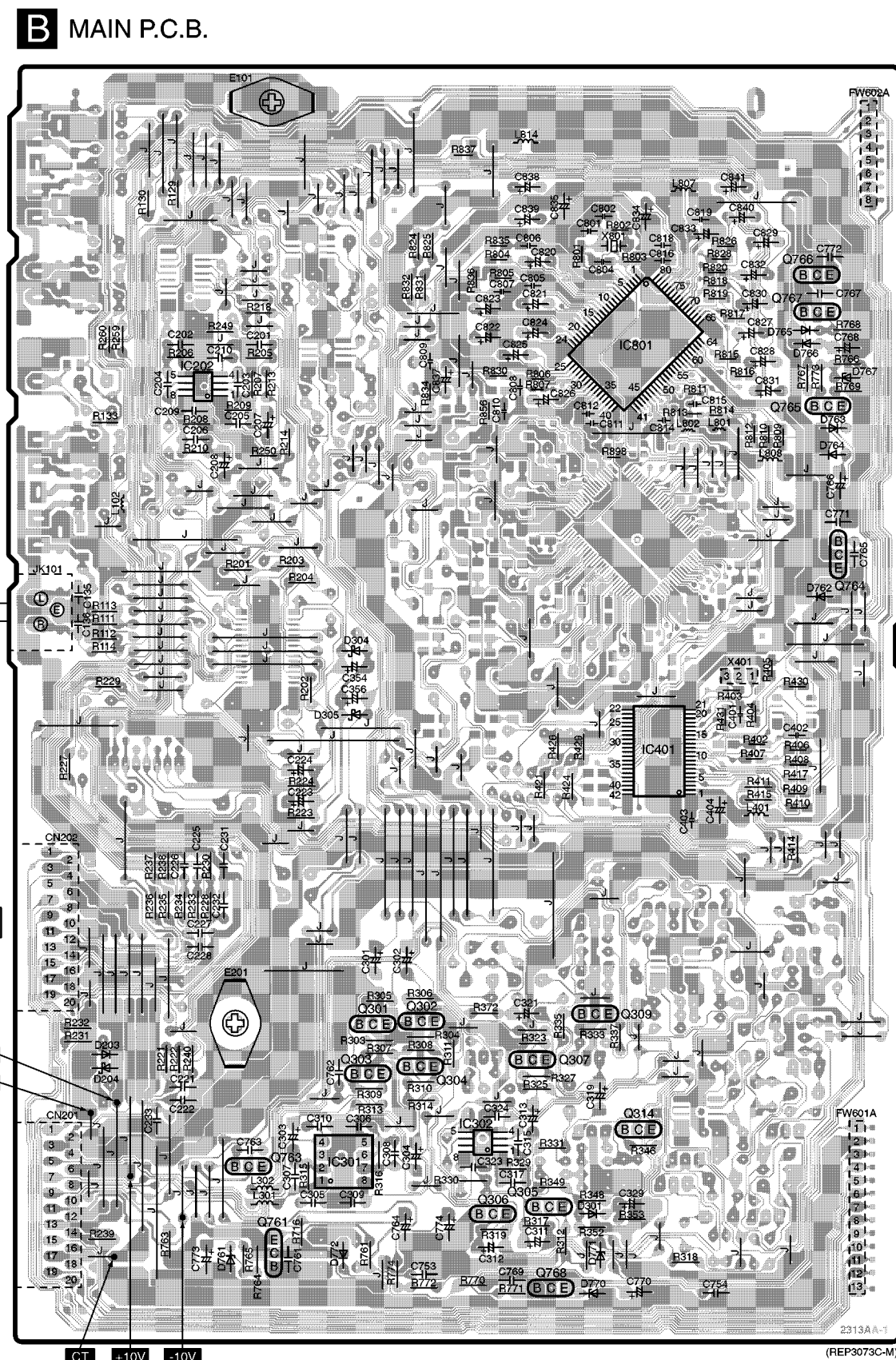

- AUX(DVD)
- To CD PLAYER & CASSETTE DECK
- D.GND
- A.GND
- To TUNER/AMPLIFIER

8 Type Illustration of ICs, Transistors and Diodes

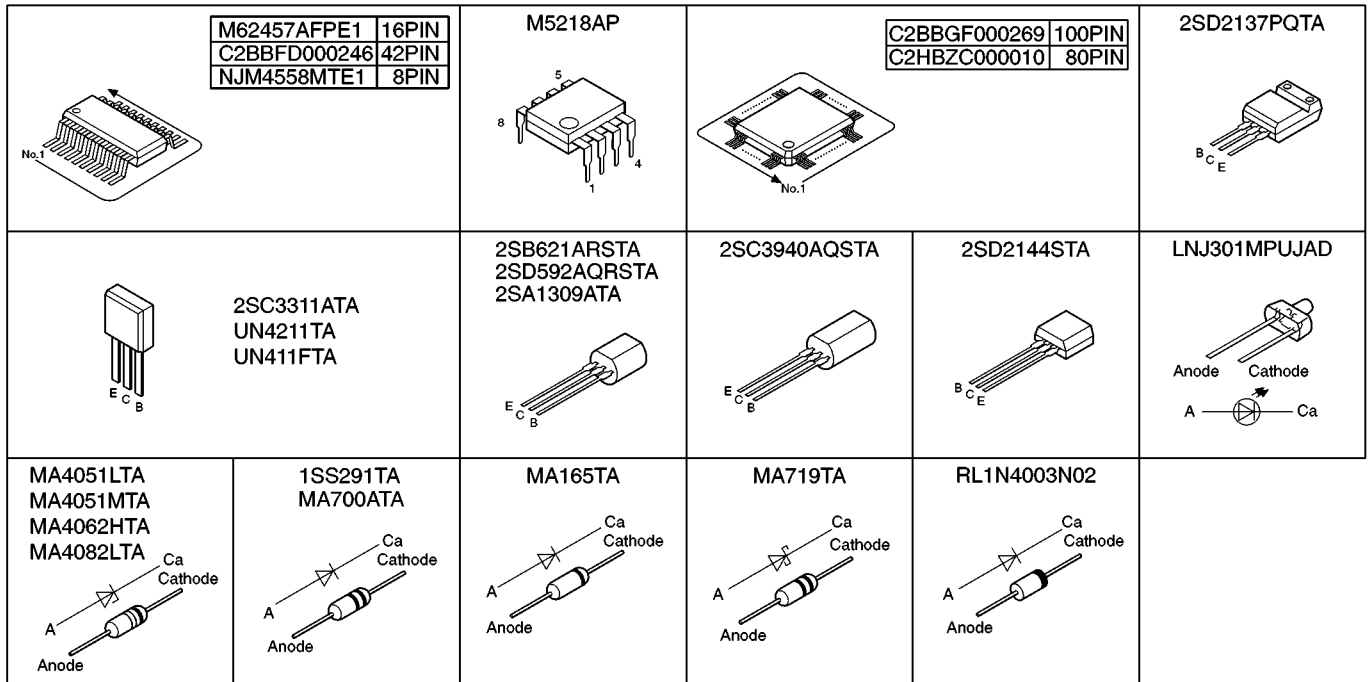

9 Wiring Connection Diagram

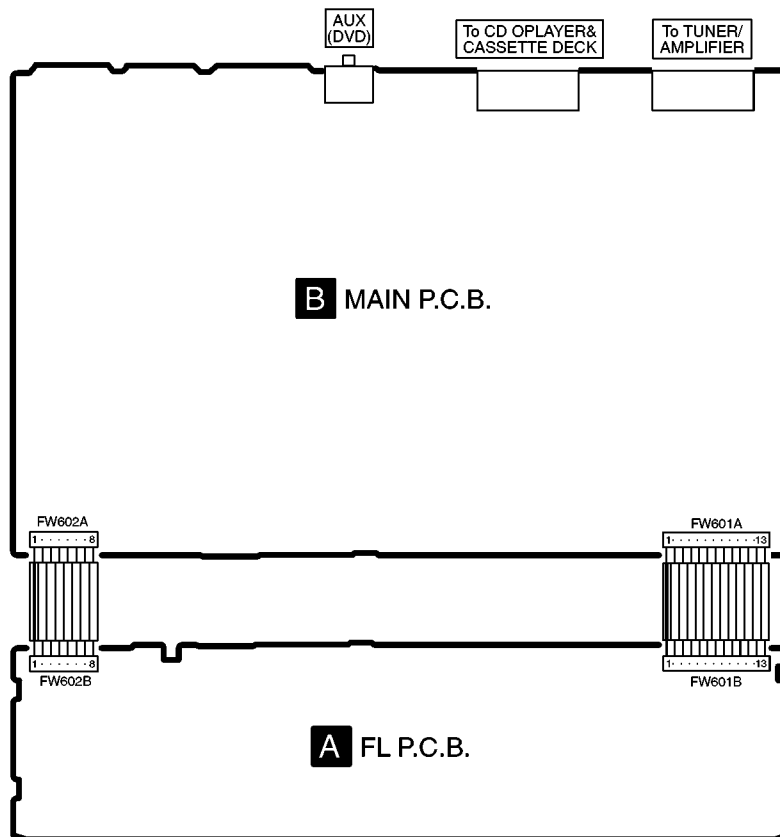

10 Block Diagram

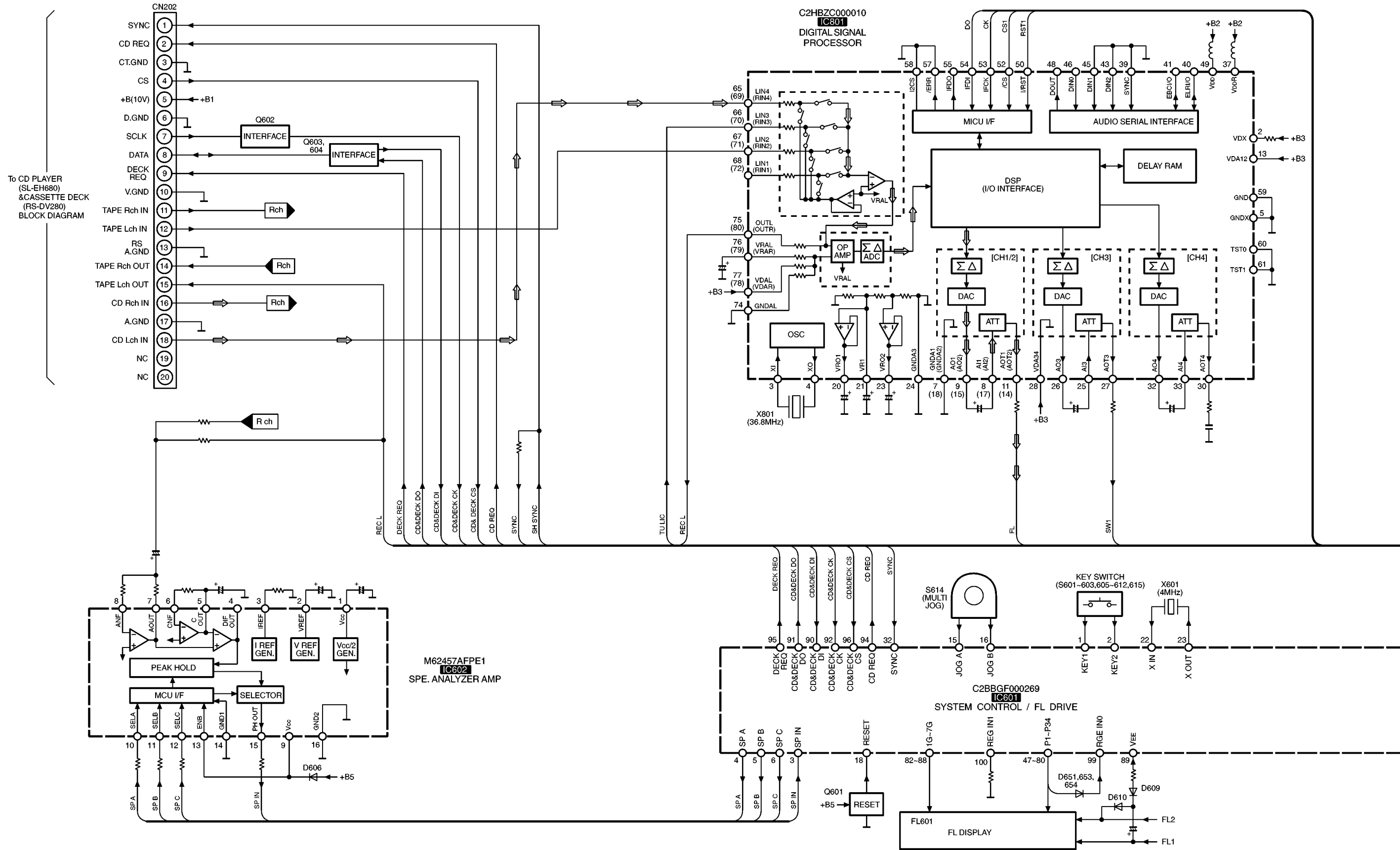

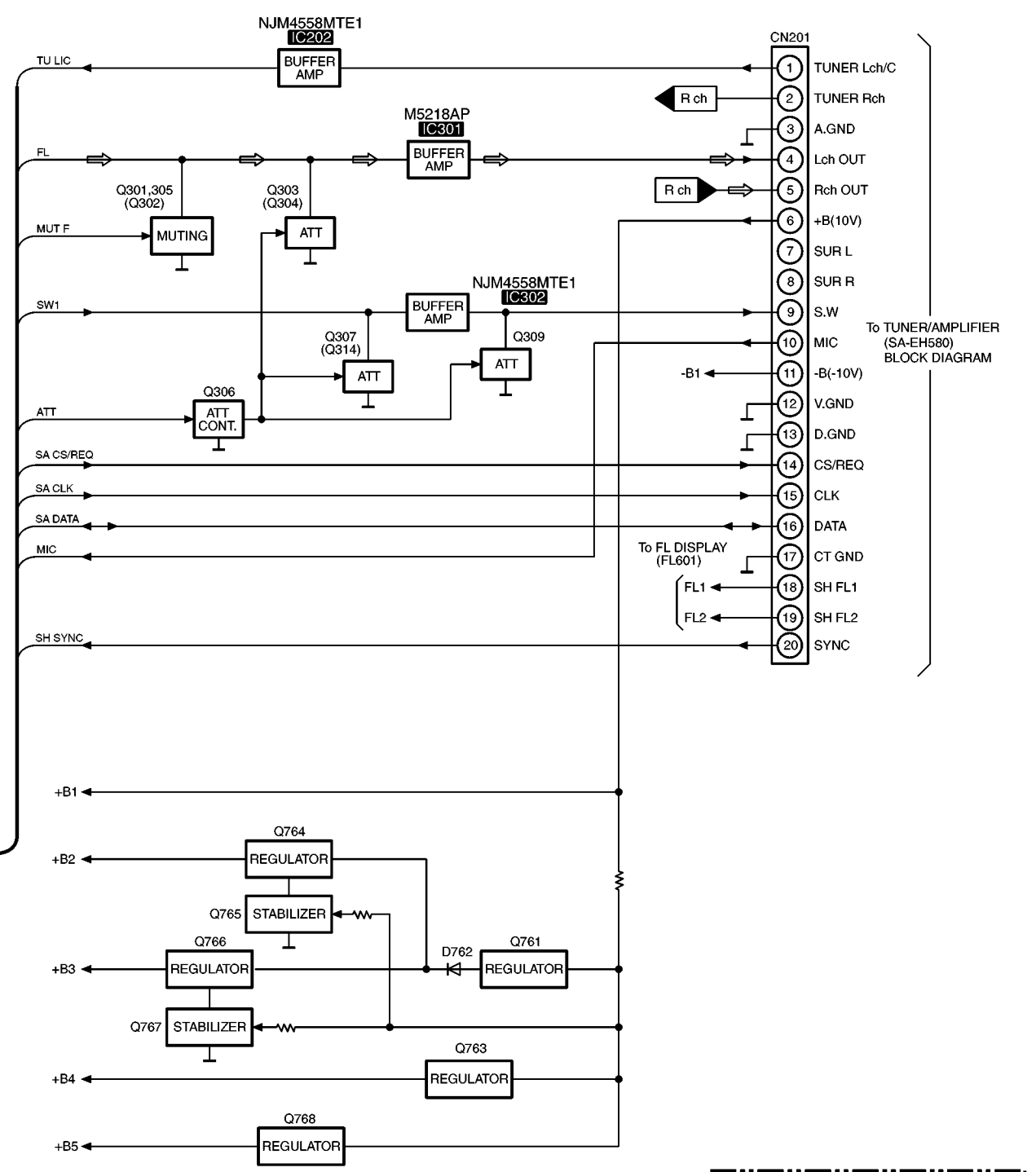
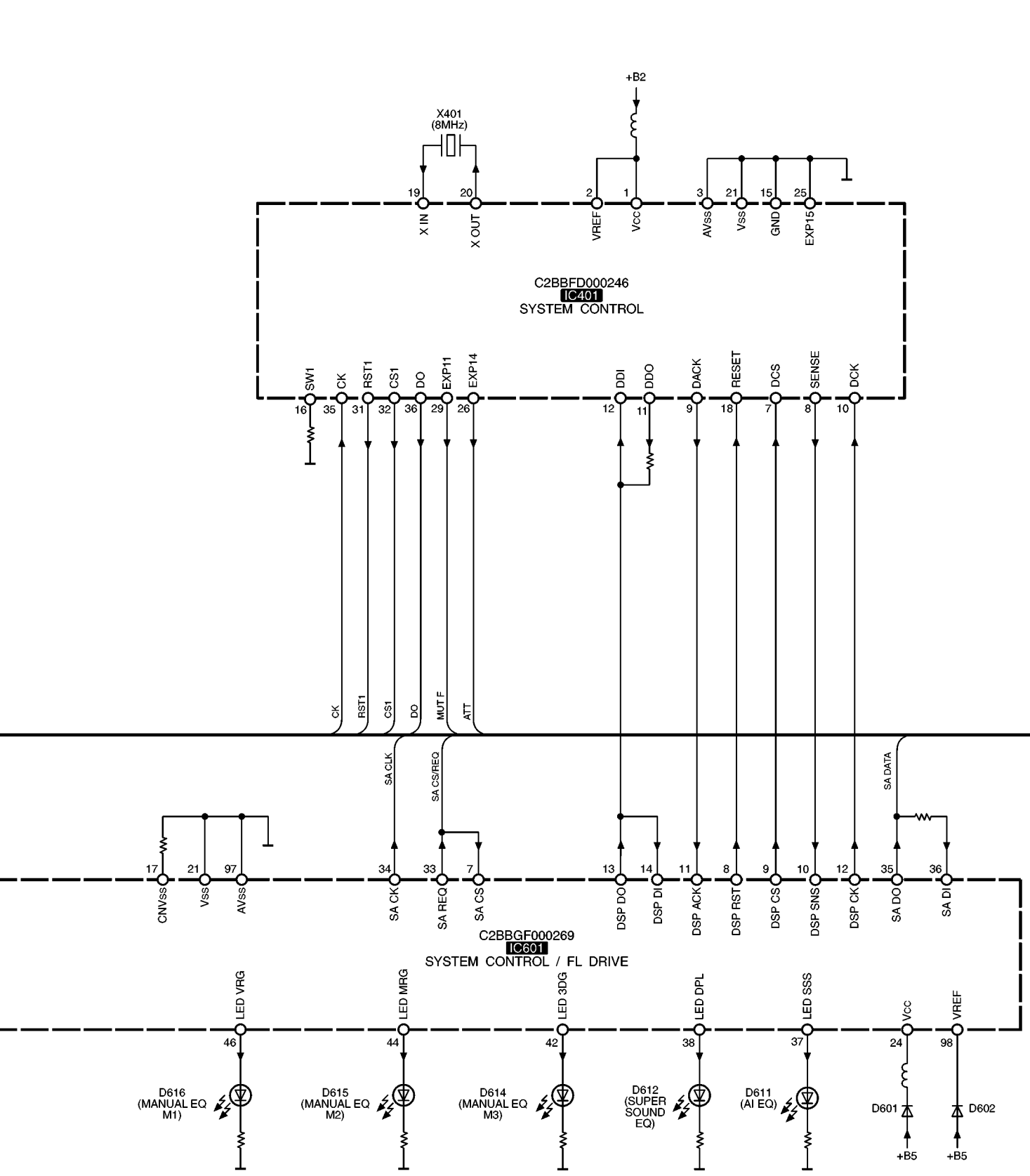

NOTES
 • —•—: CD PLAYBACK SIGNAL LINE
 • () indicates pin No. Right channel.

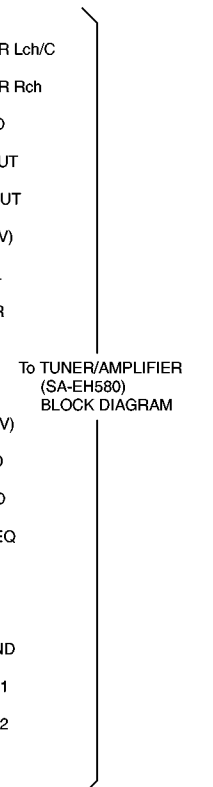

11 Terminal Function of ICs

11.1. IC601 (C2BBGF000269): System Control/FL Drive

Pin No.	Terminal Name	I/O	Function
1	KEY1	I	Operation key signal input
2	KEY2	I	Operation key signal input
3	SP IN	I	A/D signal input from IC602
4	SP A	O	Band select signal output for IC602
5	SP B	O	Band select signal output for IC602
6	SP C	O	Band select signal output for IC602
7	SA CS	I	Chip select signal input
8	DSP RST	O	Reset signal output for IC401
9	DSP CS	O	Chip select signal output for IC401
10	DSP SNS	I	Sense signal input from IC401
11	DSP ACK	I	Acknowledge signal input from IC401
12	DSP CK	O	Clock signal output for IC401
13	DSP DO	O	Data signal output for IC401
14	DSP DI	I	Data signal input from IC401
15	JOG A	-	Not used, open
16	JOG B	-	Not used, open
17	CNV _{SS}	-	GND terminal
18	RESET	I	System reset signal input
19	NC	-	Not used, open
20	NC	-	Not used, open
21	V _{SS}	-	GND terminal
22	X IN	I	Oscillator connected terminal (F=4 MHz)
23	X OUT	O	
24	V _{CC}	I	Power supply terminal
25	NC	-	Not used, open
26	NC	-	Not used, open
27	LED CFO	-	Not used, open
28	LED CFG	-	Not used, open
29	BR93 DATA	-	Not used, connected to GND
30	BR93 CS	-	Not used, open
31	BR93 CK	-	Not used, open
32	SYNC	I	Power failure detect signal input
33	SA REQ	O	Request signal output for Tuner/Amplifier
34	SA CK	O	Serial communication signal to Tuner/Amplifier (Clock signal output)
35	SA DO	O	Serial communication signal to Tuner/Amplifier (Data signal output)
36	SA DI	I	Serial communication signal to Tuner/Amplifier (Data signal input)
37	LED SSS	O	LED (AI EQ) signal output
38	LED DPL	O	LED (SUPER SOUND EQ) signal output
39	LED SPO	-	Not used, open
40	LED SPG	-	Not used, open
41	LED 3DO	-	Not used, open
42	LED 3DG	O	LED (M3) signal output
43	LED MRO	-	Not used, open
44	LED MRG	O	LED (M2) signal output
45	LED VRO	-	Not used, open
46	LED VRG	O	LED (M1) signal output
47 80	P1 P34	O	FL segment signal output
81	NC	-	Not used, open
82 88	7G 1G	O	FL grid signal output
89	V _{EE}	I	Power supply terminal (Negative)
90	CD&DECK DI	I	Data signal input (CD and Deck mechanism)
91	CD&DECK DO	O	Data signal output (CD and Deck mechanism)

Pin No.	Terminal Name	I/O	Function
92	CD&DECK CK	I	Clock signal input (CD and Deck mechanism)
93	NC	-	Not used, open
94	CD REQ	O	Serial data request signal output for CD
95	DECK REQ	O	Serial data request signal output for Deck mechanism
96	CD&DECK CS	I	Chip select signal input (CD and Deck mechanism)
97	AV _{SS}	-	GND terminal
98	VREF	I	Reference voltage input
99	REGIN0	I	Destination select signal input
100	REGIN1	I	Destination select signal input

12 Replacement Parts List

Notes:

- Important safety notice:

Components identified by Δ mark have special characteristics important for safety.

Furthermore, special parts which have purposes of fire-retardant (resistors), high-quality sound (capacitors), low-noise (resistors), etc. are used.

When replacing any of components, be sure to use only manufactures specified parts shown in the parts list.

- The marking [RTL] indicates that retention time is limited for this item. After the discontinuation of this assembly in production, it will no longer be available.
- All parts are supplied by MESA.

Ref. No.	Part No.	Part Name & Description	Pcs	Remarks
1	RKM0400-1S	CABINET	1	
2	RHD30007-1S	SCREW	4	
3	XTB3+8JFZ	SCREW	9	
4	RKA0105-K	RUBBER	4	
5	RKA0106-N	FOOT RING	4	
6	RYP1099-N	FRONT PANEL UNIT	1	
6-1	RGB0025-A	TECHNICS BADGE	1	
6-2	RKW0576A-1V	FL WINDOW	1	
C135,36	ECUV1H101KCV	50V 100P	2	F1H1H101A720
C201-04	ECBT1H331KB5	50V 330P	4	F1D1H331A012
C205,06	ECBT1H330J5	50V 33P	2	F1D1H330A006
C207,08	RCE1HKA4R7BG	50V 4.7U	2	F2A1H4R70009
C209,10	ECBT1C103MS5	16V 0.01U	2	F1D1C103A004
C221,22	ECBA1H101KB5	50V 100P	2	
C223,24	ECA1CAK100XB	16V 10U	2	
C225-28	ECBA1H101KB5	50V 100P	4	
C231-33	ECBA1H101KB5	50V 100P	3	
C301-04	RCE1HKA4R7BG	50V 4.7U	4	F2A1H4R70009
C305,06	ECBA1H101KB5	50V 100P	2	
C307,08	ECBT1H100JCS	50V 10P	2	F1D1H100A015
C309,10	ECBT1C103MS5	16V 0.01U	2	F1D1C103A004
C311	ECA1CAK100XB	16V 10U	1	
C312	ECA1CAK220XB	16V 22U	1	
C313	ECA1CAK100XB	16V 10U	1	
C315	ECBA1H101KB5	50V 100P	1	
C317	ECBT1C562KR5	16V 5600P	1	F1D1C562A010
C319	ECA1CAK100XB	16V 10U	1	
C321	ECA1CAK100XB	16V 10U	1	
C323,24	ECBT1C103MS5	16V 0.01U	2	F1D1C103A004
C329	ECA1CAK220XB	16V 22U	1	
C354	ECA1CAK100XB	16V 10U	1	
C356	ECA1CAK100XB	16V 10U	1	
C401	ECUVNE223KBV	25V 0.22U	1	F1H1E223A050
C402,03	ECUVNH103KBV	50V 0.01U	2	F1H1H103A748
C404	ECA0JAK470XH	6.3V 47U	1	ECA0JAK470XB
C601	ECBT1H104KB5	50V 0.1U	1	F1D1H1040002
C602	ECA0JM102	6.3V 1000U	1	ECEA0JU102B
C603,04	ECBA1H102KB5	50V 1000P	2	
C605	ECA1VAK330XB	35V 33U	1	
C606,07	ECBT1H471KB5	50V 470P	2	F1D1H471A012
C608	ECBT1H221KB5	50V 220P	1	F1D1H221A012
C609,10	ECBT1C103MS5	16V 0.01U	2	F1D1C103A004
C611	ECA1HAK3R3XB	50V 3.3U	1	
C612,13	F2A1C220A034	16V 22U	2	
C614	ECA1CAK100XB	16V 10U	1	
C615	ECA1VAK330XB	35V 33U	1	
C616	ECEA1VRS330Q	35V 33U	1	
C618,19	ECBT1C103MS5	16V 0.01U	2	F1D1C103A004
C620,21	ECA1HAK0R1XB	50V 0.1U	2	
C622,23	ECBT1H104KB5	50V 0.1U	2	F1D1H1040002
C624	ECBT1C103MS5	16V 0.01U	1	F1D1C103A004

Ref. No.	Part No.	Part Name & Description	Pcs	Remarks
C625	ECA0JAK101XB	6.3V 100U	1	
C626	ECBT1H473KB5	50V 0.047U	1	F1D1H473A012
C627,28	F2A1C220A034	16V 22U	2	
C753,54	ECBT1C103MS5	16V 0.01U	2	F1D1C103A004
C761-63	ECBT1C103MS5	16V 0.01U	3	F1D1C103A004
C764	ECA1AAK221XH	10V 220U	1	
C765	ECBT1C103MS5	16V 0.01U	1	F1D1C103A004
C766	ECA1CAK100XB	16V 10U	1	
C767	ECBT1C103MS5	16V 0.01U	1	F1D1C103A004
C768	ECA1CAK100XB	16V 10U	1	
C769	ECBT1C103MS5	16V 0.01U	1	F1D1C103A004
C770	ECA1CAK100XB	16V 10U	1	
C771,72	ECBT1C103MS5	16V 0.01U	2	F1D1C103A004
C773	ECA1AAK221XH	10V 220U	1	
C774	ECA1CAM221XB	16V 220U	1	
C801	ECUV1H120JCV	50V 12P	1	ECJ1VC1H120J
C802	ECUV1H050CCV	50V 5P	1	
C804	ECUVNC104KBV	16V 0.1U	1	ECJ1VB1C104K
C805	ECUVNJ105KBV	6.3V 1U	1	F1H0J105A002
C806,07	ECUV1H222KBV	50V 2200P	2	ECJ1VB1H222K
C808-10	ECUVNH103KBV	50V 0.01U	3	F1H1H103A748
C811	ECUVNE223KBV	25V 0.22U	1	F1H1E223A050
C812	ECUVNC104KBV	16V 0.1U	1	ECJ1VB1C104K
C814	ECUVNJ105KBV	6.3V 1U	1	F1H0J105A002
C815	ECUVNE223KBV	25V 0.22U	1	F1H1E223A050
C816	ECUVNC104KBV	16V 0.1U	1	ECJ1VB1C104K
C818,19	ECJ1VB1H681K	35V 680P	2	
C820,21	RCE1HKA4R7BG	50V 4.7U	2	F2A1H4R70009
C822	ECA0JAK470XH	6.3V 47U	1	ECA0JAK470XB
C823	EEAPC0J101B	6.3V 100U	1	
C824	ECA0JAK470XH	6.3V 47U	1	ECA0JAK470XB
C825-32	RCE1HKA4R7BG	50V 4.7U	8	F2A1H4R70009
C833-35	ECA0JAK470XH	6.3V 47U	3	ECA0JAK470XB
C837	ECA1CAK100XB	16V 10U	1	
C838,39	ECA1HAK010XI	50V 10U	2	ECA1HAK010XB
C840,41	RCE1HKA4R7BG	50V 4.7U	2	F2A1H4R70009
CN201	RJT065A20	CONNECTOR (20P)	1	K1FA220B0007
CN202	RJT065K20	CONNECTOR (20P)	1	K1FA220B0006
D203	MA165	DIODE	1	MA2C165
D204	MA719TA	DIODE	1	MA2C71900A
D301	MA700	DIODE	1	MA2C700
D304,05	MA719TA	DIODE	2	MA2C71900A
D601-04	1SS291TA	DIODE	4	
D605-10	MA165	DIODE	6	MA2C165
D611,12	LNJ301MPUJAD	LED	2	
D614-16	LNJ301MPUJAD	LED	3	
D651	MA165	DIODE	1	MA2C165
D653,54	MA165	DIODE	2	MA2C165
D761	MA4082LTA	DIODE	1	MAZ40820LF
D762	RL1N4003N02	DIODE	1	B0AAMM000009
D763-66	MA165	DIODE	4	MA2C165
D767	MA4051M	DIODE	1	MAZ40510M
D770	MA4062H	DIODE	1	MAZ40620H
D771	MA4051-L	DIODE	1	MAZ40510L
D772	MA165	DIODE	1	MA2C165
FL601	A2BD00000041	FL DISPLAY	1	
IC202	NJM4558MTE1	IC	1	C0ABBB000109
IC301	M5218AP	IC	1	C0AABB000055
IC302	NJM4558MTE1	IC	1	C0ABBB000109
IC401	C2BBFD000246	IC	1	
IC601	C2BBGF000269	IC	1	
IC602	M62457APPE1	IC	1	C1BB00000486
IC801	C2HBZC000010	IC	1	
JK101	SJF3068-7N	JK, AUX (DVD)	1	K2HA102B0046

Ref. No.	Part No.	Part Name & Description	Pcs	Remarks
L102	RLBV102V-Y	COIL	1	J0JBC0000014
L301,02	RLQA3R3JT1-Y	COIL	2	G0C3R3JA0019
L401	RLQB100JTD-D	COIL	1	G0C100JA0030
L601	RLQA100JT1-Y	COIL	1	G0C100JA0019
L801	RLBV60LAV-Y	COIL	1	J0JCC0000077
L802	RLBV102V-Y	COIL	1	J0JBC0000014
L807	G0A200D00002	COIL	1	△
L808	RLQB100JTD-D	COIL	1	G0C100JA0030
L814	G0A200D00002	COIL	1	△
PCB1	REP3073C-M	PCB ASS'Y	1	[RTL]
Q301-04	2SD2144S	TRANSISTOR	4	B1AAGC000006
Q305,06	UN411FTA	TRANSISTOR	2	UNR411F00A
Q307	2SD2144S	TRANSISTOR	1	B1AAGC000006
Q309	2SD2144S	TRANSISTOR	1	B1AAGC000006
Q314	2SD2144S	TRANSISTOR	1	B1AAGC000006
Q601	UN4211	TRANSISTOR	1	UNR4211
Q602-04	2SC3311ATA	TRANSISTOR	3	2SC3311A0A
Q761	2SD2137PQTA	TRANSISTOR	1	2SD21370PA
Q763	2SD0592AWA	TRANSISTOR	1	
Q764	2SB0621AHA	TRANSISTOR	1	
Q765	2SC3311ATA	TRANSISTOR	1	2SC3311A0A
Q766	2SA1309ATA	TRANSISTOR	1	2SA1309AWA
Q767	2SC3311ATA	TRANSISTOR	1	2SC3311A0A
Q768	2SC3940AQSTA	TRANSISTOR	1	2SC3940ARA
R111-14	ERDS2FJ123	1/4W 12K	4	
R129,30	ERDS2T0T	1/4W 0	2	
R133	ERJ3GEY0R00V	1/16W 0	1	
R201,02	ERDS2T0T	1/4W 0	2	
R203,04	ERDS2FJ222	1/4W 2.2K	2	ERDS2TJ222T
R205,06	ERDS2FJ563	1/4W 56K	2	ERDS2TJ563T
R207,08	ERDS2FJ273	1/4W 27K	2	
R209,10	ERDS2TJ823T	1/4W 82K	2	
R213,14	ERDS2FJ222	1/4W 2.2K	2	ERDS2TJ222T
R218	ERDS2T0T	1/4W 0	1	
R221,22	ERDS2FJ221	1/4W 220	2	
R223,24	ERDS2FJ223	1/4W 22K	2	
R227,28	ERDS2FJ222	1/4W 2.2K	2	ERDS2TJ222T
R229,30	ERDS2FJ223	1/4W 22K	2	
R231,32	ERDS2FJ152	1/4W 1.5K	2	
R233,34	ERDS2FJ102	1/4W 1K	2	
R235,36	ERDS2FJ222	1/4W 2.2K	2	ERDS2TJ222T
R237,38	ERDS2FJ103	1/4W 10K	2	
R239	ERDS2FJ473	1/4W 47K	1	ERDS2TJ473T
R240	ERDS2FJ102	1/4W 1K	1	
R249,50	ERDS2FJ222	1/4W 2.2K	2	ERDS2TJ222T
R259,60	ERDS2T0T	1/4W 0	2	
R303,04	ERDS2FJ223	1/4W 22K	2	
R305-08	ERDS2FJ102	1/4W 1K	4	
R309,10	ERDS2FJ561	1/4W 560	2	
R311	ERDS2FJ223	1/4W 22K	1	
R312	ERDS2FJ182	1/4W 1.8K	1	
R313,14	ERDS2TJ392T	1/4W 3.9K	2	
R315,16	ERDS2FJ274	1/4W 270K	2	
R317	ERDS2FJ223	1/4W 22K	1	
R318	ERDS2FJ101	1/4W 100	1	
R319	ERDS2FJ154	1/4W 150K	1	
R323	ERDS2FJ120	1/4W 12	1	
R325	ERDS2FJ102	1/4W 1K	1	
R327	ERDS2FJ561	1/4W 560	1	
R329	ERDS2FJ564	1/4W 560K	1	ERDS2TJ564T
R330	ERDS2T0T	1/4W 0	1	
R331	ERDS2FJ222	1/4W 2.2K	1	ERDS2TJ222T
R333	ERDS2FJ563	1/4W 56K	1	ERDS2TJ563T
R335	ERDS2FJ102	1/4W 1K	1	
R337	ERDS2FJ391	1/4W 3.9K	1	ERDS2TJ391T
R346	ERDS2FJ102	1/4W 1K	1	
R348	ERDS2FJ222	1/4W 2.2K	1	ERDS2TJ222T
R349	ERDS2FJ123	1/4W 12K	1	
R352	ERDS2FJ103	1/4W 10K	1	
R353	ERDS2FJ224	1/4W 220K	1	

Ref. No.	Part No.	Part Name & Description	Pcs	Remarks
R372	ERDS2T0T	1/4W 0	1	
R402	ERJ3GEYJ104Z	1/16W 100K	1	
R403	ERJ3GEYJ681V	1/16W 680	1	D0GB681JA002
R404	ERJ3GEYJ104Z	1/16W 100K	1	
R405-10	ERJ3GEYJ221V	1/16W 220	6	
R411	ERDS2FJ102	1/4W 1K	1	
R414,15	ERDS2FJ102	1/4W 1K	2	
R417	ERJ3GEYJ221V	1/16W 220	1	
R421	ERDS2FJ101	1/4W 100	1	
R424	ERDS2FJ102	1/4W 1K	1	
R426	ERDS2FJ472	1/4W 4.7K	1	ERDS2TJ472T
R429	ERDS2FJ472	1/4W 4.7K	1	ERDS2TJ472T
R430,31	ERJ3GEYJ103Z	1/16W 10K	2	
R601-03	ERDS2FJ102	1/4W 1K	3	
R604,05	ERDS2FJ103	1/4W 10K	2	
R606	ERDS2FJ102	1/4W 1K	1	
R607,08	ERDS2FJ221	1/4W 220	2	
R609	ERDS2FJ222	1/4W 2.2K	1	ERDS2TJ222T
R610	ERDS2FJ332	1/4W 3.3K	1	
R611	ERDS2FJ101	1/4W 100	1	
R612	ERDS2FJ102	1/4W 1K	1	
R613	ERDS2FJ562	1/4W 5.6K	1	
R614-17	ERDS2FJ102	1/4W 1K	4	
R618	ERDS2FJ104	1/4W 100K	1	ERDS2TJ104T
R619	ERDS2FJ681	1/4W 680	1	ERDS2TJ681T
R622,23	ERDS2FJ104	1/4W 100K	2	ERDS2TJ104T
R624,25	ERDS2TJ181	1/4W 180	2	
R627-29	ERDS2TJ181	1/4W 180	3	
R631	ERDS2FJ821	1/4W 820	1	ERDS2TJ821T
R632	ERDS2FJ102	1/4W 1K	1	
R633	ERDS2FJ122	1/4W 1.2K	1	ERDS2TJ122T
R634	ERDS2FJ152	1/4W 1.5K	1	
R635	ERDS2FJ182	1/4W 1.8K	1	
R636	ERDS2FJ222	1/4W 2.2K	1	ERDS2TJ222T
R637	ERDS2FJ821	1/4W 820	1	ERDS2TJ821T
R638	ERDS2FJ102	1/4W 1K	1	
R639	ERDS2FJ122	1/4W 1.2K	1	ERDS2TJ122T
R640	ERDS2FJ152	1/4W 1.5K	1	
R641	ERDS2FJ182	1/4W 1.8K	1	
R642	ERDS2FJ222	1/4W 2.2K	1	ERDS2TJ222T
R647	ERDS2FJ223	1/4W 22K	1	
R648-50	ERDS2FJ104	1/4W 100K	3	ERDS2TJ104T
R651	ERDS2FJ102	1/4W 1K	1	
R652,53	ERDS2FJ472	1/4W 4.7K	2	ERDS2TJ472T
R654-56	ERDS2FJ103	1/4W 10K	3	
R657	ERDS2FJ473	1/4W 47K	1	ERDS2TJ473T
R658,59	ERDS2FJ472	1/4W 4.7K	2	ERDS2TJ472T
R660	ERDS2FJ473	1/4W 47K	1	ERDS2TJ473T
R661	ERDS2FJ223	1/4W 22K	1	
R662	ERDS2FJ102	1/4W 1K	1	
R663,64	ERDS2FJ331	1/4W 330	2	
R665-67	ERDS2FJ473	1/4W 47K	3	ERDS2TJ473T
R668	ERDS2FJ222	1/4W 2.2K	1	ERDS2TJ222T
R671-80	ERJ6GEYJ104V	1/8W 100K	10	
R681	ERJ3GEYJ222V	1/16W 2.2K	1	
R682	ERJ3GEY0R00V	1/16W 0	1	
R683-85	ERDS2T0T	1/4W 0	3	
R686	ERJ3GEY0R00V	1/16W 0	1	
R716	ERDS2FJ821	1/4W 820	1	ERDS2TJ821T
R761	ERDS2T0T	1/4W 0	1	
R763	ERQ16NKR33E	0.33	1	
R764	ERDS2FJ821	1/4W 820	1	ERDS2TJ821T
R765	ERDS2FJ221	1/4W 220	1	
R766	ERDS2FJ182	1/4W 1.8K	1	
R767	ERDS2FJ102	1/4W 1K	1	
R768,69	ERDS2FJ122	1/4W 1.2K	2	ERDS2TJ122T
R770	ERD2FCJ4R7	1/4W 4.7	1	ERD2FCVJ4R7T
R771	ERDS2FJ102	1/4W 1K	1	
R772	ERDS2FJ122	1/4W 1.2K	1	ERDS2TJ122T
R773	ERDS2FJ102	1/4W 1K	1	
R774	ERDS2FJ221	1/4W 220	1	
R801	ERJ3GEYJ221V	1/16W 220	1	
R802	ERJ3GEYJ105V	1/16W 1M	1	

Ref. No.	Part No.	Part Name & Description	Pcs	Remarks
R803	ERJ3GEYJ101V	1/16W 100	1	
R804-07	ERJ3GEYJ271V	1/16W 270	4	
R809,10	ERJ3GEYJ331V	1/16W 330	2	D0GB331JA002
R811	ERJ3GEYJ472V	1/16W 4.7K	1	
R812	ERJ3GEYJ331V	1/16W 330	1	D0GB331JA002
R813	ERJ3GEYJ472V	1/16W 4.7K	1	
R814	ERJ3GEYJ104Z	1/16W 100K	1	
R815-20	ERJ3GEYJ102V	1/16W 1K	6	ERJ3GEYJ102Z
R824,25	ERDS2TJ124	1/4W 120K	2	
R826	ERJ3GEYJ102V	1/16W 1K	1	ERJ3GEYJ102Z
R828	ERJ3GEYJ102V	1/16W 1K	1	ERJ3GEYJ102Z
R830	ERJ3GEYJ472V	1/16W 4.7K	1	
R831,32	ERDS2FJ222	1/4W 2.2K	2	ERDS2TJ222T
R834	ERJ3GEYJ223V	1/16W 22K	1	D0GB223JA002
R835,36	ERJ3GEYJ152V	1/16W 1.5K	2	
R837	ERJ3GEY0R00V	1/16W 0	1	
R856	ERJ3GEY0R00V	1/16W 0	1	
R898	ERJ3GEY0R00V	1/16W 0	1	
S601-03	EVQ11G05R	SW, OPERATRION	3	
S605-12	EVQ11G05R	SW, OPERATRION	8	
S615	EVQ11G05R	SW, EQ	1	
X401	RSXY8M00D01T	OSCILLATOR	1	H2B800400005
X601	H2B400400013	OSCILLATOR	1	
X801	RSXZ36M8M01T	OSCILLATOR	1	

13 Cabinet Parts Location

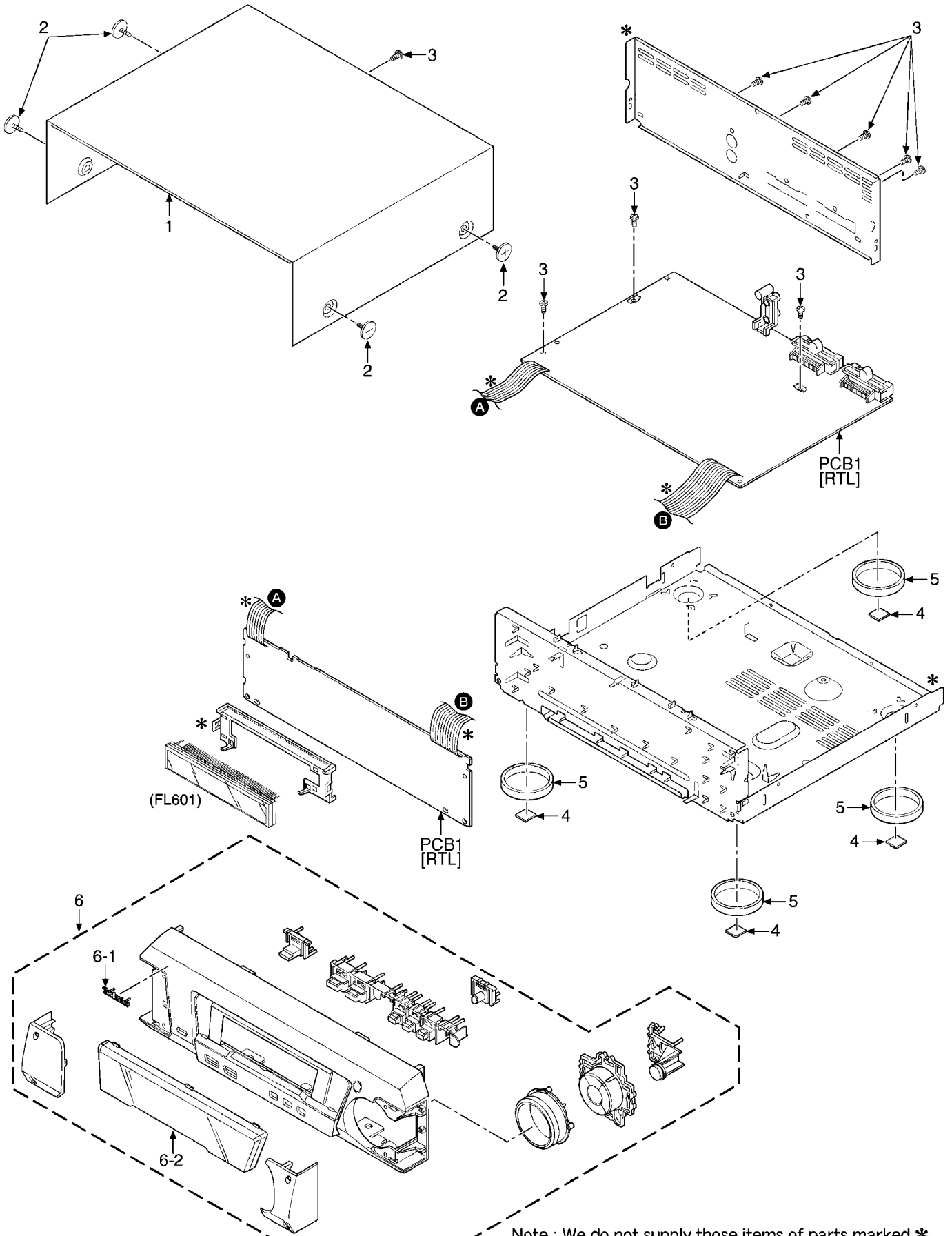

Note : We do not supply those items of parts marked *.
This "PCB1" is a combination PCB.