

Service Manual

Sound Processor

Sound Processor SH-EH750

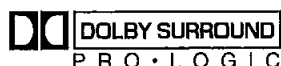

Colour

(S) Silver Type

Area

(E) Europe.

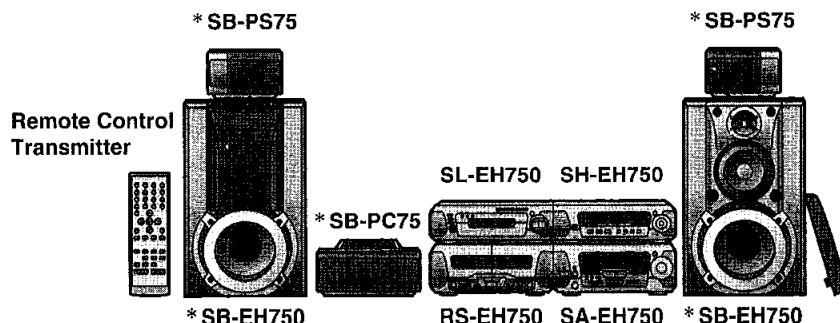

Because of unique interconnecting cables, when a component requires service, send or bring in the entire system.

System	SC-EH750
Sound Processor	SH-EH750
Tuner/Amplifier	SA-EH750
CD Changer	SL-EH750
Cassette Deck	RS-EH750
Front Speakers*	SB-EH750
Center Speaker*	SB-PC75
Surround Speakers*	SB-PS75

* : Made in Singapore.

Specifications

EQ/SFP Section

MANUAL GEQ:

Center frequency: 100 Hz, 315 Hz, 1 kHz, 3.15 kHz, 10 kHz
Level control: $\pm 3, 6, 9$ dB

EQ SPACE mode:

3 modes; HEAVY, CLEAR, HALL

3D Acoustic Image EQ:

3 modes; AI EQ, 3D AI1, 3D AI2

Pre-amplifier Section

Input sensitivity/impedance:

VCR (EXT); 250 mV/15 k Ω
AUX (DVD); 250 mV/15 k Ω
DVD 6CH INPUT (L/R/LS/RL/C/SubW); 250 mV/15 k Ω

Output level:

VCR REC OUT; 250 mV/1.5 k Ω
SUBWOOFER OUT; 2.5 V/2.2 k Ω

DOLBY PRO LOGIC Section

PRO LOGIC mode:

SURROUND

CENTER mode:

NORMAL

DELAY TIME:

20 ms (Fixed)

AV SURROUND Section

AV SURROUND mode:

SIMULATED STEREO
SUPER SURROUND (MUSIC, MOVIE)

DSP CONTROL Section

DSP CONTROL mode:

SEAT POSITION
CENTER FOCUS
VIRTUAL REAR SURROUND
MULTI REAR SURROUND

Spectrum Analyzer Section

Display mode:

NORMAL, PEAKHOLD, AURORA

General

Dimensions (W×H×D):

293×89×269 mm

Weight:

1.5 kg

Notes: Specifications are subject to change without notice.
Weight and dimensions are approximate.

Manufactured under license from Dolby Laboratories Licensing Corporation.
DOLBY, the double-D symbol and "PRO LOGIC" are trademarks of Dolby Laboratories Licensing Corporation.

⚠ WARNING

This service information is designed for experienced repair technicians only and is not designed for use by the general public. It does not contain warnings or cautions to advise non-technical individuals of potential dangers in attempting to service a product. Products powered by electricity should be serviced or repaired only by experienced professional technicians. Any attempt to service or repair the product or products dealt with in this service information by anyone else could result in serious injury or death.

Technics®

© 1999 Matsushita Electric Industrial Co., Ltd.
All rights reserved. Unauthorized copying and distribution is a violation of law.

■ Contents

	Page		Page
Location of Controls	2	Wiring Connection Diagram	18
Operation Checks and Component Replacement Procedures	3,4	Terminal Function of IC's	19
Schematic Diagram	5~14	Block Diagram	20~23
Printed Circuit Board Diagram	15~17	Replacement Parts List	24~26
Type Illustration of IC's, Transistors and Diodes	18	Cabinet Parts Location	27

NOTE:

Refer to the service manual for Model No. SA-EH750 (ORDER No. AD9903063C2) for information on "Accessories", "Connections", "Installation", "Operations" and "Packaging".

■ Location of Controls

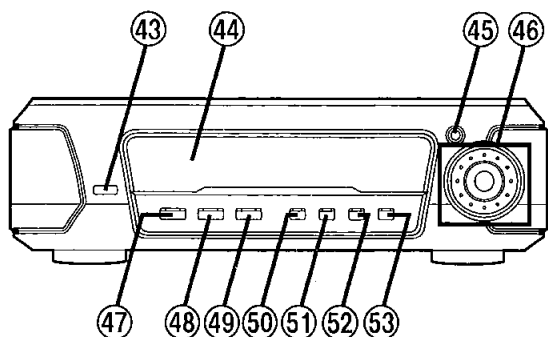

- ④③ Display mode select button (DISPLAY MODE)
- ④④ Display
- ④⑤ 3D AI EQ button (3D AI EQ)
- ④⑥ Jog control and joy stick (MULTI JOG)
- ④⑦ DOLBY PRO LOGIC on/off button
(□□ PRO LOGIC, OFF/ON)
- ④⑧ Super surround button and indicator
(SUPER SURROUND)
- ④⑨ Simulated stereo on/off button and indicator
(SIMULATED STEREO)
- ⑤⑦ Center focus button and indicator (CENTER FOCUS)
- ⑤① Virtual rear surround button and indicator
(VIRTUAL REAR SURROUND)
- ⑤② Multi rear surround button and indicator
(MULTI REAR SURROUND)
- ⑤③ Seat position button and indicator
(SEAT POSITION)

■ Operation Checks and Component Replacement Procedures

- NOTE** 1. This section describes procedures for checking the operation of the major printed circuit boards and replacing the main components.
2. For reassembly after operation checks or replacement, reverse the respective procedures. Special reassembly procedures are described only when required.

1. Checking for the FL P.C.B.

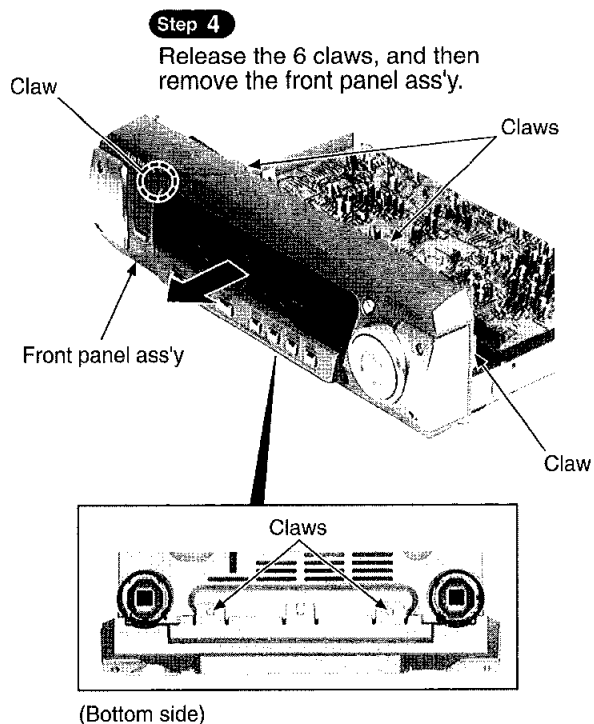
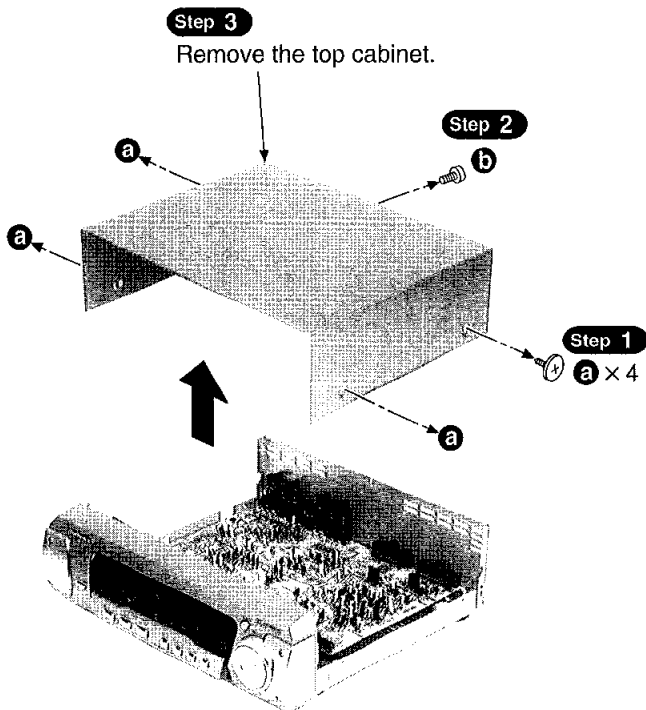

Step 5

Release the 5 claws, and then remove the FL P.C.B..

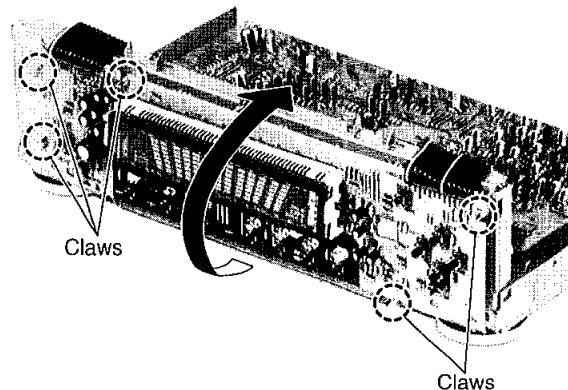

- Check the FL P.C.B. as shown below.

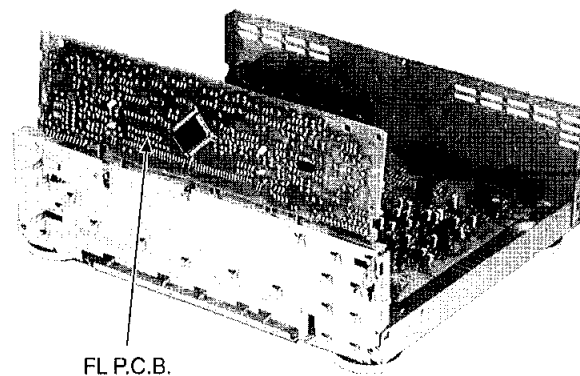

2. Checking for the main P.C.B.

- Follow the **Step 1** ~ **Step 3** of the item 1.

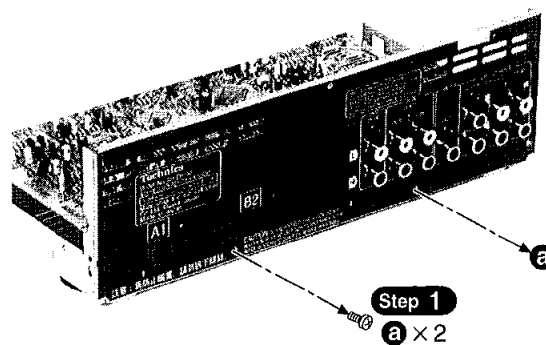

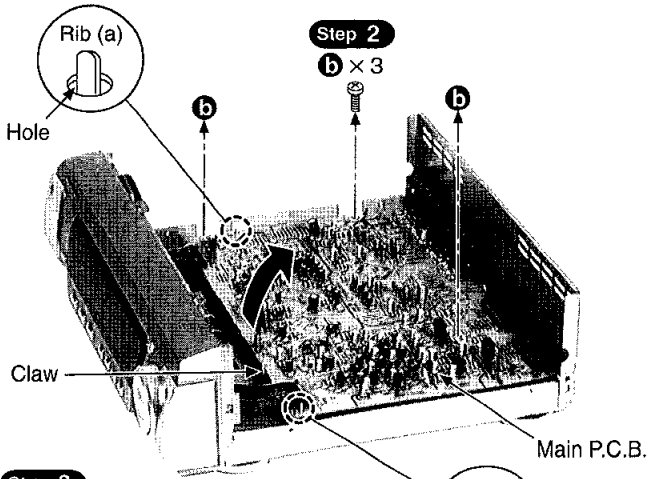

Step 3

Release the claw, and then lift up the main P.C.B.
 (Lift up the main P.C.B. until the rib (a) and rib (b) are released from the hole of main P.C.B..)

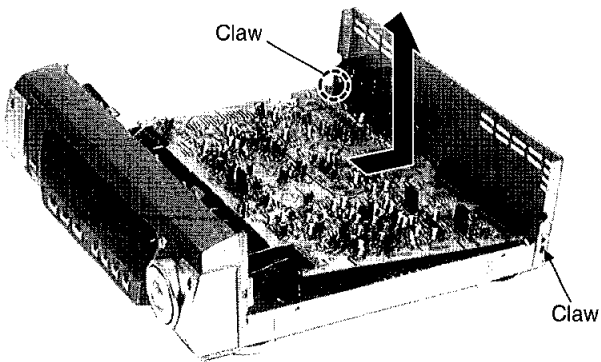
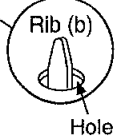

Step 4

Release the 2 claws, and then remove the main P.C.B. in the direction of arrow.

• Check the main P.C.B. as shown below.

Step 5

Insert the insulator sheet (paper etc).

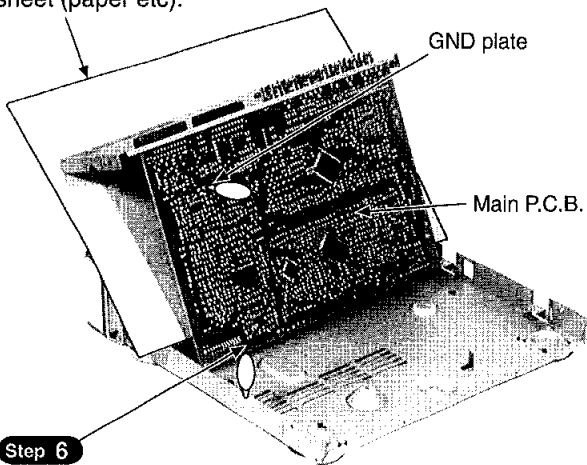

Step 6

Connect the lead wire.

■ Schematic Diagram

Page

A FL CIRCUIT	6,7
B MAIN CIRCUIT	8~14

- This schematic diagram may be modified at any time with the development of new technology.

Notes:

- **S601** : Display mode select switch (DISPLAY MODE)
- **S602** : DOLBY PRO LOGIC on/off switch (DOLBY PRO LOGIC OFF/ON)
- **S603** : Super surround switch (SUPER SURROUND)
- **S604** : Simulated stereo on/off button switch (SIMULATED STEREO)
- **S605** : Center focus switch (CENTER FOCUS)
- **S606** : Virtual rear surround switch (VIRTUAL REAR SURROUND)
- **S607** : Multi rear surround switch (MULTI REAR SURROUND)
- **S608** : Seat position switch (SEAT POSITION)
- **S609~S612** : JOY stick (S609 : ▶, S610 : ▲, S611 : ◀, S612 : ▼)
- **S613** : 3D AI EQ switch (3D AI EQ)
- **S651** : JOG control switch (MULTI JOG)

- Indicated voltage values are the standard values for the unit measured by the DC electronic circuit tester (high-impedance) with the chassis taken as standard. Therefore, there may exist some errors in the voltage values, depending on the internal impedance of the DC circuit tester.

- Important safety notice:

Components identified by \triangle mark have special characteristics important for safety.

Furthermore, special parts which have purposes of fire-retardant (resistors), high-quality sound (capacitors), low-noise (resistors), etc. are used. When replacing any of components, be sure to use only manufacturer's specified parts shown in the parts list.

- **Caution!**

IC and LSI are sensitive to static electricity.

Secondary trouble can be prevented by taking care during repair.

Cover the parts boxes made of plastics with aluminum foil.

Ground the soldering iron.

Put a conductive mat on the work table.

Do not touch the legs of IC or LSI with the fingers directly.

- **Voltage and signal line**

 : Positive voltage line

 : Negative voltage line

 : CD signal line

 : Surround SP.drive signal line

 : Center SP.drive signal line

SCHEMATIC DIAGRAM-1

NOTE: The number which noted at the connectors on the schematic diagram as "SCHEMATIC DIAGRAM-1" or "SCHEMATIC DIAGRAM-2" indicates the schematic diagram serial number located on the left corner in the schematic diagram.

→ POSITIVE VOLTAGE LINE
← NEGATIVE VOLTAGE LINE

A FL CIRCUIT

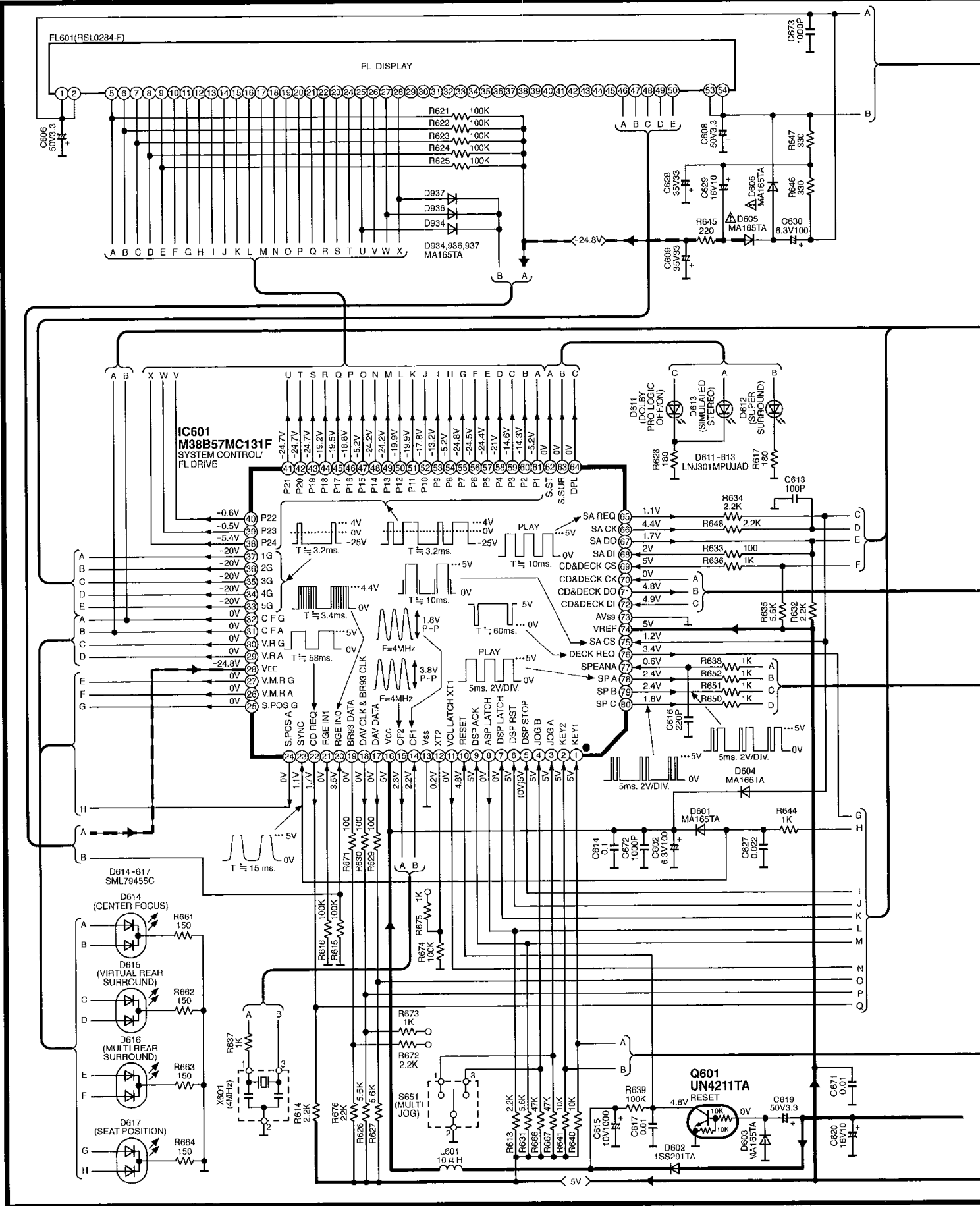

SCHEMATIC DIAGRAM-2

→ POSITIVE VOLTAGE LINE

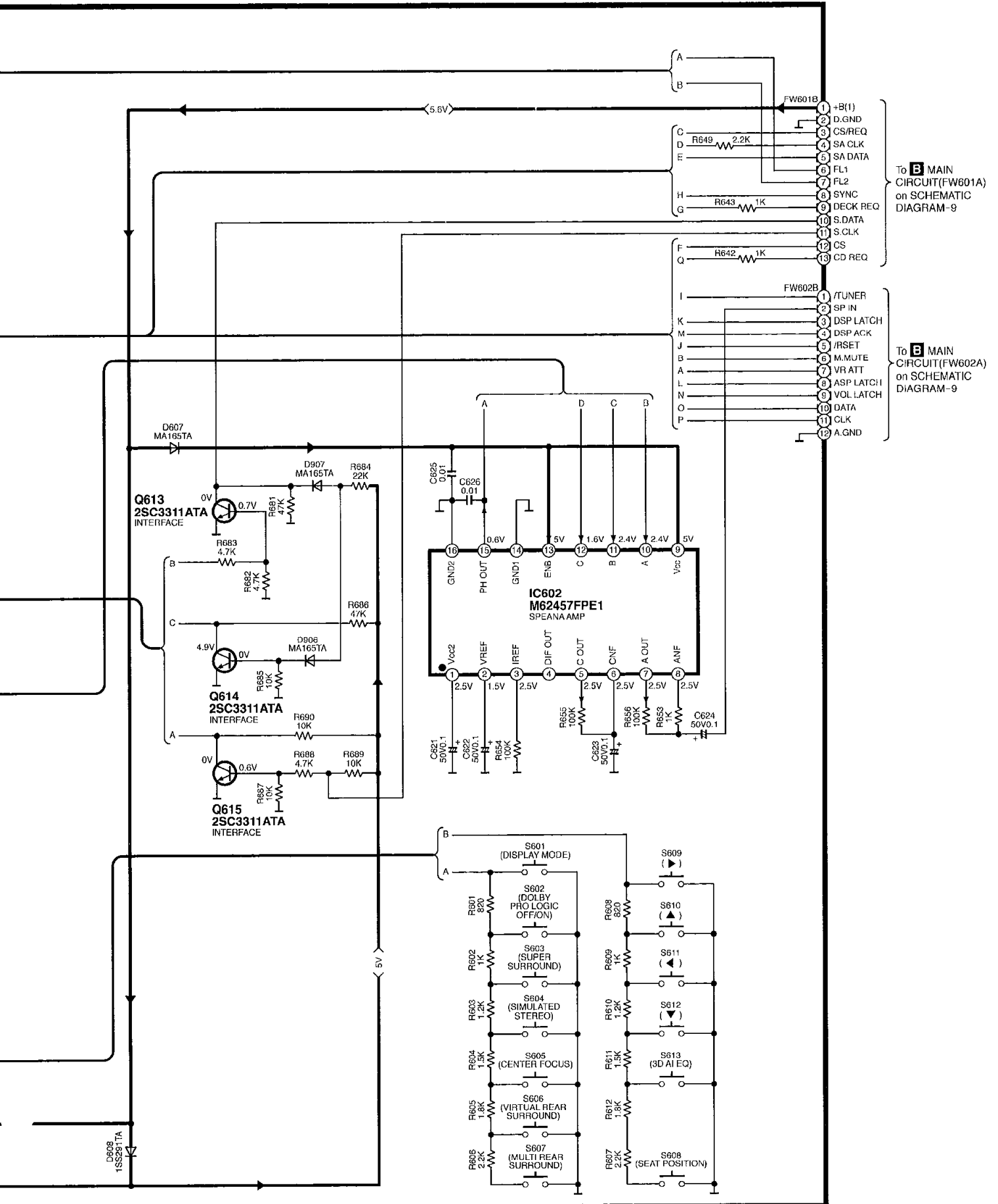

SCHEMATIC DIAGRAM-3

B MAIN CIRCUIT

: POSITIVE VOLTAGE LINE
 : NEGATIVE VOLTAGE LINE
 : CD SIGNAL LINE
 : CENTER SP. DRIVE SIGNAL LINE

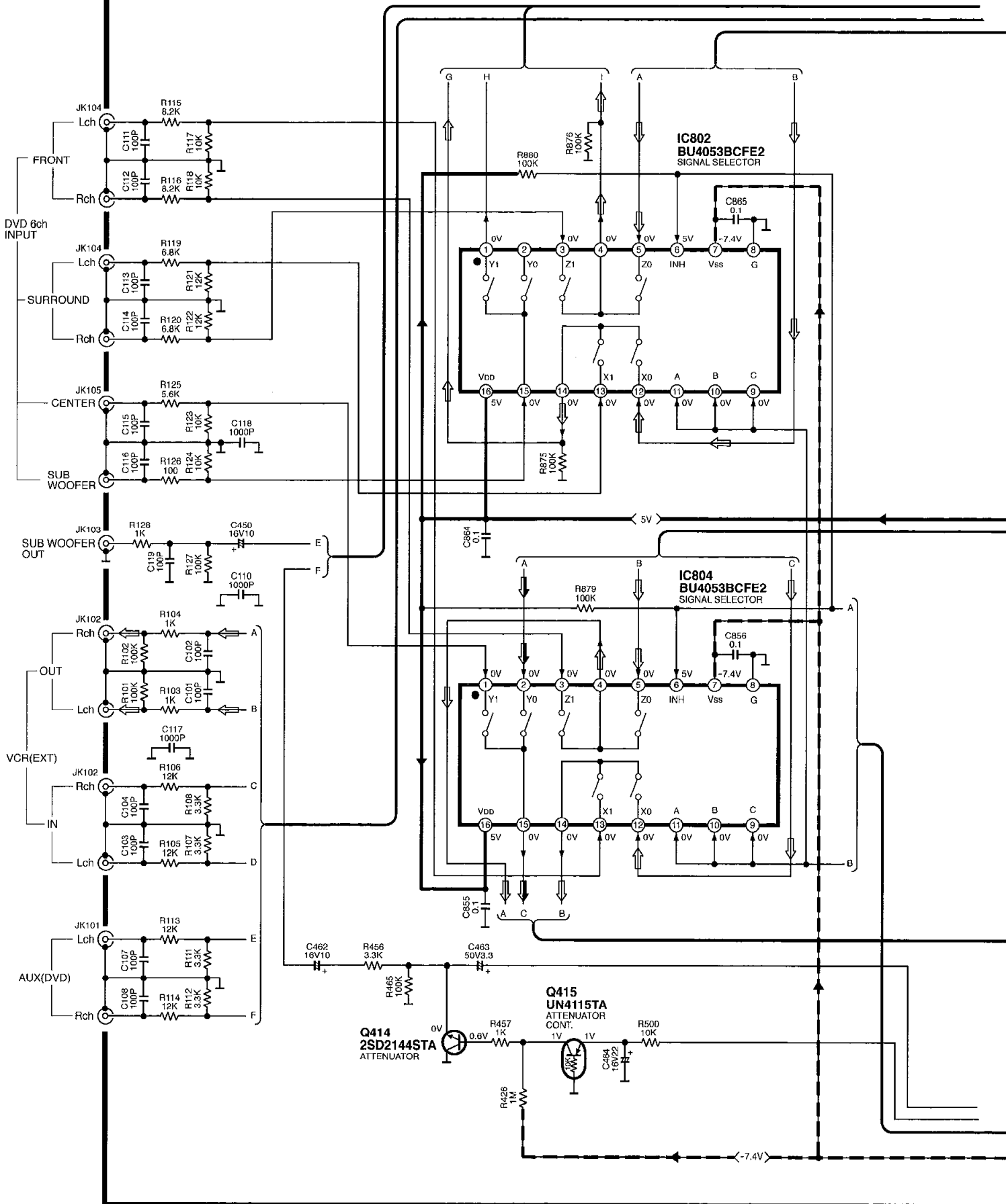

SCHEMATIC DIAGRAM-4

——— : POSITIVE VOLTAGE LINE ⇨ : CD SIGNAL LINE
 - - - : NEGATIVE VOLTAGE LINE ⇨ : SURROUND SP.DRIVE SIGNAL LINE ⇨ : CENTER SP.DRIVE SIGNAL LINE

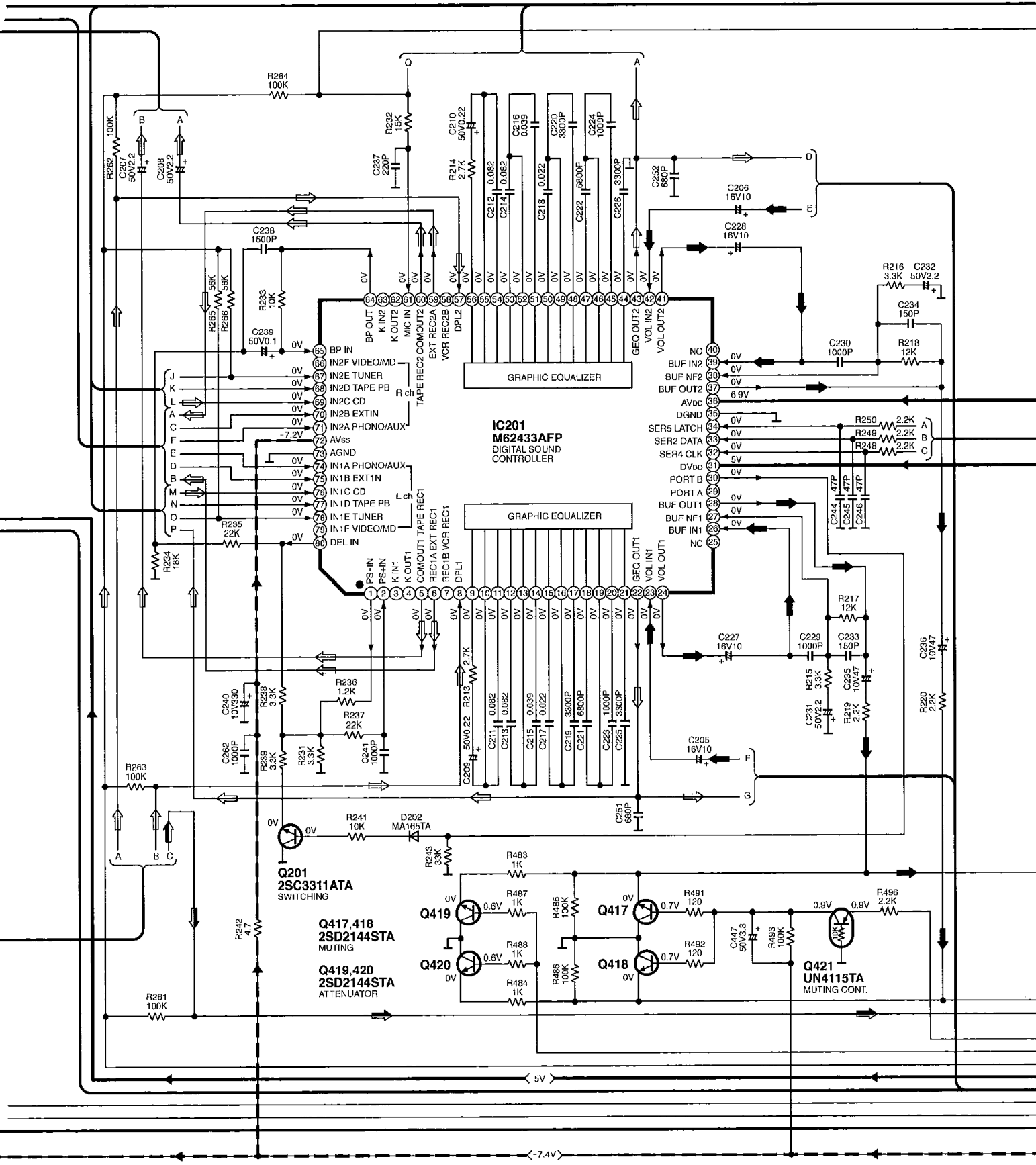

SCHEMATIC DIAGRAM-6

→ : POSITIVE VOLTAGE LINE
→ : NEGATIVE VOLTAGE LINE
⇨ : CD SIGNAL LINE
⇨ : CENTER SP.DRIVE SIGNAL LINE

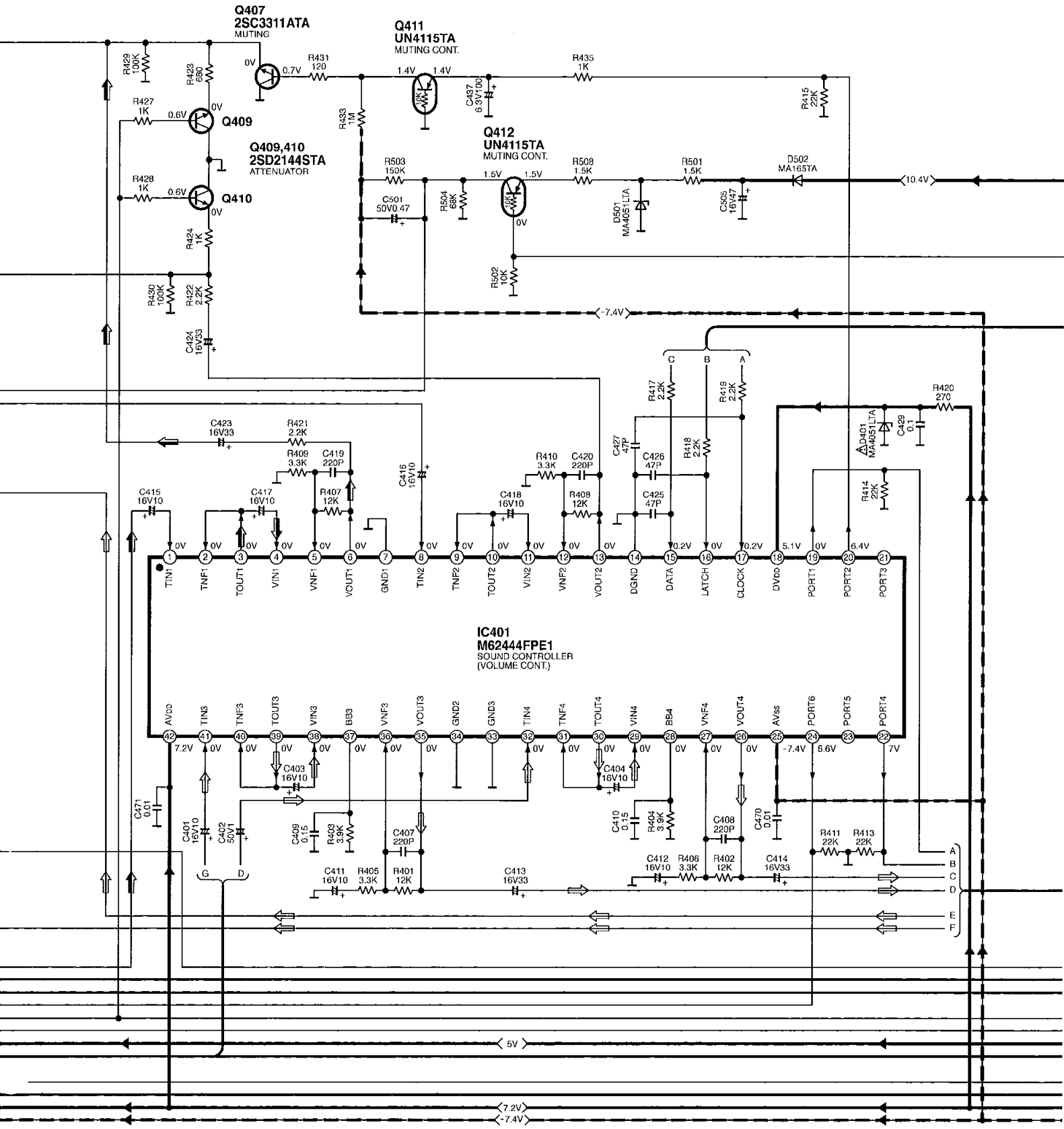

SCHEMATIC DIAGRAM-7

B MAIN CIRCUIT

—▶— : POSITIVE VOLTAGE LINE
 - - -▶- : NEGATIVE VOLTAGE LINE ◁ : CD SIGNAL LINE

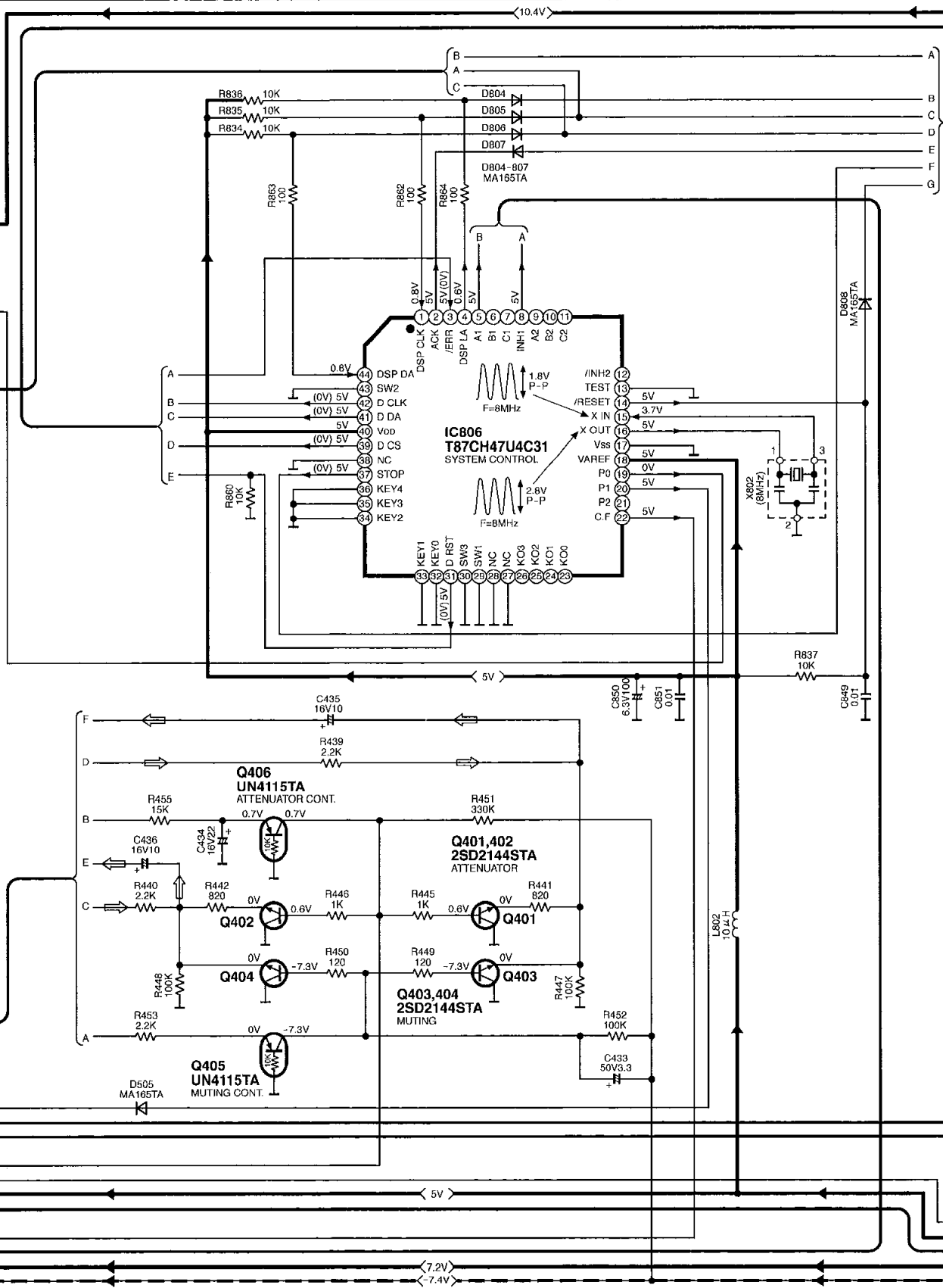

SCHEMATIC DIAGRAM-8

→ : POSITIVE VOLTAGE LINE ⇨ : CD SIGNAL LINE
- - -> : NEGATIVE VOLTAGE LINE ⇨ : SURROUND SP.DRIVE SIGNAL LINE ⇨ : CENTER SP.DRIVE SIGNAL LINE

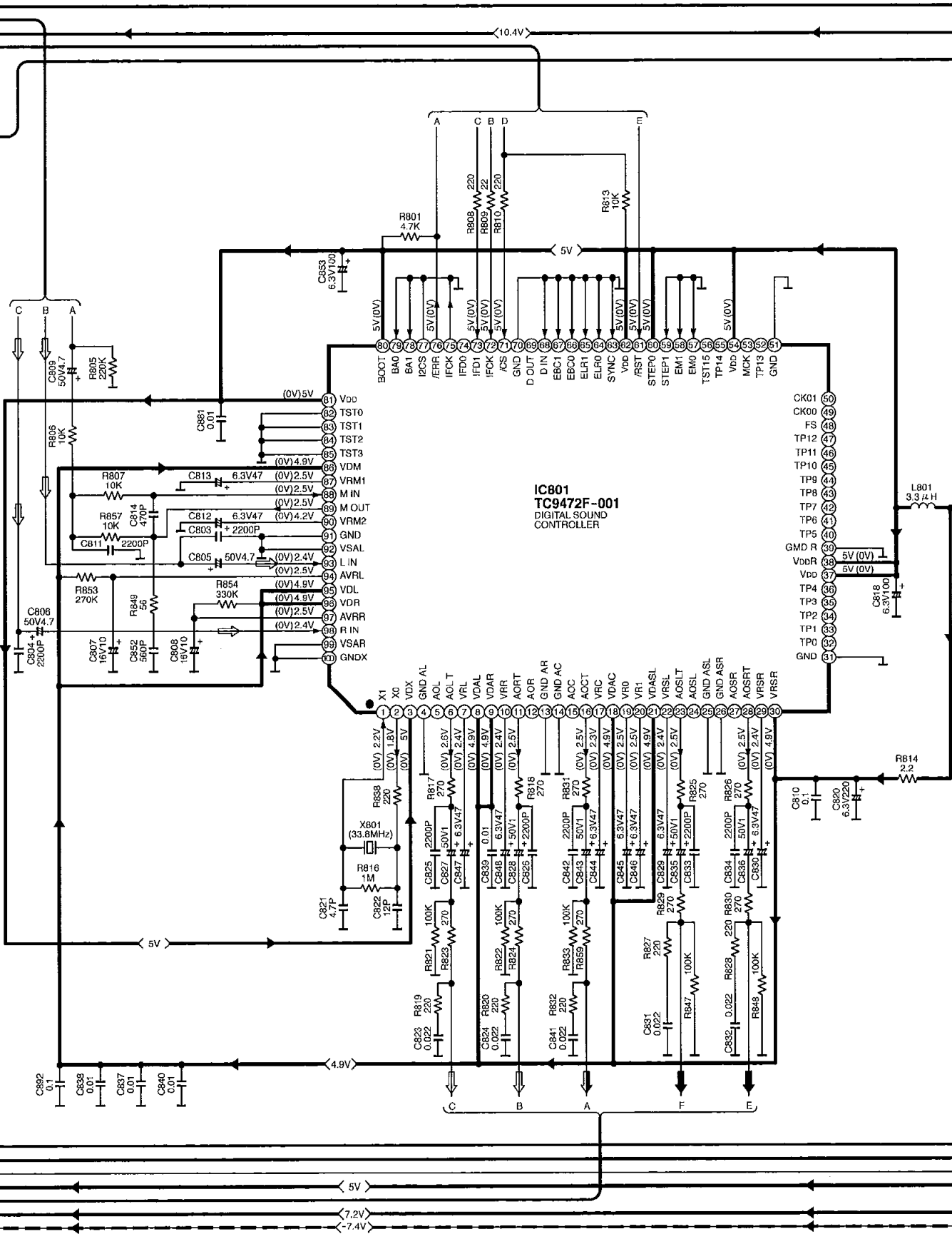

SCHEMATIC DIAGRAM-9

B MAIN CIRCUIT

: POSITIVE VOLTAGE LINE : NEGATIVE VOLTAGE LINE
 : CD SIGNAL LINE : SURROUND SP.DRIVE SIGNAL LINE : CENTER SP.DRIVE SIGNAL LINE

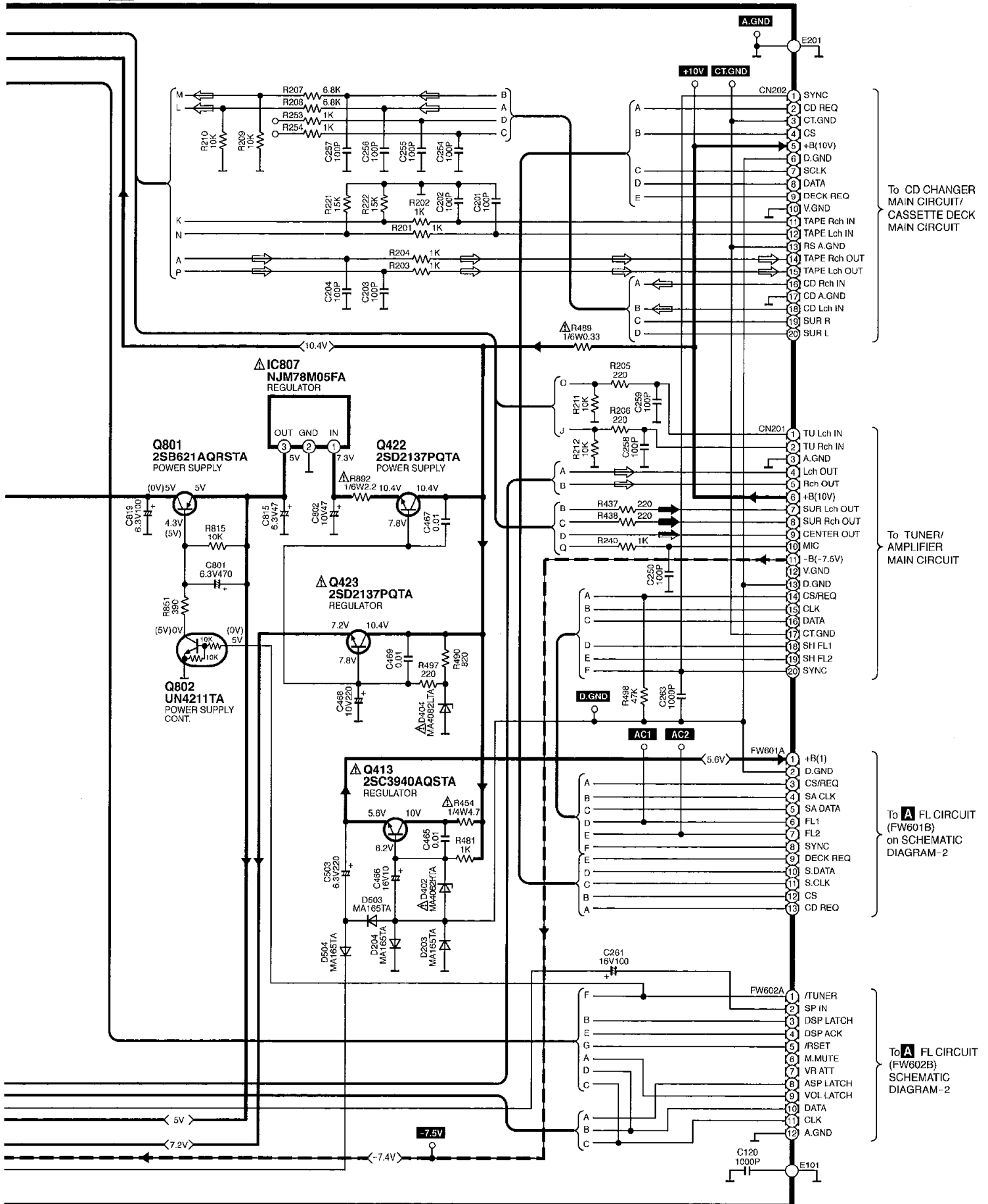

Printed Circuit Board Diagram

• This circuit board diagram may be modified at any time with the development of new technology.

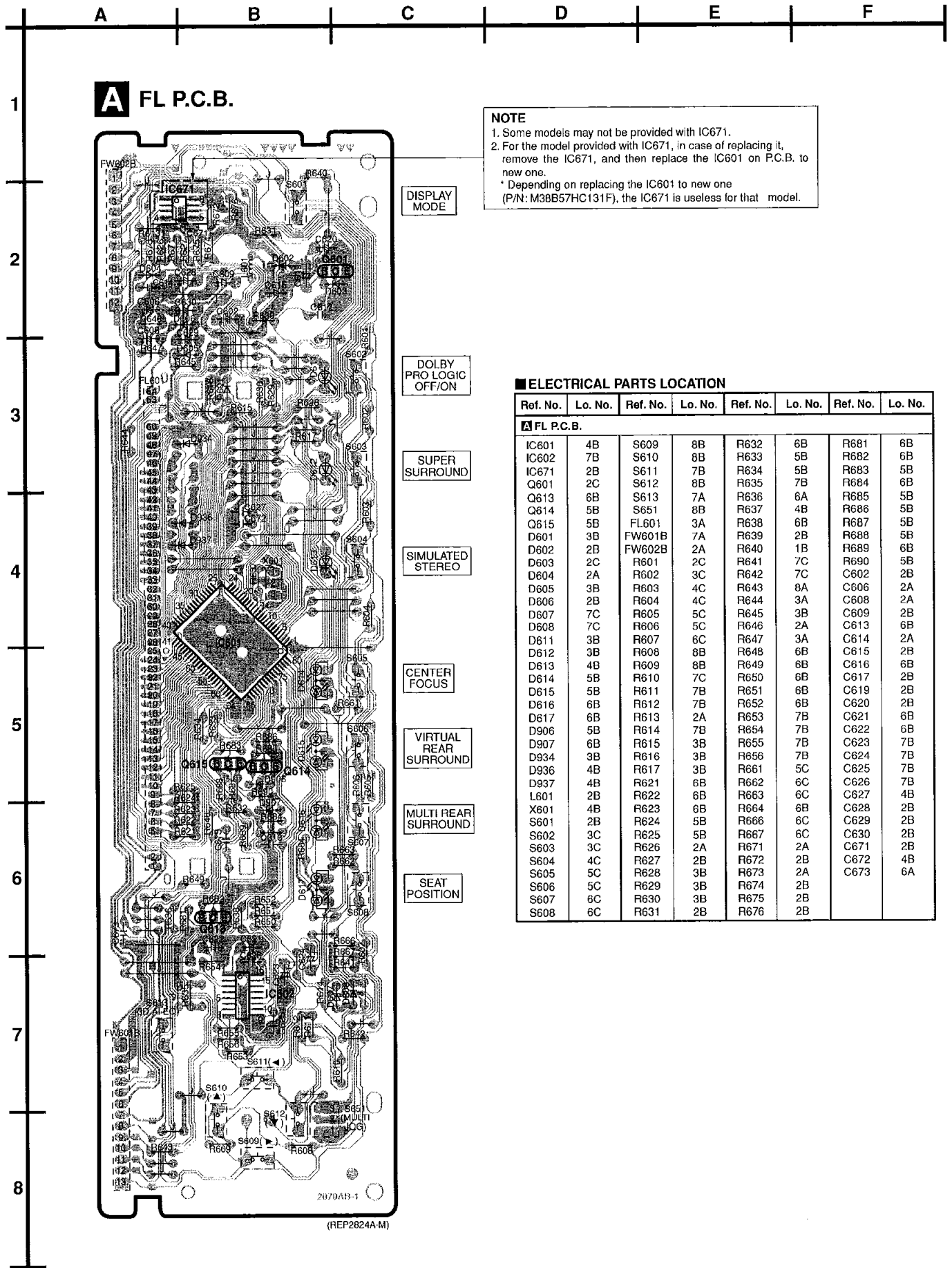

NOTE
 1. Some models may not be provided with IC671.
 2. For the model provided with IC671, in case of replacing it, remove the IC671, and then replace the IC601 on P.C.B. to new one.
 * Depending on replacing the IC601 to new one (P/N: M38B57HC131F), the IC671 is useless for that model.

ELECTRICAL PARTS LOCATION

Ref. No.	Lo. No.	Ref. No.	Lo. No.	Ref. No.	Lo. No.	Ref. No.	Lo. No.
A FL P.C.B.							
IC601	4B	S609	8B	R632	6B	R681	6B
IC602	7B	S610	8B	R633	5B	R682	6B
IC671	2B	S611	7B	R634	5B	R683	5B
Q601	2C	S612	8B	R635	7B	R684	6B
Q613	6B	S613	7A	R636	6A	R685	5B
Q614	5B	S651	8B	R637	4B	R686	5B
Q615	5B	FL601	3A	R638	6B	R687	5B
D601	3B	FW601B	7A	R639	2B	R688	5B
D602	2B	FW602B	2A	R640	1B	R689	6B
D603	2C	R601	2C	R641	7C	R690	5B
D604	2A	R602	3C	R642	7C	C602	2B
D605	3B	R603	4C	R643	8A	C606	2A
D606	2B	R604	4C	R644	3A	C608	2A
D607	7C	R605	5C	R645	3B	C609	2B
D608	7C	R606	5C	R646	2A	C613	6B
D611	3B	R607	6C	R647	3A	C614	2A
D612	3B	R608	8B	R648	6B	C615	2B
D613	4B	R609	8B	R649	6B	C616	6B
D614	5B	R610	7C	R650	6B	C617	2B
D615	5B	R611	7B	R651	6B	C619	2B
D616	6B	R612	7B	R652	6B	C620	2B
D617	6B	R613	2A	R653	7B	C621	6B
D906	5B	R614	7B	R654	7B	C622	6B
D907	6B	R615	3B	R655	7B	C623	7B
D934	3B	R616	3B	R656	7B	C624	7B
D936	4B	R617	3B	R661	5C	C625	7B
D937	4B	R621	6B	R662	6C	C626	7B
L601	2B	R622	6B	R663	6C	C627	4B
X601	4B	R623	6B	R664	6B	C628	2B
S601	2B	R624	5B	R666	6C	C629	2B
S602	3C	R625	5B	R667	6C	C630	2B
S603	3C	R626	2A	R671	2A	C671	2B
S604	4C	R627	2B	R672	2B	C672	4B
S605	5C	R628	3B	R673	2A	C673	6A
S606	5C	R629	3B	R674	2B		
S607	6C	R630	3B	R675	2B		
S608	6C	R631	2B	R676	2B		

A B C D E F

1

B MAIN P.C.B.

2

3

4

5

6

7

8

DVD 6ch INPUT

FRONT

SURROUND

CENTER

SUB WOOFER

SUBWOOFER OUT

(IN)

VCR (EXT)

(OUT)

AUX(DVD)

+10V

To CD CHANGER/
CASSETTE DECK

-7.5V

A. GND

To TUNER/
AMPLIFIER

AC2 AC1 CT. GND D. GND

2070AA-1

(REP2024A-M)



■ ELECTRICAL PARTS LOCATION

Ref. No.	Lo. No.	Ref. No.	Lo. No.	Ref. No.	Lo. No.	Ref. No.	Lo. No.	Ref. No.	Lo. No.	Ref. No.	Lo. No.	Ref. No.	Lo. No.	Ref. No.	Lo. No.
■ MAIN P.C.B.															
IC201	4C	JK102	3A	R242	5C	R460	6C	R823	3D	C203	5B	C409	7D	C807	3F
IC401	6E	JK103	3A	R243	5C	R461	8C	R824	3D	C204	6B	C410	7D	C808	3E
IC402	6F	JK104	2A	R248	4D	R462	8C	R825	4D	C205	2D	C411	7D	C809	3F
IC403	7C	JK105	2A	R249	4D	R463	8C	R826	4D	C206	2C	C412	6D	C810	4F
IC404	6C	FW601A	7F	R250	6E	R464	8C	R827	5D	C207	3C	C413	7D	C811	3F
IC801	4E	FW602A	2F	R251	2D	R465	7C	R828	5D	C208	3C	C414	7E	C812	4F
IC802	2E	E101	1C	R252	2D	R466	6C	R829	5D	C209	5C	C415	6D	C813	4F
IC803	2F	E201	6C	R253	5B	R467	6C	R830	5D	C210	3C	C416	6D	C814	4E
IC804	2D	R101	4B	R254	6C	R468	6C	R831	4E	C211	5C	C417	7E	C815	5F
IC806	5E	R102	4B	R261	2F	R469	6C	R832	3E	C212	3C	C418	6E	C818	5E
IC807	5F	R103	4B	R262	2F	R470	6C	R833	3E	C213	5C	C419	7E	C819	4F
Q201	5C	R104	4B	R263	2F	R471	6C	R834	5E	C214	3C	C420	6E	C820	4F
Q401	7D	R105	3B	R264	4C	R472	6F	R835	5F	C215	5C	C421	7C	C821	4E
Q402	8D	R106	3B	R265	5B	R473	7F	R836	5F	C216	2C	C422	7C	C822	3E
Q403	7D	R107	3B	R266	5B	R474	6F	R837	6E	C217	5C	C423	7E	C823	3D
Q404	7D	R108	3B	R401	7D	R475	7F	R838	3E	C218	2C	C424	6E	C824	3D
Q405	7D	R111	4B	R402	6D	R476	7F	R839	3E	C219	5C	C425	6E	C825	3E
Q406	7E	R112	4B	R403	7D	R477	7C	R840	3E	C220	2C	C426	6D	C826	3E
Q407	7E	R113	4B	R404	7D	R478	8C	R847	5E	C221	5C	C427	6E	C827	3E
Q408	7E	R114	4B	R405	7D	R479	7C	R848	5D	C222	2C	C428	7F	C828	3E
Q409	8E	R115	1B	R406	6D	R480	7C	R849	4F	C223	5C	C429	6E	C829	4D
Q410	7E	R116	2B	R407	7E	R481	8D	R851	5E	C224	2C	C430	6C	C830	4D
Q411	7E	R117	2B	R408	6E	R483	5D	R853	3E	C225	5C	C433	8D	C831	5E
Q412	6E	R118	2B	R409	7E	R484	4D	R854	3E	C226	2C	C434	7E	C832	5D
Q413	8D	R119	2B	R410	6E	R485	5D	R857	4F	C227	4C	C435	7D	C833	4D
Q414	7C	R120	2B	R411	7E	R486	4D	R859	3E	C228	3C	C436	7D	C834	4D
Q415	7C	R121	2B	R413	7E	R487	5D	R860	6F	C229	4D	C437	8E	C835	4D
Q417	5D	R122	2B	R414	6E	R488	4D	R862	5F	C230	3D	C438	6C	C836	5D
Q418	4D	R123	2B	R415	6E	R489	7B	R863	5F	C231	5C	C439	7C	C837	4D
Q419	5D	R124	2B	R417	6E	R490	8B	R864	5F	C232	3D	C440	7C	C838	4D
Q420	4D	R125	2B	R418	6D	R491	5D	R870	4F	C233	5D	C443	7E	C839	4E
Q421	7D	R126	3B	R419	6E	R492	4D	R871	4F	C234	3D	C444	6F	C840	4D
Q422	7B	R127	3B	R420	6E	R493	7D	R872	3F	C235	5C	C445	7C	C841	3D
Q423	7C	R128	3B	R421	7E	R496	8D	R873	3F	C236	3D	C446	7C	C842	4E
Q424	8C	R201	5B	R422	6E	R497	8B	R874	3E	C237	3C	C447	7D	C843	3E
Q425	8C	R202	5B	R423	7E	R498	8B	R875	3E	C238	3C	C450	3B	C844	3D
Q501	7E	R203	6B	R424	7E	R499	8C	R876	3E	C239	3C	C451	6F	C845	3D
Q801	4F	R204	6B	R425	8C	R500	8D	R877	3E	C240	5C	C452	6F	C846	3D
Q802	5E	R205	7B	R426	7C	R501	6F	R878	3F	C241	5C	C453	7F	C847	3E
D201	2D	R206	7B	R427	8E	R502	6E	R879	2E	C242	3D	C454	7F	C848	3E
D202	5C	R207	6C	R428	8E	R503	8E	R880	2E	C243	3D	C455	6F	C849	6F
D203	7B	R208	6B	R429	7E	R504	8E	R892	6F	C244	3D	C458	6C	C850	6F
D204	7B	R209	5B	R430	7E	R505	7E	R893	3E	C245	3D	C460	6F	C851	6E
D401	6E	R210	5B	R431	7E	R506	7E	R894	3F	C246	3D	C461	6C	C852	4E
D402	8E	R211	6B	R433	7E	R507	7F	R895	3E	C247	2D	C462	7C	C853	4E
D404	8B	R212	7B	R435	7E	R508	6E	R896	3E	C250	7B	C463	6C	C854	3F
D405	5B	R213	4C	R437	6C	R513	7E	R897	3E	C251	4D	C464	8C	C855	3D
D406	5C	R214	3C	R438	6C	R514	7E	R898	3E	C252	2C	C465	8D	C856	2E
D501	6E	R215	5D	R439	6C	R801	5F	C101	4B	C253	2D	C466	8E	C864	2E
D502	8E	R216	3D	R440	7D	R803	3E	C102	4B	C254	6B	C467	8B	C865	2E
D503	8E	R217	5C	R441	7D	R804	3E	C103	3B	C255	6B	C468	8B	C866	3F
D504	8D	R218	3D	R442	7D	R805	3F	C104	3B	C256	6B	C469	7C	C867	3E
D505	8C	R219	5D	R445	8D	R806	3F	C107	4B	C257	6B	C470	6D	C868	3F
D804	5E	R220	3D	R446	8D	R807	4F	C108	4B	C258	7B	C471	7D	C869	3E
D805	5F	R221	4C	R447	7D	R808	5E	C110	3B	C259	7B	C472	6F	C870	2F
D806	5E	R222	4C	R448	7D	R809	5E	C111	1B	C261	2F	C473	6C	C871	3E
D807	5E	R231	4C	R449	7D	R810	5E	C112	2B	C262	4C	C474	6C	C872	3E
D808	6F	R232	3C	R450	7D	R813	5E	C113	2B	C263	8F	C501	8E	C873	3E
L401	7C	R233	3B	R451	7E	R814	4F	C114	2B	C276	8C	C502	7F	C874	3E
L402	7C	R234	3B	R452	8D	R815	5E	C115	2B	C401	7D	C503	8E	C881	4E
L801	4E	R235	3B	R453	7D	R816	4E	C116	3B	C402	6D	C505	7F	C892	4E
L802	5F	R236	4C	R454	8D	R817	3E	C117	4B	C403	7D	C801	5F		
X801	3E	R237	4C	R455	7E	R818	3E	C118	2B	C404	7D	C802	6F		
X802	6E	R238	4C	R456	6C	R819	3D	C119	3B	C405	7C	C803	3E		
CN201	7B	R239	4C	R457	7C	R820	3D	C120	2B	C406	7C	C804	3E		
CN202	6B	R240	7B	R458	7C	R821	3E	C201	6B	C407	7D	C805	3E		
JK101	4A	R241	5C	R459	7C	R822	3E	C202	6B	C408	6D	C806	3E		

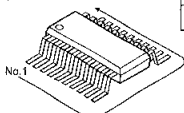
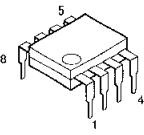
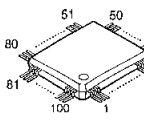
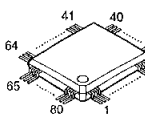
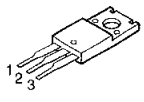
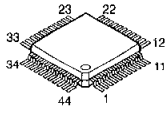
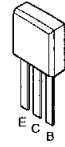
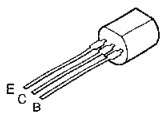
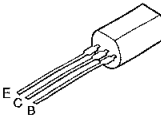
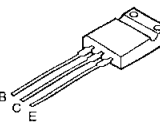
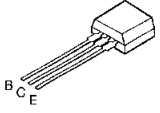
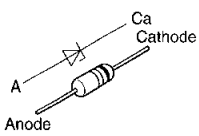
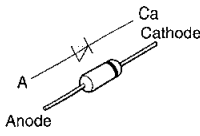
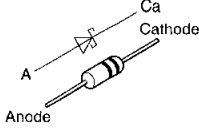
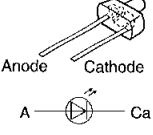
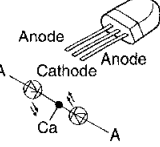
■ Type Illustration of IC's, Transistors and Diodes

 <table border="1" data-bbox="279 179 510 291"> <tr><td>BU4053BCFE2</td><td>16PIN</td></tr> <tr><td>M5218AFPE3</td><td>8PIN</td></tr> <tr><td>M62444FFPE1</td><td>42PIN</td></tr> <tr><td>M62457FFPE1</td><td>16PIN</td></tr> </table>	BU4053BCFE2	16PIN	M5218AFPE3	8PIN	M62444FFPE1	42PIN	M62457FFPE1	16PIN	<p>M5218AP</p> 	<p>TC9472F-001</p> 	<p>M38B57MC131F M62433AFP</p> 	<p>NJM78M05FA</p> 
BU4053BCFE2	16PIN											
M5218AFPE3	8PIN											
M62444FFPE1	42PIN											
M62457FFPE1	16PIN											
<p>T87CH47U4C31</p> 	 <p>2SC3311ATA UN4115TA UN4211TA</p>		<p>2SB621AQRSTA</p> 	<p>2SC3940AQSTA</p> 	<p>2SD2137PQTA</p> 							
<p>2SD2144STA</p> 	<p>MA4051LTA MA4062HTA MA4082LTA</p> 	<p>MA165TA 1SS291TA</p> 	<p>MA719TA</p> 	<p>LNJ301MPUJAD</p> 	<p>SML79455C</p> 							

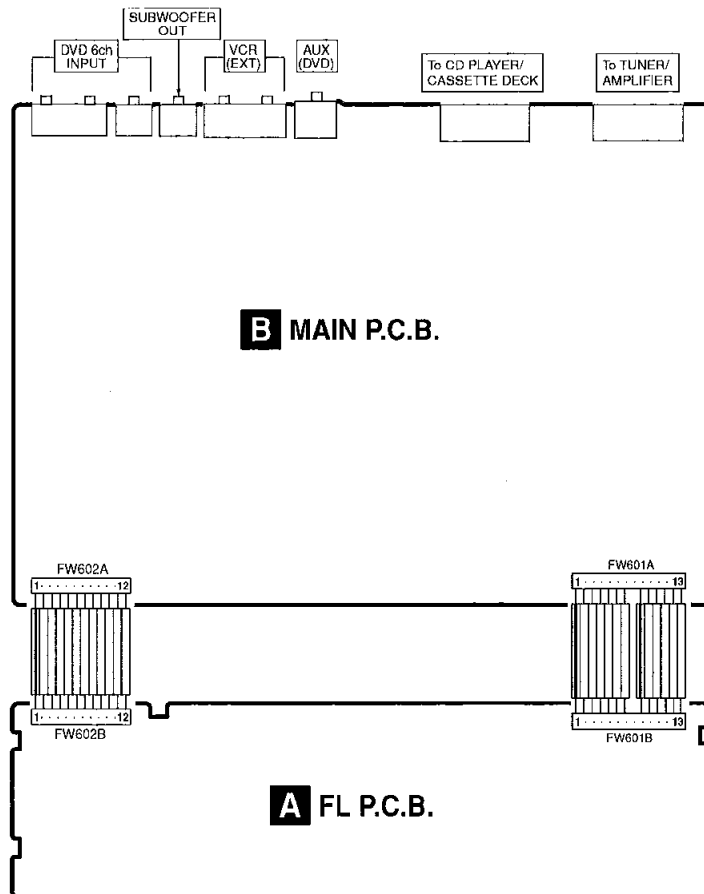
■ Wiring Connection Diagram



■ Terminal Function of IC's

● IC601 (M38B57MC131F) : System Control/ FL Drive

Pin No.	Terminal Name	I/O	Function
1	KEY1	I	Operation key signal input
2	KEY2	I	Operation key signal input
3	JOGA	I	JOG A signal input
4	JOGB	I	JOG B signal input
5	DSP STOP	I	Stop signal input for IC806
6	DSP RST	I	Reset signal input for IC806
7	DSP LATCH	I	Latch signal input for IC806
8	ASP LATCH	O	Latch signal output for IC201
9	DSP ACK	I	Acknowledge signal input for IC806
10	RESET	I	System reset signal input
11	VOL LATCH XT1	O	Latch signal output for IC401
12	XT2	-	EEPROM chip select signal (Not used)
13	Vss	-	GND terminal
14	CF1	I	Oscillator connected terminal (4 MHz)
15	CF2	O	
16	Vcc	I	Power supply (+5 V) terminal
17	DAV DATA	O	Volume data signal output
18	DAV CLK & BR93 CLK	O	Volume clock signal output
19	BR93 DATA	-	EEPROM data input (Not used)
20	RGEIN0	I	Destination select signal input
21	RGEIN1	I	Destination select signal input
22	CD REQ	O	CD serial data request signal output
23	SYNC	I	Power failure detect signal input
24	S. POS A	O	ORANGE LED (SEAT POSITION) signal output
25	S. POS G	O	GREEN LED (SEAT POSITION) signal output
26	V.M.R A	O	ORANGE LED (MULTI REAR) signal output
27	V.M.R G	O	GREEN LED (MULTI REAR) signal output

Pin No.	Terminal Name	I/O	Function
28	V _{EE}	I	Power supply (-24.8 V) terminal
29	V.R A	O	ORANGE LED (VIRTUAL REAR) signal output
30	V.R G	O	GREEN LED (VIRTUAL REAR) signal output
31	C.F A	O	ORANGE LED (CENTER FOCUS) signal output
32	C.F G	O	GREEN LED (CENTER FOCUS) signal output
33~37	5G~1G	O	Grid signal output
38~61	P24~P1	O	Segment signal output
62	S.ST	O	LED (SIMULATED STEREO) signal output
63	S.SUR	O	LED (SUPER SURROUND STEREO) signal output
64	DPL	O	LED (DOLBY PRO LOGIC) signal output
65	SA REQ	O	Request signal output for Tuner/Amplifier
66	SA CK	O	Serial communication signal to Tuner/Amplifier (Clock signal output)
67	SA DO	O	Serial communication signal to Tuner/Amplifier (Data signal output)
68	SA DI	I	Serial communication signal to Tuner/Amplifier (Data signal input)
69	CD&DECK CS	I	Serial data communication starting signal input (CD and Deck mechanism)
70	CD&DECK CK	I	Clock signal input (CD and Deck mechanism)
71	CD&DECK DO	O	Data signal output (CD and Deck mechanism)
72	CD&DECK DI	I	Data signal input (CD and Deck mechanism)
73	AVss	-	GND terminal
74	VREF	I	Reference voltage input
75	SA CS	I	Chip select signal input terminal
76	DECK REQ	O	Serial data request signal output for Deck mechanism
77	SPEANA	I	A/D signal input for IC602
78	SP A	O	Band select signal output for IC602
79	SP B		
80	SP C		

Block Diagram

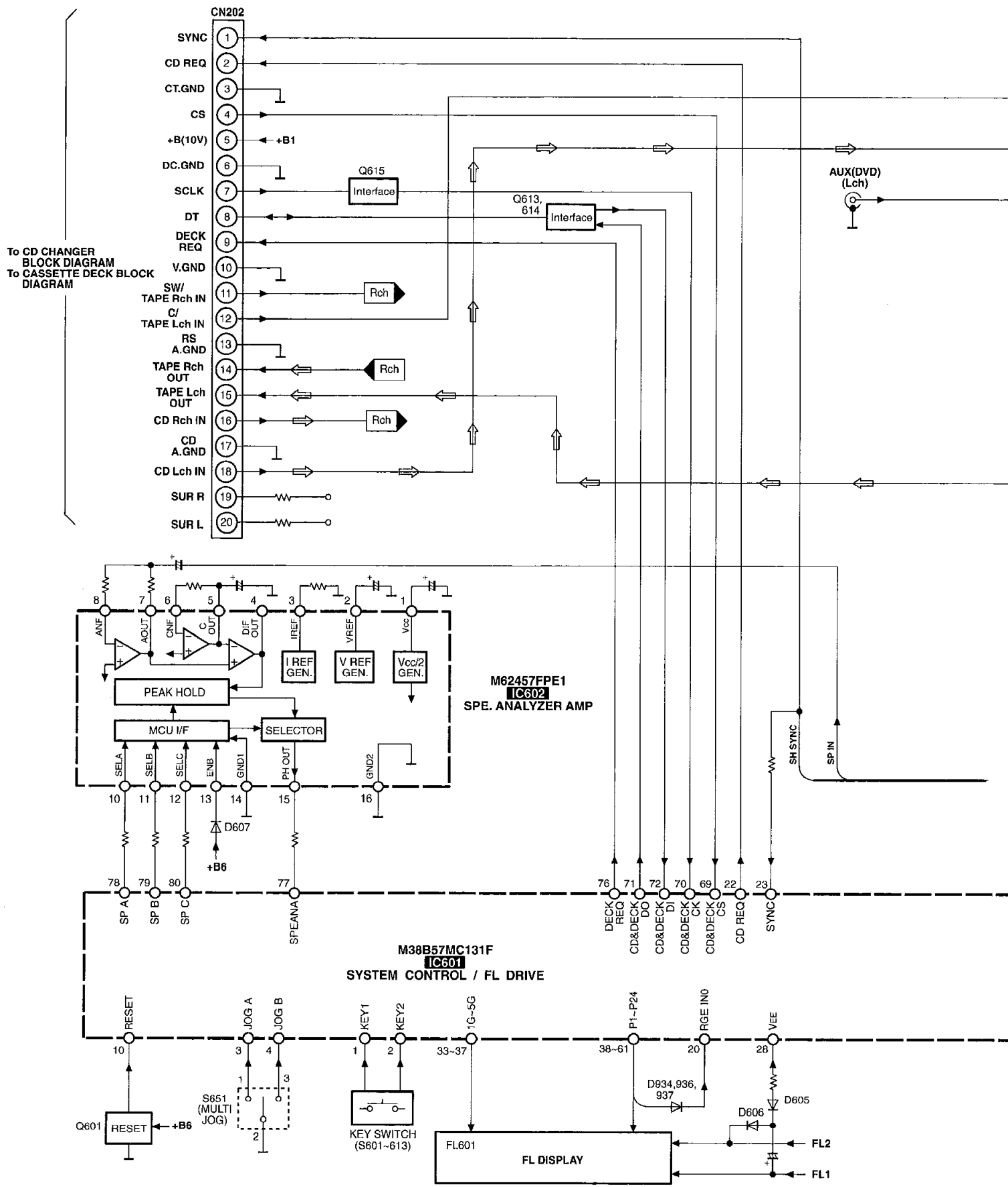

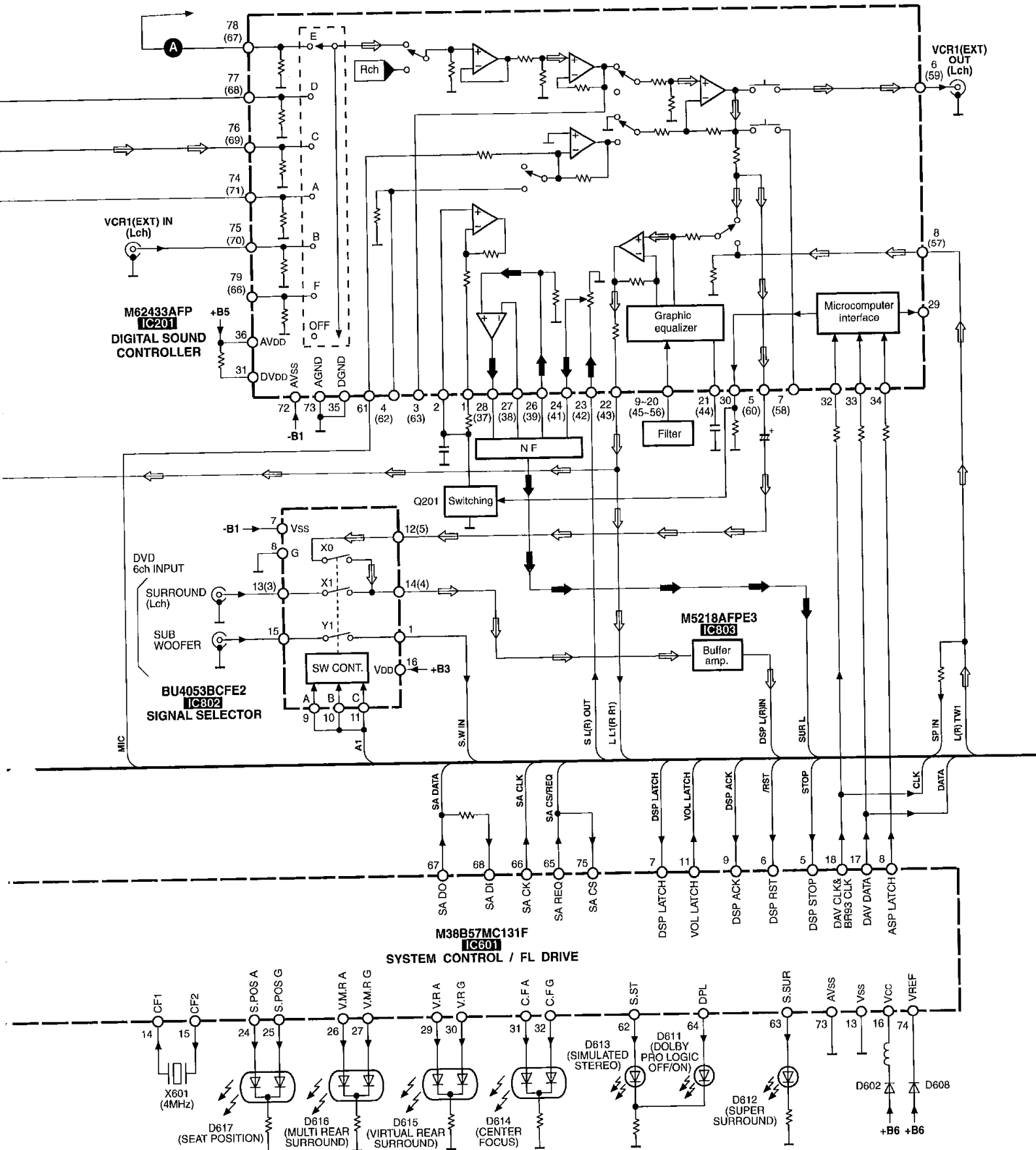

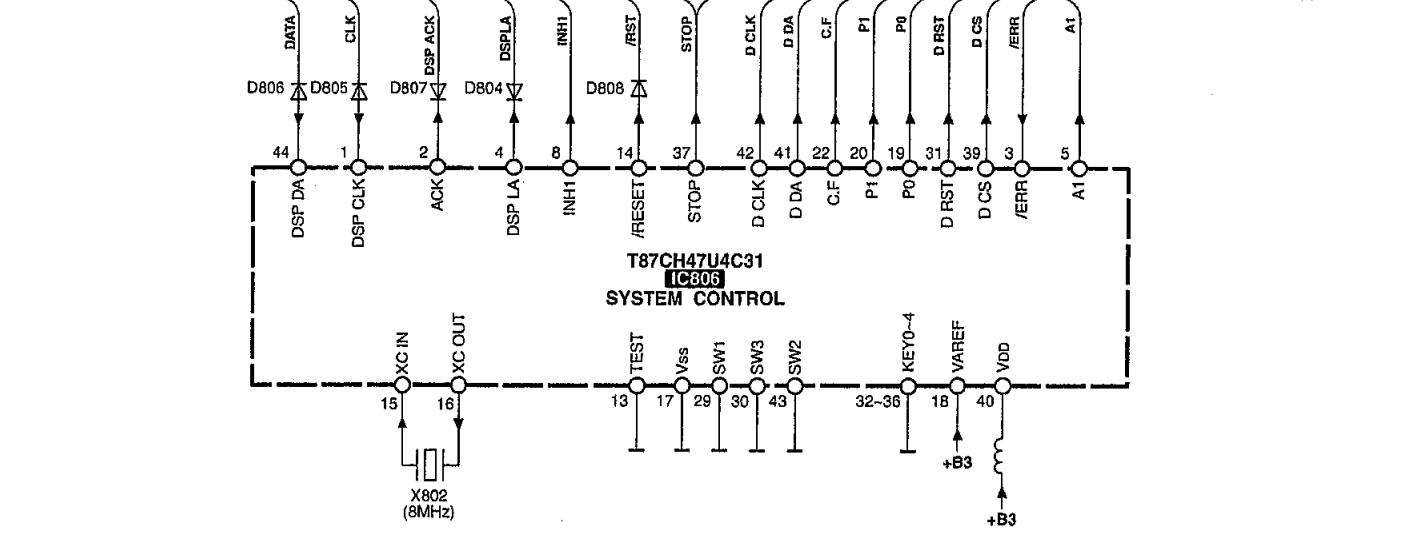
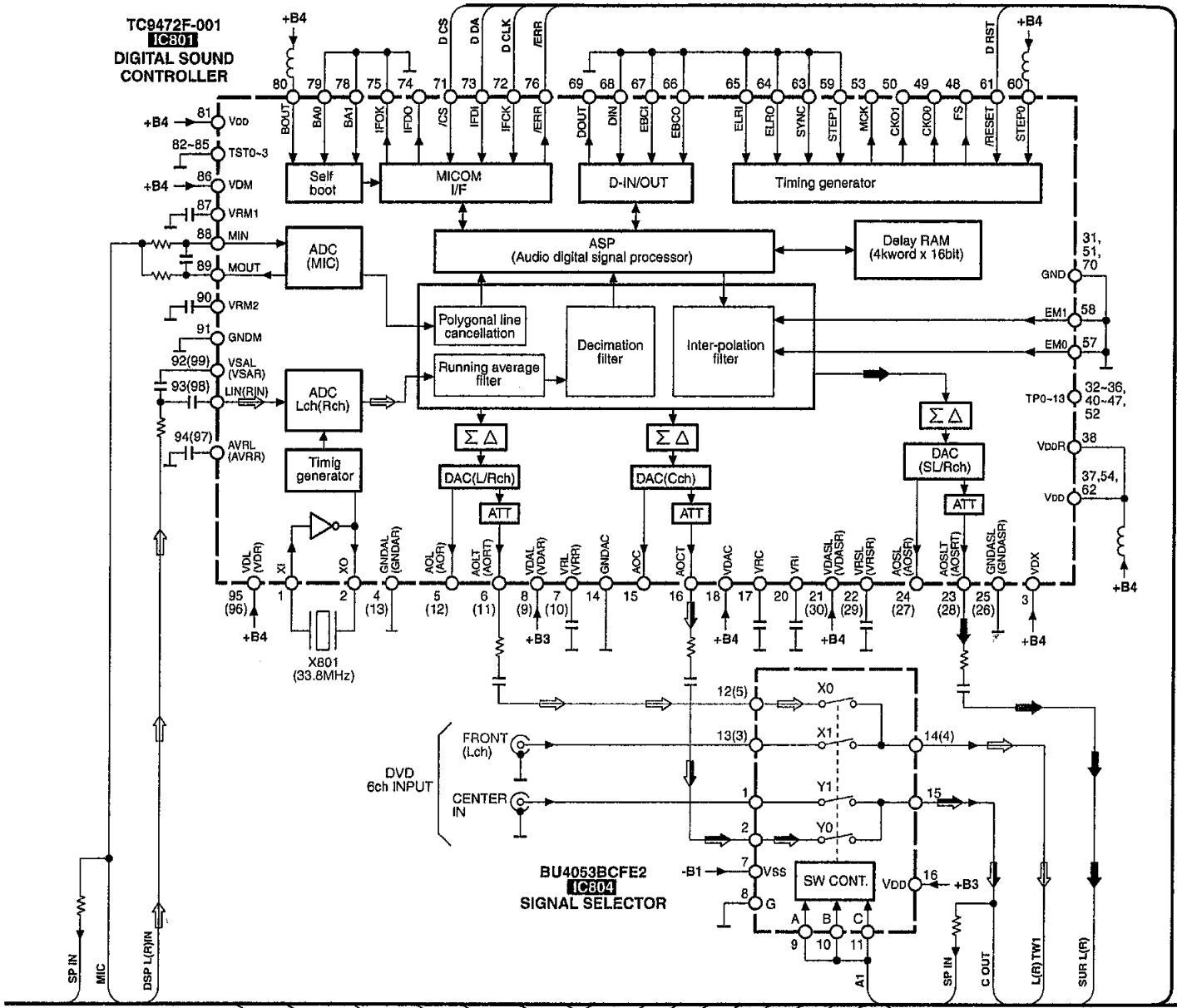

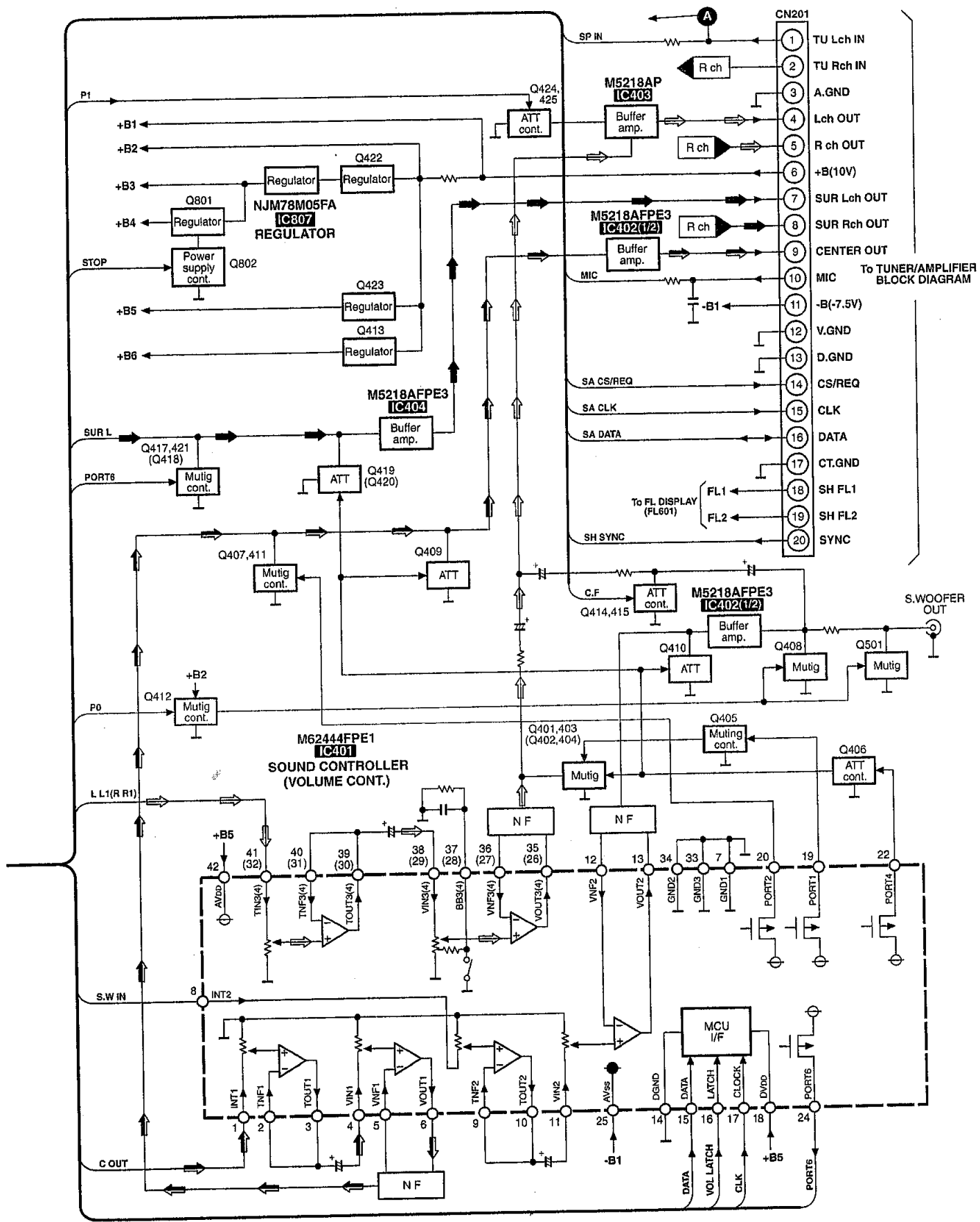

To TUNER/AMPLIFIER BLOCK DIAGRAM

Notes 1) \Rightarrow : CD signal line \Rightarrow : Surround SP. drive signal line \Rightarrow : Center SP. drive signal line
 2) () Indicates pin No. of right channel.