

AD0003058C2

# Service Manual

Mini Disc Deck



**SJ-HD515**

**Mechanism Unit: MR3A**

**Colour**

**(S).....Silver Type**

**Area**

**(E).....Europe.**

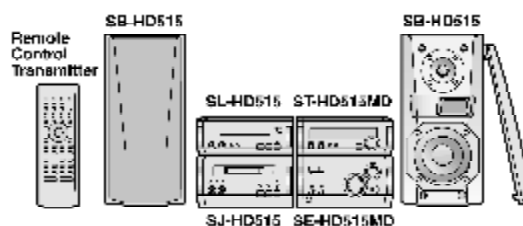

## SPECIFICATIONS

Because of unique interconnecting cables, when a component requires service, send or bring in the entire system.

System	SC-HD515MD
Tuner	ST-HD515MD
Amplifier	SE-HD515MD
CD Player	SL-HD515
MD Deck	SJ-HD515
Speakers*	SB-HD515

\* : Made in Spain.

**Specifications**

<b>Digital input/output terminal</b>		<b>General</b>	
Input:	Opticalx2	<b>Dimensions (W×H×D):</b>	200×104.5×253 mm
Output:	None	<b>Weight:</b>	1.4 kg
<b>Format</b>		<b>Notes:</b> Specifications are subject to change without notice.	
Sampling Frequency:	44.1 kHz	Weight and dimensions are approximate.	
Sampling Late Converter			
<b>Pickup</b>			
Wavelength:	780 nm		

© 2000 Matsushita Electric Industrial Co., Ltd. All rights reserved.  
 Unauthorized copying and distribution is a violation of law.

**⚠ WARNING**

This service information is designed for experienced repair technicians only and is not designed for use by the general public. It does not contain warnings or cautions to advise non-technical individuals of potential dangers in attempting to service a product. Products powered by electricity should be serviced or repaired only by experienced professional technicians. Any attempt to service or repair the product or products dealt with in this service information by anyone else could result in serious injury or death.



**1. Note**

Refer to the service manual for Model No. SE-HD515MD (ORDER No. AD0003056C2) for information on Accessories and Packaging.

**2. Blue LED**

- The blue LED mounted to each sides of front panel is very sensitive to static electricity. When handling the LED base plate, be very careful about it.
- Do not replace the blue LED by itself because it may be subject to electrostatic breakdown or deterioration in quality. When replacing the LED base plate, be sure to replace L and R sides simultaneously to adjust the brightness. For configuration at the time of supply of replacement parts, refer to **Printed Circuit Board Diagram**.

**3. Before Repair**

This equipment (SJ-HD515), which is a component of the system, is supplied with power from the Amplifier (SE-HD515MD) through the Tuner (ST-HD515MD). When repairing this equipment or checking operation of the system, be sure to connect to the amplifier and tuner with it. This equipment, even in the state of it as a single equipment, permits power supply and operation check. When operating it as a single equipment without the amplifier and tuner, refer to the **To Supply Power Source and Signal Check** .

**4. Handling Precautions for MD Unit**

The laser diode in the MD unit (optical pickup) may break down due to potential difference

caused by static electricity of clothes or human body. So be careful of electrostatic breakdown during repair of the MD unit (optical pickup).

#### 4.1. Handling of MD Unit (optical pickup)

1. Do not subject the MD unit (optical pickup) to static electricity as it is extremely sensitive to electrical shock.
2. To protect the breakdown of the laser diode, an anti-static shorting pin is inserted into the flexible board (FPC board). Refer to [Fig. 4-1](#).
3. Take care not to apply excessive stress to the flexible board (FPC board).

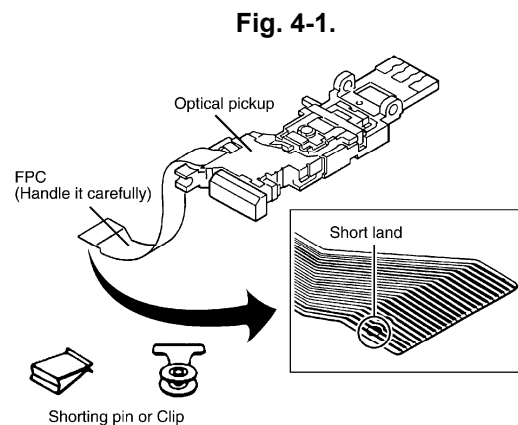

#### 4.2. Grounding for electrostatic breakdown prevention

##### 4.2.1. Human body grounding

Use the anti-static wrist strap to discharge the static electricity from your body. Refer to [Fig. 4-2](#).

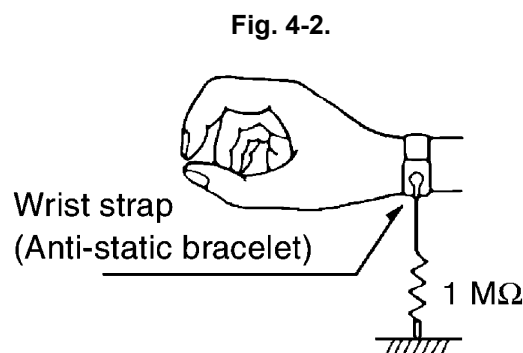

##### 4.2.2. Work table grounding

Put a conductive material (sheet) or steel sheet on the area where the MD unit (optical pickup) is placed, and ground the sheet. Refer to [Fig. 4-3](#).

Fig. 4-3.

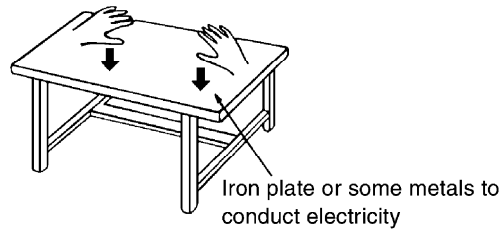

**Caution:**

The static electricity of your clothes will not be grounded through the wrist strap.

So take care not to let your clothes touch the MD unit (optical pickup).

## 5. Precaution of Laser Diode

**CAUTION:**  
THIS PRODUCT UTILIZES A LASER.  
USE OF CONTROLS OR ADJUSTMENTS OR PERFORMANCE OF PROCEDURES OTHER THAN THOSE SPECIFIED HEREIN MAY RESULT IN HAZARDOUS RADIATION EXPOSURE.

**CAUTION:** This product utilizes a laser diode with the unit turned "on", invisible laser radiation is emitted from the pickup lens.  
Wave length: 780 nm  
Maximum output radiation power from pickup: 100 µW/VDE

Laser radiation from the pick up unit is safety level, but be sure the followings:

1. Do not disassemble the pickup unit, since radiation from exposed laser diode is dangerous.
2. Do not look at the focus lens using optical instruments.
3. Recommend not to look at pickup lens for a long time.

**ACHTUNG:** Dieses produkt enthält eine laserdioden. Im eingeschalteten zustand wird unsichtbare laserstrahlung von der lasereinheit adgestrahlt.

Wellenlänge: 780 nm  
Maximale strahlungsleistung der lasereinheit: 100 µW/VDE

Die strahlung an der lasereinheit ist ungefährlich, wenn folgende punkte beachtet werden:

1. Die lasereinheit nicht zerlegen, da die strahlung an der freigelegten laserdioden gefährlich ist.
2. Nicht mit optischen instrumenten in die fokussierlinse blicken.
3. Nicht über längere zeit in die fokussierlinse blicken.

(Back of product)

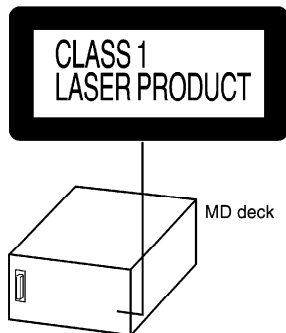

DANGER	INVISIBLE LASER RADIATION WHEN OPEN. AVOID DIRECT EXPOSURE TO BEAM.
ADVARSEL	USYNLIG LASERSTRÅLING VED ÅBNING. NÅR SIKKERHEDSÅPBRYDERE ER I DE AF FUNKTION. UNDGÅ UDSETTELSE FOR STRÅLING.
VARO!	AVATTAESSA JA SUOJALUKITUS OHITETTAESSA OLET ALTTIINA NÄKYMÄTÖNÄ LASERSÄTELYLLE. ÄLÄ KATSO SÄTEESEEN.
WARNING	OSYNLIG LASERSTRÅLING NÅR DENNA DEL ÄR ÖPPNAD OCH SPÄRREN ÄR URKOPPLAD. BETRÄKTA EJ STRÅLEN.
ADVARSEL	USYNLIG LASERSTRÅLING NÅR DEKSEL ÅPNES OG SIKKERHEDSLÅS BRYTES. UNNGÅ EKSPONERING FOR STRÅLEN.
VORSICHT	UNSICHTBARE LASERSTRALUNG, WIENN ABDECKUNG GEÖFFNET. NICHT DEM STRAHL AUSSETZEN.

(Inside of product)

(Indersiden at apparatet)

(Tuotteen sisällä)

(Apparatens insida)

(Produktets insida)

(Im Inneren des Gerätes)

## 6. Location of Controls

## 7. Operation Checks and Component Replacement / Procedures

- This section describes procedures for checking the operation of the major printed circuit boards and replacing the main

components.

- For reassembly after operation checks or replacement, reverse the respective procedures. Special reassembly procedures are described only when required.

### 7.1. Checking for the main P.C.B.

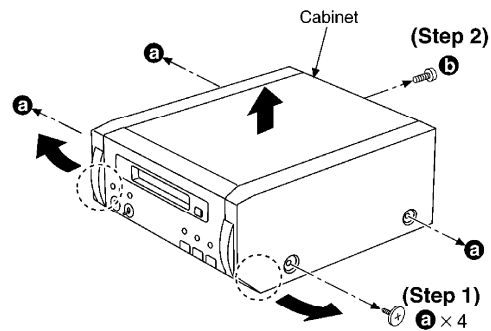

**(Step 3)**  
Spreading the both front tails indicated with (⊖) of cabinet a small amount, lift up and remove the cabinet in the direction of arrow.

- Check the main P.C.B. as shown below.

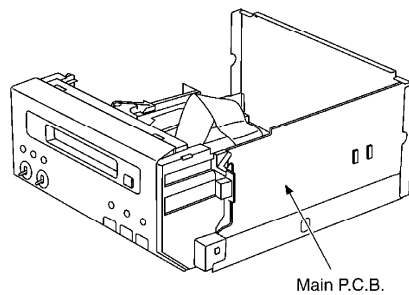

### 7.2. Checking for the MD servo P.C.B.

#### 7.2.1. Checking for the MD servo P.C.B. (A side)

- Follow the (Step 1) - (Step 3) of item 7.1.

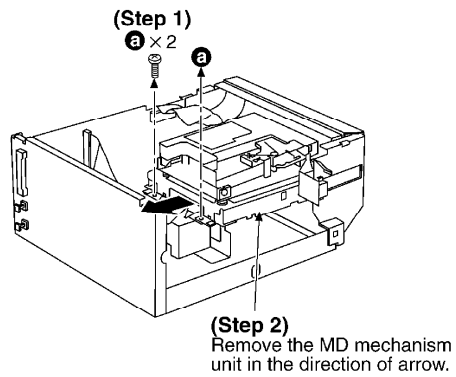

- Check the MD servo P.C.B. (A side) as shown below.

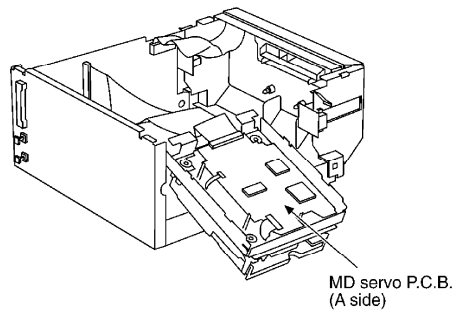

### 7.2.2. Checking for the MD servo P.C.B. (B side)

- When checking the IC1 on the of MD servo P.C.B. (B side), it can be measured with test point on the MD servo P.C.B. (A side).

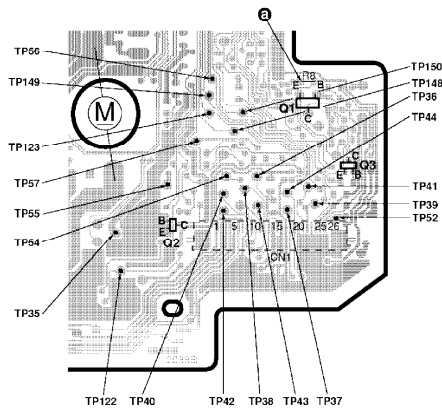
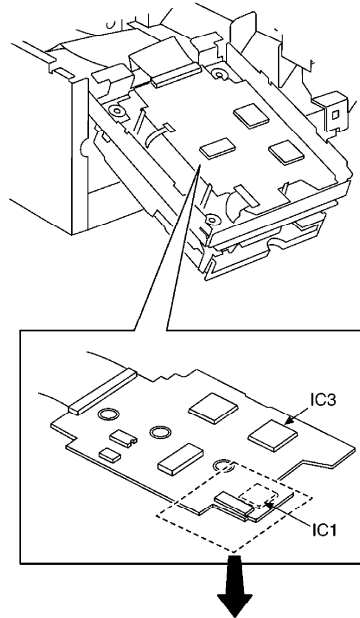

Pin No. of IC1	Test point	Pin No. of IC1	Test point
2PIN	Left side of R8 (⊕)	32PIN	TP52
5PIN	TP54	36PIN	Equivalent for pin 16 of IC3
11PIN	TP55	37PIN	TP35
16PIN	TP57	38PIN	TP44
21PIN	TP56	39PIN	TP37
26PIN	TP36	40PIN	TP38
27PIN	TP150	41PIN	TP43
28PIN	TP149	44PIN	TP42
29PIN	TP148	45PIN	TP40
30PIN	TP123	46PIN	TP39
31PIN	TP122	47PIN	TP41

(The waveforms are noted on the schematic diagram.)

### 7.3. Replacement for the magnetic head and optical pickup - Follow the (Step 1) - (Step 3) of item 7.1.

**(Step 1)**

**a** × 2

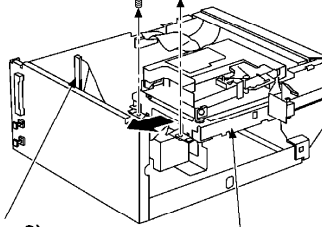

**(Step 2)**  
Pull out the FFC  
from the connector.

**(Step 3)**  
Remove the MD mechanism  
unit in the direction of arrow.

**(Step 4)**

Remove the 2 FPCs  
from the connector.

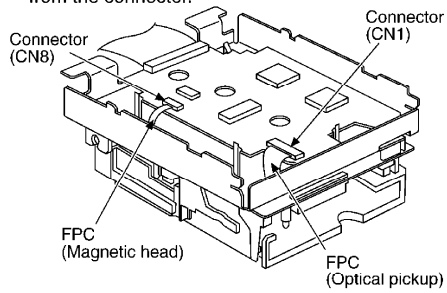

**NOTE:**  
Insert a short pin into the  
traverse  
unit FPC board.  
(Refer to "Handling Precautions  
for MD unit".)

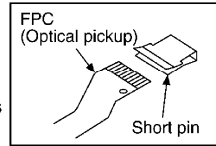

**(Step 5)**

Remove the  
pressure spring  
from latch.

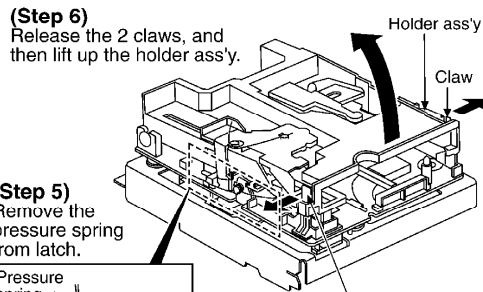
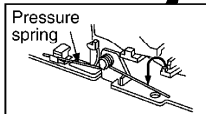

**NOTE:**  
When installing the holder ass'y,  
the pressure spring should be  
latched correctly.



**(Step 7)**

Set the holder ass'y and MD mechanism unit at a 60 degree angle, and then pull out the holder ass'y.

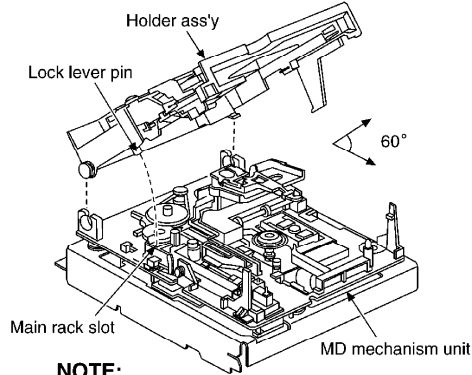

**NOTE:**

When installing the holder ass'y, align the lock lever pin with the main rack slot.

**NOTE:**

1. Take care not to damage the magnetic head.
2. Do not tighten the set screw (b) in excessive torque. (The parts may be damaged.)

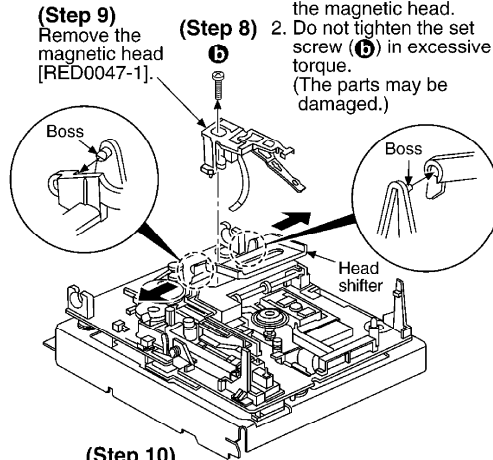

**(Step 9)**  
Remove the magnetic head [RED0047-1].

**(Step 8)**

**(Step 10)**

Spread the lugs of head shifter, and then release the lugs from boss.

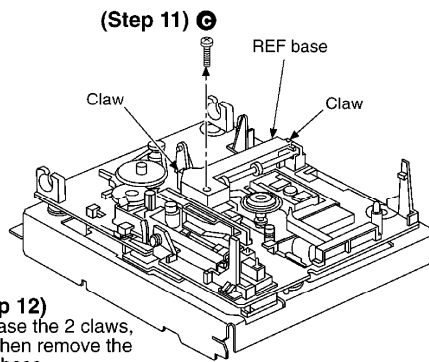

**(Step 12)**

Release the 2 claws, and then remove the REF base.

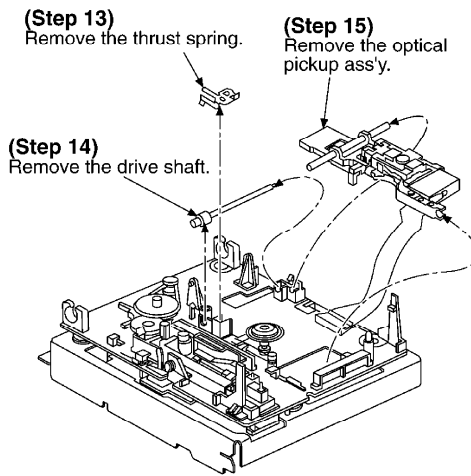

**(Step 16)**  
Pull out the main shaft.

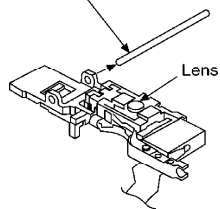

**NOTE:**

1. Use care to prevent damage the optical pickup, due to the precision construction.
2. Do not apply the grease on the lens of optical pickup.
3. Do not touch the lens of the optical pickup.

**(Step 17)**

**(Step 18)**  
Remove the nut plate spring and nut plate.

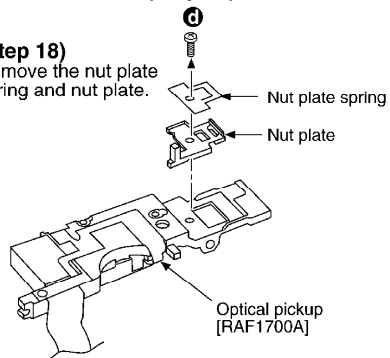

**Notice for installing the optical pickup**

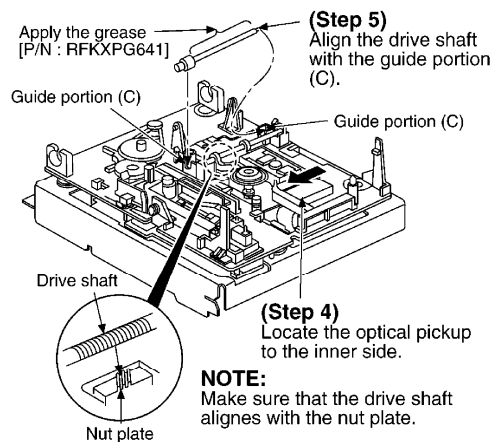
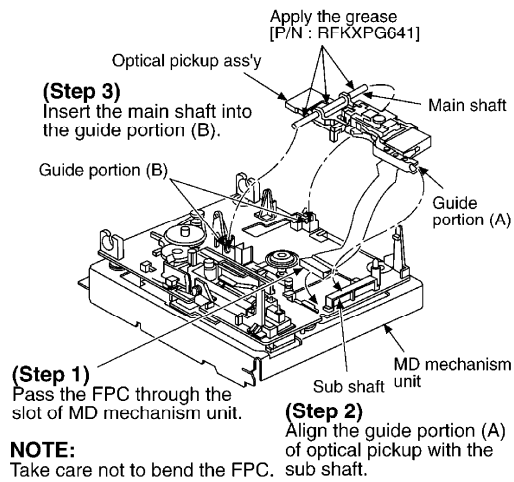

**7.4. Replacement for the belt and loading motor ass'y**  
- Follow the (Step 1) - (Step 3) of item 7.1.

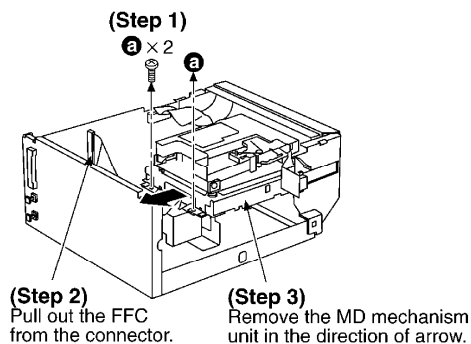

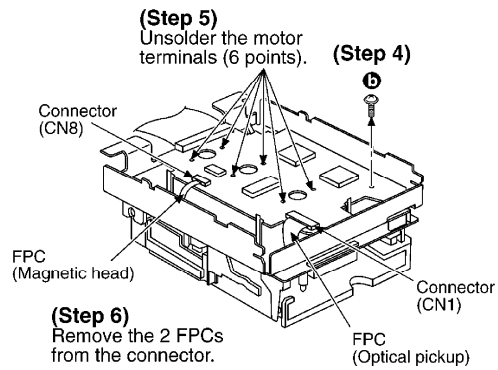

**NOTE:**  
Insert a short pin into the traverse unit FPC board.  
(Refer to "Handling Precautions for MD unit".)

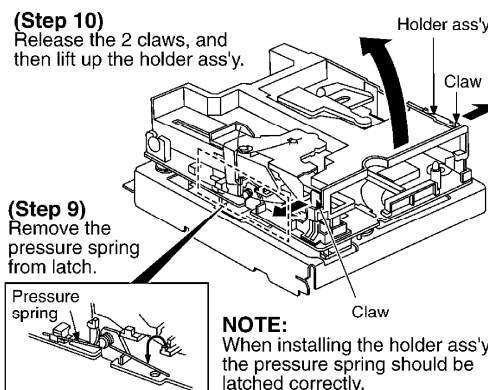
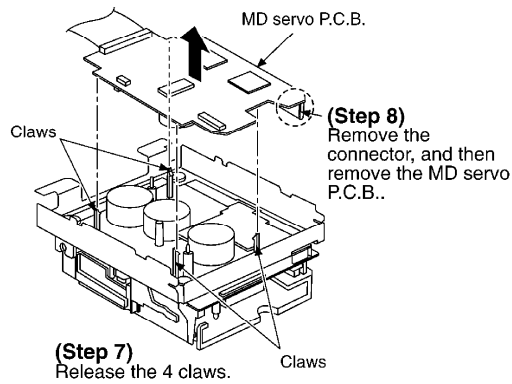
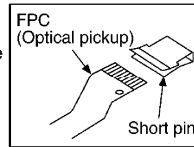

**(Step 11)**  
Set the holder ass'y and MD mechanism unit at a 60 degree angle, and then pull out the holder ass'y.

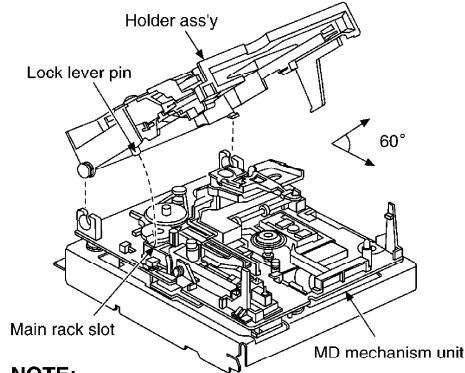

**NOTE:**  
When installing the holder ass'y, align the lock lever pin with the main rack slot.

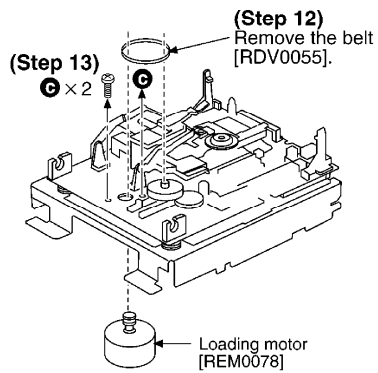

**Notice for installing the loading motor**

- Align the hole of loading motor with the boss of mechanism chassis, and then install the loading motor.

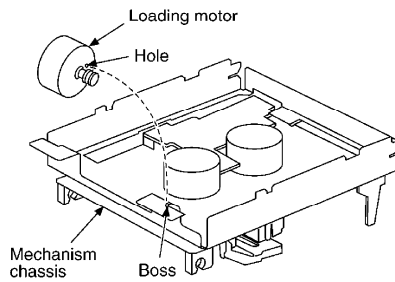

**7.5. Replacement for the traverse motor ass'y**

- Follow the (Step 1) - (Step 3) of item 7.1.
- Follow the (Step 1) - (Step 11) of item 7.3.

**(Step 2)**  
Remove the magnetic head [RED0047-1].

**(Step 1)**

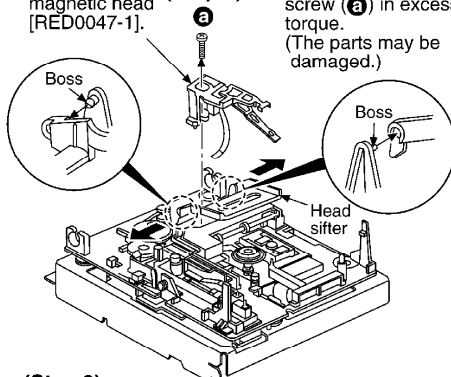

**NOTE:**

1. Take care not to damage the magnetic head.
2. Do not tighten the set screw (a) in excessive torque. (The parts may be damaged.)

**(Step 3)**  
Spread the lugs of head sifter, and then release the lugs from boss.

**(Step 4)**

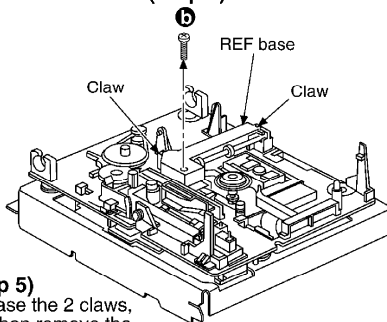

**(Step 5)**  
Release the 2 claws, and then remove the REF base.

**(Step 6)**

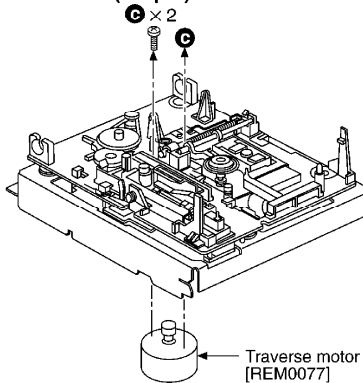

**Notice for installing the traverse motor**

- Align the hole of traverse motor with the boss of mechanism chassis, and then install the traverse motor.

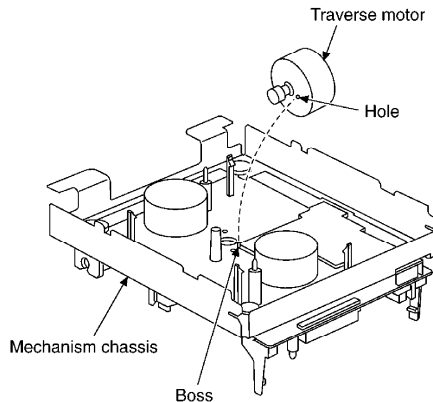

## 8. Self-Diagnostic Function

This unit is equipped with a Self-Diagnostic Function, so that if the unit operates incorrectly, the fault is displayed using an error code on the FL display of the Tuner (ST-HD515MD). The system control IC and FL display are part of the tuner so make sure the system has been connected properly before using this function. (This unit can be operated independently, although the Self-Diagnostic Function cannot be used.) Use this Self-Diagnostic Function when servicing the unit.

### 8.1. Setting to the Self-Diagnostic Function

1. Turn on the power.

2. Hold down the  button for at least 2 seconds and then

press the      button for at least 2

seconds while continuing to hold down the  button. Refer to [Fig. 8-1](#).

The unit sets to Self-Diagnostic Function. Then an error code is displayed on the FL display of the Tuner (ST-HD515MD) if any. For details of the error code, refer to [Table 8-1](#). In case of no error, “

” is displayed on the FL display of the tuner.

3. If more than one error exists, the display will sequentially show

the respective error codes each time



Fig. 8-1.

**SJ-HD515**

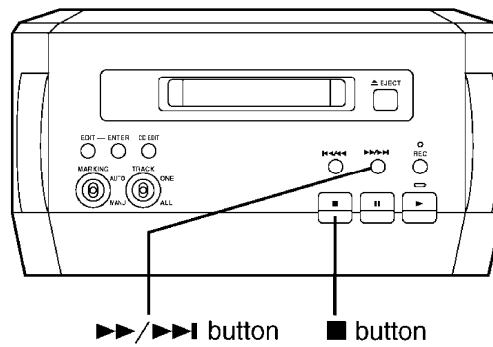

Table 8-1.

Error code	Symptom	Possible cause
F15	Interval till MD starts playing is too long.	- Traverse det. switch (S8) is defective; Check and replace if necessary.
F28	MD cannot be loaded.	- Confirm that the disc is not catching on anything. - The connection (flexible circuit board or connector cable) between the and MD servo circuit board is disconnected or damaged; check and re-necessary. - The MD unit may be malfunctioning; replace it.
F29	MD cannot be ejected.	- Confirm that the disc is not catching on anything. - The connection (flexible circuit board or connector cable) between the and MD servo circuit board is disconnected or damaged; check and re-necessary. - The MD unit may be malfunctioning; replace it.

### 8.2. Canceling the Self-Diagnostic Function

The Self-Diagnostic Function can be canceled by pressing the power button (POWER) on the Amplifier (SE-HD515MD) to turn off the system. And then pressing the power button again to turn it on again.

### 8.3. Clearing the Self-Diagnostic Function

The contents of abnormality display are stored in memory. In order to clear the memory, continue to press the STOP button for at least 2 seconds while in the Self-Diagnostic Function. The memory will clear. Always be sure to clear this memory after completing repair.

## 9. To Supply Power Source and Signal Check

**Caution:**

- It is very dangerous to look at or touch the laser beam. (Laser radiation is invisible.) With the unit turned ON, laser radiation is



emitted from the pickup lens.

- Avoid exposure to the laser beam, especially when performing adjustments.

This unit (SJ-HD515) is designed to operate on power supplied from the Amplifier (SE-HD515MD) through the Tuner (ST-HD515MD). When connecting the unit to other system components, do not connect to the Amplifier (SE-HD515MD) directly. When operating the unit (SJ-HD515) alone for testing and servicing without having power supplied from the Amplifier (SE-HD515MD), use the following method.

### 9.1. Power Supply to This Unit alone

1. Setting of the unit switches: Set MARKING to AUTO and TRACK to ONE. Refer to [Fig. 9-1](#).
2. Short the IC10-pin 67 (TP77) and GND (TP74) with the lead wire. Refer to [Fig. 9-2](#). (This enables the unit to enter the operation mode and to active the operation switches on the front panel.)
3. Apply DC 10 V between the CP304-pin 5 (+10 V) and CP304-pin 11 (GND). Refer to [Fig. 9-3](#). (The LED of REC and PLAY will light up. The PLAY LED is orange color.)

Fig. 9-1.

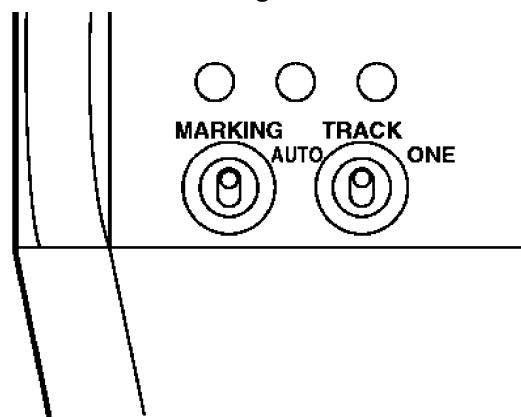
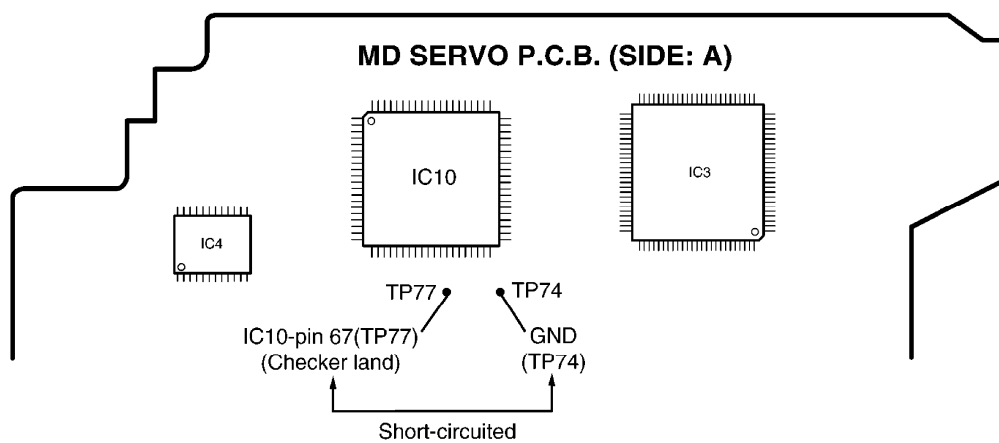
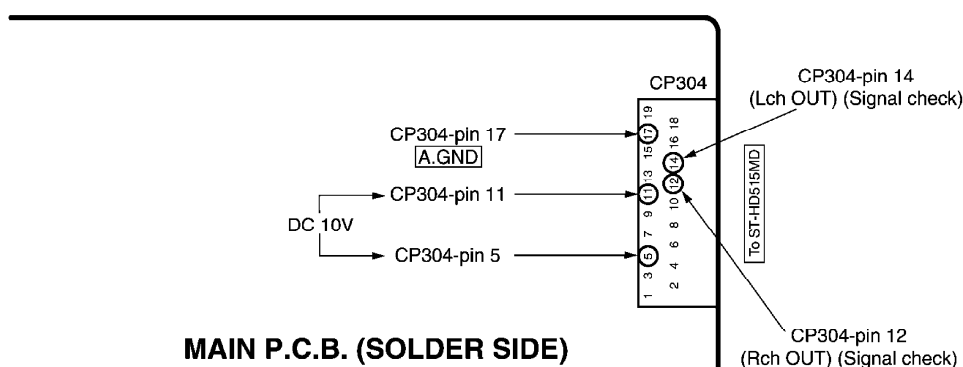

Fig. 9-2.



**Fig. 9-3.**



## 9.2. Preparation for Play/Rec Signal Check

Connect the oscilloscope or the speaker with built-in amplifier to the section between CP304-pin 12 (R ch OUT) and CP304-pin 17 (A.GND) as well as the section between CP304-pin 14 (L ch OUT) and CP304-pin 17 (A.GND) and check if the signals are outputting from this unit. Refer to [Fig. 9-3.](#)

## 9.3. Checking Play/Rec Signal to This Unit alone

### 9.3.1. Necessary Instruments

- Recorded MD
- Recordable MD
- Optical fiber cable
- Portable CD player and CD



(You can check this operation with any other player that has an optical digital output terminal but the portable CD player. The following procedure explains check operation with the portable CD player, but the procedure is the same for other players.)

### 9.3.2. Playback Signal Check

1. Set the unit so that Power Supply to This Unit alone as previously explained.

2. Prepare for Play/Rec Signal Check.

3. Set the recorded MD in the unit.

4. Press the  button and check if the MD play backs normally. (When the  button is pressed, the PLAY LED turns green.) Refer to [Fig. 9-4](#).

5. Remove the MD after check. (Continued to Recording Signal Check.)

Fig. 9-4.

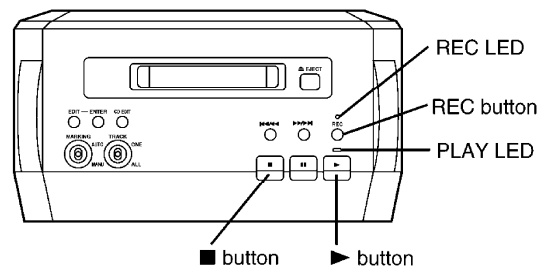

### 9.3.3. Recording Signal Check

1. After completing the item 5 of Playback Signal Check, connect to the portable CD player (or any other player with an optical digital output terminal). Refer to [Fig. 9-5](#).

2. Set the recordable MD.

3. Press the REC button. The REC LED (red color) blinks. Refer to [Fig. 9-4](#).

4. Playback the CD and press the  button. The recording starts. Refer to [Fig. 9-4](#).

5. Press the  button. (UTOC will be written.) Refer to [Fig. 9-4](#).

6. Playback the MD and check if the MD is recorded.

7. Remove the MD after check.

8. Turn off the power, and remove the lead wire between the IC10- pin 67 (TP77) and GND (TP74). (Refer to [Power Supply to This Unit alone.](#))

Fig. 9-5.

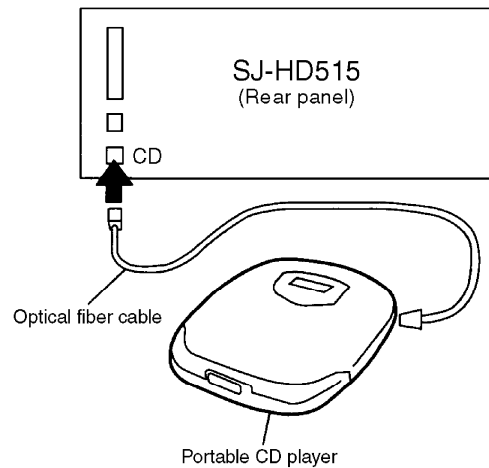

## 10. Schematic Diagram Notes

- This schematic diagram may be modified at any time with the development of new technology.

**Notes:**

**S1:**

**PROTECT det. switch**

**S2:**

**REFLECT det. switch**

**S3:**

**LOAD OPEN det. switch**

**S4:**

**DISC IN det. switch**

**S5:**

**LOAD PLAY/REC det. switch**

**S6:**

**LOAD PLAY det. switch**

**S7:**

**LOAD TRG det. switch**

**S8:**

**Traverse det. switch**

**S401:**

**Eject switch (  EJECT )**

**S402:**

**CD edit recording switch (CD EDIT)**

**S403:**

**Enter switch (ENTER)**

**S404:**

**Edit switch (EDIT)**

**S405:**

**Stop switch (  )**

**S406:**

**Pause switch (  )**

**S407:**

**Playback switch (  )**

**S408:**

**Record switch (REC)**

**S409:**

**R.Skip/search switch (  /  )**

**S410:**

**F.Skip/search switch (  /  )**

**S411:**

**Marking mode select switch in AUTO position (MARKING)**

## S412:

One track/all tracks switch in ONE position (TRACK)

## VR1:

Laser power adjustment VR

- Indicated voltage values are the standard values for the unit measured by the DC electronic circuit tester (high-impedance) with the chassis taken as standard. Therefore, there may exist some errors in the voltage values, depending on the internal impedance of the DC circuit tester.

No mark

: MD Stop

( )

: MD Play

< >

: MD Rec

- Important safety notice:

Components identified by  mark have special characteristics important for safety.

Furthermore, special parts which have purposes of fire-retardant (resistors), high-quality sound (capacitors), low-noise (resistors), etc. are used.

When replacing any of components, be sure to use only manufacturer's specified parts shown in the parts list.

- Caution!

IC and LSI are sensitive to static electricity.

Secondary trouble can be prevented by taking care during repair.

Cover the parts boxes made of plastics with aluminum foil.

Ground the soldering iron.

Put a conductive mat on the work table.

Do not touch the legs of IC or LSI with the fingers directly.

- Voltage and signal line



: Positive voltage line



: Playback signal line

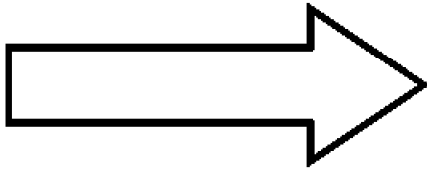

: Recording signal line

**11. Schematic Diagram**

**12. Printed Circuit Board Diagram**

**13. Type Illustration of ICs, Transistors and Diodes**

**14. Wiring Connection Diagram**

**15. Block Diagram**

**16. Troubleshooting Guide**

**17. Terminal Function of ICs**

**17.1. IC1 (AN8772FHQ): RF Amp**

Pin No.	Terminal Name	I/O	Function
1	CENVD	I	D signal detection input
2	LDO	O	LD amp output terminal
3	APC PD	I	Photo diode detection input
4	LD IN	I	LD amp input
5	APC REF	I	APC amp reference voltage input
6	TEMP IN	I	Temperature sensor amp input
7	TEMP	O	Temperature sensor amp output
8	ADIP	O	ADIP FM signal output
9	TOFS	I	Tracking error off-set adjustment input
10	TBAL	I	Tracking balance adjustment signal input
11	TE	O	Tracking error signal output
12	CRS IN	I	Track cross signal input
13	TGAIN	I	TE gain adjustment input
14	LNP	O	Lens position signal output
15	AB GAIN	I	APP signal gain adjustment input
16	FE	O	Focus error signal output
17	AS GAIN	I	AS gain adjustment input
18	FBAL	I	Focus balance adjustment input
19	AS/MON3T	O	AS signal output
20	CEA	I	3T envelope detection input
21	BDO/TRCRS	O	BDO/Track cross signal output
22	CBD O	O	BDO detection capacitor terminal
23	OFT O	O	Off-track detection signal output
24	GND	-	GND terminal
25	OFT IN	I	Off-track detection signal input
26	Vcc	I	Power supply terminal
27	NRFDET / OFTR	O	RF detect signal output/Off-track signal output
28	NRFLD	I	Serial command latch signal input
29	RF DATA	I	Serial command data signal input
30	RFCK	I	Serial command clock signal input
31	NRFSTBY	I	Standby control signal input
32	OUT RF	O	EFM signal output



Pin No.	Terminal Name	I/O	Function
33	CRF AGC	-	RFAGC capacitor connect terminal
34	EQ IN	I	EQ input
35	ARFO	O	RF amp output
36	SVREF	I	Reference signal input
37	VREF	O	Reference voltage output
38	RF1	I	RF 1 signal input
39	RF2	I	RF 2 signal input
40	F1	I	F 1 signal input
41	F2	I	F 2 signal input
42	CLPF1	I	APP correction CPF capacitor connect terminal
43	CLPF1	I	RF equalizer adjustment resistor connect terminal
44	A	I	Main beam A signal input
45	B	I	Main beam B signal input
46	C	I	Main beam C signal input
47	D	I	Main beam D signal input
48	CENVC	I	C signal detection input

## 17.2. IC2 (AN8814SB-E1): / Focus/Tracking Coil, / Spindle/Traverse Motor Drive

Pin No.	Terminal Name	I/O	Function
1	REG B	-	3.3 V external transistor control (Not used, open)
2	REG M	-	3.3 V regular output monitor (Not used, connected to GND)
3	NC	-	Not used, open
4	OPO	O	Op-amp output
5	OP-	I	Op-amp invert input
6	OP+	-	Op-amp non-invert output (Not used, connected to GND)
7	Vcc	I	Power supply terminal
8	1/2PVcc 2	O	1/2PVcc output terminal 2 (Connected to GND via capacitor)
9	PVcc2	I	Power supply terminal for driver
10	PGND2	-	GND terminal
11	VO4-	O	Tracking coil drive output
12	VO4+	O	Tracking coil drive output
13	VO3-	O	Focus coil drive output

Pin No.	Terminal Name	I/O	Function
14	VO3+	O	Focus coil drive output
15	VO2-	O	Traverse motor drive output
16	VO2+	O	Traverse motor drive output
17	VO1-	O	Spindle motor drive output
18	VO1+	O	Spindle motor drive output
19	PGND1	-	GND terminal
20	PVcc1	I	Power supply terminal
21	1/2PVcc 1	O	1/2PVcc output terminal 1 (Connected to GND via capacitor)
22	VREF	I	Reference voltage input
23	IN1	I	Spindle motor drive signal input
24	PC1	I	Power cut 1 input
25	IN2	I	Traverse motor drive signal input
26	PC2	I	Power cut 2 input
27	IN3	I	Focus drive signal input
26	IN4	I	Tracking drive signal input

### 17.3. IC3 (MN66616RA4): / ATRAC Encoder/Decoder, Servo Signal Processor

Pin No.	Terminal Name	I/O	Function
1	ADIP	I	ADIP FM signal input
2	LNP	I	Lens position signal input
3	FE	I	Focus error signal input
4	TE	I	Tracking error signal input
5	AS	I	AS signal input
6	DRMONI	I	Drive voltage monitor input
7	BAT	I	Battery power supply terminal
8	AMONI	-	Servo analog monitor signal output (Not used, open)
9	VREFI	I	Reference voltage input
10	TOFS	O	Tracking error off-set adjustment output
11	FBAL	O	Focus balance adjustment output
12	TBAL	O	Tracking balance adjustment output
13	TGAIN	O	TE error gain adjustment output

Pin No.	Terminal Name	I/O	Function
14	ASGAIN	O	Main beam amp gain adjustment output
15	ABGAIN	O	APP adjustment output
16	AVDD1	I	Power supply terminal
17	AVss1	-	GND terminal
18	FOD	O	Focus drive signal output
19	TRD	O	Tracking drive signal output
20	TVD	O	Traverse motor drive signal output
21	SPD	O	Spindle motor drive signal output
22	SPON	O	Drive IC spindle ON signal output
23	TVON	O	Drive IC traverse ON signal output
24	DVDD0	I	Power supply terminal
25	FG	I	FG input
26	NRECT	O	Rec/Play switching signal output
27	IVDD2	I	Power supply terminal for I/O pad
28	IVDD0	-	Power supply terminal for I/O pad
29	DVss0	-	GND terminal
30   32	RAD12   RAD10	-	DRAM address output (Not used, open)
33   42	RAD9   RAD0	O	DRAM address output
43   46	RDT3   RDT0	I/O	DRAM data input/output
47	NRAS	O	DRAM row address strobe signal output
48	NCAS	O	DRAM column address strobe signal output
49	NWE	O	DRAM write enable signal output
50	NRST	I	Reset signal input
51	SELAD	I	MSP/MDA, I/F address select signal input
52	SSCK	I	MSP/MDA, I/F clock signal input

Pin No.	Terminal Name	I/O	Function
53	SSDW	I	MSP/MDA, I/F write data input
54	SSDR	O	MSP/MDA, I/F read data output
55	MDISY	O	Leader synchronous signal output
56	SCTSY	O	ADIP synchronous noise output
57	SGSYNC	O	Frame synchronous signal output
58	DVDD1	I	Power supply terminal
59	IVDD1	I	Power supply terminal for I/O pad
60	DVss1	-	GND terminal
61	FS384	O	384 Fs output
62	SCL	O	Bit clock signal output
63	SWS	O	Word clock signal output
64	SDAP	O	Audio data signal output
65	SDAR	I	Audio data signal input
66	LRCK	I	CD word clock signal input
67	BCK	I	CD bit clock signal input
68	DATA	I	CD data signal input
69	TX	-	Digital audio interface signal output (Not used, open)
70	RX1	I	Digital audio interface signal 1 input
71	RX2	I	Digital audio interface signal 2 input
72	NREFM	-	EFM modulation inverted output (Not used, open)
73	REFM	O	EFM modulation signal output
74	MONI3	-	Monitor signal output (Not used, open)
75	MONI2	-	Monitor signal output (Not used, open)
76	MONI1	-	Monitor signal output (Not used, open)
77	MONI0	-	Monitor signal output (Not used, open)
78	TS3	-	Reserved (Not used, connected to GND)
79	TS2	-	Reserved (Not used, connected to GND)
80	TS1	-	Reserved (Not used, connected to GND)

Pin No.	Terminal Name	I/O	Function
81	TS0	-	Reserved (Not used, connected to GND)
82	EXSYSCK	-	External system clock input (Not used, connected to GND)
83	DVDD2	I	Power supply terminal
84	XI	I	Crystal oscillator (f=16.9344 MHz)
85	XO	O	
86	VDss2	-	GND terminal
87	RFDAT	O	RF serial data output
88	RFCK	O	RF serial clock output
89	NRFLD	O	RF serial load output
90	TRCRS	I	Track cross signal input
91	OFTR	I	Off-track signal input
92	APCD	O	Laser power PWM output
93	EXEFMCK	I	External FM clock input (Connected to GND via resistor)
94	PEFM1	O	EFM loop filter output
95	EEMIREF	I	EFM PLL reference current input
96	EEMPLLF	O	EFM signal output
97	PEFMS	I	EFM signal input
98	AVDD0	I	Power supply terminal
99	AVss0	-	GND terminal
100	TEFSEL	-	Not used, open

#### 17.4. IC10 (MN101D03DAA1): / System Control

Pin No.	Terminal Name	I/O	Function
1	DAC RST	O	DAC reset signal output (L: reset)
2	DEO	O	DE emphasis signal output (L: DE emphasis)
3	MUTE	-	Muting signal output (Not used, open)
4	AD RST	O	AD reset signal output (L: reset)
5	NRF STBY	O	RF amp standby control signal output
6	PC	O	Power supply control output
7	MSP RST	O	Reset signal output
8	LOAD1	O	Loading motor drive 1 output
9	LOAD0	O	Loading motor drive 0 output
10	NEFMON	O	Magnetic head current output
11	TEST01	-	Test terminal (Not used, open)
12	TV SW	I	Rest detect switch signal input
13	DISC IN	I	Disc in detect switch signal input
14	REFLECT	I	Reflect detect switch signal input
15	LOADSW0 / (OPEN)	I	Load OPEN detect switch signal input
16	LOADSW1 / (TRG)	I	Load TRG detect switch signal input
17	LOADSW2( / PLAY/ REC)	I	Load PLAY/REC detect switch signal input
18	LOADSW3 / (PLAY)	I	Load PLAY detect switch signal input
19	PROTECT	I	Write protect tab detect switch signal input
20	MMOD	-	Not used, connected to GND
21	RST	I	Reset signal input
22	UNITTEST	-	Test signal input (Not used, open)
23	CS2	-	Test signal input (Not used, open)
24	SCTSY	I	ADIP synchronous noise input
25	MDISY	I	Header synchronous noise input
26	PANEL / REQ	I	Panel I/F request signal input

	/ REQ		
Pin No.	Terminal Name	I/O	Function
27	LED OUT1	O	Drive signal output for LED drive (H: ON)
28	LED OUT2		
29	LED OUT3		
30	TEST02	-	Test terminal (Not used, open)
31	V <sub>DD</sub> 2(3V)	I	Power supply terminal
32	OSC1	I	Crystal oscillator (f=10.02 MHz)
33	OSC2	O	
34	V <sub>SS</sub>	-	GND terminal
35	XI	-	Not used, connected to GND
36	XO	-	Not used, open
37	V <sub>SS</sub>	-	GND terminal
38	TEST03	-	Test terminal (Not used, open)
39	EEPCS	-	EEPROM chip select signal output (Not used, open)
40	EEPCK	-	EEPROM clock signal output (Not used, open)
41	EEPDATA	-	EEPROM data signal input/output (Not used, connected to GND via resistor)
42	TEST04	-	Test terminal (Not used, open)
43	TEST05	-	Test terminal (Not used, open)
44	CF SYNC	I	MDA synchronous signal input
45	TEST06	-	Test terminal (Not used, open)
46	TEST07	I	Connected to rec/play switch signal
47	TOK OK	-	Test terminal (Not used, open)
48	HF ON	O	HF module ON signal output
49	PANEL CLK	I	PANEL I/F clock signal input
50	PANEL DATA I	I	PANEL I/F data signal input
51	PANEL DATA O	O	PANEL I/F data signal output
52	PANEL CS	O	PANEL I/F chip select signal output

Pin No.	Terminal Name	I/O	Function
53	SELAD	O	MSP/MDA, I/F address select output (H: address)
54	SS CLK	O	MSP/MDA, I/F clock output
55	SS DR	I	MSP/MDA, I/F read data input
56	SS DW	O	MSP/MDA, I/F write data output
57	LCD CK	-	LCD clock test signal output (Connected to power supply via resistor)
58	ADRS / TEST RXD	-	Test terminal (Connected to power supply via resistor)
59	LCD DATA / TXD	-	Test terminal (Not used, open)
60	VREF-	-	Connected to GND
61	TEMP	I	Temperature sensor input
62	KEY1	I	Operation key signal input
63	KEY2	I	Operation key signal input
64	MO LOAD	-	Test signal input (Not used, open)
65	SRV TEST	-	Test signal input (Not used, open)
66	LOAD P	-	Test signal input (Not used, open)
67	TEST KEY / IN	-	Test signal input (Not used, open)
68	SRV LOAD	-	Test signal input (Not used, open)
69	Vcc3V	I	Power supply terminal
70	Vcc5V	I	Power supply terminal
71	SEL ADDA	-	AD/DA converter select signal input (Not used, open)
72	SLOCK	-	Spindle lock output (Not used, open)
73	TLOCK	-	Tracking lock output (Not used, open)
74	FLOCK	-	Focus lock test signal output (Not used, open)
75	ERROR	-	Servo error test signal output (Not used, open)
76	BUSY	-	Servo busy test signal output (Not used, open)



Pin No.	Terminal Name	I/O	Function
77	SBP / RETRY	-	Spindle management retry test signal output (Not used, open)
78	SRV / RETRY	-	Servo retry test signal output (Not used, open)
79	ARDSKIP	-	Address skip test signal output (Not used, open)
80	SPMWE	-	SPM test signal output (Not used, open)

## 17.5. IC72 (M51V4400D7FS): / 4M DRAM

Pin No.	Terminal Name	I/O	Function
1	DO1	I/O	DRAM data 1 input/output
2	DO2	I/O	DRAM data 2 input/output
3	WE	I	DRAM write enable input
4	RAS	I	DRAM row address strobe input
5	A9	I	DRAM address 9 input
9	A0	I	DRAM address 0 input
10   12	A1   A3	I	DRAM address 1 - 3 input
13	Vcc	I	Power supply terminal
14   18	A4   A8	I	DRAM address 4 - 8 input
22	OE	-	DRAM output enable input (Not used, connected to GND)
23	CAS	I	DRAM column address strobe input
24	DO3	I/O	DRAM data 3 input/output
25	DO4	I/O	DRAM data 4 input/output
26	Vss	-	GND terminal

## 18. Measurements and Adjustments

### Note:

Because this unit uses the optical magnetic recording, the unit outputs over 10 times more laser than a CD player does. In adjustment mode, the laser is always being output. Therefore, be

especially careful not to look laser beam directly or to touch the laser beam when adjusting the unit and checking its operation.

## 18.1. Laser Power Adjustment

Adjust each laser power: read power for reading (play) and write power for writing (record).

### 18.1.1. Necessary Instruments

- Laser power meter (LE8010)
- Test disc (Pre-mastered disc RFKV0006 or RFKV0014)
- Recordable disc available on sales route (with music recorded)
- Insulated driver for adjustment such as a ceramic driver

### 18.1.2. Set the Unit to the Adjustment Mode

Perform the (Step 1) and (Step 2) in the item 7.2. [Checking for the MD servo P.C.B.](#) in Operation Checks and Component Replacement Procedures.

**Caution:**

#### 1. About handling the MD unit

- The magnetic head is precision unit and is very fragile. Do not deform it.
- Laser diode in the optical pickup may be destroyed by the static electricity generated in your clothes or body. Be especially careful with the static electricity.
- The optical pickup is structured extremely precisely. Do not subject to the strong impact or shock. Do not touch the lens.

#### 2. About handling the magnetic head

When replacing the magnetic head, do not tighten the mounting screw (RHD17022) too firmly. If the screw is tightened too much to deform the resin, the position of the head is moved, and this affects its recording operation.

Recommended torque for mounting screw: /  $700 \pm 100$  g cm

**Reference:**

This is the same force as using a screwdriver with a 15-mm diameter grip, you fasten the screw naturally with your thumb and index finger.

#### 3. About the driver for adjusting laser power

Use only insulated driver such as a ceramic driver. With the metal driver, it is not possible to adjust properly because of induction noise. Also, if it short-circuits with the chassis, it may destroy or

damage the laser diode.

Recommended driver: VESSEL 9000 1.8-30 / (Ceramic driver)

**Caution on optical pickup:**

- The optical pickup and the magnetic head are structured precisely; therefore, they are very fragile. Be careful not to touch them with the edge of laser power meter.
- The sensor of the laser power meter is a very fine part. Be careful not to touch it to the optical pickup lens.
- The focus point of the laser reaches to 180°C. Therefore, avoid using laser power for a long time because the sensor of the laser power meter may be burned.
- Do not allow the write power to even momentarily reach or exceed 5.5 mW. Doing so will result in damage to the optical pickup.
- Do not set the unit to the laser power adjustment mode with the MD loaded. Doing so may result in damage to the MD.

**18.1.3. Adjustment Procedure**

1. Remove the MD unit from the system unit.
2. Short-circuit the IC10-pin 67 (TP77) and GND (TP74) with the lead wire. (This enables the unit to enter the operation mode and to active the operation switches on the front panel.)
3. Set the MD unit in the system unit and turn on the power. The LED of REC and PLAY will light up.
4. Slide the sensor cover of the laser power meter. / Refer to **Fig. 18-1.**

Fig. 18-1.

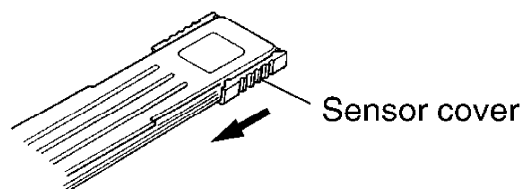

5. Position the sensor of the laser power meter directly above the optical pickup. Refer to **Fig. 18-2.**

Fig. 18-2.

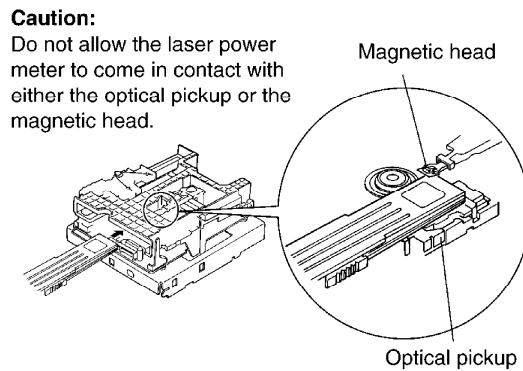

6. Press the CD EDIT button and confirm that the reading of the laser power meter is within the specified range. If it is not within the specified range, adjust by turning VR1. Refer to **Fig. 18-3**.

Fig. 18-3.

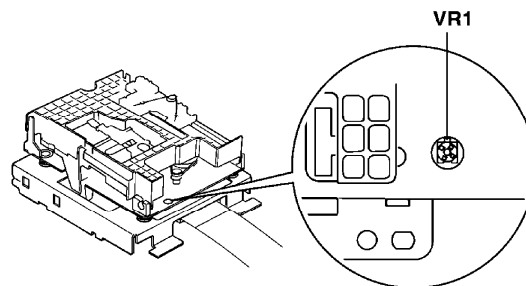

**Specified range (read power): 600  $\mu$  W or lower**

**Caution:**

Proceeding on to the subsequent adjustment procedure with the read power exceeding 600  $\mu$  W will result in damage to the optical pickup.

7. Press the CD EDIT button and read the write power.  
Specified range (write power): 4.8 mW $\pm$ 0.1 mW
8. If it is not within 4.8 mW $\pm$ 0.1 mW, adjust by turning VR1. Refer to **Fig. 18-3**.

**Caution:**

Do not allow the write power to even momentarily reach or exceed 5.5 mW. Doing so will result in damage to the optical pickup.

9. Press the CD EDIT button, the read power will be displayed again.  
/ Confirm that the read power is within 540  $\mu$  W ~ 660  $\mu$  W.
10. Then, again press the CD EDIT button. The laser power recorded in the laser ROM will be displayed.  
Confirm that it is within 540  $\mu$  W ~ 660  $\mu$  W.

11. Press the STOP button and exit the adjustment mode.
12. Turn off the power and remove the lead wire between the IC10-pin 67 (TP77) and GND (TP74). This ends the adjustment mode.

## 19. Replacement Parts List

### Notes:

**- Important safety notice:**

Components identified by  mark have special characteristics important for safety.

Furthermore, special parts which have purposes of fire-retardant (resistors), high-quality sound (capacitors), low-noise (resistors), etc. are used.

When replacing any of components, be sure to use only manufacture's specified parts shown in the parts list.

- The marking [RTL] indicates that Retention Time is Limited for this item. After the discontinuation of this assembly in production, the item will continue to be available for a specific period of time. The retention period of availability is dependent on the type of assembly, and in accordance with the laws governing part and product retention. After the end of this period, the assembly will no longer be available.**
- All parts are supplied by MESA.**

Ref. No.	Part No.	Part Name & Description	Pcs	Remarks
1	RHD30007-S	SCREW	4	
2	RKM0364-2S1	CABINET	1	
3	RYQ0274-S	SIDE PANEL UNIT(L)	1	
3-1	XTBS26+8J	SCREW	1	
4	RKA0114-K	FOOT	4	
4-1	RKA0083-K	CUSHION	4	
5	RGG0148B-S	FRONT PANEL	1	
6	RYQ0275-S	SIDE PANEL UNIT(R)	1	
6-1	XTBS26+8J	SCREW	1	
7	REP2683F-S	LED PCB	1	
8	XTBS3+10JFZ1	SCREW	1	
9	RGK0977-2S	MD LID	1	
10	RGL0386-Q	LENS1	1	
11	RGL0387-Q	LENS2	1	
12	RGP0642-1S	SUB PANEL	1	
13	RGU1599A-1S	BUTTON,OPERATION	1	
14	RHD20010	SCREW	1	
15	RMB0514	SPRING	1	
16	XTBS26+8J	SCREW	4	
17	XTBS3+8JFZ1	SCREW	12	
18	XTB3+5JFZ	SCREW	4	
19	REZ1048	FFC(30P)	1	
100	RED0047-1	MAGNETIC HEAD	1	
101	RHD17021	SCREW	1	
102	RHD17022	SCREW	1	
103	RMC0348	SPRING	1	
104	RMC0349	NUT PLATE SPRING	1	
105	RML0515	HEAD SIFTER	1	
106	RMQ0750	REF BASE	1	
107	RMQ0751	NUT PLATE	1	
108	RMS0611	MAIN SHAFT	1	
109	RXJ0021	DRIVE SHAFT	1	
110	RXK0249	MECHANISM CHASSIS	1	
110-1	RDV0055	BELT	1	
110-2	REM0077	TRAVERSE MOTOR	1	
110-3	REM0078	LOADING MOTOR	1	
110-4	RMB0548	SPRING	1	
110-5	RMQ0752	DETECTOR PIN 1	1	
110-6	RMQ0753	DETECTOR PIN 2	2	
110-7	XQN17+C25FZ	SCREW	4	
110-8	XYC2+FF105	SCREW	1	
111	RAF1700A	OPTICAL PICK-UP	1	
112	XTW2+6S	SCREW	1	
113	RHD20053	SCREW	4	
114	RMB0504	SPRING	4	
115	RMG0447-K	DUMPER	4	
116	XTN17+6GFZ	SCREW	1	
117	RXQ0558	HOLDER	1	
C1	ECUV1H221KBV	50V 220U	1	
C4	ECUVNA105ZFV	10V 1U	1	
C5	ECUVNA224KBV	10V 0.22U	1	
C6	ECUVNA105ZFV	10V 1U	1	

Ref. No.	Part No.	Part Name & Description	Pcs	Remarks
C7,C8	ECUVNA224KBV	10V 0.22U	2	
C11	ECUVNE223KBV	25V 0.022U	1	
C12	ECUV0J474KBV	6.3V 0.47U	1	
C13	ECUV1C393KBV	16V 0.039U	1	
C14	ECUV1H102KBV	50V 1000P	1	
C15	ECST0GY106RR	4V 10U	1	
C16	ECUV1H181KV	50V 180P	1	
C17	ECUV1H332KBV	50V 3300P	1	
C18	ECUV1H562KBV	50V 5600P	1	
C19	ECUVNC104ZV	16V 0.1U	1	
C20	ECST0GY106RR	4V 10U	1	
C21	ECUV1H822KBV	50V 8200P	1	
C22	ECUV1H102KBV	50V 1000P	1	
C23	ECUVNC104ZV	16V 0.1U	1	
C24	ECUV1H102KBV	50V 1000P	1	
C25	ECUV1C393KBV	16V 0.039U	1	
C26	ECUV1H472KBV	16V 4700P	1	
C28	ECST0GY226RR	4V 22U	1	
C29	ECUV1H332KBV	50V 3300P	1	
C30	ECUV1E123KBV	25V 0.012U	1	
C31,32	ECUV1H102KBV	50V 1000P	2	
C33	ECST0GY106RR	4V 10U	1	
C34,35	ECUV1H102KBV	50V 1000P	2	
C37	ECUV1H181KV	50V 180P	1	
C40	ECUVNC104ZV	16V 0.1U	1	
C41	ECEV0JA331P	6.3V 330U	1	
C42	ECST0GY106RR	4V 10U	1	
C45	ECST0GY106RR	4V 10U	1	
C46	ECUVNC104ZV	16V 0.1U	1	
C47	ECUVNA105ZV	10V 1U	1	
C48	ECUVNC104ZV	16V 0.1U	1	
C50	ECUVNC104ZV	16V 0.1U	1	
C51,52	ECUVNA105ZV	10V 1U	2	
C53	ECUV1H332KBV	50V 3300P	1	
C55-58	ECUV1H102KBV	50V 1000P	4	
C59	ECUV1C823KBV	16V 0.082U	1	
C60	ECEV1CA100NR	16V 10U	1	
C61	ECUV0J334KBV	16V 0.33U	1	
C62	ECUV1H221KBV	50V 220P	1	
C64	ECUVNE153KBV	25V 0.015U	1	
C65	ECUVNC104KBV	16V 0.1U	1	
C66	ECUV1C823KBV	16V 0.082U	1	
C67	ECUV1H392KBV	50V 3900P	1	
C70	ECUV1E123KBV	25V 0.012U	1	
C71-76	ECUVNC104ZV	16V 0.1U	6	
C79,80	ECUVNC104ZV	16V 0.1U	2	
C81	ECUV1H560JCV	50V 56P	1	
C82	ECUVNC473KBV	16V 0.047U	1	
C83,84	ECUVNC104ZV	16V 0.1U	2	
C85	ECST0GY106RR	4V 10U	1	
C86	ECUVNE153KBV	25V 0.015U	1	
C87	ECUVNC104ZV	16V 0.1U	1	
C88,89	ECUV1H331KBV	50V 330P	2	
C90,91	ECUV1H080DCV	50V 8P	2	

Ref. No.	Part No.	Part Name & Description	Pcs	Remarks
C92,93	ECUVNC104ZFV	16V 0.1U	2	
C94	ECST0GY475RR	4V 4.7U	1	
C95	ECUVNC104ZFV	16V 0.1U	1	
C96,97	ECST0GY475RR	4V 4.7U	2	
C98	ECUVNC104ZFV	16V 0.1U	1	
C99	ECUV1H102KBV	50V 1000P	1	
C100	ECUVNC104ZFV	16V 0.1U	1	
C101	ECST0GY106RR	4V 10U	1	
C102	ECUVNC104ZFV	16V 0.1U	1	
C103	ECST0GY106RR	4V 10U	1	
C106	ECUV1H102KBV	50V 1000P	1	
C110	ECUVNC104ZFV	16V 0.1U	1	
C111	ECST0GY106RR	4V 10U	1	
C112	ECEV1CA100NR	16V 10U	1	
C113	ECUVNC104ZFV	16V 0.1U	1	
C114,15	ECUV1H561KBV	50V 560P	2	
C117	ECEV0JA331P	6.3V 330U	1	
C118	ECUVNA105KBN	10V 1U	1	
C119	ECUV1H102KBV	50V 1000P	1	
C120	ECUV1H560JCV	50V 56P	1	
C121	ECUV1H102KBV	50V 1000P	1	
C122	ECUVNA105ZFV	10V 1U	1	
C123	ECUVNC104ZFV	16V 0.1U	1	
C128	ECUVNC104ZFV	16V 0.1U	1	
C129	ECUV1H101JCV	50V 100P	1	
C133	ECUVNA105ZFV	10V 1U	1	
C134	ECUV1H331KBV	50V 330P	1	
C138	ECEV0JA470SR	6.3V 47U	1	
C139-42	ECUVNC104ZFV	16V 0.1U	4	
C143	ECST0GY106RR	4V 10U	1	
C144	ECUVNH103KBV	50V 0.01U	1	
C147-49	ECUVNH103KBV	50V 0.01U	3	
C154,55	ECUV1H330GCV	50V 33P	2	
C311,12	RCE1CKA470BG	16V 47U	2	
C314,15	ECUV1H222KBN	50V 2200P	2	
C317	ECUVNE104ZFN	25V 0.1U	1	
C318	ECEA0JKS101	6.3V 100U	1	
C319	ECUVNE104ZFN	25V 0.1U	1	
C320	ECEA0JKS101	6.3V 100U	1	
C321	ECUVNE104ZFN	25V 0.1U	1	
C322	ECEA0JKS101	6.3V 100U	1	
C323,24	ECUVNE104ZFN	25V 0.1U	2	
C325	ECA1CM222	16V 2200U	1	
C327-29	ECUVNE104ZFN	25V 0.1U	3	
C331	ECUVNE104ZFN	25V 0.1U	1	
C351,52	ECEA1CKS220	16V 22U	2	
C353	ECUVNE104ZFN	25V 0.1U	1	
C355	ECEA1AKS221	6.3V 220U	1	
C356	ECUV1H101JCN	50V 100P	1	
C357,58	ECUVNE104ZFN	25V 0.1U	2	
C361-64	ECUVNE104ZFN	25V 0.1U	4	
C365	ECUVNC105ZFN	16V 1U	1	
C366	ECEA0JKS101	6.3V 100U	1	
C401,02	ECUV1H103KBN	50V 0.01U	2	



Ref. No.	Part No.	Part Name & Description	Pcs	Remarks
CN1	RJS2A4526T	CONNECTOR(26P)	1	
CN4	RJS2A4830T	CONNECTOR(30P)	1	
CN6	RJU113W10M	CONNECTOR(10P)	1	
CN8	RJS2A4506T	CONNECTOR(6P)	1	
CP6	RJT113W10M	CONNECTOR(10P)	1	
CP302	RJS10T6ZA	CONNECTOR(10P)	1	
CP303	RJS2A3330	CONNECTOR(30P)	1	
CP304	RJT065A19	SYSTEM CONNECTOR(19P)	1	
D5,D6	SC80209TE12R	DIODE	2	
D9	MA728TX	DIODE	1	
D301	MA4033M	DIODE	1	
D302,03	MA719TA	DIODE	2	
D401	SML79420C	LED	1	
D402	LNJ201LPQJA	LED	1	
IC1	AN8772FHQ	IC	1	
IC2	AN8814SB-E1	IC	1	
IC3	MN66616RA4	IC	1	
IC4	AK4518VF-E2	IC	1	
IC5	RN5RG33AA-TL	IC	1	☠
IC6	TC7W04FTE12L	IC	1	
IC9	RN5RZ26BA-TR	IC	1	☠
IC10	MN101D03DAA1	IC	1	
IC11	TC74HCT00AFL	IC	1	
IC72	M51V4400D7FS	IC	1	
IC92	LB1830MS-TLM	IC	1	
IC301	PST597ENR	IC	1	
IC303	TC74HCT7007A	IC	1	
IC304	M5M34051FPE1	IC	1	
IC306	BA17805T	IC	1	☠
IC307	BA178M05T	IC	1	☠
IC308	BA17805T	IC	1	☠
IC309	S81233SGY-Z	IC	1	☠
ICP301	SRUN20T	IC PROTECTOR	1	☠
L1	RLQU100KT-W	COIL	1	
L2,L3	RLQU101KT-W	COIL	2	
L4-L8	RLQU2R2MT-W	COIL	5	
L9-12	RLQU100KT-W	COIL	4	
L13,14	RLQU2R2MT-W	COIL	2	
L15	RLQU100KT-W	COIL	1	
L16	RLQU2R2MT-W	COIL	1	
L17,18	RLQP1R8KT2-Y	COIL	2	
L301	RLQZB470KT-D	COIL	1	
L303-05	RLQZP1R0KT-Y	COIL	3	
L307-10	RLQZP1R0KT-Y	COIL	4	
PCB1	REP2775AA-S	MAIN P.C.B.	1	[RTL]
PCB2	REP2683F-S	LED P.C.B.(REF.No.7)	1	

Ref. No.	Part No.	Part Name & Description	Pcs	Remarks
PCB3	REP2775AB-S	PANEL P.C.B	1	[RTL]
PCB4	REP2575A	SW P.C.B.	1	[RTL]
PCB5	REP2761A-T	SERVO P.C.B.	1	[RTL]
Q1	2SB1295-6-TB	TRANSISTOR	1	
Q2	DTC114YETL	TRANSISTOR	1	
Q3	2SB1462STX	TRANSISTOR	1	
Q5	2SB1295-6-TB	TRANSISTOR	1	
Q6	DTC114YETL	TRANSISTOR	1	
Q10	2SJ278MYTR	TRANSISTOR	1	
Q11	2SK1764KYTR	TRANSISTOR	1	
Q13	2SB1121ST-TD	TRANSISTOR	1	☠
Q301	UN5214TX	TRANSISTOR	1	
Q302,03	DTA114YUA106	TRANSISTOR	2	
Q304,05	UN5214TX	TRANSISTOR	2	
Q306	2SB709ATX	TRANSISTOR	1	
Q307	UN5214TX	TRANSISTOR	1	
Q308	UN5111TX	TRANSISTOR	1	
Q309	UN5214TX	TRANSISTOR	1	
Q315	2SB709ATX	TRANSISTOR	1	
R1	ERJ3GEYJ472V	1/16W 4.7K	1	
R2	ERJ3GEYJ102V	1/16W 1K	1	
R3	ERJ3GEYJ472V	1/16W 4.7K	1	
R5	ERJ3GEYJ1R0V	1/16W 1	1	
R6	ERJ3GEYJ472V	1/16W 4.7K	1	
R8	ERJ3GEYJ271V	1/16W 270	1	
R10	ERJ3GEYJ474V	1/16W 470K	1	
R11	ERJ3GEYJ101V	1/16W 100	1	
R12	ERJ3GEYJ223V	1/16W 22K	1	
R13	ERJ6GEYJ3R3V	1/8W 3.3	1	
R14	ERJ3GEYJ103Z	1/16W 10K	1	
R15	ERJ3GEYJ223V	1/16W 22K	1	
R16	ERJ3GEYJ104Z	1/16W 100K	1	
R17	ERJ3GEYJ223V	1/16W 22K	1	
R18	ERJ3GEYJ103Z	1/16W 10K	1	
R19	ERJ3GEYJ102V	1/16W 1K	1	
R20	ERJ3GEYJ473V	1/16W 47K	1	
R21	ERJ3GEYJ223V	1/16W 22K	1	
R22	ERJ3GEY0R00V	CHIP JUMPER	1	
R23	ERJ3GEYJ272V	1/16W 2.7K	1	
R24	ERJ3GEYJ473V	1/16W 47K	1	
R25	ERJ3GEYJ104Z	1/16W 100K	1	
R26	ERJ3GEYJ473V	1/16W 47K	1	
R28,29	ERJ3GEYJ473V	1/16W 47K	2	
R30	ERJ3GEYJ102V	1/16W 1K	1	
R31	ERJ3GEYJ223V	1/16W 22K	1	
R32	ERJ3GEYJ473V	1/16W 47K	1	
R34	ERJ3GEYJ272V	1/16W 2.7K	1	
R35	ERJ3GEYJ183V	1/16W 18K	1	
R36	ERJ3GEYJ273V	1/16W 27K	1	
R37	ERJ3GEYJ333V	1/16W 33K	1	
R38	ERJ3GEYJ223V	1/16W 22K	1	
R42	ERJ3GEYJ102V	1/16W 1K	1	

Ref. No.	Part No.	Part Name & Description	Pcs	Remarks
R43	ERJ3GEYJ222V	1/16W 1	1	
R44	ERJ3GEYJ223V	1/16W 22K	1	
R45	ERJ3GEYJ333V	1/16W 33K	1	
R46	ERJ3GEYJ222V	1/16W 1	1	
R47	ERJ3GEYJ473V	1/16W 47K	1	
R50	ERJ3GEYJ102V	1/16W 1K	1	
R55	ERJ3GEYJ332V	1/16W 3.3K	1	
R56	ERJ3GEYJ223V	1/16W 22K	1	
R58	ERJ3GEYJ682V	1/16W 6.8K	1	
R59	ERJ3GEYJ683V	1/16W 68K	1	
R60	ERJ3GEYJ332V	1/16W 3.3K	1	
R61,62	ERJ3GEYJ223V	1/16W 22K	2	
R63	ERJ3GEYJ103Z	1/16W 10K	1	
R64-66	ERJ3GEYJ471V	1/16W 470	3	
R67	ERJ3GEYJ102V	1/16W 1K	1	
R70	ERJ3GEYJ102V	1/16W 1K	1	
R71,72	ERJ3GEYJ220V	1/16W 22	2	
R73	ERJ3GEYJ393V	1/16W 39K	1	
R74	ERJ3GEYJ822V	1/16W 8.2K	1	
R75	ERJ3GEYJ223V	1/16W 22K	1	
R76	ERJ3GEYJ100V	1/16W 10	1	
R77	ERJ3GEYJ223V	1/16W 22K	1	
R78-80	ERJ3GEYJ102V	1/16W 1K	3	
R81	ERJ3GEYJ223V	1/16W 22K	1	
R82	ERJ3GEYJ473V	1/16W 47K	1	
R83	ERJ3GEYJ105V	1/16W 1M	1	
R84	ERJ3GEYJ153V	1/16W 15K	1	
R85	ERJ3GEYJ223V	1/16W 22K	1	
R86,87	ERJ3GEYJ102V	1/16W 1K	2	
R89,90	ERJ3GEYJ102V	1/16W 1K	2	
R93	ERJ3GEYJ102V	1/16W 1K	1	
R95	ERJ3GEYJ222V	1/16W 2.2K	1	
R98,99	ERJ3GEYJ102V	1/16W 1K	2	
R100	ERJ3GEYJ473V	1/16W 47K	1	
R103	ERJ3GEYJ102V	1/16W 1K	1	
R104,05	ERJ3GEYJ272V	1/16W 2.7K	2	
R107-10	ERJ3GEYJ102V	1/16W 1K	4	
R111,12	ERJ3GEYJ221V	1/16W 220	2	
R114,15	ERJ3GEYJ103Z	1/16W 10K	2	
R116,17	ERJ3GEYJ101V	1/16W 100	2	
R118	ERJ3GEYJ102V	1/16W 1K	1	
R119,20	ERJ3GEYJ101V	1/16W 100	2	
R121,22	ERJ3GEYJ272V	1/16W 2.7K	2	
R123	ERJ3GEYJ102V	1/16W 1K	1	
R124,25	ERJ3GEYJ473V	1/16W 47K	2	
R130	ERJ3GEYJ272V	1/16W 2.7K	1	
R131	ERJ3GEYJ101V	1/16W 100	1	
R132	ERJ3GEYJ272V	1/16W 2.7K	1	
R134,35	ERJ3GEYJ272V	1/16W 2.7K	2	
R137	ERJ3GEYJ103Z	1/16W 10K	1	
R145,46	ERJ3GEYJ221V	1/16W 220	2	
R147	ERJ3GEYJ102V	1/16W 1K	1	
R174	ERJ3GEYJ103Z	1/16W 10K	1	
R301	ERJ6GEYJ331V	1/10W 330	1	

Ref. No.	Part No.	Part Name & Description	Pcs	Remarks
R306	ERJ6GEYJ181V	1/19W 180	1	
R309	ERJ6GEYJ181V	1/19W 180	1	
R315	ERJ6GEYJ182V	1/10W 1.8K	1	
R316	ERDS2FJ151	1/4W 150	1	
R317,18	ERJ6GEYJ154V	1/10W 150K	2	
R319,20	ERJ6GEYJ681V	1/10W 680	2	
R321,22	ERDS2FJ100	1/4W 10	2	
R323,24	ERJ6GEYJ391V	1/10W 390	2	
R326	ERJ6GEYJ472V	1/10W 4.7K	1	
R327	ERJ6GEYJ103V	1/10W 10K	1	
R328	ERJ6GEYJ102V	1/10W 1K	1	
R329	ERJ6GEYJ101V	1/10W 100	1	
R330,31	ERJ6GEYJ102V	1/10W 1K	2	
R332	ERJ6GEYJ103V	1/10W 10K	1	
R333	ERJ6GEYJ561V	1/10W 560	1	
R334,35	ERJ6GEYJ102V	1/10W 1K	2	
R336	ERJ6GEYJ561V	1/10W 560	1	
R338	ERJ6GEYJ101V	1/10W 100	1	
R343	ERDS2FJ101	1/4W 100	1	
R344	ERJ6GEYJ102V	1/10W 1K	1	
R345,46	ERJ6GEYJ101V	1/10W 100	2	
R347,48	ERJ6GEYJ822V	1/10W 8.2K	2	
R349,50	ERJ6GEYJ272V	1/10W 2.7K	2	
R351	ERJ6GEYJ101V	1/10W 100	1	
R352,53	ERJ6GEYJ102V	1/10W 1K	2	
R354,55	ERJ6GEYJ152V	1/10W 1.5K	2	
R360	ERJ6GEYJ472V	1/10W 4.7K	1	
R362	ERDS2FJ151	1/4W 150	1	
R365	ERJ6GEYJ561V	1/10W 560	1	
R367	ERJ6GEYJ101V	1/10W 100	1	
R401,02	ERJ6GEYJ122V	1/10W 1.2K	2	
R403,04	ERJ6GEYJ152V	1/10W 1.5K	2	
R405,06	ERJ6GEYJ222V	1/10W 2.2K	2	
R407,08	ERJ6GEYJ332V	1/10W 3.3K	2	
R409,10	ERJ6GEYJ472V	1/10W 4.7K	2	
R411	ERJ6GEYJ473V	1/10W 47K	1	
R412	ERJ6GEYJ822V	1/10W 8.2K	1	
R413	ERJ6GEYJ153V	1/10W 15K	1	
R414	ERJ6GEYJ473V	1/10W 47K	1	
R415	ERJ6GEYJ822V	1/10W 8.2K	1	
R416	ERJ6GEYJ153V	1/10W 15K	1	
RX301,02	T0RX178A	OPTICAL IN	2	
S1,S2	RSH1A91ZA-A	SW,PROTECT/REFLECT	2	
S3	RSH1A044-1A	SW,LOAD OPEN	1	
S4	RSH1A91ZA-A	SW,DISC IN	1	
S5,S6	RSH1A044-1A	SW,LOAD PLAY/REC	2	
S7	RSH1A045-A	SW,LOAD TRG	1	
S8	RSP1A023-A	SW,TV SW	1	
S401-10	EVQ21405R	SW,PUSH	10	
S411,12	RST2A001-2D	SW,MARKING/TRACK	2	
TH1	RRSP33J103CW	THERMISTOR	1	

Ref. No.	Part No.	Part Name & Description	Pcs	Remarks
VR1	EVM3YSX50B14	VR,LASER POWER ADJ.	1	
X1	RSXY10M0M02T	OSCILLATOR	1	
X2	RSXC16M9S03T	OSCILLATOR	1	

## 20. Cabinet Parts Location

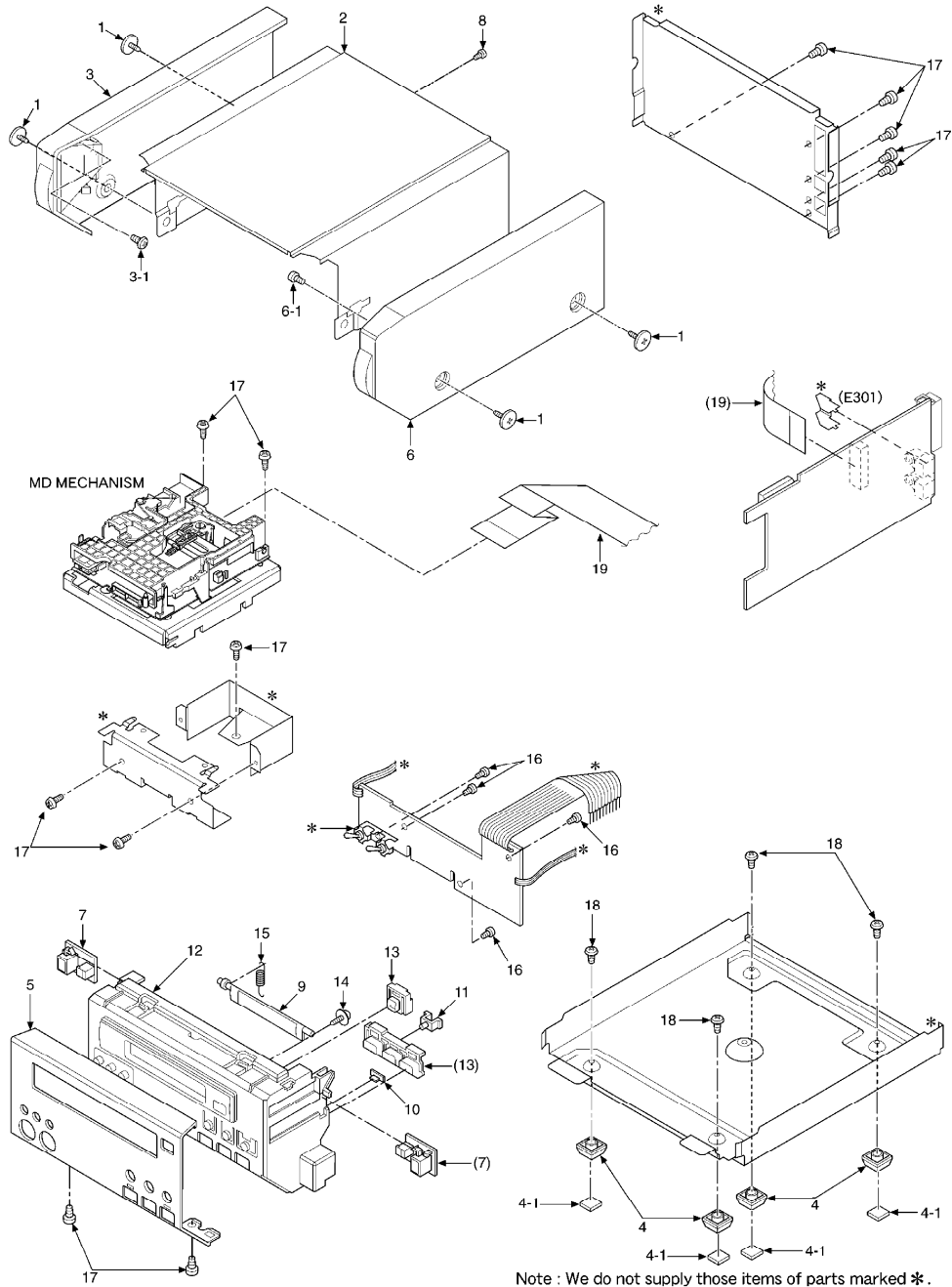

## 21. MD Mechanism Parts Location

Note: When changing loading mechanism parts, apply the specified grease to the areas marked "××" as shown in the drawing.

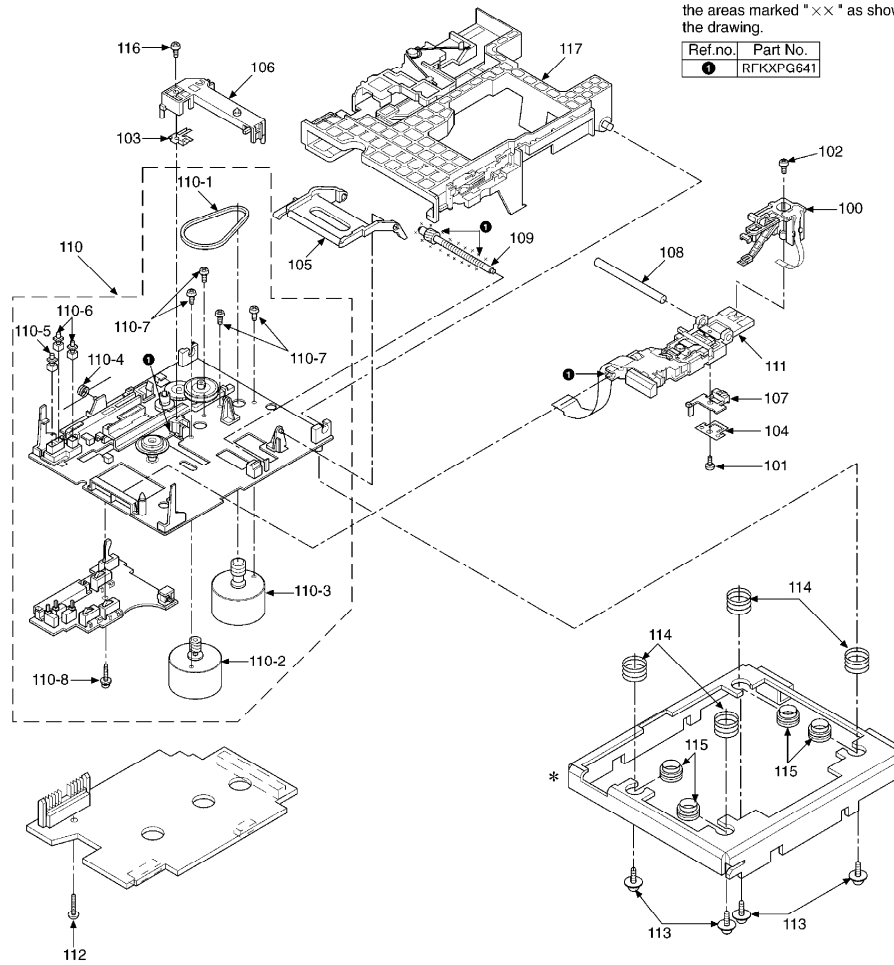

Note: We do not supply those items of parts marked \*.

**F000306000YM/KH**