

Service Manual

Turntable System SL-1000MK3

[E], [EK], [XL], [EG],[EB],
[EF], [XA], [XM], [EH], [Ei], [EC]



Areas

- * [E] is available in Switzerland and Scandinavia.
- * [EK] is available in United Kingdom.
- * [XL] is available in Australia.
- * [EG] is available in F.R. Germany.
- * [EB] is available in Belgium.
- * [EF] is available in France.
- * [XA] is available in Southeast Asia, Oceania, Africa, Middle Near East and Central South America.
- * [XM] is available in Central South America.
- * [EH] is available in Holland.
- * [Ei] is available in Italy.
- * [EC] is available in Czechoslovakia.

This SL-1000MK3 is made up of the SP-10MK3 (Quartz Direct Drive Turntable), EPA-100MK2 (Universal Tonearm), and SH-10B5 (Turntable Base).

English

Specifications

Specification are subject to change without notice for further improvement.
Weight and dimensions shown are approximate.

Power supply	: ~ 110, 120, 220, 240V 50 or 60 Hz
Power consumption	: 32.5 W
Dimensions	: 56.1 x 17.5 x 46.6cm
(W x H x D)	[Maximum height when top (dust cover) is open 48cm, Except for control unit.]
Weight	: 44kg

Deutsch

TECHNISCHE DATEN

Änderungen der technischen Daten vorbehalten.
Die angegebenen Gewichts- und Abmessungsdaten sind ungefähre Werte.

Stromversorgung	: ~ 110, 120, 220, 240 V, 50/60 Hz Wechselstrom
Leistungsaufnahme	: 32,5 W
Abmessungen	: 56,1 x 17,5 x 46,6 cm
(B x H x T)	[Maximale Höhe bei vollständig geöffneter Staubabdeckung, 48 cm, Ohne Steuereinheit.]
Gewicht	: 44 kg

Technics

Matsushita Electric Trading Co., Ltd.
P.O. Box 288, Central Osaka Japan

Français

CARACTERISTIQUES

Les spécifications sont susceptibles d'être modifiées sans préavis.
Le poids et les dimensions donnés sont approximatifs.

Alimentation	: Alternatif ~ 110, 120, 220, 240V, 50 ou 60Hz
Consommation	: 32,5W
Dimensions (L x H x P)	: 56,1 x 17,5 x 46,6cm [Hauteur maximum lorsque le dessus (couvercle protègepoussière) est ouvert 48 cm, Excepté pour la Unité de contrôle.]
Poids	: 44kg

Español

ESPECIFICACIONES

Las especificaciones quedan sujetas a cambios sin aviso previo.
El peso y las dimensiones indicados son aproximados.

Alimentación de corriente	: ~ 110, 120, 220, 240 V, 50 ó 60 Hz
Consumo de corriente	: 32,5 W
Dimensiones (Ancho x alto x profundo)	: 56,1 x 17,5 x 46,6 cm [Altura máxima cuando la parte de arriba (tapa contra el polvo) está abierta 48 cm, Excepto para el Unidad de control.]
Peso	: 44 kg

EXPLODED VIEWS

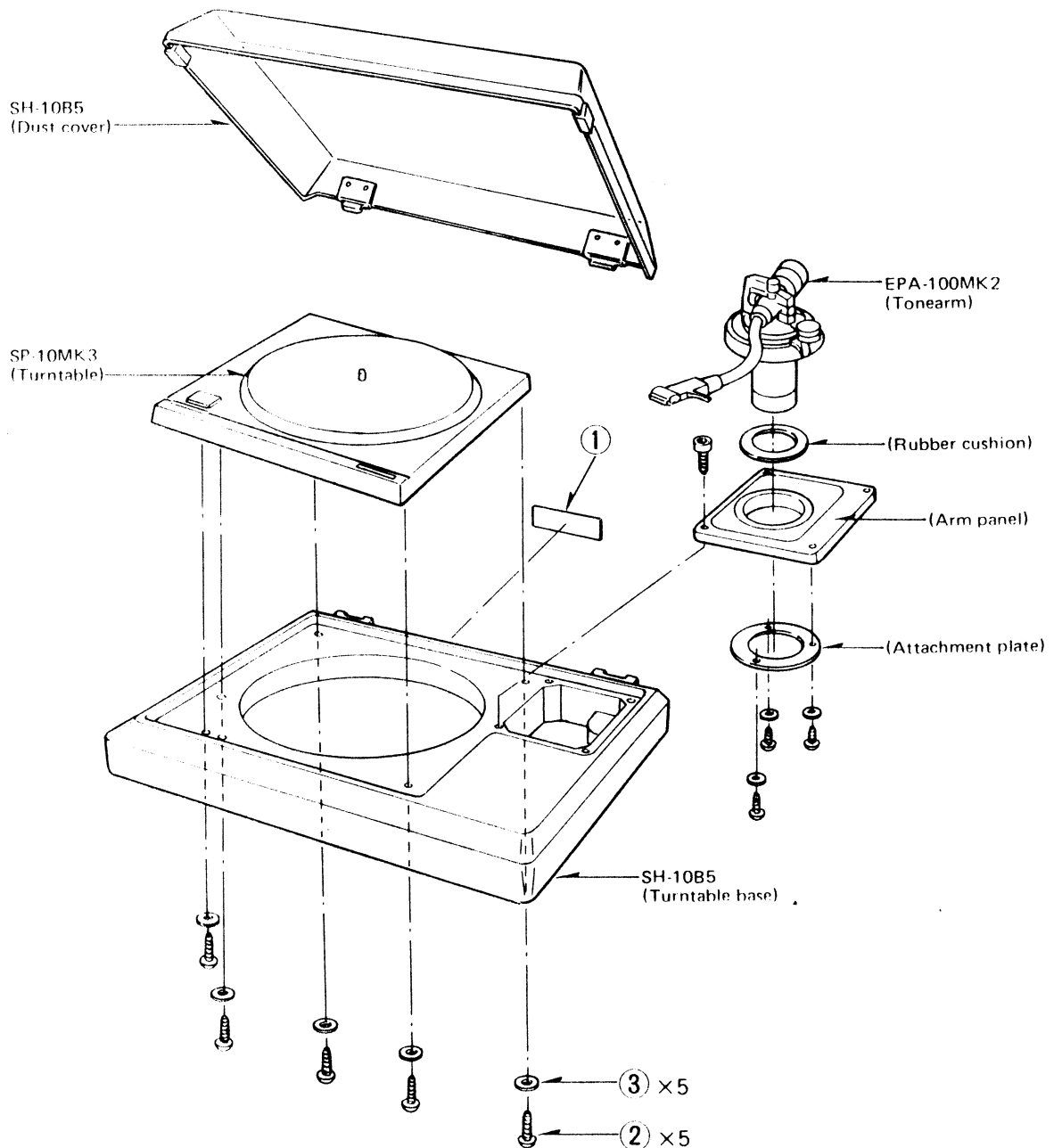

■ PACKINGS

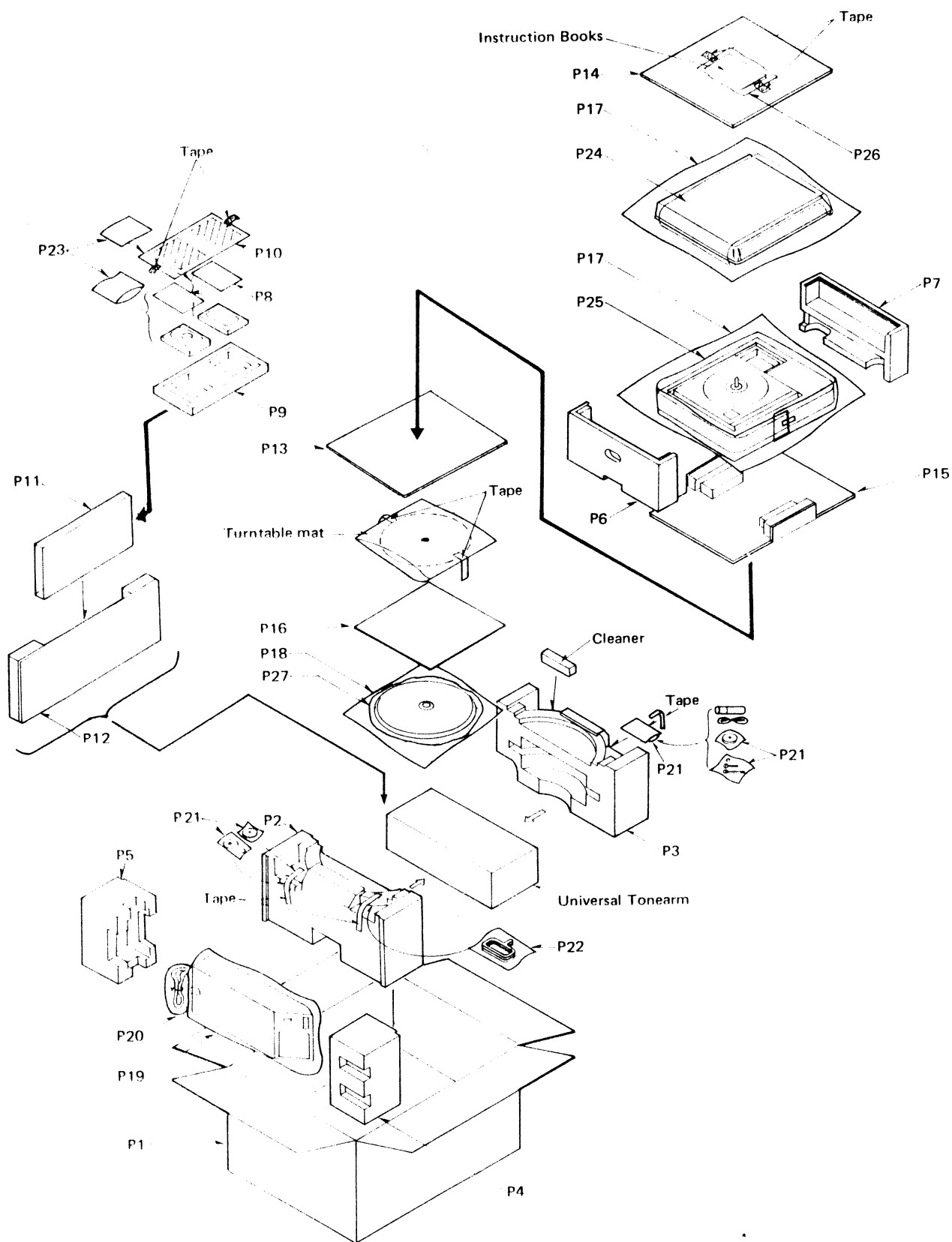

REPLACEMENT PARTS LIST

- Notes:**
1. Part numbers are indicated on most mechanical parts. Please use this parts number for parts order.
 2. Bracketed indications in Ref. No. columns specify the area. Parts without these indications can be used for all areas.
 3. The parenthesized numbers in the column of description stand for the quantity per set.

Ref. No.	Part No.	Description	Ref. No.	Part No.	Description	Ref. No.	Part No.	Description
1	SFNN113M01	Name Plate (1)	A17	SFXZ103-01	Hexagonal Wrench, Arm Panel (1)	P10	SFHD106N03	Pad, Arm Panel (1)
2	XSN5+35FZS	Mounting Screw (Turntable) (5)	A18	SFWO010	Oil Kit (1)	P11	SFHD106N02	Case, Arm Panel (1)
3	SFXW650-2	Mounting Washer (Turntable) (5)	A19	SFWF010	Adaptor, 45rpm (1)	P12	SFHD113N01	Pad, Arm Panel (1)
			A20	SFEL028-01E	Ground Wire (1)	P13	SFHD109N01	Pad, Top (Turntable Platter) (1)
			A21	SFWZ109N01E	Handle, Turntable (2)	P14	SFHD103-01	Pad, Top (Turntable Base) (1)
			A22	XSN5+60FZS	Screw, Φ 5 x 60 (5)	P15	SFHD113N02	Pad, Middle (1)
			A23	XSN5+43FZS	Screw, Φ 5 x 43 (5)	P16	SFHD109N02	Pad, Turntable Platter (1)
			A24	SFWZ109N02A	Spanner, Turntable (1)	P17	SFYF60A80	Polyethylene Bag, Turntable and Dust Cover (2)
			A25	SFWK109N01	Cloth, Cleaning (1)	P18	SFYF45C50	Polyethylene Bag, Turntable Platter (1)
			A26 (XA, XM) only	SFDK119118	2P Plug (1)	P19	SFYF28A55	Polyethylene Bag, Control Unit (1)
			PACKING PARTS			P20	SFYF10A30	Polyethylene Bag, AC Cord (1)
ACCESSORIES			P1 (Other Areas)	SFHP113M01	Carton Box (1)	P21	SFYF09A15	Polyethylene Bag, Accessories (4)
A1	SFNU113S01	Instruction Book (SL-1000MK3) (1)	P1 (EF) only	SFHP113C01	Carton Box (1)	P22	SFYF12A15	Polyethylene Bag, Handle (1)
A2	SFNU109S01	Instruction Book (SP-10MK3) (1)	P2	SFHH113N01	Pad, Left (1)	P23	SFYF17A25	Polyethylene Bag, Arm Panel (2)
A3	SFNU106S01	Instruction Book (SH-10R5) (1)	P3	SFHH113N02	Pad, Right (1)	P24	SFHZ144X02	Sheet, Dust Cover (1)
A4	SFPDS1M202	Instruction Book (EPA-100MF2) (1)	P4	SFHH113N03	Pad, Front (Control Unit) (1)	P25	SFHZ106N01	Pad (1)
A5	SFNZ109M04	Caution Book (Cleaner) (1)	P5	SFHH113N04	Pad, Rear (Control Unit) (1)	P26	SFYF27A40	Polyethylene Bag, Instruction Book (1)
A6	SFPDS1M209	Damping Selector Diagram (1)	P6	SFHH101-08	Pad, Left (Turntable Base) (1)	P27	SFHZ109N03	Anti-Rust Paper (1)
A7	SFNZ106N01	Tonearm Installation Diagram (1)	P7	SFHH106N01	Pad, Right (Turntable Base) (1)	P28	SFHZ109N01	Sheet, Cord (1)
A8	SFNZ109M01	Mounting Map (1)	P8	SFHZ106N02	Sheet, Arm Panel (2)			
A9	SFNZ106M11	Caution Label, Cleaning (1)	P9	SFHH106N02	Pad, Arm Panel (1)			
A10	SFWZ109N03	Cleaner, Turntable (1)						
A11	SFHP109N02	Case, Cleaner (1)						
A12	SFNZ109N05	Label, Cleaner (2)						
A13	SFWK106N01	Cloth, Cleaning (1)						
A14	SFAZ106N02A	Arm Panel (1)						
A15	SFAZ106N03A	Arm Panel (1)						
A16	XVES5B30X1S	Arm Panel Fixing Screw (4)						

Service Manual

QUARTZ Direct Drive Turntable
SP-10MK3



Specifications

Specifications are subject to change without notice for further improvement.
Weight and dimensions shown are approximate.

■ General

Power supply: ~ 110/120/220/240V, 50 or 60Hz
Power consumption: 32.5 W
Dimensions (H×W×D):
(Turntable unit) 11.3×36.9×36.9 cm
4-7/16×14-17/32×14-17/32 inches
(Control unit) 9.6×16.6×41 cm
3-3/4×6-17/32×16-1/8 inches
Weight: 18 kg (40 lb) (Turntable unit)
6 kg (13 lb) (Control unit)

■ Turntable section

Type: Direct drive turntable with quartz synthesizer pitch control
Turntable platter: Copper alloy and die-cast aluminum diameter 32 cm (12-19/32"), weight 10 kg (22 lb)
Moment of inertia: 1.1 ton•cm² (1,100 kg•cm²)
Motor: Quartz-phase-locked, ultra-low speed, brushless DC motor

Turntable speeds: 33-1/3, 45 and 78.26 rpm
Turntable speed fine adjustment: Quartz locked, pitch adjustable in 0.1% steps up to ±9.9%
Starting torque: 16 kg•cm
Start-up time: 0.25 s. (33-1/3 rpm)
Braking time: 0.3 s. (33-1/3 rpm)
Speed fluctuation due to load torque: 0% within 10 kg•cm
Speed drift: Within ±0.001%
Wow and flutter: 0.015% WRMS (JIS C5521)
±0.021% weighted zero to peak (DIN 45500, IEC 98A weighted)
(System tested: SP-10MK3 + SH-10B5+EPA-250+ EPC-100CMK3)
Rumble: -92 dB DIN B (IEC 98A weighted)
-60 dB DIN A (IEC 98A unweighted)

Technics

CONTENTS

	Page
LOCATION OF CONTROLS	2, 3
DISASSEMBLY INSTRUCTIONS	4 ~ 7
HOW TO CHECK THE PRINTED CIRCUIT BOARD	8
MEASUREMENTS AND ADJUSTMENT	9 ~ 11
RESISTORS AND CAPACITORS	11, 12
PRINTED CIRCUIT BOARD	
WIRING CONNECTION DIAGRAM	13, 14
BLOCK DIAGRAM	15
PRINTED CIRCUIT BOARDS	
Driving circuit	16, 17
Turntable unit (Speed selector & strobe circuit)	16, 17
Control circuit	22
Operation circuit	27
Constant voltage & operation circuit	31
power supply circuit	35

	Page
SCHEMATIC DIAGRAM	
Driving circuit	19, 20
Turntable unit (Speed selector & Strobe circuit)	21
Control circuit	25, 26
Operation circuit	29, 30
Constant voltage & operation circuit	33, 34
Power supply circuit	35
REPLACEMENT PARTS LIST (Electric Parts)	35
EXPLODED VIEWS	36 ~ 38
REPLACEMENT PARTS LIST	
(Cabinet and Chassis Parts)	39

LOCATION OF CONTROLS

- Turntable unit

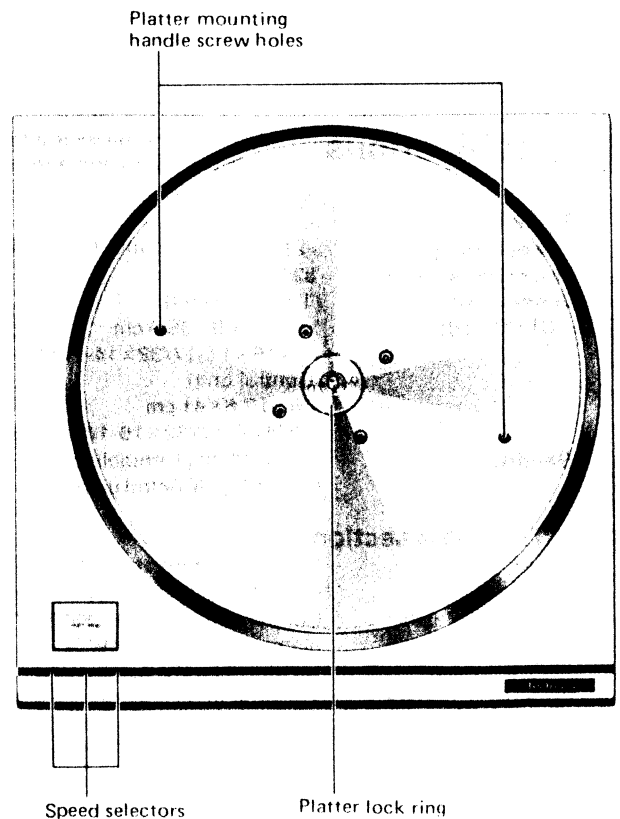

DEUTSCH

■ TECHNISCHE DATEN

Alle Angaben sind nominell, wenn nicht anders angegeben.
 Die Werte beziehen sich auf die Nennleistung und -spannung.

<p>■ Allgemeine Daten</p> <p>Stromversorgung: ~ 110-120V / 220-240V 50/60 Hz Wechselstrom 32,5 W</p> <p>Leistungsaufnahme: 32,5 W</p> <p>Abmessungen (H x B x T): (Plattenspieler Einheit) 11,3 x 38,9 x 26,9 cm (Steuereinheit) 9,6 x 16,6 x 41 cm</p> <p>Gewicht: 13 kg (Plattenspieler Einheit) 6 kg (Steuereinheit)</p> <p>■ Plattenspieler</p> <p>Typ: Direktantriebs-Plattenspieler mit Quarz-Synthesizer-Drehzahlregelung</p> <p>Plattenteller: Kupferlegierung und Aluminium-Spritzguß; Durchmesser 32 cm, Gewicht 10 kg 1,1 Tonnen/cm²</p> <p>Trägheitsmoment: 1,1 Tonnen·cm²</p> <p>Motor: Quarzphasen-gesteuerter, ultralangsam- kollektorloser Gleichstrommotor</p> <p>Plattenteller-Drehzahlen: 33-1/3 45 und U/min 78,26 U/min</p>	<p>Drehzahl-Feinregulierung: 2,4 (unbest.)- bis 2,0 (best.) U/min (unbest.) bis 1,6 (best.) U/min</p> <p>Anlaufdrehmoment: 16 kg·cm</p> <p>Hochlaufzeit: 0,25 s (30-1/3 U/min)</p> <p>Bremszeit: 0,3 s (33-1/3 U/min)</p> <p>Drehzahlschwankungen aufgrund von Lastdrehmoment: 0% (innerhalb 10 kg·cm)</p> <p>Drehzahlabweichung: innerhalb ±0,001%</p> <p>Gleichlaufschwankungen: 0,015% WRMS (JIS C5521) ±0,021% bewertet Null-Zu-Spitze (DIN 45 500 IEC 98A bewertet) (getestetes System) SP-10MK3 + SH-10B5 + EPA-250 + EPD-100CMK3</p> <p>Rumpel-Fremdspannungsabstand: -92 dB DIN B (IEC 98A bewertet)</p> <p>Rumpel-Geräuschspannungsabstand: -60 dB DIN A (IEC 98A un bewertet)</p>
---	--

■ JUSTIERUNGEN

● Zu verwendende Instrumente und Einstellungen

1. Gleichstrom-Voltmeter
2. Oszilloskop
3. Gleichstromversorgung
4. Den Drehzahlregler auf 0% einstellen.

Gegenstand	Vorbereitungen	Zu justierende Teile	Justiermethode
Konstantspannungs-Stromversorgung	1. Die Anschlüsse CN1, CN2 und CN3 herausziehen. 2. Das Gleichstrom-Voltmeter entweder an den CN1-Anschluß ③ (+) und BT1-Anschluß ③ (-) oder die negative Seite von C3 anschließen. 3. Den Netzschalter einschalten.	VR1	1. VR1 auf einen Ausgang von 31,8V abgleichen.
	1. Die Anschlüsse CN1, CN2 und CN3 herausziehen. 2. Das Gleichstrom-Voltmeter entweder an den CN1-Anschluß ③ (+) und BT1-Anschluß ③ (-) oder die negative Seite von C3. 3. Den Netzschalter einschalten.	VR2	1. VR2 auf einen Ausgang von -31,8V abgleichen.
Kristalloszillation	1. Das Oszilloskop an C202 Stift 7 und den Erdungsanschluß anschließen. 2. Den Netzschalter einschalten.	Q211	1. Q211 so justieren, daß der Zyklus 0,31 µsec (262,98 kHz) beträgt.

Gegenstand	Vorbereitungen	Zu justierende Teile	Justiermethode						
VS-Spannung	<ol style="list-style-type: none"> Das Gleichstrom-Voltmeter an CN206 Anschluß 3 (+) und CN206 Anschluß 1 (-) anschließen. Den Netzschalter einschalten und den Drehzahl-Wahlschalter auf "33 U/min." einstellen. 	VR201	<ol style="list-style-type: none"> VR201 so justieren, daß die Ausgangsspannung 2,1V beträgt. 						
RS-Strom	<ol style="list-style-type: none"> Das Gleichstrom-Voltmeter an CN206 Anschluß ⑤ (+) und CN206 Anschluß ④ (-) anschließen. Den Netzschalter einschalten und den Drehzahl-Wahlschalter auf "33 U/min." einstellen. Die Start-Taste drücken. 	VR206	<ol style="list-style-type: none"> VR206 so justieren, daß die Ausgangsspannung 0V beträgt. 						
Synchronisierungs-Position	<ol style="list-style-type: none"> Das Oszilloskop an CN206 Anschluß ② (+) und CN206 Anschluß 1 (-) anschließen. Den Netzschalter einschalten und die Start-Taste drücken. 	VR200 33 U/min VR204 45 U/min VR205 78 U/min	<p>Den Drehzahl-Wahlschalter nacheinander auf "33", "45" und "78" umschalten und VR203, VR204 und VR205 so justieren, daß die Zeiten gemäß nachstehender Tabelle sind:</p> <table border="1"> <tr> <td>33</td> <td>3,5ms</td> </tr> <tr> <td>45</td> <td>5,5ms</td> </tr> <tr> <td>78</td> <td>6,5ms</td> </tr> </table> 	33	3,5ms	45	5,5ms	78	6,5ms
33	3,5ms								
45	5,5ms								
78	6,5ms								
Bremse (elektrisch)	<ol style="list-style-type: none"> Den Anschluß CN202 herausziehen. (Bei gelöster mechanischer Bremse!) Den Netzschalter einschalten und den Drehzahl-Wahlschalter auf "33 U/min." einstellen. Die Start-Taste drücken. 	VR202	<ol style="list-style-type: none"> Die Stoptaste drücken. VR202 so justieren, daß der Bereich des Winkels um den Stopp der Drehung $90^\circ \sim 180^\circ$ beträgt. 						
Offset-Spannung	<ol style="list-style-type: none"> 40mV zwischen CN203 Anschlüsse ② und ③ mit der Gleichspannungsversorgung anlegen. Das Gleichstrom-Voltmeter zwischen CN102 Anschlüsse ③ und ④ anschließen. Den Netzschalter einschalten und die Start-Taste drücken. 	VR101	<ol style="list-style-type: none"> VR101 so justieren, daß die Ausgangsspannung 10mV beträgt. 						
Mittelspannung	<ol style="list-style-type: none"> Das Gleichstrom-Voltmeter zwischen CN102 Anschlüsse ① und ② anschließen. Den Netzschalter einschalten und die Start-Taste drücken. 	VR102	<ol style="list-style-type: none"> VR102 so justieren, daß die Ausgangsspannung 0V beträgt. 						

*** Justiermethode ohne Gleichstromversorgung für die Offsetspannungs-Justierung**

- 3 Widerstände an die Antriebsschaltungs-Platine anlöten. (Siehe Abb. 21)
- Den CN203-Stecker herausziehen. (Steuerschaltungs-Platine).
- CN203 Anschluß ⑤ an BT102 Anschluß ⑤, und CN203 Anschluß ④ an BT102 Anschluß ④ über Anschlußdrähte mit Klemmen anschließen.
- Das Gleichstrom-Voltmeter zwischen CN102 Anschlüsse ③ und ④ anschließen.
- Den Netzschalter einschalten und die Start-Taste drücken.
- VR101 so justieren, daß das Gleichstrom-Voltmeter 10mV anzeigt.
- Die 3 Widerstände und die Anschlußdrähte entfernen.

• Justierung der mechanischen Bremse

1. Justierung der Hebelbremse

- Den Plattenteller abnehmen.
- Die Hebelbremse-Justierschraube lösen.
- Das Solenoid nach links und rechts bewegen, so daß ein Abstand von ca. 2mm zwischen dem Solenoid und dem Stoppergummi entsteht.

- Die Hebelbremse-Justierschraube anziehen.

- Den Plattenteller aufsetzen und überprüfen, daß der Plattenteller sich nicht bewegt, wenn der Netzschalter ausgeschaltet ist.

2. Justierung der Bandbremse

*** Überprüfung der Bandposition**

- Den Plattenteller abnehmen.
- Die innere Peripherie des Bandes sollte mit der inneren Peripherie des Gehäuses übereinstimmen.
- Falls sie voneinander abweichen, durch Lösen der Justierschrauben an zwei Stellen justieren.

*** Überprüfung des Bremswinkels**

- Den Plattenteller drehen.
- Die Stoptaste drücken und überprüfen, daß der Bereich des Winkels zum Stoppen der Drehung 40° oder weniger beträgt.
- Falls der Stoppwinkel über 40° beträgt, zuerst die elektrische Bremse justieren.
- Anschließend die Justierungsplatten-Einstellschraube lösen und den Justierknopf so drehen, daß der Winkel 40° oder weniger wird.

FRANÇAIS

■ CARACTERISTIQUES

Les spécifications sont susceptibles d'être modifiées sans préavis.
Les poids et les dimensions donnés sont approximatifs.

■ Généralités Alimentation: Alternatif 110-120/220-240V, 50 ou 60 Hz Consommation: 32,5 W Dimensions: (H x L x P) (Unité du tourne-disque): 11,2 x 36,0 x 36,9 cm 47,16 x 14,17/32 x 14,17/32 cm (Unité de contrôle): 9,5 x 18,3 x 11,7 cm 3,74 x 7,27 x 4,61 (8 pouces) 18,3 x 40 (bras) (Unité du tourne-disque): 6 kg (13 livres) (Unité de contrôle)		Vitesses de rotation: 33-1/3, 45 et 78,26 t/p.m. Réglage précis de la vitesse de la platine: Blocage par quartz, écart réglable par étapes de 0,1% jusqu'à ±0,3%, 1,6 kg/cm Couple de démarrage: 0,25 s (33-1/3 t/p.m.) Durée de démarrage: 0,2 s (33-1/3 t/p.m.) Durée de freinage: 0,2 s (33-1/3 t/p.m.) Variation de la vitesse due au couple de charge: 1% en sera de 10 kg/cm Déviations du nombre de tours: En sera de ±0,001% Pleurage et scintillement: 0,015% de valeur efficace (JIS C3521) Ronflement: ±0,021% de zéro pondéré à la norme (DIN 45 500, IEC 98A pondéré) (Dispositif essayé: SP-10MK3 + SH-10B5 + EPA-250 + EPC-100CMK3) -92 dB DIN B (IEC 98A pondéré) -60 dB DIN A (IEC 98A non-pondéré)	
■ Platine de lecture Type: Platine à entraînement direct avec réglage d'écart à synthétiseur à quartz. Plateau de la platine: Alliage en cuivre et aluminium moulé sous pression. Diamètre de 32 cm; poids de 10 kg, 1,1 tonne.cm ² (1,100 kg.cm ²). Moment d'inertie: Moteur à C.C. sans palai, à vitesse ultra-faible et à accrochage de phase par quartz.			

■ RÉGLAGES

● Instruments utilisés et réglages

1. Voltmètre à C.C.
2. Oscilloscope
3. Alimentation en courant C.C.
4. Régler la commande d'écart sur 0%.

Article	Préparatifs	Éléments de réglage	Méthode de réglage
Alimentation en tension constante	1. Retirer les connecteurs CN1, CN2 et CN3. 2. Brancher le voltmètre à C.C. soit à la borne ③ (+) de CN1 et à la borne ④ (-) de BT1 soit au côté négatif de C3. 3. Tourner l'interrupteur d'alimentation sur "on" (marche).	VR1	1. Ajuster VR1 de façon à ce que la tension de sortie soit de 31,8V.
	1. Retirer les connecteurs CN1, CN2 et CN3. 2. Brancher le voltmètre à C.C. soit à la borne ① (-) de CN1 et à la borne ③ (-) de BT1 soit au côté négatif de C3. 3. Tourner l'interrupteur d'alimentation sur "on" (marche).	VR2	1. Ajuster VR2 de façon à ce que la tension de sortie soit de -31,8V.
Oscillateur à cristal	1. Brancher l'oscilloscope à l'ergot 7 de IC202 et à la borne de mise à la terre. 2. Tourner l'interrupteur d'alimentation sur "on" (marche).	C211	1. Ajuster C211 de façon à ce que le cycle soit de 3,81 μsec. (262,08 kHz).

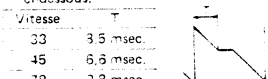
Article	Préparatifs	Éléments de réglage	Méthode de réglage								
Tension VS	1. Brancher le voltmètre à C.C. à la borne ③ (+) de CN206 et à la borne ① (-) de CN206. 2. Tourner l'interrupteur d'alimentation sur "on" (marche) et régler le sélecteur de vitesse sur "33 r.p.m." (t/p.m.).	VR201	1. Ajuster VR201 de façon à ce que la tension de sortie soit de 2,1V.								
Courant RS	1. Brancher le voltmètre à C.C. à la borne ③ (+) de CN206 et à la borne ④ (-) de CN206. 2. Tourner l'interrupteur d'alimentation sur "on" (marche) et régler le sélecteur de vitesse sur "33 r.p.m." (t/p.m.). 3. Appuyer sur la touche de démarrage.	VR206	1. Ajuster VR206 de façon à ce que la tension de sortie soit de 0V.								
Position de synchronisation	1. Brancher l'oscilloscope à la borne ② (+) de CN206 et à la borne ① (-) de CN206. 2. Tourner l'interrupteur d'alimentation sur "on" (marche) et appuyer sur la touche de démarrage.	VR203 33 t/p.m. VR204 45 t/p.m. VR205 78 t/p.m.	1. Commuter le sélecteur de vitesse sur "33", "45" et "78" et ajuster VR203, VR204 et VR205 de façon à ce que la durée de T soit telle que dans la table ci-dessous.  <table border="1"> <thead> <tr> <th>Vitesse</th> <th>T</th> </tr> </thead> <tbody> <tr> <td>33</td> <td>3,5 msec.</td> </tr> <tr> <td>45</td> <td>6,6 msec.</td> </tr> <tr> <td>78</td> <td>3,8 msec.</td> </tr> </tbody> </table>	Vitesse	T	33	3,5 msec.	45	6,6 msec.	78	3,8 msec.
Vitesse	T										
33	3,5 msec.										
45	6,6 msec.										
78	3,8 msec.										
Frein (électrique)	1. Retirer le connecteur CN202 (avec le frein mécanique libéré). 2. Tourner l'interrupteur d'alimentation sur "on" (marche) et régler le sélecteur de vitesse sur "33 r.p.m." (t/p.m.) 3. Appuyer sur la touche de démarrage.	VR202	1. Appuyer sur la touche d'arrêt. 2. Ajuster VR202 de façon à ce que la plage de l'angle pour l'arrêt de la rotation soit de 90° ~ 180°.								
Tension de suppression	1. Appliquer 40mV entre les bornes ② et ③ de CN203 avec l'alimentation en courant C.C. 2. Brancher le voltmètre à C.C. entre les bornes ③ et ④ de CN102. 3. Tourner l'interrupteur d'alimentation sur "on" (marche) et appuyer sur la touche de démarrage.	VR101	1. Ajuster VR101 de façon à ce que la tension de sortie soit de 10mV.								
Tension intermédiaire	1. Brancher le voltmètre à C.C. entre les bornes ① et ② de CN102. 2. Tourner l'interrupteur d'alimentation sur "on" (marche) et appuyer sur la touche de démarrage.	VR102	1. Ajuster VR102 de façon à ce que la tension de sortie soit de 0V.								

* Méthode de mise au point sans alimentation en courant C.C. pour le réglage de la tension de suppression.

1. Souder 3 résistances à la plaquette à circuits imprimés du circuit d'attaque. (Se référer à la Fig. 21.)
2. Retirer le connecteur CN203. (Plaquette à circuits imprimés du circuit de commande.)
3. Connecter la borne ⑤ de CN203 à la borne ⑤ de BT102 et la borne ④ de CN203 à la borne ④ de BT102, en utilisant un fil de jonction avec pince, etc.
4. Brancher le voltmètre à C.C. entre les bornes ③ et ④ de CN102.
5. Tourner l'interrupteur d'alimentation sur "on" (marche) et appuyer sur la touche de démarrage.
6. Ajuster VR101 de façon à ce que la lecture du voltmètre à C.C. soit de 10mV.
7. Retirer les trois résistances et le fil de jonction.

3. Déplacer le solénoïde de droite à gauche de façon à ce que l'intervalle entre le solénoïde et le caoutchouc de la pièce d'arrêt soit d'à peu près 2 mm.
4. Serrer la vis de réglage du frein à levier.
5. Monter la platine et vérifier qu'elle ne bouge pas avec l'interrupteur d'alimentation réglé sur "off" (hors circuit).

2. Ajustement du frein du ruban

* Vérifier la position de la bande.

1. Retirer la platine.
2. La périphérie interne de la bande devra coïncider avec la périphérie interne du logement.
3. Si elles sont déviées, ajuster en desserrant les vis de réglage aux deux endroits.

* Vérifier l'angle de freinage

1. Faire tourner la platine.
2. Appuyer sur la touche d'arrêt et vérifier que la plage de l'angle pour l'arrêt de la rotation soit de 40° ou moins.
3. Si l'angle d'arrêt est au-dessus de 40°, régler préalablement le frein électrique.
4. Ensuite, desserrer la vis de réglage de la plaque d'ajustage et tourner le bouton de réglage de façon à ce que l'angle soit de 40° ou moins.

● Réglage du frein mécanique

1. Ajustement du frein du levier

1. Retirer la platine.
2. Desserrer la vis de réglage du frein à levier.

ESPAÑOL

■ ESPECIFICACIONES

Las especificaciones quedan sujetas a cambios sin aviso previo. El peso y las dimensiones indicados son aproximados.

■ En general Alimentación de corriente: ~ 110-120/220-240 V, 50/60 Hz Consumo de corriente: 32,5 W Dimensiones: (Alto x Ancho x Prof.) (Equipo del plato giratorio) 11,3 x 36,9 x 36,9 cm (Unidad de control) 9,6 x 16,6 x 41 cm Peso: 18 kg (Equipo del plato giratorio) 5 kg (Unidad de control)		Ajuste exacto de la velocidad del plato giratorio: Ajuste de la altura de sonido en pasos de 0,1% hasta aproximadamente 9,9%, con bloqueo por cuarzo Par motor de arranque: 16 kg/cm Tiempo de puesta en marcha: 0,25 s (33-45 rpm) Tiempo de frenado: 0,2 s (33-45 rpm) Variación de velocidad debido al par de carga: 0% dentro de 10 kg/cm Desplazamiento de velocidad: Menos de ±0,001% Ululaciones y trémolo: ±0,021% Ruido de rodadura: Ponderado cero a cresta (DIN 45 500, IEC98A Ponderado) (Probado por sistemas: SP-10MK3 + SH-10B5 + EPA-250 + EPC-100CMK3) -92 dB DIN B (IEC 98A Ponderado) -60 dB DIN A (IEC 98A No ponderado)	
■ Sección del plato giratorio Tipo: Plato giratorio de accionamiento directo con control de altura de sonido por sintetizador de cuarzo Platillo del plato giratorio: Aleación de cobre y aluminio fundido Diámetro de 32 cm (12-19/32") Peso: 10 kg (22 lbs.) 1,1 t·cm ² (1,100 kg·cm ²) Momento de inercia: Motor de corriente continua sin escobillas con velocidad ultrarápida, de enganche de fase por cuarzo Motor: Velocidades del plato giratorio: 33-1/3, 45 y 78,26 rpm			

■ AJUSTES

● Instrumentos usados y puestas

1. Voltímetro DV
2. Osciloscopio
3. Fuente de alimentación CC

4. Ponga el control de altura en 0%

Item	Preparaciones	Piezas de ajuste	Método de ajuste
Fuente de alimentación de voltaje constante	1. Saque los conectores CN1, CN2 y CN3. 2. Conecte el voltímetro CC ya al terminal ③ (+) CN1 y terminal ④ (-) BT1 o ya al lado negativo de C3. 3. Ponga el interruptor de corriente en "on".	VR1	1. Ajustar VR1 de manera que el voltaje de salida sea 31,8V.
	1. Saque los conectores CN1, CN2 y CN3. 2. Conecte el voltímetro CC ya al terminal ① (+) CN1 y terminal ③ (-) BT1 o ya al lado negativo de C3. 3. Ponga el interruptor de corriente en "on".	VR2	1. Ajustar VR2 de manera que el voltaje de salida sea -31,8V.
Oscilación de cristal	1. Conecte el osciloscopio a púa ⑦ de IC202 y terminal de tierra. 2. Ponga el interruptor de corriente en "on".	C211	1. Ajustar C211 de manera que el ciclo sea 3,81 μseg. (262,08 kHz).

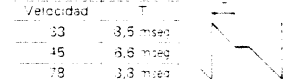
Item	Preparaciones	Piezas de ajuste	Método de ajuste
Voltaje VS	1. Conecte el voltímetro CC a terminal ③ (+) CN206 y terminal ① (-) CN206. 2. Ponga el interruptor de corriente en "on" y fije el selector de velocidad a "33 r.p.m.".	VR201	1. Ajustar VR201 de manera que el voltaje de salida sea 2,1V.
Corriente RS	1. Conecte el voltímetro CC a terminal ⑤ (+) CN206 y terminal ④ (-) CN206. 2. Ponga el interruptor de corriente en "on" y fije el selector de velocidad a "33 r.p.m.".	VR206	1. Ajustar VR206 de manera que el voltaje de salida sea 0V.
Posición de sincronización	1. Conecte el osciloscopio a terminal ② (+) CN206 y terminal ① (-) CN206. 2. Ponga el interruptor de corriente en "on" y apriete el botón de arranque.	VR203 (33 rpm) VR204 (45 rpm) VR205 (78 rpm)	1. Conmutar el selector de velocidad a "33", "45" y "78" y ajustar VR203, VR204 y VR205 de manera que el tiempo T este como en la tabla de abajo. 
Freno (eléctrico)	1. Saque el conector CN202. (Con el freno mecánico soltado). 2. Ponga el interruptor de corriente en "on" y fije el selector de velocidad a "33 r.p.m.".	VR202	1. Apriete el botón de arranque. 2. Ajustar VR202 de manera que el ángulo para parada de rotación sea 90° ~ 130°.
Contravoltaje	1. Aplique 40mV entre terminales ② y ③ CN203 mediante la fuente de alimentación CC. 2. Conecte el voltímetro CC entre terminales ③ y ④ CN102. 3. Ponga el interruptor de corriente en "on" y apriete el botón de arranque.	VR101	1. Ajustar VR101 de manera que el voltaje de salida sea 10mV.
Voltaje medio	1. Conecte el voltímetro CC entre terminales ① y ② CN102. 2. Ponga el interruptor de corriente en "on" y apriete el botón de arranque.	VR102	1. Ajustar VR102 de manera que el voltaje de salida sea 0V.

* Método de ajuste sin fuente de alimentación CC para ajuste de contravoltaje

1. Suelde 3 resistores al circuito excitador p.c.B. (Refiera a la Fig. 21)
2. Saque el tornillo de CN203. (Circuito de control p.c.B.)
3. Conecte el terminal ⑤ de CN203 al terminal ⑤ de BT102 y el terminal ④ de CN203 al terminal ④ de BT102, usando un hilo conductor con presilla, etc.
4. Conecte el voltímetro de CC entre terminales ③ y ④ de CN102.
5. Ponga el interruptor de la corriente en "on" (conectado) y apriete el botón de arranque.
6. Ajuste VR101 de manera que la lectura del voltímetro de CC sea 10mV.
7. Remueva los 3 resistores y el hilo conductor.

● Ajuste del Freno Mecánico

1. Ajuste del freno de palanca

1. Remueva el plato giradiscos.
2. Afloje el tornillo de ajuste de freno de palanca.
3. Mueva el solenoide de derecha a izquierda de manera que la separación entre el solenoide y el caucho de retenedor sea unos 2 mm.
4. Apriete el tornillo de ajuste de freno de palanca.
5. Monte el plato giradiscos y compruebe para ver que el plato giradiscos no se mueva con el interruptor de la corriente puesto en "off" (desconectado).

2. Ajuste del freno de banda

* Comprobación de la posición de banda

1. Remueva el plato giradiscos.
2. La periferia interna de la banda debería coincidir con la periferia interna de la caja.
3. Si ellas están desviadas, ajústelo aflojando los tornillos de ajuste en 2 posiciones.

* Comprobación del ángulo de freno

1. Gire el plato giradiscos.
2. Apriete el botón de arranque y compruebe para ver que el ángulo de parada de la rotación sea 40° o menos.
3. Si el ángulo de parada es más de 40°, ajuste, de antemano, el freno eléctrico.
4. A continuación, afloje el tornillo de sujeción de placa de ajuste y gire la perilla de ajuste de manera que el ángulo sea 40° o menos.

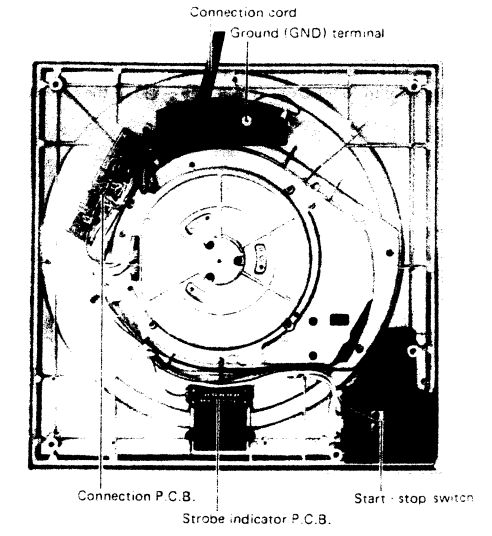
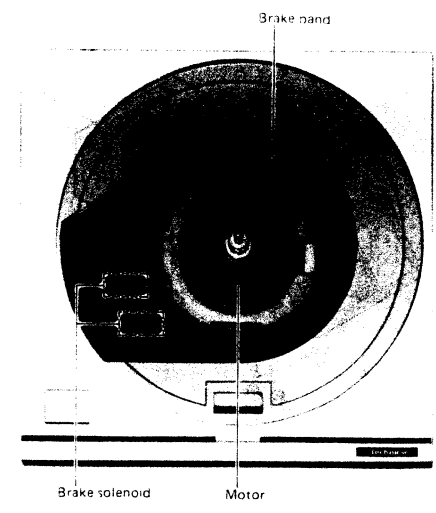

• Control unit

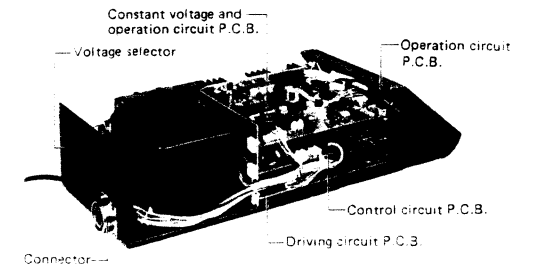
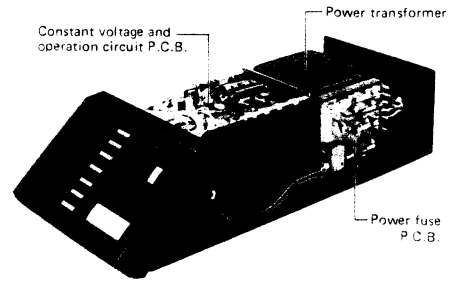
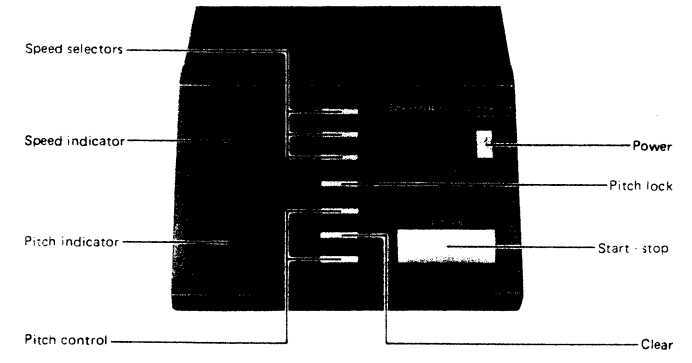

DISASSEMBLY INSTRUCTIONS

1. Control unit

• **How to remove the cabinet**

1. Remove the 8 setscrews (Fig. 1 : ① ~ ⑧) of the cabinet.

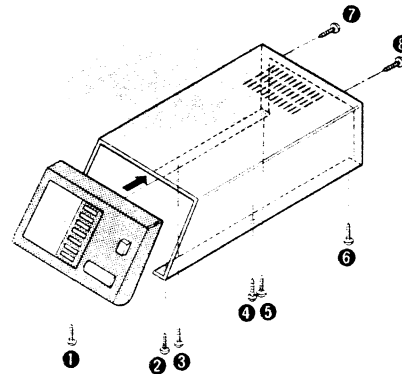

Fig. 1

• **How to remove the front panel**

1. Remove the cabinet.
2. Remove the 4 setscrews (Fig. 2 : ⑨ ~ ⑫) of the front panel.
3. Pull out the connectors CN2 and CN403 of the constant voltage and operation circuit P.C.B., and remove the panel in the direction of the arrow. (Fig. 2)

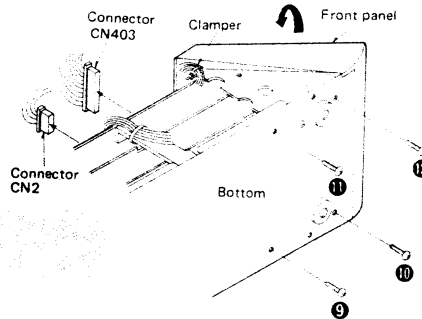

Fig. 2

• **When removing the front panel**

1. Remove the 4 setscrews (Fig. 3 : ⑬ ~ ⑯) of the bracket.
2. Remove the 4 setscrews (Fig. 4 : ⑰ ~ ⑳) of the front panel to remove the panel.

• **How to remove the operation circuit P.C.B.**

1. Remove the cabinet and front panel.
2. Remove the bracket.
3. Remove the 3 setscrews (Fig. 3 : ⑰ ~ ⑳) of the printed circuit board.
4. Loosen 2 claws upward to remove them from the printed board. (Fig. 3)
5. Remove the printed circuit board in the direction of the arrow A. (Fig. 3)

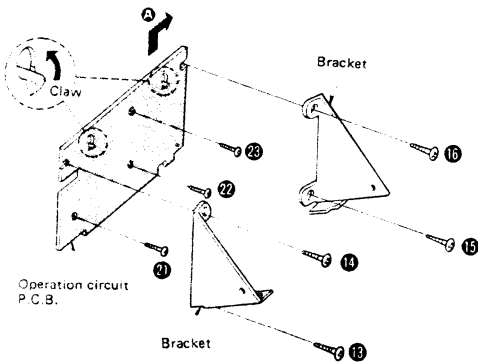

Fig. 3

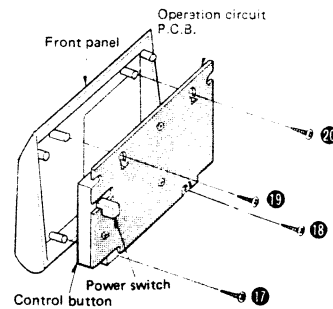

Fig. 4

• **How to remove the control buttons (Start/stop, speed selector/pitch control) and the power switch.**

1. Remove the cabinet and front panel.
2. Remove the operation circuit P.C.B.
3. Remove the setscrews ⑳ and ㉑ in Fig. 5 to remove the power switch.
4. Remove the setscrews ㉒ ~ ㉔ in Fig. 5 to remove the speed selector/pitch control button.
5. Remove the setscrews ㉕ in Fig. 5 to remove the start/stop button.

Note: The setscrews of the start/stop button and the speed selector/pitch control button are adjusted so that the screw tips slightly touch the buttons (to attain smooth switching). If further adjustment is needed, refer to Fig. 5 (A) and (B).

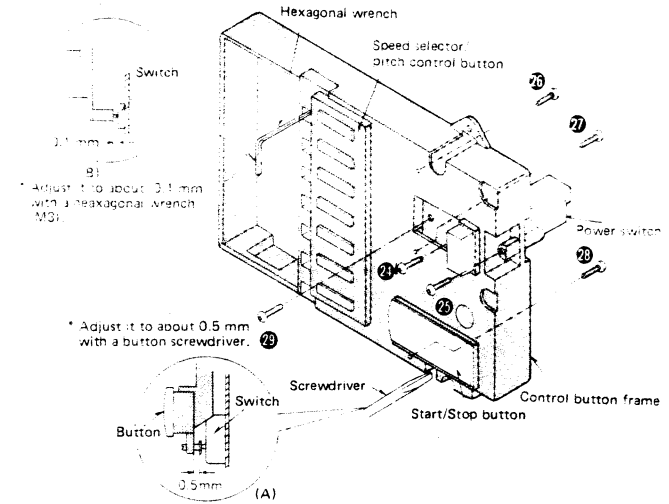

Fig. 5

• **How to remove the constant voltage and operation circuit P.C.B.**

1. Remove the cabinet and front panel.
2. Pull out 4 connectors (CN2, CN3, CN202 and CN403). (Fig. 6)
3. Remove the 3 setscrews (Fig. 6 : ㉖ ~ ㉘) of the printed circuit board and remove the board in the direction of the arrow A.

• **How to remove the control circuit P.C.B.**

1. Remove the cabinet and front panel.
2. Pull out 6 connectors (CN1, CN2, CN3, CN401, CN202 and CN204). (Fig. 6)
3. Remove the 3 setscrews (Fig. 6 : ㉙, ㉚, ㉛) of the printed board and remove the board in the direction of the arrow A.

• **How to remove the driving circuit P.C.B.**

1. Remove the cabinet and front panel.
2. Pull out 5 connectors (CN1, CN2, CN401, CN202 and CN201). (Fig. 6)
3. Cut off the lead wire clumper of CN203.
4. Remove the 4 setscrews (Fig. 6 : ㉜, ㉝, ㉞, ㉟) of the printed board and remove the board in the direction of the arrow A.

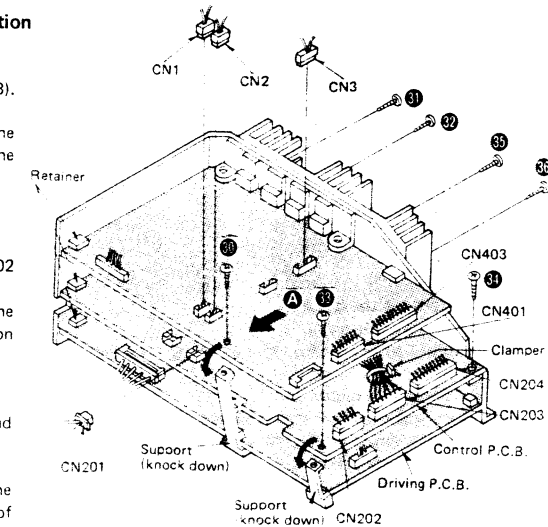

* To mount each P.C.B., fit it in the P.C.B. retainer and support rod groove.

Fig. 6

• How to remove the power fuse P.C.B.

1. Remove the cabinet.
2. Remove the 2 setscrews (Fig. 7 : 47, 48) of the printed circuit board.

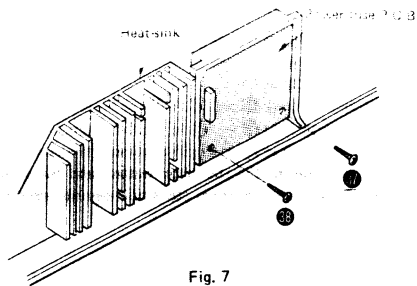

Fig. 7

2. Turntable unit

• How to remove the turntable platter

1. Turn off the power switch. (Check that the brake solenoid is "OFF".)
2. Turn the platter lock ring counterclockwise by using the wrench (attached) to remove the ring. (Fig. 8)
3. Completely fasten the platter mounting handle (attached) into the screw holes (2 portions). (Fig. 8)
4. Slowly lift up the turntable platter, holding the platter mounting handle.

Note: The platter weighs 10 kg. Take care not to drop it when lifting.

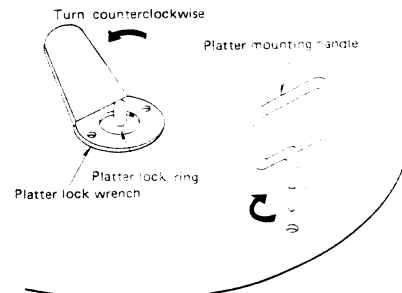

Fig. 8

• How to remove the bottom cover

1. Remove the turntable platter.
2. Place a proper base under the panel on either side so that external forces will not be applied to the center spindle. (Fig. 9)
3. Remove the 15 setscrews (Fig. 10 : 39) of the bottom cover.

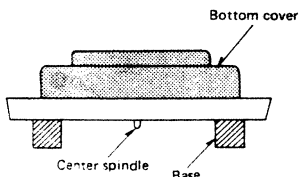

Fig. 9

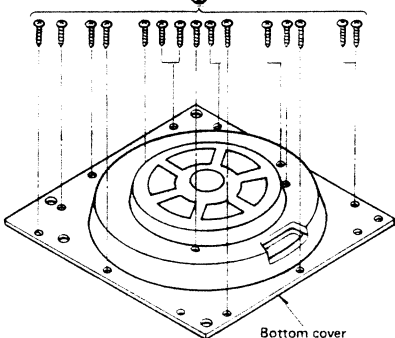

Fig. 10

• How to remove the brake

1. Remove the turntable platter.
2. Remove the 7 setscrews (Fig. 11 : 40 ~ 46) of the panel cover.
3. Remove the housing rubber.
4. Pull out the lead connector of the solenoid. (Fig. 12)
5. Remove the 4 setscrews (Fig. 12 : 47 ~ 50) of the brake and lift up the brake.
6. When removing the brake band, remove 2 setscrews (Fig. 12 : 51, 52).

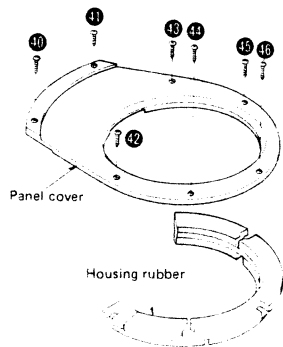

Fig. 11

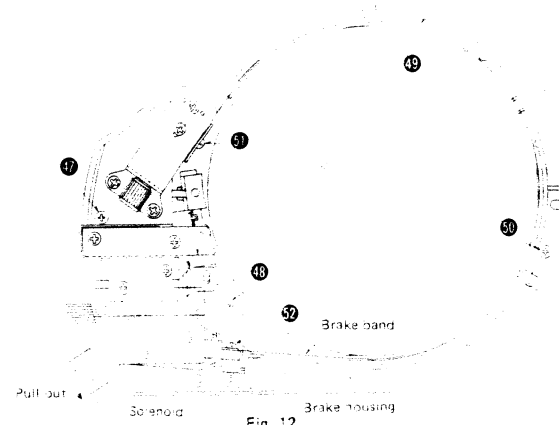

Fig. 12

• How to remove the motor

1. Remove the brake.
2. Remove the 4 setscrews (Fig. 13 : 53 ~ 56) of the stator frame. (Use the hexagonal wrench (M4)).
3. Pull out the connector and lift it up to remove the motor.

Notes: 1. When inserting the connector, remove the bottom cover beforehand. (See Fig. 14)

2. The DC resistance of armature drive coil is about 22Ω. (There are 3 coils - 1st (Green), 2nd (Red), and 3rd (Blue). The difference in resistance between the layers is less than 1Ω.)

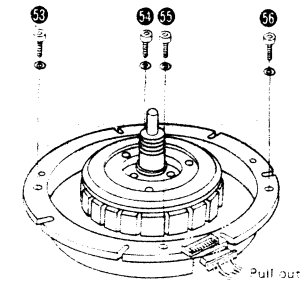

Fig. 13

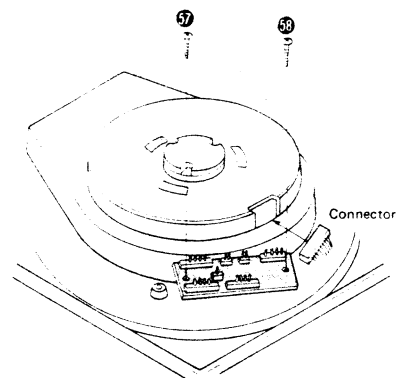

Fig. 14

• How to remove the connection P.C.B.

1. Remove the bottom cover.
2. Remove the 2 setscrews (Fig. 14 : 57, 58) of the printed board to remove the board.

• How to remove the strobe LED P.C.B.

1. Remove the bottom cover.
2. Shift the claws which fasten the printed circuit board in the direction of the arrow to remove the board. (Fig. 15)

• How to remove the speed selector P.C.B.

1. Remove the bottom cover.
2. Remove the 5 setscrews (Fig. 15 : 59 ~ 63) of the speed selector P.C.B.
3. Remove the setscrews 64, 65 in Fig. 15 to remove the start/stop switch.
4. Remove the 2 setscrews (Fig. 16 : 66, 67) of the start/stop button.
5. Remove the 3 setscrews (Fig. 16 : 68 ~ 70) of the speed selector button.
6. Shift the claws (2 portions) in the direction of the arrow to remove the board.

* For the speed selector and start/stop button screw adjustment refer to Fig. 5 on page 5.

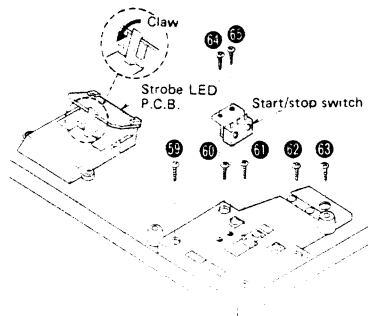

Fig. 15

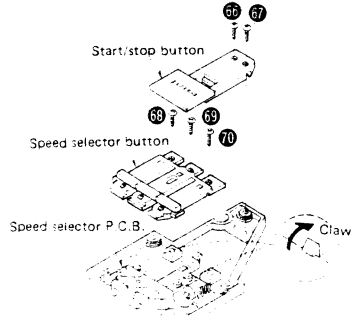

Fig. 16

■ HOW TO CHECK THE PRINTED CIRCUIT BOARD

● Operation circuit P.C.B.

1. Remove the cabinet.
2. Remove the 4 setscrews (Fig. 17 : ㉗ ~ ㉙) of the front panel.
3. Cut off the clumper, remove the front panel in the direction of the arrow and check the printed board from the back side.
4. When replacing the parts of the P.C.B., remove the P.C.B. (Refer to "How to remove the operation circuit P.C.B.")

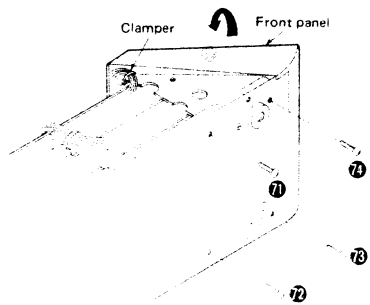

Fig. 17

● Constant voltage and operation circuit P.C.B.

1. Remove the cabinet and front panel.
2. Check from above the printed circuit board.
3. When replacing the parts of the printed circuit board, remove the P.C.B. (Refer to "How to remove the constant voltage and operation circuit P.C.B.")

Note: Do not check the conduction of the printed board with the heat-sink removed. (Keeping it energized for a long period of time may damage the parts.)

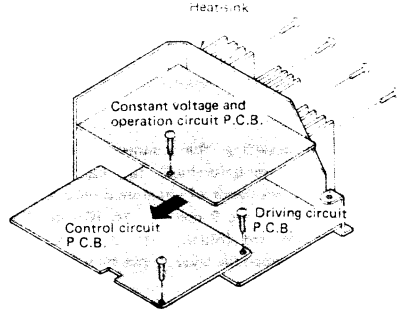

Fig. 18

● Control circuit P.C.B.

1. Remove the cabinet and front panel.
2. Remove the printed circuit board. (Refer to "How to remove the control circuit P.C.B.")
3. Connect the connector and check the conduction.

● Driving circuit P.C.B.

1. Remove the cabinet and front panel.
2. Remove the 3 setscrews (Fig. 19 : ㉛ ~ ㉝) of the heat-sink and 2 setscrews (Fig. 19 : ㉞, ㉟) of the printed board support, shift down the board in the direction of the arrow and check it from the back side. (Fig. 20)
3. When replacing the parts of the printed board, remove either the driving circuit P.C.B. (Refer to "How to remove the driving circuit P.C.B.") or the control circuit P.C.B. (Refer to "How to remove the control circuit P.C.B.")

Note: Do not check the conduction of the driving circuit P.C.B. with the heat-sink removed. (If it is energized for a long period of time, the protection circuit will operate to stop the turntable. It may also damage the parts.)

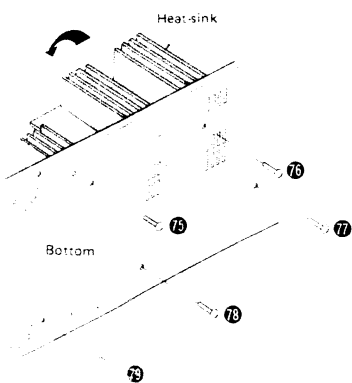

Fig. 19

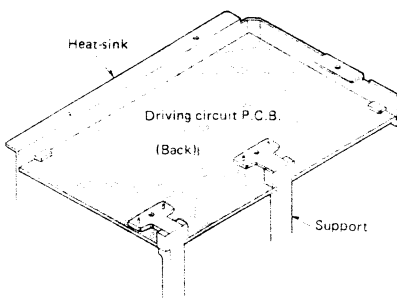

Fig. 20

■ MEASUREMENTS AND ADJUSTMENT

● Instruments used and settings

1. DC voltmeter
2. Oscilloscope
3. DC Power Supply.
4. Set the pitch control to 0%.

Item	Preparations	Adjusting Parts	Adjusting Method								
Constant Voltage	<ol style="list-style-type: none"> 1. Pull out the connectors CN1, CN2 and CN3. 2. Connect the DC voltmeter to either CN1 terminal ㉓ (+) and BT1 terminal ㉑ (-) or the negative side of C3. 3. Turn the power switch "on". 	VR1	1. Adjust VR1 so that the output voltage is 31.8V.								
	<ol style="list-style-type: none"> 1. Pull out the connectors CN1, CN2 and CN3. 2. Connect the DC voltmeter to either CN1 terminal 1 (+) and BT1 terminal 3 (-) or the negative side of C3. 3. Turn the power switch "on". 	VR2	1. Adjust VR2 so that the output voltage is -31.8V.								
Crystal Oscillation	<ol style="list-style-type: none"> 1. Connect the oscilloscope to IC202 pin 7 and ground terminal. 2. Turn the power switch "on". 	C211	1. Adjust C211 so that the cycle is 3.81 μsec. (262.08 kHz).								
VS Voltage	<ol style="list-style-type: none"> 1. Connect the DC voltmeter to CN206 terminal ㉑ (+) and CN206 terminal ㉒ (-). 2. Turn the power switch "on" and set the speed selector to "33 r.p.m." 	VR201	1. Adjust VR201 so that the output voltage is 2.1V.								
RS Current	<ol style="list-style-type: none"> 1. Connect the DC voltmeter to CN206 terminal ㉓ (+) and CN206 terminal ㉔ (-). 2. Turn the power switch "on" and set the speed selector to "33 r.p.m." 3. Press the start button. 	VR206	1. Adjust VR206 so that the output voltage is 0V.								
Synchronizing position	<ol style="list-style-type: none"> 1. Connect the oscilloscope to CN206 terminal ㉒ (+) and CN206 terminal ㉑ (-). 2. Turn the power switch "on" and press the start button. 	VR203 (33 r.p.m.) VR204 (45 r.p.m.) VR205 (78 r.p.m.)	<ol style="list-style-type: none"> 1. Switch over the speed selector to "33", "45" and "78" and adjust VR203, VR204 and VR205 so that the time T is as in the table below: <table border="1"> <thead> <tr> <th>Speed</th> <th>T</th> </tr> </thead> <tbody> <tr> <td>33</td> <td>8.5msec.</td> </tr> <tr> <td>45</td> <td>6.6msec.</td> </tr> <tr> <td>78</td> <td>3.8msec.</td> </tr> </tbody> </table>	Speed	T	33	8.5msec.	45	6.6msec.	78	3.8msec.
Speed	T										
33	8.5msec.										
45	6.6msec.										
78	3.8msec.										
Brake (electric)	<ol style="list-style-type: none"> 1. Pull out CN202 connector. (With mechanical brake released) 2. Turn the power switch "on" and set the speed selector to "33 r.p.m." 3. Press the start button. 	VR202	<ol style="list-style-type: none"> 1. Press the stop button. 2. Adjust VR202 so that the range of angle for stop of the rotation is 90° ~ 180°. 								
Offset voltage	<ol style="list-style-type: none"> 1. Apply 40mV between CN203 terminals 2. and 3. by the DC power supply. 2. Connect the DC voltmeter between CN102 terminals ㉑ and 4. 3. Turn the power switch "on" and press the start button. 	VR101	1. Adjust VR101 so that the output voltage is 10mV.								
Middle voltage	<ol style="list-style-type: none"> 1. Connect the DC voltmeter between CN102 terminals ㉑ and 2. 2. Turn the power switch "on" and press the start button. 	VR102	1. Adjust VR102 so that the output voltage is 0V.								

• Adjusting method without DC power supply for offset voltage adjustment

1. Solder 3 resistors to the driving circuit P.C.B. (Refer to Fig. 21)
2. Pull out CN203 connector. (Control circuit P.C.B.)
3. Connect CN203 terminal ⑤ to BT102 terminal ⑤ and CN203 terminal ④ to BT102 terminal ④, using lead wire with clip, etc.
4. Connect the DC voltmeter between CN102 terminals ③ and ④.
5. Turn the power switch "on" and press the start button.
6. Adjust VR101 so that the DC voltmeter reading is 10mV.
7. Remove the 3 resistors and lead wire.

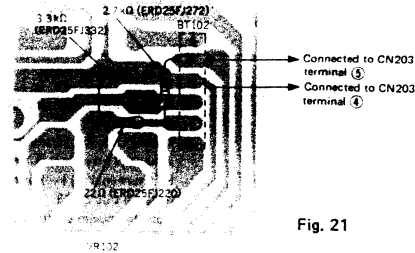

Fig. 21

• Adjustment of the mechanical brake

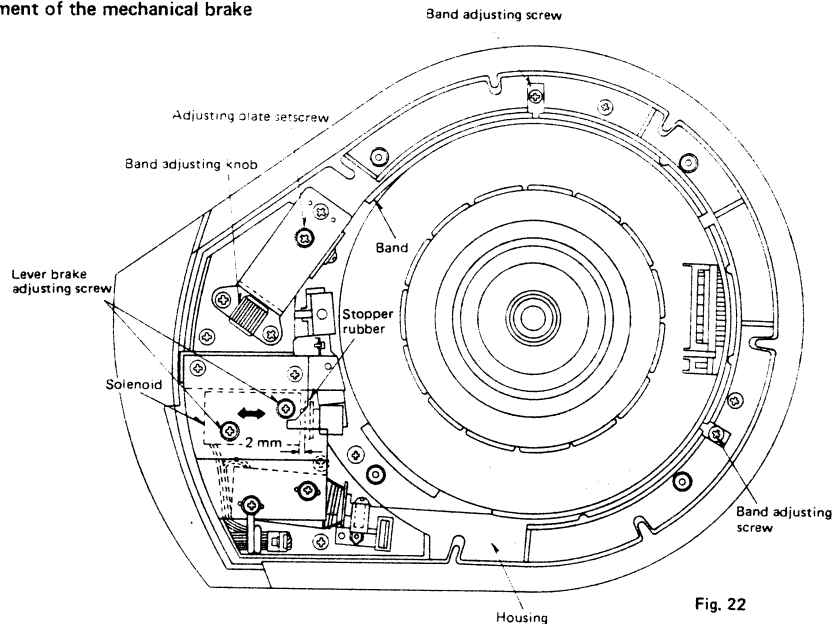

Fig. 22

1. Adjustment of the lever brake

1. Remove the turntable platter.
2. Loosen the lever brake adjusting screw.
3. Shift the solenoid right and left so that the clearance between the solenoid and stopper rubber is about 2 mm.
4. Tighten the lever brake adjusting screw.
5. Mount the turntable and check to see that the turntable does not move with the power switch set to "off".

2. Adjustment of the band brake

• Check of the band position

1. Remove the turntable.
2. The inner periphery of the band should match the inner periphery of the housing.
3. If they are deflected, adjust it by loosening the adjusting screws at two portions.

• Check of the brake angle

1. Turn the turntable.
2. Press the stop button and check to see that the range of angle for stop of the rotation is 40° or less.
3. If the stopping angle is over 40°, adjust the electric brake beforehand. (Refer to page 9.)
4. Next, loosen the adjusting plate setscrew and turn the adjusting knob so that the angle is 40° or less.

• Adjustment points

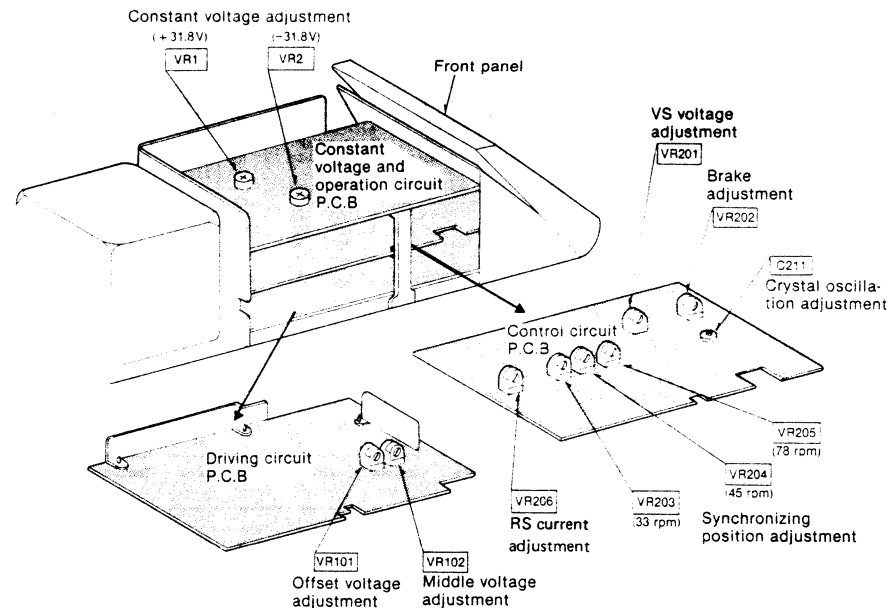

■ RESISTORS & CAPACITORS

- Notes:**
1. Part numbers are indicated on most mechanical parts. Please use this part number for parts orders.
 2. Important safety notice: Components identified by Δ mark have special characteristics important for safety. When replacing any of these components use only, manufacturer's specified parts.
 3. Bracketed indications in Ref. No. columns specify the area. Parts without these indications can be used for all areas.
 4. The "S" mark is service standard parts and may differ from production parts.
 5. Unless otherwise specified. All resistors are in OHMS (Ω) K = 100 Ω , M = 1000k Ω All capacitors are in MICROFARADS (μ F) P = μ MF

Numbering System of Resistor

Example

ERD	25	F	J	101
Type	Wattage	Shape	Tolerance	Value

Resistor Type	Wattage	Tolerance
ERD : Carbon	25	1/4W J : \pm 5%
ERG : Metal Oxide	50	1/2W
ERX : Metal Film	1	1W
	2	2W

Ref. No.	Part No.	Value	Ref. No.	Part No.	Value	Ref. No.	Part No.	Value	Ref. No.	Part No.	Value
RESISTORS											
R1	S ERD25FJ102	1k	R109	S ERD25TJ393	39k	R135	S ERD25FJ103	10k	R164	S ERD25FJ332	3.3k
R2	S ERD25FJ332	3.3k	R110	S ERD25TJ223	22k	R137	S ERG2ANJ150	15	R201	S ERD25FJ472	4.7k
R3	S ERD25FJ152	1.5k	R111	S ERD25FJ562	5.6k	R139	S ERG2ANJ150	15	R202	S ERD25FJ471	470
R4	S ERD25FJ332	3.3k	R113	S ERD25FJ332	3.3k	R140	Δ ERD2FCG101	100	R203	S ERD25FJ222	2.2k
R5	S ERD25TJ273	27k	R114	S ERD25TJ183	18k	R141	142 S ERD25FJ151	150	R204	S ERD25FJ563	56k
R6	S ERD25FJ682	6.8k	R115	S ERD25FJ471	47k	R143	144 S ERD25FJ151	150	R205-206	S ERD25TJ123	12k
R10	S ERD25FJ103	10k	R116	S ERD25FJ102	1k	R145	146 S ERD25FJ151	150	R207	S ERD25TJ123	12k
R11	S ERD25FJ102	1k	R117	S ERD25FJ562	5.6k	R147	S ERX2ANJR47	0.47	R208	S ERD25TJ473	47k
R12, 13	S ERD25FJ332	3.3k	R118	S ERD25FJ471	47k	R148	S ERG2ANJ271	27k	R209	S ERD25FJ103	10k
R17	S ERD25FJ103	10k	R119	S ERD25FJ220	22	R149	S ERD25FJ103	10k	R210	S ERD25TJ223	22k
R18	S ERD25FJ560	56	R120	S ERD25FJ472	4.7k	R150	151 S ERD25TJ393	39k	R211	S ERD25FJ332	3.3k
R19	S ERD25FJ182	1.8k	R121	S ERD25FJ103	10k	R152	S ERD25TJ474	47k	R212	S ERD25TJ223	22k
R20	S ERD25FJ122	1.2k	R122	S ERD25FJ222	2.2k	R153	S ERD25TJ104	100k	R213	S ERD25FJ822	8.2k
R21	S ERX2ANJR68	0.68	R123	S ERD25FJ470	47	R154	S ERD25FJ101	100	R214	S ERD25FJ153	15k
R103	S ERD25FJ102	1k	R124, 125	S ERD25FJ472	4.7k	R155	S ERD25FJ102	1k	R215	S ERD25FJ472	4.7k
R104	S ERD25TJ474	47k	R126	S ERD25FJ222	2.2k	R156	S ERD25TJ473	47k	R216	S ERD25TJ183	18k
R105	S ERD25FJ472	4.7k	R127, 128	S ERD25FJ103	10k	R157	S ERD25FJ103	10k	R217	S ERD25TJ333	33k
R106	S ERD25TJ563	56k	R129	S ERD25TJ153	15k	R158	S ERD25TJ564	56k	R218	S ERD25TJ333	33k
R107	S ERD25FJ101	100	R130	S ERD25FJ102	1k	R159, 160	S ERD25FJ113	11k	R219	S ERD25TJ333	33k
R108	S ERD25TJ473	47k	R132, 133	S ERD25FJ103	10k	R161	S ERD25FJ472	4.7k	R220	S ERD25TJ123	12k
			R134	S ERD25FJ103	10k	R162	S ERD25FJ471	4.7k	R221	S ERD25TJ123	12k
			R135, 136	S ERD25FJ103	10k	R163	S ERD25FJ102	1k	R222	S ERD25TJ123	12k

SP-10MK3

Ref. No.	Part No.	Value	Ref. No.	Part No.	Value	Ref. No.	Part No.	Value	Ref. No.	Part No.	Value
R202	\$ ERD25F122	1.2k	R303	\$ ERD25F147	1.5k	R433	\$ ERD25F1331	33k	R415	\$ ERD25F163	15k
R203	\$ ERD25F127	1.2k	R304	\$ ERD25F143	1.4k	R434	\$ ERD25F1331	33k	R417	\$ ERD25F163	15k
R234	\$ ERD25F102	1k	R305	\$ ERD25F120	12k	R435	\$ ERD25F1331	33k	R419	\$ ERD25F163	15k
R235	\$ ERD25F093	9k	R306	\$ ERD25F162	1.6k	R436	\$ ERD25F1331	33k	R420	\$ ERD25F182	1.8k
R236	\$ ERD25T104	100k	R308	\$ ERD25F102	1k	R431	\$ ERD25F331	33k	R421	\$ ERD25F101	100
R237	\$ ERD25T683	68k	R309	\$ ERD25F332	3.3k	R433	\$ ERD25F331	33k	R422	\$ ERD25F333	33k
R238	\$ ERD25F1471	47k	R310	\$ ERD25F1472	4.7k	R444	\$ ERD25F360	60	R423	\$ ERD25F103	10k
R239	\$ ERD25F182	1.8k	R311	\$ ERD25T1563	56k	R360	\$ ERD25T1473	47k	R425	\$ ERD25F103	10k
R251	\$ ERD25T1273	27k	R321	\$ ERD25F1680	68	R361	\$ ERD25F101	100	R427	\$ ERD25T333	33k
R252	\$ ERD25F152	1.5k	R322	\$ ERD25F122	1.2k	R362	\$ ERD25F091	90	R428	\$ ERD25T153	15k
R253	\$ ERD25F102	1k	R323	\$ ERD25F152	1.5k	R401	\$ ERD25F103	10k	R430	\$ ERD25F162	5.6k
R254	\$ ERD25F1471	47k	R325	\$ ERD25F152	1.5k	R403	\$ ERD25F103	10k	R431	\$ ERD25T104	100k
R255	\$ ERD25F180	18	R326	\$ ERD25F221	22k	R404	\$ ERD25T153	15k	R501	\$ ERD25F162	5.6k
R256	\$ ERD25T193	29k	R327	\$ ERD25F162	1.6k	R405	\$ ERD25T153	15k	R506	\$ ERD25F162	5.6k
R257	\$ ERD25F100	10	R329	\$ ERD25F102	1k	R406	\$ ERD25T153	15k	R508	\$ ERD25F162	5.6k
R258	\$ ERD25F162	5.6k	R330	\$ ERD25F172	17k	R407	\$ ERD25T1473	47k	R509	\$ ERD25F162	5.6k
R259	\$ ERD25T223	22k	R331	\$ ERD25F192	19k	R408	\$ ERD25T1473	47k	R510	\$ ERD25F162	5.6k
R260	\$ ERD25F103	1k	R332	\$ ERD25T192	19k	R411	\$ ERD25F103	10k	R511	\$ ERD25F162	5.6k

Numbering System of Capacitor

Example

ECKD	1H	103	Z	F	ECEA	50	M	R47	R
Type	Voltage	Value	Tolerance	Peculiarity	Type	Voltage	Peculiarity use	Value	Special use

Capacitor Type		Voltage		Tolerance			
		ECEA Type	Others				
ECEA	: Electrolytic	1A	: 10V	1H	: 500V DC	J	: ± 5%
ECEA	: N : Non Polar Electrolytic	1C	: 16V	2H	: 500V DC	K	: ± 10%
ECCD	: Ceramic	1E	: 25V	05	: 50V DC	M	: ± 20%
ECKD	: Ceramic	1V	: 35V	1	: 125V DC	Z	: + 80%, - -20%
ECQM	: Polyester	1H	: 50V	1A	: 125V AC	P	: + 100%, - -0%
ECQF	: Polyester	1J	: 63V				
ECQV	: Polyester	50	: 50V				
ECEB	: Electrolytic	25	: 25V				
ECQU	: Polyester	2A	: 100V				

Ref. No.	Part No.	Value	Ref. No.	Part No.	Value	Ref. No.	Part No.	Value	Ref. No.	Part No.	Value
CAPACITORS											
C10	\$ ECQM1H233J2	0.022	C108	\$ ECEA1H104J2	0.1	C206	\$ ECEA1H5330	0.005	C208	\$ ECEA1H5100	0.01
C11	\$ ECEA1H2470	47	C109	\$ ECEA1H5331	0.01	C207	\$ ECEA6021	0.005	C209	\$ ECEA1H5100	0.01
C12	\$ ECEA1H5470	47	C110	\$ ECQM1H133J2	0.01	C208	\$ ECQM1H331K	0.005	C210	\$ ECEA1H5471	47k
C13	\$ ECEA1H5102	1000	C111	\$ ECQM1H104J2	0.1	C209	\$ ECQM1H221K	0.005	C211	\$ ECEA1H5221	22k
C14	\$ ECEA1H5470	47	C112	\$ ECQM1H223J2	0.022	C210	\$ ECQM1H220K	0.02	C212	\$ ECQM1H333J2	0.0033
C15	\$ ECEA1H5470	47	C113	\$ ECQM1H333J2	0.01	C211	\$ ECQV95154J2	0.1	C213	\$ ECEA1H5331	0.0033
C16	\$ ECEA1H5470	47	C114	\$ ECEA1H3330	0.01	C212	\$ ECQM1H124J2	0.1	C214	\$ ECEA1H5100	0.01
C17	\$ ECEA1H5470	47	C115	\$ ECQM1H104J2	0.1	C213	\$ ECQM1H62J2	0.0056	C215	\$ ECEA1H5100	0.01
C18	\$ ECEA1H5470	47	C116	\$ ECEA1H4R7S	0.022	C214	\$ ECQM1H103J2	0.01	C216	\$ ECEA5021	0.01
C19	\$ ECKD1H223PF	0.022	C117	\$ ECEA1H4R7S	0.022	C215	\$ ECQM1H103J2	0.01	C217	\$ ECEA1H5100	0.01
C20	\$ ECEB1E5102	1000	C118	\$ ECEA1E5101	100	C216	\$ ECQV05154J2	0.15	C218	\$ ECEA1H5100	0.01
C21	\$ ECQM1H473J2	0.047	C119	\$ ECQM1H103J2	0.01	C217	\$ ECQM1H154J2	0.15	C219	\$ ECEA1H5100	0.01
C22	\$ ECEA1H3331	0.0033	C120	\$ ECEA1H5100	10	C218	\$ ECEA1H1010S	0.002	C220	\$ ECQM1H103J2	0.01
C23	\$ ECQM1H473J2	0.047	C121	\$ ECQM1H103J2	0.01	C219	\$ ECQM1H104J2	0.1	C221	\$ ECQM1H103J2	0.01
C24	\$ ECEA1H5470	47	C122	\$ ECQM1H103J2	0.01	C220	\$ ECQM1H103J2	0.01	C222	\$ ECQM1H102K	0.001
C25	\$ ECEA1H5102	1000	C123	\$ ECQM1H103J2	0.01	C221	\$ ECEA1H5101	100	C223	\$ ECKD1H221K	0.022
C26	\$ ECEA1H5470	47	C124	\$ ECQM1H103J2	0.01	C222	\$ ECQM1H104J2	0.1	C224	\$ ECEA1H5101	100
C27	\$ ECEA1H5470	47	C125	\$ ECQM1H103J2	0.01	C223	\$ ECEA1H5470	47	C225	\$ ECEA1H5101	100
C28	\$ ECEA1H5470	47	C126	\$ ECQM1H103J2	0.01	C224	\$ ECQM1H222J2	0.0022	C226	\$ ECEA1H5101	100
C29	\$ ECEA1H5470	47	C127	\$ ECQM1H103J2	0.01	C225	\$ ECEA1H5101	100	C227	\$ ECQM1H222J2	0.0022
C30	\$ ECEA1H5470	47	C128	\$ ECQM1H103J2	0.01	C226	\$ ECQM1H222J2	0.0022	C228	\$ ECQM1H222J2	0.0022
C31	\$ ECEA1H5470	47	C129	\$ ECQM1H103J2	0.01	C227	\$ ECQM1H222J2	0.0022	C229	\$ ECQM1H222J2	0.0022
C32	\$ ECEA1H5470	47	C130	\$ ECQM1H103J2	0.01	C228	\$ ECQM1H222J2	0.0022	C230	\$ ECQM1H222J2	0.0022
C33	\$ ECEA1H5470	47	C131	\$ ECQM1H103J2	0.01	C229	\$ ECQM1H222J2	0.0022	C231	\$ ECQM1H222J2	0.0022
C34	\$ ECEA1H5470	47	C132	\$ ECQM1H103J2	0.01	C230	\$ ECQM1H222J2	0.0022	C232	\$ ECQM1H222J2	0.0022
C35	\$ ECEA1H5470	47	C133	\$ ECQM1H103J2	0.01	C231	\$ ECQM1H222J2	0.0022	C233	\$ ECQM1H222J2	0.0022
C36	\$ ECEA1H5470	47	C134	\$ ECQM1H103J2	0.01	C232	\$ ECQM1H222J2	0.0022	C234	\$ ECQM1H222J2	0.0022
C37	\$ ECEA1H5470	47	C135	\$ ECQM1H103J2	0.01	C233	\$ ECQM1H222J2	0.0022	C235	\$ ECQM1H222J2	0.0022
C38	\$ ECEA1H5470	47	C136	\$ ECQM1H103J2	0.01	C234	\$ ECQM1H222J2	0.0022	C236	\$ ECQM1H222J2	0.0022
C39	\$ ECEA1H5470	47	C137	\$ ECQM1H103J2	0.01	C235	\$ ECQM1H222J2	0.0022	C237	\$ ECQM1H222J2	0.0022
C40	\$ ECEA1H5470	47	C138	\$ ECQM1H103J2	0.01	C236	\$ ECQM1H222J2	0.0022	C238	\$ ECQM1H222J2	0.0022
C41	\$ ECEA1H5470	47	C139	\$ ECQM1H103J2	0.01	C237	\$ ECQM1H222J2	0.0022	C239	\$ ECQM1H222J2	0.0022
C42	\$ ECEA1H5470	47	C140	\$ ECQM1H103J2	0.01	C238	\$ ECQM1H222J2	0.0022	C240	\$ ECQM1H222J2	0.0022
C43	\$ ECEA1H5470	47	C141	\$ ECQM1H103J2	0.01	C239	\$ ECQM1H222J2	0.0022	C241	\$ ECQM1H222J2	0.0022
C44	\$ ECEA1H5470	47	C142	\$ ECQM1H103J2	0.01	C240	\$ ECQM1H222J2	0.0022	C242	\$ ECQM1H222J2	0.0022
C45	\$ ECEA1H5470	47	C143	\$ ECQM1H103J2	0.01	C241	\$ ECQM1H222J2	0.0022	C243	\$ ECQM1H222J2	0.0022
C46	\$ ECEA1H5470	47	C144	\$ ECQM1H103J2	0.01	C242	\$ ECQM1H222J2	0.0022	C244	\$ ECQM1H222J2	0.0022
C47	\$ ECEA1H5470	47	C145	\$ ECQM1H103J2	0.01	C243	\$ ECQM1H222J2	0.0022	C245	\$ ECQM1H222J2	0.0022
C48	\$ ECEA1H5470	47	C146	\$ ECQM1H103J2	0.01	C244	\$ ECQM1H222J2	0.0022	C246	\$ ECQM1H222J2	0.0022
C49	\$ ECEA1H5470	47	C147	\$ ECQM1H103J2	0.01	C245	\$ ECQM1H222J2	0.0022	C247	\$ ECQM1H222J2	0.0022
C50	\$ ECEA1H5470	47	C148	\$ ECQM1H103J2	0.01	C246	\$ ECQM1H222J2	0.0022	C248	\$ ECQM1H222J2	0.0022
C51	\$ ECEA1H5470	47	C149	\$ ECQM1H103J2	0.01	C247	\$ ECQM1H222J2	0.0022	C249	\$ ECQM1H222J2	0.0022
C52	\$ ECEA1H5470	47	C150	\$ ECQM1H103J2	0.01	C248	\$ ECQM1H222J2	0.0022	C250	\$ ECQM1H222J2	0.0022
C53	\$ ECEA1H5470	47	C151	\$ ECQM1H103J2	0.01	C249	\$ ECQM1H222J2	0.0022	C251	\$ ECQM1H222J2	0.0022
C54	\$ ECEA1H5470	47	C152	\$ ECQM1H103J2	0.01	C250	\$ ECQM1H222J2	0.0022	C252	\$ ECQM1H222J2	0.0022
C55	\$ ECEA1H5470	47	C153	\$ ECQM1H103J2	0.01	C251	\$ ECQM1H222J2	0.0022	C253	\$ ECQM1H222J2	0.0022
C56	\$ ECEA1H5470	47	C154	\$ ECQM1H103J2	0.01	C252	\$ ECQM1H222J2	0.0022	C254	\$ ECQM1H222J2	0.0022
C57	\$ ECEA1H5470	47	C155	\$ ECQM1H103J2	0.01	C253	\$ ECQM1H222J2	0.0022	C255	\$ ECQM1H222J2	0.0022
C58	\$ ECEA1H5470	47	C156	\$ ECQM1H103J2	0.01	C254	\$ ECQM1H222J2	0.0022	C256	\$ ECQM1H222J2	0.0022
C59	\$ ECEA1H5470	47	C157	\$ ECQM1H103J2	0.01	C255	\$ ECQM1H222J2	0.0022	C257	\$ ECQM1H222J2	0.0022
C60	\$ ECEA1H5470	47	C158	\$ ECQM1H103J2	0.01	C256	\$ ECQM1H222J2	0.0022	C258	\$ ECQM1H222J2	0.0022
C61	\$ ECEA1H5470	47	C159	\$ ECQM1H103J2	0.01	C257	\$ ECQM1H222J2	0.0022	C259	\$ ECQM1H222J2	0.0022
C62	\$ ECEA1H5470	47	C160	\$ ECQM1H103J2	0.01	C258	\$ ECQM1H222J2	0.0022	C260	\$ ECQM1H222J2	0.0022
C63	\$ ECEA1H5470	47	C161	\$ ECQM1H103J2	0.01	C259	\$ ECQM1H222J2	0.0022	C261	\$ ECQM1H222J2	0.0022
C64	\$ ECEA1H5470	47	C162	\$ ECQM1H103J2	0.01	C260	\$ ECQM1H222J2	0.0022	C262	\$ ECQM1H222J2	0.0022
C65	\$ ECEA1H5470	47	C163	\$ ECQM1H103J2	0.01	C261	\$ ECQM1H222J2	0.0022	C263	\$ ECQM1H222J2	0.0022
C66	\$ ECEA1H5470	47	C164	\$ ECQM1H103J2	0.01	C262	\$ ECQM1H222J2	0.0022	C264	\$ ECQM1H222J2	0.0022
C67	\$ ECEA1H5470	47	C165	\$ ECQM1H103J2	0.01	C263	\$ ECQM1H222J2	0.0022	C265	\$ ECQM1H222J2	0.0022
C68	\$ ECEA1H5470	47	C166	\$ ECQM1H103J2	0.01	C264	\$ ECQM1H222J2	0.0022	C266	\$ ECQM1H222J2	0.0022
C69	\$ ECEA1H5470	47	C167	\$ ECQM1H							

PRINTED CIRCUIT BOARD WIRING CONNECTION DIAGRAM

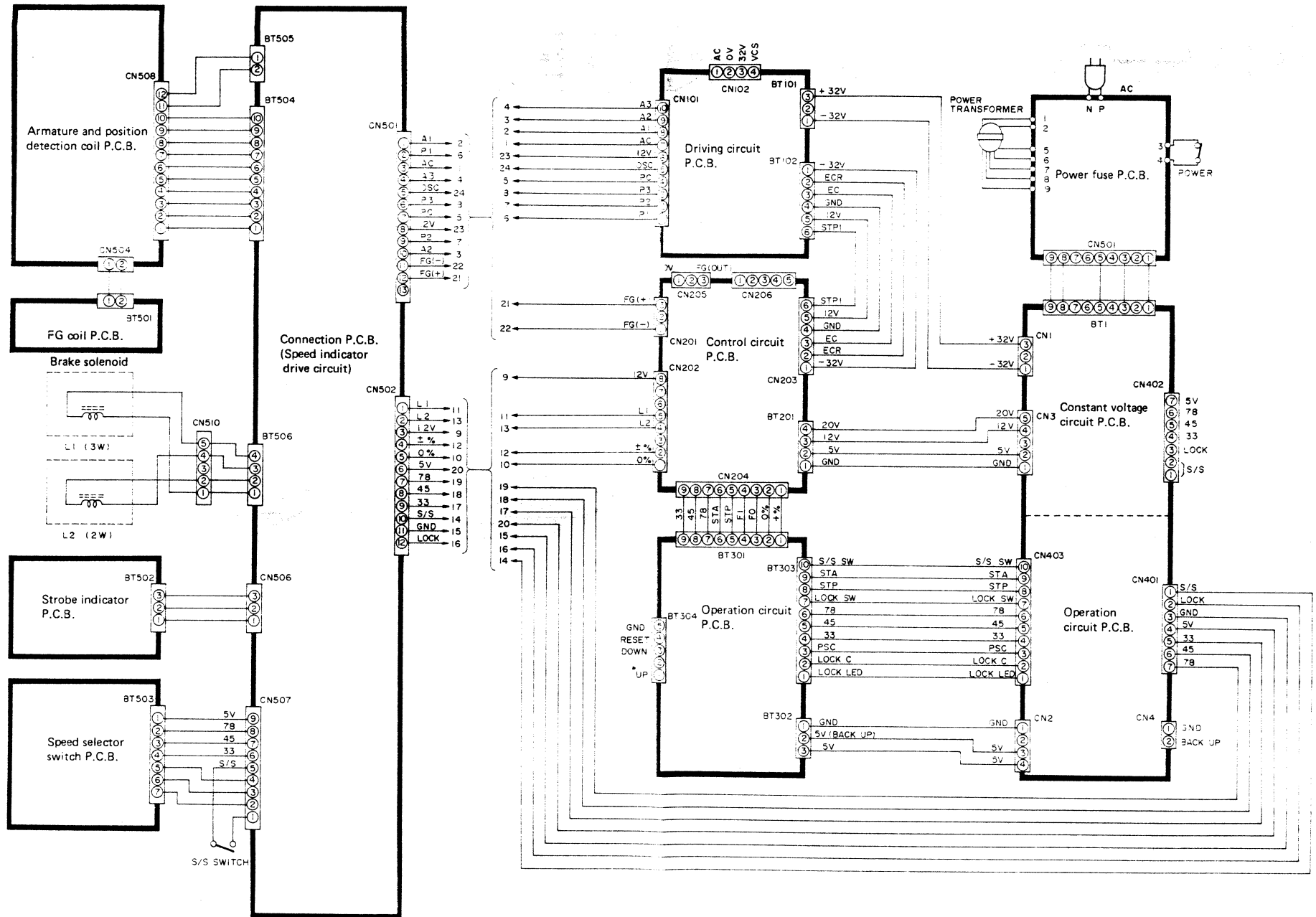

■ BLOCK DIAGRAM

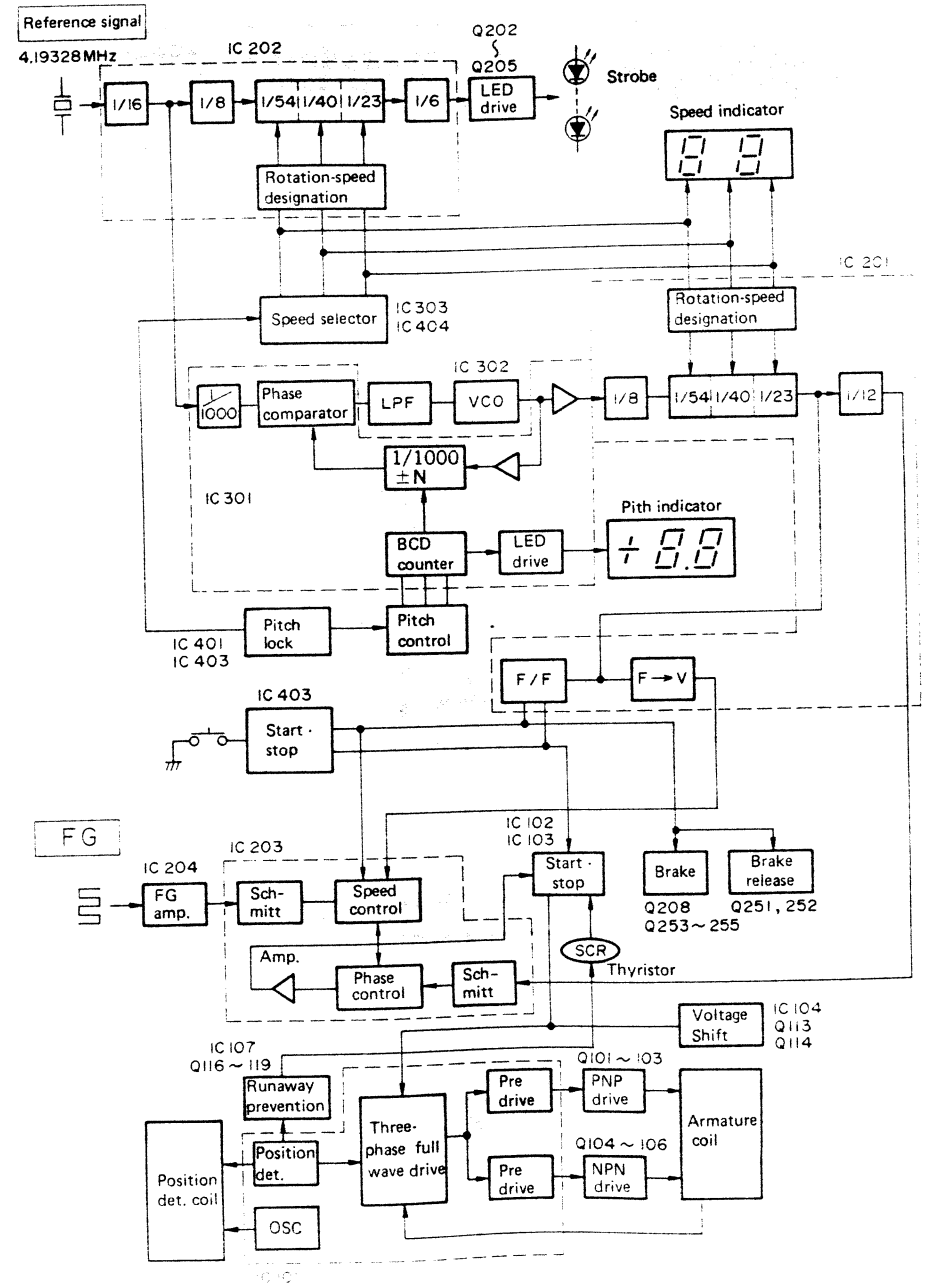

■ **PRINTED CIRCUIT BOARDS**

● **Driving circuit**

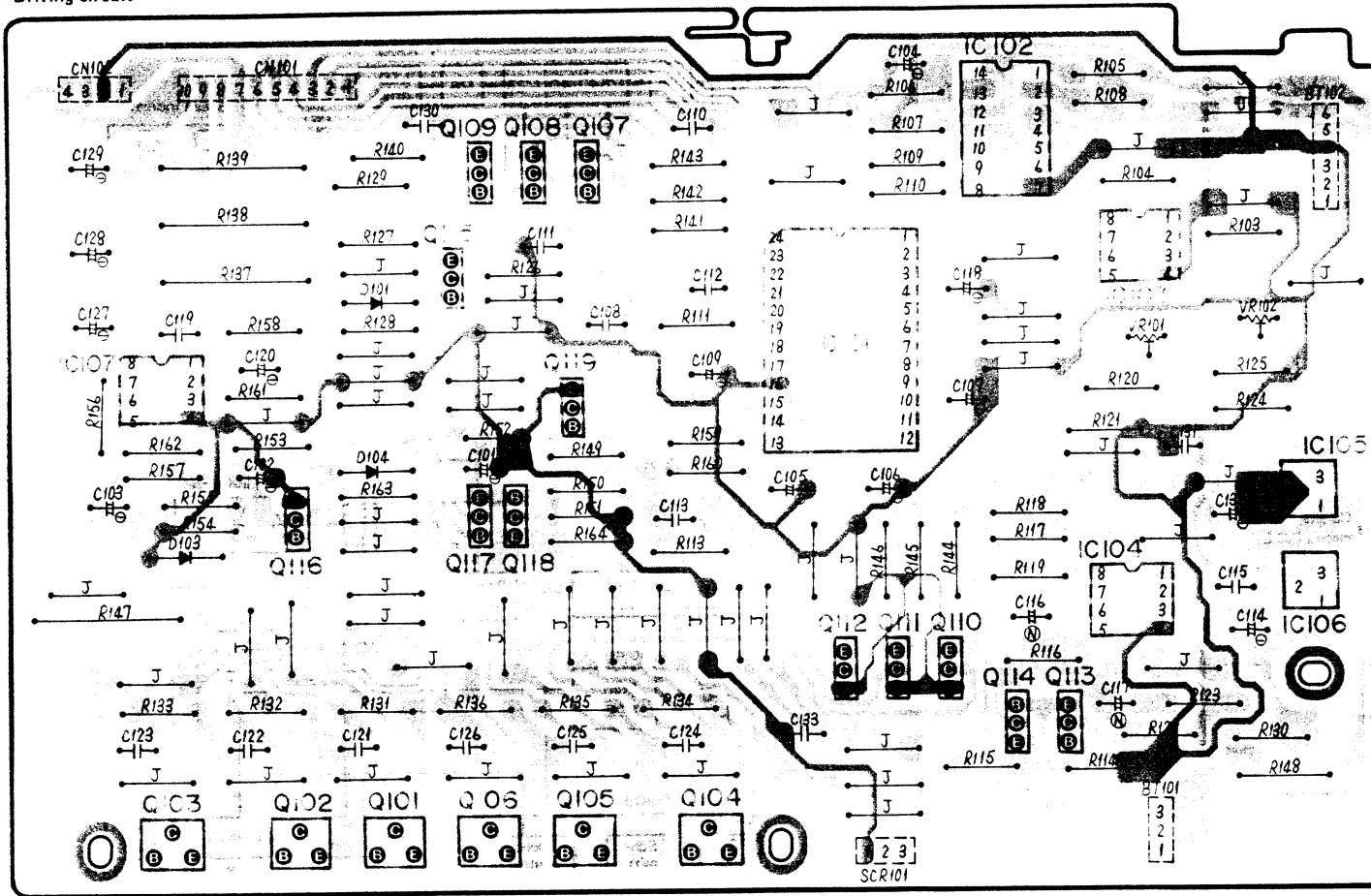

Ground (Earth) lines

● **Block diagram of driving circuit**

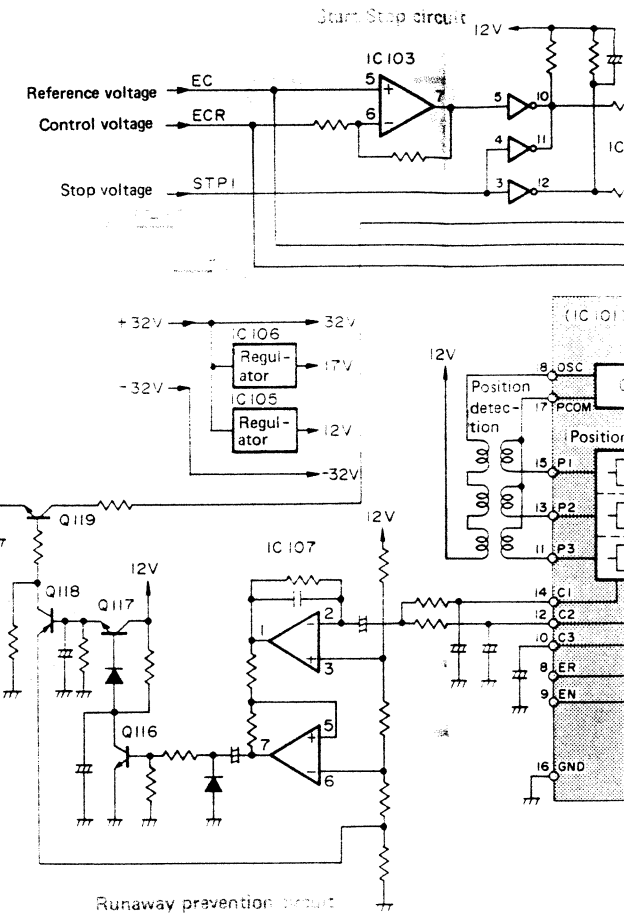

● **Connection board (Speed indicator drive circuit)**

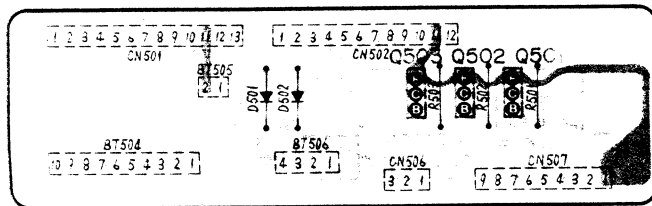

● **Speed selector switch circuit**

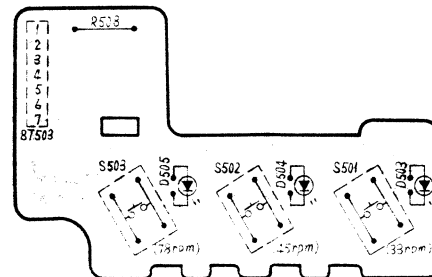

● **Strobe indicator circuit**

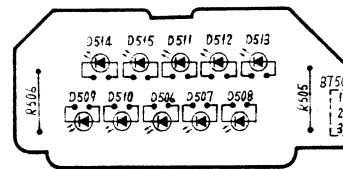

● **Terminal guide of IC and transistors**

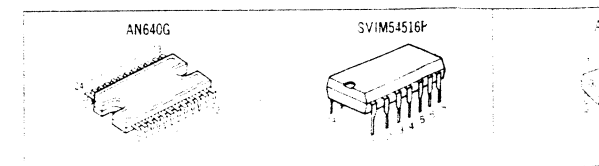

Earth) lines

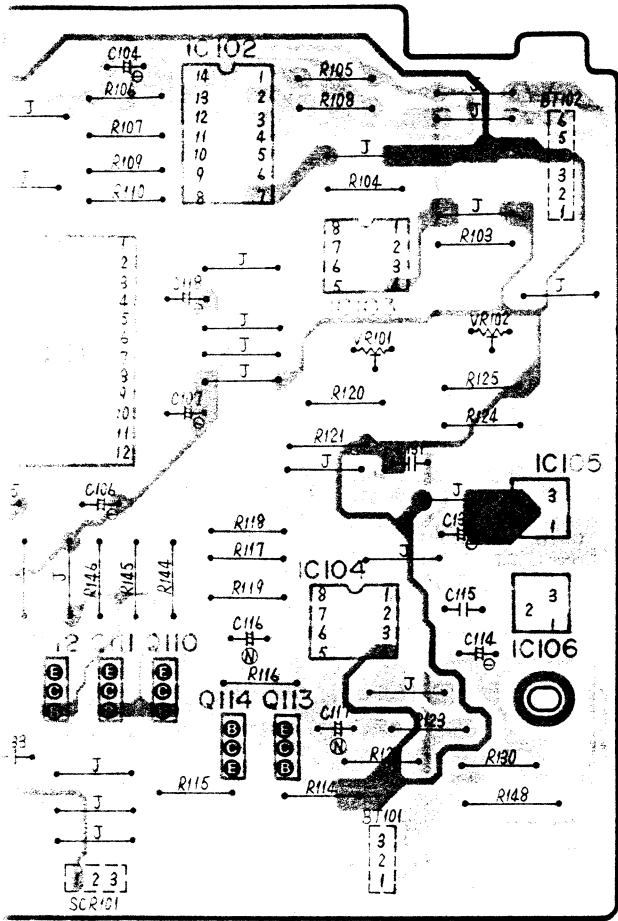

• Block diagram of driving circuit

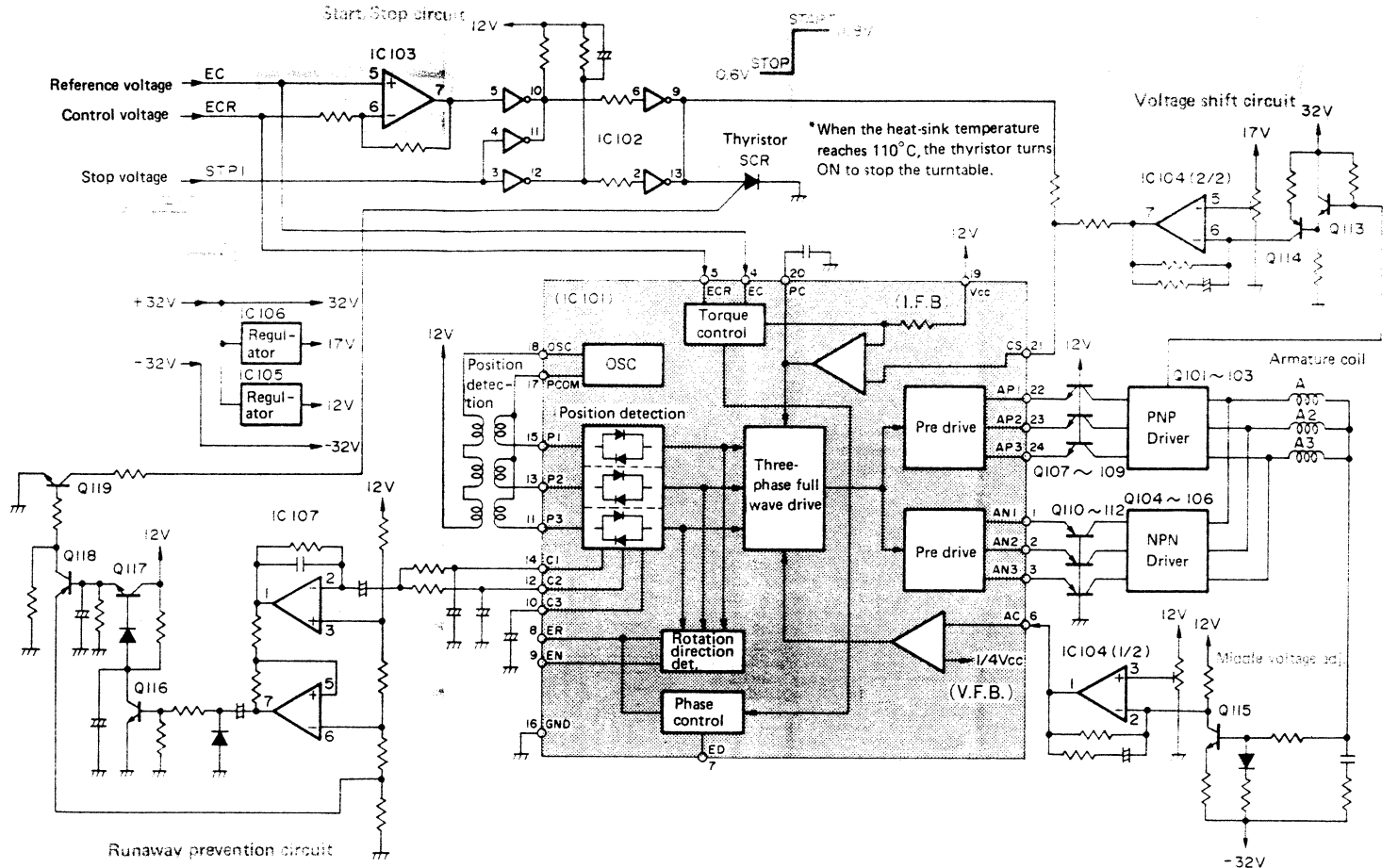

Switch circuit

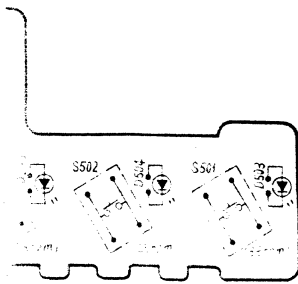

• Strobe indicator circuit

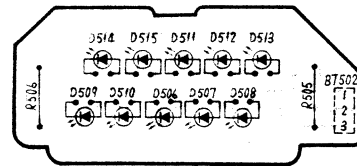

• Terminal guide of IC and transistors

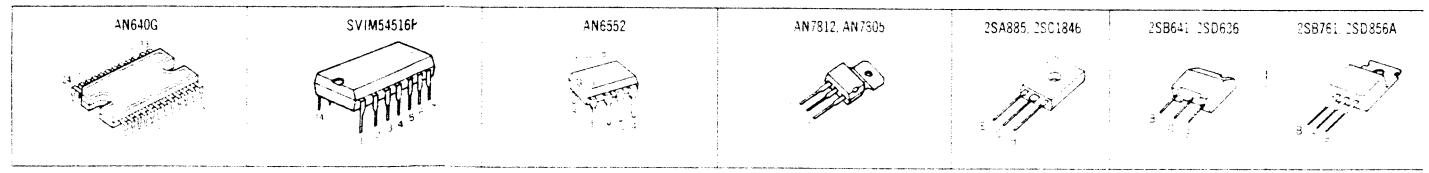

• Turntable unit (Speed selector, strobe indicator and motor coil circuit)

A
E
C
D
E
F

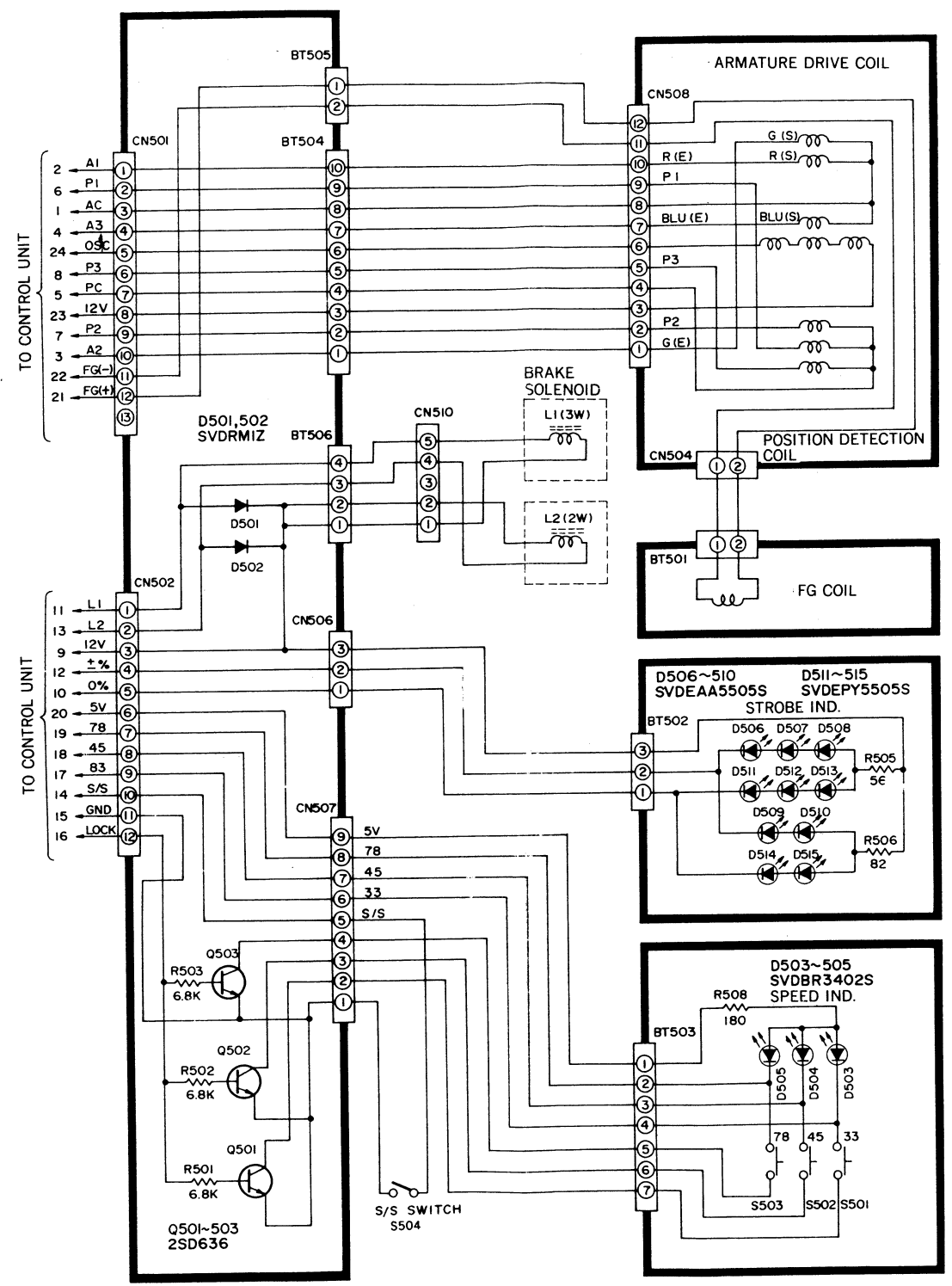

Notes:

1. The voltage value and waveform are the standard values of this measured by DC electronic voltmeter (high impedance) and oscilloscope on the basis of chassis. Therefore, the voltage value and waveform may include some error due to the internal impedance of the tester or the measuring set.
 - * Those in () are voltage in stop.
 - * Those in [] are voltage in rotation.
2. - - - - - positive voltage lines.
3. Important safety notice: Components identifier by Δ make have special characteristics important for safety. When replacing any of these components, use only manufacturer's specified parts.
 - 4. **S501** : Speed selector (33 rpm) switch.
 - 5. **S502** : Speed selector (45 rpm) switch.
 - 6. **S503** : Speed selector (78 rpm) switch.
 - 7. **S504** : Start/stop switch.

SCHEMATIC DIAGRAM (This schematic diagram may be modified at any time with the development of new technology.)

• Driving circuit

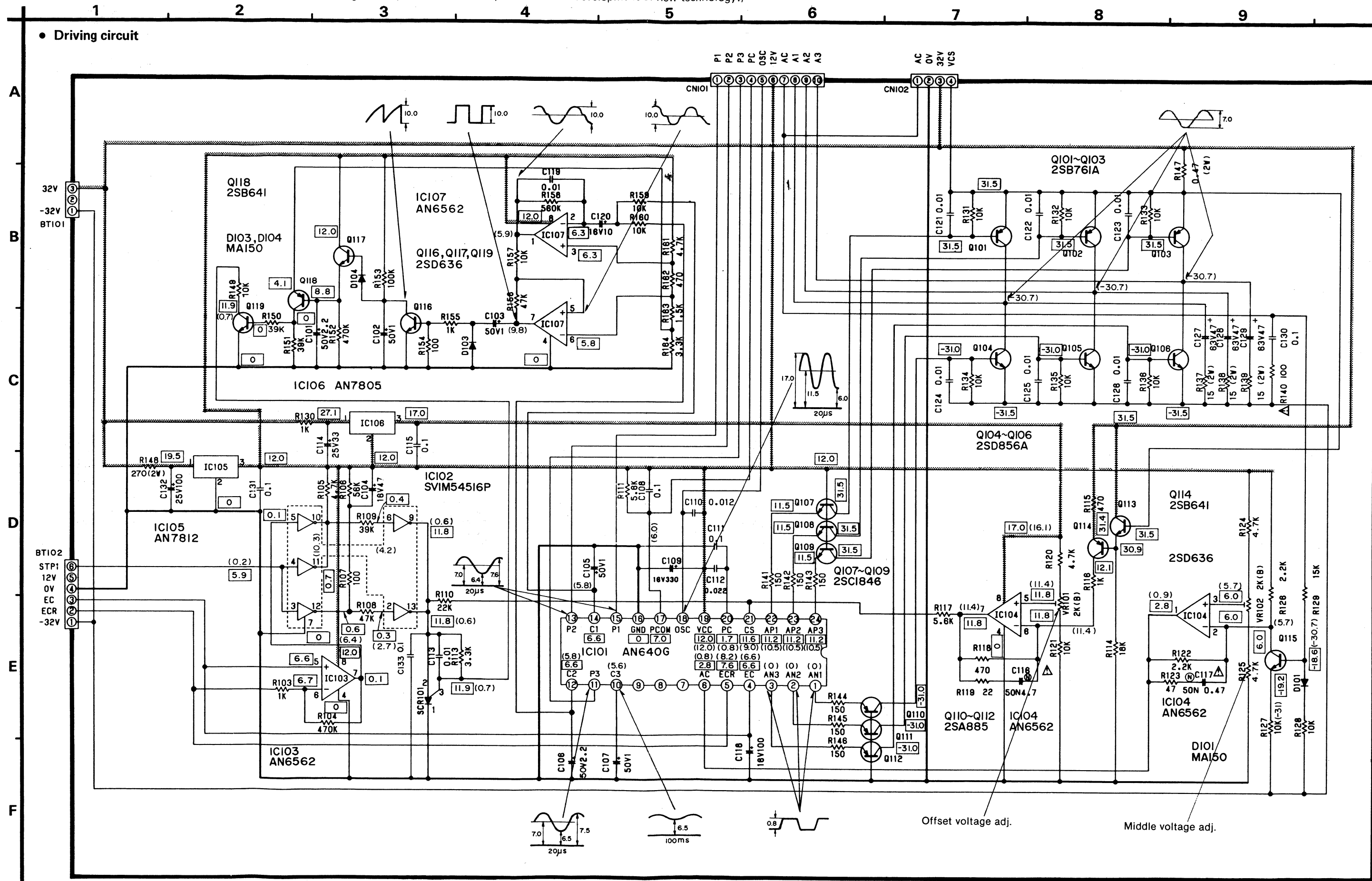

• Block diagram of control circuit

• Reference voltage and waveform at each IC pin

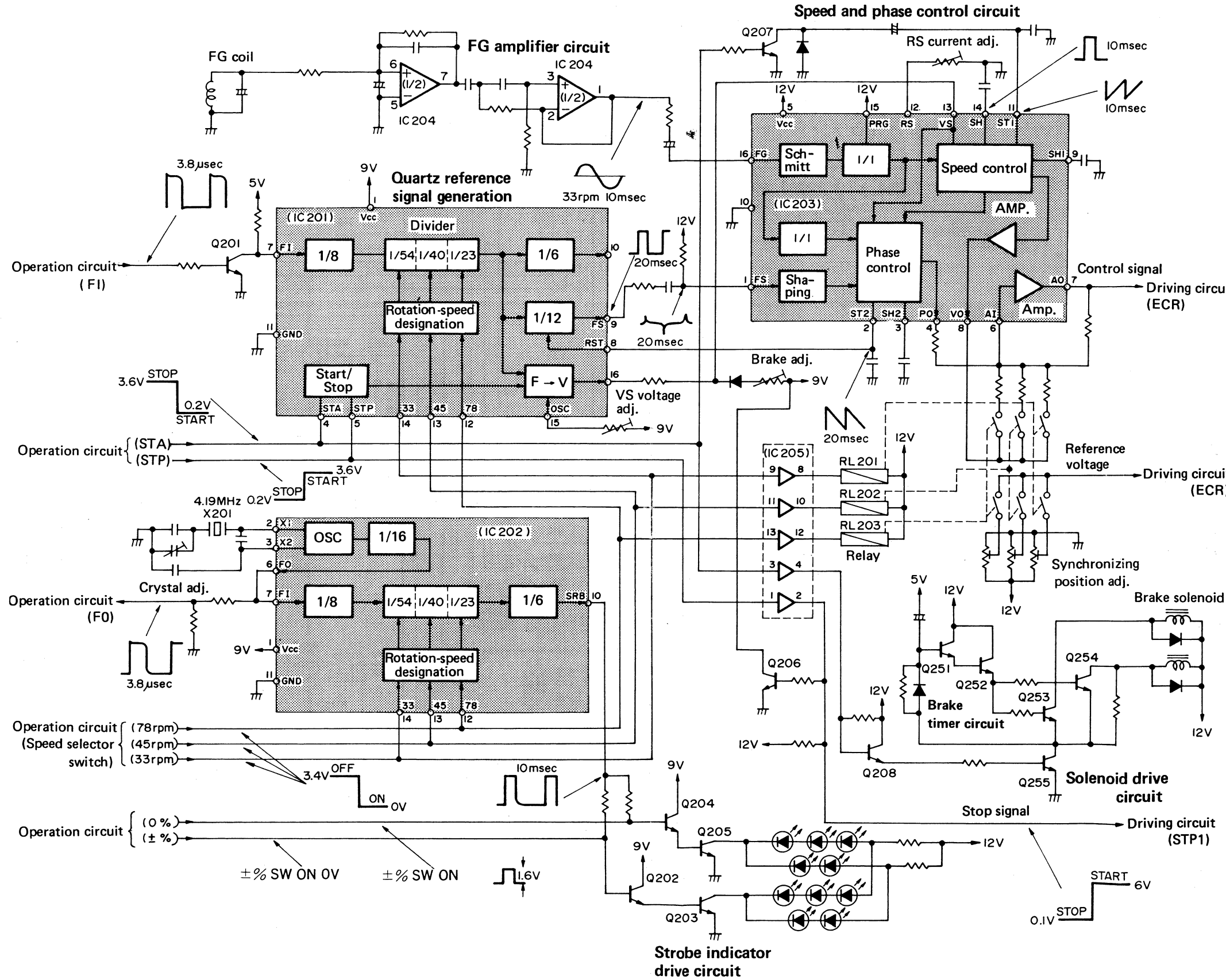
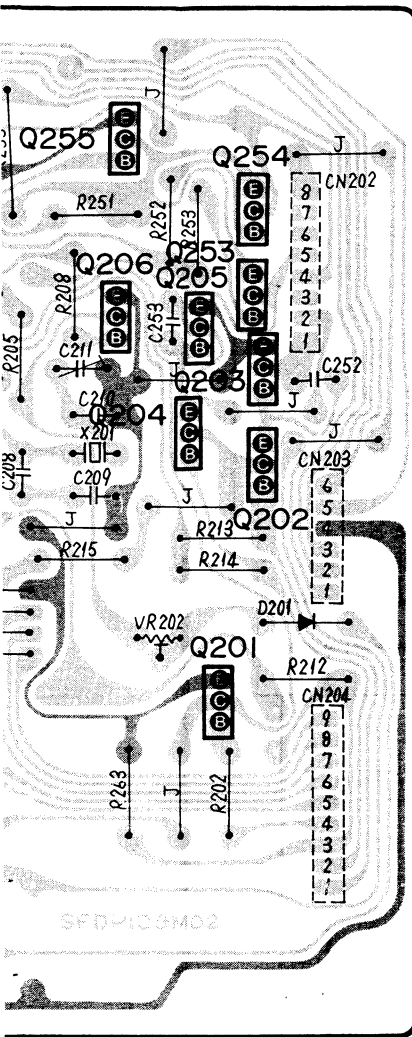

IC201 DN860		IC203 AN660	
No	STOP ROTATION(START)	No	STOP ROTATION(START)
1	9.0 9.0	1	11.8
4	3.6 0.2	2	0
5	0.2 3.6	3	6.0 5.0
7		4	6.2 6.2
8	0	5	12.0 12.0
9	4.2	6	6.4 6.4
11	0 0	7	8.2 6.7
12	33,45rpm 3.6 78rpm 0.2	8	5.2 6.4
13	33,78 " 3.6 45 " 0.2	9	7.6 6.4
14	45,78 " 3.6 33 " 0.2	10	0 0
15		11	7.8
16	0.2	12	2.6
		13	2.6
		14	7.5
		15	12.0 12.0
		16	5.8

IC202 DN860	
No	STOP ROTATION(START)
1	9.0 9.0
2	
3	
6	
7	
10	
11	0
12	33,45rpm 3.6 78rpm 0.2
13	33,78 " 3.6 45 " 0.2
14	45,78 " 3.6 33 " 0.2

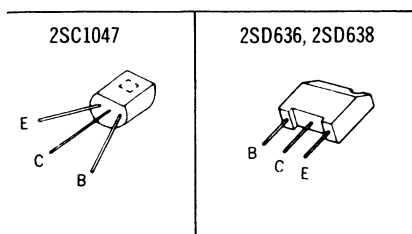

PRINTED CIRCUIT BOARD

Ground (Earth) lines

Block diagram of control circuit

Control circuit

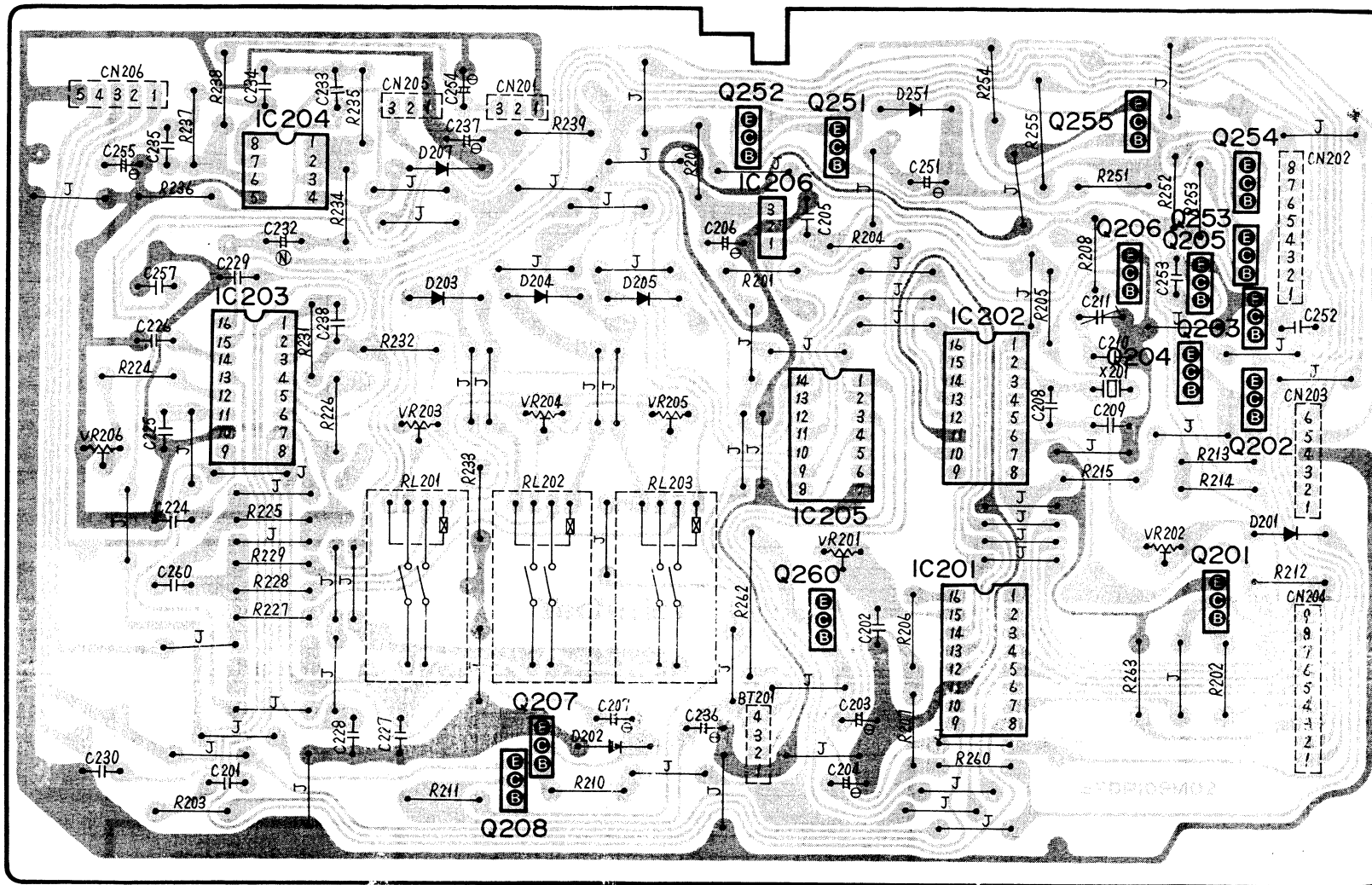

Terminal guide of IC and transistors

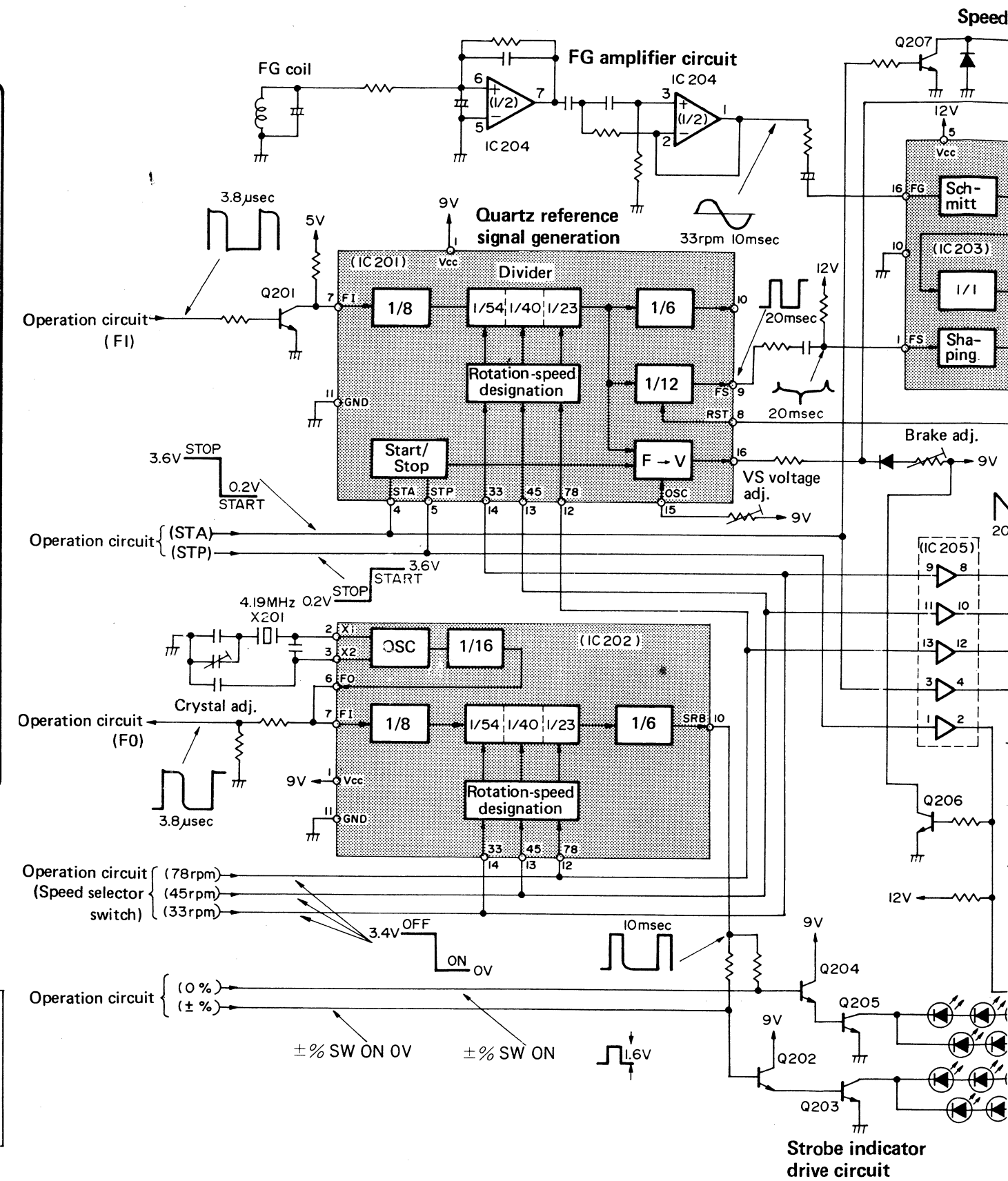
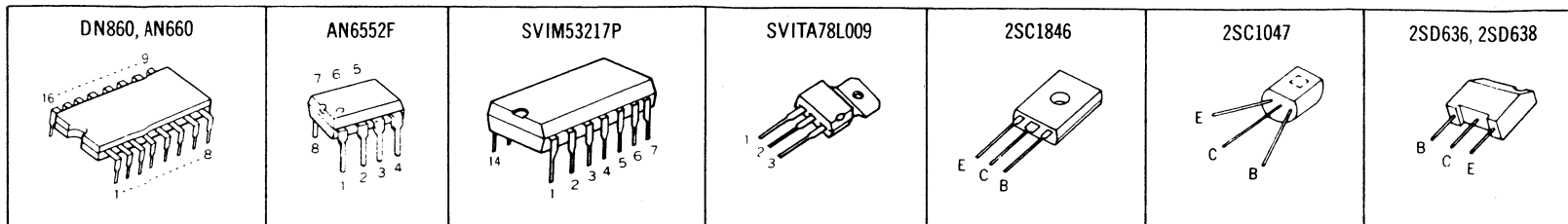

SP-10MK3 SP-10MK3

PRINTED CIRCUIT BOARD

● Operation circuit

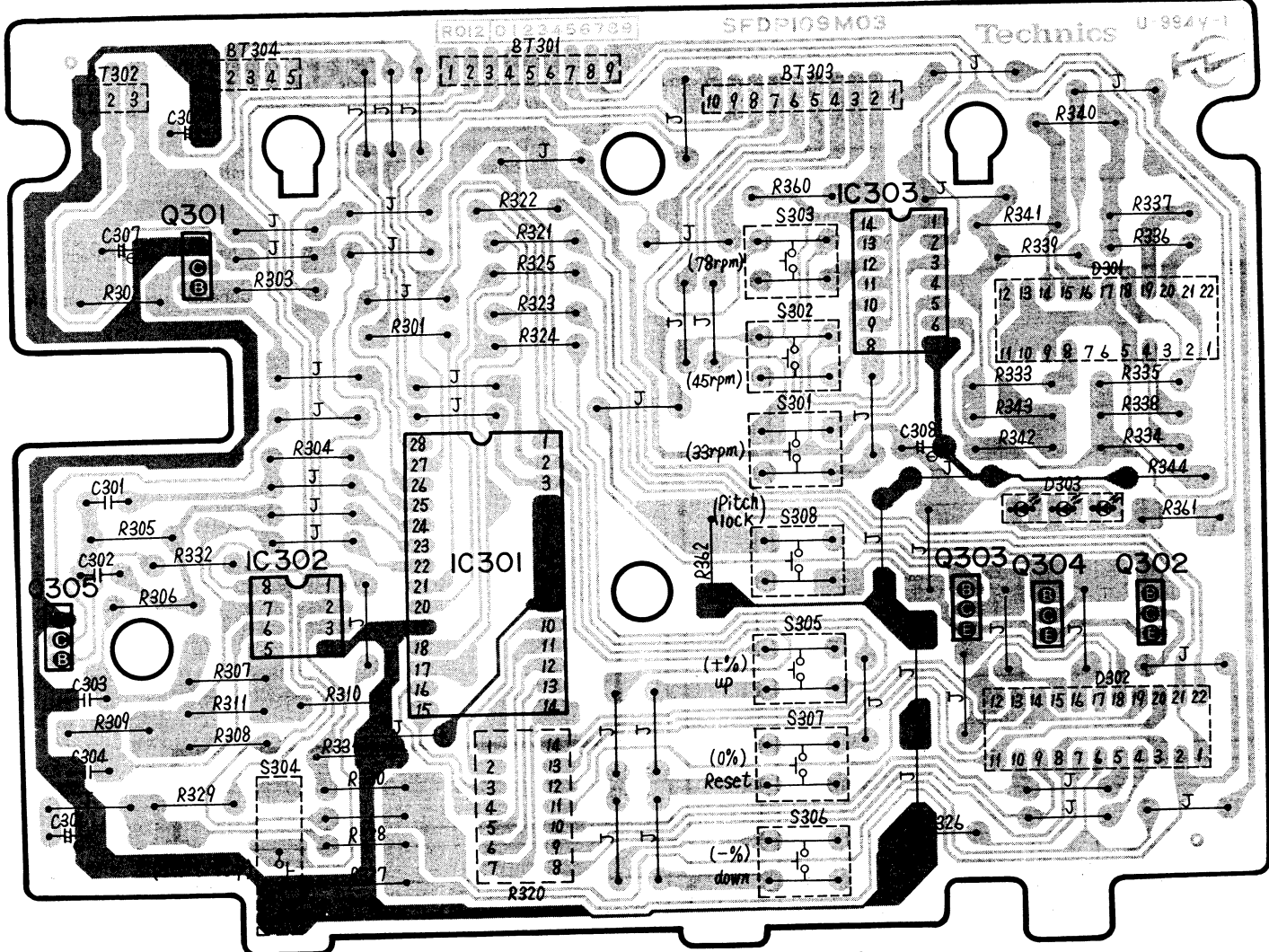

Ground (Earth) lines

● Block diagram of operation circuit

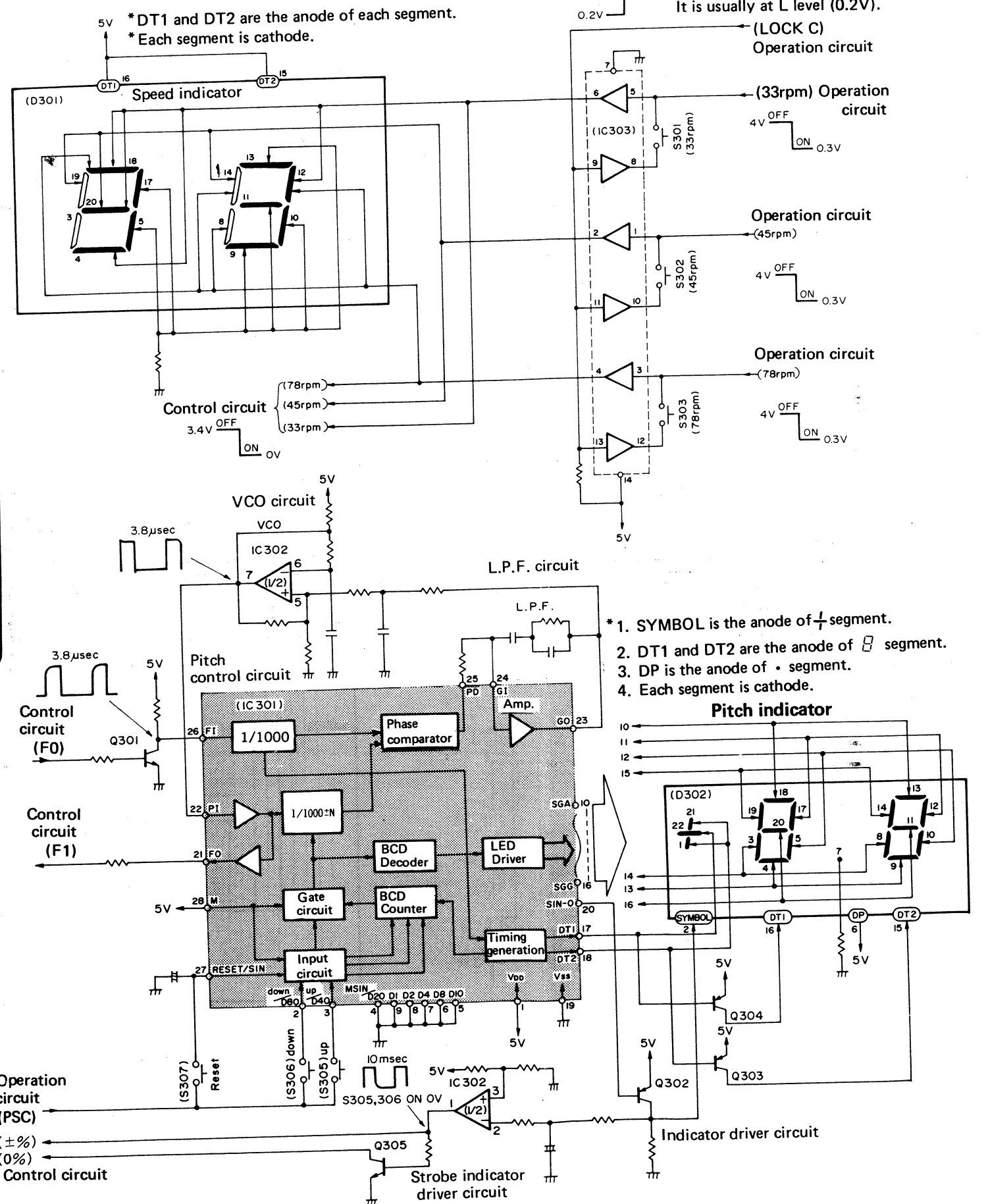

● Timing chart (When the pitch has been set to +5.9%)
IC301 pin number

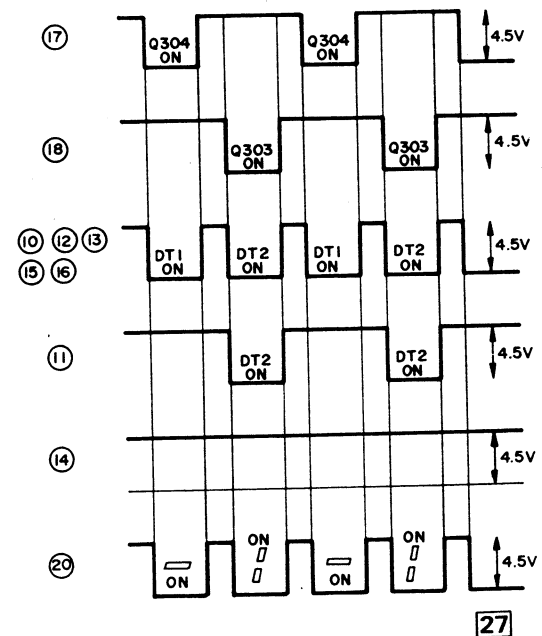

● Terminal guide of IC and transistors

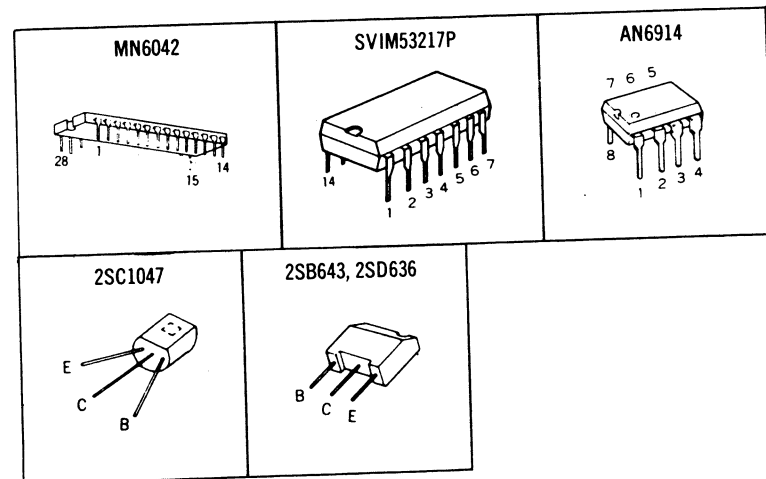

SCHEMATIC DIAGRAM (This schematic diagram may be modified at any time with the development of new technology.)

• Control circuit

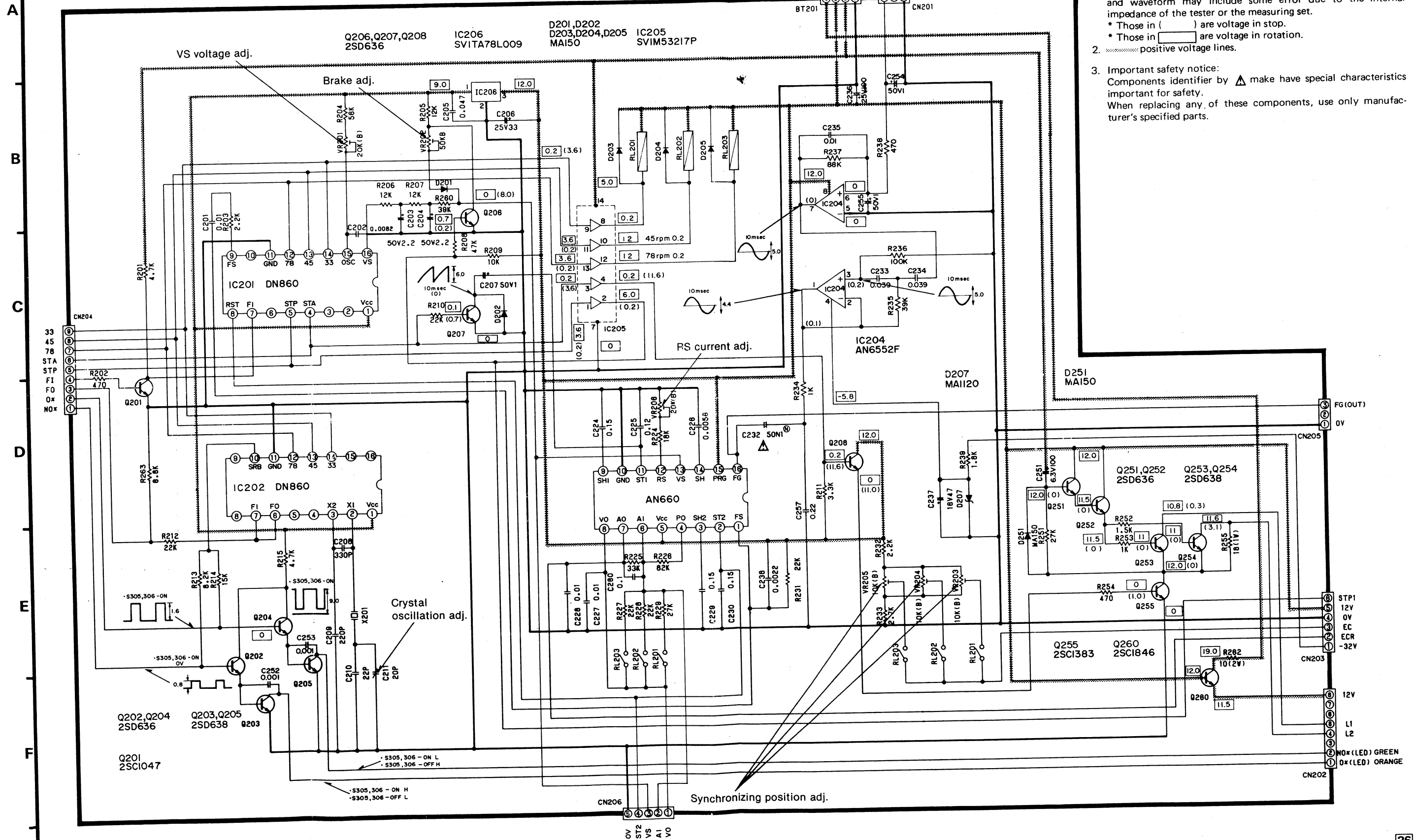

Notes:

- The voltage value and waveform are the standard values of this measured by DC electronic voltmeter (high impedance) and oscilloscope on the basis of chassis. Therefore, the voltage value and waveform may include some error due to the internal impedance of the tester or the measuring set.
 * Those in () are voltage in stop.
 * Those in [] are voltage in rotation.
- Positive voltage lines.
- Important safety notice: Components identifier by Δ make have special characteristics important for safety. When replacing any of these components, use only manufacturer's specified parts.

PRINTED CIRCUIT BOARD

Ground (Earth) lines

Block diagram of constant voltage and operation circuit

Constant voltage and operation circuit

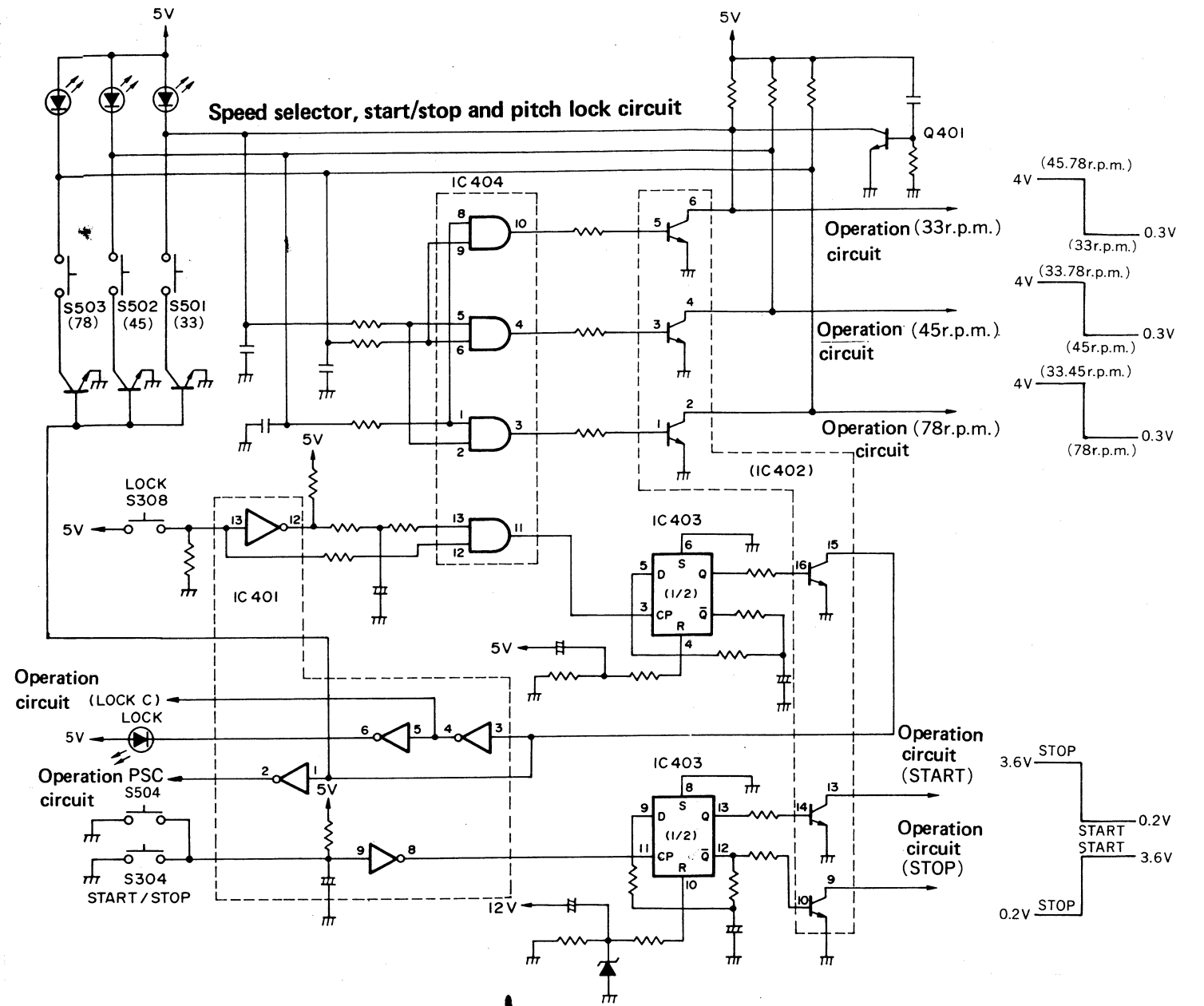
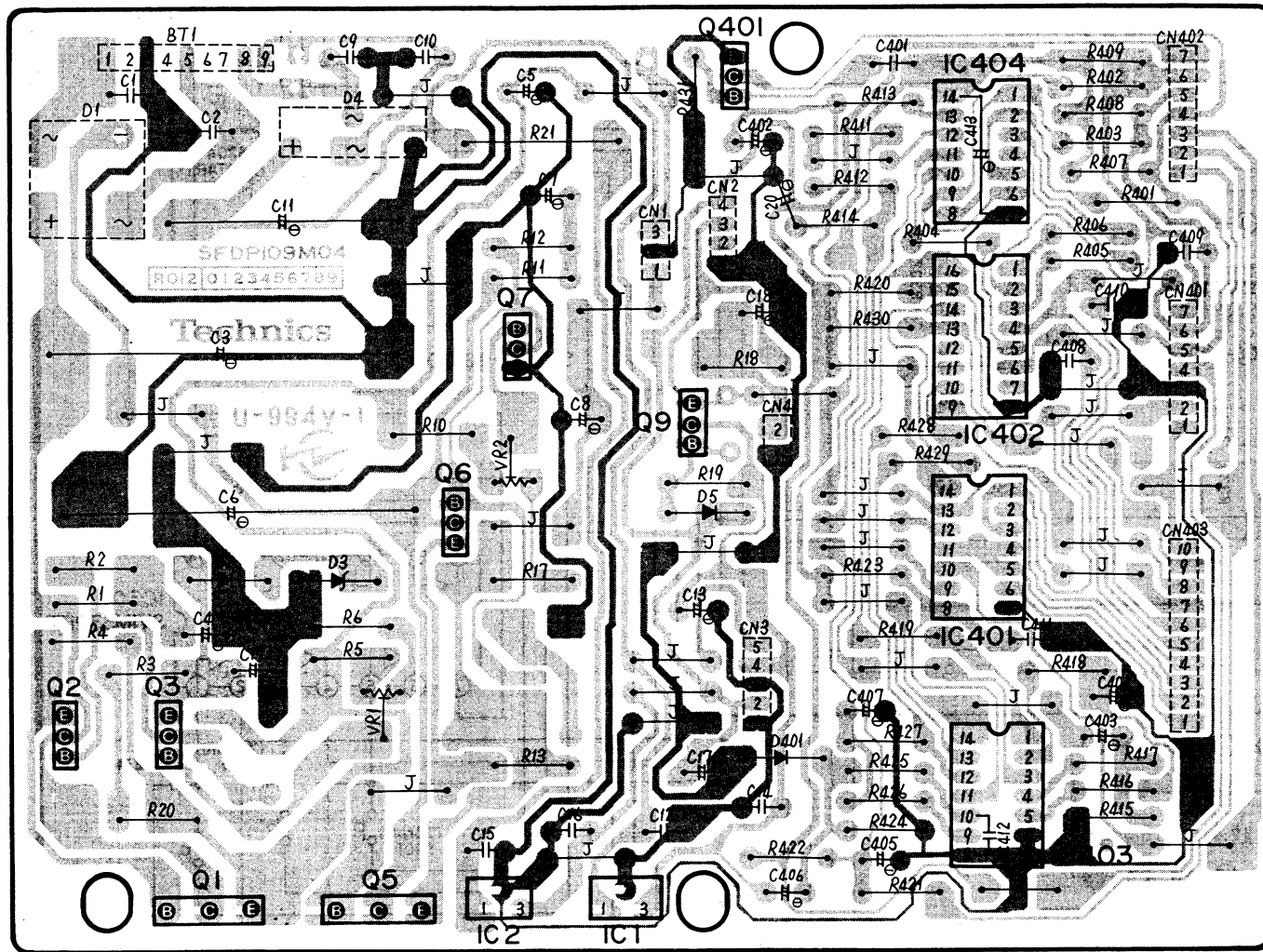

Terminal guide of IC and transistors

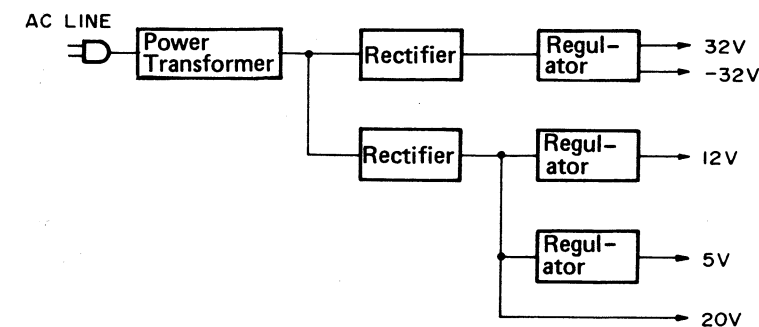
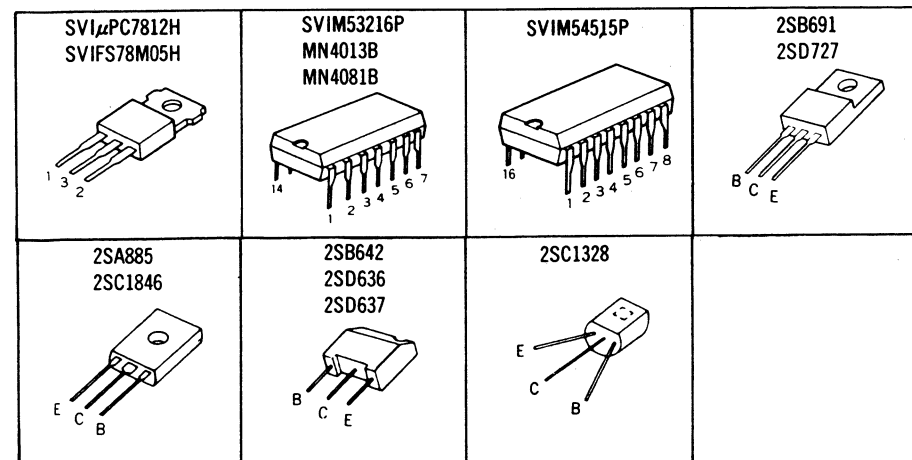

Reference voltage at each IC pin

IC404 MN4081B				
No	STOP	33rpm	45rpm	78rpm
1	4.0	4.0	0.3	4.0
2	0.3	0.3	4.0	4.0
3	0	0	0	5.0
4	0	0	5.0	0
5	0.3	0.3	4.0	4.0
6	4.0	4.0	4.0	0.3
7	0	0	0	0
8	4.0	4.0	0.3	4.0
9	4.0	4.0	4.0	0.3
10	5.0	5.0	0	0
11	0	0	0	0
12	0.1	0.1	0.1	0.1
13	5.0	5.0	5.0	5.0
14	5.0	5.0	5.0	5.0

IC402 SVIM54515P				
No	STOP	33rpm	45rpm	78rpm
1	0	0	0	0.8
2	4.0	4.0	4.0	0.3
3	0	0	0.8	0
4	4.0	4.0	0.3	4.0
5	0	0.8	0	0
6	4.0	0.3	4.0	4.0
7	0	0	0	0
8	0	0	0	0
9	0.2	3.6	3.6	3.6
10	0.8	0	0	0
11	0	0	0	0
12	0	0	0	0
13	3.6	0.2	0.2	0.2
14	0	0.8	0.8	0.8
15	3.2	3.2	3.2	3.2
16	0	0	0	0

SCHEMATIC DIAGRAM (This schematic diagram may be modified at any time with the development of new technology.)

● Operation circuit

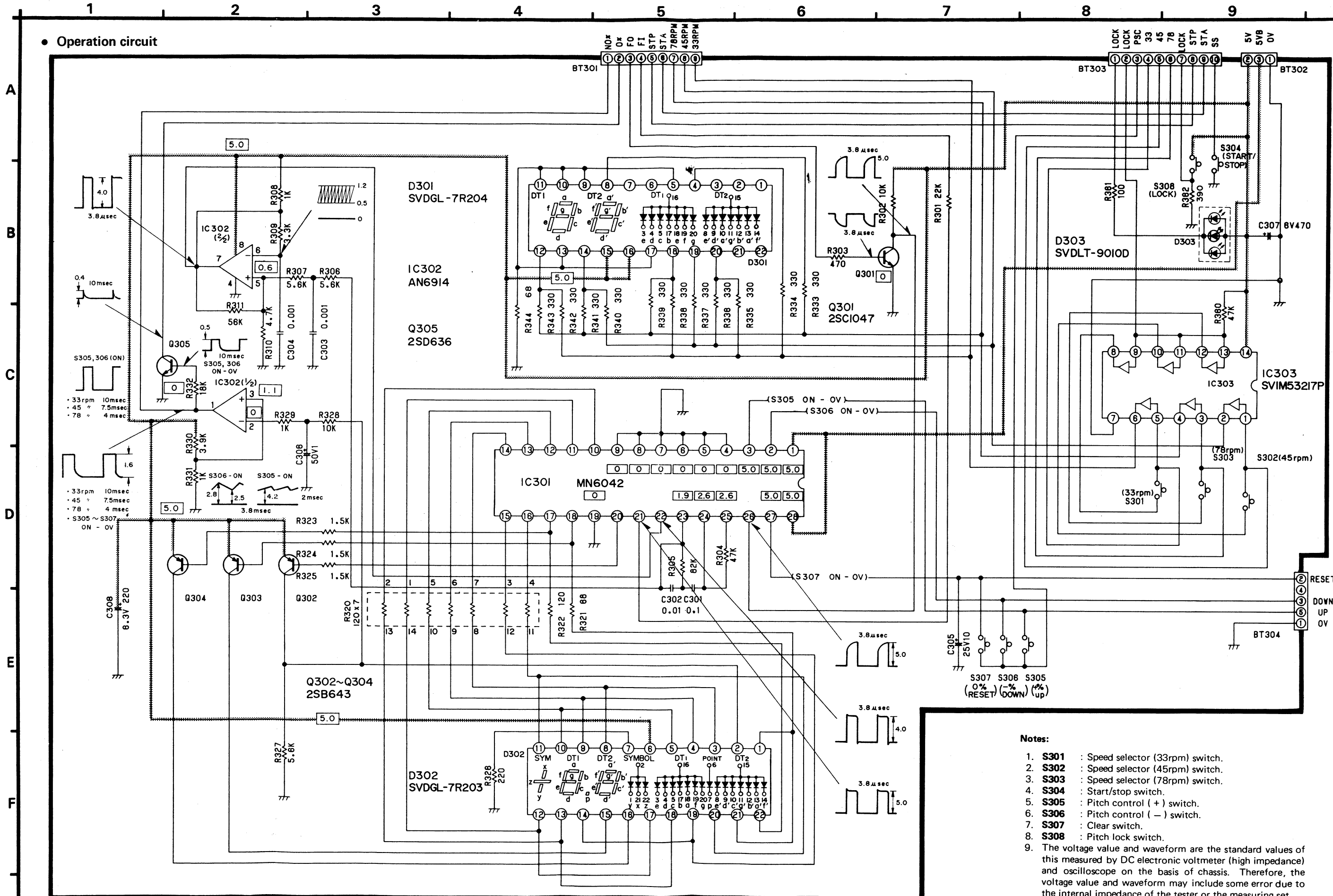

- Notes:**
1. **S301** : Speed selector (33rpm) switch.
 2. **S302** : Speed selector (45rpm) switch.
 3. **S303** : Speed selector (78rpm) switch.
 4. **S304** : Start/stop switch.
 5. **S305** : Pitch control (+) switch.
 6. **S306** : Pitch control (-) switch.
 7. **S307** : Clear switch.
 8. **S308** : Pitch lock switch.
 9. The voltage value and waveform are the standard values of this measured by DC electronic voltmeter (high impedance) and oscilloscope on the basis of chassis. Therefore, the voltage value and waveform may include some error due to the internal impedance of the tester or the measuring set.
 10. Positive voltage lines.

● Power fuse ■ Ground (Earth) lines

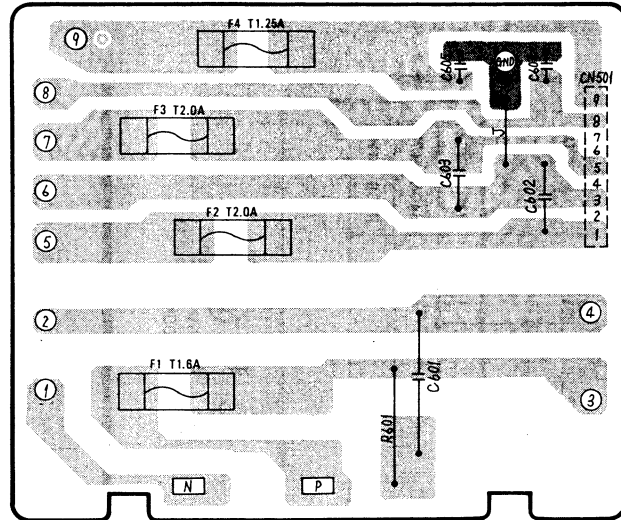

Note:

1. **S1** : Power switch in "on" position.
2. **S2** : Voltage selector switch in "110V" position.
3. Important safety notice:
Components identifier by Δ make have special characteristics important for safety.
When replacing any of these components, use only manufacturer's specified parts.

● Power supply circuit

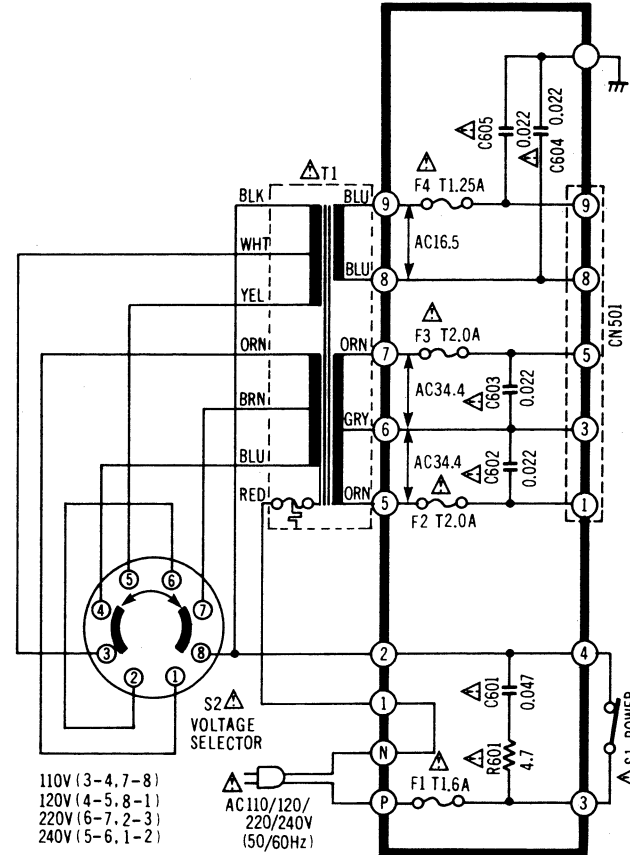

■ EXPLODED VIEWS

● Turntable platter and motor

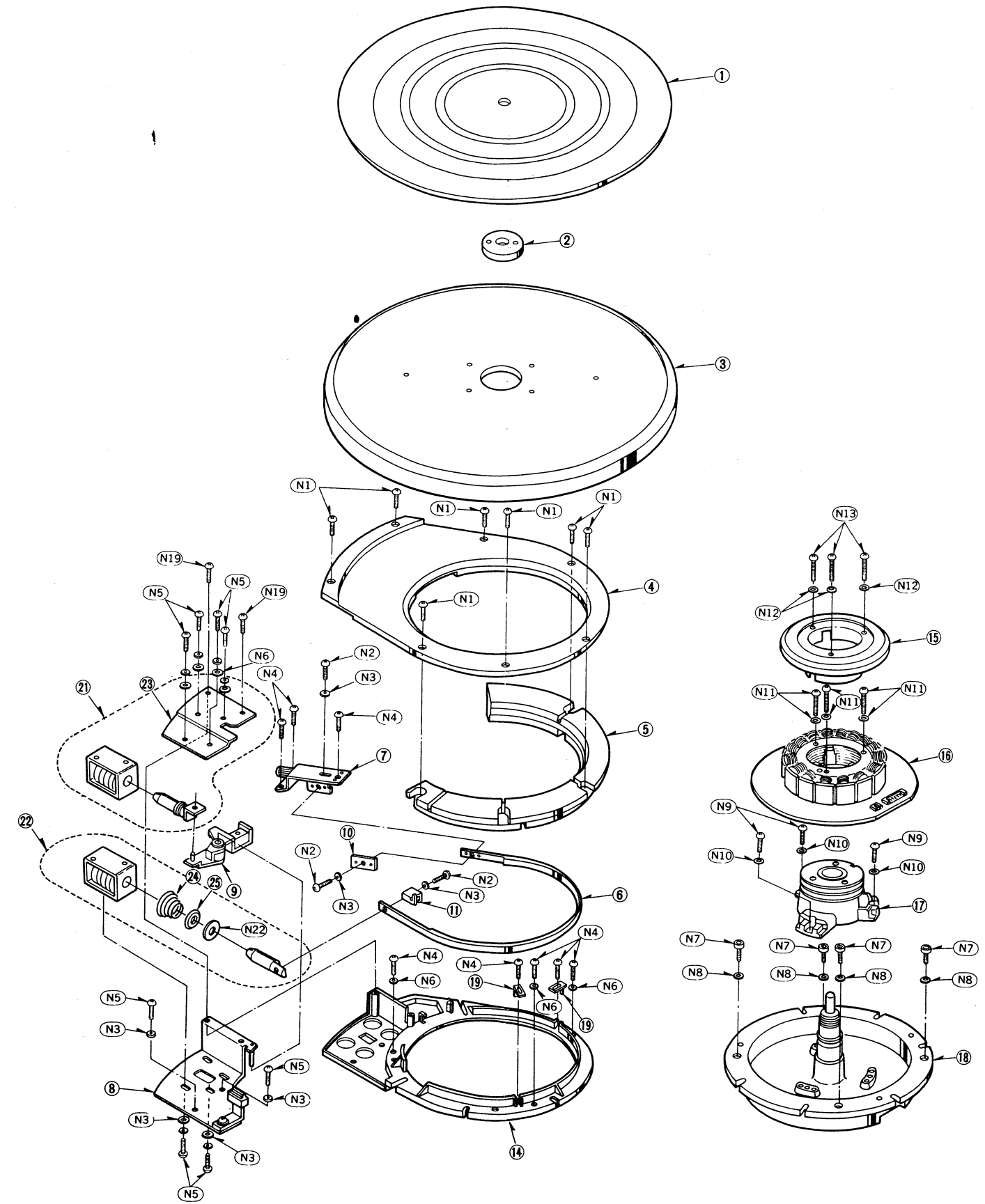

■ REPLACEMENT PARTS LIST...Electric Parts

- Notes:**
1. Part numbers are indicated on most mechanical parts. Please use this part number for parts orders.
 2. Important safety notice:
Components identified by Δ mark have special characteristics important for safety.
When replacing any of these components, use only manufacturer's specified parts.
 3. Bracketed indications in Ref. No. columns specify the area. Parts without these indications can be used for all areas.
 4. The "S" mark is service standard parts and may differ from production parts.

Ref. No.	Part No.	Description	Ref. No.	Part No.	Description	Ref. No.	Part No.	Description
INTEGRATED CIRCUITS			Q113	2SD636	Voltage Shift	D501, 502	SVDRM1Z	Switching
IC1, 105	SVIUPC7812H	Regulator	Q114	2SB641	Voltage Shift	D503 ~ 505	SVDEBR3402S	Speed Indicator
IC2, 106	SVIFS78M05H	Regulator	Q115 ~ 117	2SD636	Runaway Prevent	D506 ~ 510	SVDEAA5505S	Strobe Indicator
IC101	AN640G	Turntable Drive	Q118	2SB641	Runaway Prevent	D511 ~ 515	SVDEPY5505S	Strobe Indicator
IC102	SVIM54516P	Inverter	Q119	2SD636	Runaway Prevent	SWITCHES		
IC103, 104, 107	AN6562	Operation Amp.	Q201	2SC1047-D	Buffer	S1	Δ ESB90619S	Power
IC201, 202	DN860	Control	Q202, 204	2SD636	Strobe Drive	S2	Δ ESE37200	Voltage Selector
IC203	AN660	Control	Q203, 205	2SD638	Strobe Drive	S301 ~ 303	EVQQR02K	Speed Selector
IC204	AN6552F	FG Amplifier	Q206 ~ 208	2SD636	Switching	S304	SFDSSS01	(Control Unit)
IC205	SVIM53217P	Relay Drive	Q251, 252	2SD636	Brake Timer	S305 ~ 308	EVQQR02K	Start/Stop
IC206	SVITA78L009	Regulator	Q253, 254	2SD638	Solenoid Drive	S501 ~ 503	EVQQR02K	(Control Unit)
IC301	MN6042	Synthesizer/Pitch Control	Q255	Δ 2SC1383Q	Solenoid Drive	S504	SFDSSS01	Pitch Control
IC302	AN6914	Control	Q260	2SC1846	Regulator	VARIABLE RESISTORS		
IC303	SVIM53217P	Strobe Drive	Q301	2SC1047-D	Regulator	VR1, 2	EVMH1GA00B23	Constant Voltage
IC401	SVIM53216P	Speed Selector	Q302 ~ 304	2SD643	Buffer	VR101, 102	EVMJ1GA01B23	Adj., 2k Ω (B)
IC402	SVIM54515P	Inverter	Q305, 401	2SD636	Pitch Indicator Drive	VR201, 206	EVMJ1GA01B24	Offset Voltage and Middle Voltage Adj., 2k Ω (B)
IC403	MN4013B	D-Type Fli-Flop	Q501 ~ 503	2SD636	Speed Indicator Drive	VR202	EVMJ1GA01B54	VS Voltage and RS Current Adj., 20k Ω (B)
IC404	MN4081B	2-Input AND Gate				VR203 ~ 205	EVMJ1GA01B14	Brake Adj., 50k Ω (B)
TRANSISTORS			DIODES					
Q1	2SD727	Regulator	D1	Δ SVDS4VB40	Rectifier			
Q2	2SC1846	Regulator	D2, 5	S MA162A	Rectifier			
Q3	2SD637	Regulator	D3	S MA1056	5.6V Zener			
Q5	2SB691	Regulator	D4	Δ SVDS1RBA20F	Rectifier			
Q6	2SA885	Regulator	D101, 103, 104	S MA162A	Rectifier			
Q7	2SA886	Regulator	201 ~ 205	S RVDRD12FB	12V Zener			
Q9	Δ 2SC1383Q	Regulator	D207	S MA162A	Rectifier			
Q101 ~ 103	2SB761A	Driver	D251	S MA162A	Rectifier			
Q104 ~ 106	2SD856A	Driver	D301	SVDGL-7R204	Speed Indicator			
Q107 ~ 109	2SC1846	Buffer	D302	SVDGL-7R203	Pitch Indicator			
Q110 ~ 112	2SA885	Buffer	D303	SVDLT9010D	Pitch Lock Indicator			
			D401	MA1051A	5.1V Zener			

SCHEMATIC DIAGRAM (This schematic diagram may be modified at any time with the development of new technology.)

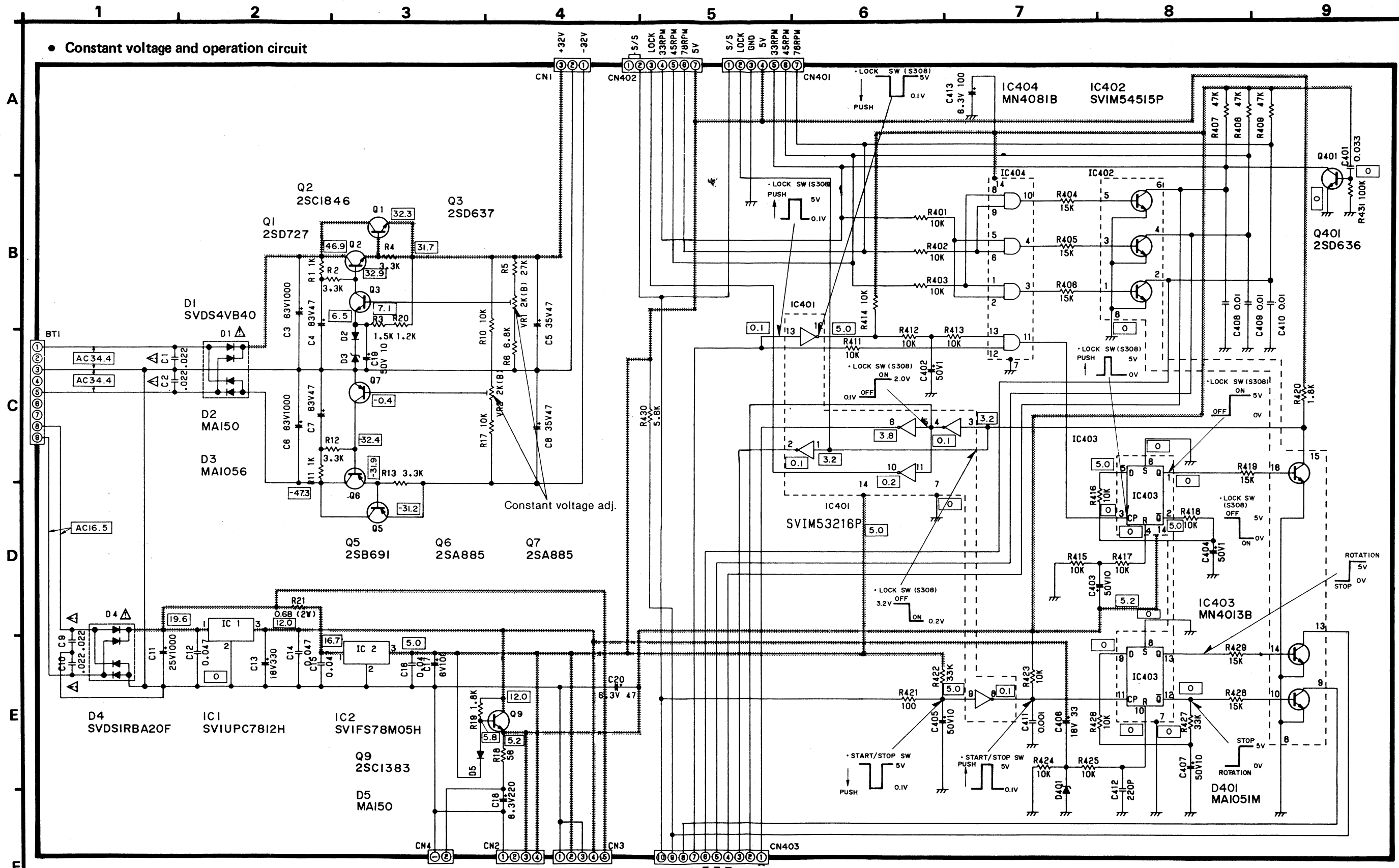

Notes:

- The voltage value and waveform are the standard values of this measured by DC electronic voltmeter (high impedance) and oscilloscope on the basis of chassis. Therefore, the voltage value and waveform may include some error due to the internal impedance of the tester or the measuring set.
 * Those in () are voltage in stop.
 * Those in [] are voltage in rotation.
- positive voltage lines.
- Important safety notice: Components identifier by Δ make have special characteristics important for safety. When replacing any of these components, use only manufacturer's specified parts.

• Cabinet

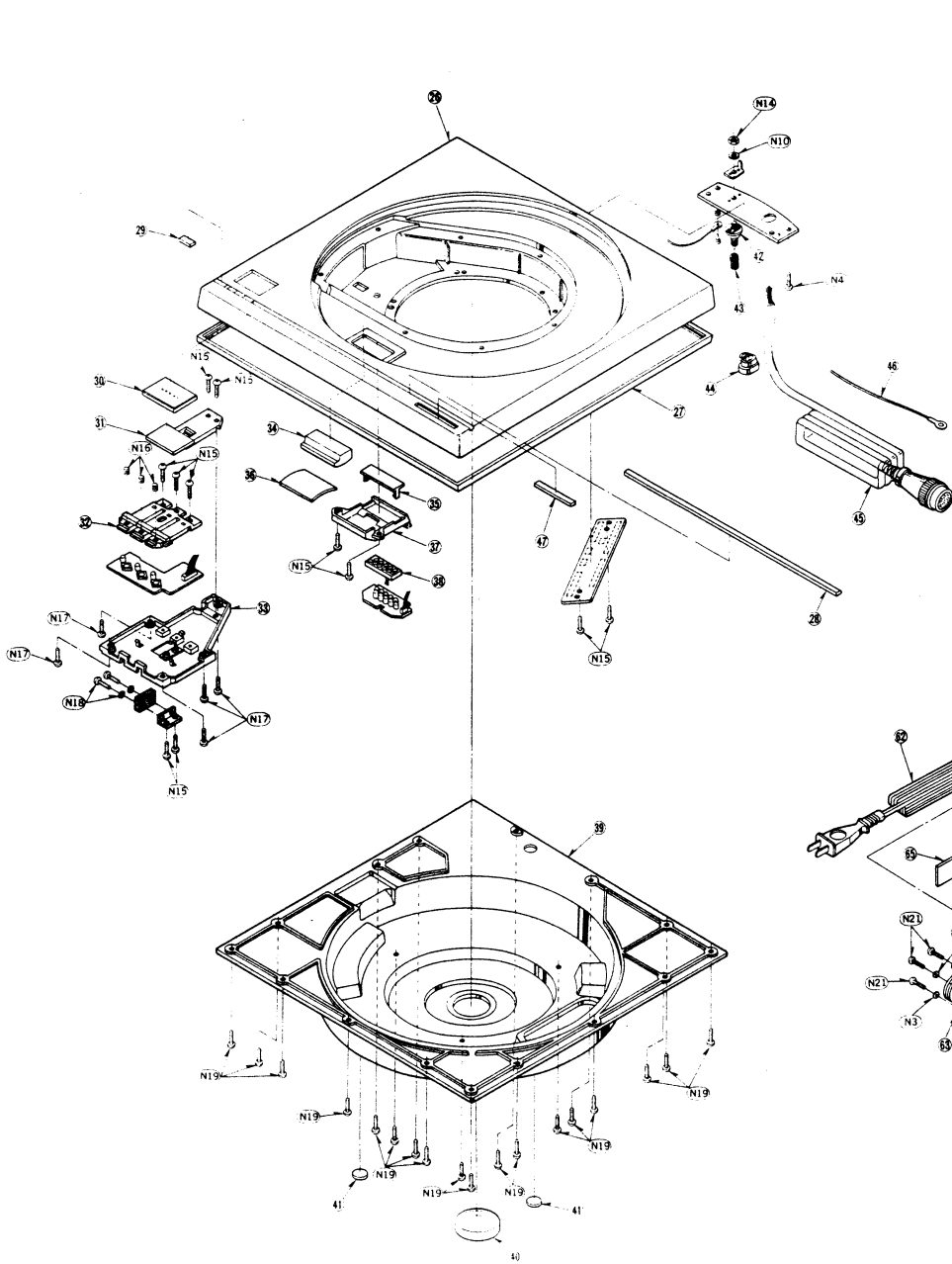

• Control unit

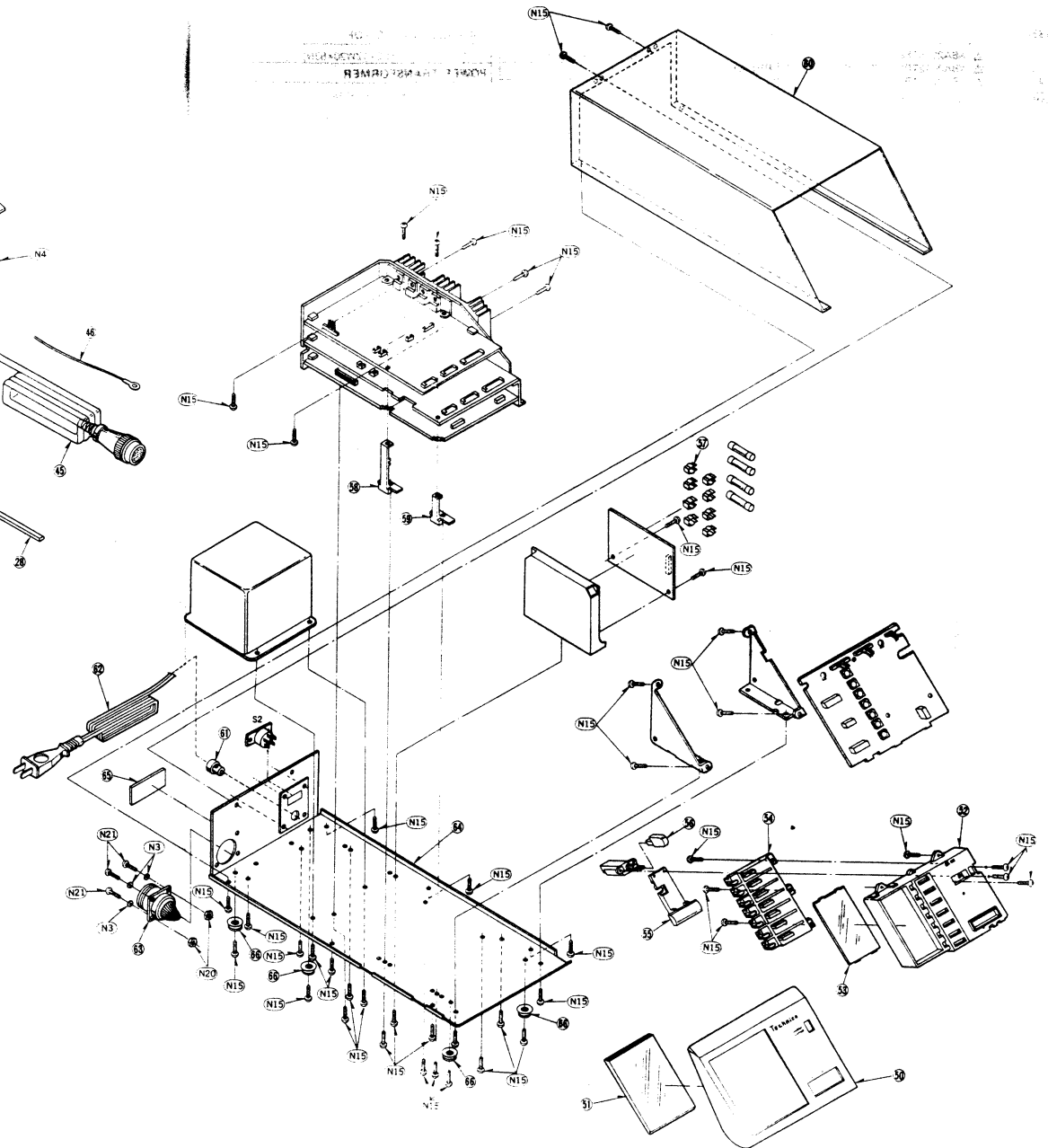

Continued from page 35

Ref. No.	Part No.	Description	Ref. No.	Part No.	Description	Ref. No.	Part No.	Description
FUSES			CRYSTAL			VARIABLE CAPACITOR		
11	Δ XBA2C10T1R0	T 1.6A	12	SVQ0306115	419320110	13	ECV12W20X53N	
12	Δ XBA2C12T1R0	T 1.25A	RELAY			POWER TRANSFORMER		
13, 4	Δ XBA2C20T1R0	T 2.0A	RL201 ~ 203	SFDYC10-01		T1	Δ SLT85HE14E	Power Source
COMPONENT COMBINATION			THYRISTOR					
R320	EXBRB7121M	120Ω x 7	SCR101	SVTTT201-110				

REPLACEMENT PARTS LIST... Cabinet and Chassis Parts

- Notes:**
- Part numbers are indicated on most mechanical parts. Please use this part number for parts orders.
 - Important safety notice. Components identified by Δ mark have special characteristics important for safety. When replacing any of these components, use only manufacturer's specified parts.
 - Bracketed indications in Ref. No. columns specify the area. Parts without these indications can be used for all areas.
 - The "S" mark is service standard parts and may differ from production parts.
 - The parenthetical numbers in the columns of description stand for the quantity per set.

Ref. No.	Part No.	Description	Ref. No.	Part No.	Description
CABINET and CHASSIS PARTS			Control Unit Section		
• Turntable and Motor Section			50	SFAC109N03	Panel, Front (1)
1	SFTG109N01	Turntable Assy (1)	51	SFAM109N17	Glass, Front Panel (1)
2	SFTM109N01	Ring, Turntable (1)	52	SFJM109N15	Frame, Control Section (1)
3	SFTS109N01A	Turntable (1)	53	SFUM109N19	Filter, Control Section (1)
4	SFLM109N06	Cover, Cabinet Panel (1)	54	SFUM109N19E	Button, Control (1)
5	SFGH109N01	Cushion Rubber (1)	55	SFUM109N20E	Button, Start, Stop (1)
6	SFLP109N05E	Bracket Panel (1)	56	SFKT109N05	Button, Power Switch (1)
7	SFLP109N06E	Brake Belt Assy (1)	57	SJT347	Terminal, Fuse (8)
8	SFLP109N06E	Rack, Support (1)	58	SFUM109N21	Shaft, Support (2)
9	SFLP109N03E	Plate, Solenoid (1)	59	SFUM109N22	Shaft, Support (2)
10	SFLM109N13E	Lever Assy, Brake (1)	60	SFUP10914E	Cabinet (1)
11	SFLP109N08	Bracket, Brake Belt (1)	61 [EK] Δ	SJA139	AC Cord (1)
12	SFLP109N16	Plate, Brake Belt (1)	61 [KLI] Δ	SJAG23	AC Cord (1)
13	SFLM109N12	Case, Brake Belt (1)	61 [Other] Δ	SJA137	AC Cord (1)
14	SFLM109N06	Cover, Stator Coil (1)			
15	SFSP109N11A	Motor Coil Assy (1)	62 [EK]	SFSR5N-4	Bushing, AC Cord (1)
16	SFVG109N01A	FG Base Assy (1)	62 [Other Areas]	SFSR4N-4	Bushing, AC Cord (1)
17	SFM2109N02A	Turntable Shaft Assy (1)	63	SFDJ109N04E	Socket, (24P) (1)
18	SFLP109N15	Plate, Belt Control (1)	64	SFUP109N01	Bottom Cover (1)
19	SFDQ109N02E	Solenoid Assy (1)	65 [E, EC]	SFNN109S01	Name Plate (1)
20	SFDQ109N03E	Solenoid Assy (1)	65 [EK, XLI]	SFNN109G01	Name Plate (1)
21	SFLP109N19	Plate, Solenoid Assy (1)	65 [XA, XM]	SFNN109X01	Name Plate (1)
22	SFPA109N02	Spring, Solenoid (1)	65 [Other Areas]	SFNN109R01	Name Plate (1)
23	SFPA109N03	Rubber, Solenoid (1)	66	SKL261	Foot, Set (6)
• Main Cabinet Section			SCREWS, WASHERS AND NUTS		
24	SFA109N001	Cabinet (1)	N1	S XTN3+10BFZ	Screw, # 3 x 10 (5)
25	SFPM109N02	Speaker, Cabinet (1)	N2	S XSN3+6S	Screw, # 3 x 6 (2)
26	SFLM109N01	Ornament Plate (1)	N3	S XWA3B	Washer, #3 (6)
27	SFLM109N02	Ornament Plate (1)	N4	S XTV3+8BFN	Screw, # 3 x 8 (9)
28	SFKT109N01	Ornament, Start, Stop Button (1)	N5	S XSN3+5S	Screw, # 3 x 5 (8)
29	SFLM109N06E	Button, Start, Stop (1)	N6	S XWE3	Washer, #3 (7)
30	SFLM109N09E	Button, Speed Selector (1)	N7	KVE4A12FN	Screw, # 4 x 12 (4)
31	SFLM109N07	Guide, Start, Stop Button (1)	N8	S XWA4B	Washer, #4 (4)
32	SFLM109N03	Cover, Straps (1)	N9	S XSN4+10S	Screw, # 4 x 10 (3)
33	SFLM109N02	Filter, Straps (1)	N10	S XWA4B	Washer, #4 (3)
34	SFLM109N01	Speaker, Straps Case (1)	N11	KXN3+C10S	Screw, # 3 x 40 (2)
35	SFLM109N05	Case, Straps (1)	N12	SFX0109N01	Washer, #3 (2)
36	SFLM109N06	Speaker, Straps (1)	N13	SXSB3+35FZS	Screw, # 3 x 35 (3)
37	SFLM109N07	Case, Straps (1)	N14	S XNG4ES	Nut, #4 (1)
38	SFLM109N08	Speaker, Straps (1)	N15	S XTV3+8BFZ	Screw, # 3 x 8 (39)
39	SFLM109N09	Speaker, Straps (1)	N16	KXE26D5FP	Screw (3)
40	SFLM109N10	Speaker, Straps (1)	N17	S XTN3+8BFZ	Screw, # 3 x 8 (5)
41	SNEZ1R	Terminal, Ground (8)	N18	KXN23+C10	Screw, # 2.3 x 10 (2)
42	SNEZ1S-1	Knob, Ground Terminal (1)	N19	S XSN3+10TFZ	Screw, # 3 x 10 (29)
43	SFPA1P-2	Bushing, AC Cord (1)	N20	S XN03ES	Nut, #3 (4)
44	SFEZ109N01A	AC Cord (1)	N21	S XN03+5S	Screw, # 3 x 5 (4)
45	SFEZ109N04E	Ground Wire (1)			
46	SFB109N01	Base, Terminal (1)			

Service Manual

Universal Tonearm
EPA-100MK2

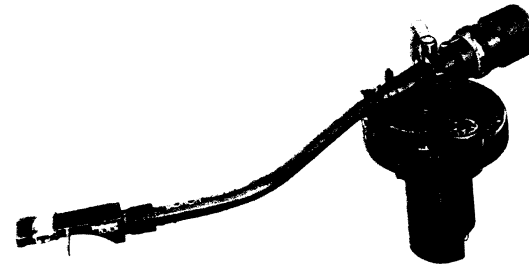

English

Specifications subject to change without notice
Weight and dimensions shown are approximate

Specifications

Type :	Universal Tonearm with Variable Dynamic Damping system
Bearings :	Gimbal suspension type with 20 precision ground ruby ball bearings
Tubular tonearm :	Boron titanium
Effective length :	250 mm
Overall range :	322 ~ 350 mm
Arm rear range :	66.5 ~ 94.5 mm
Height adjustment range :	44 ~ 64 mm from base installation surface to center of tube (helicoïd part: 20 mm)
Overhang :	15 mm
Offset angle :	21°
Horizontal tracking error angle :	+1°6' (internal perimeter of 30 cm record) +2°6' (external perimeter of 30 cm record)
Friction :	5 mg (horizontally and vertically)
Effective mass :	22 g (at 6.5 g. cartridge weight, 1.25 g stylus pressure)
Resonance frequency :	9.8 Hz (at 6.5 g. cartridge weight, 1.25 stylus pressure 12×10^{-6} cm/dyne compliance)

Resonance acute angle (Q) : 6 dB or less (at optimum adjustment)

Damping adjustment range :

Damping selector calibrations	Cartridge compliance (100 Hz dynamic) *
4 ~ 5	more than 15×10^{-9} cm/dyne
2 ~ 4	$10 \sim 15 \times 10^{-9}$ cm/dyne
1 ~ 2	$5 \sim 10 \times 10^{-9}$ cm/dyne

Stylus pressure adjustment range : 0 ~ 2 g

Headshell weight : 9.5 g (boron-aluminum)

Cartridge mounting dimensions : 12.7 mm (1/2 inch) mounting space

Headshell terminal lug : 1.2φ, for 4-pin terminal

Cartridge weight range : 5 ~ 10 g

Arm installation opening : 62 mmφ

DC resistance of PU output cords : 39 mΩ/m

Capacity of PU output cords : 41 pF/m

Technics

Deutsch

TECHNISCHE DATEN

Anderungen per technischen Daten vorbehalten.
Die angegebenen Gewichts- und Abmessungsdaten sind ungefähre Werte.

Typ: Universal-Tonarm mit "Variable Dynamic Damping System"

Lager: Kardanische Aufhängung mit 20 präzisionsgeschliffenen Rubin-Kugellagern.

Rohrtonarm: Extrem harter Titan-Rohrtonarm mit spezieller Nitrierungs-Oberflächenbehandlung.

Effektive Länge: 250 mm

Gesamtbereich: 322 ~ 350 mm

Armrückendbereich: 36,5 ~ 94,5 mm

Höheneinstellbereich: 14 ~ 64 mm
Von der Zangenmontage-Oberfläche bis zur Rohranmitte.
Schnraubenteil: 20 mm

Überhang: 15 mm

Kropfwinkel: 21°

Horizontaler Spurfelhwinkel: +1°31' (äußere Peripherie einer 30 cm-Schalplatte)
+2°31' (äußere Peripherie einer 30 cm-Schalplatte)

Mechanischer Widerstand: 5 mg (horizontal und vertikal)

Effektive Masse: 22 g (bei 6,5 g Tonabnehmergewicht, 1,25 g Auflagekraft)

Resonanzfrequenz: 9,8 Hz (bei 6,5 g Tonabnehmergewicht, 1,25 g Auflagekraft),
12 x 10⁻⁶ cm/dyn (Nachgiebigkeit)

Spitzer Resonanzwinkel (Q): 6 dB oder weniger (bei optimaler Einstellung)

Dämpfungs-Einstellbereich

Dämpfungswähler-Skalawert	Tonabnehmer-Nachgiebigkeit (100 Hz-Dynamik)
4 ~ 5	mehr als 15 x 10 ⁻⁶ cm/dyn
2 ~ 4	10 ~ 15 x 10 ⁻⁶ cm/dyn
1 ~ 2	5 ~ 10 x 10 ⁻⁶ cm/dyn

Aufgelegedruck-Einstellbereich: 0 ~ 2 g

Tonarmkopf-Gewicht: 3,5 g (Bore + Aluminium)

Tonabnehmer-Einbaunorm: 12,7 mm Einbaunorm

Tonarmkopf-Steckerstifte: 1,2 mm Ø, für 4-Stift-Kontakt

Tonabnehmer-Gewichtsbereich: 5 ~ 10 g

Tonarm-Montageöffnung: 62 mm Ø

Gleichstrom-Widerstand der Tonabnehmer-Ausgangsdrähte: 39 mΩ/m

Kapazität der Tonabnehmer-Ausgangsdrähte: 41 pF/m

Français

Spécifications

Les spécifications sont susceptibles d'être modifiées sans préavis.
Le poids et les dimensions donnés sont approximatifs.

Typ: Bras de lecture universel avec système d'amortissement dynamique réglable.

Coussinets: Type de suspension à la cardan avec 20 coussinets à billes à rubis taillés avec précision.

Bras de lecture tubulaire: Titane de bore

Longueur effective: 250 mm

Portée hors tout: 322 ~ 350 mm

Portée de l'arrière du bras: 36,5 ~ 94,5 mm

Portée de réglage de la hauteur: 14 ~ 64 mm
à partir de la surface d'installation du socle au centre du tube (partie hélicoïdale: 20 mm)

Décentrage: 15 mm

Angle de décalage: 21°

Angle d'erreur de piste horizontal: +1°31' (périmètre interne d'un disque de 30 cm)
+2°31' (périmètre extérieur d'un disque de 30 cm)

Friction: 5 mg (horizontalement et verticalement)

Masse réelle: 22 g (à un poids de cellule de lecture de 6,5 g, ek à une force d'appui de la pointe de 1,25 g)

Fréquence de résonance: 9,8 Hz (à un poids de cellule de lecture de 6,5 g, ek à une force d'appui de la tête de 1,25 g, élasticité acoustique de 12 x 10⁻⁶ cm/dyne)

Angle aigu de résonance (Q): 6 dB ou moins (à un réglage optimum)

Plage de réglage de l'amortissement

Etaonnages du sélecteur d'amortissement	Elasticité acoustique de la cellule de lecture (à 100 Hz dynamique)
4 ~ 5	plus de 15 x 10 ⁻⁶ cm/dyne
2 ~ 4	10 ~ 15 x 10 ⁻⁶ cm/dyne
1 ~ 2	5 ~ 10 x 10 ⁻⁶ cm/dyne

Plage de réglage de la force d'appui: 0 ~ 2 g

Poids de la coque porte-cellule: 3,5 g (bore + aluminium)

Dimensions du montage de la cellule de lecture: 12,7 mm (1/2 pouce) espace de montage

Pièce polaire de la coque porte-cellule: Ø 1,2 pour une borne à broche tétrapolaire

Plage du poids de la cellule de lecture: 5 ~ 10 g

Orifice d'installation du bras: Ø 62 mm

Résistance C.C. des câbles de sortie pick-up: 39 mΩ/m

Capacité des câbles de sortie pick-up: 41 pF/m

Español

Especificaciones

Las especificaciones dadas pueden sujetas a cambios sin previo aviso.
El peso y las dimensiones indicados son aproximativos.

Typo: Brazo sonoro universal con sistema de amortiguamiento dinámico variable.

Cojinetes: Suspensión cardánica con 20 cojinetes de bolas de rubies precisamente pulimentadas.

Brazo sonoro tubular: Brazo sonoro tubular de titanio de alta resistencia con acabado nitrificador especial.

Longitud efectiva: 250 mm

Alcance total: 322 a 350 mm.

Alcance posterior del brazo: 36,5 a 94 mm.
Desde la superficie de instalación de la base al centro del tubo (Parte helicoidal: 20 mm)

Parte saliente: 15 mm.

Angulo de descentramiento: 21°

Angulo de error de seguimiento horizontal: +1°31' (perímetro interno de un disco de 30 cm)
+2°31' (perímetro externo de un disco de 30 cm)

Fricción: 5 mg (en sentido horizontal y vertical)

Masa efectiva: 22 g (con el peso del cartucho en 6,5 g., presión de aguja en 1,25 g.)

Frecuencia de resonancia: 9,8 Hz (con peso de cartucho en 6,5 g., presión de aguja en 1,25 g., rendimiento de régimen de 12 x 10⁻⁶ cm/din)

Angulo de resonancia agudo (Q): 6 dB o menos (en ajuste óptimo)

Radio de ajuste de amortiguamiento

Calibraciones del selector de amortiguamiento	Rendimiento del cartucho (dinámico de 100 Hz)
4 ~ 5	más de 15 x 10 ⁻⁶ cm/dina
2 ~ 4	10 ~ 15 x 10 ⁻⁶ cm/dina
1 ~ 2	5 ~ 10 x 10 ⁻⁶ cm/dina

Radio de ajuste de la presión de la aguja: 0 a 2 g

Peso de la cápsula de la cabeza: 3,5 g (Bore + aluminio)

Dimensiones de montaje del cartucho: Espacio de montaje de 12,7 mm (1/2 pulgadas)

Lengüeta del terminal de la cápsula de la cabeza: Terminal para 4 patillas, de 1,20

Radio de peso del cartucho: Entre 5 y 10 g.

Agujerito para la instalación del brazo: 62 mm Ø

Resistencia de C.C. de los cables de salida PU: 39 mΩ/m

Capacidad de los cables de salida PU: 41 pF/m

REPLACEMENT PARTS LIST

Notes: 1. Part Numbers are indicated on most mechanical parts. Please use this parts number for parts order.
2. The "S" mark is service standard parts and may differ from production parts.
3. The parenthesized numbers in the column of description stand for the quantity on set.

REF. No.	Part No.	Description	Ref. No.	Part No.	Description	Ref. No.	Part No.	Description
1	SFPC01M201R	Headshell (With Cursor)	A1	SFPR2B50004	PU Output Cord	A16	SFPC01M201	Net. Cart. Bag
1.1	SFPAK310001	Cursor	A3	SFPGM50004	Rubber Cushion	A17	SFPR2B50004	Weight. Cart. Bag
2	SFPAM1M201R	Tonarm	A4	SFPEW50001	Mounting Plate	A18	AK1250010	Weight. Cart. Bag
3	SFPWG1M201E	With Arm Base	A5	SFPR2B50025K	Gauge	PACKING PARTS		
4	SFPR1M201E	Balance Weight	A6	SFPR2B60011	Template	P1	SFPHH1M201E	Carton Box
5	SFPR1M201E	Arm Lift	A7	SFPCB10002	Cover	P2	SFPHH1M201E	Case, Top
6	SFPR1M201K	Arm Rest	A8	SIXSN4166BNS	Screw, #1 x 16 (2 Arm Base)	P3	SFPHH1M201E	Case, Lower
7	SFPCB1M201	Speaker Arm Rest	A9	SIXSN4120BNS	Screw, #1 x 20 (4 m Panel)	P4	SFPR1M201E	Polyethylene Bag
8	SX1M3421JFZ	Screw, #2 x 10, Arm Rest	A10	SIXSN4125BNS	Screw, #1 x 25 (Arm Panel)	P5	SFPC01M201	Instruction Book and PU Output Cord
9	SFPE1M201E	Screw, Arm Lift	A11	SIXSN4125BNS	Screw, #1 x 25 (Arm Panel)	P6	SFPR1M201E	Polyethylene Bag
10	SFPE1M201E	Nut, Arm Lift	A12	SIXKWA4R	Cushion, #4 (Arm Panel)	P6	SFPR1M201E	Polyethylene Bag, Base
11	SFPGM10005	Rubber, Screw of Arm Lift	A13	KWG4E10BN	Washer, #4 (Arm Panel)	P7	SFPR1M201E	Polyethylene Bag, Arm
12	SFPE1M201	Screw, Balance Weight	A14	SFPR1M201E	Screw, Cart. Bag	P8	SFPHH1M201E	Sheet, Case and Plate
			A15	SFPR1M201E	Screw, Cart. Bag	P9	SFPR1M201E	Sheet, Case and Plate
			A15	SFPR1M201E	Screw, Cart. Bag	P9	SFPR1M201E	Sheet, Case and Plate
			A15	SFPR1M201E	Screw, Cart. Bag	P9	SFPR1M201E	Sheet, Case and Plate

EPA-100MK2

■ EXPLODED VIEW

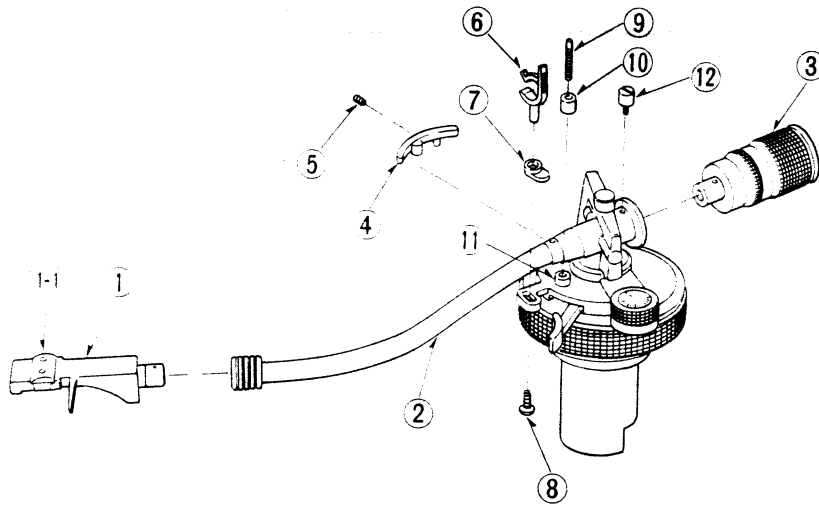

Service Manual

Turntable Base/Dust Cover
SH-10B5

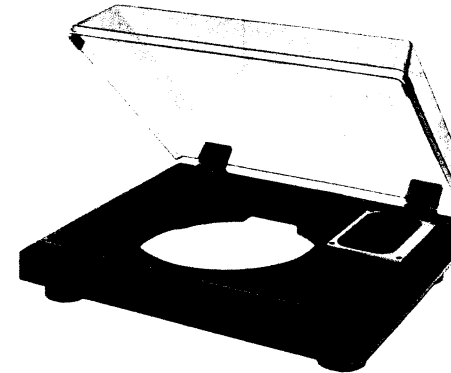

Specifications

External dimensions (W x H x D): 56,1 x 17,5 x 46,3 cm
[Maximum height when top (dust cover) is open 48 cm]
Weight: 19 kg
(Including dust cover, Except for arm panel)
Specifications subject to change without notice.
Weight and dimensions shown are approximate.

TECHNISCHE DATEN

Äußere Abmessungen (B x H x T): 56,1 x 17,5 x 46,3 cm
[Maximale Höhe bei vollständig geöffneter Staubabdeckung: 48 cm]
Gewicht: 19 kg
(Einschließlich Staubabdeckung), Ohne Tonarmplatte.)
Änderungen der technischen Daten vorbehalten.
Die angegebenen Gewichts- und Abmessungsdaten sind ungefähre Werte.

Spécifications

Dimensions externes (L x H x P): 56,1 x 17,5 x 46,3 cm
[Hauteur maximum lorsque le dessus (couvercle protège-poussière) est ouvert 48 cm]
Poids: 19 kg
(Couvercle anti-poussière compris, Excepté pour la plaque du bras.)

Les spécifications sont susceptibles d'être modifiées sans préavis.
Le poids et les dimensions données sont approximatifs.

Especificaciones técnicas

Dimensiones externas: 56,1 x 17,5 x 46,3 cm
(Ancho x alto x profundo) [Altura máxima cuando la parte de arriba (tapa contra el polvo) está abierta 48 cm]
Peso: 19 kg
(Incluyendo la tapa contra el polvo, Excepto para el tablero del brazo.)

Las especificaciones quedan sujetas a cambios sin aviso previo.
El peso y las dimensiones indicadas son aproximadas.

Technics

SH-10B5

REPLACEMENT PARTS LIST

- Notes:**
1. Part numbers are indicated on most mechanical parts. Please use this part number for parts order.
 2. Bracketed indications in Ref. No. columns specify the area. Parts without these indications can be used for all areas.
 3. The "S" mark is service standard parts and may differ from production parts.
 4. The parenthesized numbers in the column of description stand for the quantity pre-set.

Ref. No.	Part No.	Part Name & Description	Ref. No.	Part No.	Part Name & Description
CABINET PARTS					
1	SFAD103-01	Dust Cover (1)	8	SFGA106N01A	Insulator/Leg (4)
2	SFUP103-02	Hinge (Dust Cover Side)			
3	SFUP103-03	Bracket, Hinge (Dust Cover Side)	SCREWS and WASHERS		
4	SFGZ106N03	Rubber Cushion	N1 S	EN4-12BVS	Screw, ϕ 4 x 12 (4)
5	SFAD106N01R	Cap net	N2 S	EN4-12S	Screw, ϕ 4 x 12 (2)
6	SFGA106N01A	Hinge (Cabinet Side)	N3 S	WASB	Washer, ϕ 5 (2)
7	SFUP106N01	Bracket, Hinge (Cabinet Side)	N4	TV3+25TF2	Screw, With washer, ϕ 3 x 25 (4)

EXPLODED VIEW

