

Service Manual

Panasonic
PLAYER UNIT
Panasonic



MODEL **SL-1100**

SPECIFICATIONS

TURNTABLE SECTION

Type :	Direct drive player system
Turntable Platter :	Aluminium die-cast; 35 cm (13-25/32") diameter 320 kg-cm ² (109.5 lb-in ²) inertial moment, 2 kg (4.4 lb) weight
Turntable Speeds :	33-1/3 and 45 r.p.m.
Motor :	20 poles (rotor) -15 poles (stator) ultra low-speed electronically commutated motor
Power Supply :	60 Hz, 120 V, 4 W
Speed Change Method :	Electronical change
Variable Pitch Control :	Individual adjustment by variable resistor, $\pm 5\%$ adjustment range
Wow and Flutter :	Less than 0.03% WRMS
Rumble :	Better than 65 dB (DINA), 70 dB (DINB)
Build-up Time :	Within 1/2 rotation at 33-1/3 r.p.m.
Dimensions :	(W) 51.0 cm \times (D) 39.0 cm \times (H) 19.5 cm (20-5/64" \times 15-23/64" \times 7-43/64")
Weight :	13.0 kg (28.7 lb) with Dust Cover
Player Case :	Aluminium die-cast with audio insulated legs

TONARM SECTION

Type :	EPA-110 Directly reading stylus pressure, static-balanced type, with pipe arm universal head shell, anti-skating force device.
Effective Length :	235 mm (9-1/4")
Overhang :	14 mm (35/64")
Tracking Error Angle :	Within $\pm 1.75^\circ$
Stylus Pressure :	0-5 g

(Specifications, design and other details are subject to change, without prior notice, at any time in order to improve performance.)

MATSUSHITA ELECTRIC CORP. OF AMERICA
MATSUSHITA ELECTRIC OF HAWAII, INC.
MATSUSHITA ELECTRIC OF CANADA LTD.

ORDER NO. SD-334

Pan-Am Bldg., 200 Park Ave., New York, N.Y. 10017
320 Waiakamilo Road, Honolulu, Hawaii 96817
40 Ronson Drive, Rexdale, Ont.

CIRCUITRY AND OPERATION PRINCIPLES

The control circuitry of the motor in this set consists of the following circuits; the oscillation circuitry which generates the input signal of the position detecting section; the switching circuitry which controls the current of the armature (stator core) winding by the output signal of the position detecting section; and the speed control circuit, which detects the voltage generated in the speed generator winding in proportion to the rotation of the motor and keeps the motor speed constant.

In addition, a DC stabilized power supply is included in order to supply power to each assembly.

BLOCK DIAGRAM OF DIRECT DRIVE PLAYER SYSTEM

- The oscillation circuitry generates a high-frequency signal of about 50 kHz and supplies it to primary coils W111, W121 and W131 of the position detecting section.
- The position detecting rotor of the position detecting section changes, by rotating, the coupling degree between primary coils W111, W121 and W131 of the position detecting section and the secondary coils (W112, W122 and W132) of the same section.
- As shown in the figure, the coupling between W111 and W112 is the closest, and that between W121 and W122 is less.
- The high-frequency signal mentioned above is induced to the secondary coil of the closely-coupled section.
- The high-frequency voltage thus induced is rectified by diodes D1, D2, and D3, and, as the position signal, controls transistors TR1, TR3 and TR5 of the switching circuitry.
- Power transistors TR2, TR4 and TR6 are controlled by TR1, TR3 and TR5. As shown in the figure, the high-frequency signal which is generated in W112 is rectified by D1 and this voltage is applied to TR1, making TR2 in the condition of continuity.
- By the three circuitry-continuity/breaking actions of power transistors TR2, TR4 and TR6, current flows through drive windings W211, W231 and W221 of the armature section, and power for rotation is generated between the armature and the magnet rotor.
- Speed generation windings W212, W222 and W232 are wound on the drive winding and bifilar, and they generate three-phase AC voltage which has an amplitude proportionate to the speed. This voltage is rectified by diodes D4, D5 and D6, and DC voltage E_a , which is proportionate to the speed, is obtained.
- Comparing this speed voltage (E_a) with the standard voltage (E_s) from the standard voltage section in the voltage stabilization circuitry, which is determined corresponding to the necessary rotation speed, adjustment is made of the current which flows through the power transistors of the switching circuitry. In other words, if the speed is faster than the specified speed, the current decreases and the speed becomes slower. If the speed is slower than specified, the current increases and the speed increases. In this way, the speed is stabilized.
- The speed change and adjustment are made by changing the resistance of the circuitry (that is by changing the standard voltage) which compares the standard voltage with the speed voltage.

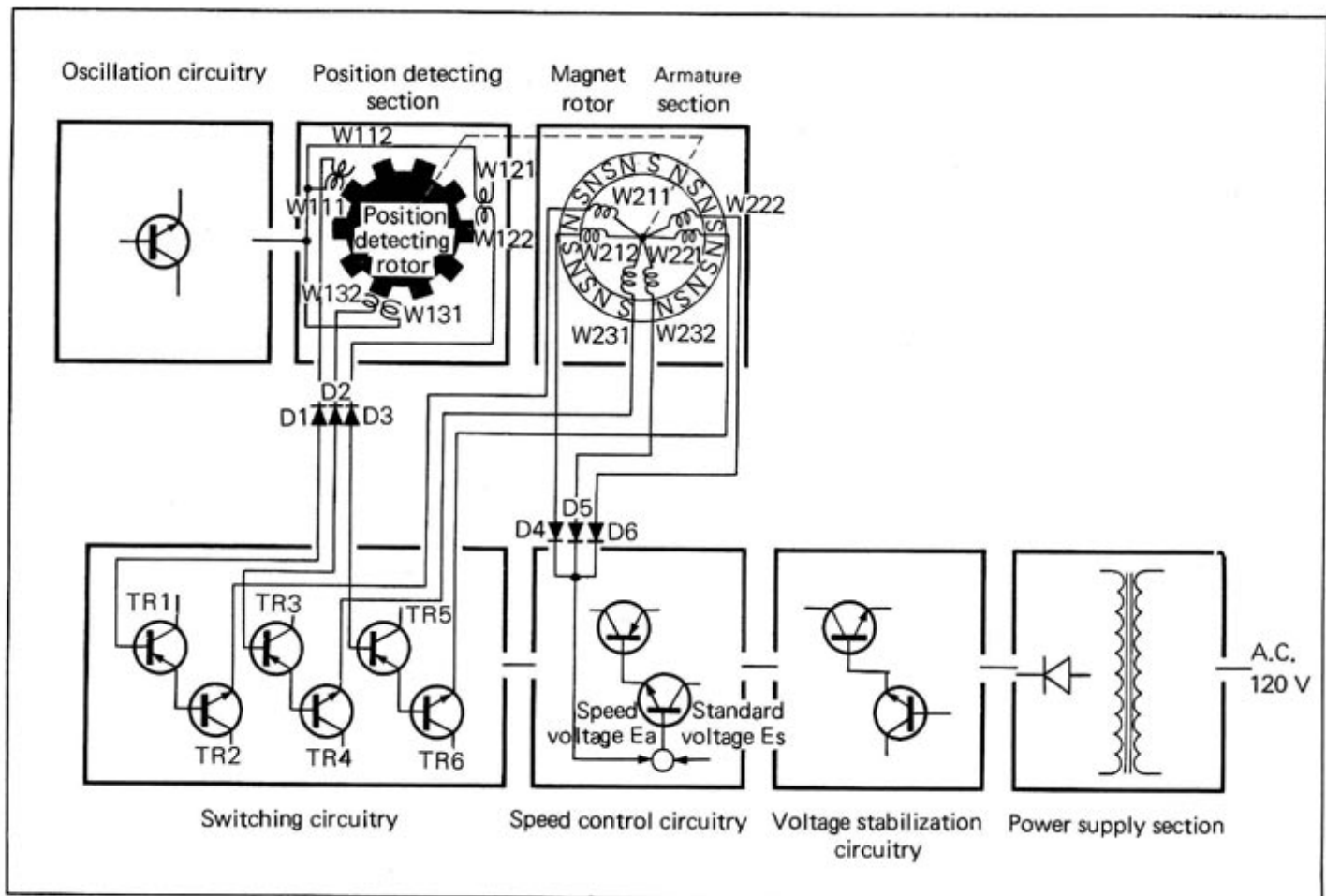

Head Shell

Insert the head shell in the end of the tonearm, and secure firmly by turning the locking nut of the tonearm in the direction of the arrow, as shown in the picture. Be sure to connect the lead wires to the cartridge terminals according to the instructions included with the cartridge.

The cartridge should be inserted in the head shell so that the spacing between the stylus tip and the plug is 52 mm (2-1/16") as shown in the picture.

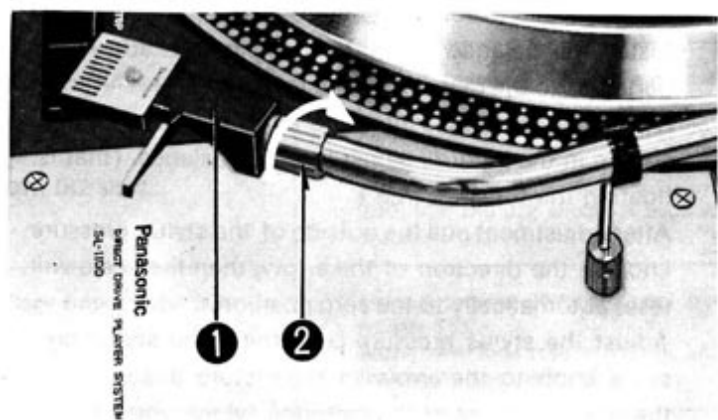

Locking Nut Fig. 1

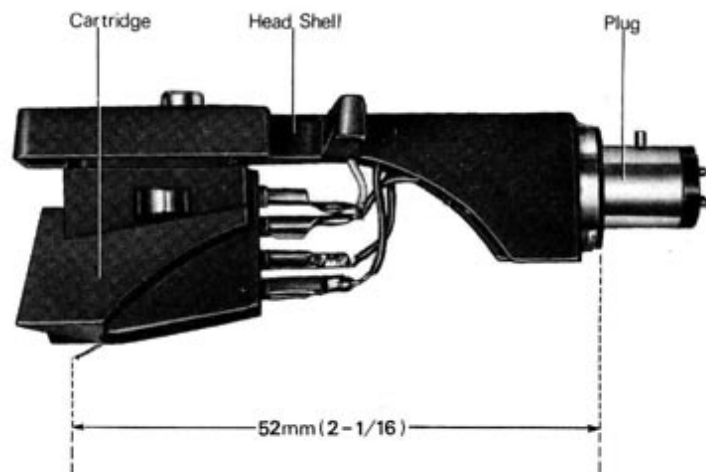

Fig. 1

Anti-skating Force Device Fig. 2

Skating force is that frictional force caused by contact between the tip of the stylus and the record groove, and is applied to the stylus as a side pressure depending upon the relationship of the geometrical position of the tonearm.

This force results in an unbalance of the contact pressure between the stylus tip and the sound grooves of the record, an increase of distortion, a deterioration of the performance, a decrease of separation characteristics and abnormal wear of the stylus tip.

For this reason, it is necessary to compensate for ("cancel") this outside force.

The outside force device mechanism performs this compensation function.

The quantity of outside force is in proportion to the stylus pressure and, therefore, outside force should be adjusted according to the stylus pressure.

Turn the adjustment knob, as shown in the picture, to the same quantity as stylus pressure scale indicates.

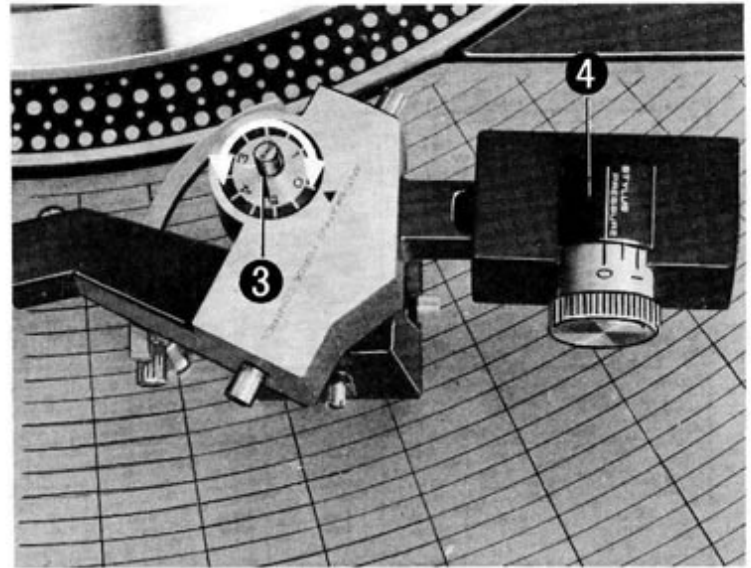

Fig. 2

Balance Weight Fig. 3

This balance weight is especially designed for easy adjustment of zero balance.

In addition, all functions are built-in on the upside of the tonearm such as anti-skating force control and stylus pressure control, therefore, operation is easy. Install the balance weight which is packed in the parts box to the rear side of the tonearm.

By turning the stylus pressure knob to the arrow, as shown in the picture, adjust the zero balance. (that is, floating the tonearm free.)

After adjustment pull the outside of the stylus pressure knob in the direction of the arrow, then the scale will reset automatically to the zero position.

Adjust the stylus pressure by turning the stylus pressure knob to the arrow in the picture according to the stylus pressure of the cartridge which you use.

If the cartridge weight is beyond 9.5 g use the auxiliary weight which is packed in the parts box, as shown in the picture.

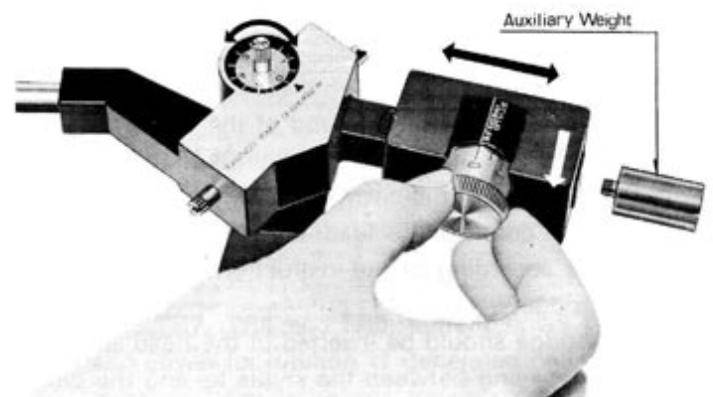
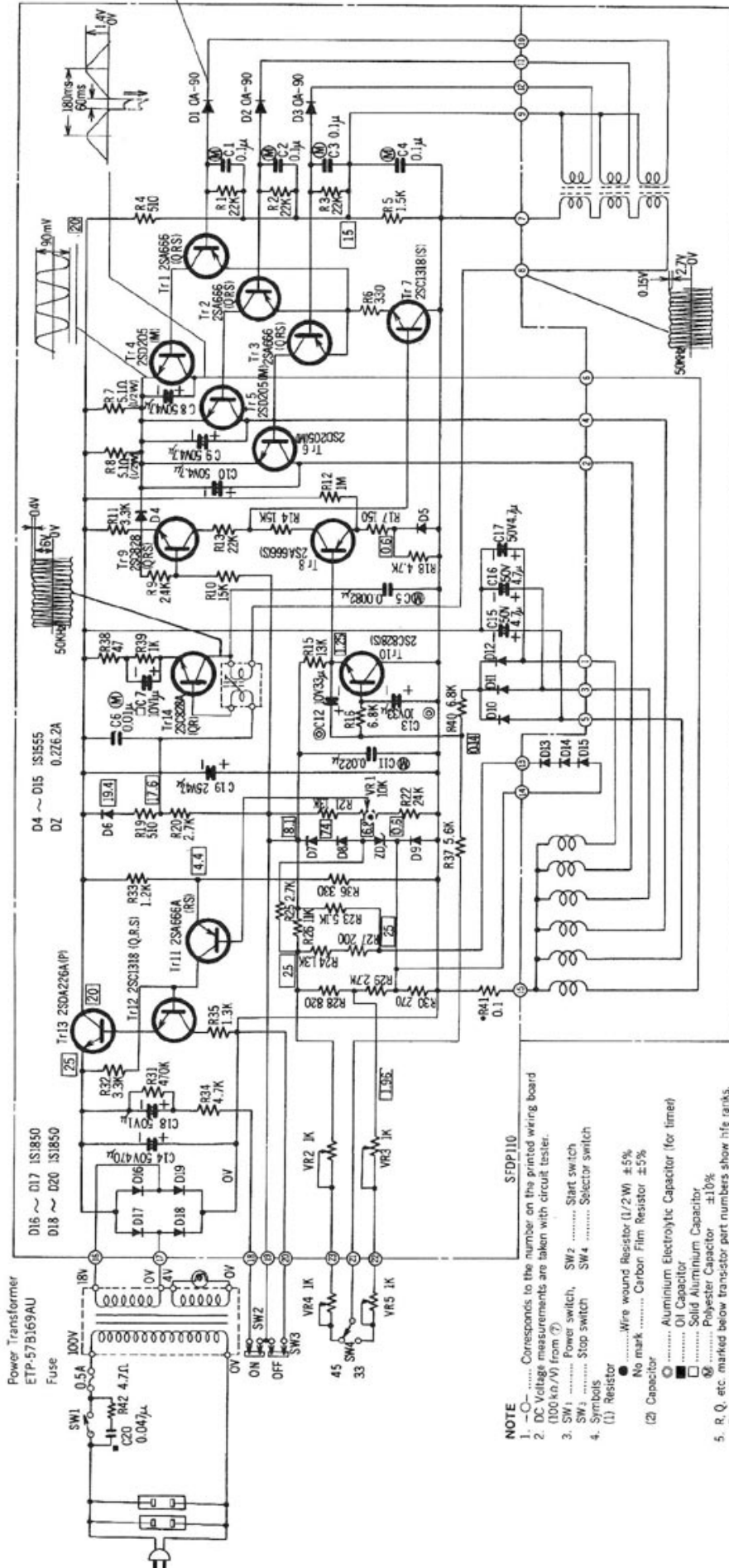

Fig. 3

SCHEMATIC DIAGRAM

MODEL SL-1100



CIRCUIT BOARD

MODEL SL-1100

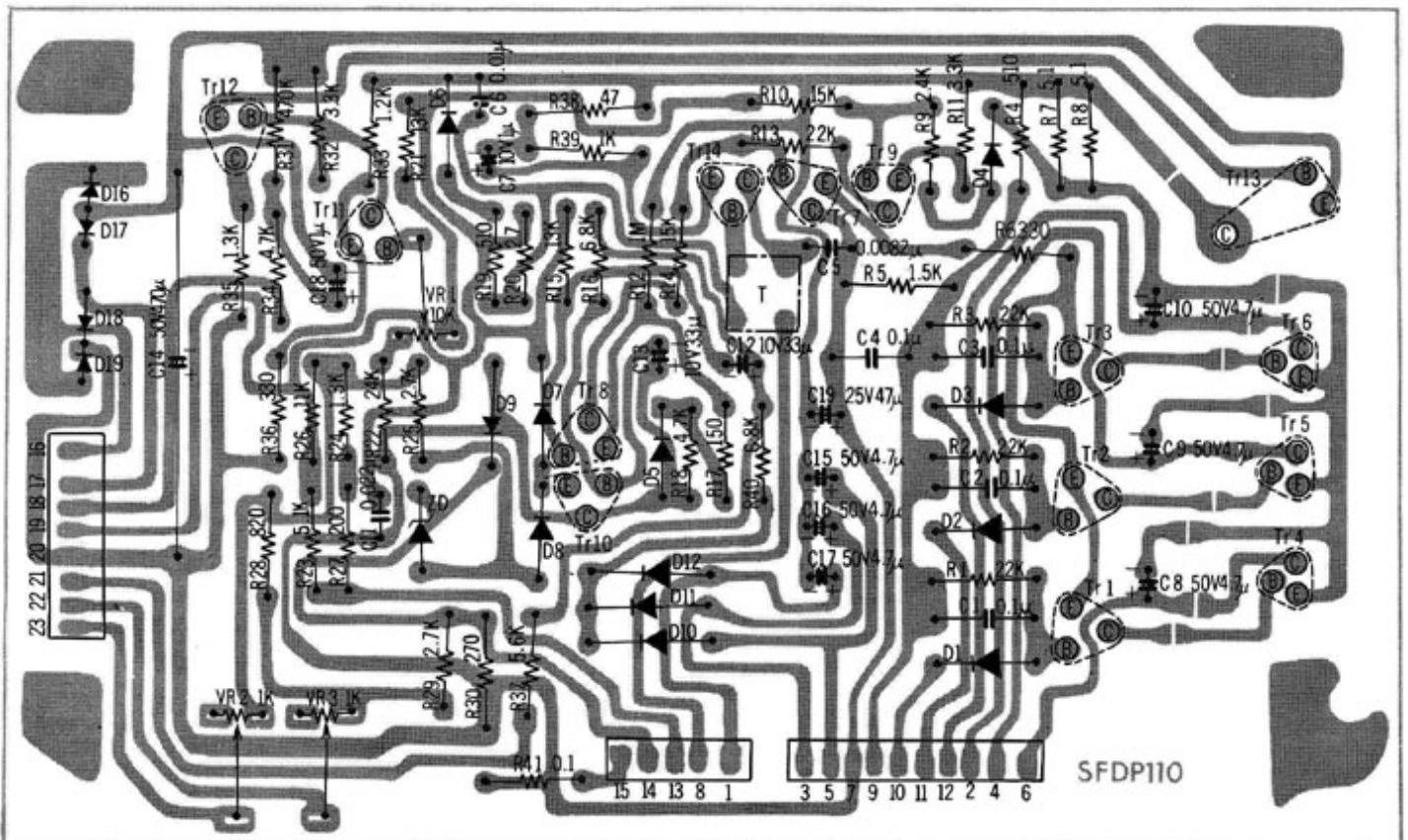
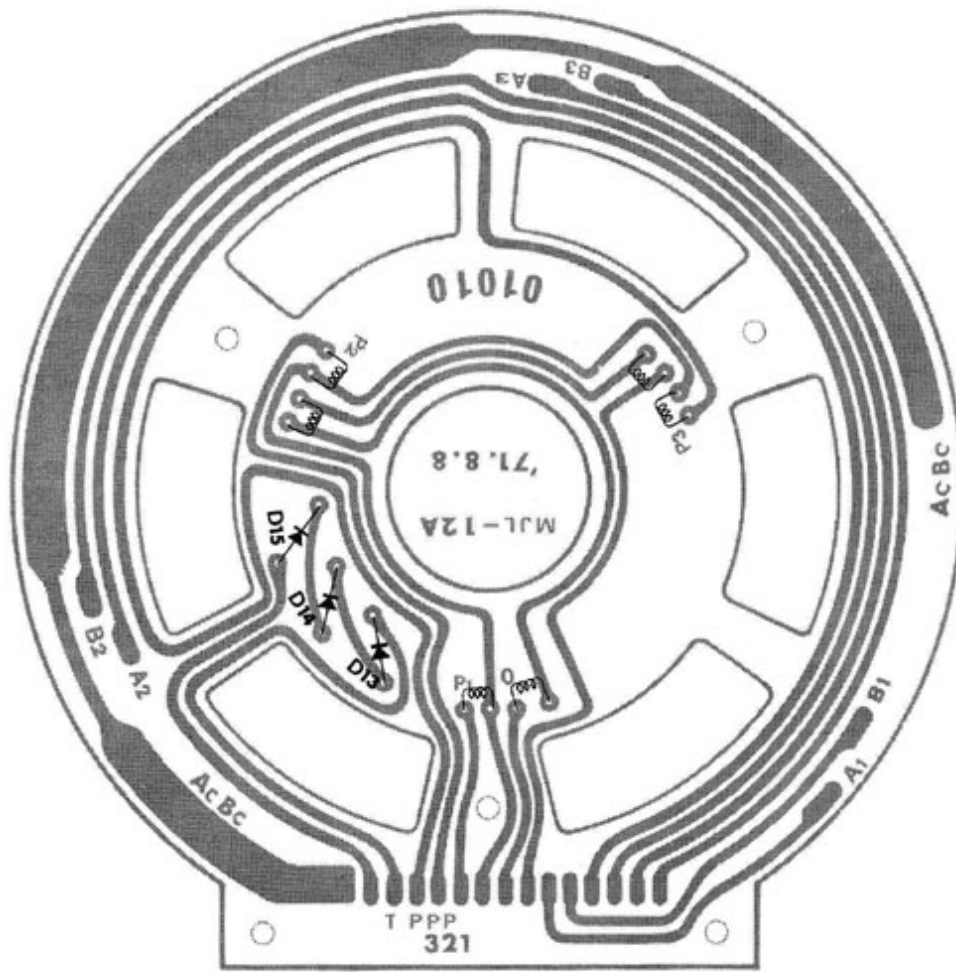

TROUBLE SHOOTING GUIDE

★ Except when checking voltage, disconnect the power cord before repair without fail.

TROUBLE	CAUSE	REMEDY
<p>Turntable Speed</p> <p>A. Switching on does not cause turntable to rotate.</p>	<p>Remove back cover and, using DC voltmeter, check printed base voltage :</p> <ol style="list-style-type: none"> 1. No output of constant-voltage circuit (between Tr13 collector and (7)) is found. <ol style="list-style-type: none"> (1) No output on secondary of transformer. <ul style="list-style-type: none"> • Cord disconnected. • Soldered improperly. • Fuse disconnected. • Power transformer defective. (2) Output found on secondary of transformer. <ul style="list-style-type: none"> • Constant-voltage circuit parts (ZD1, Tr11, Tr12, Tr13) defective. 2. Output of constant-voltage circuit is not 20V. <ul style="list-style-type: none"> • VR1 defective. • Diode D7, D8, D9, ZD shorted. 3. Output of constant-voltage circuit is 20V. <ul style="list-style-type: none"> • 3-phase switching circuit (Tr1~Tr6), oscillator circuit (Tr14) defective. 4. Power switch is not ON. <ul style="list-style-type: none"> • Micro switch defective. 5. Speed selector switch defective. <ul style="list-style-type: none"> • Contact faulty • Soldered improperly. 	<ul style="list-style-type: none"> • Replace cord. • Solder securely • Replace fuse. • Replace power transformer. <ul style="list-style-type: none"> • Replace printed base assembly. <ul style="list-style-type: none"> • Replace and adjust semi-fixed resistor VR1 on printed base, so that output of constant-voltage circuit (between TR13 collector and (7) becomes 20V. • Replace printed base assembly. <ul style="list-style-type: none"> • Replace printed base assembly. <ul style="list-style-type: none"> • Adjust switch mechanism. • Replace micro switch. <ul style="list-style-type: none"> • Replace speed selector switch. • Solder securely.
<p>B. Turntable speed too fast</p>	<ul style="list-style-type: none"> • Constant-voltage output is not 20V. • Speed maladjusted • Diode D10, D11, D12 short. 	<ul style="list-style-type: none"> • Make it become 20V with semifixed resistor VR1. • Adjust semi-fixed resistor VR2 or VR3 for rough adjustment. • Replace printed base assembly. (D10, D11, and D12 should be equal in characteristic.)
<p>C. Turntable speed too slow.</p>	<ul style="list-style-type: none"> • Constant-voltage output is not 20V. • Speed unadjusted. 	<ul style="list-style-type: none"> • Make it become 20V with semi-fixed resistor VR1. • Adjust semi-fixed resistor VR2 or VR3 for rough adjustment.
<p>D. Turntable speed varies too much.</p>	<ul style="list-style-type: none"> • Trouble in 3-phase switching circuit. 	<ul style="list-style-type: none"> • Replace printed base assembly.
<p>E. Turntable, after stopped by hand, will not turn or starts turning but will stop soon.</p>	<ul style="list-style-type: none"> • 3-phase switching circuit defective. 	<ul style="list-style-type: none"> • Replace printed base assembly.
<p>F. Operative at only one of two speeds (33 1/2 rpm, 45 rpm)</p>	<ul style="list-style-type: none"> • Selector switch defective. • Lead disconnected or unsoldered. • Contact of VR2, VR3 insufficient. 	<ul style="list-style-type: none"> • Replace selector switch. • Replace lead, or solder securely. • Replace printed base assembly.
<p>Noise</p> <p>Offensive noise is heard.</p>	<ul style="list-style-type: none"> • Power transformer makes loud noise of vibration. • Broken part of rotor magnet or iron chips attracted by magnet and rubbed by motor case. 	<ul style="list-style-type: none"> • Replace power transformer. • Replace motor.

SPARE PARTS LIST

Ref. No.	Part No.	Description	Per Set (Pcs.)	Ref. No.	Part No.	Description	Per Set (Pcs.)
1	SFTG110	Turntable Mat	1	15-6	SFKU040-1A	Arm Rest Ass'y	1
2	SFTE110-01A	Turntable Plattes Ass'y	1	15-7	SFKU040-2	Arm Rest Boss	1
3	MJL-12A	Motor Ass'y	1	15-8	XWC8AFU	Toothed Lock Washer	1
3-2	XSN4+15FC	Screw (for Motor)	4	15-9	XNG8JFU	Nut	1
3-3	XWA4BFM	Spring Washer (for Motor)	4	15-10	SFXJ110-3E	Arm Lift Operation Lever Ass'y	1
3-4	XNG4JFC	Nut (for Motor)	4	15-11	SFKR110-1A	Arm Lift Operation Ass'y	1
4	SFAC110	Player Case	1	15-12	XWA3BFM	Spring Washer (for Main Switch Ass'y)	8
5	SFUP110-1	Supporting Plate	4	15-13	XSN3+6FU	Screw (for Main Switch Ass'y)	8
5-2	XWA4BFM	Spring Washer (for Supporting Plate)	11	15-14	SFER6A-A	PU Terminal Strip Ass'y	1
5-3	XSN4+8FZ	Screw (for Supporting Plate)	11	16	EPA-110B	Tonearm Ass'y	1
6	SFUK110X01A	Main Switch Ass'y	1	16-2	SFP-KD11001	Tonearm Base	1
6-2	XWA3BFM	Spring Washer (for Main Switch Ass'y)	3	16-3	SFP-WG11001K	Balance Weight	1
6-3	XSN3+6FU	Screw (for Main Switch Ass'y)	3	16-4	SFP-WG11002	Auxiliary Weight	1
6-4	SFKT110-5	Power Switch/Speed Selectar	1	16-5	SFP-CC11002K	Head Shell Ass'y	1
6-5	SFKT110-4	Variable Pitch Control Knob	2	16-6	XWA4BFM	Spring Washer (for PU output Terminal Ass'y)	1
7	SFUP110M02A	AC Terminal Strip Ass'y	1	16-7	XSN4+12FU	Scrcw(for PU output Terminal Ass'y)	1
7-2	XWA4BFM	Spring Washer (for Main Switch Ass'y)	2		SFDH110	PU Cord	1
7-3	XSN4+6FU	Screw (for Main Switch Ass'y)	2		SFWE010	45 r.p.m. Adaptor	1
8	SFDP110-A	Printed Wiring Base Ass'y	1		SFW0010	Special Oil (for Lubricating)	1
8-2	XSN3+6FU	Screw (for Main Switch Ass'y)	5		SPNU110M01	Printed Matter	1
9	SFUK110X05A	Output Terminal Ass'y	1	PACKING MATERIALS			
9-2	XWA4BFM	Spring Washer (for Main Switch Ass'y)	3				
9-3	XSN4+6FU	Screw (for Main Switch Ass'y)	3	P1	SFHP110M01	Inside Packing Case	1
10	SFUP110M01A	Tranformer Mounting Board Ass'y	1	P2	SFHD110-01	Turntable Pad	1
10-2	SFX0850-1	Spacer (for Main Switch Ass'y)	4	P3	SFYF45A50	Polyethylene Pack	1
10-3	SFXW750-1	Washer (for Main Switch Ass'y)	4	P4	SFHH110-06	Accessory Box, Lid	1
10-4	XWA3BFM	Spring Washer (for Main Switch Ass'y)	4	P4-1	SFHH110-07	Accessory Box, Bottom	1
10-5	XSN3+25FU	Screw (for Main Switch Ass'y)	4	P5	SFHH110-8	Side Pad	2
11	SFUK110-1A	Start Stop Button Ass'y	1	P5-1	SFYC100A130	Polyethylene Sheet	1
11-2	XWA3BFM	Spring Washer (for Main Switch Ass'y)	2	P6	SFHK100-1	Supporting Base for Tonearm	1
11-3	XSN3+6FU	Screw (for Main Switch Ass'y)	2	P7	XSN3+6FUB	Screw	4
12	1277	AC Outlet	1	P7-1	FU-PWF003	Washer	4
13	SFUZ110-3A	Audio-insulated Leg Ass'y	4	P7-2	SFXG110-1	Rotor Clamping Fitting	2
14	SFUP110M03A	Bottom Cover Ass'y	1	P8	SFHZ100-2	Protection Sheet for Dust Cover	1
14-2	XWA4BFM	Spring Washer	9	P9	SFHP110-01	Player Case	1
14-3	XSN4+8FZ	Screw	9	P10	SFWK040L	Wanishing Cloth	1
14-4	SFUZ110-9	Bottom Cover Supporting Bar	1	P10-1	RQX9028A	Servicenters	1
	SFAD110M01A	Dust Cover Ass'y	1	P10-2	SQX7009-1	Warranty Card	1
15	SFAC110M01	Arm Panel	1	P10-3	RQX9020A	Leaflet	1
15-2	SFKZ110	Screw (for Arm Panel)	8	P11	SFNU110X02	Instruction of Packing	1
15-3	SFKR110-1A	Arm Lift Ass'y	1	P12	SFHP110M02	Outside Packing Case	1
15-4	SFXB110-1	Arm Lift Boss	1				
15-5	XNG8JFU	Nut (for Arm Panel)	1				

EXPLODED VIEW OF DIRECT DRIVE PLAYER MODEL SL-1100

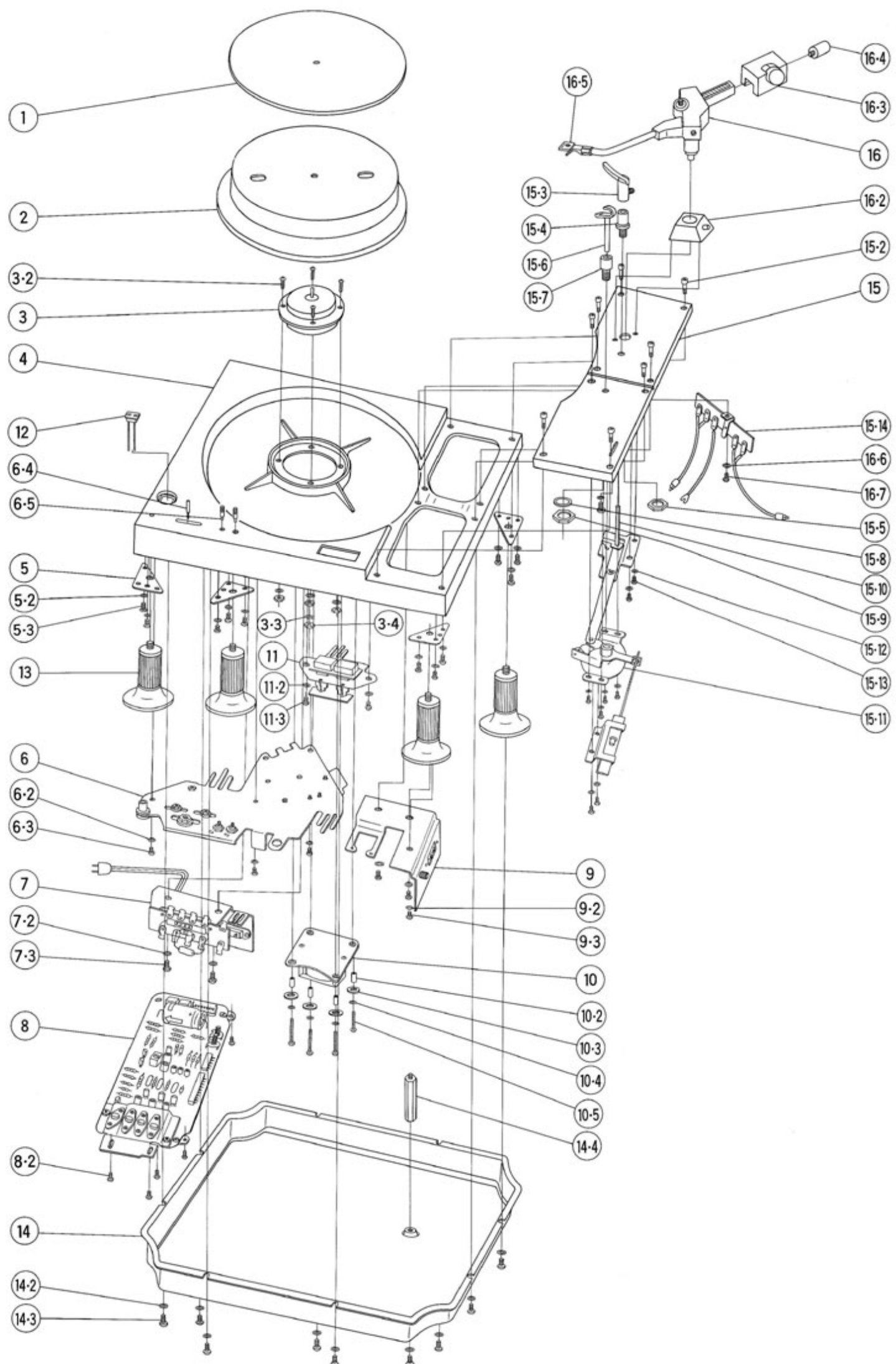

COMPONENT PACKING PROCEDURE

