

Service Manual

Direct Drive Turntable System

Turntable System

SL-1200M3D

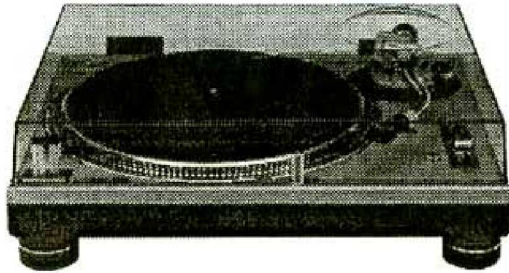

Colour

(S).....Silver Type

Areas

(P).....U.S.A.

(PC).....Canada.

■ Specifications

■ General

Power supply:	AC 120V, 60Hz
Power consumption:	14W
Dimensions (WxHxD):	453 x 162 x 353 mm (17-27/32" x 6-12/32" x 13-29/32")
Weight:	12 kg (26.4 lb.)

■ Turntable section

Type:	Quartz direct drive Manual turntable
Drive method:	Direct drive
Motor:	Brushless DC motor
Turntable platter:	Aluminum diecast Diameter 332 mm (13-5/64") Weight 1.7 kg (3.74 lb.)
Turntable speeds:	33-1/3 rpm and 45 rpm
Starting torque:	1.5 kg-cm (1.3 lb-in)
Build-up characteristics:	0.7s. from standstill to 33-1/3 rpm
Braking system:	Electronic brake
Wow and flutter:	0.01% W.R.M.S.* 0.025% W.R.M.S.(JIS C5521) ±0.035% peak (IEC 98A Weighted)
Rumble:	-56 dB (IEC 98A Unweighted) -78 dB (IEC 98A Weighted)

*This rating refers to turntable assembly alone, excluding effects of record, cartridge or tonearm, but including platter. Measured by obtaining signal from built-in frequency generator of motor assembly.

■ Tonearm section

Type:	Universal
Effective length:	230 mm (9-1/16")
Arm height adjustment range:	0 - 6 mm
Overhang:	15 mm (19/32")
Effective mass:	12 g (without cartridge)
Offset angle:	22°
Friction:	Less than 7 mg (lateral, vertical)
Tracking error angle:	Within 2°32' (at the outer groove of 30 cm <12"> record) Within 0°32' (at the inner groove of 30 cm <12"> record)
Stylus pressure adjustment range:	0 - 4 g
Applicable cartridge weight range:	11 - 20.5 g (including headshell)
(with auxiliary weight);	9.5 - 13 g 17 - 20.5 g (including headshell)
(with shell weight);	3.5 - 6.5 g 11 - 14 g (including headshell)
Headshell weight:	7.5 g

Note:

Specifications are subject to change without notice.
Weight and dimensions are approximate.

⚠ WARNING

This service information is designed for experienced repair technicians only and is not designed for use by the general public. It does not contain warnings or cautions to advise non-technical individuals of potential dangers in attempting to service a product. Products powered by electricity should be serviced or repaired only by experienced professional technicians. Any attempt to service or repair the product or products dealt with in this service information by anyone else could result in serious injury or death.

Technics®

Contents

	Page	Page	
• Safety Precaution	2	• Troubleshooting guide	11
• Accessories	2	• Operation Checks and	
• Features	3	Component Replacement Procedures ...	12-16
• Controls	3	• Schematic Diagram	17-19
• Preparation of the cartridge	3	• Printed Circuit Boards	20-22
• Putting the player together	4	• Measurements and Adjustments	23
• Connections and installation	5	• Block Diagram	24
• Preparatory adjustments	6,7	• Wiring Connection Diagram	25
• Playing records	8	• Replacement Parts List	26,27
• Adjustments while using the unit	9	• Cabinet Parts Location	28,29
• Maintenance	10	• Packaging	30
• Product service	10		

■ Safety Precaution (This "Safety Precaution" is applied only in U.S.A.)

1. Before servicing, unplug the power cord to prevent an electric shock.
2. When replacing parts, use only manufacturer's recommended components for safety.
3. Check the condition of the power cord. Replace if wear or damage is evident.
4. After servicing, be sure to restore the lead dress, insulation barriers, insulation papers, shields, etc.
5. Before returning the serviced equipment to the customer, be sure to make the following insulation resistance test to prevent the customer from being exposed to a shock hazard.

● INSULATION RESISTANCE TEST

1. Unplug the power cord and short the two prongs of the plug with a jumper wire.
2. Turn on the power switch.
3. Measure the resistance value with ohmmeter between the jumpered AC plug and each exposed metal cabinet part, such as screwheads antenna control shafts, handle brackets, etc. Equipment with antenna terminals should read between 3 MΩ and 5.2 MΩ to all exposed parts. (Fig. A)
Equipment without antenna terminals should read approximately infinity to all exposed parts. (Fig. B)

Note: Some exposed parts may be isolated from the chassis by design. These will read infinity.

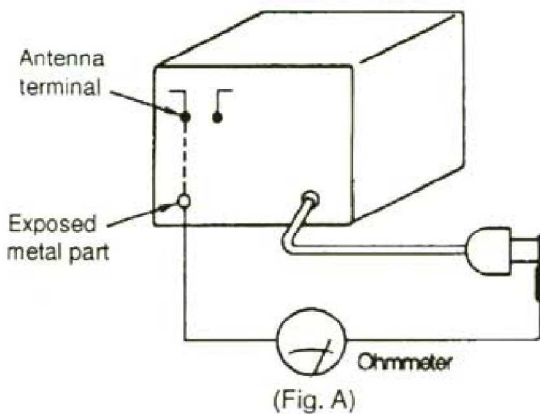

Resistance = 3 MΩ - 5.2 MΩ

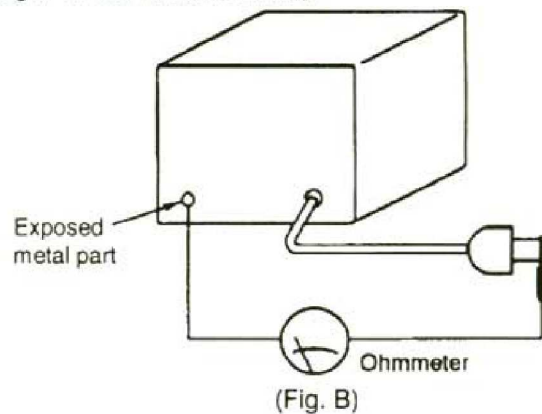

Resistance = Approx. ∞

4. If the measurement is outside the specified limits, there is a possibility of a shock hazard. The equipment should be repaired and rechecked before it is returned to the customer.

■ Accessories

(Only for U.S.A.)

To order accessories contact 1-800-332-5368 or web site (<http://www.panasonic.com>).

Turntable.....1 pc.
(SFTE172-01Z)



Dust cover.....1 pc.
(SFAD122-01A)



Auxiliary weight.....1 pc.
(SFPWG17202)



Screw set for cartridge.....1 pc.

- Nuts(RHN26003)
- Screws-short(SFCZV8801)
- Screws-long(SFPEV9801)
- Washers(SFPEW9601)

Turntable mat.....1 pc.
(RGS0008)



Shell with stylus weight
(SFPCC31005K).....1 pc.



EP record adaptor.....1 pc.
(SFEW010)



Disc slip sheet set.....1 pc.
(RGS0005Z)

- Disc slip sheet
- Transparent sheet



Balance weight.....1 pc.
(SFPWG17201K)



Shell weight.....1 pc.
(SFPZB3501)



Overhang gauge.....1pc.
(SFK0135-01)



A cartridge is not included.

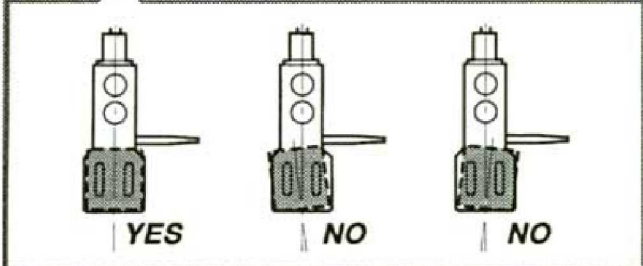
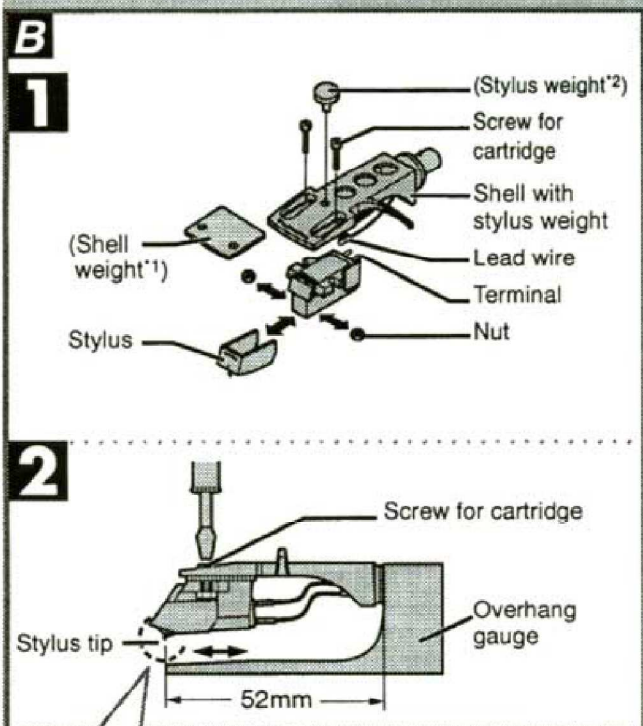
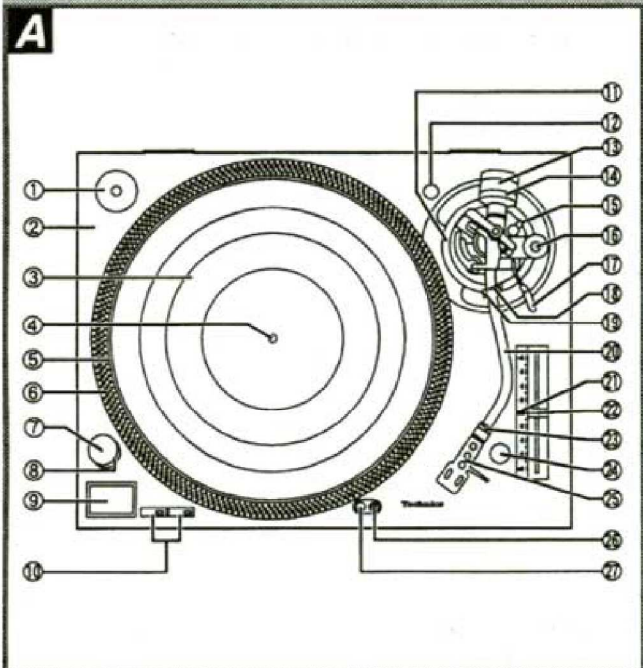

■ Features

A masterpiece amongst turntables with a worldwide reputation.

Pitch control reset button

- Pitch can be instantly reset to the rated speed (33 1/3 or 45 rpm).

Highly accurate turntable speed maintained continuously with a quartz pitch control

- The pitch can be varied between -8 and +8%, with accuracy maintained throughout the range.

The direct drive produces high torque

- Wow and flutter below 0.01%. Starting torque of 1.5 kg/cm enabling the turntable to reach 33 1/3 rpm in 0.7 seconds.

- Fully electric braking system.

Tone arm with gimbal suspension

- The tone arm can be finely adjusted in a range of 6 millimeters with the lockable height control.

Anti-vibration design with 3 layer cabinet construction and large insulating legs.

Pop-up stylus light.

■ Controls A

No.	Name	Reference page(s)
①	EP record adaptor	8
②	Turntable base	3
③	Turntable mat (Or disc slip sheet)	4
④	Center spindle	4
⑤	Turntable	4
⑥	Strobe lights	9
⑦	Power switch (power)	8
⑧	Strobe illuminator/pilot lamp	9
⑨	Start/stop button (start - stop)	8
⑩	Speed select buttons (33, 45)	8
⑪	Arm-height control	7
⑫	Shell stand	3
⑬	Balance weight	4
⑭	Stylus pressure control	6
⑮	Arm lock	7
⑯	Anti-skating control	6
⑰	Cue lever	6
⑱	Arm clamp	6
⑲	Arm rest	6
⑳	Tone arm	4
㉑	LED indicator	9
㉒	Pitch control (Pitch adj.)	9
㉓	Locking nut	4
㉔	Reset button (reset)	9
㉕	Head shell	3
㉖	Stylus light switch	8
㉗	Stylus light	8

■ Preparation of the cartridge B

1 Attach a cartridge (not included).

Follow the cartridge's instructions to correctly attach it to the head shell.

- Use the included shell weight *1 when using a light cartridge (3.5 to 6.5 grams).
- Use the stylus weight *2 to increase stylus pressure (➡ page 6). Leave it off until stylus pressure has been adjusted.

2 Adjust the overhang.

Fit the included overhang gauge to the head shell. Adjust the overhang and facing of the cartridge and tighten the screws.

- Line the point of the stylus up with the end of the gauge.
- The cartridge should be parallel on the shell head.

■ Putting the player together

Put the player together in the following order.

- Do not connect the AC power cord until set up is complete.
- Leave the dust cover off until set up and adjustments are complete.

1 Fit the turntable ① and turntable mat ②.

- Put the turntable on the center spindle and then lay the mat on top.
- Be very careful when putting the turntable on the main unit. The magnet on the bottom of the turntable is finely adjusted and sharp contact can cause it to move and lead to poor operation. Ensure the magnet remains free from dust and iron particles.
 - Do not adjust the screws attaching the magnet to the turntable. The rated performance of the unit cannot be guaranteed if the magnet is moved.

2 Attach the head shell ③.

- Fit the head shell into the tone arm, keep it horizontal and tighten the locking nut.

3 Attach the balance weight ④ to the rear of the tone arm.

- If the cartridge weighs between 10 and 13 grams, attach the included auxiliary weight ⑤ to the main balance weight.

When the player is to be used for scratch play ④

Use the disc slip sheet ⑥ instead of the turntable mat. This enables the record to be easily moved during play.

- Top (printed side): Lay the record on this side.
- Bottom: Slippery side.

For a different kind of slip

Put the transparent sheet ⑦ under the disc slip sheet.

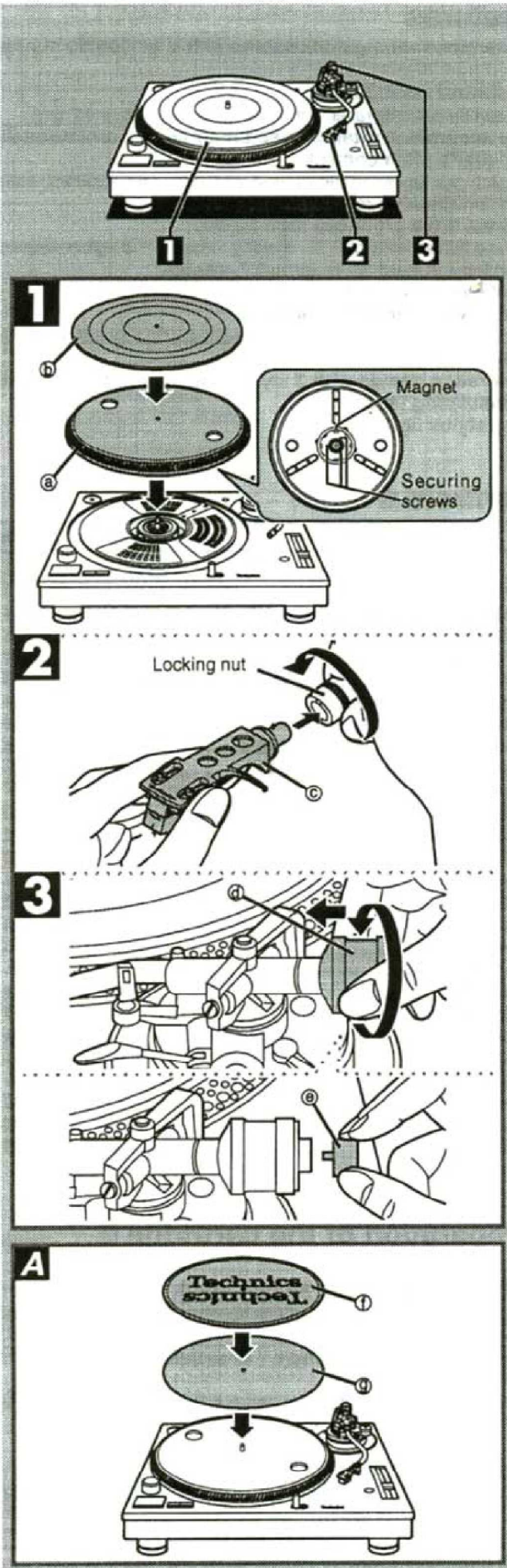

■ Connections and installation

Connecting the stereo cords and AC power cord **A**

1 Connect the stereo cords and earth lead.

If the earth lead isn't connected, a hum will be heard from the AC power source.

2 Connect the AC power cord.

- Connect this cord only after all other connections are complete.
- Confirm the wattage of AC outlets on amplifiers and receivers before using them for this unit. This unit consumes 14 W.

Connection to the SH-DJ1200 Audio Mixer **B**

- Disconnect all units from the power source before making any connections.
- Reconnect the AC power cords after all other connections are complete.

Installation

- Install the unit on a horizontal surface protected from vibrations.
- Keep this unit as far as possible from speakers.

Note

- Ensure the unit is not exposed to direct sunlight, dust, humidity, and heat from a heating appliance.
- This unit may pick up interference from a radio if there is one nearby. Keep radios as far as possible from this unit.

Adjusting the height of the insulators **C**

Place the unit where it is to be used and adjust the height of the legs to make the unit horizontal.

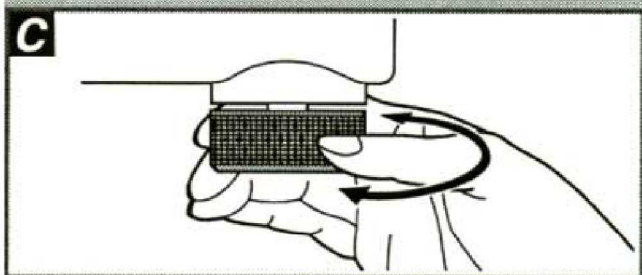
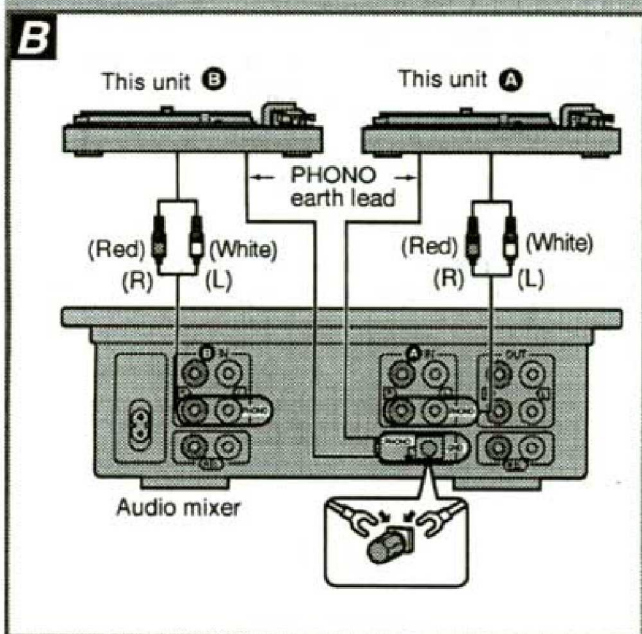
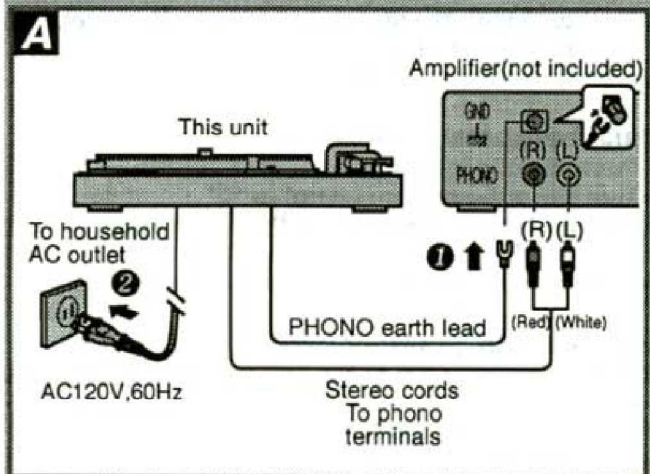

■ Preparatory adjustments

Horizontal balance and stylus pressure

1 Release the tone arm.

- 1 Take care with the stylus and remove its cover, then release the arm clamp.
- 2 Free the tone arm from the arm rest.

2 Adjust horizontal balance

- 1 Push the cue lever down.
- 2 Turn the anti-skating control to "0".
- 3 Turn the balance weight until the arm is approximately horizontal.

Take care at this time not to allow the stylus to touch the unit.

3 Turn the stylus pressure control to "0"

- 1 Return the tone arm to the arm rest and fix it with the arm clamp.
- 2 Turn the stylus pressure control to "0".
Hold the balance weight still while doing this.

4 Adjust stylus pressure

Turn the balance weight to adjust to the appropriate pressure for the cartridge you are using.

See the cartridge's instructions for recommended stylus pressure. The stylus pressure control will turn at the same time. Stop when the center line points to the required pressure.

To increase stylus pressure for scratch play **A**

Use the stylus weight (included) to increase stylus pressure by 4 grams.



1 2 3 4

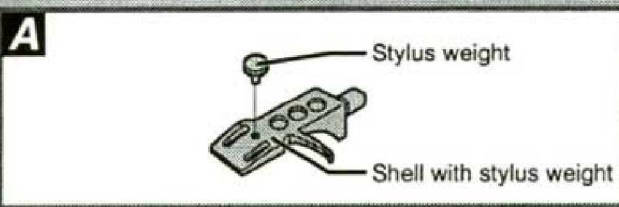
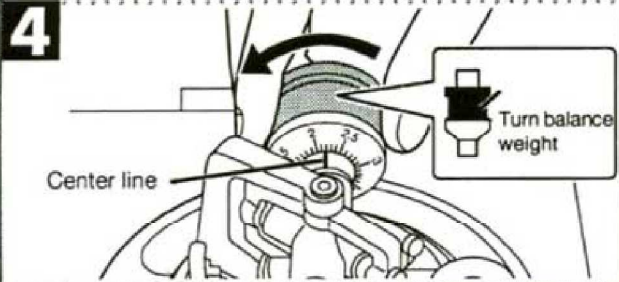
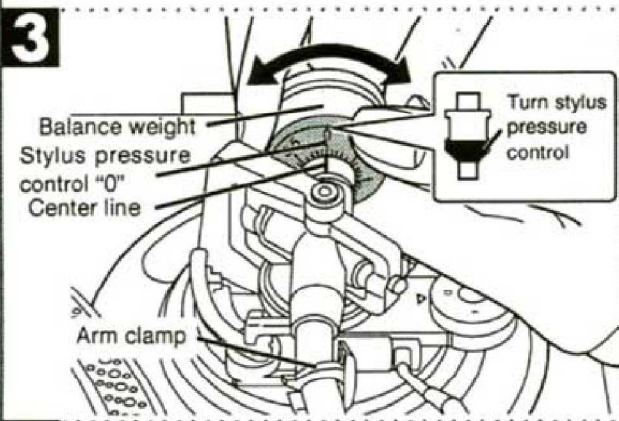
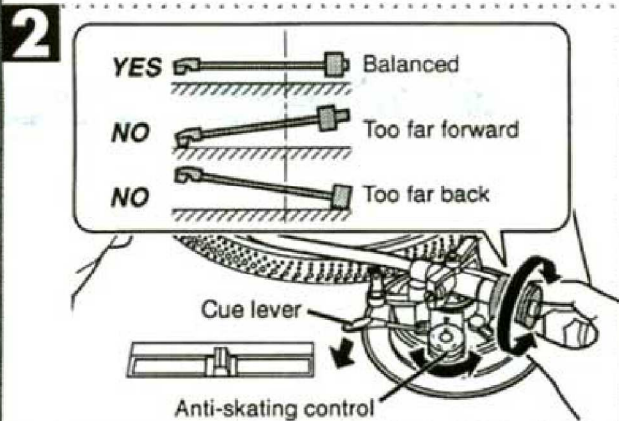
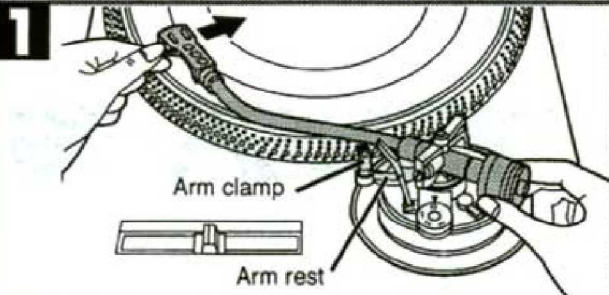

(Preparatory adjustments)

Anti-skating A

Adjust to the same value as the stylus pressure control.
If stylus pressure is over 3 grams, set this control to "3".

Tone arm height B

- 1 Release the arm lock.
- 2 Compare the height of your cartridge (H) with the following and set the arm height appropriately.

• Arm height is indicated in millimeters on the arm-height control, with marks indicating 0.5 millimeter intervals. Turn the control to the required height.

Cartridge height (H) in millimeters	Height control position
17	0
18	1
19	2
20	3
21	4
22	5
23	6

• If you do not know the height of your cartridge, rest the stylus on a record and adjust the height control until the tone arm is parallel with the record.

- 3 Lock the arm after adjusting the height.

Fit the dust cover C

Hold the dust cover with both hands and fit it over the player from directly above.

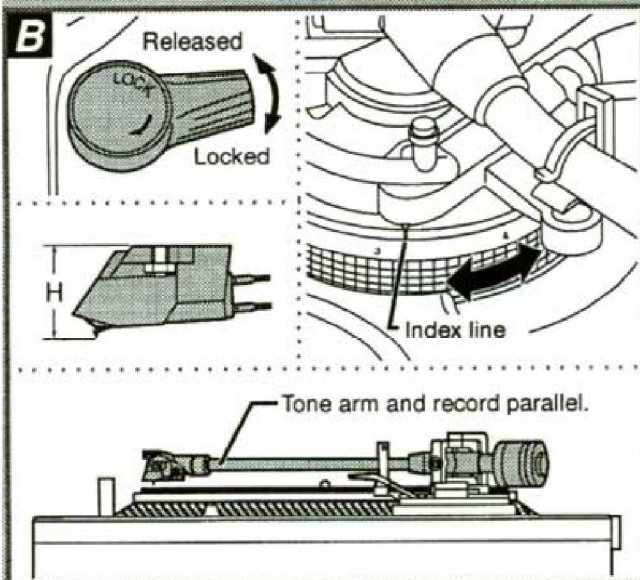
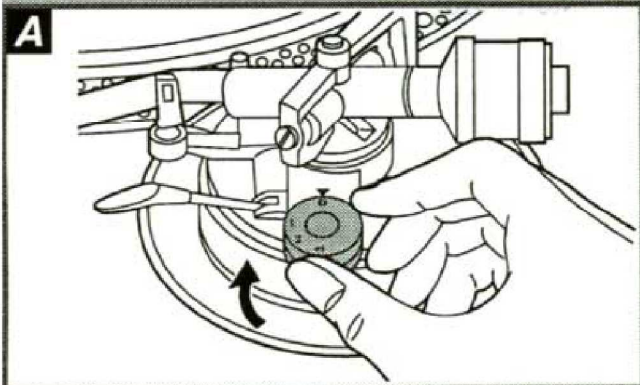

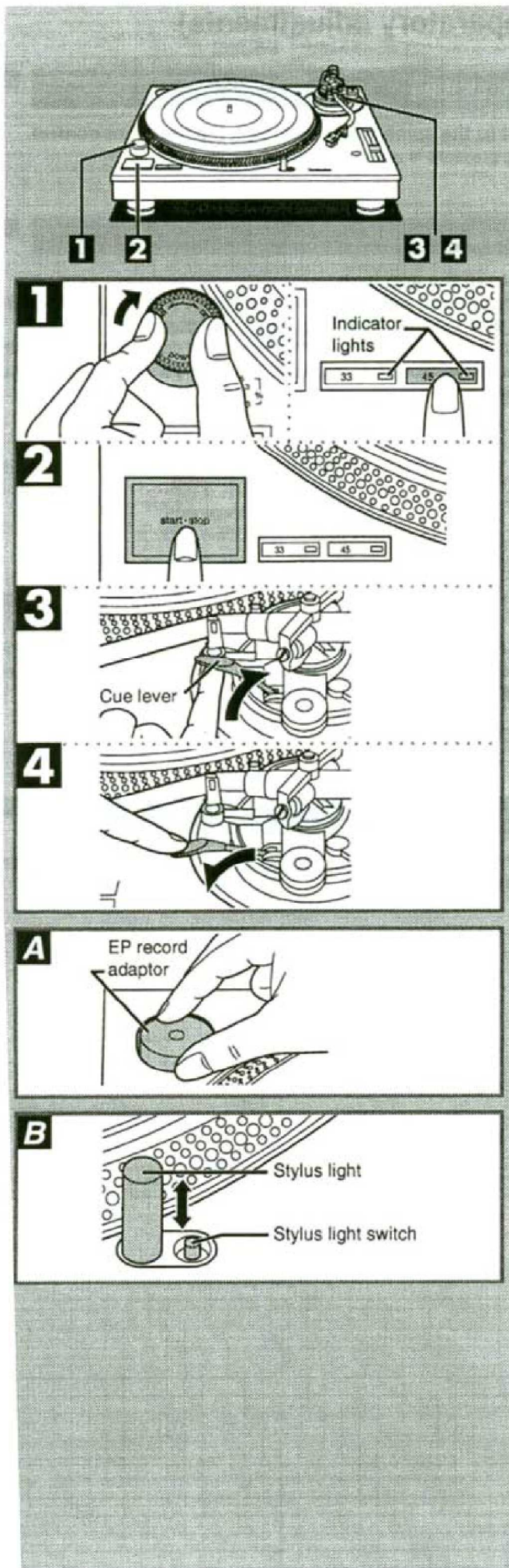

■ Playing records

Preparation

- 1 Put a record on the turntable.
- 2 Take off the stylus cover and release the arm clamp.

1 Turn [power] to turn the unit on.

- The pilot lamp comes on.
- 33 $\frac{1}{3}$ rpm is automatically selected and the indicator lights.
- Press [45] if you are playing a 45 rpm record.

2 Press [start-stop].

The turntable starts revolving.

3 Lift the cue lever and move the tone arm over the record.

4 Lower the cue lever.

The tone arm moves down and play starts.

When play finishes

- 1 Lift the cue lever and move the tone arm back to the arm rest.
- 2 Press [start-stop].
The electronic brake gently stops the turntable.
- 3 Turn [power] to turn the unit off.
- 4 Clamp the tone arm and put the stylus cover back on.

To temporarily stop play

Lift the cue lever.
The stylus lifts off the record.

When using EP records

- 1 Take the adaptor out of its holder **A** and fit it over the center spindle.
- 2 Press [45] to change the speed.

To light up the stylus **B**

- Press the stylus light switch. The light rises up and illuminates the stylus.
- When the light is not required, press it down. The light also goes out.

Note

Press the switch firmly. If the switch is lightly pressed, the light may come on but not rise up.

Adjustments while using the unit

Pitch control A

Fine adjustment to the number of revolutions per minute.

Slide [pitch adj.] while the turntable is revolving.
Move the indicator to the required position.

- The numbers represent approximate percentages.
- Pitch can be adjusted between -8% to +8%.

To reset pitch to the preset value

Press [reset].

The green lamp lights and the pitch immediately returns to the set value (33 1/3 or 45 rpm), regardless of any adjustments made with [pitch adj.]. Press [reset] again and pitch returns to the adjusted value.

To measure pitch B

The four rows of metal circles around the edge of the turntable can assist you in measuring pitch.

They are lit by the strobo light as they pass and each row appears to stand still at a different pitch.

Avoid using fluorescent light while measuring pitch. The timing will be put out and accuracy will be affected.

Armlift height C

Preparation

- 1 Put a record on the turntable.
- 2 Take off the stylus cover and release the arm clamp.

Use a screwdriver to turn the armlift screw.

Make this adjustment only if the cartridge you are using makes it necessary.

- Turning the screw clockwise lowers the armlift.
- Turning the screw anti-clockwise raises the armlift.

Note

Armlift height (the distance between the record and stylus when the cue lever is raised) is set to between 8 and 13 millimeters at time of shipment.

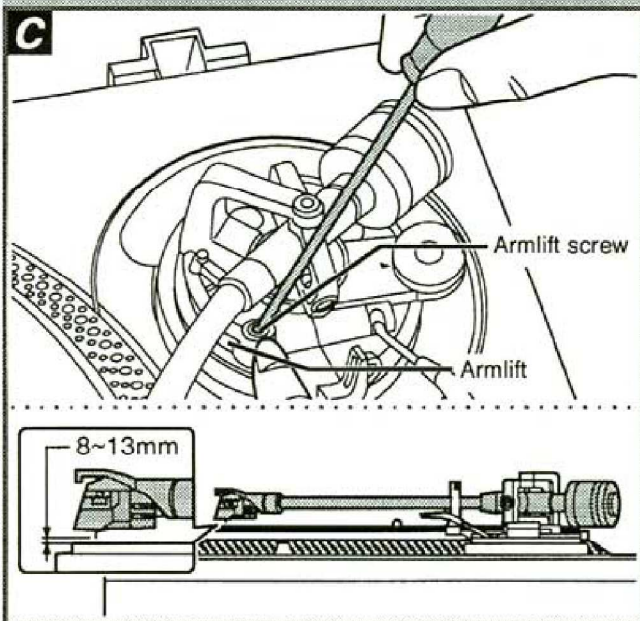
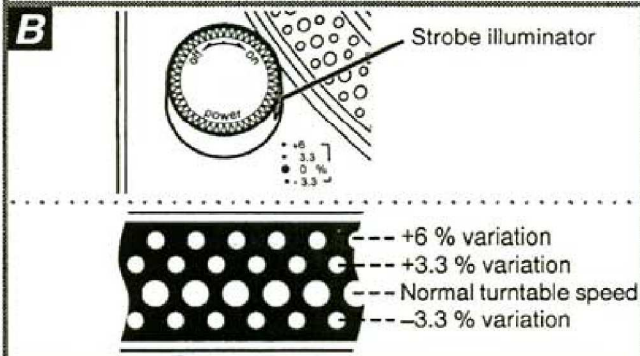
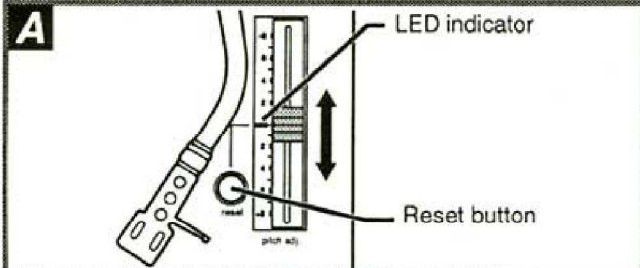
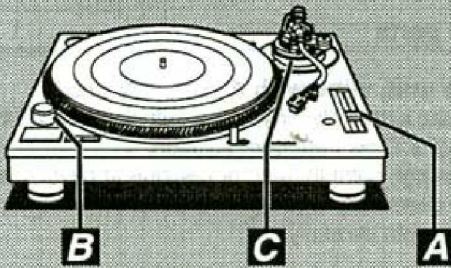

■ Maintenance

Care of the parts

To clean this unit, wipe with a soft, dry cloth.

If the surfaces are extremely dirty, use a soft cloth dipped in a soap-and-water solution or a weak detergent solution.

- Never use alcohol, paint thinner, or benzine to clean this unit.
- Before using chemically impregnated cloth, read the instructions that came with the cloth carefully.

Note

Do not wipe the dust cover while playing a record.

This can cause static electricity. This static can cause the tone arm to be attracted towards the cover.

Thoroughly clean dust off the stylus and record.

- Use a soft brush to clean the stylus. Brush from the base to the tip. **A**
- Use a good quality record cleaner to keep your records clean.

Wipe the head shell terminals occasionally **B**

Use a soft cloth. Turn the amplifier off before fitting or removing the head shell.

- Damage to your speakers can occur if the head shell is moved while the volume is turned up.
- Leave the stylus cover on while handling the head shell to prevent damaging the stylus.

Oiling the center spindle. **C**

Apply 2 or 3 drops every 2000 hours of operation. Use SFW0010 oil (not included).

Moving the unit

Repackage the unit in the packaging it came in.

If you no longer have the packaging, do the following:

- Return the tone arm to the arm rest and tape it in place.
- Remove the balance weight and head shell from the tone arm and carefully wrap them.
- Take off the turntable and turntable mat and carefully wrap them.
- Carefully wrap the main unit in a blanket or paper.

■ Product service

Do not attempt to remove the cover(s) or repair the unit yourself. Refer servicing to qualified personnel only.

Product information

For product service, product information or assistance with product operation, refer to the servicenter directory.

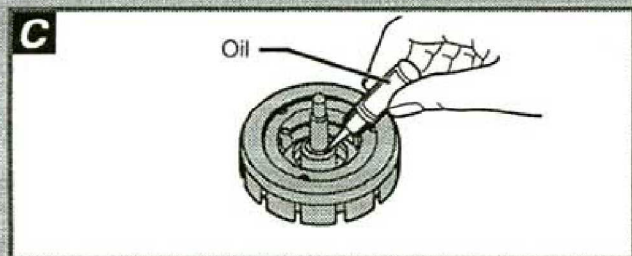
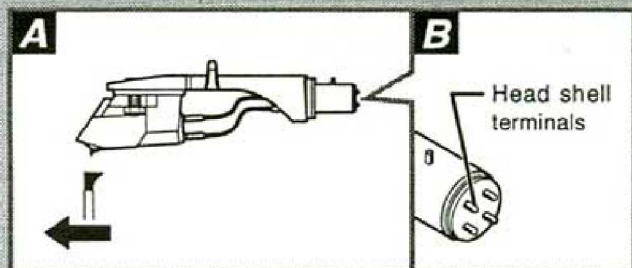

■ Troubleshooting guide

Before requesting service for this unit, check the chart below for a possible cause of the problem you are experiencing. Some simple checks or a minor adjustment on your part may eliminate the problem and restore proper operation.

If you are in doubt about some of the check points, or if the remedies indicated in the chart do not solve the problem, refer to the directory of Authorized Service Centers (enclosed with this unit) to locate a convenient service center, or consult your dealer for instructions.

For detailed instructions, contact an authorized servicenter in the U.S.A. and Panasonic Canada Inc. Customer Care Centre in Canada.

In the U.S.A. 1-800-211-7262 or web site

(<http://www.panasonic.com>)

In Canada 905-624-5505 or web site

(www.panasonic.ca)

Problem	Probable cause(s)	Suggested remedy	Reference page(s)
No power.	Is the AC power cord plugged in?	Plug the cord in firmly.	5
There is power but no sound.	Are connections to the amplifier or receiver correct?	Double check all connections.	5
Left and right sounds are reversed.	Are the stereo cord connections to the amplifier or receiver reversed?	Double check all connections.	5
Humming heard during play.	Are there other appliances or their power cords near the stereo cords?	Separate the appliances and their power cords from this unit.	—
	Is the earth lead connected?	Make sure the earth lead is correctly connected.	5

■ Operation Checks and Component Replacement Procedures

- NOTE**
1. This section describes procedures for checking the operation of the major printed circuit boards and replacing the main components.
 2. For reassembly after operation checks or replacement, reverse the respective procedures. Special reassembly procedures are described only when required.
 3. Select item from the following index when checks or replacement are required.

● Contents

■ Checking Procedures for each P.C.B.

1. Checking for the drive control P.C.B. and power supply P.C.B. Page. 12.

■ Main Component Replacement Procedures

1. Replacement for the drive coil ass'y and FG coil ass'y. 13.
2. Replacement for the tonearm unit. 13-16.
3. Replacement for the lamp and stylus illuminator switch. 16.
4. Replacement for the parts mounted on speed selector P.C.B. and power switch. 16.

■ Checking Procedures for each P.C.B.

1. Checking for the drive control P.C.B. and Power supply P.C.B.

Step 1

Remove the turntable mat and turntable ass'y.

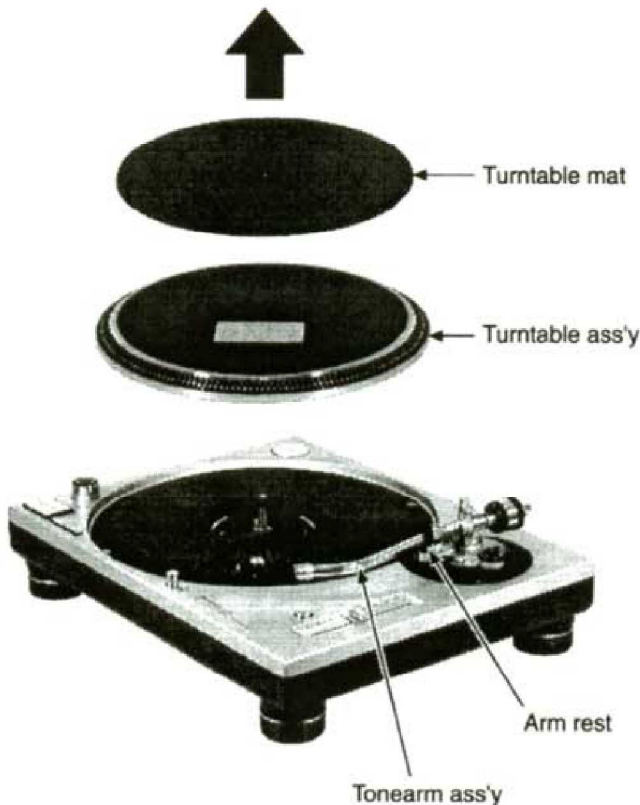

NOTE

1. The tonearm ass'y should be supported by arm rest.
2. Take care not to stick the dust or iron powder to the magnet attached to back inner side of turn table.

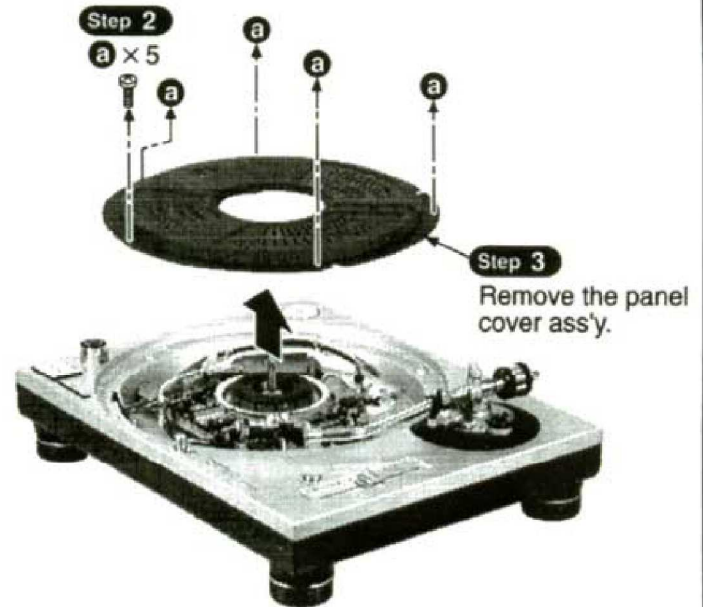

• Check the drive control P.C.B. and power supply P.C.B. as shown below.

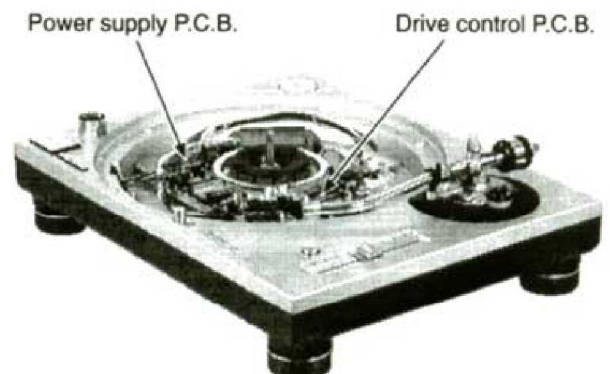

■ Main Component Replacement Procedures

1. Replacement for the drive coil ass'y and FG coil ass'y

- Follow the **Step 1** - **Step 3** of the item 1 in checking procedure for each P.C.B. on page 12.

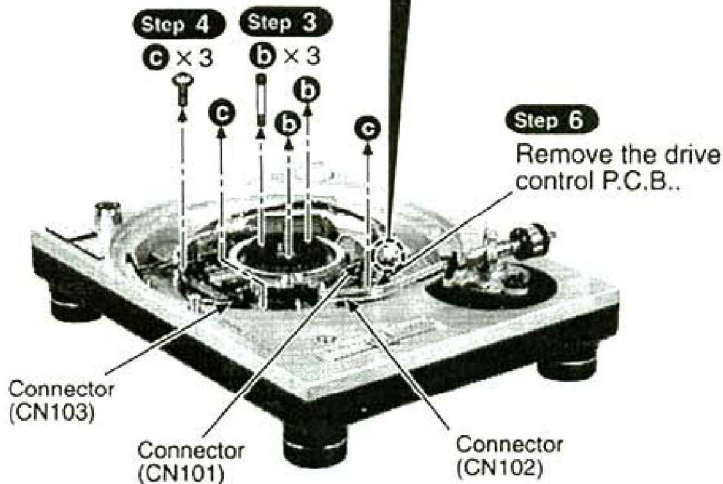
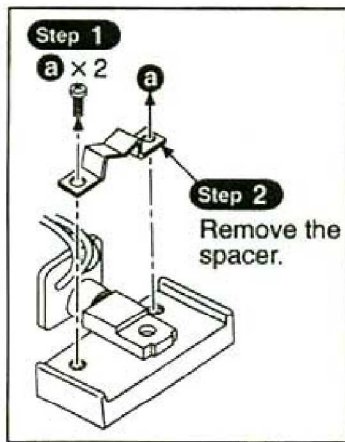

- Step 5**
Remove the 3 connectors.

Removal of the connector

- Release the claws, and then pull out the connector.

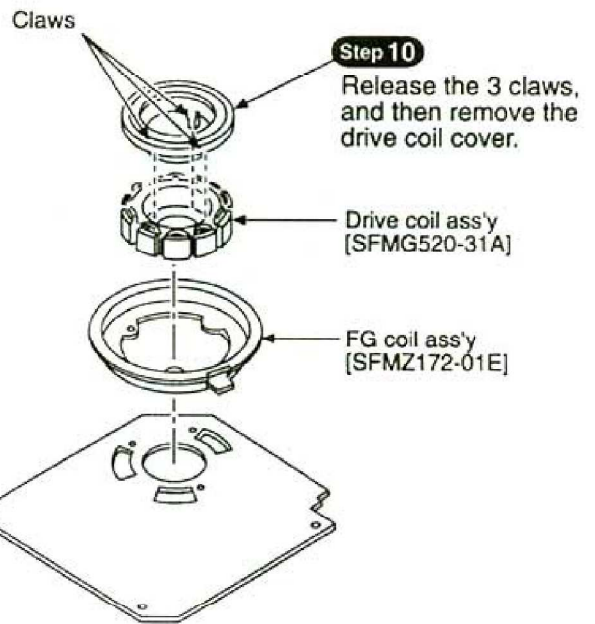
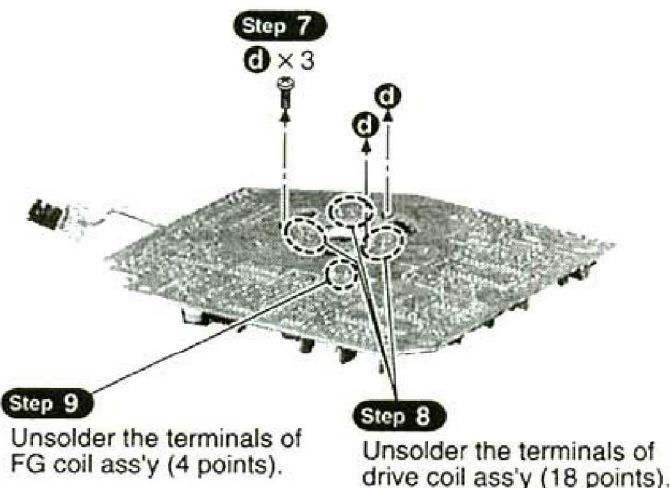
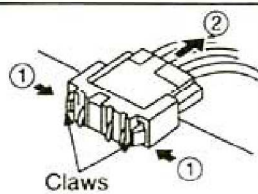

2. Replacement for the tonearm unit

- Follow the **Step 1** of the item 1 in checking procedure for each P.C.B. on page 12.

- Step 1**
Upset the unit, and then put the dust cover.

- Step 2**
Turn the insulators in the direction of arrow, and then remove them (4 points).

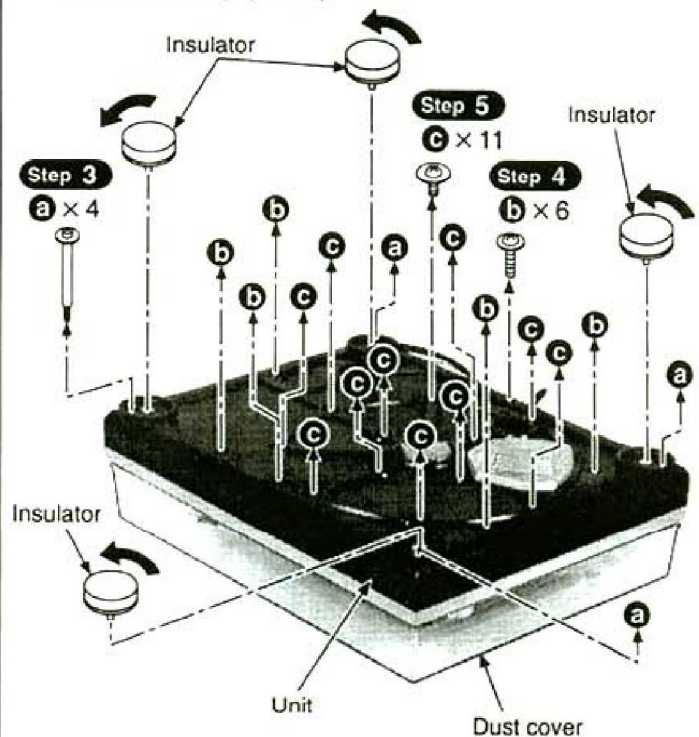

NOTE

- Use the soft cloth under the unit to prevent damage the dust cover when servicing.

Step 6

Remove the bottom cover (A) ass'y.

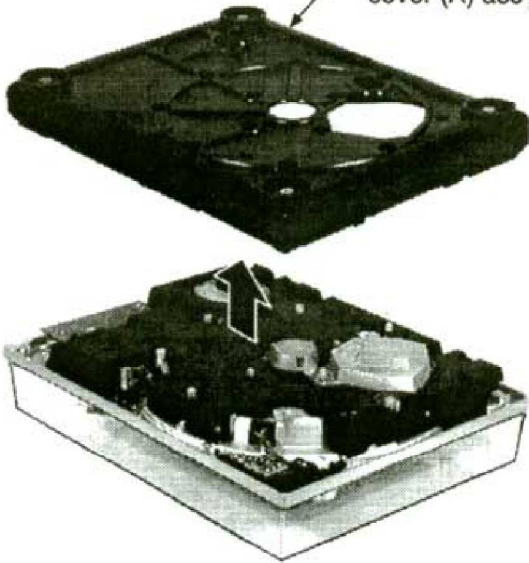

Step 8

Remove the bottom cover (B) ass'y.

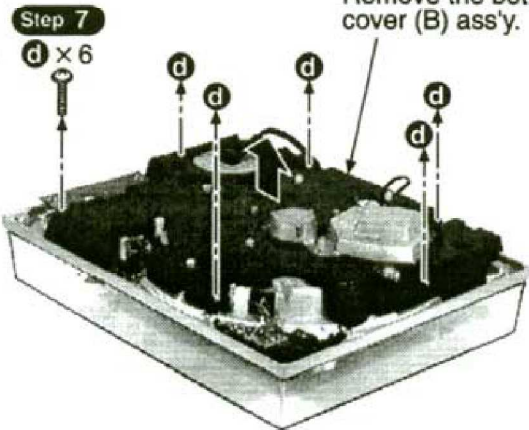

Step 9

e x 3

Step 10

f

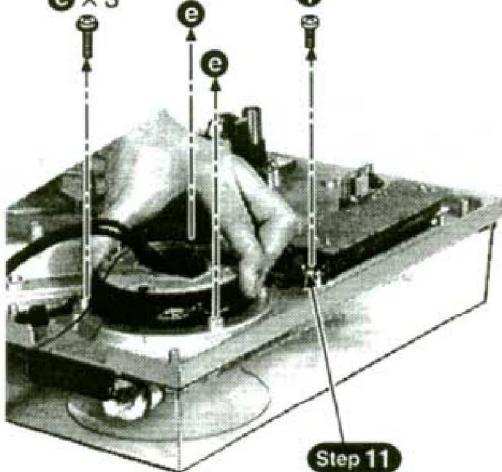

Step 11

Remove the lug terminal.

NOTE

Hold the tonearm with hand when removing the 3 screws (e).

Tonearm ass'y

Cabinet ass'y

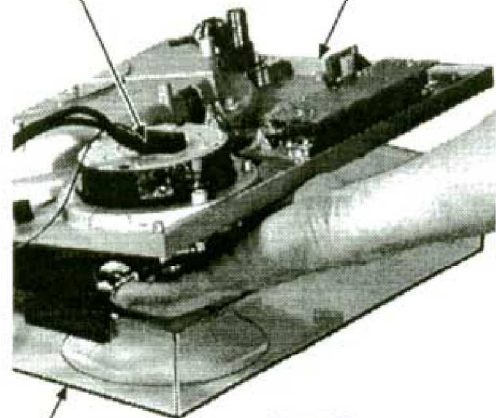

Dust cover

Step 12

Separate the dust cover and the cabinet ass'y, and then remove the tonearm ass'y.

Step 14

h x 2

Step 13

g x 2

Step 16

Remove the arm base cover plate.

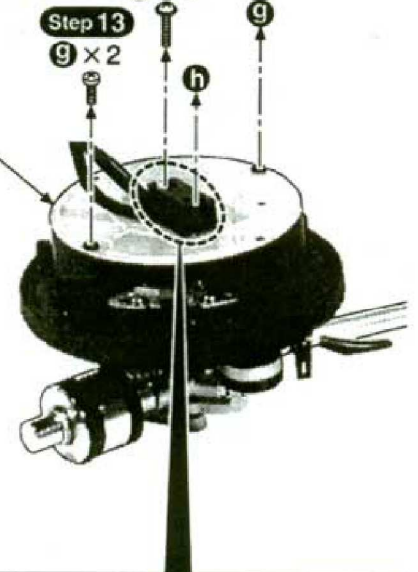

Claws

Phono cord clumper

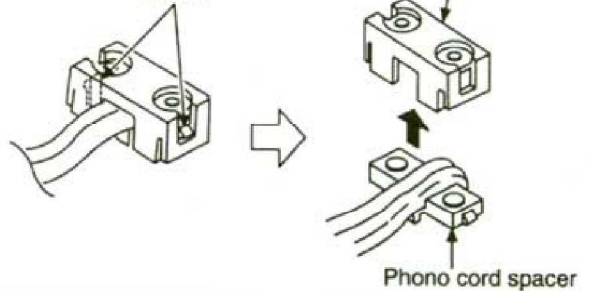

Phono cord spacer

Step 15

Release the 2 claws, and then remove the phono cord clumper and phono cord spacer.

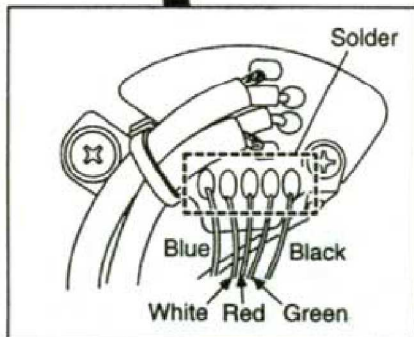
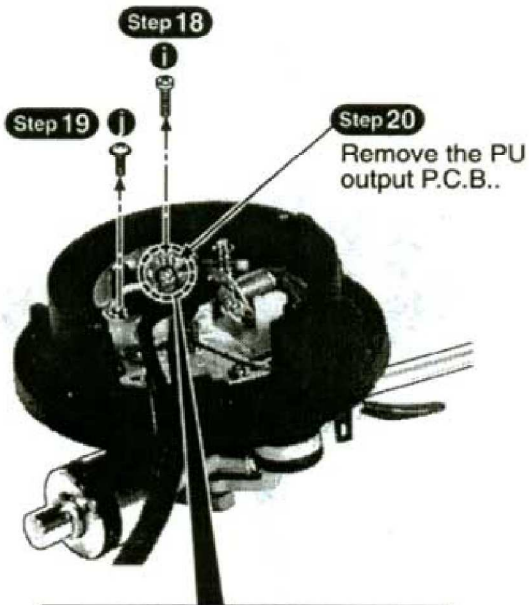

Step 17
Unsolder the terminals (5 points).

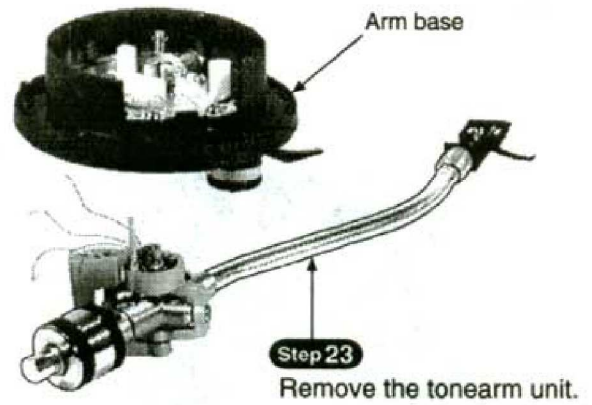
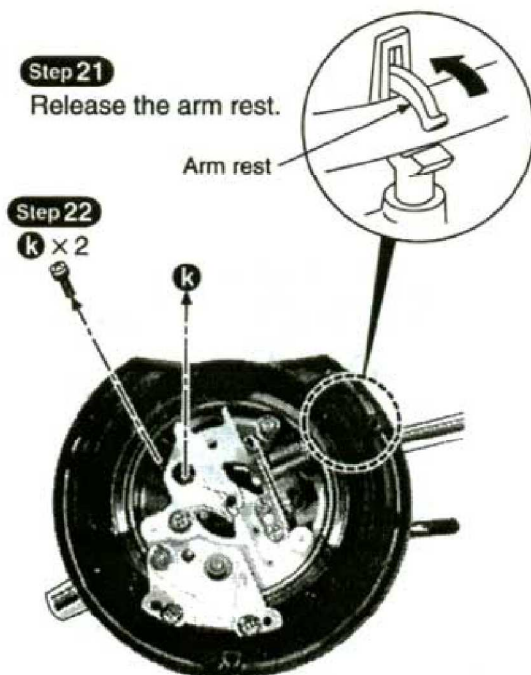

Reassembly procedures for tonearm ass'y

Step 1
Rotate the arm base knob in the direction of arrow, and then align the pointer with the scale "0".

Step 2
Rotate the canceler knob in the direction of arrow, and then align the pointer with the scale "0".

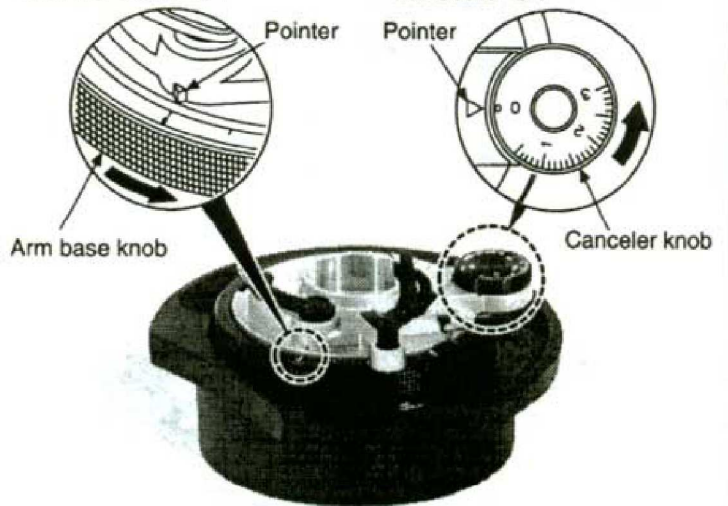

Step 3
Pass the 5 lead wires through the hole of arm basement.

※ When passing the lead wire through the hole, for easy operation, wrap the ends of 5 lead wires with tape.

Step 4
Install the tonearm unit.

Step 5
Support the tonearm unit with arm rest.

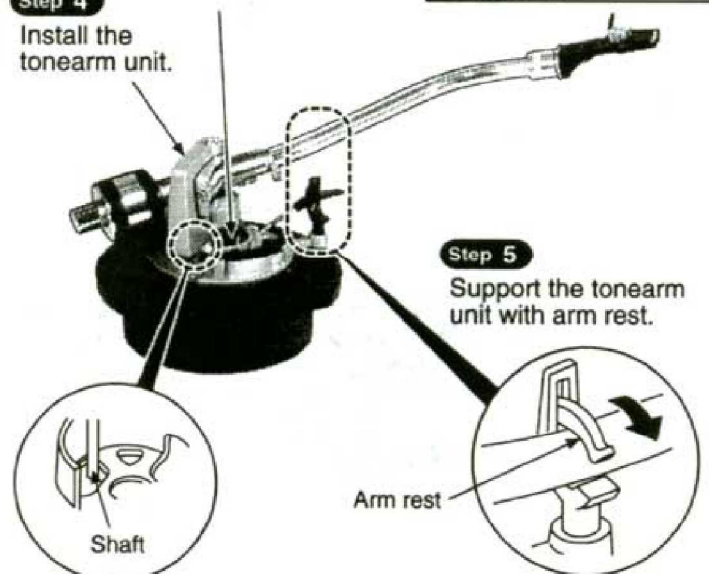

Step 6

Tighten the tonearm unit screws.

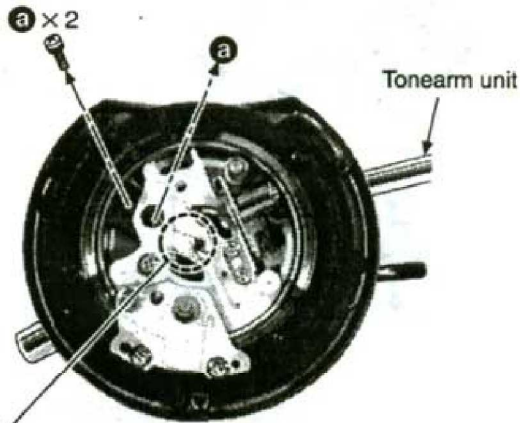

Step 7

Remove the tape of lead wire.

3. Replacement for the lamp and stylus illuminator switch

• Follow the **Step 1** ~ **Step 6** of the item 2 in main component replacement procedures on pages 13 and 14.

Step 1

a × 2

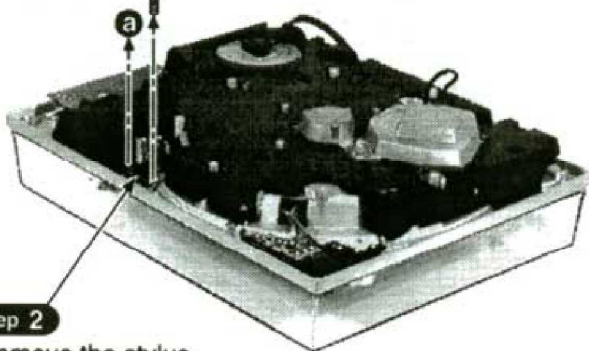

Step 2

Remove the stylus illuminator unit.



Step 4

Remove the stylus illuminator cover.

Step 5

Remove the lamp. [SFDN122-01E]

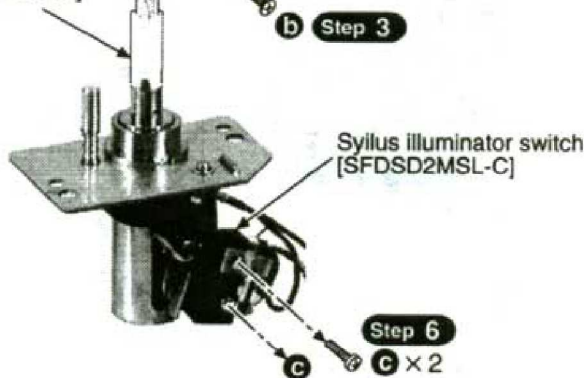

Step 6

c × 2

4. Replacement for the parts mounted on speed selector P.C.B. and power switch

• Follow the **Step 1** ~ **Step 7** of the item 2 in main component replacement procedures on pages 13 and 14.

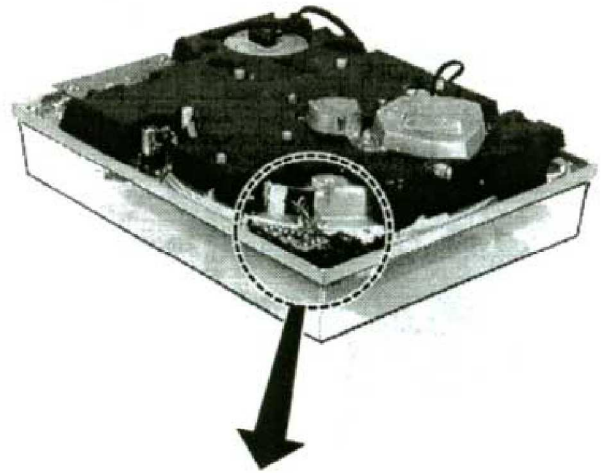

Step 1

a

b

Step 2

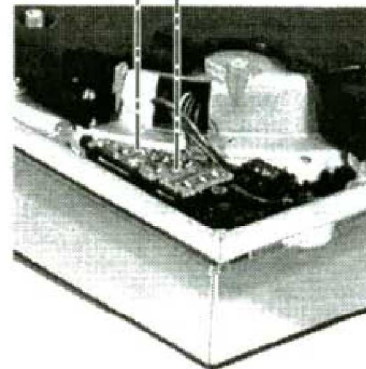

Step 4

c

Speed selector P.C.B.

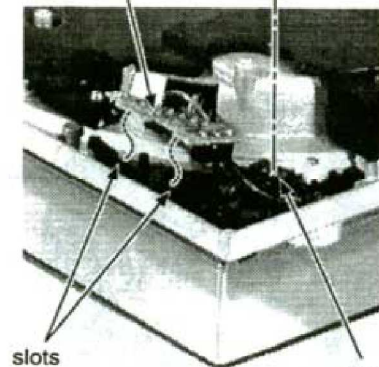

Step 3

Remove the speed selector P.C.B..

■ Schematic Diagram

- Notes:**
- S201 : SPEED SELECTOR (33 rpm) switch.
 - S202 : SPEED SELECTOR (45 rpm) switch.
 - S203 : START/STOP switch.
 - S301 : PITCH CONTROL RESET switch in "OFF" position. (Interlocked with VR303)
 - S302 : PITCH RESET switch in "OFF" position.
 - S401 : STYLUS ILLUMINATOR switch in "ON" position.
 - S601 : POWER switch in "ON" position.
 - VR201 : BRAKE ADJUSTMENT VR.
 - VR301 : PITCH CONTROL $\pm 0\%$ ADJUSTMENT VR.
 - VR302 : PITCH CONTROL GAIN ADJUSTMENT VR.
 - VR303 : PITCH CONTROL ADJUSTMENT VR. (Interlocked with S301)

● The voltage value and waveforms are the reference voltage of this measured by DC electronic voltmeter (high impedance) and oscilloscope on the basis of chassis. Accordingly, there may arise some errors in the voltage values and waveforms depending upon the internal impedance of the tester or the measuring unit.

● Important safety notice:

Components identified by  mark have special characteristics important for safety. When replacing any of these components, use only manufacturer's specified parts.

NO MARK: Voltage when at a stop

() : Voltage during rotation

●  : +B Line

【For U.S.A. model only】

CAUTION : FOR CONTINUED PROTECTION AGAINST FIRE HAZARD, REPLACE ONLY WITH SAME TYPE F1 1.2A 125V FUSE.



RISK OF FIRE-REPLACE FUSE AS MARKED.

【For CANADA model only】

FUSE CAUTION



These symbols located near the fuse indicates that the fuse used is a fast operating type. For continued protection against fire hazard, replace with the same type fuse. For fuse rating, refer to the marking adjacent to the symbol.



Ce symbole indique que le fusible utilisé est à rapide. Pour une protection permanente, n'utiliser que des fusibles de même type. Ce dernier est indiqué là où le présent symbole est apposé.

● Type Illustration of IC's, Transistors and Diodes

<p>TC4011BP</p>	<p>AN6682</p>	<p>AN6680</p>	<p>AN6675</p>	<p>2SC2458GR</p>	<p>2SD1265-0PQ</p>
<p>2SC1846-QRS</p>	<p>2SD637-QRS</p>	<p>MA4051MTA</p>	<p>MA165TA</p>	<p>GL8EG21</p>	<p>SVDEBR5505S</p>
<p>D2SBA20</p>	<p>SVDPR3902S-9</p>				

F POWER SUPPLY CIRCUIT

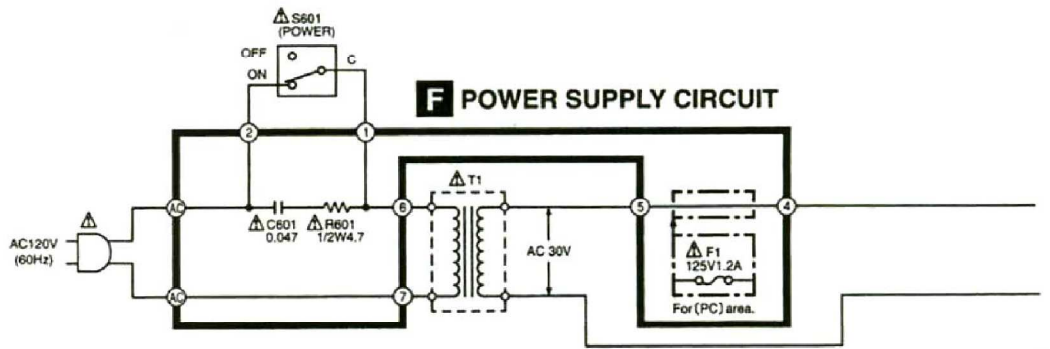

A DRIVE CONTROL CIRCUIT

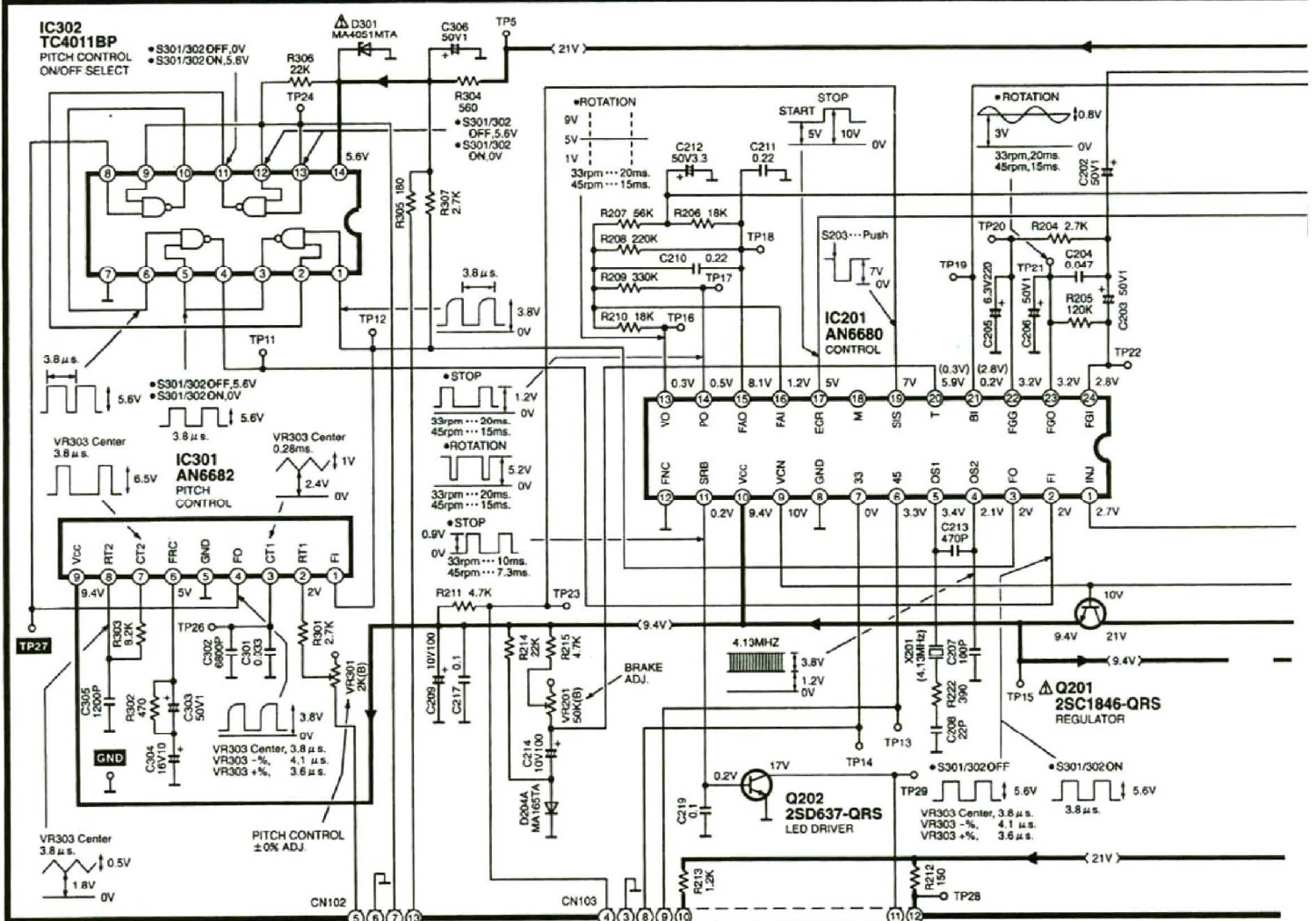

B PITCH RESET SWITCH CIRCUIT

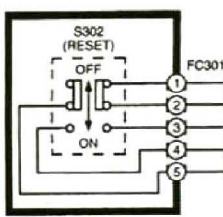

C PITCH CONTROL CIRCUIT

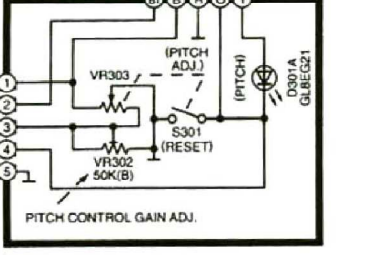

D SPEED SELECTOR CIRCUIT

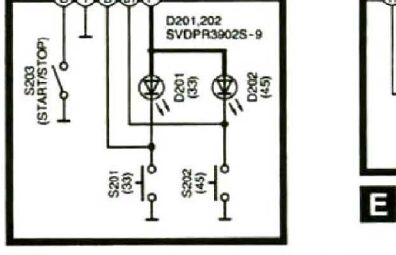

E STROBE ILLUMINATOR CIRCUIT

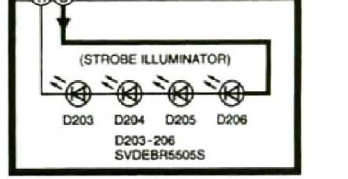

G REGULATOR CIRCUIT

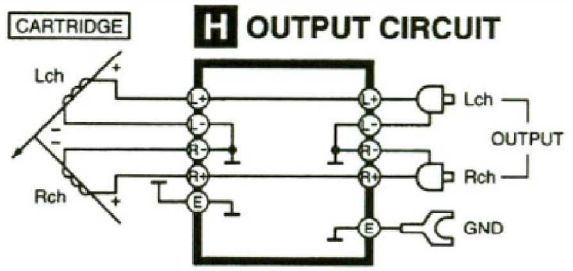
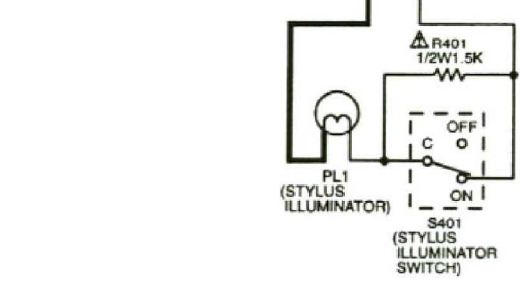
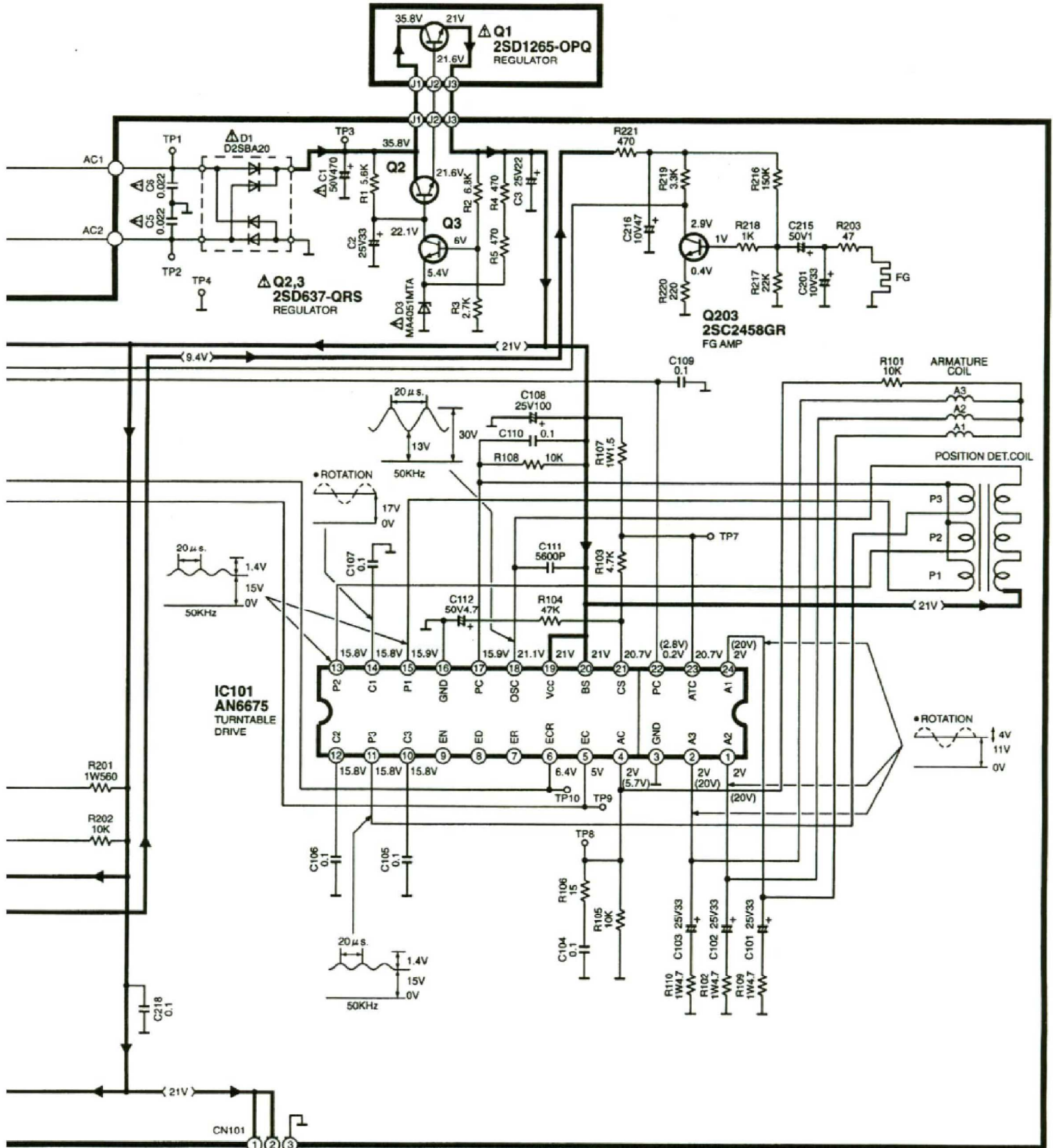

Printed Circuit Boards

A DRIVE CONTROL P.C.B.

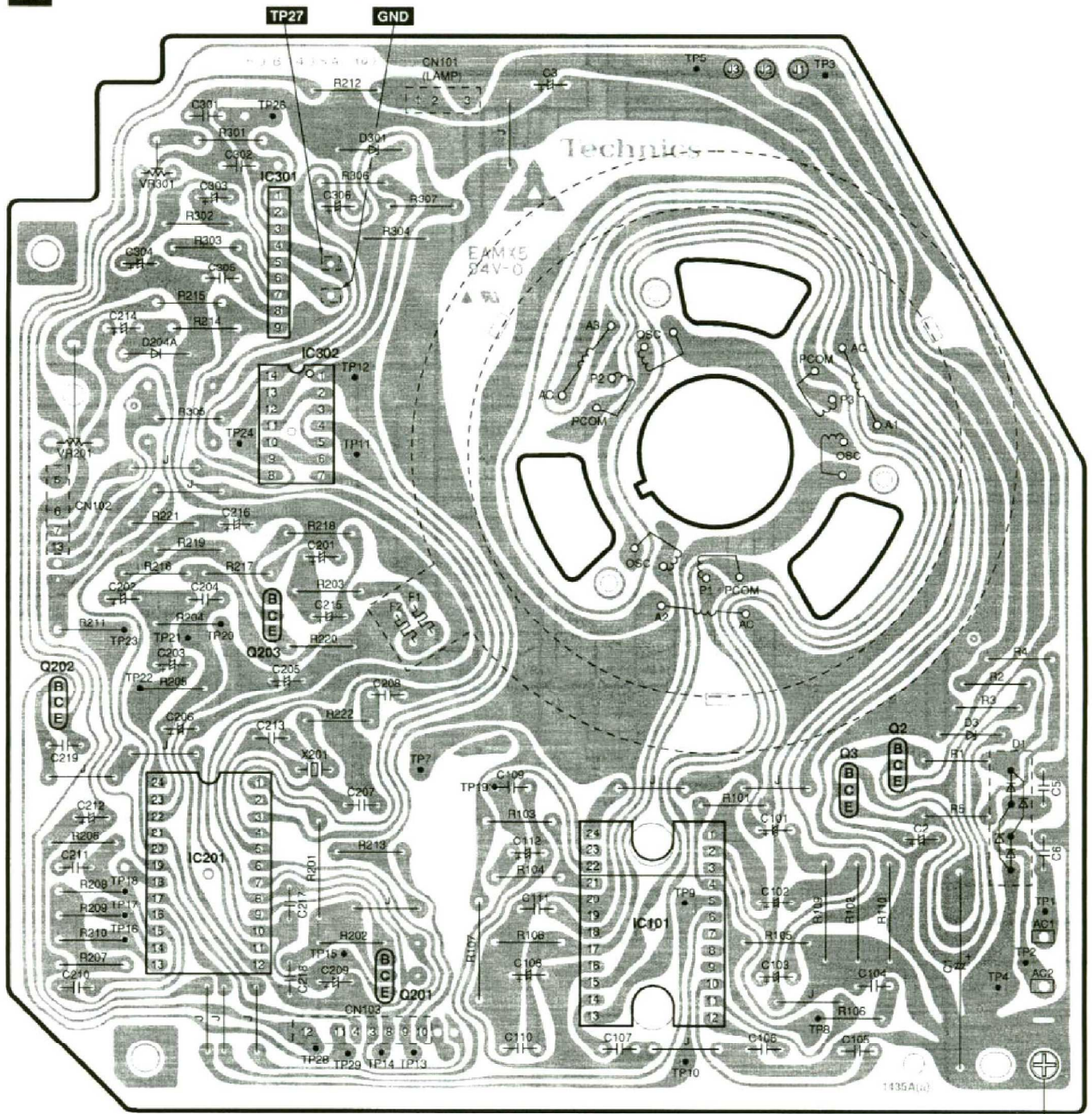

ELECTRICAL PARTS LOCATION

Ref. No.	Lo. No.	Ref. No.	Lo. No.	Ref. No.	Lo. No.	Ref. No.	Lo. No.	Ref. No.	Lo. No.	Ref. No.	Lo. No.	Ref. No.	Lo. No.	Ref. No.	Lo. No.
A DRIVE P.C.B.															
IC101	6D	CN101	1C	TP11	3C	AC1	6F	R201	5B	R219	4B	C103	6E	C209	6B
IC201	5B	CN102	3A	TP12	3C	AC2	6F	R202	6C	R220	4B	C104	6E	C210	6A
IC301	2B	CN103	6C	TP13	6C	GND	2B	R203	4B	R221	4B	C105	6E	C211	5A
IC302	3B	P1	4D	TP14	6C	R1	5F	R204	4B	R222	5C	C106	6E	C212	5A
Q2	5E	P2	3D	TP15	6C	R2	4F	R205	4B	R301	2B	C107	6D	C213	5B
Q3	5E	P3	3E	TP16	6A	R3	4F	R206	5A	R302	2B	C108	6C	C214	3A
Q201	6C	J1	1E	TP17	6A	R4	4F	R207	6A	R303	2B	C109	5C	C215	4B
Q202	4A	J2	1E	TP18	5A	R5	5F	R208	5A	R304	2C	C110	6C	C216	4B
Q203	4B	J3	1E	TP19	5C	R101	5E	R209	6A	R305	3B	C111	6D	C217	5B
D1	5F	TP1	6F	TP20	4B	R102	6E	R210	6A	R306	2C	C112	5C	C218	6B
D3	5F	TP2	6F	TP21	4B	R103	5C	R211	4A	R307	2C	C201	4B	C219	5A
D204A	3B	TP3	1E	TP22	4A	R104	5C	R212	1C	C1	6F	C202	4A	C301	1B
D301	2C	TP4	6F	TP23	4A	R105	6E	R213	5C	C2	5E	C203	4B	C302	2B
VR201	3A	TP5	1D	TP24	3B	R106	6E	R214	3B	C3	1D	C204	4B	C303	2B
VR301	2B	TP7	5C	TP26	1B	R107	6C	R215	2B	C5	5F	C205	4B	C304	2A
X201	5B	TP8	6E	TP27	2B	R108	6C	R216	4B	C6	5F	C206	5B	C305	2B
F1	4C	TP9	5D	TP28	6B	R109	6E	R217	4B	C101	5E	C207	5C	C306	2B
F2	4C	TP10	6D	TP29	6C	R110	6E	R218	4B	C102	5E	C208	4C		

A

B

C

D

E

F

1

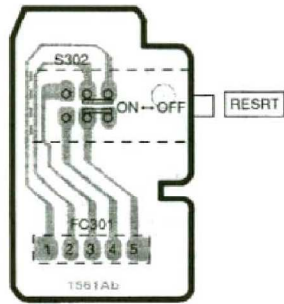
B PITCH RESET SWITCH P.C.B.

(REP2221A-2)

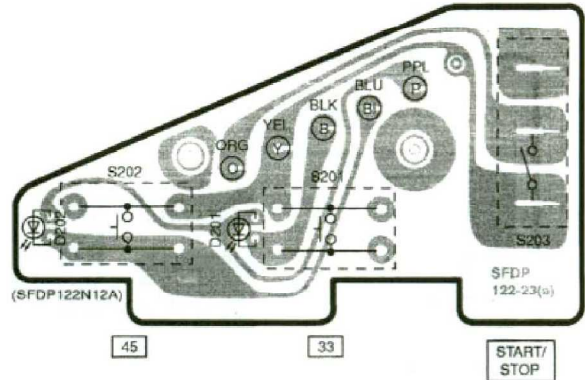
D SPEED SELECTOR P.C.B.

45

33

START/
STOP

2

3

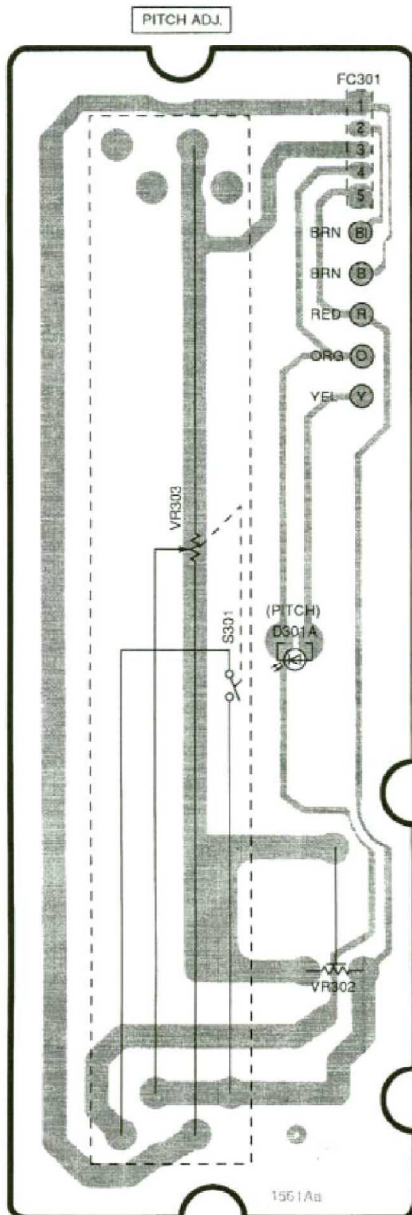
C PITCH CONTROL P.C.B.

(REP2221A-2)

4

5

6

7

8

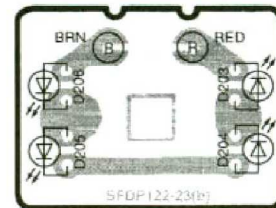
E STROBE ILLUMINATOR P.C.B.

(SFDP122N12A)

ELECTRICAL PARTS LOCATION

Ref. No.	Lo. No.	Ref. No.	Lo. No.
B PITCH RESET SWITCH P.C.B.			
S302	2B	FC301	2B
C PITCH CONTROL P.C.B.			
D301A	6B	S301	6B
VR302	7C	FC301	4C
VR303	5B		
D SPEED SELECTOR P.C.B.			
D201	2E	S202	2D
D202	2D	S203	2F
S201	2E		
E STROBE ILLUMINATOR P.C.B.			
D203	4E	D205	5D
D204	5E	D206	4D

A B C D E F

1
2
3
4
5
6
7
8

F POWER SUPPLY P.C.B.

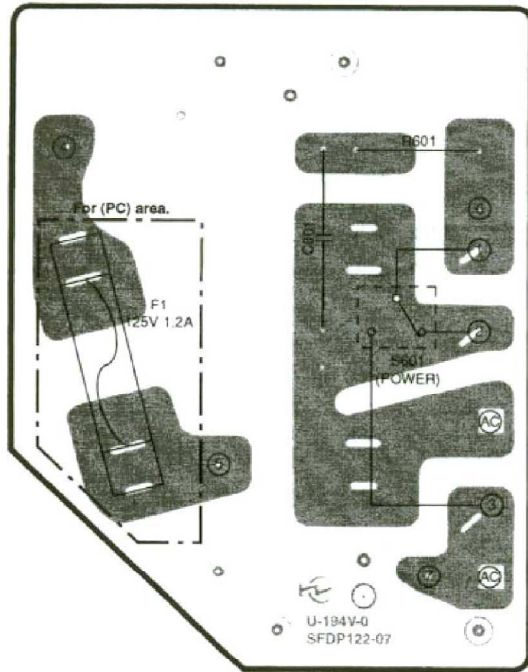

(SFDP122M06E [P])
(SFDP122C06E [PC])

G REGULATOR P.C.B.

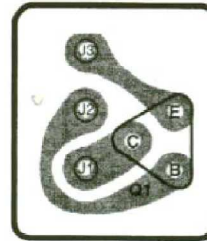

(REP2094A-1)

ELECTRICAL PARTS LOCATION

Ref. No.	Lo. No.	Ref. No.	Lo. No.
F POWER SUPPLY P.C.B.			
F1	3B	R601	2C
S601	3C	C601	2B
G REGULATOR P.C.B.			
Q1	2E	J2	2E
J1	2E	J3	2E
H OUTPUT P.C.B.			
L-	6D	R+	6D
L+	6D	E	6D
R-	6D		6D

H OUTPUT P.C.B.

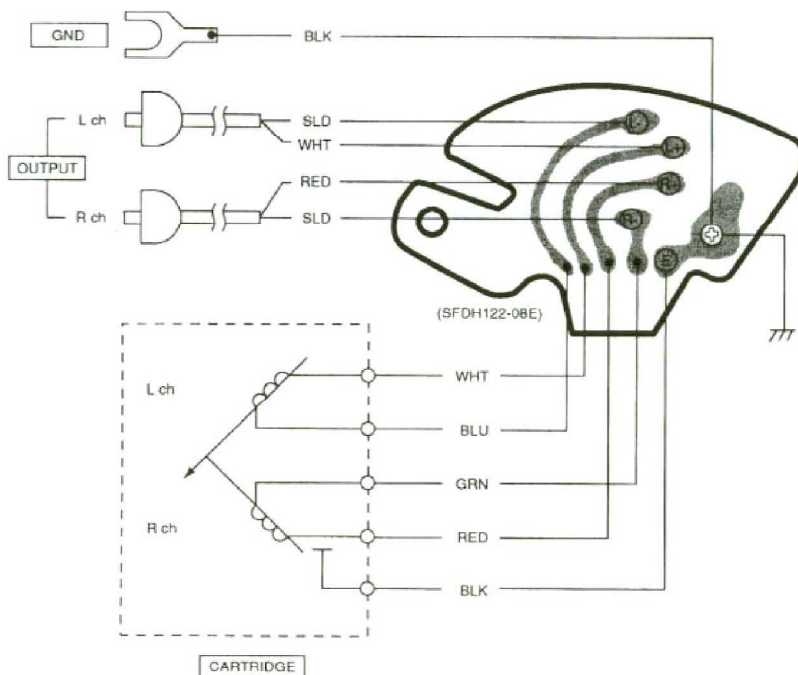

■ Measurements and Adjustments

Notes: • Make the following adjustments after replacing parts such as IC's, Transistors, Diodes, etc.

- Condition of the set.
 1. Power switch.....ON
 2. Pitch control.....Center position
 3. Speed selector switch.....33 r.p.m.
- Instruments to be used
 1. Tester
 2. Frequency counter

	Adjustment	Connection	Parts adjusted	Procedure
1	Pitch control $\pm 0\%$ adjustment	Frequency counter (+) ... TP27 (-) ... Earth point	VR301 (Fig. 1)	<ol style="list-style-type: none"> 1. Connect the frequency counter and turn the power supply ON. 2. Set the pitch control knob to "0". (Indicator lights up.) 3. Adjust VR301 so that the frequency is $262.08 \text{ kHz} \pm 0.05 \text{ kHz}$.
2	Pitch control gain adjustment	Tester (+) ... CN102 terminal ⑤ (-) ... CN102 terminal ⑥	VR302 (Fig. 2)	<ol style="list-style-type: none"> 1. Set the pitch control knob to "0". 2. Pull out the connector CN102 of drive P.C.B. 3. Connect the tester to terminals, ⑤ and ⑥ of connector CN102 on the pitch control P.C.B. side. 4. Adjust VR302 so that the resistance value of the tester is $2.875 \pm 0.25 \text{ k}\Omega$.
3	Brake adjustment	—————	VR201 (Fig. 1)	<ol style="list-style-type: none"> 1. Adjust VR201 so that the rotation at 33 r.p.m. stops within the angle of $30^\circ \sim 210^\circ$ after depressing the stop position.

● Alignment Points

Please refer to Printed Circuit Board Diagram for test point locations.

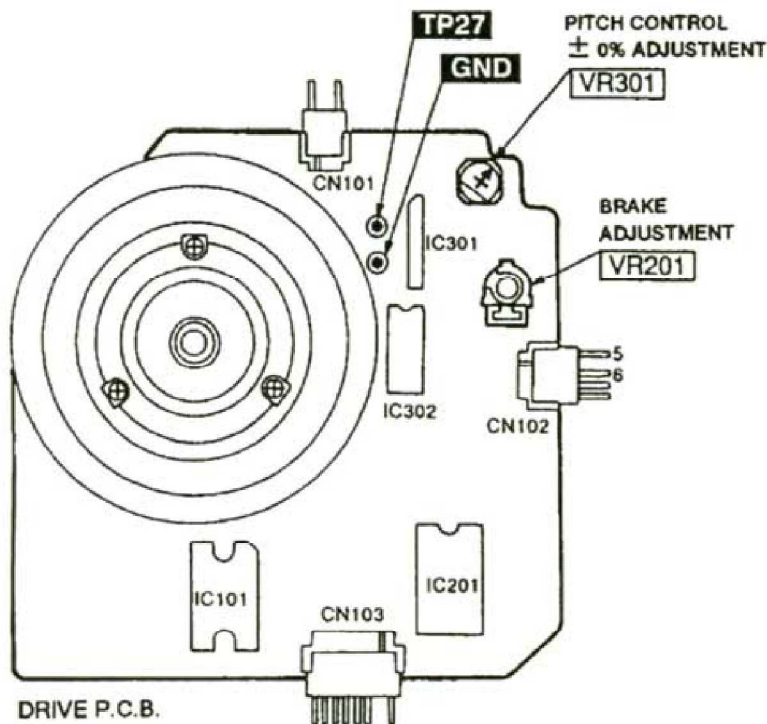

Fig. 1

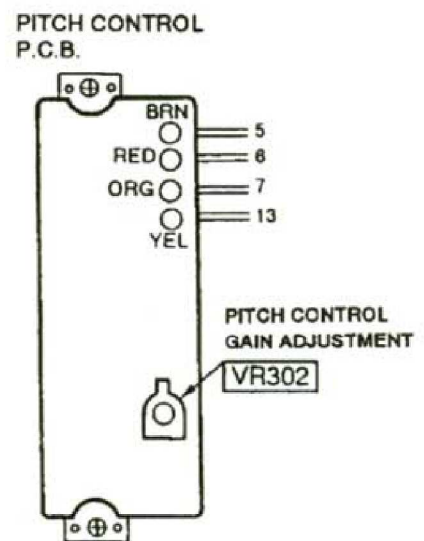
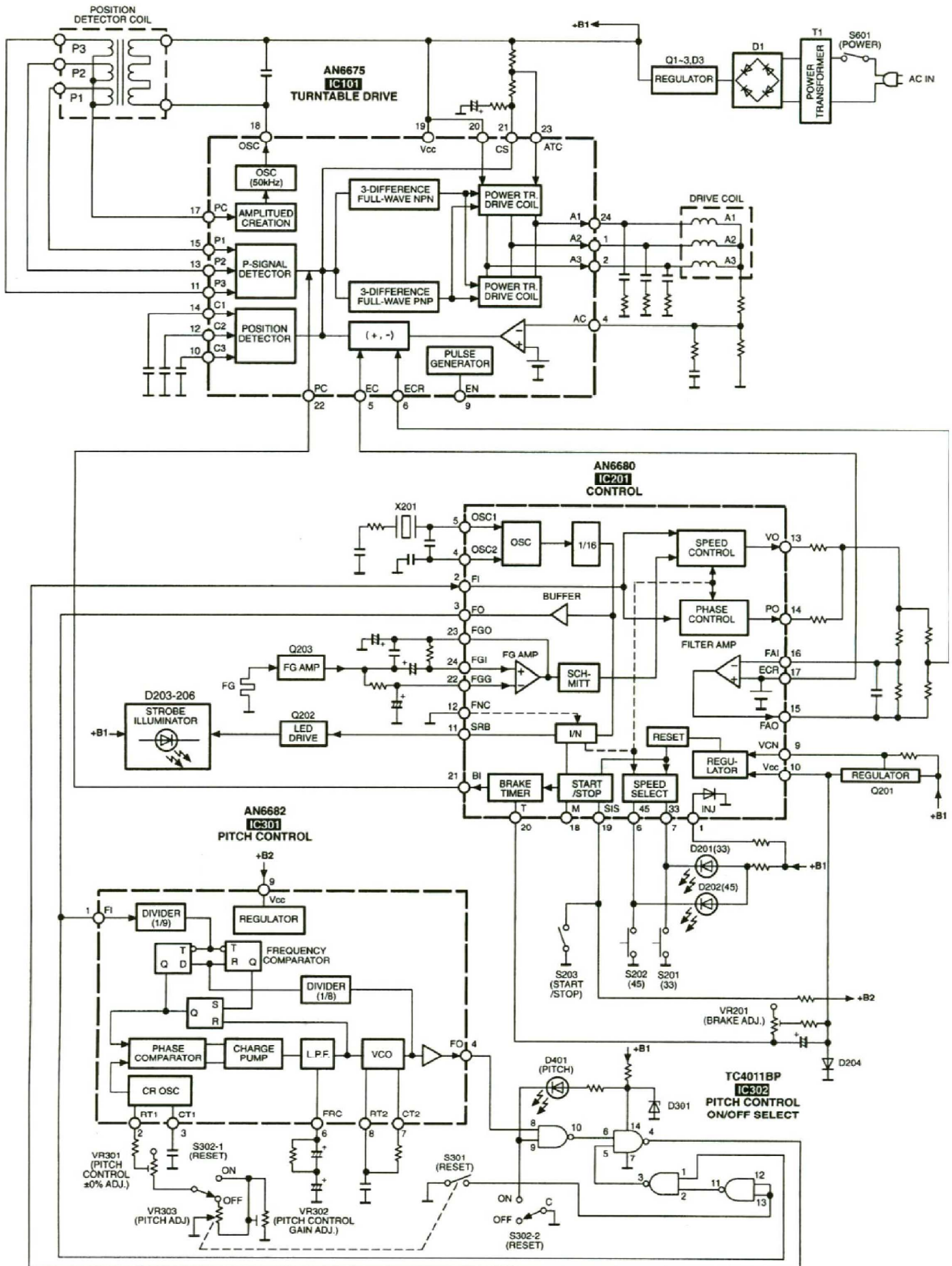
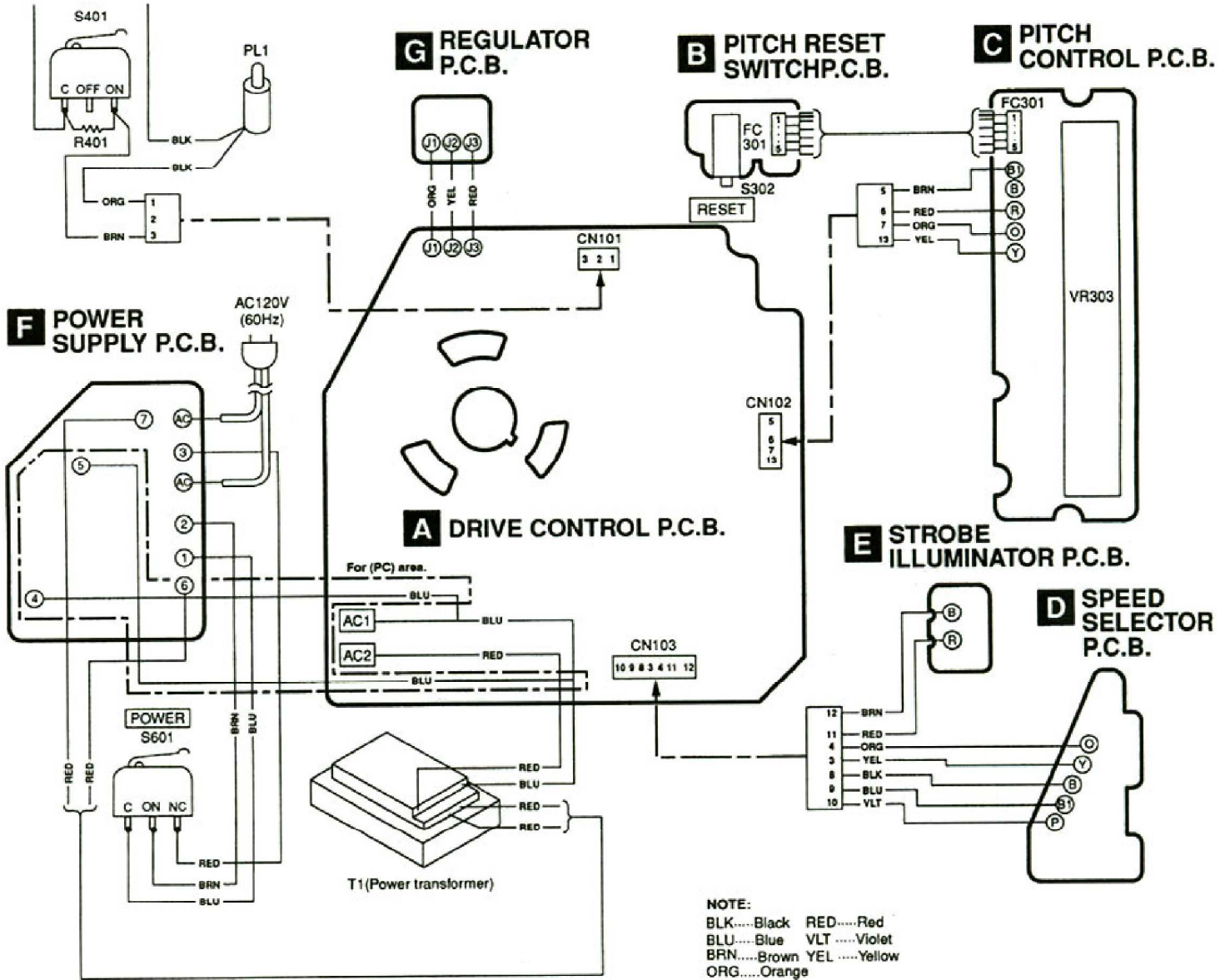

Fig. 2

Block Diagram



■ Wiring Connection Diagram



Replacement Parts List

Notes: * Important safety notice:

Components identified by  mark have special characteristics important for safety. Furthermore, special parts which have purposes of fire-retardant (resistors), high-quality sound (capacitors), low-noise (resistors), etc. are used.

When replacing any of components, be sure to use only manufacturer's specified parts shown in the parts list.

* All parts are supplied by MESA.

* The "<IA> <IB>" marks in Remarks indicate language of operating instructions.

<IA> : English

<IB> : Canadian French

Ref.No.	Part No.	Part Name & Description	Pcs	Remarks
1	SFAD122-01A	DUST COVER	1	
2	RGS0008	T/T RUBBER MAT	1	
3	SFTE172-01Z	TURNTABLE ASS'Y	1	
4	SFUM172-053	PANEL COVER	1	
5	SFMGQ20-01	DRIVE COIL COVER	1	
6	SFMG520-31A	DRIVE COIL ASS'Y	1	
7	SFMZ172-01E	FG COIL ASS'Y	1	
8	SFMZQ20-01A	SHAFT ASS'Y	1	
9	RFKN1200M3DP	POWER SW KNOB ASS'Y	1	
10	SFKT015-061	BUTTON,START/STOP	1	
11	SFKT015-011E	BUTTON,SPEED SELECTOR(33)	1	
12	SFKT015-021E	BUTTON,SPEED SELECTOR(45)	1	
13	SFDJ122-02E	WIRE ASS'Y	1	
14	SFDJ122-06E	WIRE ASS'Y	1	
15	RGK0942Z-S	COVER,STROBE ILLUMINATOR	1	
16	SFQA122-01	SPRING	1	
17	RMR1111A-K	BASE,OPERATION	1	
18	SFUM122-03	CAM,POWER SWITCH	1	
19	SFUM015-11	SPACER,LED	2	
20	SFYB5-32	BALL	1	
21	SFQA520-01	SPRING	1	
22	SFKK172-01	COVER,STYLUS ILLUMINATOR	1	
23	SFXB122-06	DRIVE BOSS	1	
24	SFQA172-01	SPRING	1	
25	SFXJ172-01	PIN,LOCK CANCELER	1	
26	SFQA520-011	SPRING	1	
27	SFX0172-01-1	PIN,GUIDE	1	
28	SFUP122-02E	BRACKET,ILLUMINATOR	1	
30	SFUP122-03	PLATE,LOCK OPERATION	1	
31	SFQA122-02	SPRING	1	
32	SFXJ172-05	PIN	1	
33	RMG0483-K	RUBBER,DUST COVER	2	
35	SFUP122-09	HOLDER,LED	1	
36	SFUP122-01	BRACKET,PITCH CONTROL	1	
37	SFDJ122-04E	WIRE ASS'Y	1	
38	SFUP122-15-1	STOPPER,SPRING	1	
40	RKM0101D-S	CABINET	1	
41	SFUM172-04	ORNAMENT,ILLUMINATOR	1	
44	SFUP122M12E2	AC CORD ASS'Y	1	
45	SFKT122-02	KNOB,PITCH CONTROL	1	
46	RGH0131-S1	ORNAMENT,PITCH CONTROL	1	
47	SFUZ122-01	FELT	1	
51	SFGC122-01	RUBBER	3	
53	SFAU122-032	BOTTOM COVER B	1	
54	SFAU122-022	BOTTOM COVER A	1	
55	RGN1655-K	NAME PLATE	1	P
55	RGN1656-K	NAME PLATE	1	PC
57	SFUP122-233	SUPPORTER(A)	2	
60	SFGC122-04E	INSULATOR	4	
70	SFPRT17201K	ARM REST	1	
71	RFKN1200MK2A	ARM BASE ASS'Y	1	
73	SFPKD12201	BRACKET,ARM BASE	1	
74	SFPAB17206	KNOB,ANTI-SKATING CONTROL	1	
76	SFPCC31005K	HEAD SHELL	1	
76-1	REZ1037-1	WIRE KIT	1	
77	P-AM18201K	TONEARM ASS'Y	1	
78	SFPWG17201K	BALANCE WEIGHT	1	
79	SFPRT18201K	ARM LIFT	1	
80	SFQA829-03	SPRING	1	

Ref.No.	Part No.	Part Name & Description	Pcs	Remarks
81	SFPAB13202	KNOB,LIFT	1	
82	SFPAB18201K	TONEARM FIXING PLATE	1	
83	SFPJL18202K	OIL DAMPER	1	
84	SFPZB12201K	PLATE	1	
85	SFPZB12203	PLATE,ARM BASE COVER	1	
86	SFUM170-06	SPACER,PHONO CORD	1	
87	SFPZB12204	CLAMPER,PHONO CORD	1	
88	RJL2P001B12	PHONO CORD	1	
89	SFEL026-01E1	GROUND WIRE	1	
90	SFPZB17202	KNOB,ARM LOCK	1	
91	N092	SPACER	1	
92	RGU0611-S	BUTTON,PITCH CONT.RESET	1	
93	RMR0945-K	PLATE,PITCH CONTROL.RESET	1	
94	RMX0124	SPACER	1	
96	SFGZ122-021	RUBBER	1	
98	SFXW172-032	SPACER,PITCH CONTROL	1	
99	REZ0836	FLAT CABLE	1	
101	SFUZ122-04	SHEET	1	
104	RMR1112-K	SHELL STAND	1	
105	RQLC0142	TECHNICS LABEL	1	
A1	RQT4912-P	O/I BOOK	1	PPC <IA>
A1	RQT4913-C	O/I BOOK	1	PC <IB>
A2	RQA0149	WARRANTY CARD	1	P
A2	SQX7183	WARRANTY CARD	1	PC
A3	SFWE010	EP record ADAPTOR	1	
A4	RHN26003	NUT,CARTRIDGE	2	
A5	SFCZV8801	SCREW,CARTRIDGE	2	
A6	SFPEV9801	SCREW,CARTRIDGE	2	
A7	SFPEW9601	WASHER	2	
A8	SFPZB3501	SHELL WEIGHT	1	
A9	SFPWG17202	AUXILIARY WEIGHT	1	
A10	SFK0135-01	OVERHANG GAUGE	1	
A11	RGS0005Z	DISC SLIP SHEET ASSY	1	
A12	RQLC0142	TECHNICS LABEL	1	
A13	RQCB0391	SERVICENTER LIST	1	P
A13	RQCB0832	SERVICENTER LIST	1	PC
△C1	ECA1HM471S	50V 470U	1	
C2	RCE1EU330BV	25V 33U	1	
C3	ECEA1EKA220B	25V 22U	1	
△C5,6	ECQM1223KZ3	125V 0.022U	2	
C101-03	RCE1EU330BV	25V 33U	3	
C104-07	ECQV1H104JM3	50V 0.1U	4	
C108	ECA1EM101	25V 100U	1	
C109,10	ECQV1H104JM3	50V 0.1U	2	
C111	ECQB1H562JF3	50V 5600P	1	
C112	RCE1HKA4R7BG	50V 4.7U	1	
C201	RCE1AKA330BG	10V 33U	1	
C202,03	ECEA1HKS010	50V 1U	2	
C204	ECQV1H473JM3	50V 0.047U	1	
C205	ECA0JM221	6.3V 220U	1	
C206	ECEA1HKS010	50V 1U	1	
C207	ECCR1H101K5	50V 100P	1	
C208	ECCR1H220KU5	50V 22P	1	
C209	RCE1AU101BV	10V 100U	1	
C210,11	ECQV1H224JM3	50V 0.22U	2	
C212	RCE1HKA3R3BG	50V 3.3U	1	
C213	ECCR1H471K5	50V 470P	1	
C214	RCE1AU101BV	10V 100U	1	
C215	ECEA1HKS010	50V 1U	1	
C216	RCE1AKA470BG	10V 47U	1	
C217-19	ECFR1H104ZF	50V 0.1U	3	
C201	ECQK1333GZ	125V 0.033U	1	
C302	ECQK1682GZ	125V 6800P	1	
C303	ECEA1HKS010	50V 1U	1	
C304	RCE1CKA100BG	16V 10U	1	
C305	ECQB1H122JF3	50V 1200P	1	
C306	ECEA1HKS010	50V 1U	1	
△C601	ECQU2A473MY	100V 0.047U	1	
CN101	EMCS0360L	CONNECTOR(3P)	1	
CN102	EMCS0460L	CONNECTOR(4P)	1	
CN103	EMCS0760L	CONNECTOR(7P)	1	

Ref.No.	Part No.	Part Name & Description	Pcs	Remarks
△D1	D2SBA20	DIODE	1	
△D3	MA4051M	DIODE	1	
D201_02	SVDPR3902S-9	LED	2	
D203_04	SVDEBR5505S	LED	2	
D204A	MA165	DIODE	1	
D205_06	SVDEBR5505S	LED	2	
△D301	MA4051M	DIODE	1	
D301A	GL8EG21	LED	1	
△F1	XBA1F12NU14	FUSE	1	PC
IC101	AN6675	IC.TURNTABLE DRIVE	1	
IC201	AN6680	IC.CONTROL	1	
IC301	AN6682	IC.PITCH CONTROL	1	
IC302	TC4011BP	IC.PCONT.ON/OFF SELECT	1	
N1	XTN3+8JFZ	SCREW	5	
N2	SFXGQ20-02	SCREW	3	
N3	XTW3+8T	SCREW	4	
N4	XTB3+8J	SCREW	13	
N5	SFXG172-01	SCREW	3	
N8	SNSB10	SCREW	3	
N9	XYN3+C6S	SCREW	2	
N10	XTN3+6J	SCREW	4	
N11	XWE4D10BW	WASHER	1	
N12	XTBS26+8J	SCREW	2	
N13	XUC25FY	WASHER	2	
N14	SFXW910J02	WASHER	1	
N16	XTB3+10JFZ	SCREW	4	
N17	XUC3FY	WASHER	2	
N18	XTV3+8G	SCREW	1	
N19	XSN17+3FY	SCREW	1	
N20	SFXW122-03	WASHER	1	
N21	XUC2FT	WASHER	1	
N22	XWE3D8	WASHER	1	
N23	XYN3+C15S	SCREW	1	
N24	RTW-12	WASHER	1	
N25	XSN2+10	SCREW	2	
N26	SFXG122-01	SCREW	4	
N27	SFXG122-02	SCREW	11	
N28	SNSB9-2	SCREW	6	
N29	XTW3+15T	SCREW	10	
N31	SFXG829-1	SCREW	1	
N32	XYN3+C10S	SCREW	2	
N33	XTW3+6T	SCREW	3	
N34	XWE4A10BW	WASHER	1	
N35	XTN3+25J	SCREW	1	
N36	XTB3+6JFZ	SCREW	2	
N37	XTW3+12TFZ	SCREW	2	
N38	XTN3+8J	SCREW	1	
N39	XTV23+10G	SCREW	1	
N40	XTN26+6J	SCREW	3	
N41	XWE3F6	WASHER	2	
N42	XUC5FY-V	WASHER	1	
N43	SFPEW17201	WASHER	1	
N44	XTW26+6S	SCREW	1	
P1	RPG4326	PACKING CASE	1	
P2	SFHH122-011	CUSHION.FRONT	1	
P3	SFHH122-02	CUSHION.REAR	1	
P4	SFHD122N05	PAD.TOP	1	
P5	SFHD122-02	PAD(A)	1	
P6	RPN0306	PAD(B)	1	
P7	RPH0133	PROTECTION SHEET	1	
P8	SFHZ122-01	PROTECTION SHEET	1	
P9	XZB60X65A01X	PROTECTION BAG	2	
P10	XZB45X50A01X	PROTECTION BAG	1	
P11	SFYF09A15	PROTECTION BAG	2	
P12	XZB05X06C03	PROTECTION BAG	2	
P14	XZB25X14C03X	POLYETHYLENE COVER	1	
P17	RPO0608	PAD.TONEARM	1	
PL1	SFDN122-01E	LAMP	1	

Ref.No.	Part No.	Part Name & Description	Pcs	Remarks
△Q1	2SD1265-0	TRANSISTOR	1	
△Q2,3	2SD637-QRS	TRANSISTOR	2	
△Q201	2SC1846-QRS	TRANSISTOR	1	
Q202	2SD637-QRS	TRANSISTOR	1	
Q203	2SC2458GR	TRANSISTOR	1	
R1	ERDS2FJ562	1/4W 5.6K	1	
R2	ERDS2FJ682	1/4W 6.8K	1	
R3	ERDS2FJ272	1/4W 2.7K	1	
R4,5	ERDS2FJ471	1/4W 470	2	
R101	ERDS2FJ103	1/4W 10K	1	
R102	ERX1SJ4R7	1W 4.7	1	
R103	ERDS2FJ472	1/4W 4.7K	1	
R104	ERDS2FJ473	1/4W 47K	1	
R105	ERDS2FJ103	1/4W 10K	1	
R106	ERDS2FJ150	1/4W 15	1	
R107	ERX1ANJ1R5H	1W 1.5	1	
R108	ERDS2FJ103	1/4W 10K	1	
R109,10	ERX1SJ4R7	1W 4.7	2	
R201	ERG1SJ561	1W 560	1	
R202	ERDS2FJ103	1/4W 10K	1	
R203	ERDS2FJ470	1/4W 47	1	
R204	ERDS2FJ272	1/4W 2.7K	1	
R205	ERDS2FJ124	1/4W 120K	1	
R206	ERDS2FJ183	1/4W 18K	1	
R207	ERDS2FJ563	1/4W 56K	1	
R208	ERDS2FJ224	1/4W 220K	1	
R209	ERDS2FJ334	1/4W 330K	1	
R210	ERDS2FJ183	1/4W 18K	1	
R211	ERDS2FJ472	1/4W 4.7K	1	
R212	ERDS2FJ151	1/4W 150	1	
R213	ERDS2FJ122	1/4W 1.2K	1	
R214	ERDS2FJ223	1/4W 22K	1	
R215	ERDS2FJ472	1/4W 4.7K	1	
R216	ERDS2FJ154	1/4W 150K	1	
R217	ERDS2FJ223	1/4W 22K	1	
R218	ERDS2FJ102	1/4W 1K	1	
R219	ERDS2FJ332	1/4W 3.3K	1	
R220	ERDS2FJ221	1/4W 220	1	
R221	ERDS2FJ471	1/4W 470	1	
R222	ERDS2FJ391	1/4W 390	1	
R301	ER0S2TKG2701	1/4W 2.7K	1	
R302	ERDS2FJ471	1/4W 470	1	
R303	ERDS2FJ822	1/4W 8.2K	1	
R304	ERDS2FJ561	1/4W 560	1	
R305	ERDS2FJ181	1/4W 180	1	
R306	ERDS2FJ223	1/4W 22K	1	
R307	ERDS2FJ272	1/4W 2.7K	1	
△R401	ERDS1FJ152	1/2W 1.5K	1	
△R601	ERDS1FJ4R7	1/2W 4.7	1	
S201_02	EVQPXR04K	SW.SPEED SELECTOR 33/45	2	
S203	SFDS5S01GL13	SW.START/STOP	1	
S301	SFDZ122N11-3	SW.PITCH CONTROL RESET	1	(VR303)
S302	RSP2B010-1J	SW.PITCH RESET	1	
S401	SFDS2MSL-C	SW.STYLUS ILLUMINATOR	1	
△S601	SFDS5S5GL13P	SW.POWER	1	
△T1	SLT66DT15C	POWER.TRANSFORMER	1	
VR201	EVMK3GA00B54	VR.BRAKE ADJ.	1	
VR301	EVMH1GA00B23	VR.PITCH CONTROL.0% ADJ.	1	
VR302	EVMK3GA00B54	VR.PITCH CONTROL GAIN ADJ	1	
VR303	SFDZ122N11-3	VR.PITCH CONT.ADJ.	1	(S301)
X201	RSXB4M13J01	X'TAL OSCILLATOR(4.13MHZ)	1	

■ Cabinet Parts Location

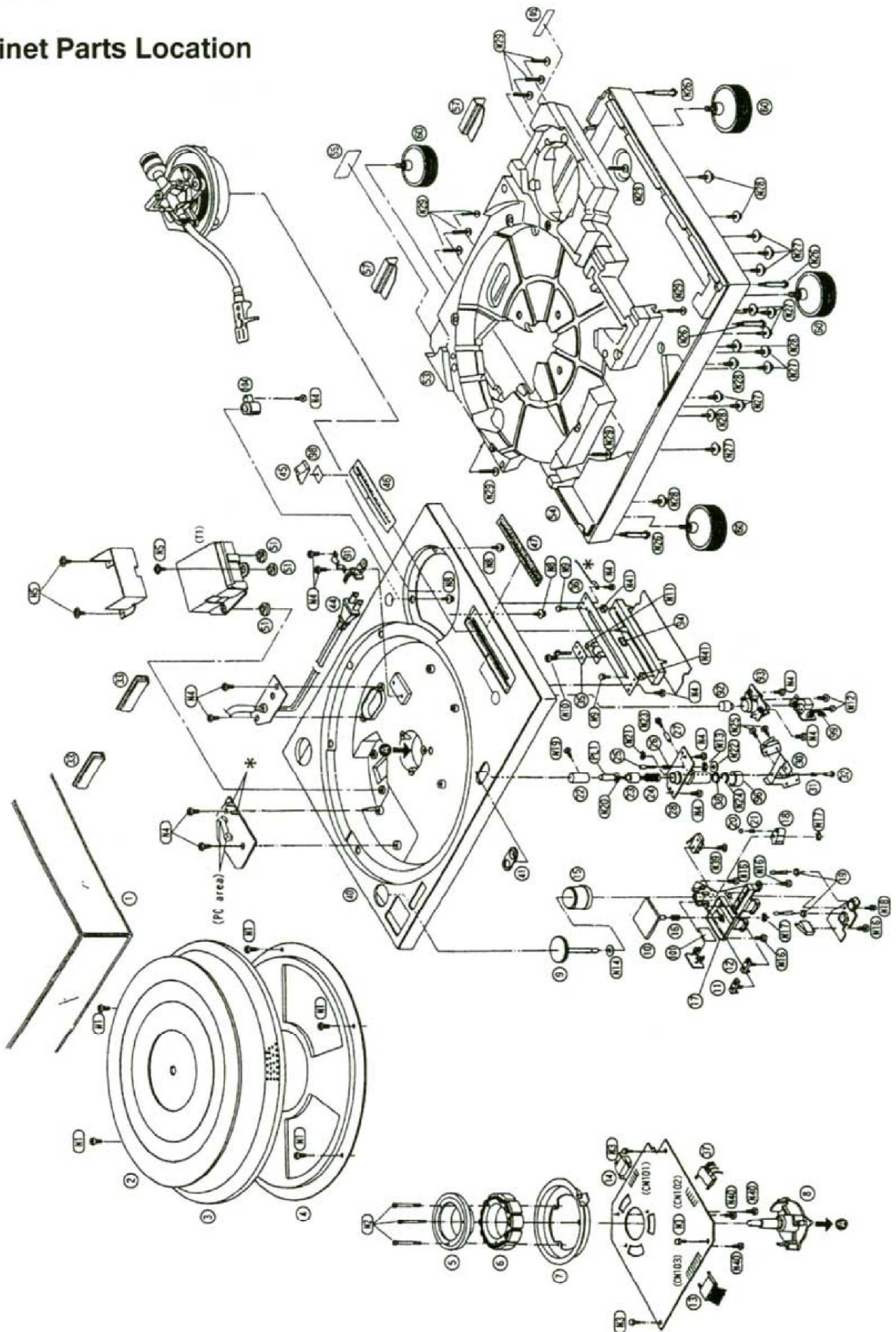

Ref.No.	Part No.	Part Name & Description	Pcs	Ref.No.	Part No.	Part Name & Description	Pcs	Ref.No.	Part No.	Part Name & Description	Pcs
1	SFAD122-01A	DUST COVER	1	7	SFMZ172-01E	FG COIL ASS'Y	1	14	SFDJ122-06E	WIRE ASS'Y	1
2	RGS0008	T/T RUBBER MAT	1	8	SFMZQ20-01A	SHAFT ASS'Y	1	15	RGK0942Z-S	COVER,STROBE ILLUMINATOR	1
3	SFTE172-01Z	TURNTABLE ASS'Y	1	9	RFKN1200M3DP	POWER SW KNOB ASS'Y	1	16	SFQA122-01	SPRING	1
4	SFUM172-053	PANEL COVER	1	10	SFKT015-061	BUTTON,START/STOP	1	17	RMR11111A-K	BASE,OPERATION	1
5	SFMGQ20-01	DRIVE COIL COVER	1	11	SFKT015-011E	BUTTON,SPEED SELECTOR(33)	1	18	SFUM122-03	CAM,POWER SWITCH	1
6	SFMG520-31A	DRIVE COIL ASS'Y	1	12	SFKT015-021E	BUTTON,SPEED SELECTOR(45)	1	19	SFUM015-11	SPACER,LED	2
				13	SFDJ122-02E	WIRE ASS'Y	1	20	SFYB5-32	BALL	1

● Tonarm section

We do not supply those items of parts marked *.

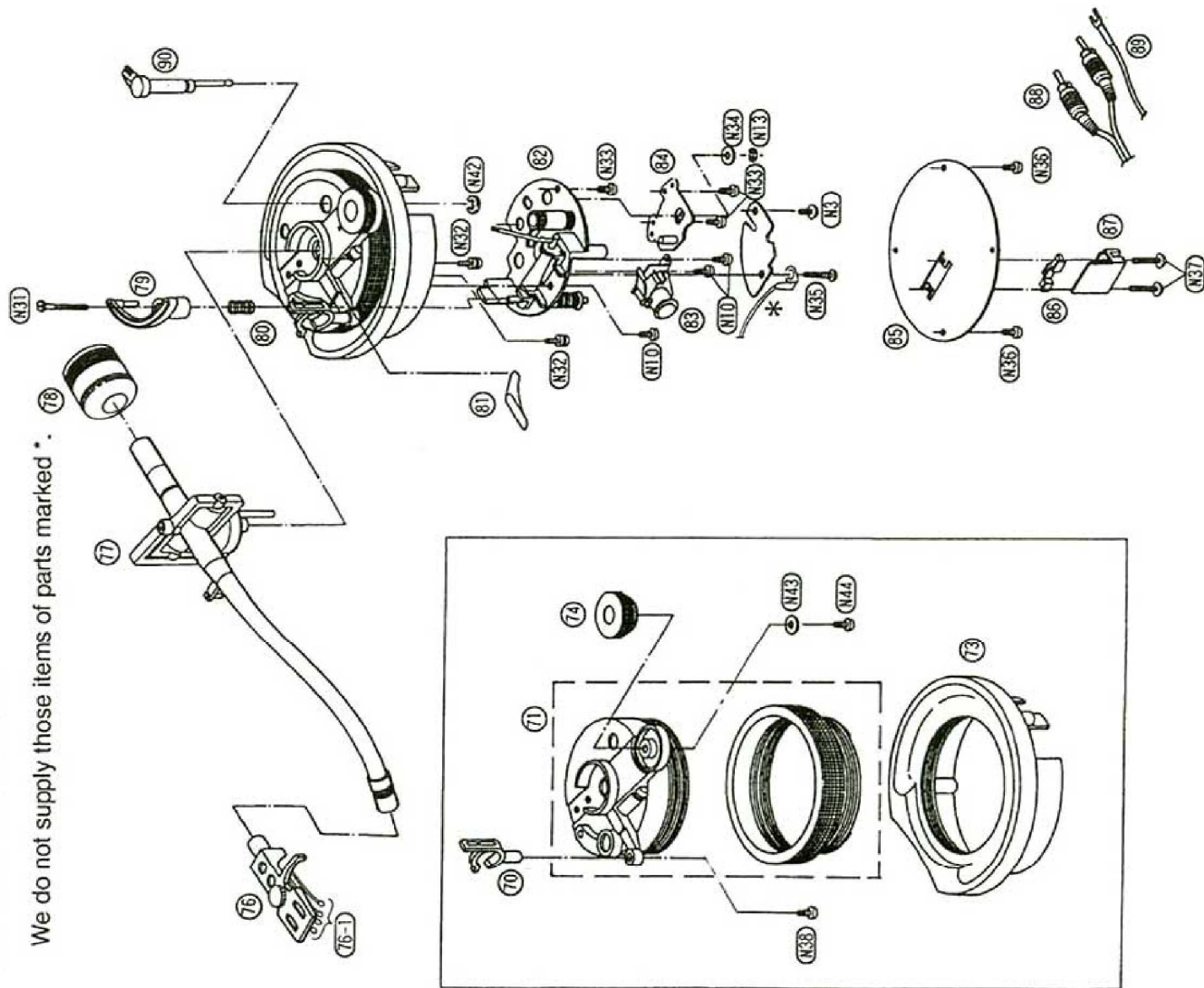

Ref.No.	Part No.	Part Name & Description	Pcs
21	SFQA520-01	SPRING	1
22	SFKK172-01	COVER,STYLUS ILLUMINATOR	1
23	SFXB122-06	DRIVE BOSS	1
24	SFQA172-01	SPRING	1
25	SFXJ172-01	PIN,LOCK CANCELER	1
26	SFQA520-011	SPRING	1
27	SFX0172-01-1	PIN,GUIDE	1
28	SFUP122-02E	BRACKET,ILLUMINATOR	1
30	SFUP122-03	PLATE,LOCK OPERATION	1
31	SFQA122-02	SPRING	1
32	SFXJ172-05	PIN	1
33	RMG0483-K	RUBBER,DUST COVER	2
35	SFUP122-09	HOLDER,LED	1
36	SFUP122-01	BRACKET,PITCH CONTROL	1
37	SFDJ122-04E	WIRE ASS'Y	1
38	SFUP122-15-1	STOPPER,SPRING	1
40	RKM0101D-S	CABINET	1
41	SFUM172-04	ORNAMENT,ILLUMINATOR	1
44	SFUP122M12E2	AC CORD ASS'Y	1
45	SFKT122-02	KNOB,PITCH CONTROL	1
46	RGH0131-S1	ORNAMENT,PITCH CONTROL	1
47	SFUZ122-01	FELT	1
51	SFGC122-01	RUBBER	3
53	SFAU122-032	BOTTOM COVER B	1
54	SFAU122-022	BOTTOM COVER A	1
55	RGN1655-K	NAME PLATE for U.S.A.	1
55	RGN1656-K	NAME PLATE for Canada.	1
57	SFUP122-233	SUPPORTER(A)	2
60	SFGC122-04E	INSULATOR	4
70	SFPRT17201K	ARM REST	1
71	RFKN1200MK2A	ARM BASE ASS'Y	1
73	SFPKD12201	BRACKET,ARM BASE	1
74	SFPAB17206	KNOB,ANTI-SKATING CONTROL	1
76	SFPCC31005K	HEAD SHELL	1

Ref.No.	Part No.	Part Name & Description	Pcs
76-1	REZ1037-1	WIRE KIT	1
77	P-AM18201K	TONEARM ASS'Y	1
78	SFPWG17201K	BALANCE WEIGHT	1
79	SFPRT18201K	ARM LIFT	1
80	SFQA829-03	SPRING	1
81	SFPAB13202	KNOB,LIFT	1
82	SFPAB18201K	TONEARM FIXING PLATE	1
83	SFPJL18202K	OIL DAMPER	1
84	SFPZB12201K	PLATE	1
85	SFPZB12203	PLATE,ARM BASE COVER	1
86	SFUM170-06	SPACER,PHONO CORD	1
87	SFPZB12204	CLAMPER,PHONO CORD	1
88	RJL2P001B12	PHONO CORD	1
89	SFEL026-01E1	GROUND WIRE	1
90	SFPZB17202	KNOB,ARM LOCK	1
91	N092	SPACER	1
92	RGU0611-S	BUTTON,PITCH CONTRRESET	1
93	RMR0945-K	PLATE,PITCH CONTROL RESET	1
94	RMX0124	SPACER	1
96	SFGZ122-021	RUBBER	1
98	SFXW172-032	SPACER,PITCH CONTROL	1
99	REZ0836	FLAT CABLE	1
101	SFUZ122-04	SHEET	1
104	RMR1112-K	SHELL STAND	1
105	RQLC0142	TECHNICS LABEL	1
N1	XTN3+8JFZ	SCREW	5
N2	SFXGQ20-02	SCREW	3
N3	XTW3+8T	SCREW	4
N4	XTB3+8J	SCREW	13
N5	SFXG172-01	SCREW	3
N8	SNSB10	SCREW	3
N9	XYN3+C6S	SCREW	2
N10	XTN3+6J	SCREW	4

Ref.No.	Part No.	Part Name & Description	Pcs
N11	XWE4D10BW	WASHER	1
N12	XTBS26+8J	SCREW	2
N13	XUC25FY	WASHER	2
N14	SFXW910J02	WASHER	1
N16	XTB3+10JFZ	SCREW	4
N17	XUC3FY	WASHER	2
N18	XTV3+8G	SCREW	1
N19	XSN17+3FY	SCREW	1
N20	SFXW122-03	WASHER	1
N21	XUC2FT	WASHER	1
N22	XWE3D8	WASHER	1
N23	XYN3+C15S	SCREW	1
N24	RTW-12	WASHER	1
N25	XSN2+10	SCREW	2
N26	SFXG122-01	SCREW	4
N27	SFXG122-02	SCREW	11
N28	SNSB9-2	SCREW	6
N29	XTW3+15T	SCREW	10
N31	SFXG829-1	SCREW	1
N32	XYN3+C10S	SCREW	2
N33	XTW3+6T	SCREW	3
N34	XWE4A10BW	WASHER	1
N35	XTN3+25J	SCREW	1
N36	XTB3+6JFZ	SCREW	2
N37	XTW3+12TFZ	SCREW	2
N38	XTN3+8J	SCREW	1
N39	XTV23+10G	SCREW	1
N40	XTN26+6J	SCREW	3
N41	XWE3F6	WASHER	2
N42	XUC3FY-V	WASHER	1
N43	SFPEW17201	WASHER	1
N44	XTW26+6S	SCREW	1

■ Packaging

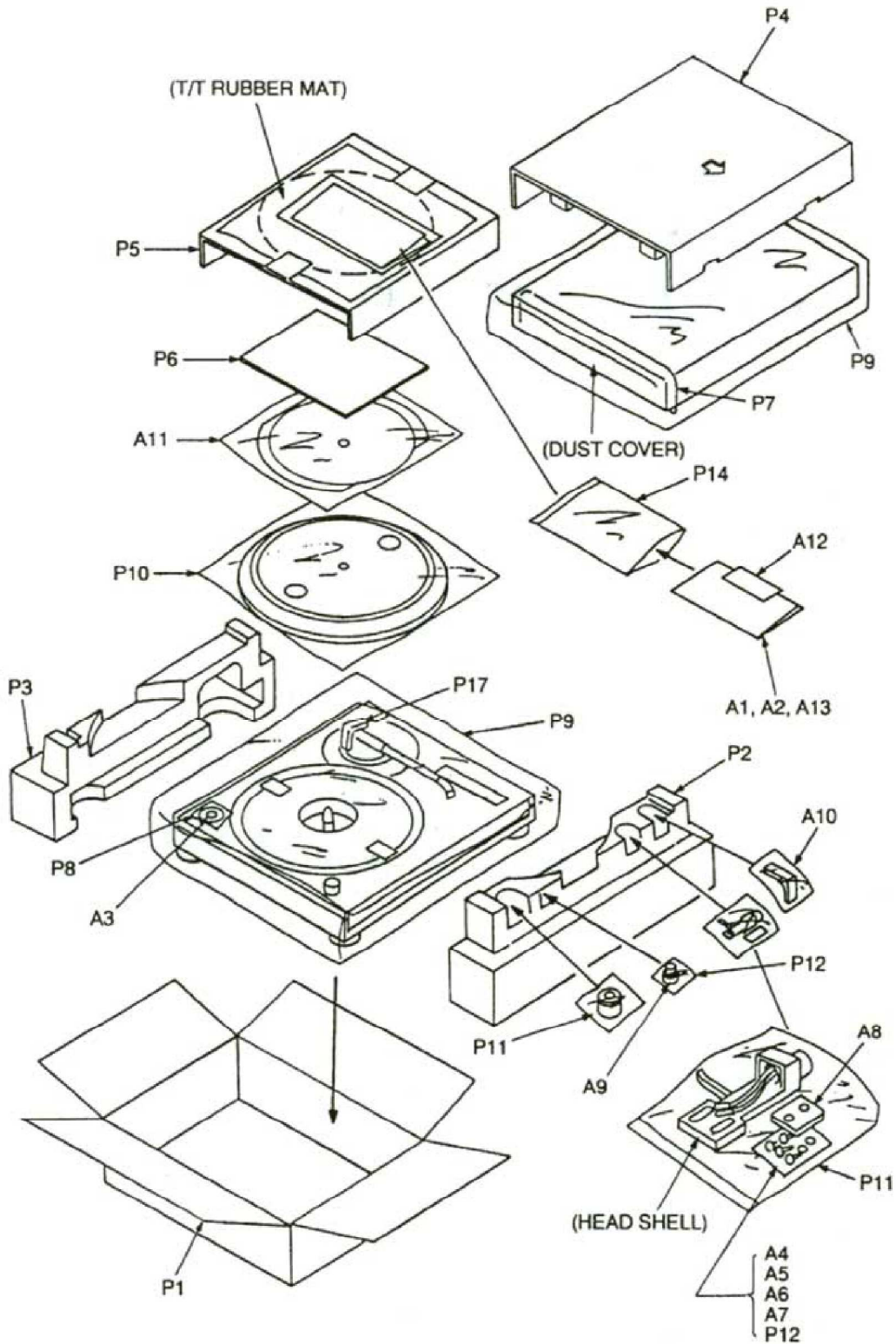

Ref.No.	Part No.	Part Name & Description	Pcs
A1	RQT4912-P	O/I BOOK	1
A1	RQT4913-C	O/I BOOK	1
A2	RQA0149	WARRANTY CARD	1
A2	SQX7183	WARRANTY CARD	1
A3	SFWE010	EP record ADAPTOR	1
A4	RHN26003	NUT,CARTRIDGE	2
A5	SFCZV8801	SCREW,CARTRIDGE	2
A6	SFPEV9801	SCREW,CARTRIDGE	2
A7	SFPEW9601	WASHER	2
A8	SFFZB3501	SHELL WEIGHT	1
A9	SFPWG17202	AUXILIARY WEIGHT	1
A10	SFK0135-01	OVERHANG GAUGE	1
A11	RGS0005Z	DISC SLIP SHEET ASSY	1
A12	RQLC0142	TECHNICS LABEL	1
A13	RQC80391	SERVICENTER LIST	1
A13	RQC80832	SERVICENTER LIST	1

Ref.No.	Part No.	Part Name & Description	Pcs
P1	RPG4326	PACKING CASE	1
P2	SFHH122-011	CUSHION_FRONT	1
P3	SFHH122-02	CUSHION_REAR	1
P4	SFHD122N05	PAD.TOP	1
P5	SFHD122-02	PAD(A)	1
P6	RPN0306	PAD(B)	1
P7	RPH0133	PROTECTION SHEET	1
P8	SFHZ122-01	PROTECTION SHEET	1
P9	XZB60X65A01X	PROTECTION BAG	2
P10	XZB45X50A01X	PROTECTION BAG	1
P11	SFYF09A15	PROTECTION BAG	2
P12	XZB05X06C03	PROTECTION BAG	2
P14	XZB25X34C03X	POLYETHYLENE COVER	1
P17	RPQ0608	PAD.TONEARM	1

Service Manual

Turntable System

Supplement

SL-1200LTD SL-1200M3D SL-1210M3D

Area

(P)	U.S.A.(SL-1200M3D only)
(PC)	Canada(SL-1200M3D only)
(E)	Europe(SL-1200LTD/1210M3D only)
(EG)	Germany, Italy(SL-1200LTD/1210M3D only)
(EB)	Great Britain(SL-1200LTD/1210M3D only)
(GN)	Oseania(SL-1210M3D only)

Subject : Change of parts (for the UL/CSA safety regulation).

This document is supplementary to the following Service Manuals.

Model No.	Area Code	Order No.	Brand
SL-1200LTD	(E,EB,EG)	AD9601011C2	Technics
SL-1200M3D	(P,PC)	AD9903091C1	Technics
SL-1210M3D	(E,EB,EG)	AD0104106A2	Technics
SL-1210M3D	(GN)	AD0108137C3	Technics

WARNING

This service information is designed for experienced repair technicians only and is not designed for use by the general public. It does not contain warnings or cautions to advise non-technical individuals of potential dangers in attempting to service a product. Products powered by electricity should be serviced or repaired only by experienced professional technicians. Any attempt to service or repair the product or products dealt with in this service information by anyone else could result in serious injury or death.

Technics

1 Change of suffix No.

Model name	Original Suffix No.	New Suffix No.
SL-1200M3D	B	C

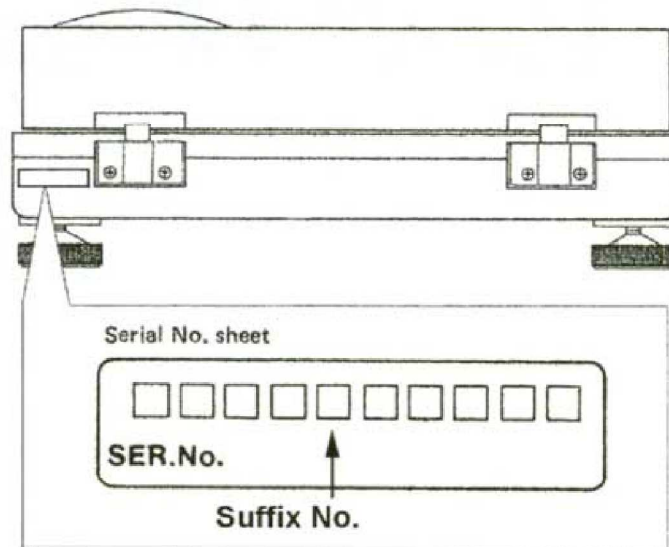

2 Replacement Part List

Ref. No.	Change of Parts No.		Part Name & Description	Remarks
	Original	Supplement		
CABINETS				
4	SFUM172-053	SFUM172-054	PANEL COVER	SL-1200M3D
17	RMR1111A-K	RMR1111B-K	BASE,OPERATION	SL-1200M3D
17	SFUM122-011	RMR1111B-K	BASE,OPERATION	SL-1200LTD
54	SFAU122-022	SFAU122-024	BOTTOM COVER A	SL-1200M3D
55	RGN1655-K	RGN1655-K2	NAME PLATE	SL-1200M3D (P)
55	RGN1656-K	RGN1656-K1	NAME PLATE	SL-1200M3D (PC)
ELECTRIC PARTS				
F1	XBA1F12NU14	K5D251AQ0002	FUSE 125V250mA	SL-1200M3D (PC)△
F1	—	K5D251AQ0002	FUSE 125V250mA	SL-1200M3D (P) △
F2	—	XBA1F12NU14	FUSE 125V1.2A	SL-1200M3D (P,PC) △

3 Schematic Diagram

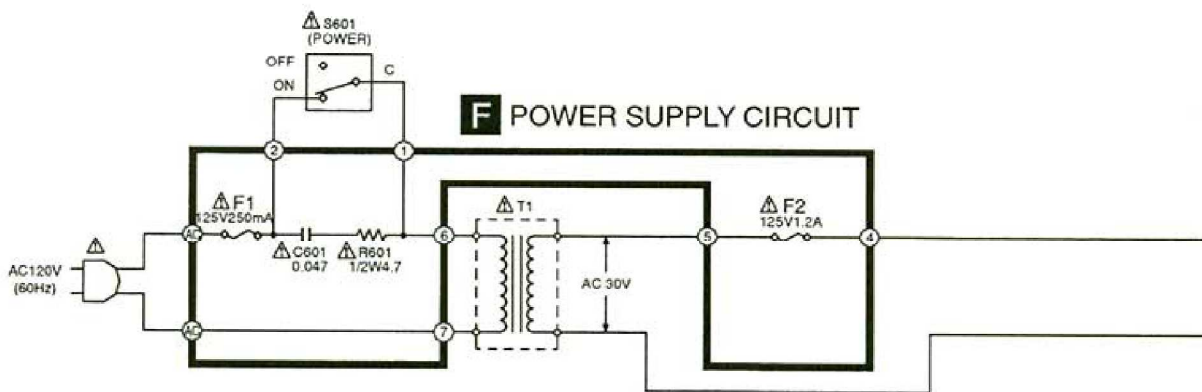

SL-1200M3D(P,PC) only

4 Printed Circuit Board

F POWER SUPPLY P.C.B.

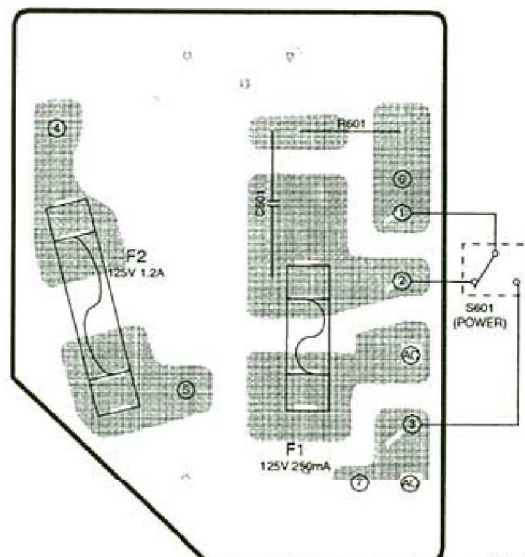

SL-1200M3D(P,PC) only