

Service Manual

Player

SL-20-(M)/SL-20A-(M)



SL-20-(M)

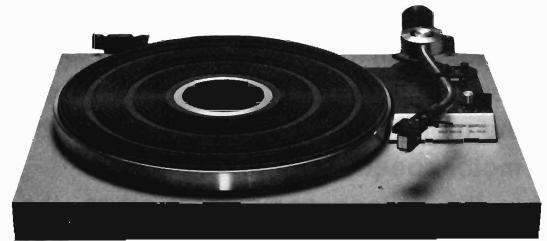

SL-20A-(M)

Simulated metal base

Specifications

TURNTABLE SECTION

Type: FREQUENCY GENERATOR SERVO
TURNTABLE Manual

Driving method: Belt drive

Motor: DC motor with FREQUENCY
GENERATOR SERVO

Turntable platter: Aluminium die-cast, 30cm (12") diameter

Turntable speeds: 33-1/3 and 45 r.p.m.

Wow and flutter: 0.05% W.R.M.S (JISC5521)

Rumble: -55 dB (IEC 179B), -40 dB (DIN 45539A),
-65 dB (DIN 45539B)

Speeds change method: Electronic change

TONARM SECTION

Type: Universal "S" shaped tubular arm, Static-
balanced type, Direct reading stylus
pressure adjustment.

Effective length: 220 mm (8-21/32")

Overhang: 14 mm (35/64")

Tracking error angle: Within +3° (at the point 145mm or 5-45/64"
from the center)
Within -0.2° (at the point 55 mm or
2-3/16" from the center)

Offset angle: 22°

Adjustable stylus
pressure range: 0 to 4g

Cartridge weight range: 3.0 to 8.5g

Headshell weight: 9.5g

GENERAL SECTION

Power supply: ~120V 50 or 60Hz

Power consumption: 2W

Dimensions (W×D×H): 42.8×34.8×13.5cm
16-55/64×13-45/64×5-5/16 inches

Weight: 5.0 kg (11 lb.)

* Specifications are subject to change without notice for further improvement.

Technics
by Panasonic

Matsushita Electric Corp. of America
50 Meadowlands Parkway, Secaucus, N.J. 07094

Matsushita Electric of Hawaii, Inc.
320 Waiakamilo Road, Honolulu, Hawaii 96817

Matsushita Electric of Canada Ltd.
40 Ronson Drive, Rexdale, Ont. M9W 1R5, Canada

OPERATING PRINCIPLES OF FREQUENCY GENERATOR SERVO MOTOR

- * A Frequency Generator is mechanically coupled to the motor shaft its output is in direct proportion to motor speed.
The signal produced by the Frequency Generator is amplified and converted to a square wave by the pulse shaper circuit.
- * The square wave is then converted into a trigger pulse.
- * A square wave of fixed amplitude (E_s) and width (T_s) is generated using the trigger pulse to determine the square wave frequency. Therefore, this square wave has a frequency (T) which is directly related to the speed of the motor.
- * An integrated circuit converts this square wave into a ramp wave which is used as the motor control voltage. (E_i) If the motor speed is too fast, the output of the Frequency Generator will be higher than normal causing a decrease in the period (T) of the square wave signal. This results in an increase in the motor control voltage (E_i). Thus the motor control voltage (E_i) is also in direct proportion to the motor speed.
- * In the voltage comparator stage, the motor control voltage (E_i) is compared with the reference control voltage E_s/n which is supplied from the reference voltage supply and divider circuits.
- * The output of the comparator (E_c) is the actual motor control voltage which will adjust the motor speed based on the signal supplied by the Frequency Generator.
- * A phase compensator is used to feed back the AC component of the motor drive voltage to the voltage comparator, to improve speed stability.

SPEED SELECTION

The two playing speeds are selected by varying the square wave pulse width (T_s) with two variable resistors.

LOAD CHARACTERISTICS (Fig. 15)

- * This chart indicates the fluctuation of the rotational speed of the turntable in relation to the stylus pressure values.
- * This unit employs a DC motor with an FREQUENCY GENERATOR SERVO circuit so that the load characteristics are extremely good.

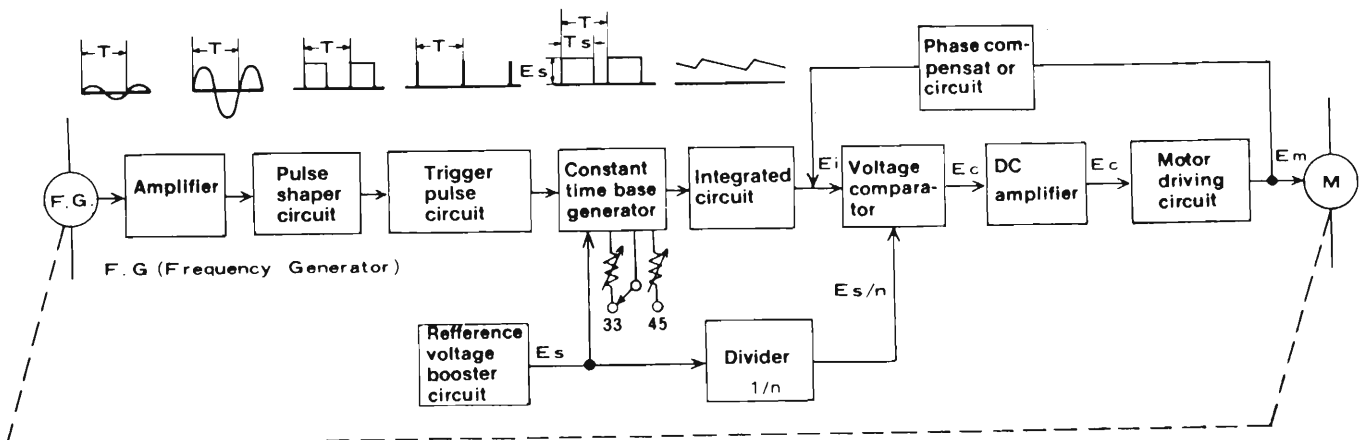
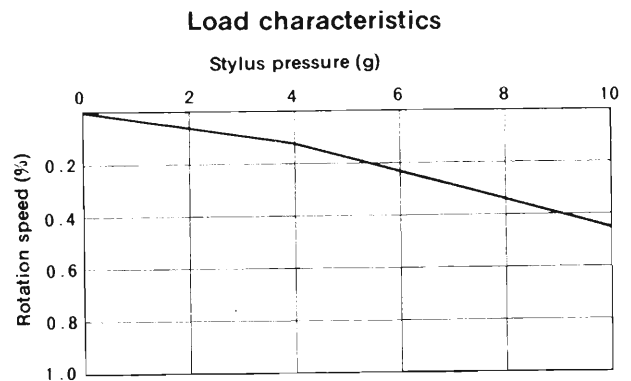

Fig. 1

ADJUSTMENT INSTRUCTION

1. THE ARM LIFT HEIGHT (CUEING LEVER)

- * The space between the stylus tip and record surface, when the cueing lever is raised, has been adjusted from 8 to 13 mm (5/16" to 1/2").
- * If, for any reason, it is not correct, turn the adjusting screw clockwise or counterclockwise while pushing down on the arm lift (See Figs. 2 and 3).

NOTE:

- * Be sure to push down on the arm lift when you turn this screw.
Clockwise to lower the arm.
Counterclockwise to raise the arm.

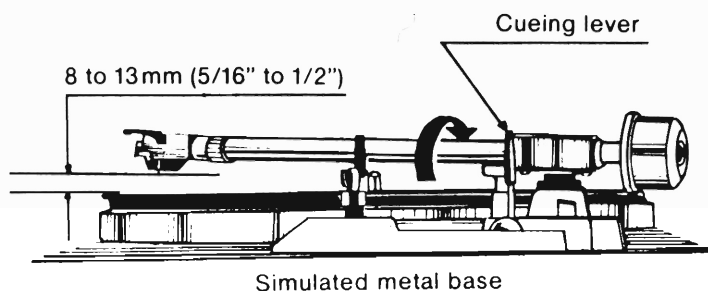

Fig. 2

2. SPEED ADJUSTMENT

- * This unit has been pre-adjusted at the factory.
- * If, for any reason, you wish to change the speed, turn these controls with a screwdriver to the "—" (increase) or "+" (decrease) direction as desired.

NOTE:

- * A speed strobe disc will assist you in setting the exact speed in each range.

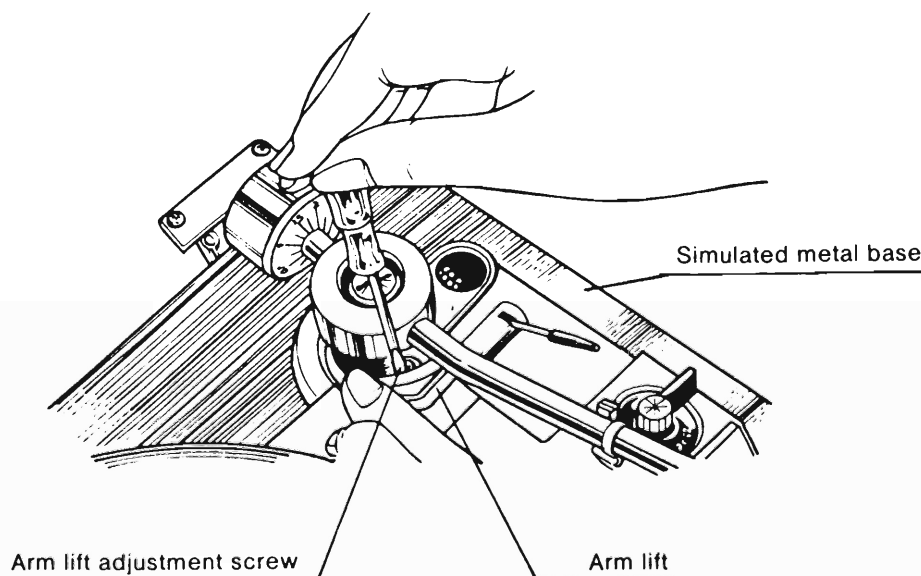
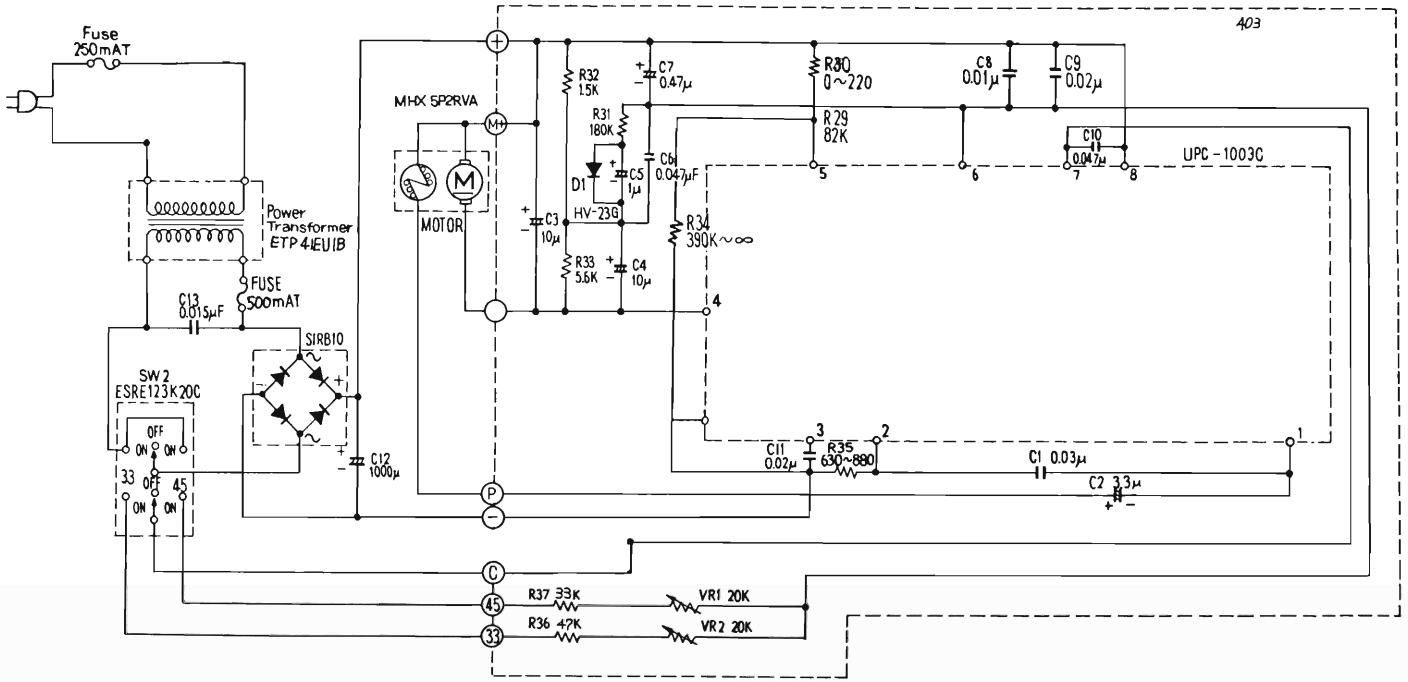
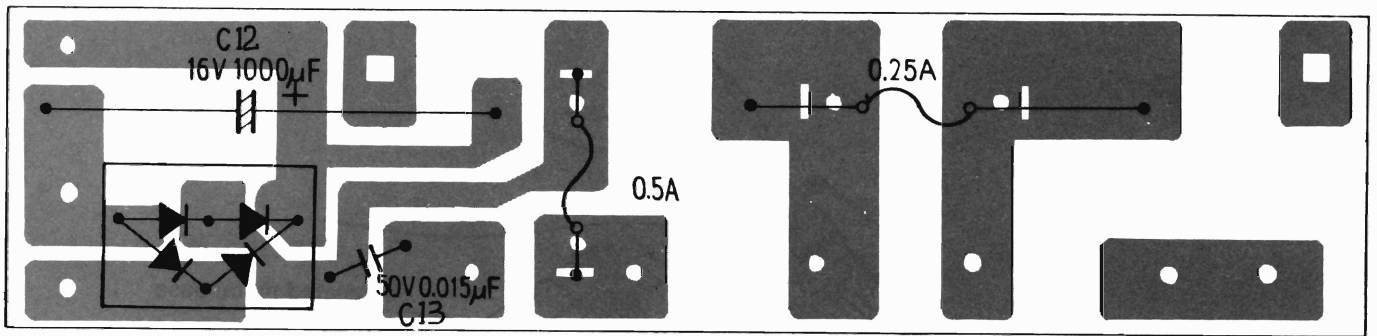

Fig. 3

SCHEMATIC DIAGRAM



CIRCUIT BOARD



TROUBLE SHOOTING GUIDE

* Except when checking voltage, disconnect the power cord before repair without fail.

TROUBLE	CAUSE	REMEDY
Turntable speed A. Switching on does not cause turntable to rotate.	<ol style="list-style-type: none"> 1. Come off belt from capstan (Remove bottom cover and, using DC voltmeter, check printed base voltage) 2. No output of constant-voltage circuit (1) No output on secondary of transformer. <ul style="list-style-type: none"> * Cord disconnected. * Soldered improperly. * Fuse disconnected. * Power transformer defective. 3. Output of constant-voltage circuit is 9.6~14.4V. <ul style="list-style-type: none"> * Motor ass'y defective. 4. Speed selector switch defective <ul style="list-style-type: none"> * Contact faulty. * Soldered improperly. 	Install the belt to capstan. <ul style="list-style-type: none"> * Replace cord. * Solder securely. * Replace fuse. * Replace power transformer. * Replace motor ass'y. * Replace speed selector switch. * Solder securely.
B. Turntable speed too slow.	<ol style="list-style-type: none"> 1. Constant-voltage output is not 9.6V~14.4V. <ul style="list-style-type: none"> * Power transformer defective. 2. Constant voltage output is 9.6V~14.4V. <ul style="list-style-type: none"> * Motor ass'y defective. * Speed unadjusted. 	<ul style="list-style-type: none"> * Replace power trans. * Replace motor ass'y. * Adjust semi-fixed resistor VR1 & VR2.
C. Turntable speed too fast.	<ol style="list-style-type: none"> 1. Constant-voltage output is not 9.6V~14.4V. <ul style="list-style-type: none"> * Power transformer defective. 2. Constant-voltage output is 9.6V~14.4V. <ul style="list-style-type: none"> * Motor ass'y defective. * Speed unadjusted. 	<ul style="list-style-type: none"> * Replace power transformer. * Replace motor ass'y. * Adjust semi-fixed resistor VR1 & VR2.
D. Turntable speed varies too much.	<ul style="list-style-type: none"> * Motor ass'y defective. * Belt defective. 	<ul style="list-style-type: none"> * Replace motor ass'y. * Replace belt.
E. Turntable, after stopped by hand, will not turn or starts turning but will stop soon.	<ul style="list-style-type: none"> * Motor ass'y defective. 	<ul style="list-style-type: none"> * Replace motor ass'y.
F. Operative at only one of two speeds. (33-1/3 r.p.m or 45 r.p.m)	<ul style="list-style-type: none"> * Speed selector switch defective. * Leadwire disconnected or unsoldered. * Contact of VR1, VR2 insufficient. 	<ul style="list-style-type: none"> * Replace speed selector switch. * Replace leadwire, or solder securely. * Replace printed base ass'y.
G. When actuating, turntable speed is unsteady for a long time.	<ul style="list-style-type: none"> * Motor ass'y defective. 	<ul style="list-style-type: none"> * Replace motor ass'y.
Noise Offensive noise is heard.	<ul style="list-style-type: none"> * Power transformer makes loud noise of vibration. 	<ul style="list-style-type: none"> * Replace power transformer.

PARTS LIST

NO.	PART NO.	DESCRIPTION	Q'TY	NO.	PART NO.	DESCRIPTION	Q'TY
1	SFAC020M01	Player case	1	14-6	SFPSP12002	Spring for the anti-skating force control	1
2	SFAU020L01	Bottom board	1	14-7	XTN3+16B	Screws for installation of the arm base	5
2-1	XMS27+13FVC	Screws for bottom board	10	14-8	XWE3E10	Washers for installation of the arm base	5
3	SFGA020L01E	Audio insulators	4	15	SFPRT22001K	Arm rest	1
3-1	XMM31+16	Screws for audio insulators	4	15-1	XNG26HBN	Nut for installation of the arm rest	1
4	SFAD020M01	Dust cover assembly	1	15-2	XWA26B	Spring washer for installation of the arm rest	1
4-1	SFKK020X01	Badge for dust cover	1	16	SFPRT13003K	Arm lift	1
4-2	SFGC040L1	Cushions for dust cover	2	16-1	SFQA829-3	Spring for the arm lift	1
5	SFAT020L01	Hinges	2	16-2	SFXG829-1	Arm lift high adjustment screw	1
5-1	SFXG020L01	Screws for dust cover installation	4	16-3	SFPAB13008K	Lift base ass'y	1
5-2	XMM31+10FZ	Screws for hinges installation	8	16-8	XTN3+5B	Screws for installation of the lift base	2
6	SFUK020L01A	Motor plate assembly	1	16-9	XTN3+8B	Screws for installation of the lift base	1
6-4	XMM31+13	Screws for installation of the motor plate	4	16-10	SFPJL22001K	Cueing lever	1
6-5	XSN3+16S	Screw for installation of the motor plate	1	16-11	SFPGM22001	Cueing rubber	1
6-6	XWC3BFM	Toothed lock washer for installation of the motor plate	1	17	SFUP890B01E	PU bearing	1
7	SFMC023L01E	Motor assembly (W/P.C.B and Capstan)	1	17-1	SFPEW3500	PU thrust washer	1
7-2	SFXG023L01	Stud for installation of the motor	3	17-2	SFPEW22001	PU thrust washer	1
7-6	SFGC020L01	Cushions for installation of the motor	3	17-3	SFPJD22002	PU stopper	1
7-7	XTV3+8B	Screws for installation of the print base of the motor	2	17-4	SFXG623-1	Screws for fixing the tonearm unit	1
8	ESRE123K20C	Speed selector switch	1	17-5	SFXN623-1	Nuts for PU stopper	2
9	SFTE020-01	Turntable platter	1	18	SFKK020M01	Accessory plate	1
9-1	SFTG829-02	Turntable mat	1	19	SFKT020L01E	Speed selector knob	1
9-2	SFGB029-1	Belt	1	20	SGB489	Badge	1
9-3	SFTK829-01	Ornamental plate, turntable mat	1	ACCESSORY PARTS			
10	SFDP020C01A	Power source print base assembly	1	A1	SFNU020M01	Instructions book (for SL-20-(M))	1
10-1	SVDS1RB10	Rectifier	1	A1-1	SFNU020A1	Instructions book (for SL-20A-(M))	1
10-2	XBAS2B0201	Fuse	1	A2	RQX9028A	Product service guide	1
10-3	XMM31+8	Screws for installation of the power source print base assembly	2	A3	SFWE154A1	45 r.p.m. adaptor	1
10-4	ECEB16V1000L	Condenser	1	A4	SFWS020X01	Strodo sheet	1
10-5	XBAS2B0501	Fuse	1	A5	SFKO135M01E	Overhang gauge	1
10-6	SFNZ020C04	Fuse label	1	A5-1	SFPZB13006	Shell spacer	1
10-7	ECQM05153KZ	Condenser	1	A5-2	SFPEV11005	Overhang adjustment screw	1
11	ETP41EU1B	Power transformer	1	A5-3	SFPEW9601	Washer	1
11-1	XNG3HS	Nut for installation of the transformer	1	A5-4	XNG26FBN	Nut	1
11-2	XWA3BFM	Spring washer for installation of the transformer	1	A6	SFCZV8800	Screws for cartridge [for SL-20-(M)]	2
11-3	XMM31+8	Screw for installation of the transformer	1	A7	SFPEV7800	Screw for cartridge [for SL-20-(M)]	2
12	SFDH020L01	Phono cable	1	A8	EPC78SMED	Cartridge [for SL-20A-(M) only]	1
12-1	SFDP020L02	PU print base	1	A9	EPS35STED	Stylus [for SL-20A-(M) only]	1
12-2	XTN3+10B	Screw for installation of the PU print base	1	PACKING MATERIALS			
12-3	SFEL028-01E	Ground wire	1	P2	SFHP020E01	Inside packing case	1
12-4	SFUM020L01	Board for installation of the phono cable	1	P3	SFHD020L01	Upper board	1
12-5	XMM31+20	Screws for installation of the board	2	P4	SFHZ055-01	Side pad	1
12-6	SFUP020L03	Supporting board for the AC cord and phono cable	1	P5	SFHH020L01	Corner pad A	2
12-7	XMM31+13	Screws for installation of the supporting board	2	P6	SFHH020L02	Corner pad B	2
12-8	RJA10C	Power cord	1	P7	SFHD020X01	Part box (for SL-20-(M) only)	2
12-9	SFHK040L	Bushing for fixing the cord	1	P8	SFHD020L02	Lid for part box	2
12-10	SFSR4N4	Bushing for fixing the phono cable	1	P9	SFYC100A130	Polyethylene sheet for unit	1
12-11	SFUP020L01	Shield case	1	P10	SFYF15A20	Polyethylene bag for AC cord and phono cable	1
12-12	XTV3+6B	Screws for installation of the shield case	2	P11	XSN6D40	Turntable platter clamping screws	2
12-13	XWE3E10	Washer for installation of the PU print base	1	P12	SFHS327S	Spacers for turntable platter	2
13	SFPAM22004K	Tonearm unit	1				
13-1	SFPWG22001K	Balance weight	1				
13-2	SFPCC13001K	Head shell	1				
14	SFPKD22001	Arm base	1				
14-1	SFPJK22001	Anti-skating force control knob	1				
14-2	SFPSH22001	Suspension for the anti-skating force control spring	1				
14-3	SFXW303-1	TEFLON washers for installation of the antiskating force control knob	2				
14-4	SFPEW12002	Washer for installation of the anti-skating force control knob	1				
14-5	XTW26+5D	Screw for installation of the suspension	1				

EXPLODED VIEW OF CHANGER

Model SL-20-(M)
Model SL-20A-(M)

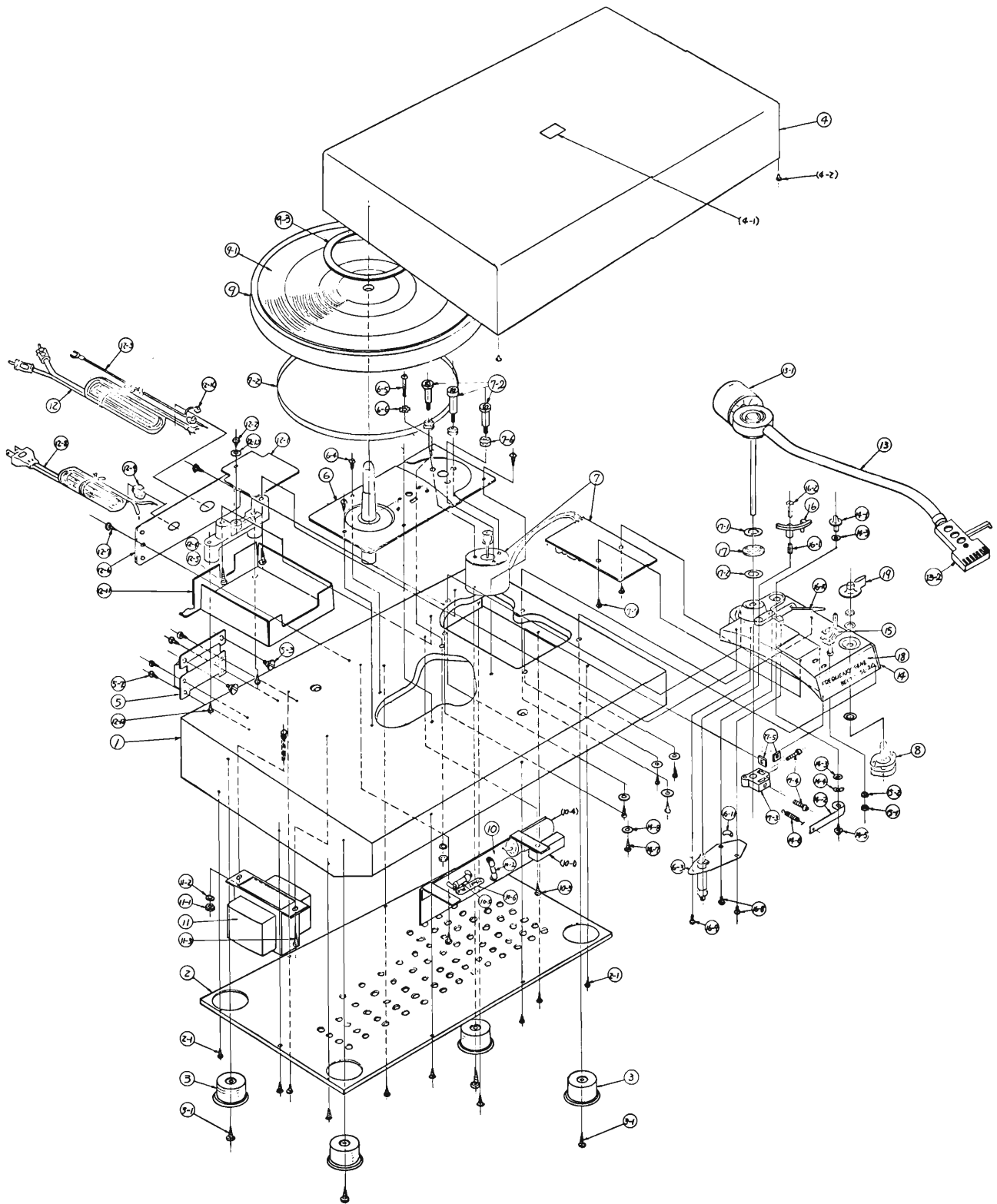

COMPONENT PACKING PROCEDURE

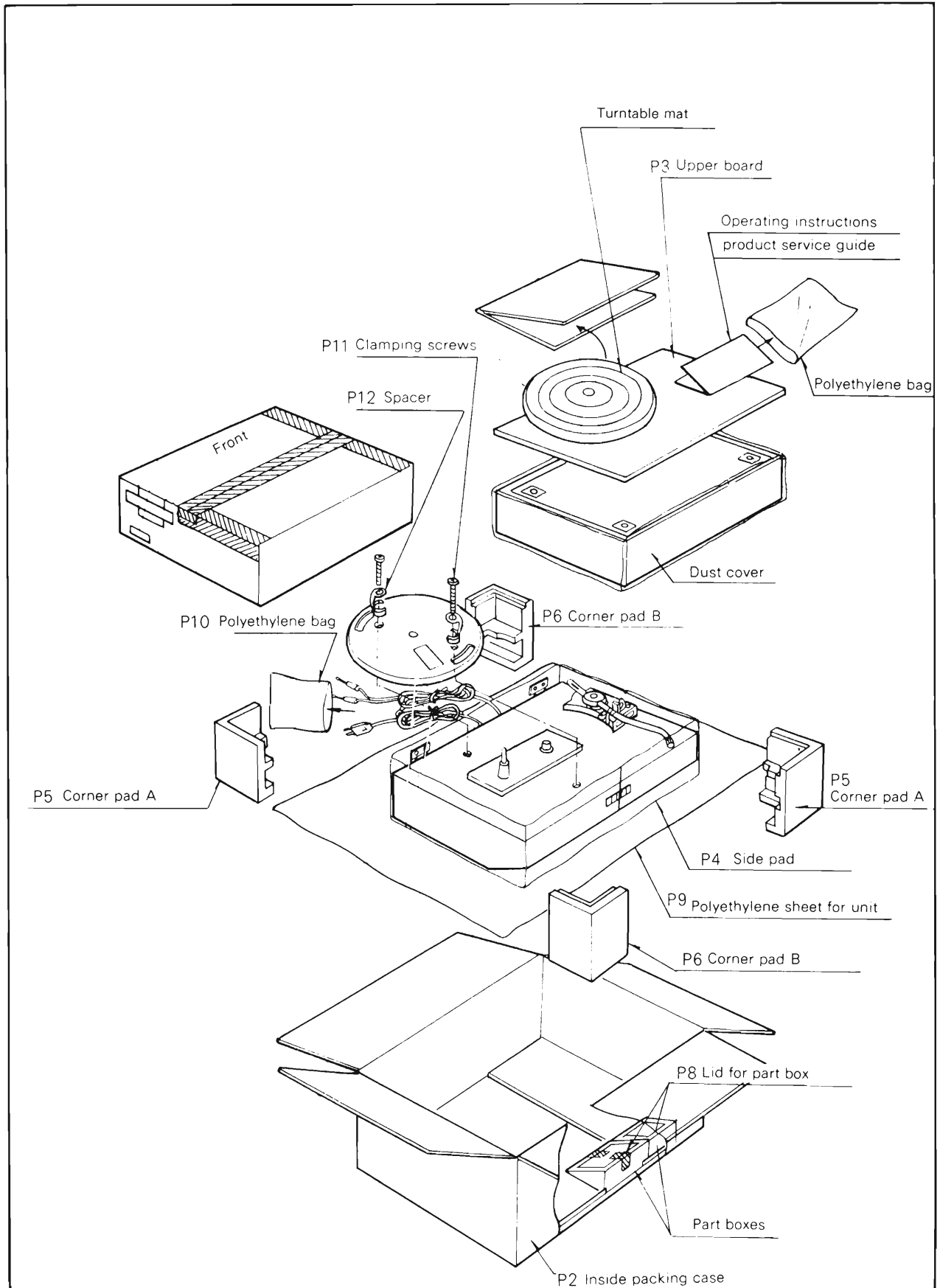

Service Manual

Player

SL-20 AND SL-23

Supplementary-2

For additional information, please refer to the service manual for Model SL-20A-(M),SL-20-(M),SL-20-(MC) and SL-23A-(M),SL-23-(M),SL-23-(MC).

Subject: Packing materials and Turntable mat modification.

Both old and new parts are not interchangeable

SL-20 MODIFICATION OF PARTS NO.

○ Deletion
● Additional

Ref.No.	Part No.		Description	Q'TY	Remarks
	OLD	NEW			
P2	SFHP020E01	SFHP020M02	Inside Packing Case	1	SL-20A-(M),SL-20-(M)
P2	SFHP020C01	SFHP020C02	Inside Packing Case	1	SL-20-(MC)
P3	SFHD020L01	SFHD023L02	Upper board	1	SL-20A-(M),SL-20-(M,MC)
P4	SFHZ055-1	SFHZ023L01	Side Pad	1	SL-20A-(M),SL-20-(M,MC)
P5	SFHH020L01	SFHH023L03	Coner Pad (Front Right)	1	SL-20A-(M),SL-20-(M,MC)
P5-1	SFHH020L01	SFHH023L04	Coner Pad (Rear Right)	1	SL-20A-(M),SL-20-(M,MC)
P6	SFHH020L02	SFHH023L01	Coner Pad (Front Left)	1	SL-20A-(M),SL-20-(M,MC)
P6-1	SFHH020L02	SFHH023L02	Coner Pad (Rear Left)	1	SL-20A-(M),SL-20-(M,MC)
P7	SFHD020X01	SFHH023L05	PartS Box	1	SL-20A-(M),SL-20-(M,MC)
P8	SFHH020L03	○	Parts Box	1	SL-20A-(M),SL-20-(M,MC)
P14	●	SFHD023M01	Top lid,Parts Box	1	SL-20A-(M),SL-20-(M,MC)

SL-23 MODIFFICATION OF PART NO.

○ Deletion
● Additional

Ref.No.	Part No.		Description	Q'TY	Remarks
	OLD	NEW			
P2	SFHP023M01	SFHP023M02	Inside Packing Case	1	SL-23A-(M),SL-23-(M)
P2	SFHP023C01	SFHP023M02	Inside Packing Case	1	SL-23-(MC)
P3	SFHD020L01	SFHD023L02	Upper board	1	SL-23A-(M),SL-20-(M,MC)
P4	SFHZ055-01	SFHZ023L01	Side Pad	1	SL-23A-(M),SL-20-(M,MC)
P5	SFHH020L01	SFHH023L03	Coner Pad (Front Right)	1	SL-23A-(M),SL-20-(M,MC)
P5-1	SFHH020L01	SFHH023L04	Coner Pad (Rear Right)	1	SL-23A-(M),SL-20-(M,MC)
P6	SFHH020L02	SFHH023L01	Coner Pad (Front Left)	1	SL-23A-(M),SL-20-(M,MC)
P6-1	SFHH020L02	SFHH023L02	Coner Pad (Rear Left)	1	SL-23A-(M),SL-20-(M,MC)
P7	SFHD020X01	SFHH023L05	Parts Box	1	SL-23A-(M),SL-20-(M,MC)
P8	SFHH020L03	○	Parts Box	1	SL-23A-(M),SL-20-(M,MC)
P14	●	SFHD023M01	Top lid,Parts Box	1	SL-23A-(M),SL-20-(M,MC)

NEW COMPONENT PACKING PROCEDURE
FOR MODELS SL-20 AND SL-23.

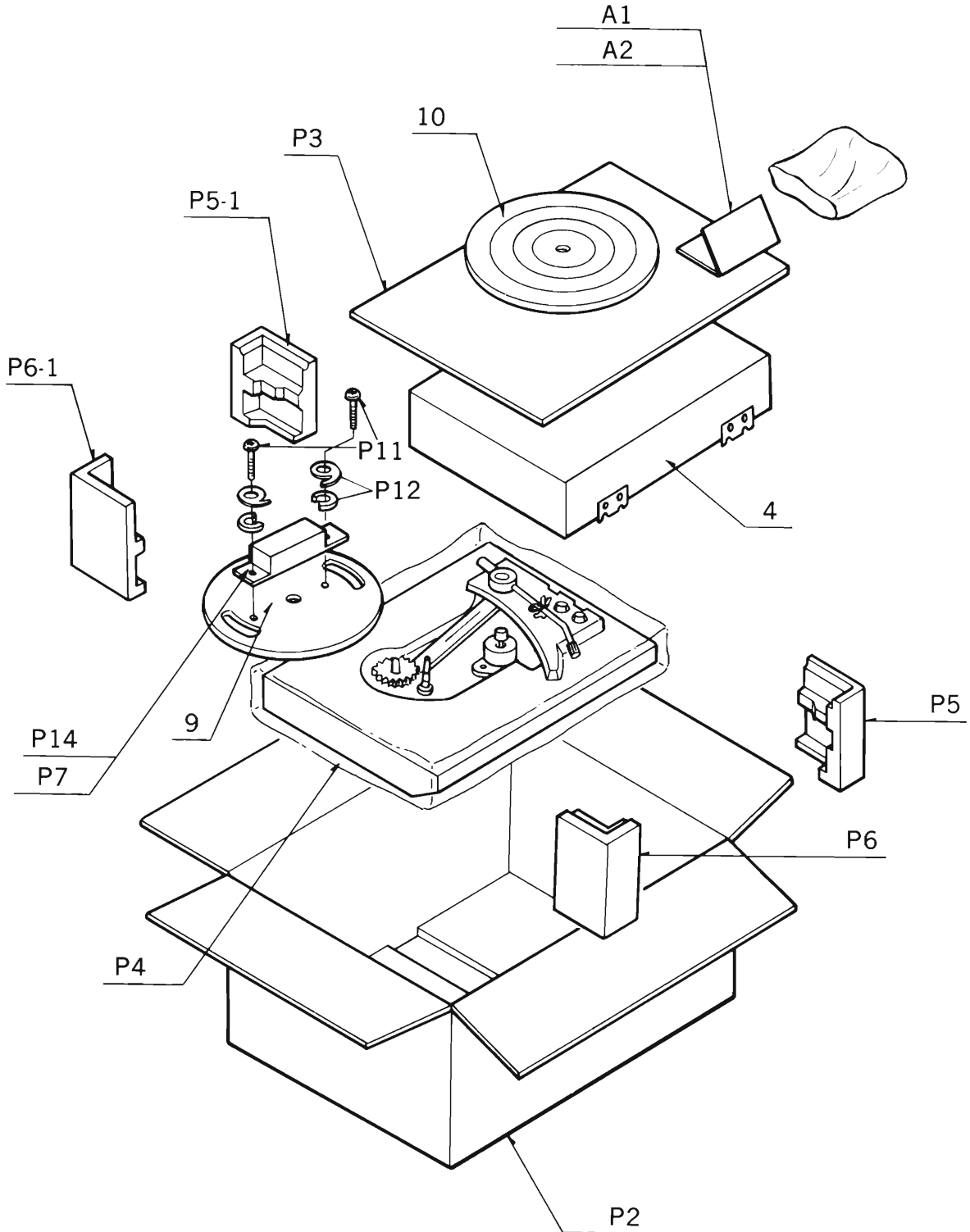

Technical Information

MODEL SL-20, SL-23

SUBJECT: Separate motor and the F.G. SERVO P.C.B.

REPLACEMENT PARTS LIST

OLD				NEW			
NO.	PART NO.	DESCRIPTION	Q'TY	NO.	PART NO.	DESCRIPTION	Q'TY
7	SFMC020L01E SL-20	Motor ass'y (w/capstan & P.C.B.)	1	VR1, 2	EVN31AA00B24	Variable resistor	2
6	SFMC023L01E SL-23	Motor ass'y (w/capstan & P.C.B.)	1	6-7	SFMH825B01R	Motor (w/capstan)	1
				6-8	FE-EGA462	P.C.B. ass'y	1

NOTE: See the Schematic Diagram (the reverse side)

CAUTION: If the DC power supply is connected to points \oplus and \ominus on the circuit board incorrectly, the IC will be damaged.

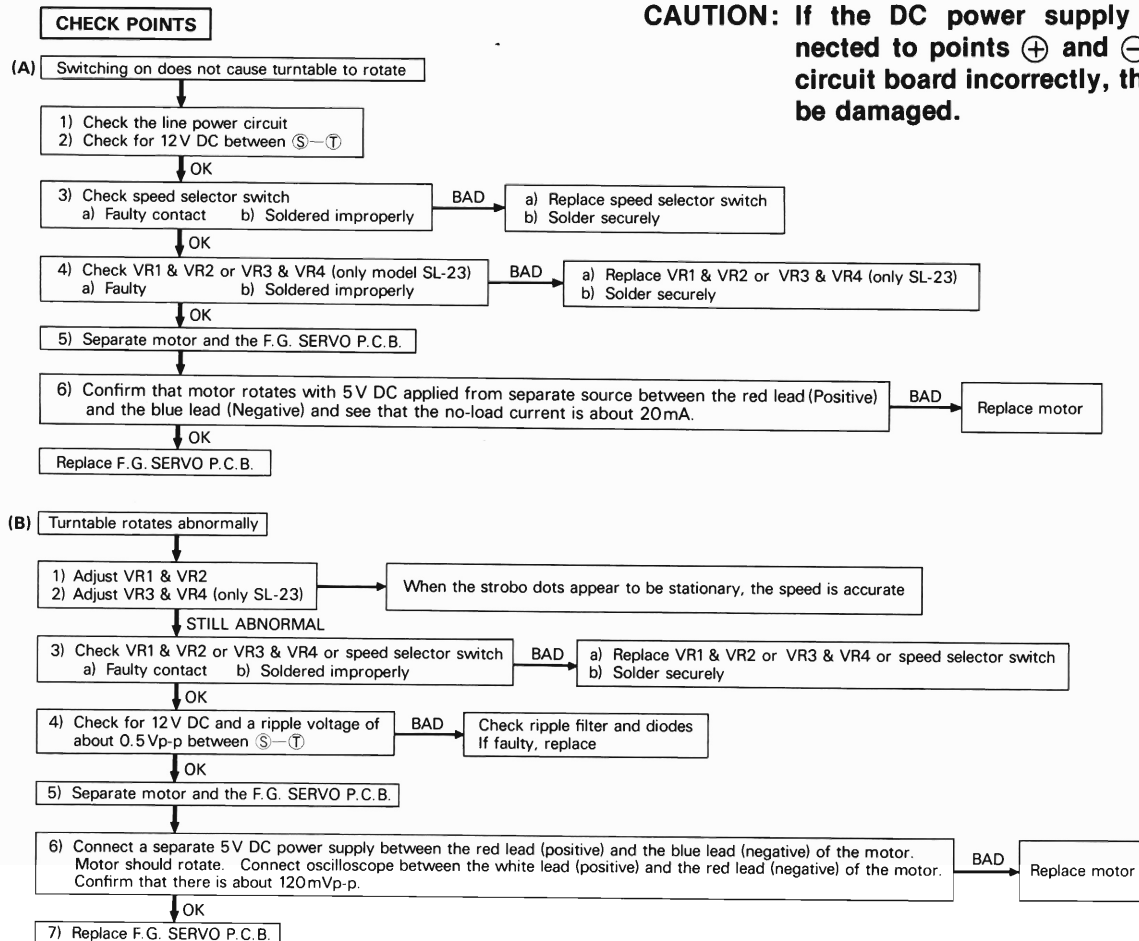

SPEED ADJUSTMENT OF SL-20, SL-23.

1. If you replace the motor or the circuit board (F.G. SERVO P.C.B.), please adjust VR1 and VR2. When the strobo dots appear to be stationary, the speed is accurate.
2. If you adjust VR1 or VR2, please turn first VR3 or VR4 to center position (only SL-23)
3. The speed will be too fast, if the strobo dots seem to be "running ahead".
In this case turn the VR1 or VR2 counterclockwise — (SL-20)
In this case turn the VR1 or VR2 clockwise — (SL-23)

SCHEMATIC DIAGRAM

