

SCHEMATIC DIAGRAM-1

NOTE:

The number which noted at the connectors on the schematic diagram as "SCHEMATIC DIAGRAM-1" or "SCHEMATIC DIAGRAM-2" indicates the schematic diagram serial number located on the left corner in the schematic diagram.

OPTICAL PICKUP

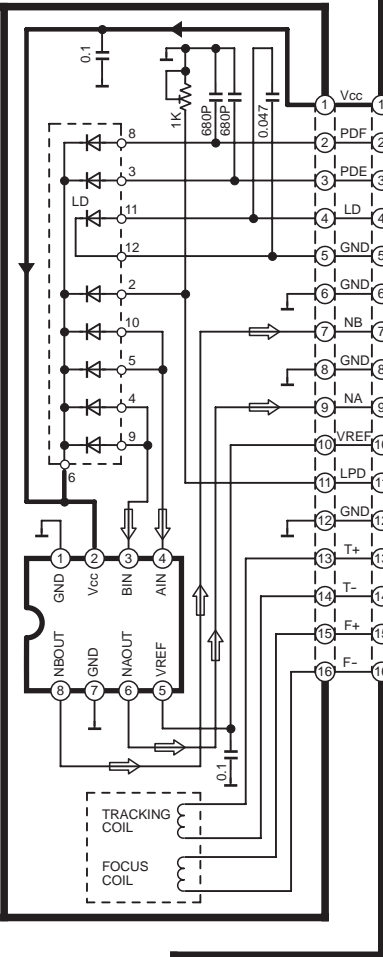

A CD SERVO CIRCUIT

→ : POSITIVE VOLTAGE LINE ⇨ : CD SIGNAL LINE

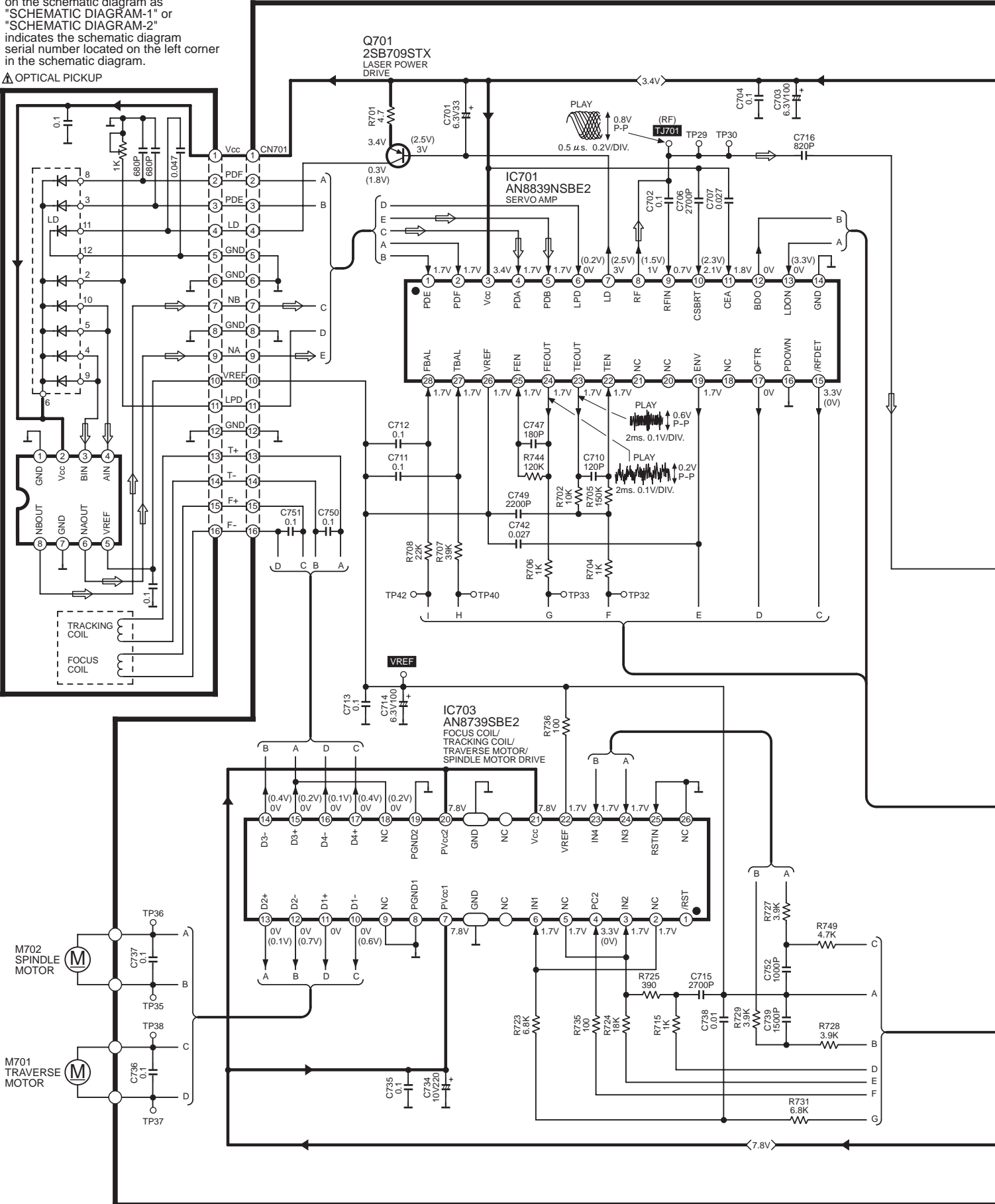

SCHEMATIC DIAGRAM-2

➔ : POSITIVE VOLTAGE LINE ⇨ : CD SIGNAL LINE

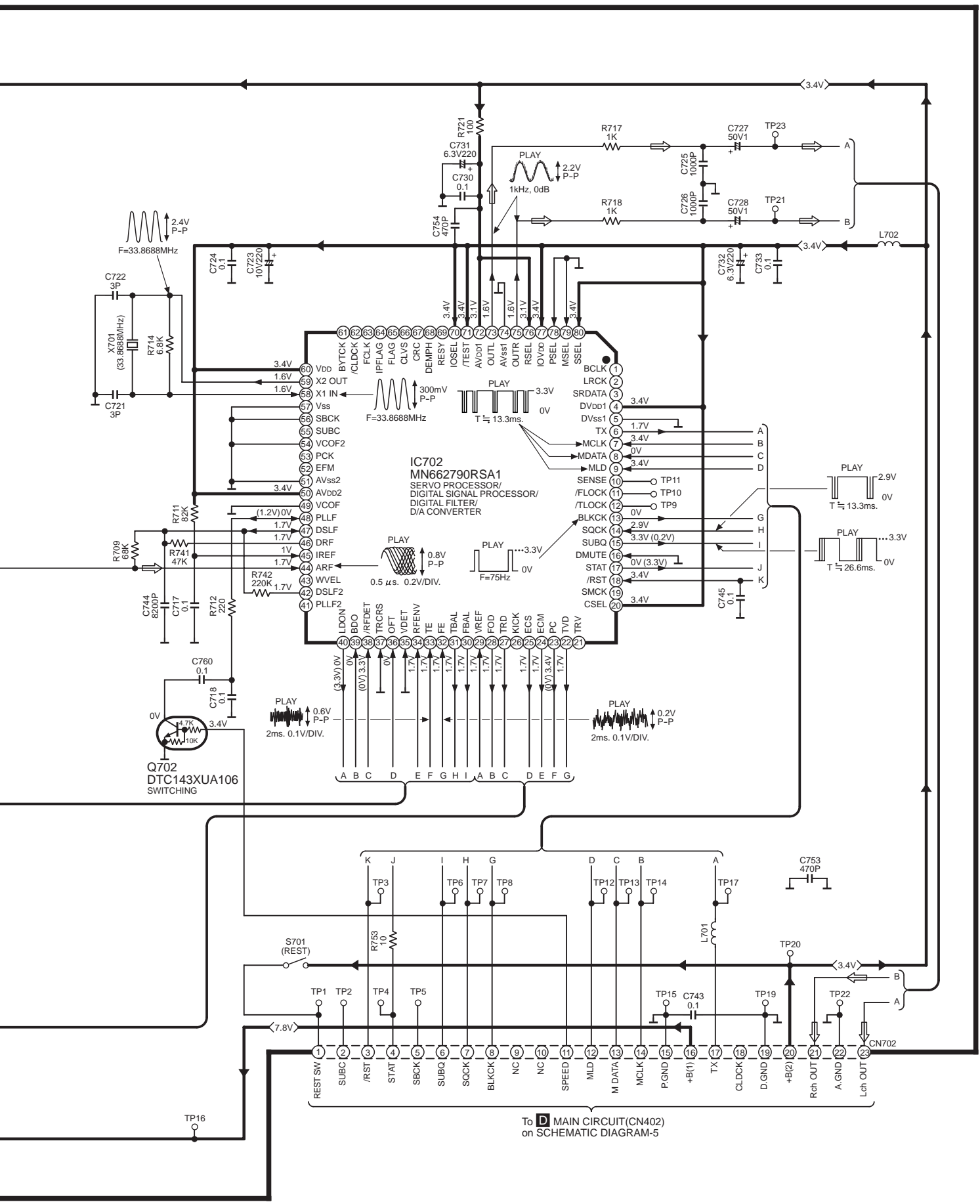

SCHEMATIC DIAGRAM-3

→ : POSITIVE VOLTAGE LINE

B LOADING MOTOR CIRCUIT

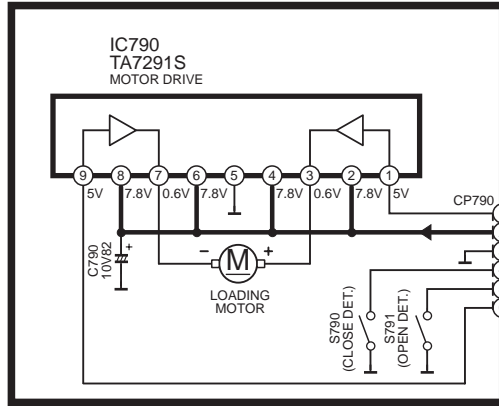

C OPERATION CIRCUIT

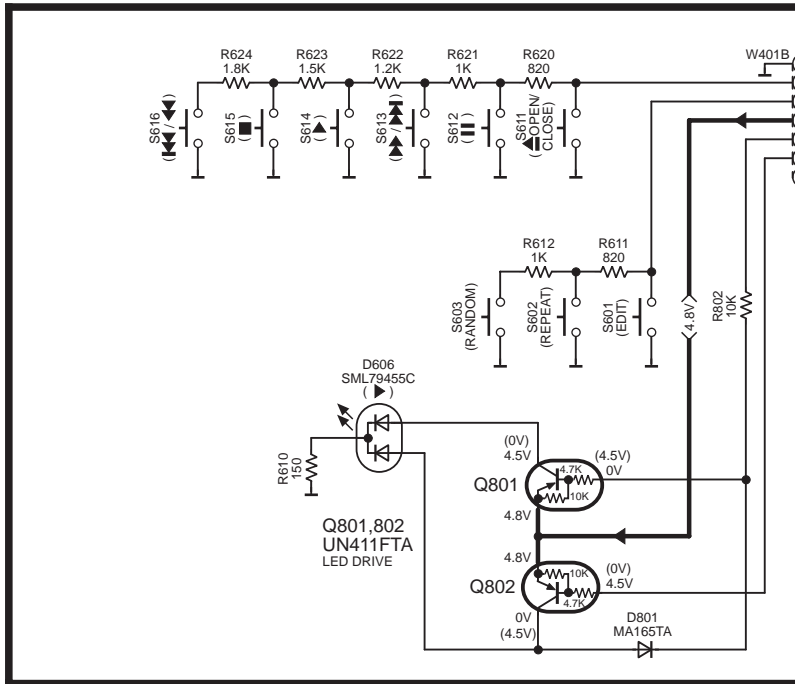

D MAIN CIRCUIT

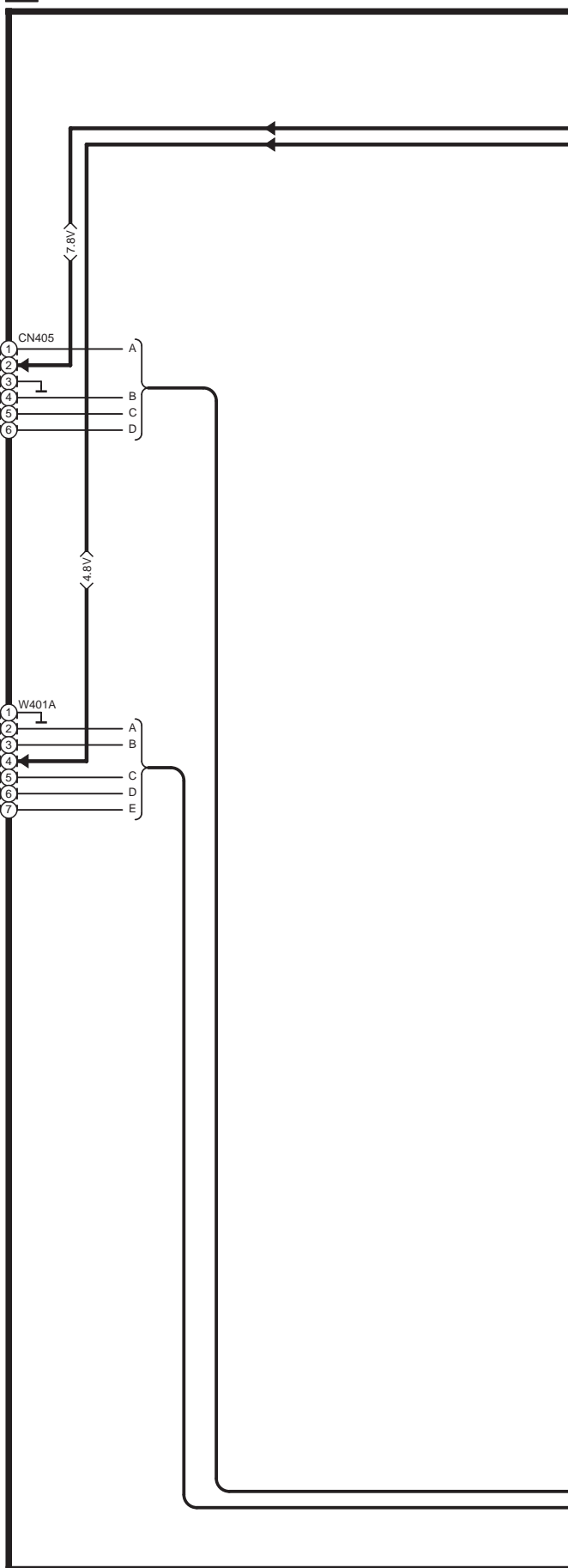

SCHEMATIC DIAGRAM-4

→ : POSITIVE VOLTAGE LINE

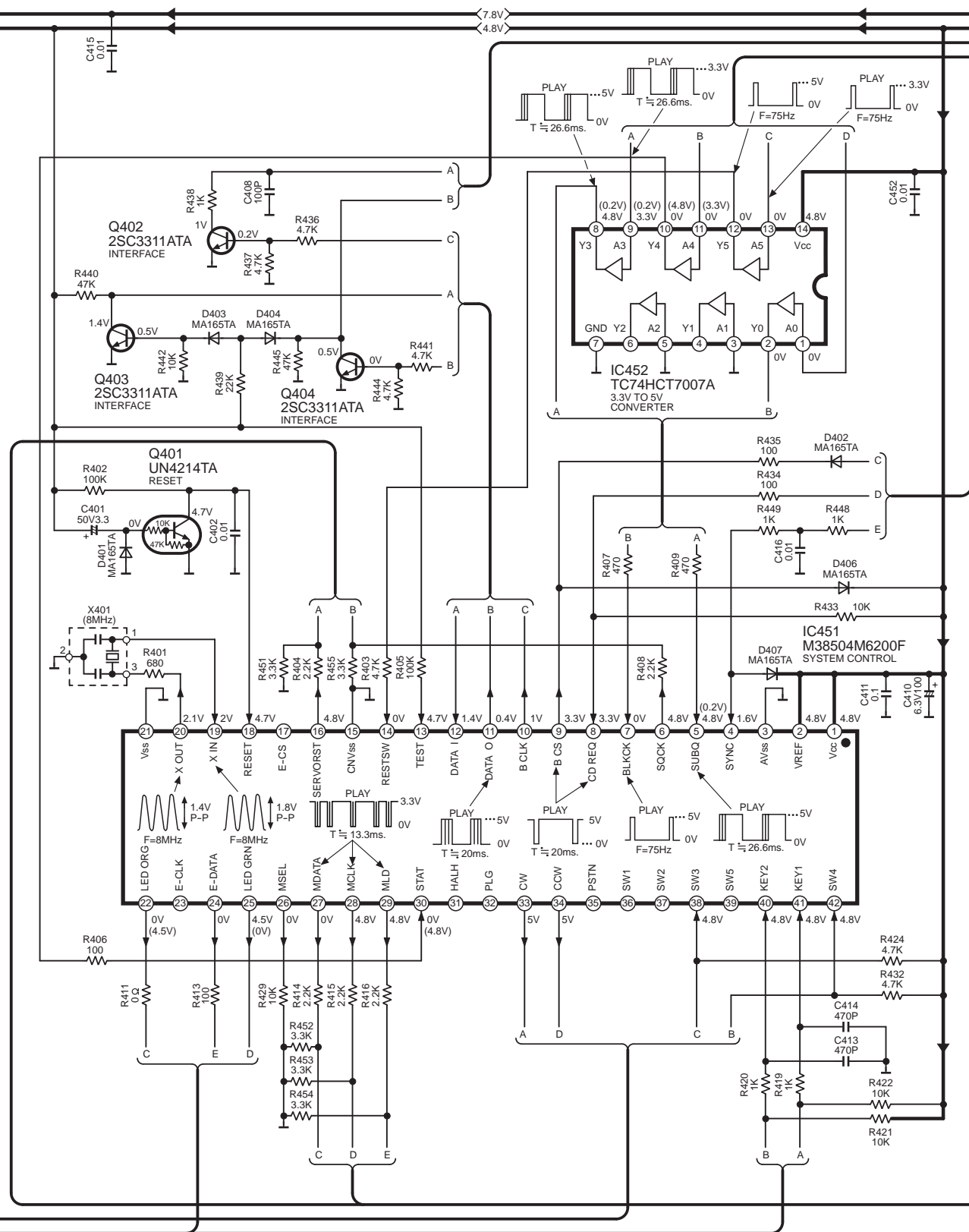

SCHEMATIC DIAGRAM-5

D MAIN CIRCUIT

➔ : POSITIVE VOLTAGE LINE ⇨ : CD SIGNAL LINE

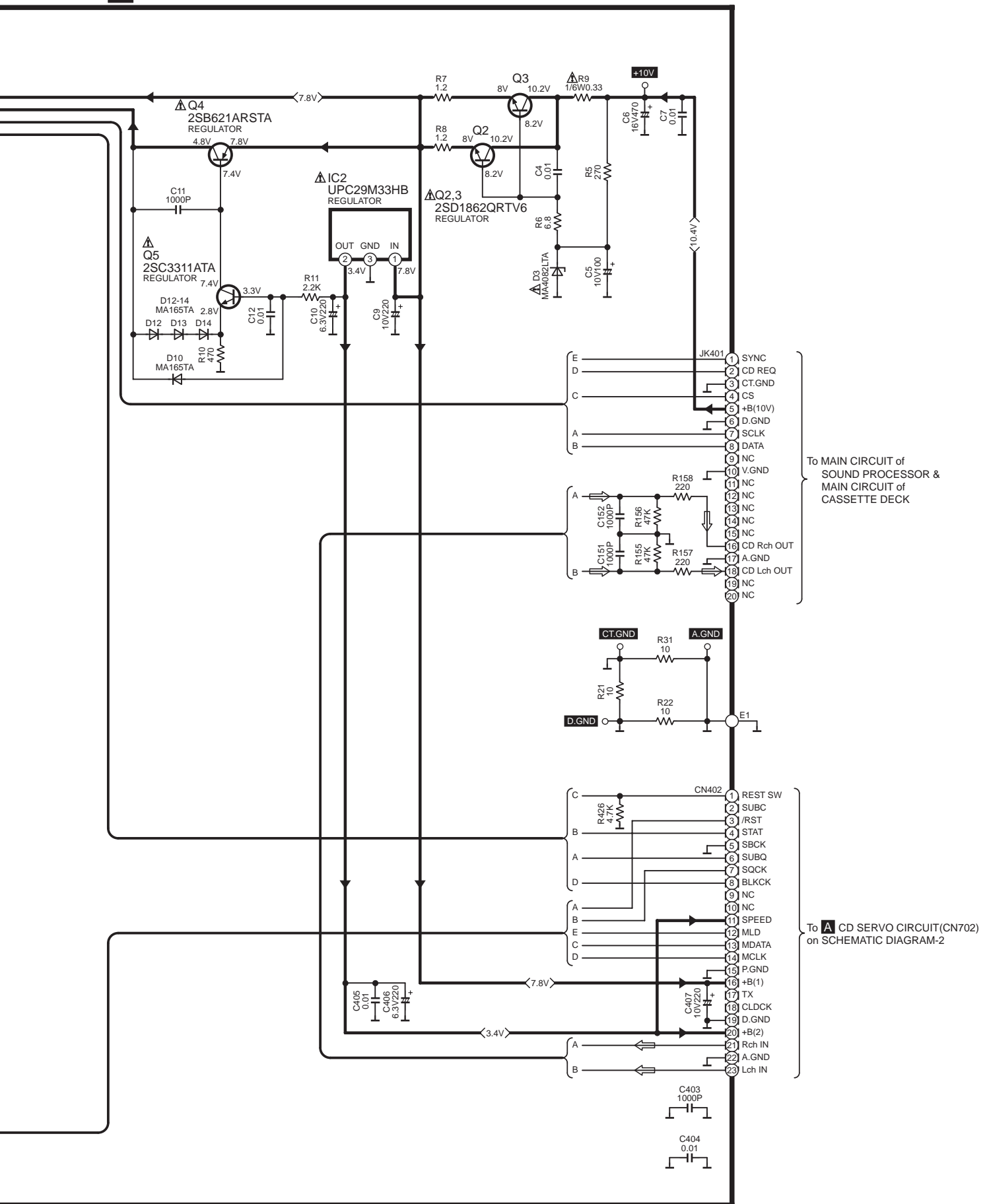

To MAIN CIRCUIT of SOUND PROCESSOR & MAIN CIRCUIT of CASSETTE DECK

To A CD SERVO CIRCUIT(CN702) on SCHEMATIC DIAGRAM-2