

Service Manual

Compact Disc Changer

SL-PD469
SL-PD665
SL-PD687
SL-PD787
SL-PD887
SL-PD987

Supplement 2



MASH*
multi-stage noise shaping



Please file and use this Service Manual together with the Service Manual for Model No. SL-PD469 Order No. AD9502038A1 (P)
 Model No. SL-PD665 Order No. AD9501011C1 (PP)
 Model No. SL-PD687 Order No. AD9501003C1 (P,PC)
 Model No. SL-PD787 Order No. AD9501009C1 (P,PC)
 Model No. SL-PD887 Order No. AD9501010C1 (P,PC)
 Model No. SL-PD987 Order No. AD9501004C1 (PP)

Colour
(K) ... Black Type

Note : This Supplement Service Manual is intended to provide additional information or correction to the existing service manual for model No. SL-PD469, SL-PD665, SL-PD687, SL-PD787, SL-PD887, SL-PD987.
 Be sure to update your Service Manual for future reference.

Area

Suffix for Model No.	Area	Colour
(P)	U.S.A.	(K)
(PC)	Canada	
(PP)	U.S.A. and Canada	

*MASH is a trademark of NTT.

CD SECTION : RAE0152Z-M TRAVERSE DECK SERIES

⚠ WARNING

This service information is designed for experienced repair technicians only and is not designed for use by the general public. It does not contain warnings or cautions to advise non-technical individuals of potential dangers in attempting to service a product. Products powered by electricity should be serviced or repaired only by experienced professional technicians. Any attempt to service or repair the product or products dealt with in this service information by anyone else could result in serious injury or death.

Schematic Diagram

A CD SERVO CIRCUIT

OPTICAL PICKUP CIRCUIT

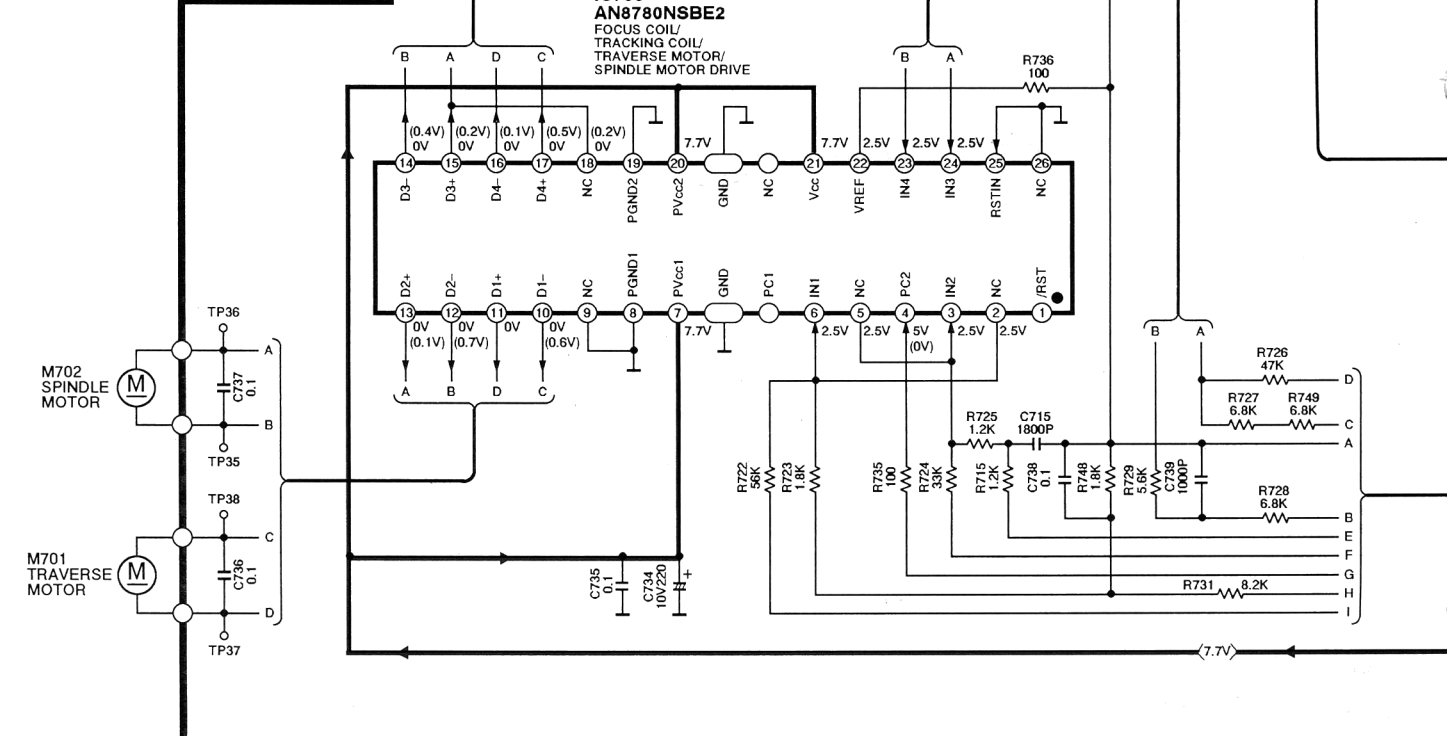
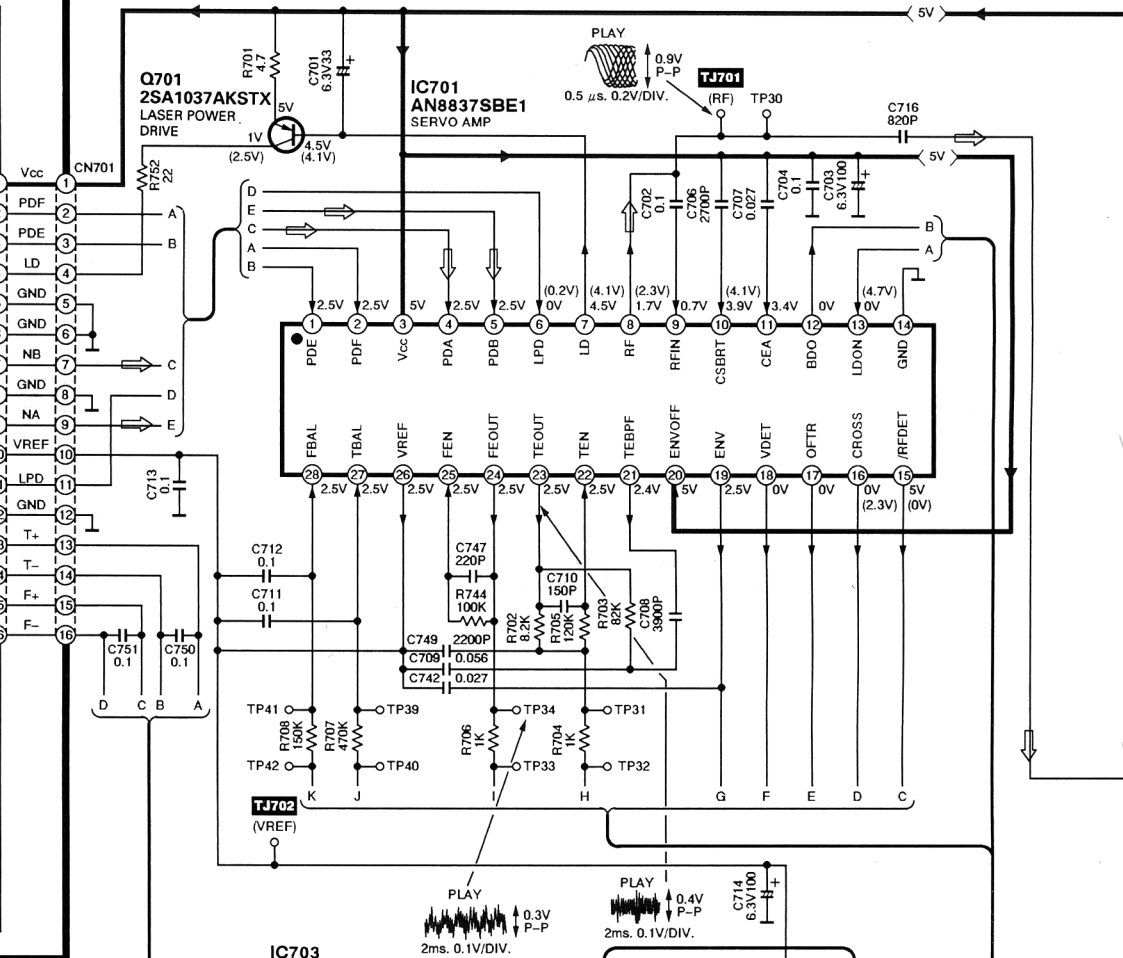
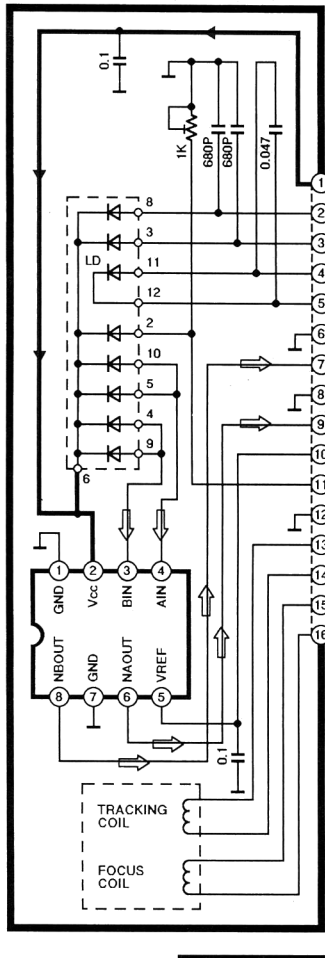

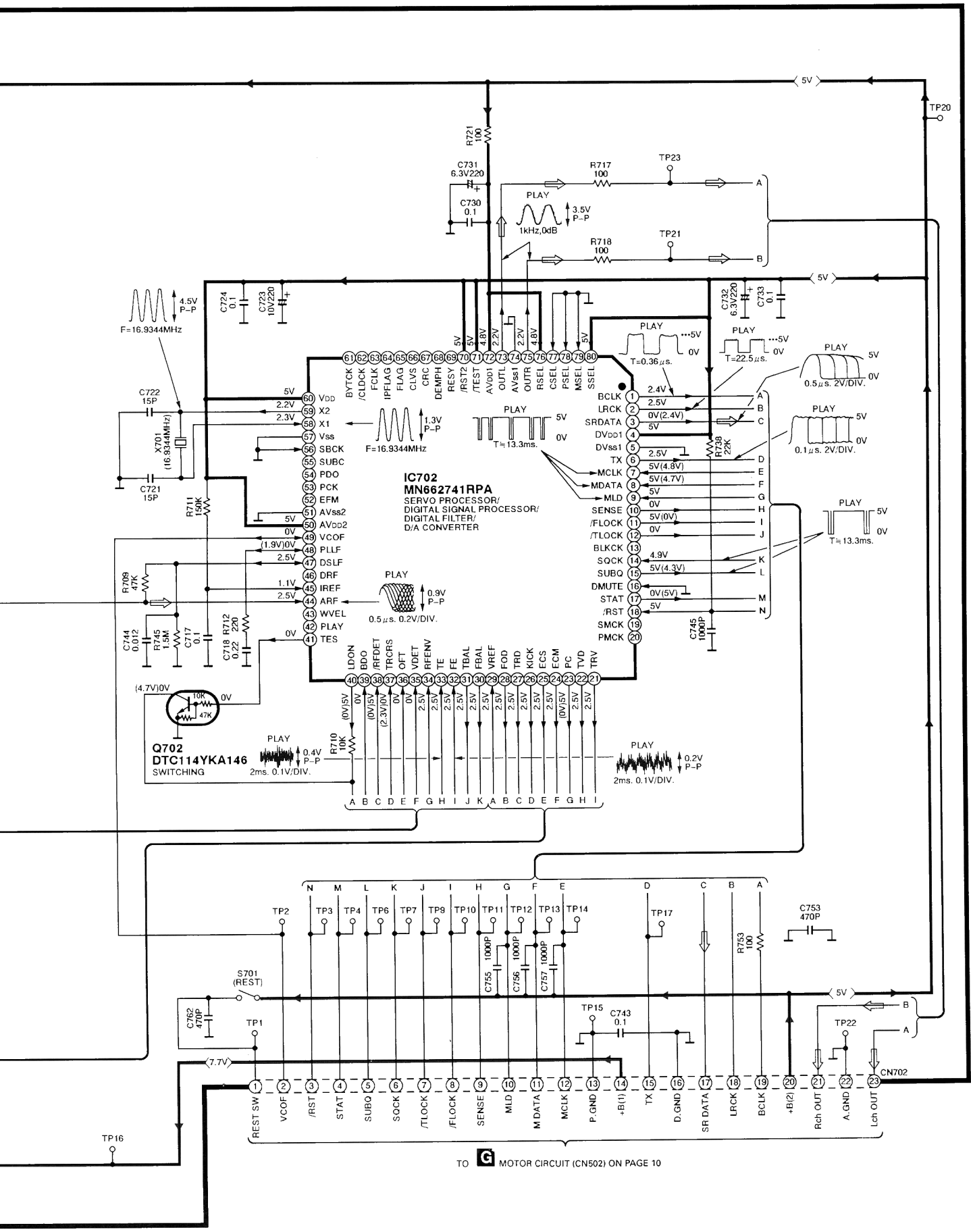

TO MOTOR CIRCUIT (CN502) ON PAGE 10

■ Printed Circuit Board (NEW)

■ A SERVO P.C.B. (REPX0144C)

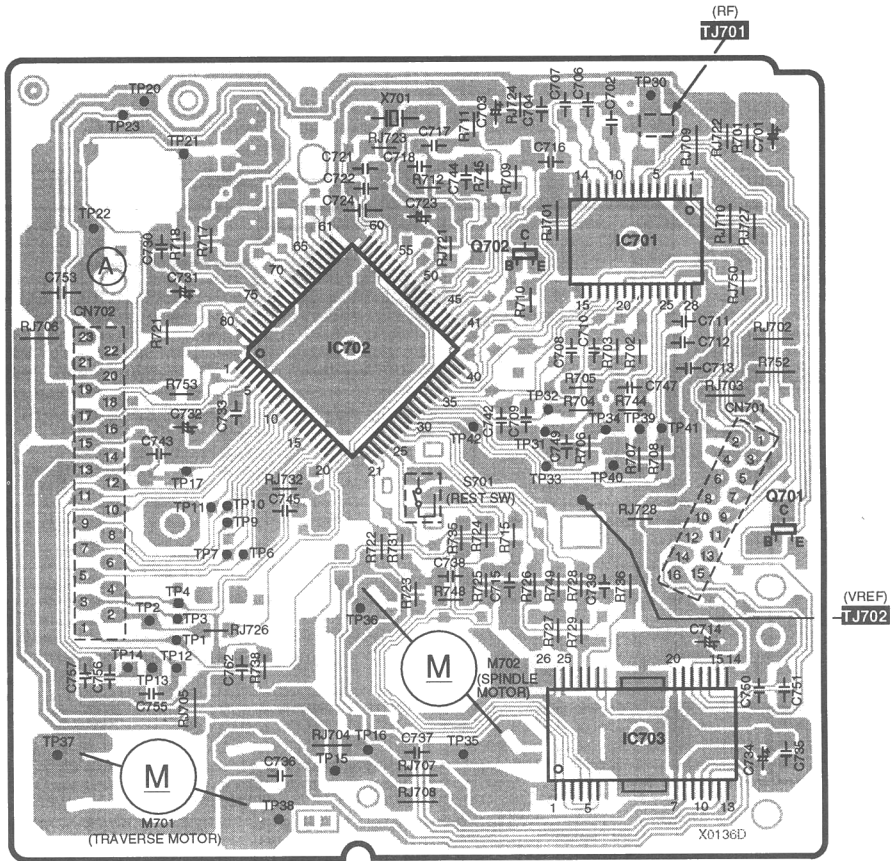

CD Replacement Parts List

Notes: New and Original are not compatible. Use proper parts as required.
 [M] Indicates in the Remarks columns indicates parts supplied by MESA.

RefNo.	PartNo.	PartName & Description	Remarks	RefNo.	PartNo.	PartName & Description	Remarks	RefNo.	PartNo.	PartName & Description	Remarks
		INTEGRATED CIRCUITS		RJ709	ERJ8GEY0R00A	CHIP JUMPER					
				RJ709	ERJ8GEY0R00A	CHIP JUMPER					
IC701	AN8837SBE1	IC, HEAD AMP		RJ710	ERJ8GEY0R00A	CHIP JUMPER					
IC702	MN662741RPA	IC, DIGITAL LSI		RJ710	ERJ8GEY0R00A	CHIP JUMPER					
IC703	AN8780NSBE2	IC, 4 CH DRIVE		RJ721	ERJ6GEY0R00A	CHIP JUMPER					
				RJ721	ERJ6GEY0R00A	CHIP JUMPER					
		TRANSISTORS		RJ722	ERJ6GEY0R00A	CHIP JUMPER					
				RJ722	ERJ6GEY0R00A	CHIP JUMPER					
Q701	2SA1037AKSTX	TRANSISTOR		RJ723	ERJ6GEY0R00A	CHIP JUMPER					
Q702	DTC114YKA146	TRANSISTOR		RJ723	ERJ6GEY0R00A	CHIP JUMPER					
				RJ724	ERJ6GEY0R00A	CHIP JUMPER					
		SWITCHES		RJ724	ERJ6GEY0R00A	CHIP JUMPER					
				RJ726	ERJ6GEY0R00A	CHIP JUMPER					
S701	RSH1A043-U	REST SWITCH		RJ726	ERJ6GEY0R00A	CHIP JUMPER					
				RJ727	ERJ6GEY0R00A	CHIP JUMPER					
		CONNECTORS		RJ727	ERJ6GEY0R00A	CHIP JUMPER					
				RJ728	ERJ6GEY0R00A	CHIP JUMPER					
CN701	RJS2A6016	16 PIN FFC CONNECTOR		RJ728	ERJ6GEY0R00A	CHIP JUMPER					
CN702	RJS1A6723-1Q	23 PIN FFC CONNCECTOR		RJ732	ERJ6GEY0R00A	CHIP JUMPER					
				RJ732	ERJ6GEY0R00A	CHIP JUMPER					
		OSCILLATORS		RJ750	ERJ6GEY0R00A	CHIP JUMPER					
				RJ750	ERJ6GEY0R00A	CHIP JUMPER					
X701	RSXZ16M9M01T	CERAMIC OSC									
						TEST JUMPER					
		CHIP JUMPERS									
				TJ701	EYF8CU	TEST JUMPER					
RJ701	ERJ6GEY0R00A	CHIP JUMPER									
RJ701	ERJ6GEY0R00A	CHIP JUMPER				MECHANISMS					
RJ702	ERJ8GEY0R00A	CHIP JUMPER									
RJ702	ERJ8GEY0R00A	CHIP JUMPER		116	RAE0152Z-M	TRV					
RJ703	ERJ8GEY0R00A	CHIP JUMPER		116-1	SHGD113-1	FLOATING CUSHION					
RJ703	ERJ8GEY0R00A	CHIP JUMPER		116-2	SNSD38	SCREW					
RJ704	ERJ8GEY0R00A	CHIP JUMPER		117	RME0109	FLOATING SPRING B					
RJ704	ERJ8GEY0R00A	CHIP JUMPER		118	RME0142	FLOATING SPRING A					
RJ705	ERJ8GEY0R00A	CHIP JUMPER		119	RMR0698-K	TRY CHASSIS					
RJ705	ERJ8GEY0R00A	CHIP JUMPER		120	RMS0123-1	FIXED PIN B					
RJ706	ERJ8GEY0R00A	CHIP JUMPER		121	RMS0350	FIXED PIN A					
RJ706	ERJ8GEY0R00A	CHIP JUMPER		124	XTN2+6G	PCB SCREW					
RJ707	ERJ8GEY0R00A	CHIP JUMPER									
RJ707	ERJ8GEY0R00A	CHIP JUMPER									
RJ708	ERJ8GEY0R00A	CHIP JUMPER									
RJ708	ERJ8GEY0R00A	CHIP JUMPER									

■ Resistors & Capacitors (Servo P.C.B.)

Notes : * Capacitor values are in microfarad (μF) unless specified otherwise, P=Pico-farads (pF) F=Farads (F)
 * Resistors values are in ohms, unless specified otherwise, 1k=1,000(OHM), 1M=1,000k(OHM)

RefNo.	PartNo.	Values&Remarks	RefNo.	PartNo.	Values&Remarks	RefNo.	PartNo.	Values&Remarks
		RESISTORS			CAPACITORS	C756	ECUZ1H102KBN	1000P 50V
						C757	ECUZ1H102KBN	1000P 50V
R701	ERJ6GEYJ4R7A	4.7 1/10W	C701	ECEA0JKA330I	33 6.3V	C762	ECUZ1H471KBN	470P 50V
R702	ERJ6GEYJ822A	8.2K 1/10W	C702	ECUZ1E104MBN	0.1 25V			
R703	ERJ6GEYJ823A	82K 1/10W	C703	ECEA0JKA101I	100 6.3V			
R704	ERJ6GEYJ102A	1K 1/10W	C704	ECUZ1E104MBN	0.1 25V			
R705	ERJ6GEYJ124A	120K 1/10W	C706	ECUZ1H272KBN	2700P 50V			
R706	ERJ6GEYJ102A	1K 1/10W	C707	ECUZ1E273KBN	0.027 25V			
R707	ERJ6GEYJ474A	470K 1/10W	C708	ECUZ1H392KBN	3900P 50V			
R708	ERJ6GEYJ154A	150K 1/10W	C709	ECUZ1E563KBN	0.056 25V			
R709	ERJ6GEYJ473A	47K 1/10W	C710	ECUV1H151KCN	150P 50V			
R710	ERJ6GEYJ103A	10K 1/10W	C711	ECUZ1E104ZFN	0.1 25V			
R711	ERJ6GEYJ154A	150K 1/10W	C712	ECUZ1E104ZFN	0.1 25V			
R712	ERJ6GEYJ221A	220 1/10W	C713	ECUZ1E104MBN	0.1 25V			
R715	ERJ6GEYJ122A	1.2K 1/10W	C714	ECEA0JKA101I	100 6.3V			
R717	ERJ6GEYJ101A	100 1/10W	C715	ECUZ1H182KBN	1800P 50V			
R718	ERJ6GEYJ101A	100 1/10W	C716	ECUZ1H821KBN	820P 50V			
R721	ERJ6GEYJ101A	100 1/10W	C717	ECUZ1E104ZFN	0.1 25V			
R722	ERJ6GEYJ563A	56K 1/10W	C718	ECUZ1C224KBN	0.22 16V			
R723	ERJ6GEYJ182A	1.8K 1/10W	C721	ECUZ1H150JCN	15P 50V			
R724	ERJ6GEYJ333A	33K 1/10W	C722	ECUZ1H150JCN	15P 50V			
R725	ERJ6GEYJ122A	1.2K 1/10W	C723	ECEA1AKA221I	220 10V			
R726	ERJ6GEYJ473A	47K 1/10W	C724	ECUZ1E104MBN	0.1 25V			
R727	ERJ6GEYJ682A	6.8K 1/10W	C730	ECUZ1E104ZFN	0.1 25V			
R728	ERJ6GEYJ682A	6.8K 1/10W	C731	ECEA0JKA221I	220 6.3V			
R729	ERJ6GEYJ562A	5.6K 1/10W	C732	ECEA0JKA221I	220 6.3V			
R731	ERJ6GEYJ822A	8.2K 1/10W	C733	ECUZ1E104MBN	0.1 25V			
R735	ERJ6GEYJ101A	100 1/10W	C734	ECEA1AKA221I	220 10V			
R736	ERJ6GEYJ101A	100 1/10W	C735	ECUZ1E104ZFN	0.1 25V			
R738	ERJ6GEYJ223A	22K 1/10W	C736	ECUZ1E104ZFN	0.1 25V			
R744	ERJ6GEYJ104A	100K 1/10W	C737	ECUZ1E104ZFN	0.1 25V			
R745	ERJ6GEYJ155A	1.5M 1/10W	C738	ECUZ1E104MBN	0.1 25V			
R748	ERJ6GEYJ182A	1.8K 1/10W	C739	ECUZ1H102KBN	1000P 50V			
R749	ERJ6GEYJ682A	6.8K 1/10W	C742	ECUZ1E273KBN	0.027 25V			
R752	ERJ8GEYJ220A	22 1/8W	C743	ECUZ1E104ZFN	0.1 25V			
R753	ERJ6GEYJ102A	1K 1/10W	C744	ECUZ1E123KBN	0.012 25V			
			C745	ECUZ1H102KBN	1000P 50V			
			C747	ECUV1H221KBN	220P 50V			
			C749	ECUZ1H222KBN	2200P 50V			
			C750	ECUZ1E104MBN	0.1 25V			
			C751	ECUZ1E104MBN	0.1 25V			
			C753	ECUZ1H471KBN	470P 50V			
			C755	ECUZ1H102KBN	1000P 50V			

■ CD Loading Unit Parts Location

