

# Service Manual

COMPACT  
disc  
DIGITAL AUDIO

DIGITAL

MASH<sup>®</sup>  
multi-stage noise shaping

Compact Disc Changer

## SL-PD667

Colour

(K) ... Black Type



Area

Suffix for Model No.	Area	Colour
(E)	Europe.	(K)
(EB)	Great Britain.	
(EG)	Germany and Italy.	
(GC)	Asia, Latin America, Middle Near east and Africa.	
(GN)	Oceania.	

## RAE0113Z MECHANISM SERIES

### SPECIFICATIONS

#### AUDIO

No. of channels	2 (left and right, stereo)
Frequency response	2-20,000 Hz. $\pm 1$ dB
Output voltage	2 V (at 0 dB)
Dynamic range	92 dB
S/N	100 dB
Total harmonic distortion	0.007 % (1 kHz, 0 dB)
Wow and flutter	Below measurable limit
DA converter	MASH (1 bit)
Output impedance	Approx. 1 k $\Omega$
Load impedance	More than 10 k $\Omega$

#### PICKUP

Wavelength	780 nm
------------	--------

### CONTENTS

	Page
PRECAUTION OF LASER DIODE.....	2
ACCESSORIES .....	3
CONNECTIONS .....	3
CAUTION FOR AC MAINS LEAD .....	4
FRONT PANEL CONTROLS.....	5
CAUTIONS CONCERNING THE MOVING OF THIS UNIT.....	5
BASIC OPERATIONS.....	6, 7
HANDLING PRECAUTIONS FOR TRAVERSE DECK.....	8
DISASSEMBLY INSTRUCTIONS.....	9~17
HOW TO CHECK THE MAIN AND SERVO P.C.B. ....	18, 19
OPERATING THE UNIT WITHOUT THE FRONT PANEL ASS'Y .....	19
REPLACEMENT OF THE FOOT .....	20
DISPLAY FUNCTION OF AUTOMATICALLY-ADJUSTED RESULTS (SELF-CHECK FUNCTION).....	20, 21

- ※ • Technics (or Panasonic) developed the world's first MASH type DAC and ADC. MASH technology was invented by NTT (LSI Labs).  
• MASH is a trademark of NTT.

#### GENERAL

##### Power consumption

For (E, EB, EG, GN) areas.:	12 W
For (GC) area.:	14 W

##### Power supply

For (E, EB, EG, GN) areas.:	AC 50/60 Hz, 230-240 V
For (GC) area.:	AC 50/60 Hz, 110 V/127 V/220 V/240 V

##### Dimensions (W x H x D)

430 x 125 x 370 mm (16-15/16" x 4-15/16" x 14-9/16")
---

##### Weight

4.6 kg (10.1 lb.)
-------------------

##### Note:

Design and specifications are subject to change without notice.  
Weight and dimensions are approximate.

	Page
DIGITAL SERVO SYSTEM .....	22
TROUBLESHOOTING GUIDE.....	23, 24
MEASUREMENTS AND ADJUSTMENTS .....	25, 26
TERMINAL FUNCTION OF IC'S.....	27~30
BLOCK DIAGRAM.....	31~33
SCHEMATIC DIAGRAM .....	34~39
PRINTED CIRCUIT BOARDS .....	40~42
WIRING CONNECTION DIAGRAM.....	43
REPLACEMENT PARTS LIST.....	44
CABINET PARTS LOCATION .....	45, 46
LOADING MECHANISM PARTS.....	47
REPLACEMENT PARTS LIST .....	48, 49
RESISTORS AND CAPACITORS .....	50, 51
PACKAGING .....	51

# Technics

## ■ PRECAUTION OF LASER DIODE

**CAUTION:** This product utilizes a laser diode with the unit turned "on", invisible laser radiation is emitted from the pickup lens.  
Wave length: 780nm  
Maximum output radiation power from pickup: 100µW/VDE

Laser radiation from the pickup lens is safety level, but be sure the followings:

1. Do not disassemble the optical pickup unit, since radiation from exposed laser diode is dangerous.
2. Do not adjust the variable resistor on the pickup unit. It was already adjusted.
3. Do not look at the focus lens using optical instruments.
4. Recommend not to look at pickup lens for a long time.

**ACHTUNG:** Dieses Produkt enthält eine Laserdiode. Im eingeschalteten Zustand wird unsichtbare Laserstrahlung von der Lasereinheit abgestrahlt.

Wellenlänge: 780nm

Maximale Strahlungsleistung der Lasereinheit: 100µW/VDE

Die Strahlung an der Lasereinheit ist ungefährlich, wenn folgende Punkte beachtet werden:

1. Die Lasereinheit nicht zerlegen, da die Strahlung an der freigelegten Laserdiode gefährlich ist.
2. Den werkseitig justierten Einstellregler der Lasereinheit nicht verstellen.
3. Nicht mit optischen Instrumenten in die Fokussierlines blicken.
4. Nicht über längere Zeit in die Fokussierlinse blicken.

**ADVARSEL:** I dette a apparat anvendes laser.

### • Use of caution labels

Note: ○ Mark is used, × Mark is not used.

Areas	SQWD7	RQLS0021	RQLS0078
(E)	○	○	○
(EB)	○	○	×
(EG)	○	○	×
(GC)	○	○	×
(GN)	○	○	×

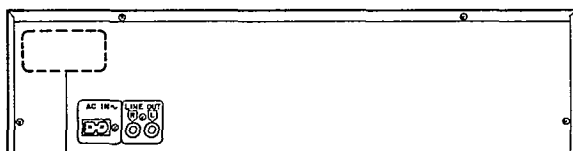

SQWD7

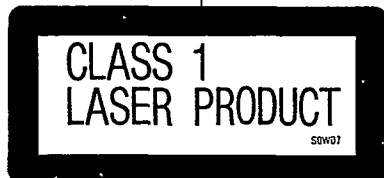

LUOKAN 1 LASERLAITE  
KLASS 1 LASER APPARAT

RQLS0078

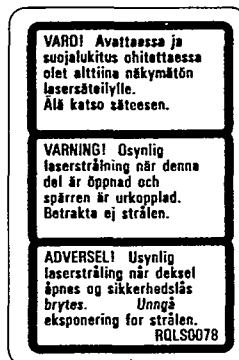

RQLS0021

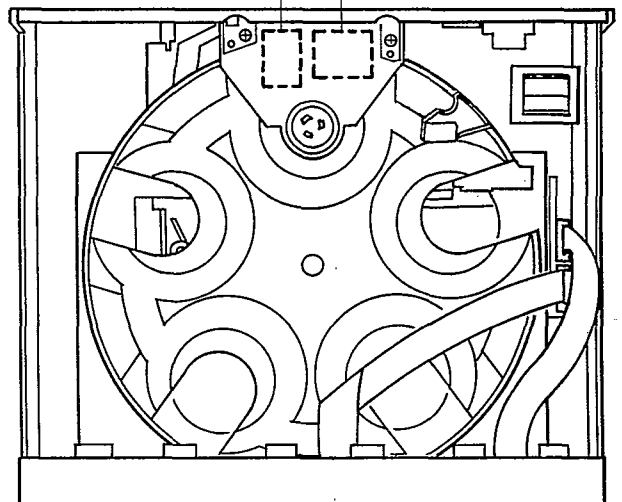
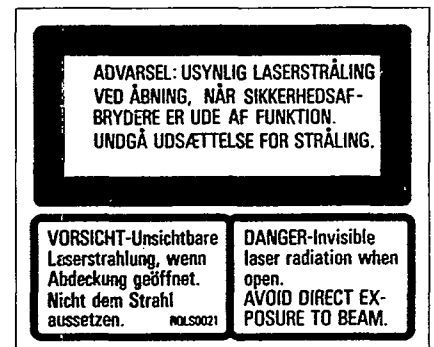

## ACCESSORIES

AC power supply cord ..... 1 pc.  
 [VJA0733 (EB)]      [RJA0036-K (GN)]      [RJA0019-2K (E, EG, GC)]

Stereo connection  
 cable ..... 1 pc.  
 [SJP2249-3]

Power plug  
 adaptor ..... 1 pc.  
 [SJP5213-1 (GC)]

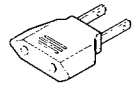
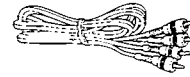
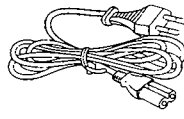
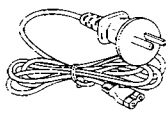
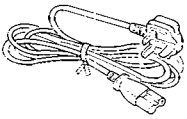





## CONNECTIONS

Before connecting the changer to your audio system, make sure that the power of the changer and all other system components is turned off.

- Although the figure below shows the AC power supply cord being connected to a household AC outlet, if the amplifier (or receiver) is equipped with an AC outlet, connect the cord to that outlet.
- The configuration of the AC outlet differs according to area.

### Stereo connection cable

White (L)    
 Red (R)  

[For (EB) area only]

**BE SURE TO READ THE CAUTION FOR AC POWER SUPPLY CORD ON PAGE 3 BEFORE THE FOLLOWING CONNECTIONS.**

[For (GC) area only]

Set the voltage selector to the voltage setting for the area in which the unit will be used.  
 [Use a minus (-) screwdriver]

**Note**

If the power supply in your area is 117 V or 120 V, set to the "127 V" position.  
 Note that this unit will be seriously damaged if this setting is not made correctly.

If the power plug will not fit your socket, use the power plug adaptor (included).

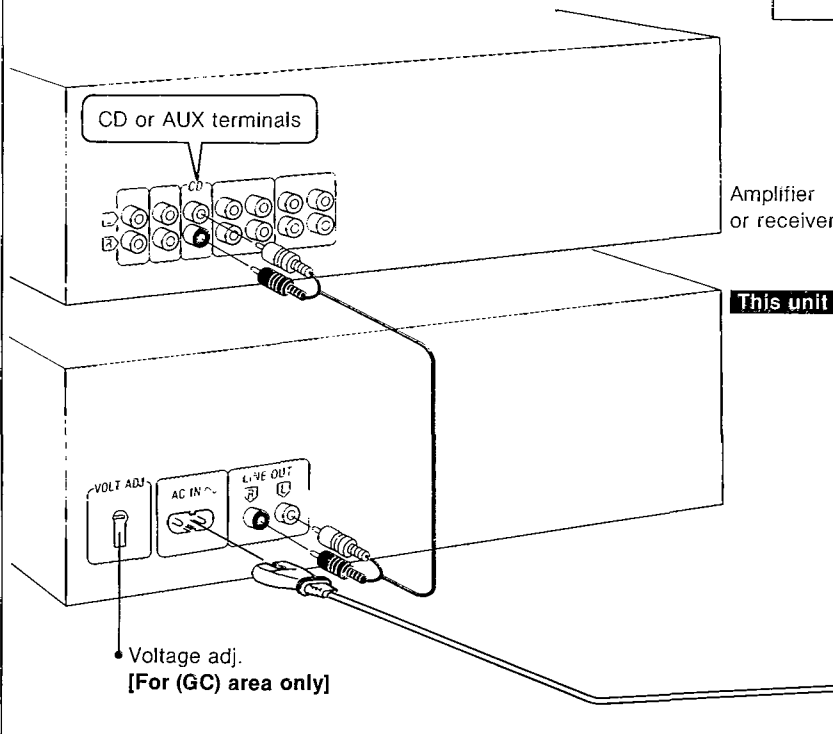
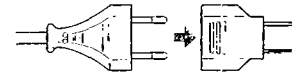

[For (E, EB, EG, GC) areas]  
**Insertion of Connector**

Even when the connector is perfectly inserted, depending on the type of inlet used, the front part of the connector may jut out as shown in the drawing.  
 However there is no problem using the unit.

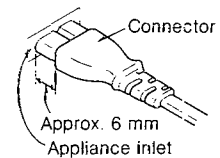

## ■ CAUTION FOR AC MAINS LEAD

### For (EB) area.

(“EB” area code model only)

For your safety, please read the following text carefully.

This appliance is supplied with a moulded three pin mains plug for your safety and convenience.

A 5-ampere fuse is fitted in this plug.

Should the fuse need to be replaced please ensure that the replacement fuse has a rating of 5-ampere and that it is approved by ASTA or BSI to BS1362.

Check for the ASTA mark  or the BSI mark  on the body of the fuse.

If the plug contains a removable fuse cover you must ensure that it is refitted when the fuse is replaced.

If you lose the fuse cover the plug must not be used until a replacement cover is obtained.

A replacement fuse cover can be purchased from your local dealer.

### CAUTION!

IF THE FITTED MOULDED PLUG IS UNSUITABLE FOR THE SOCKET OUTLET IN YOUR HOME THEN THE FUSE SHOULD BE REMOVED AND THE PLUG CUT OFF AND DISPOSED OF SAFELY.

THERE IS A DANGER OF SEVERE ELECTRICAL SHOCK IF THE CUT OFF PLUG IS INSERTED INTO ANY 13-AMPERE SOCKET.

If a new plug is to be fitted please observe the wiring code as shown below.

If in any doubt please consult a qualified electrician.

### IMPORTANT

The wires in this mains lead are coloured in accordance with the following code:

Blue: Neutral

Brown: Live

As the colours of the wires in the mains lead of this appliance may not correspond with the coloured markings identifying the terminals in your plug, proceed as follows:

The wire which is coloured BLUE must be connected to the terminal in the plug which is marked with the letter N or coloured BLACK.

The wire which is coloured BROWN must be connected to the terminal in the plug which is marked with the letter L or coloured RED.

Under no circumstances should either of these wires be connected to the earth terminal of the three pin plug, marked with the letter E or the Earth Symbol .

### Before use

Remove the connector cover as follows.

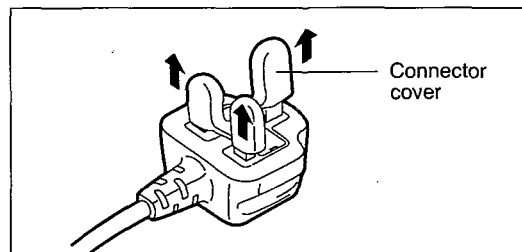

### How to replace the fuse

1. Remove the fuse cover with a screwdriver.

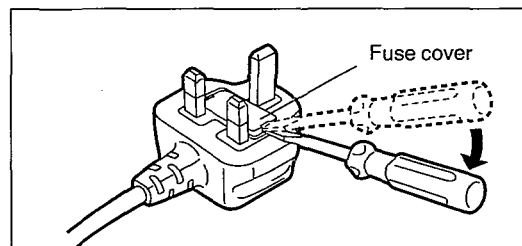

2. Replace the fuse and attach the fuse cover.

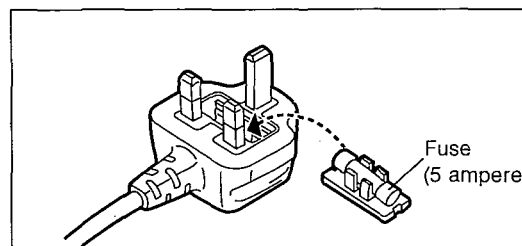

## FRONT PANEL CONTROLS

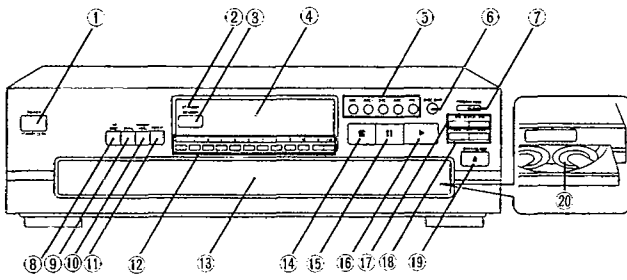

No.	Name	Ref. page
①	<b>Power "STANDBY <math>\odot</math> /ON" switch (POWER, STANDBY <math>\odot</math> /ON)</b> Press to switch the unit from on to standby mode or vice versa. In standby mode, the unit is still consuming a small amount of power.	
②	<b>"STANDBY" indicator (STANDBY)</b> When the unit is connected to the AC mains supply, this indicator lights up in standby mode and goes out when the unit is turned on.	
③	<b>Remote control signal sensor (SENSOR)</b> The word "SENSOR" does not appear on the panel, but if you have an amplifier (or receiver) with remote control transmitter which is manufactured by Technics, it is possible to operate the main unit using this remote control transmitter. (Some remote control transmitters cannot be used.)	
④	<b>Display</b>	
⑤	<b>Disc buttons (DISC 1 - 5)</b>	
⑥	<b>Disc skip button (DISC SKIP)</b>	
⑦	<b>Program mode button (PROGRAM MODE)</b>	
⑧	<b>Time mode button (TIME MODE)</b>	
⑨	<b>Spiral button (SPIRAL)</b>	
⑩	<b>Random mode button (RANDOM MODE)</b>	
⑪	<b>Repeat button (REPEAT)</b>	
⑫	<b>Numeric buttons (1 - 10, 0, &gt; 10)</b>	
⑬	<b>Loading drawer</b>	
⑭	<b>Stop button (■)</b>	
⑮	<b>Pause button (⏸)</b>	
⑯	<b>Play button (▶)</b>	
⑰	<b>Search buttons (◀◀ SEARCH ▶▶)</b>	

No.	Name	Ref. page
⑱	<b>Skip buttons (◀◀ SKIP ▶▶)</b>	
⑲	<b>Loading drawer open/close button (▲ OPEN/CLOSE)</b>	
⑳	<b>Disc trays (1 - 5)</b>	

## CAUTIONS CONCERNING THE MOVING OF THIS UNIT

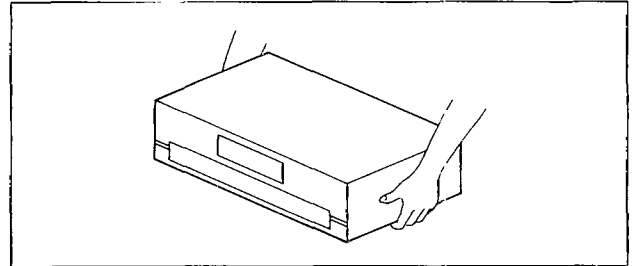

### CAUTION

Before moving the changer to another location, be sure to carry out the "Preparations for moving the unit" described below.

Failure to do so will expose the compact discs and the changer to the risk of severe damage.

### Preparations for moving the unit

All of the discs must be removed so that the trays are completely empty.

Use the following procedure.

- ① Press **POWER** to switch off the unit.
- ② Press **POWER** to switch on the unit.  
(If there is a disc in the play section, it will be returned to the disc tray at this time.)
- ③ Press **OPEN/CLOSE** to open the loading drawer.
- ④ Press **DISC SKIP** to rotate the disc trays and remove the discs from all disc trays.
- ⑤ Press **OPEN/CLOSE** to close the loading drawer.
- ⑥ Press **POWER** to switch off the unit.

If you have pressed a wrong button by mistake, return to step ①.

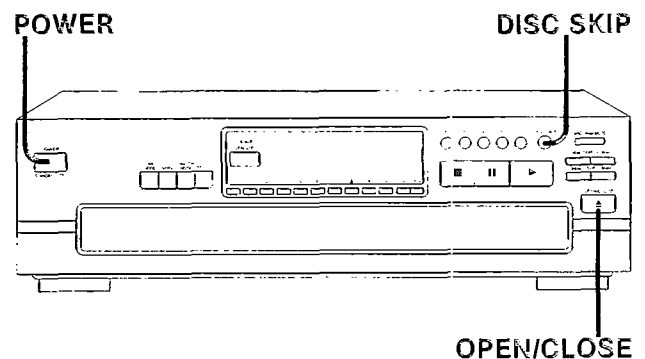

# BASIC OPERATIONS

## Sequential play

All of the discs will be played, beginning from track 1 on the selected disc.

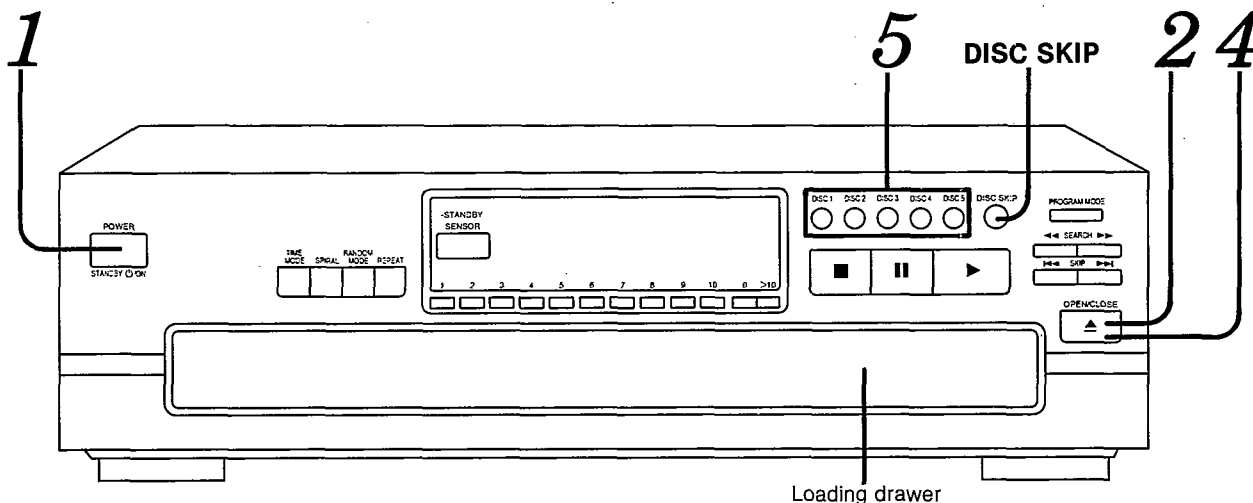

The explanation below is an example of operation in the case where all five disc trays in the changer are holding CDs.

**1/** **Press POWER.**  
 The unit will switch on.

**2/** **Press OPEN/CLOSE to open the loading drawer.**  
 Indicates that the loading drawer is open.

Numbers of the trays in which discs are loaded.

**3/** **Load the disc(s) on the disc tray(s).**  
 The discs can be loaded two at a time by pressing DISC SKIP to rotate the carousel.

Label must face upward.

**Note**  
 Do not load 3" (8 cm) and 5" (12 cm) discs on the same disc tray.

**CAUTION**  
 Do not touch the loading drawer and carousel while they are in motion, and do not attempt to rotate the carousel by hand; doing so could result in incorrect operation of the unit and/or damage to the discs.

**4/** **Press OPEN/CLOSE again to close the loading drawer.**

**Note**  
 Do not attempt to close the drawer by hand.

Current play position (The numeral illuminates with a red color.)

Disc 4 is illuminated in red.

Disc number in play: 4  
 Elapsed play time: 00:00

**5/** **Press the desired disc button (1-5).**  
 Play will begin from the selected disc. If a disc is not on the selected disc tray, the changer plays the disc at the next number.

Disc 5 is illuminated in red.

Disc number in play: 5  
 Elapsed play time: 0:01

Track number in play: 1  
 Play indicator: [arrow]

The changer plays all the tracks on all the discs in order and stops automatically when the last track on the last disc finishes playing. The first disc will then be at the playing position.

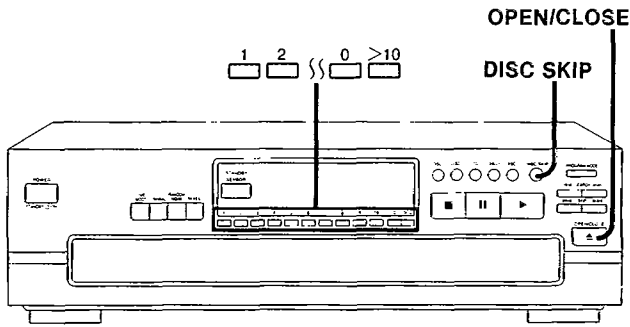

### To directly access a desired track

Press the numeric button(s) to select the track.

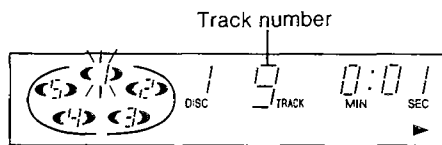

#### To select a track between 1 and 10:

Press the corresponding number on the numeric button.

**To select a two-digit track number over 10:**  
First press >10, and then press the numbers for the two digits.

**For example; number 20:**

Press >10, then 2, and then 0.

### To exchange discs during play

While playing a disc, it is possible to change the other discs without interrupting play.

① Press OPEN/CLOSE to open the loading drawer.

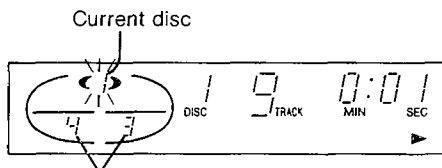

Discs which can be changed.

② Press DISC SKIP to rotate the disc trays and exchange the discs.

The carousel will move by one disc tray. Pressing again moves the carousel in the opposite direction by two disc trays.

③ Press OPEN/CLOSE to close the loading drawer.

#### Note

If you play a disc with the loading drawer open, discs other than the current disc cannot be played.

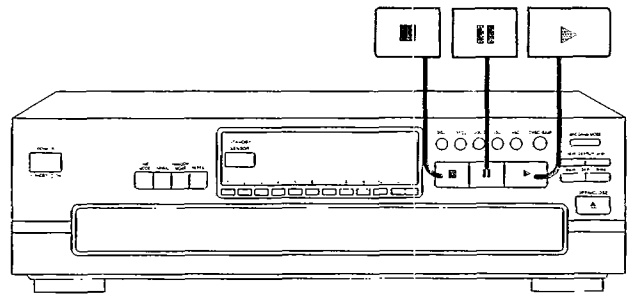

### To temporarily stop play



Press **II**.

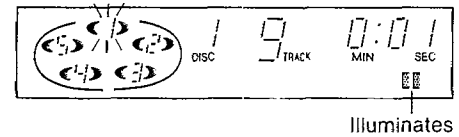

Illuminates

### To resume play

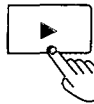

Press **▶**.

### To stop play

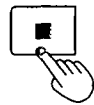

Press **■**.

The display will show the total number of tracks and the total playing time of the current disc.

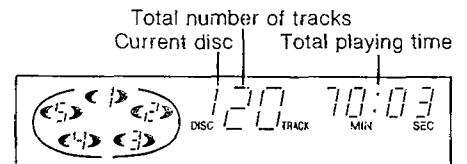

The total playing time displayed includes the silent sections between tracks. For this reason, it may be a few seconds longer than the playing time indicated on the disc.

### To resume play

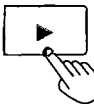

Press **▶**.

#### CAUTION

Do not move this changer with a compact disc inside the unit. If a disc comes off the disc tray, it might be scratched or the changer might become incapable of playing. (Refer to "Cautions concerning the moving of this unit" on page 5.)

## HANDLING PRECAUTIONS FOR TRAVERSE DECK

The laser diode in the traverse deck (optical pickup) may break down due to potential difference caused by static electricity of clothes or human body.

So, be careful of electrostatic breakdown during repair of the traverse deck (optical pickup).

### • Handling of traverse deck (optical pickup)

1. Do not subject the traverse deck (optical pickup) to static electricity as it is extremely sensitive to electrical shock.
2. To prevent the breakdown of the laser diode, an antistatic shorting pin is inserted into the flexible board (FPC board).  
When removing or connecting the short pin, finish the job in as short time as possible.
3. Take care not to apply excessive stress to the flexible board (FPC board).
4. Do not turn the variable resistor (laser power adjustment). It has already been adjusted.

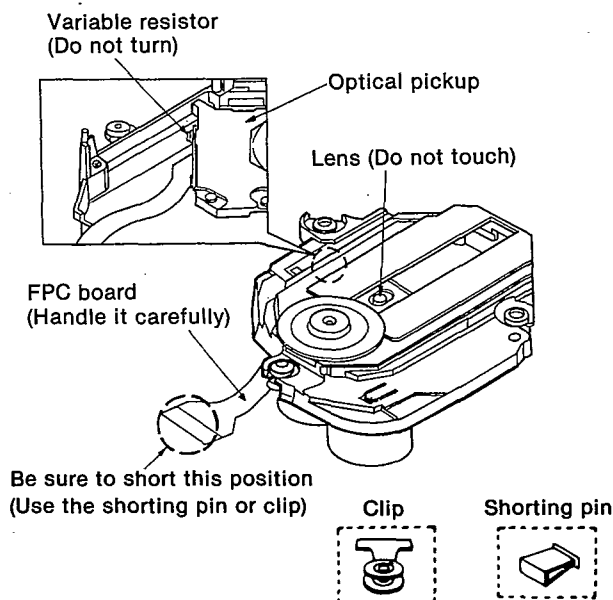

### • Grounding for electrostatic breakdown prevention

1. Human body grounding  
Use the anti-static wrist strap to discharge the static electricity from your body.
2. Work table grounding  
Put a conductive material (sheet) or steel sheet on the area where the optical pickup is placed, and ground the sheet.

#### Caution:

The static electricity of your clothes will not be grounded through the wrist strap. So, take care not to let your clothes touch the traverse deck (optical pickup).

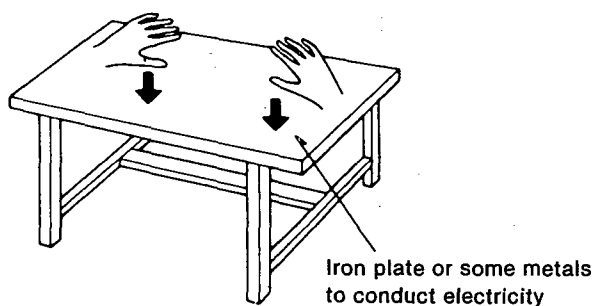
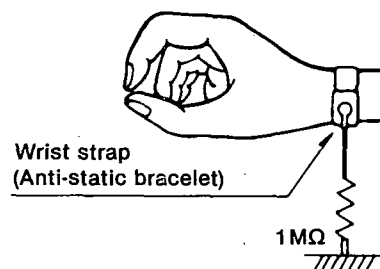



## DISASSEMBLY INSTRUCTIONS

### "ATTENTION SERVICER"

Some chassis components may have sharp edges. Be careful when disassembling and servicing.

**Warning:** This project uses a laser diode. Refer to caution statements on page 2.

**ACHTUNG:** • Die Lasereinheit nicht zerlegen.

• Die Lasereinheit darf nur gegen eine vom hersteller spezifizierte einheit ausgetauscht werden.

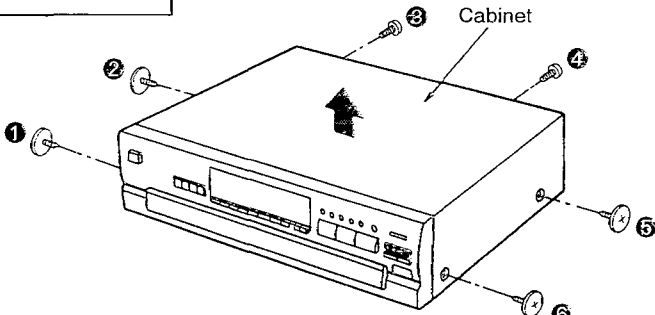
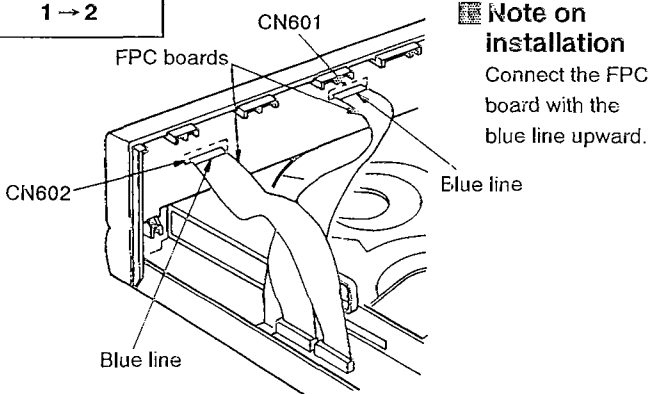
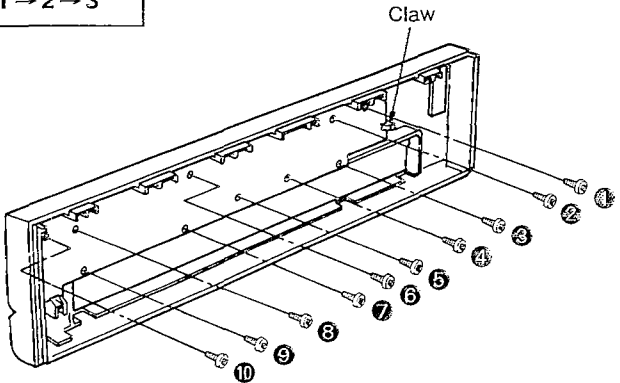
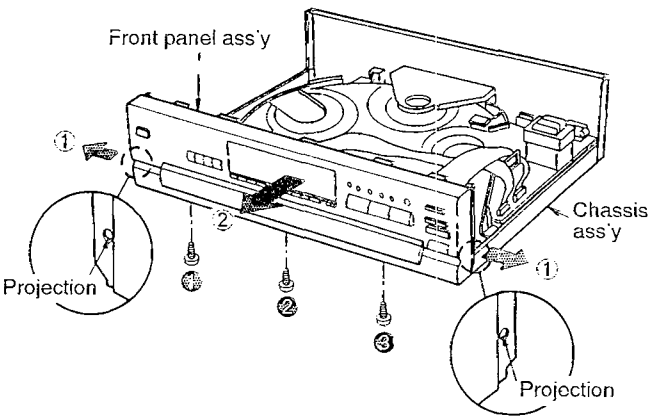
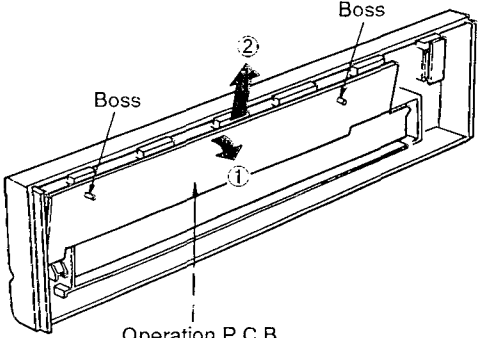
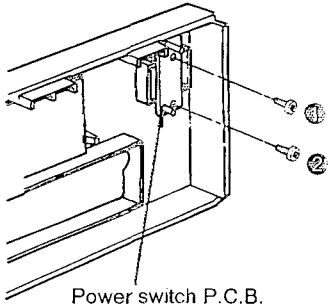
<p>Ref.No. 1</p>	<p>Removal of the cabinet</p>	<p>Ref.No. 2</p>	<p>Removal of the front panel ass'y</p>
<p>Procedure 1</p>		<p>Procedure 1→2</p>	 <p><b>Note on installation</b> Connect the FPC board with the blue line upward.</p>
<p>1. Remove the 6 screws( ❶ ~ ❾ ). 2. Remove the cabinet in the direction of arrow.</p>	<p>1. Pull out the FPC boards from connectors(CN601, CN602).</p>	<p>Ref.No. 3</p>	<p>Ref.No. 4</p>
<p>Procedure 1→2→3</p>	<p>Removal of the operation P.C.B.</p>	<p>Procedure 1→2→3</p>	<p>Removal of the power switch P.C.B.</p>
<p>1. Remove the 10 screws( ❶ ~ ❿ ). 2. Release the 1 claw.</p>		<p>1. Pull the front panel ass'y in both direction of arrow ❶ to unlock it from the projections of the chassis ass'y. 2. Remove the 3 screws( ❶ ~ ❸ ). 3. Pull the front panel ass'y in the direction of arrow ❷.</p>	
<p>3. Tilt the operation P.C.B. in the direction of arrow ❶ and release the bosses. Then, remove the operation P.C.B. in the direction of arrow ❷.</p>		<p>Remove the 2 screws( ❶, ❷ ).</p>	

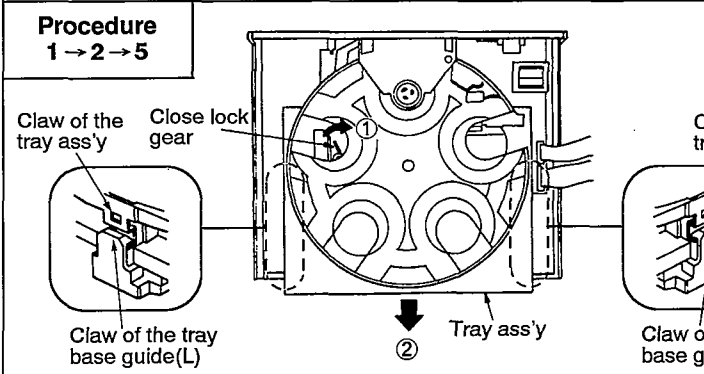
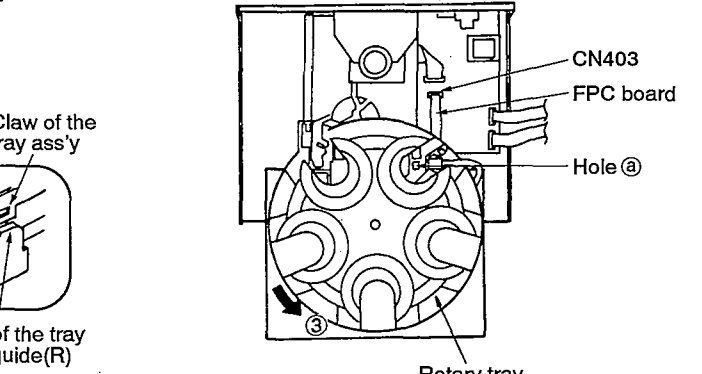
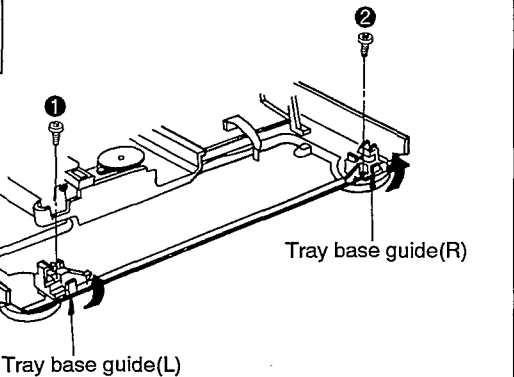
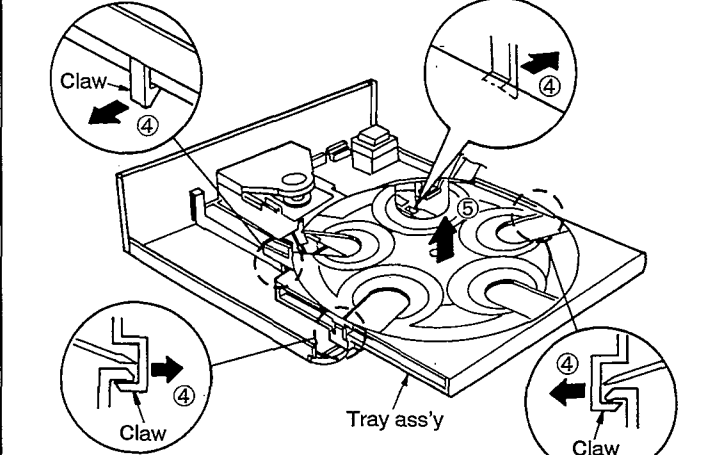
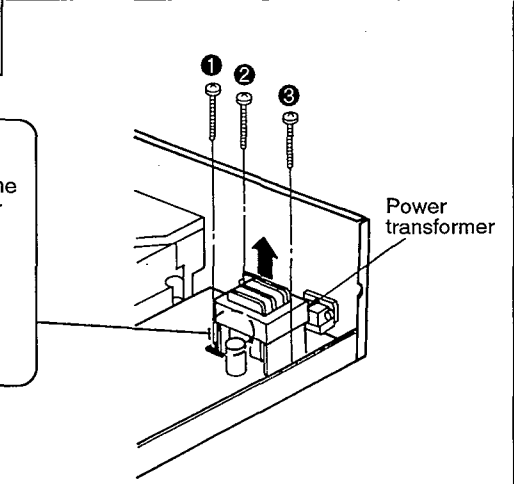
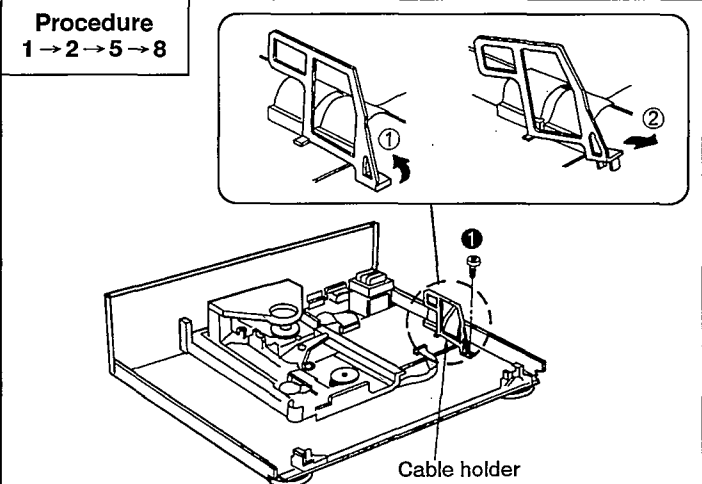
<p><b>Ref.No.</b> 5</p>	<p><b>Removal of the tray ass'y</b></p>		
<p><b>Procedure</b> 1 → 2 → 5</p>			
	<ol style="list-style-type: none"> <li>1. Keep the close lock gear pressed in the direction of arrow ①, and move the tray ass'y in the direction of arrow ②.</li> <li>2. Fit the claw of the tray ass'y in the claw of the tray base guide(L).</li> <li>3. Fit the claw of the tray ass'y in the claw of the tray base guide(R).</li> </ol>		<ol style="list-style-type: none"> <li>4. Pull out the FPC board from connector(CN403).</li> <li>5. Rotate the rotary tray to the position that can be confirmed the hole @ in the direction of arrow ③.</li> </ol>
<p><b>Ref.No.</b> 6</p>	<p><b>Removal of the tray base guide(L) and tray base guide(R)</b></p>		
<p><b>Procedure</b> 1 → 2 → 5 → 6</p>			
	<ol style="list-style-type: none"> <li>1. Remove the 2 screws( ①, ② ).</li> <li>2. Remove the tray base guide(L) and tray base guide(R) in the direction of arrow.</li> </ol>		<ol style="list-style-type: none"> <li>5. Push and release the 4 claws in the direction of arrow ④, and then remove the tray ass'y in the direction of arrow ⑤.</li> </ol>
<p><b>Ref.No.</b> 7</p>	<p><b>Removal of the power transformer</b></p>		<p><b>Ref.No.</b> 8</p>
<p><b>Procedure</b> 1 → 7</p>			
	<ol style="list-style-type: none"> <li>1. Remove the 3 screws( ① ~ ③ ).</li> <li>2. Remove the power transformer in the direction of arrow.</li> </ol>		<ol style="list-style-type: none"> <li>1. Remove the 1 screw( ① ).</li> <li>2. Lift the cable holder in the direction of arrow ①, and then remove it in the direction of arrow ②.</li> </ol>

**Ref.No. 9**  
**Removal of the main P.C.B.**

**Procedure**  
1 → 2 → 5 → 7  
→ 8 → 9

1. Pull out the FPC board from connector(CN301).  
2. Remove 1 connector(CN404).  
3. Remove the 4 screws( ① ~ ④ ).

4. Lift up the main P.C.B. in the direction of arrow ①, and release the 2 ribs on the chassis ass'y. Then, remove the main P.C.B. in the direction of arrow ②.

**Ref.No. 10**  
**Removal of the clamp plate ass'y**

**Procedure**  
1 → 10

1. Remove the 2 screws( ①, ② ).  
2. Push the claw in the direction of arrow ①, and then remove the clamp plate ass'y in the direction of arrow ②.

**Ref.No. 11**  
**Removal of the fixed plate, magnet and clamber**

**Procedure**  
1 → 10 → 11

• Release the 3 claws in the direction of arrow.

**Ref.No. 12**  
**Removal of the loading mechanism ass'y**

**Procedure**  
1 → 2 → 5 → 12

1. Pull out the FPC board from connector(CN301).  
2. Remove 1 connector(CN404).  
3. Remove the 4 screws( ① ~ ④ ).

**Ref.No. 13**  
**Removal of the photo transistor P.C.B.**

**Procedure**  
1 → 13

• Release the 2 claws in the direction of arrow.

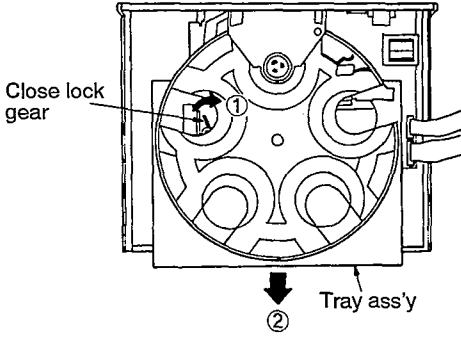
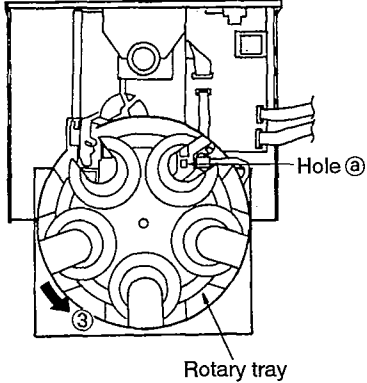
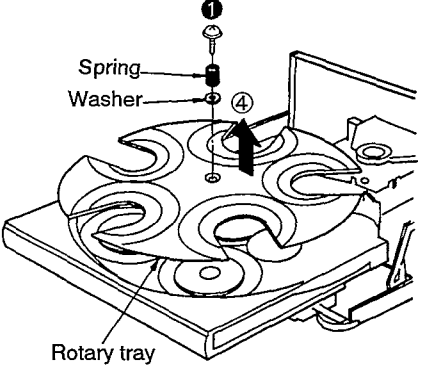
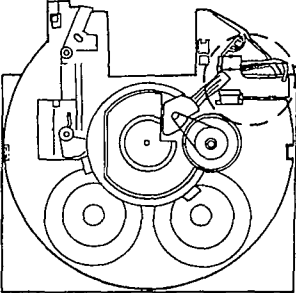
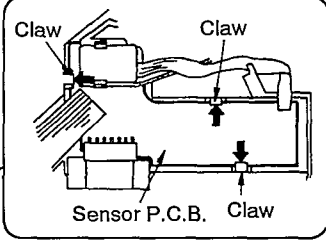
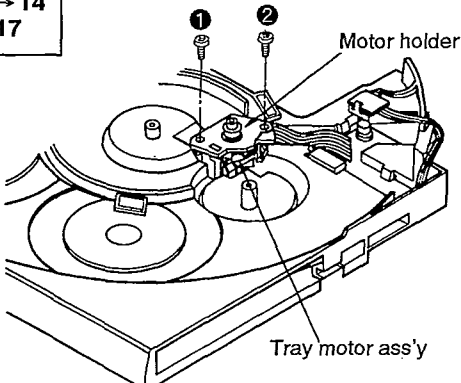
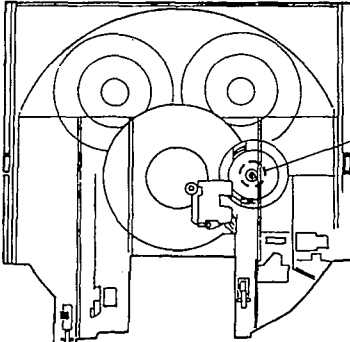
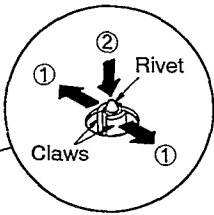
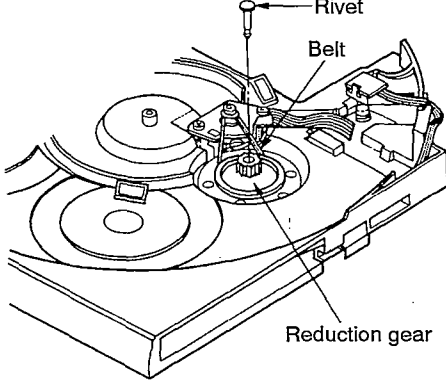
<p><b>Ref.No.</b> 14</p>	<p><b>Removal of the rotary tray</b></p>	
<p><b>Procedure</b> 1 → 2 → 14</p>		
 <p>Close lock gear</p> <p>Tray ass'y</p>	 <p>Hole @</p> <p>Rotary tray</p>	 <p>Spring</p> <p>Washer</p> <p>Rotary tray</p>
<p>1. Keep the close lock gear pressed in the direction of arrow ①, and move the tray ass'y in the direction of arrow ②.</p>	<p>2. Rotate the rotary tray to the position that can be confirmed the hole @ in the direction of arrow ③.</p>	<p>3. Remove the 1 screw (①).</p> <p>4. Remove the spring and washer.</p> <p>5. Remove the rotary tray in the direction of arrow ④.</p>
<p><b>Ref.No.</b> 15</p>	<p><b>Removal of the sensor P.C.B.</b></p>	
<p><b>Procedure</b> 1 → 2 → 5 → 13 → 14 → 15</p>		
	 <p>Claw</p> <p>Claw</p> <p>Sensor P.C.B.</p> <p>Claw</p>	
<p>• Release the 3 claws in the direction of arrow, and remove the sensor P.C.B.</p>		
<p><b>Ref.No.</b> 17</p>	<p><b>Removal of motor holder and tray motor ass'y</b></p>	
<p><b>Procedure</b> 1 → 2 → 5 → 14 → 16 → 17</p>		
 <p>Motor holder</p> <p>Tray motor ass'y</p>		
<p>1. Remove the 2 screws (①, ②).</p> <p>2. Remove the motor holder and tray motor ass'y in the direction of arrow.</p>		
<p><b>Ref.No.</b> 16</p>	<p><b>Removal of reduction gear</b></p>	
<p><b>Procedure</b> 1 → 2 → 5 → 14 → 16</p>		
	 <p>Rivet</p> <p>Claws</p>	
<p>1. Release the 2 claws in the direction of arrow ①, and then push the rivet in the direction of arrow ②.</p>		
 <p>Rivet</p> <p>Belt</p> <p>Reduction gear</p>		
<p>2. Pull out the rivet.</p> <p>3. Remove the belt.</p> <p>3. Remove the reduction gear.</p>		

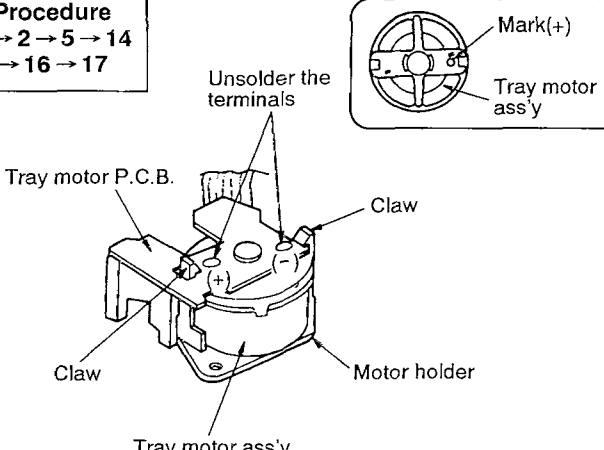
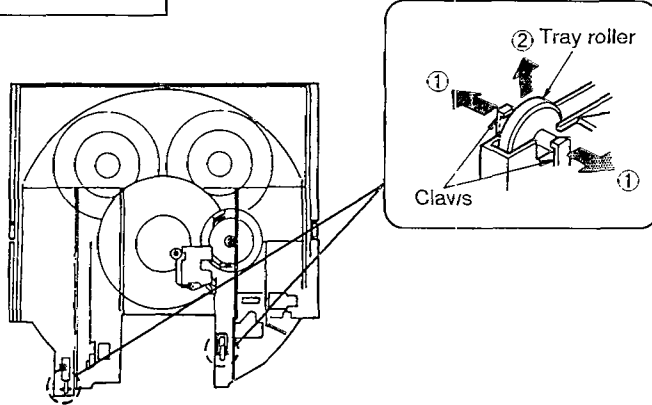
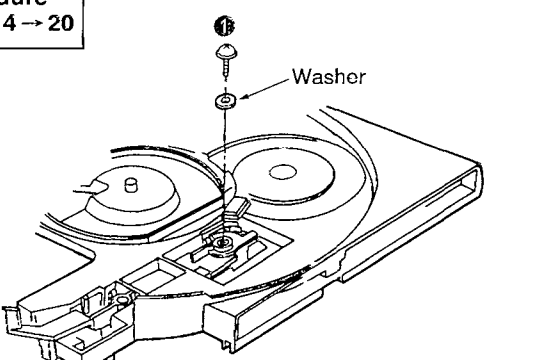
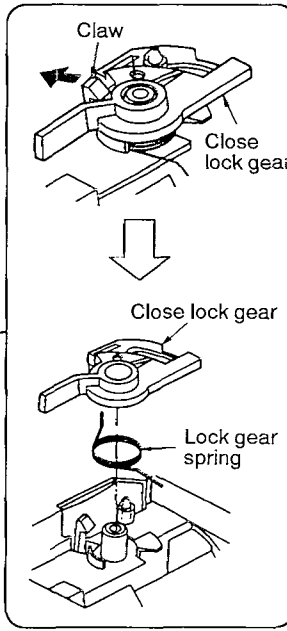
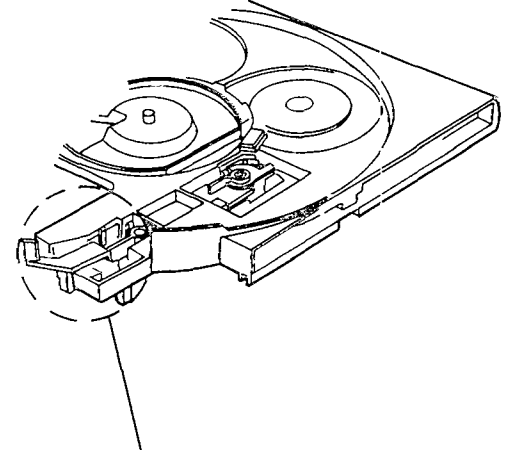
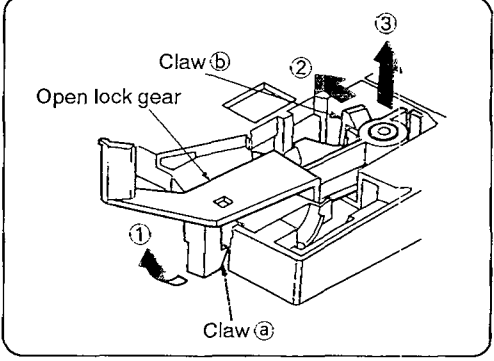
<p><b>Ref.No.</b> 18</p>	<p><b>Removal of the tray motor P.C.B.</b></p>	<p><b>Ref.No.</b> 19</p>	<p><b>Removal of the tray roller</b></p>
<p><b>Procedure</b> 1 → 2 → 5 → 14 → 16 → 17</p>	 <p>Unsolder the terminals</p> <p>Tray motor P.C.B.</p> <p>Claw</p> <p>Claw</p> <p>Motor holder</p> <p>Tray motor ass'y</p> <ol style="list-style-type: none"> <li>1. Release the 2 claw, and then remove the motor holder.</li> <li>2. Unsolder the terminals of the tray motor ass'y.</li> </ol>	<p><b>Procedure</b> 1 → 2 → 14 → 19</p>	 <p>Tray roller</p> <p>Claws</p> <p>Claws</p> <ul style="list-style-type: none"> <li>• Release the 2 claws in the direction of arrow ①, and then remove the tray roller in the direction of arrow ②.</li> </ul>
<p><b>Ref.No.</b> 20</p>	<p><b>Removal of the close lock gear</b></p>	<p><b>Ref.No.</b> 21</p>	<p><b>Removal of the open lock gear</b></p>
<p><b>Procedure</b> 1 → 2 → 14 → 20</p>	 <p>Washer</p> <p>Close lock gear</p> <ol style="list-style-type: none"> <li>1. Remove the 1 screw (❶) and washer.</li> </ol>  <p>Claw</p> <p>Close lock gear</p> <p>Close lock gear</p> <p>Lock gear spring</p> <ol style="list-style-type: none"> <li>2. Release the 1 claw and then remove the close lock gear and lock gear spring.</li> </ol>	<p><b>Procedure</b> 1 → 2 → 5 → 14 → 21</p>	 <p>Open lock gear</p> <p>Claw (a)</p>  <p>Claw (b)</p> <p>Open lock gear</p> <ol style="list-style-type: none"> <li>1. Release the claw (a) of open lock gear in the direction of arrow ①.</li> <li>2. Release the claw (b) of open lock gear in the direction of arrow ②, and then remove the of open lock gear in the direction of arrow ③.</li> </ol>

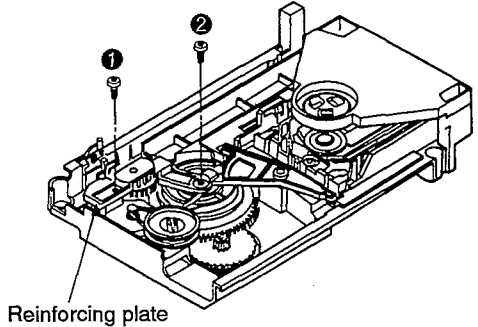
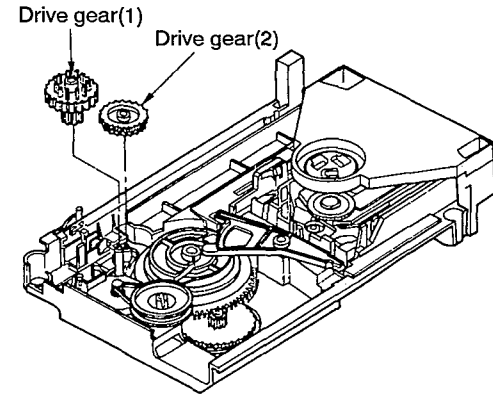
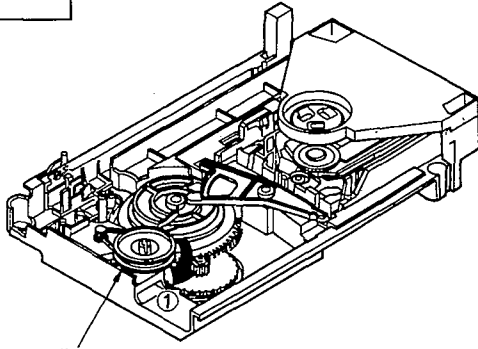
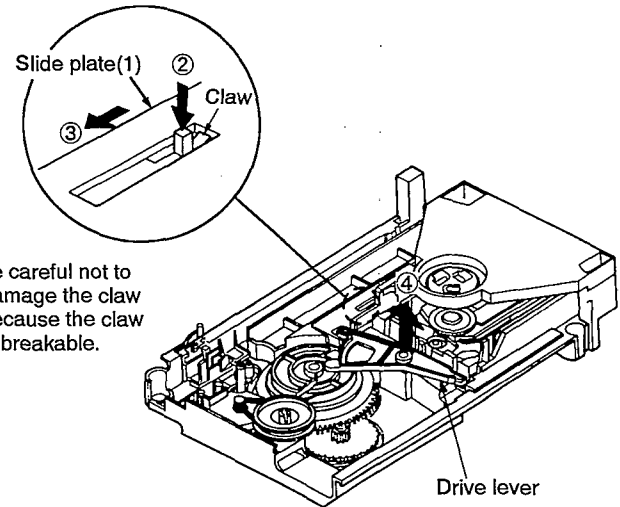
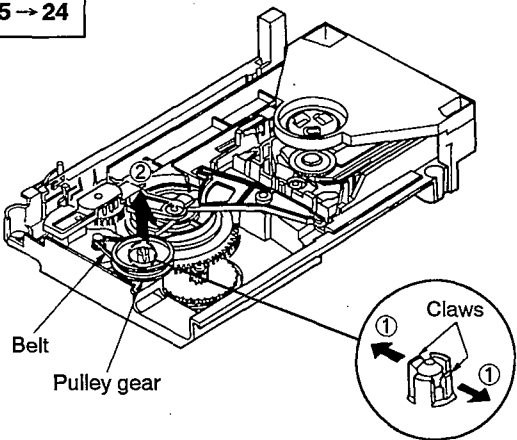
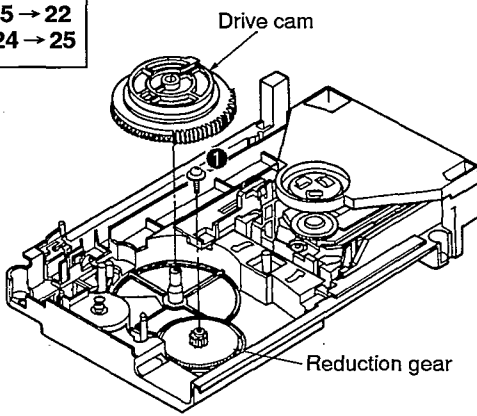
<p><b>Ref.No.</b> 22</p>	<p><b>Removal of the reinforcing plate, drive gear(1) and drive gear(2)</b></p>		
<p><b>Procedure</b> 1 → 2 → 5 → 22</p>	 <p>Reinforcing plate</p> <ol style="list-style-type: none"> <li>1. Remove the 2 screws (①, ②).</li> <li>2. Remove the reinforcing plate.</li> </ol>		 <p>Drive gear(1) Drive gear(2)</p> <ol style="list-style-type: none"> <li>3. Remove the drive gear(1) and drive gear(2).</li> </ol>
<p><b>Ref.No.</b> 23</p>	<p><b>Removal of the drive lever</b></p>		
<p><b>Procedure</b> 1 → 2 → 5 → 22 → 23</p>	 <p>Pulley gear</p> <ol style="list-style-type: none"> <li>1. Rotate the pulley gear to full position in the direction of arrow ①.</li> </ol>		 <p>Slide plate(1) Claw</p> <p><b>Note)</b> Be careful not to damage the claw because the claw is breakable.</p> <p>Drive lever</p> <ol style="list-style-type: none"> <li>2. Push the claw in the direction of arrow ②, and then move the slide plate(1) in the direction of arrow ③.</li> <li>3. Remove the drive lever in the direction of arrow ④.</li> </ol>
<p><b>Ref.No.</b> 24</p>	<p><b>Removal of the pulley gear</b></p>	<p><b>Ref.No.</b> 25</p>	<p><b>Removal of the drive cam and reduction gear</b></p>
<p><b>Procedure</b> 1 → 2 → 5 → 24</p>	 <p>Belt Pulley gear Claws</p> <ol style="list-style-type: none"> <li>1. Remove the belt.</li> <li>2. Release the 2 claws in the direction of arrow ①, and then remove the pulley gear in the direction of arrow ②.</li> </ol>		<p><b>Procedure</b> 1 → 2 → 5 → 22 → 23 → 24 → 25</p>  <p>Drive cam Reduction gear</p> <ol style="list-style-type: none"> <li>1. Remove the drive cam.</li> <li>2. Remove 1 screw (①).</li> <li>3. Remove the reduction gear.</li> </ol>

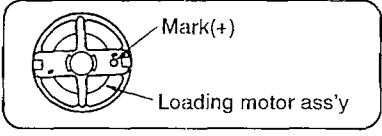
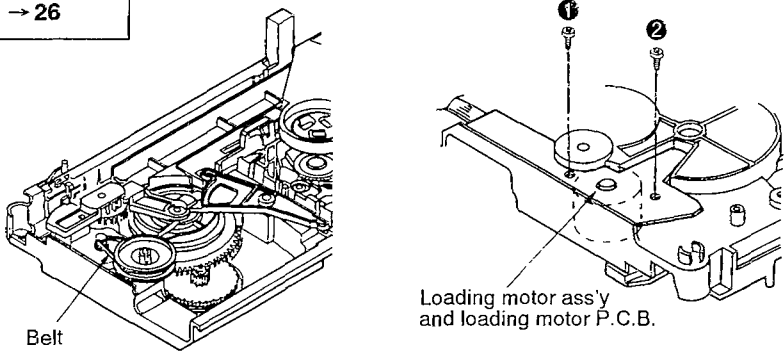
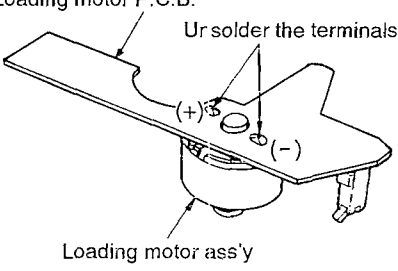
<p><b>Ref.No.</b> 26</p>	<p><b>Removal of the loading motor ass'y and loading motor P.C.B.</b></p>		
<p><b>Procedure</b> 1 → 2 → 5 → 12 → 26</p>			
<p>1. Remove the belt.</p> <p>2. Remove the 2 screws( ❶ ❷ ).</p> <p>3. Remove the loading motor ass'y and loading motor P.C.B.</p> <p>4. Unsolder the terminals of the loading motor ass'y.</p>			

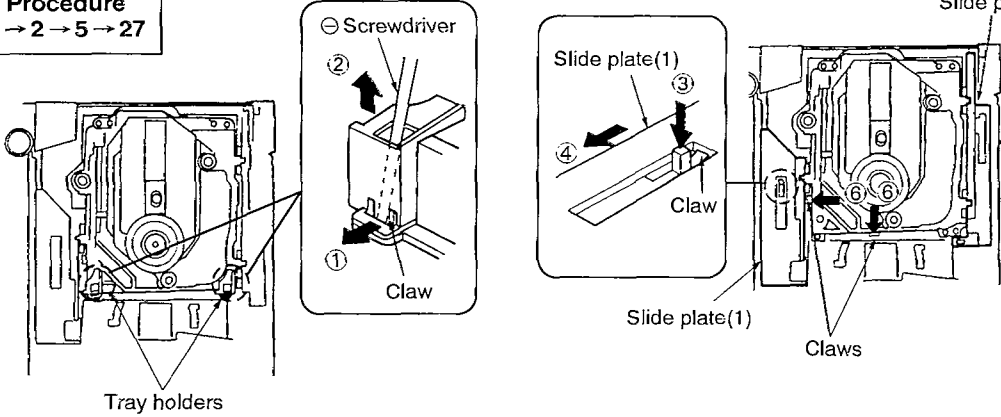
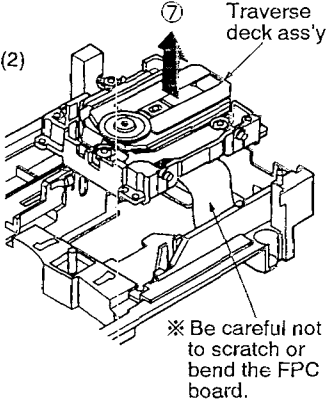
<p><b>Ref.No.</b> 27</p>	<p><b>Removal of the traverse deck ass'y</b></p>		
<p><b>Procedure</b> 1 → 2 → 5 → 27</p>			
<p>1. While pushing the claw of tray holders in the direction ❶ using the ⊖ screwdriver, remove the tray holder in the direction of arrow ❷.</p> <p>2. Push the claw in the direction of arrow ❸, and then move the slide plate(1) in the direction of arrow ❹.</p> <p>3. Move the slide plate(2) in the direction of arrow ❺.</p> <p>4. Release the 2 claws in the direction of arrow ❻, and then remove the traverse deck ass'y in the direction of arrow ❼.</p>			

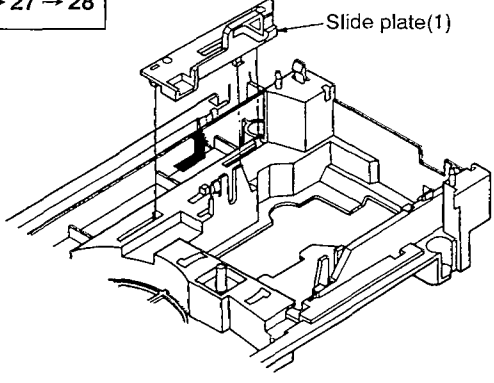
<p><b>Ref.No.</b> 28</p>	<p><b>Removal of the slide plate(1)</b></p>	
<p><b>Procedure</b> 1 → 2 → 5 → 22 → 23 → 27 → 28</p>		
<p>• Remove the slide plate(1) in the direction of arrow.</p>		

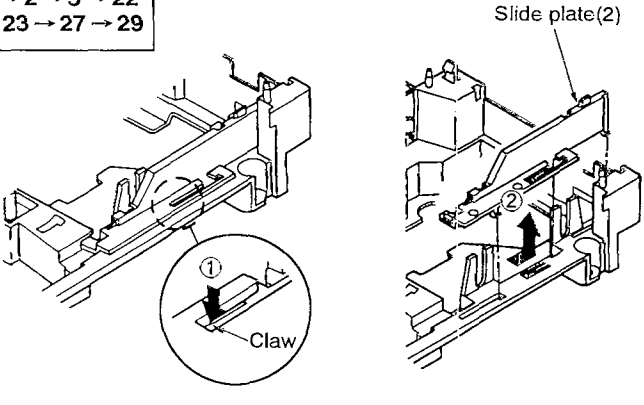
<p><b>Ref.No.</b> 29</p>	<p><b>Removal of the slide plate(2)</b></p>	
<p><b>Procedure</b> 1 → 2 → 5 → 22 → 23 → 27 → 29</p>		
<p>• Push the claw in the direction of arrow ❶, and then remove the slide plate(2) in the direction of arrow ❷.</p>		

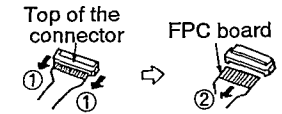
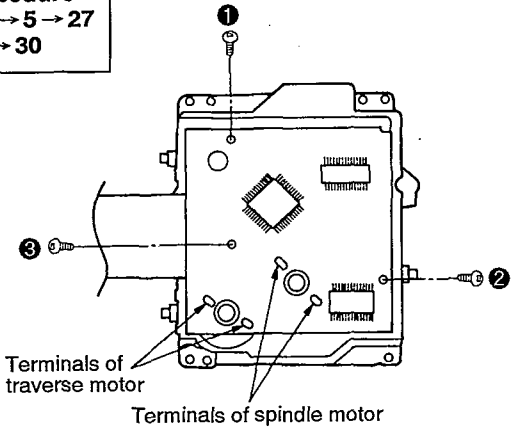
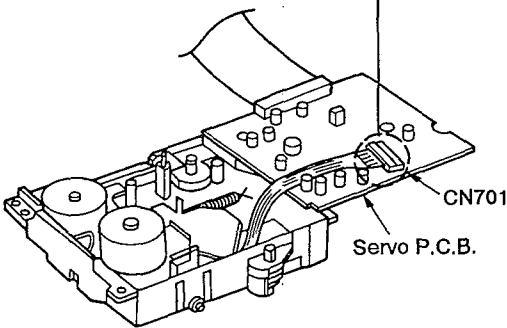
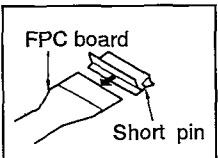
<p><b>Ref.No.</b> 30</p>	<p><b>Removal of the servo P.C.B.</b></p>	<p>1. Push the top of the connector in the direction of arrow ①. 2. Remove the FPC board in the direction of arrow ②.</p> 
<p><b>Procedure</b> 1 → 2 → 5 → 27 → 30</p>	 <p>1. Remove the 3 screws (① ~ ③). 2. Unsolder the 2 terminals of spindle motor. 3. Unsolder the 2 terminals of traverse motor.</p>	 <p>4. Remove the FPC board from connector(CN701). <b>Caution:</b> Insert a short pin into the traverse unit FPC board. (Refer to "handling precautions for traverse deck" on page 8.)</p> 

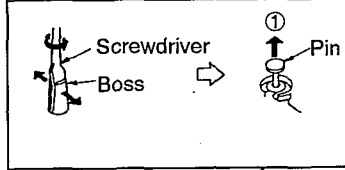
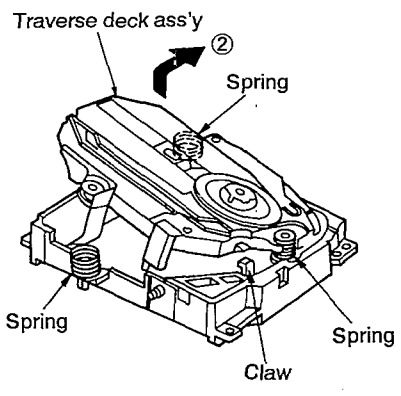
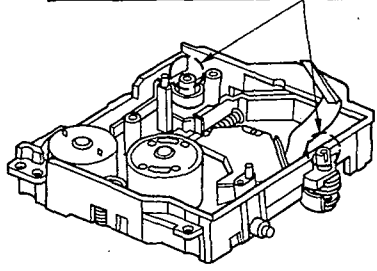
<p><b>Ref.No.</b> 31</p>	<p><b>Removal of the traverse deck ass'y</b></p>	 <p>1. Widen the bosses by using a regular screwdriver or similar object. 2. Pull out the pins.</p>  <p>2. Release the claw, and then remove the traverse deck ass'y in the direction of arrow ②.</p> <p><b>Caution:</b> Be careful not to lose the 3 springs because those will also be removed on removal of the traverse deck ass'y.</p>
<p><b>Procedure</b> 1 → 2 → 5 → 27 → 30 → 31</p>	 <p>1. Remove the 2 pins in the direction of arrow ①.</p>	

**■ INSTALLATION OF SERVO P.C.B.**

- When installing servo P.C.B., move the optical pickup to the more external side than the mark (▲).  
(When the optical pickup is not moved, the switch(S701) on the servo P.C.B. may be broken.)
  - Connect the FPC board to the connector(CN701).
  - Install the servo P.C.B. to the traverse unit with 3 screws (① ~ ③).
  - Solder the 2 terminals of the traverse motor and the 2 terminals of the spindle motor.
- Note:**
- Insert the FPC board into the connector and lock securely.
  - After installing the motor with screws, solder each motor terminal.

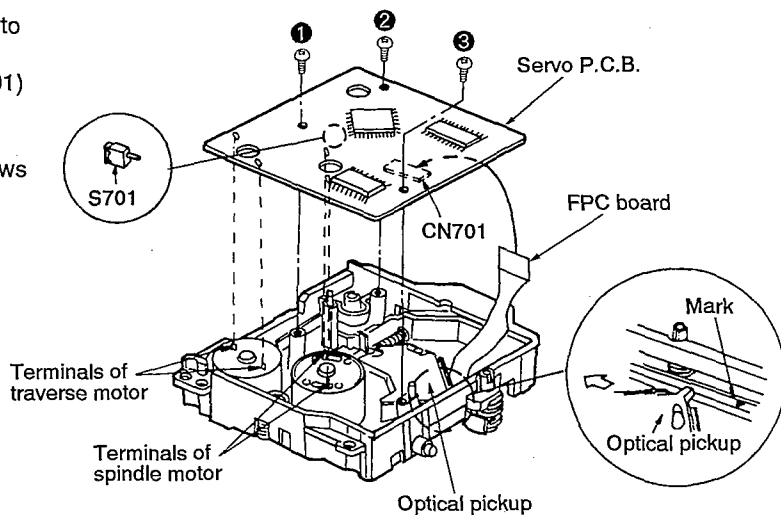



### Installation of the traverse deck ass'y

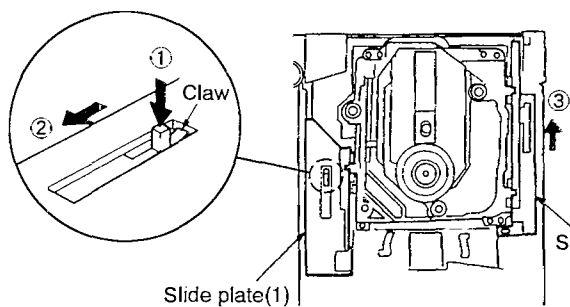

1. Push the claw in the direction of arrow ①, and then move the slide plate(1) in the direction of arrow ②.
2. Move the slide plate(2) in the direction of arrow ③.

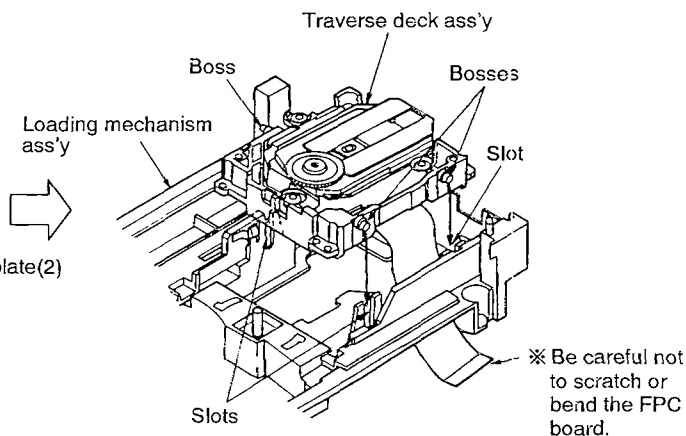

3. Align the 3 bosses of traverse deck ass'y with the slots of loading mechanism ass'y.

### Installation of the drive lever

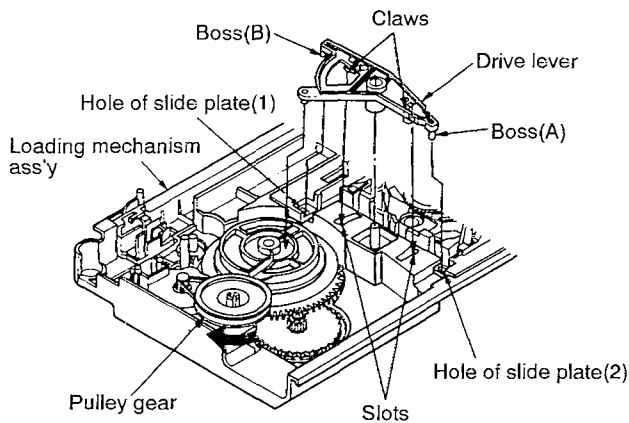

1. Rotate the pulley gear to full position in the direction of arrow.
2. Align the boss(A) with the hole of slide plate(2).
3. Align the boss(B) with the hole of slide plate(1).
4. Align the claws of drive lever with the slots of loading mechanism ass'y.

### Positioning of the drive cam

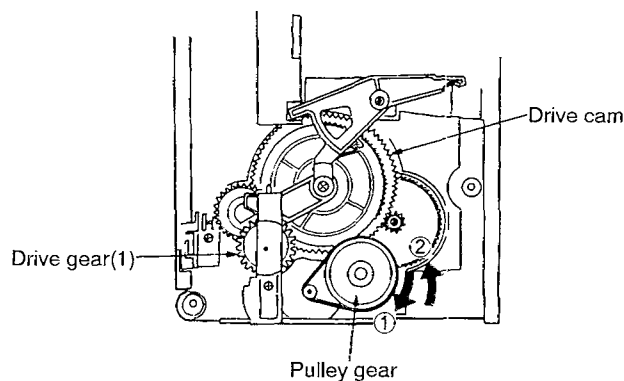

1. Rotate the pulley gear to full position in the direction of arrow ①.
2. Then, rotate the pulley gear in the direction of arrow ②.
3. When the drive gear(1) stops rotating, turn off that pulley gear is rotating.

### Installation of the tray ass'y

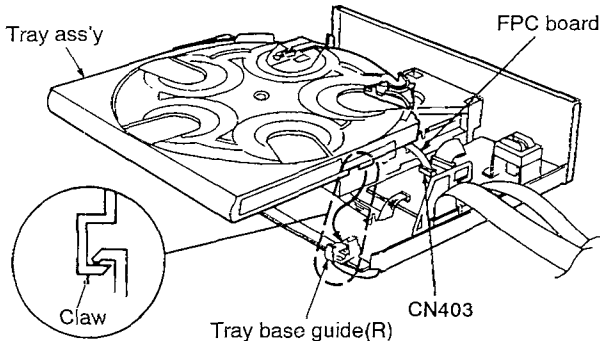

1. Attach the FPC board to the connector(CN403).
2. Fit the claws on the right side of the tray ass'y underneath the claws on the tray base guide(R).
3. Fit the claws on the right side of the tray ass'y underneath the claws on the tray base guide(L).

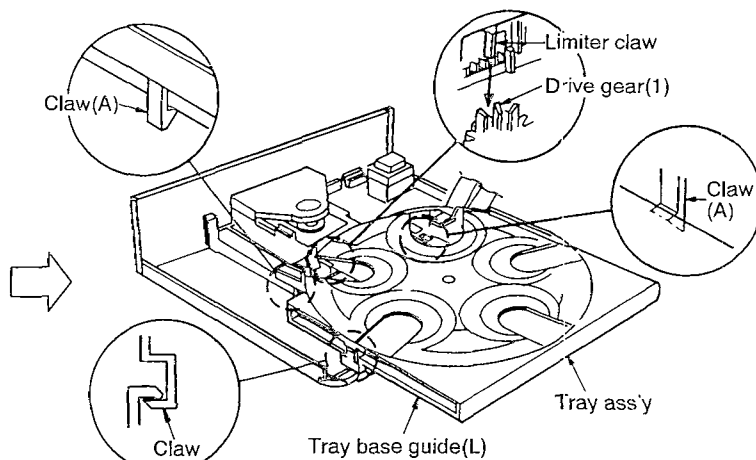

4. Fit the limiter claw on the tray ass'y between the teeth of the drive gear(1).
5. Catch the 2 claws(A) with the loading mechanism ass'y.
6. After installing the tray ass'y, check that it moves smoothly.

## HOW TO CHECK THE MAIN AND SERVO P.C.B.

1. Remove the cabinet. (See Ref.No.1 of the disassembly instructions.)
2. Remove the front panel ass'y. (See Ref.No.2 of the disassembly instructions.)
3. Remove the tray ass'y. (See Ref.No.5 of the disassembly instructions.)
4. Remove the cable holder. (See Ref.No.8 of the disassembly instructions.)
5. Remove the clamp plate ass'y. (See Ref.No.10 of the disassembly instructions.)
6. Remove the fixed plate, magnet and clamber. (See Ref.No.11 of the disassembly instructions.)

### ● Check the main P.C.B.

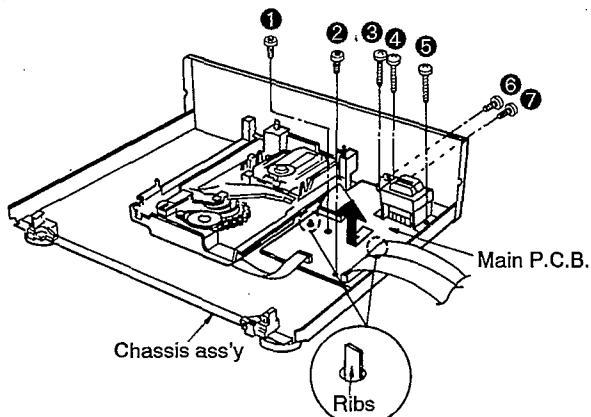

Fig. 1

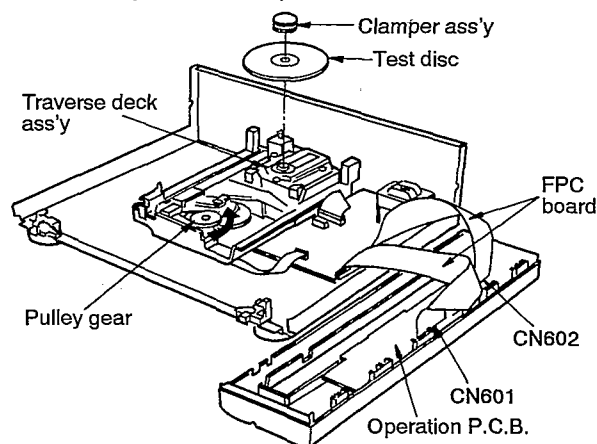

Fig. 2

7. Remove the 7 screws (1 ~ 7).
8. Lift up the main P.C.B. to release the 2 ribs of chassis ass'y, and then remove the main P.C.B. in the direction of arrow.

9. Rotate the pulley gear in the direction of arrow until traverse deck ass'y comes up.
10. Place the test disc and secure it by using the clamber ass'y.
11. Connect the 2 FPC board (CN601, CN602) as shown in Fig. 2.
12. Set up the main P.C.B.
13. Connect the main P.C.B. ground terminal (line out terminal) to the chassis ass'y with a lead wire.

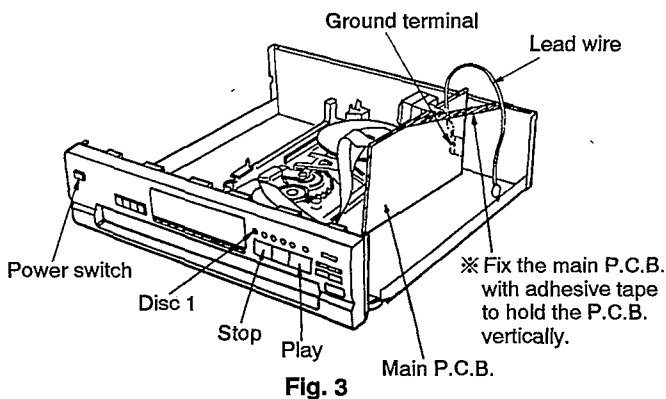

Fig. 3

### How to play the disc

14. Set the unit in the test mode as follows:  
(hold the **play**, **stop** and **disc 1** keys(3 keys) on and set the power switch to ON.)
15. Press the **play** key and play the test disc.
16. When checking the soldered surface of the main P.C.B., do as shown in Fig. 3.

### ● Check the servo P.C.B.

7. Remove the loading mechanism ass'y. (See Ref.No.12 of the disassembly instructions.)
8. Remove the traverse deck ass'y. (See Ref.No.27 of the disassembly instructions.)

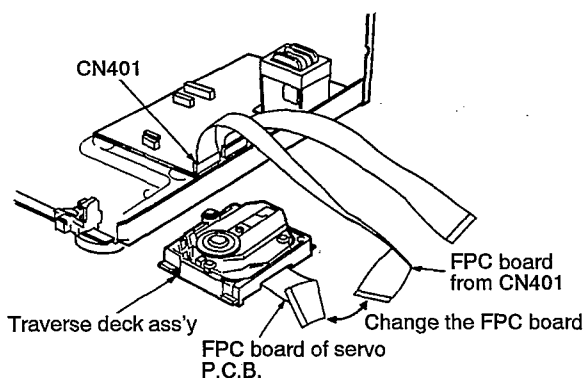

9. Replace the FPC board of servo P.C.B. to the FPC board (CN401) of main P.C.B.

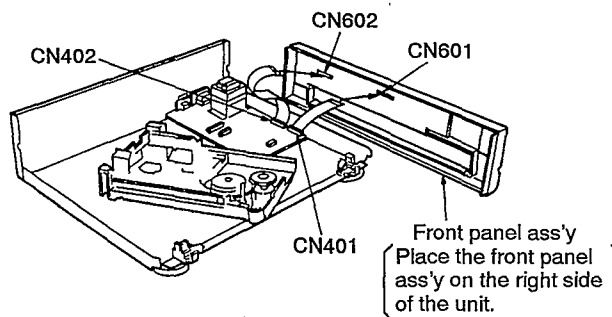

10. Connect the FPC boards as shown in above.  
{ Between CN401 and CN601 }  
{ Between CN402 and CN602 }

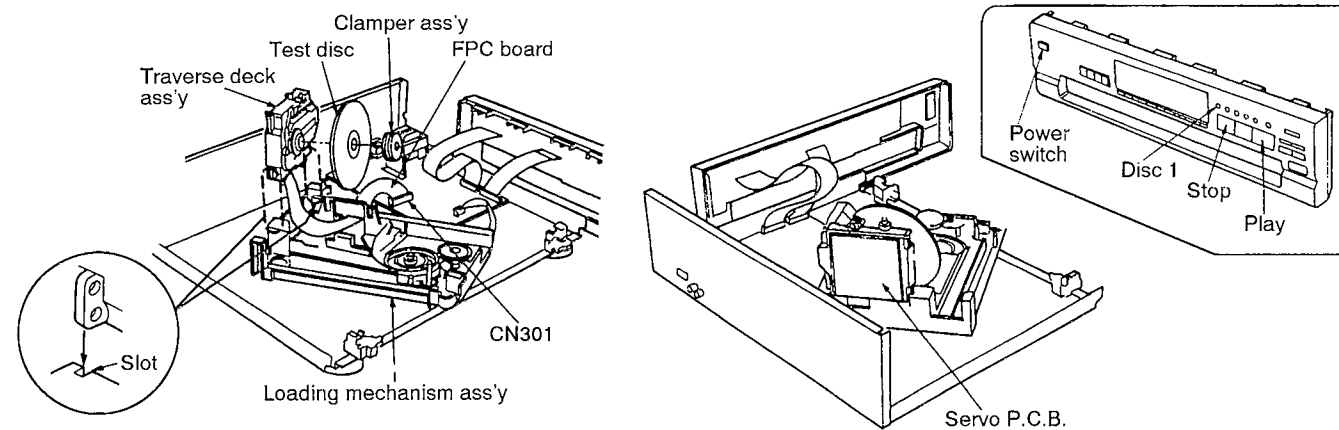

11. Insert the traverse deck in the slot of loading mechanism ass'y
12. Connect the FPC board of servo P.C.B. to the connector (CN301) of main P.C.B.
13. Set the test disc on the traverse deck ass'y, and then fix the traverse deck ass'y with clamber ass'y.

**Notes:**

- After completing the check, restore the replaced FPC boards to their original positions.

## OPERATING THE UNIT WITHOUT THE FRONT PANEL ASS'Y (OPERATION P.C.B. AND KEYS)

### A Turning off the back-up power to the microprocessor(IC 401)

1. Unplug the AC lead.
2. Short the ends of the C401 jumpers at 10 Ω (5W) resistance for at least 1 second.

### B Turning the power on again

1. Plug the AC lead back in.
2. Short the between the following jumpers simultaneously:
  - The D401 cathode and R401 from IC401 (equivalent to pressing the STOP button).
  - The D401 cathode and R403 from IC401 (equivalent to pressing the PLAY button).
  - The D402 cathode and R401 from IC401 (equivalent to pressing the DISC 1 button).
3. Keeping the above shorts in place, short between the D404 cathode and R405 from IC401 for 1 second to turn on the power to the main unit.
4. Remove the shorts placed in step 2.

### C Using the machine

- To play, short between the D401 cathode and R403 from IC401 (equivalent to pressing the PLAY button).
- To pause, short between the D401 cathode and R402 from IC401 (equivalent to pressing the PAUSE button).
- To stop, short between the D401 cathode and R401 from IC401 (equivalent to pressing the STOP button).
- To move forward, short between the D402 cathode and R402 from IC401 (equivalent to pressing the F.SKIP button).
- To move backward, short between the D402 cathode and R403 from IC401 (equivalent to pressing the R.SKIP button).
- To search in the forward direction, short between the D403 cathode and R402 from IC401 (equivalent to pressing the F.SEARCH button).
- To search in the backward direction, short between the D403 cathode and R403 from IC401 (equivalent to pressing the R.SEARCH button).

### D Finishing off

1. Unplug the AC lead.
2. Short the ends of the C401 jumpers at 10 Ω (5W) resistance.

### How to play the disc

14. Set the unit in the test mode as follows: (hold the **play**, **stop** and **disc 1** keys(3 keys) on and set the power switch to ON.)
15. Press the **play** key and play the test disc.
16. When checking the soldered surface of the servo P.C.B., do as shown in above.

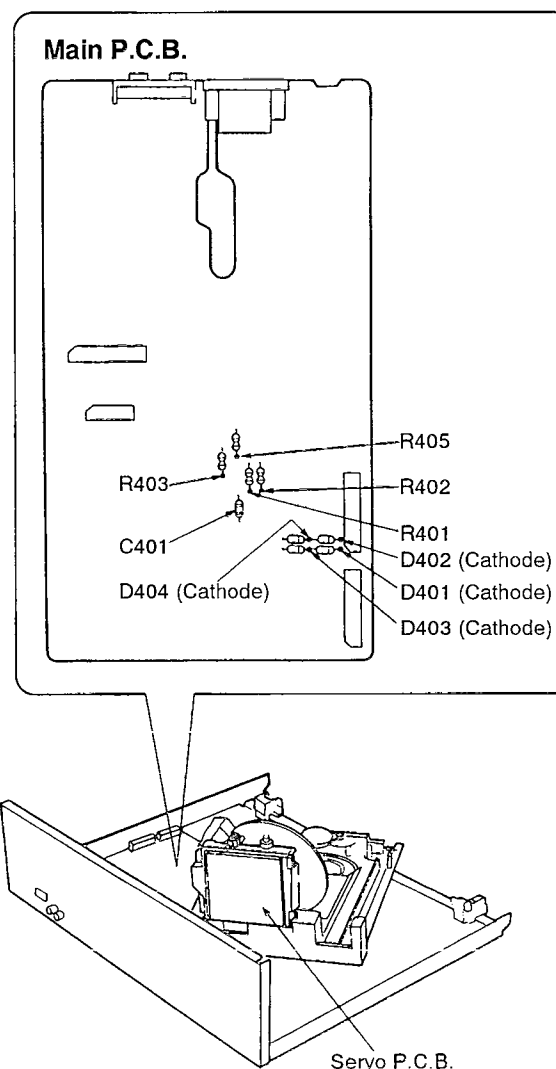

## REPLACEMENT OF THE FOOT

1. Remove the 4 heat melted posts on the Bottom board ass'y with a pair of nippers or similar tool.
2. To replace the foot(RKA0053-A) on the Bottom board ass'y melt the 4 posts with a soldering iron or install it with a screw (XTB3+6J).

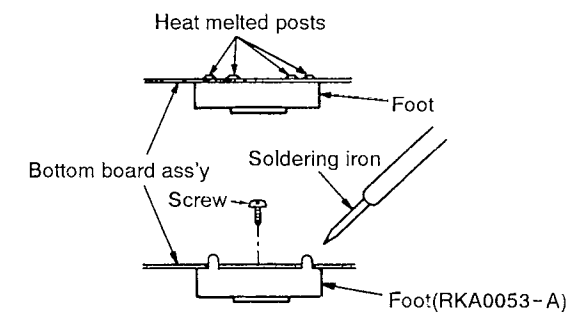

## DISPLAY FUNCTION OF AUTOMATICALLY-ADJUSTED RESULTS (SELF-CHECK FUNCTION)

The unit contains a function which displays the result of the automatically adjustment of the servo circuits (tracking, focus servo, etc.) as an error code on the FL display. The error code display serves as a repair guide showing the automatically adjustment circuit is at fault. The procedures for displaying the error codes are given below.

### • Procedures to display the error code

- (1) Procedure to display the error code before disassembly (finished unit)
  1. When the **POWER** key is pressed while holding down the **STOP** (■), **PAUSE** (■) and **PLAY** (▶) keys simultaneously, the FL display illuminates, release the power turns on.
  2. When the FL display illuminates, release the **STOP** (■), **PAUSE** (■) and **PLAY** (▶) keys.
  3. Press the **OPEN/CLOSE** (▲) key to open the disc tray and load the test disc (SZZP1054C).
  4. Press the **PLAY** (▶) key to start the play operation.
  5. After the time display appears, press the **STOP** (■) key to display the error code. (e.g. E-0)
  6. The error code display can be used as a repair guide showing which servo circuit is at fault. (See Error Code Based Troubleshooting.)
- (2) Procedure to display the error code when disassembled
  1. Prepare the unit as described in "How to Check the Main and Servo P.C.B." on pages 18, 19.
  2. Press the **POWER** key while holding down the **STOP** (■), **PLAY** (▶) and **DISC 1** keys simultaneously.
  3. When the FL display illuminates, release the **STOP** (■), **PLAY** (▶) and **DISC 1** keys.
  4. Load the test disc (SZZP1054C) on the turntable and secure it with the clamber ass'y.
  5. Perform steps 4 and 5 in section (1) above.

### • Error code based troubleshooting

(Refer to next page.)

※ The unit is satisfactory if the error code is E-0 of E-2.  
 ※ Before testing, check that the test disc is free of scratches and dirt and optical pickup is clean.

### DIGITAL SERVO SYSTEM

FL error code display	Symptom	Probable cause	Signal to check		Normal the values of voltage and waveform	
			Signal name	Location	PLAY	STOP
E-1	Focus and tracking offset adjustments did not complete in the specified time period.	① Clocks X1 and X2, power supply VDD, and reset/RST, all on IC702 ② MDATA, MCLK, MLD, and SENSE signals to/from the mechanism controller	MDATA	IC702 ⑧ pin		4.8V
			MCLK	IC702 ⑦ pin		4.8V
			MLD	IC702 ⑨ pin		0V
			SENSE	IC702 ⑩ pin		0V
			/RST	IC702 ⑪ pin		4.9V
			X1	IC702 ⑫ pin		1.1V
E-3 E-5 E-7 E-9 E-B E-D E-F	Disc play unstable	① Scratches or contaminants on disc surface ② Focus and tracking servo circuits (check waveforms, voltages, and part constants.) ③ Spindle driver circuit ④ Optical pickup	FE	IC702 ⑬ pin		2.4V
			TE	IC702 ⑭ pin		2.4V
			FOD	IC702 ⑮ pin	2.4V	2.4V
			TRD	IC702 ⑯ pin	2.4V	2.4V
			KICK	IC702 ⑰ pin	2.4V	2.4V
			/FLOCK	IC702 ⑱ pin	0V	4.9V
			/RF DET	IC702 ⑲ pin	0V	4.8V
			RF	TJ701		3.4V
			STAT	IC702 ⑳ pin	3.5V	0V
			FBAL	IC702 ㉑ pin	2.5 ± 1.25V	2.5 ± 1.25V
			E-4 E-6 E-C E-E	Best Eye (PD Balance) adjustment diode not complete in the specified time period.	① Scratches or contaminants on disc surface ② Focus and Tracking servo circuit (check waveforms, voltages, and part constants.) ③ Optical pickup	RF
FE	IC702 ⑳ pin					0V
/TLOCK	IC702 ㉒ pin	0V				0V
E-8 E-A	Focus or Tracking gain adjustment did not complete in the specified time period.	① Scratches or contaminants on disc surface ② Focus and Tracking servo circuit (check waveforms, voltages, and part constants.) ③ Optical pickup	FE	IC702 ⑳ pin		2.4V
			TE	IC702 ㉓ pin		2.4V
			/TLOCK	IC702 ㉔ pin	0V	0V
			OFT	IC702 ㉕ pin	0V	0V

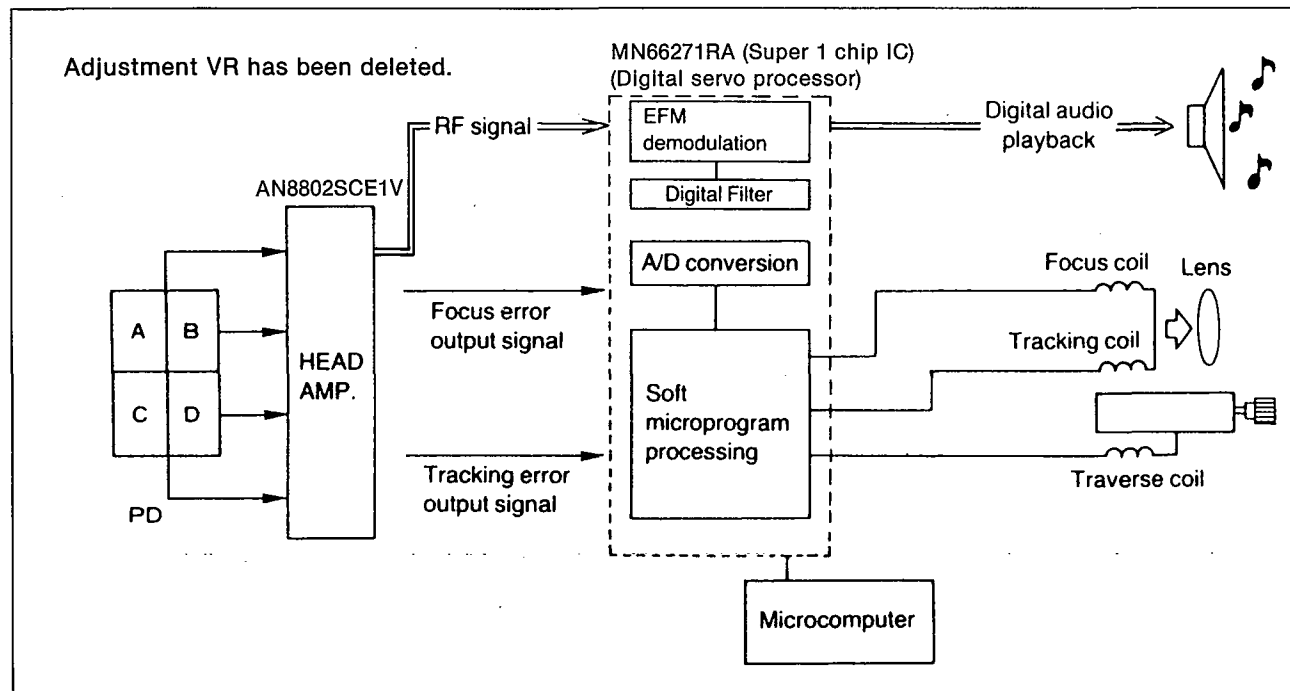

The following flow chart shows the sequence of automatic adjustments.

#### Flow chart automatic adjustment sequence

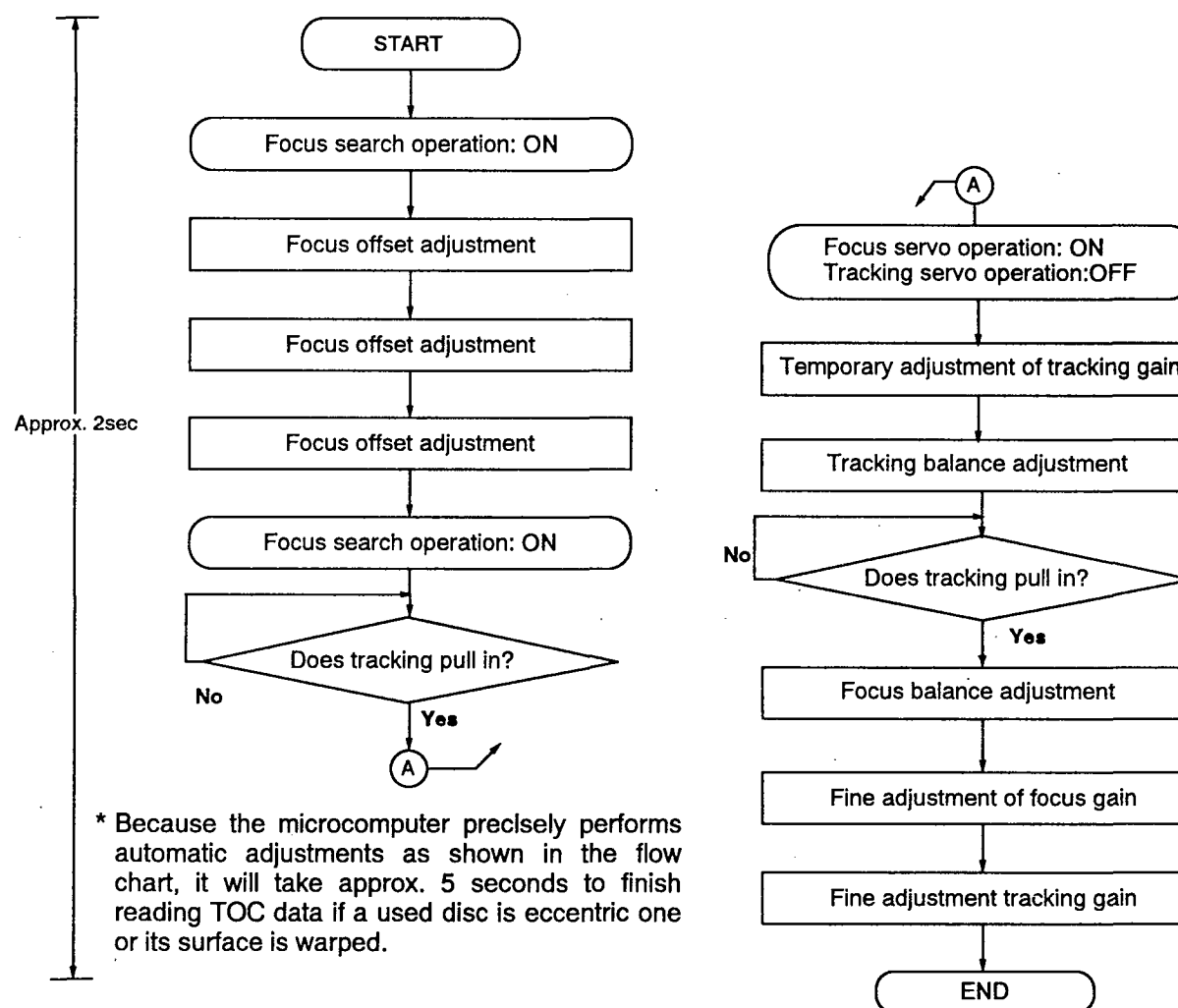

\* Because the microcomputer precisely performs automatic adjustments as shown in the flow chart, it will take approx. 5 seconds to finish reading TOC data if a used disc is eccentric one or its surface is warped.

# ■ TROUBLESHOOTING GUIDE

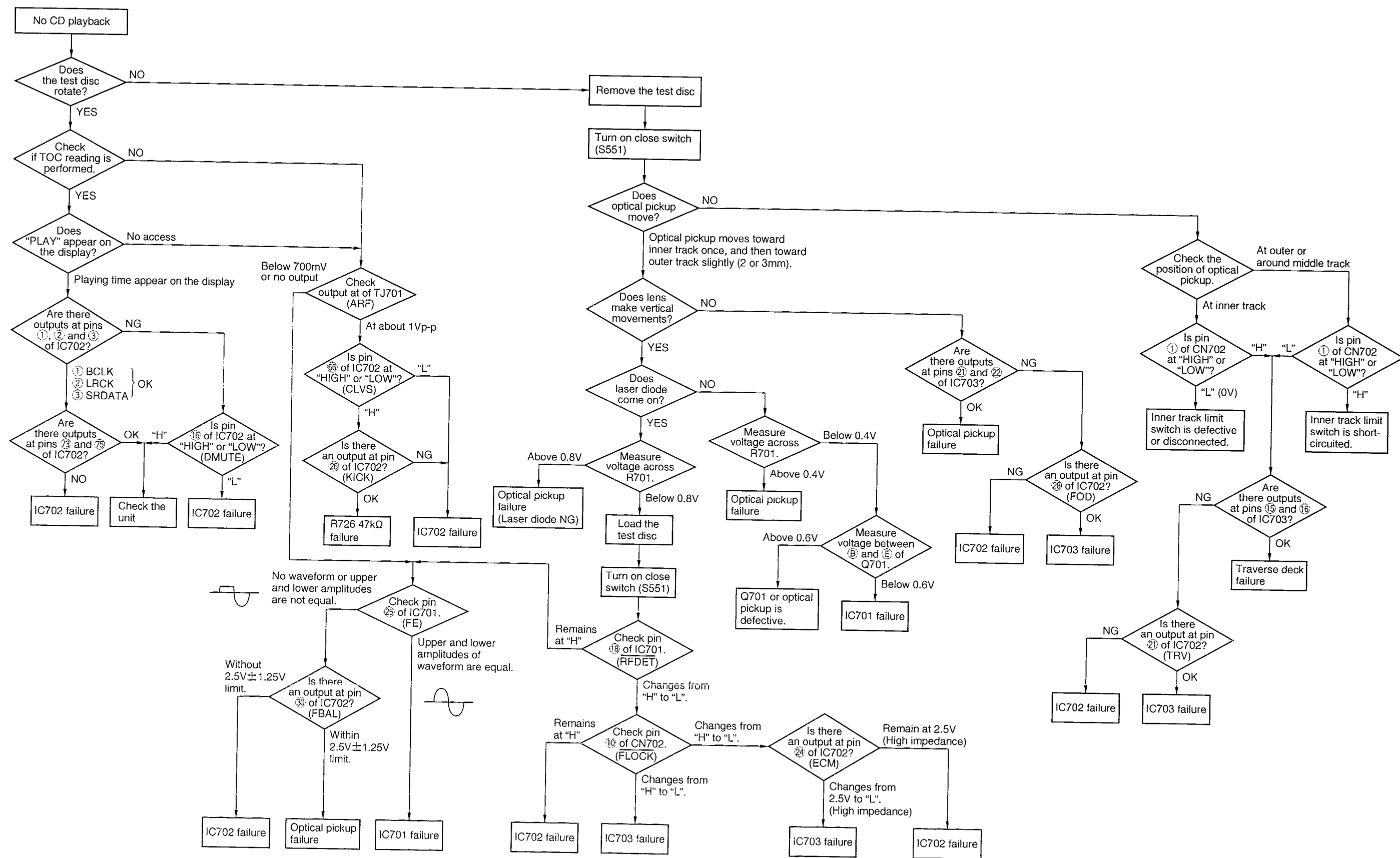

## MEASUREMENTS AND ADJUSTMENTS

**Warning:** This product uses a laser diode. Refer to caution statements on page 2.  
**ACHTUNG:** • Die Lasereinheit nicht zerlegen.  
 • Die Lasereinheit darf nur gegen eine vom Hersteller spezifizierte Einheit ausgetauscht werden.

### Measuring Instruments and Special Tools

- \* Test discs
  1. Playability test disc (SZZP1054C)
  2. Uneven test disc (SZZP1056C)
- \* Musical program disc (ordinary)
- \* Dual-beam oscilloscope with bandwidth of 30MHz or better (with EXT. trigger and 1:1 probe).
- \* Allen wrench (M2.0) (SZZP1101C)
- \* Lock paint (RZZ0L01)

### (2) CHECK OF PLAY OPERATION AFTER ADJUSTMENT

#### \* Checking Skip Search

1. Play an ordinary musical program disc.
2. Press the skip button to check for normal skip search operation (in both the forward and reverse directions).

#### \* Checking Manual Search

1. Play an ordinary musical program disc.
2. Press the manual search button to check for smooth manual search operations at either low or high speed (in both the forward and reverse directions).

#### \* Checking Playability

1. Play the 0.7mm black dot and the 0.7mm wedge on the playability test disc (SZZP1054C) and verify that no sound skip or noise occurs.
2. Play the middle tracks of the uneven test disc (SZZP1056C) and verify that no sound skip or noise occurs.

## PREPARATION

1. Remove the cabinet and front panel ass'y (refer to "disassembly instructions" Ref. No. 1, 2).
2. Set the power switch to ON and press the open/close key to close the loading drawer.
3. Press the play key and when the traverse deck reaches its height position, set the power switch to OFF.
4. Remove the tray ass'y (refer to "disassembly instructions" Ref. No. 5).
5. Remove the clamp plate, fixed plate, magnet and clumper (refer to "disassembly instructions" Ref. No. 10, 11).
6. Place the test disc and secure it by using clumper ass'y. (Refer to Fig. 1) (refer to "disassembly instructions" Ref. No. 11).
7. Set the unit in the test mode as follows: (hold the **play**, **stop** and **disc 1** keys (3 keys) on and set the power switch to ON.)
8. Press the **play** key and play the test disc.
9. Follow the adjustment procedure.

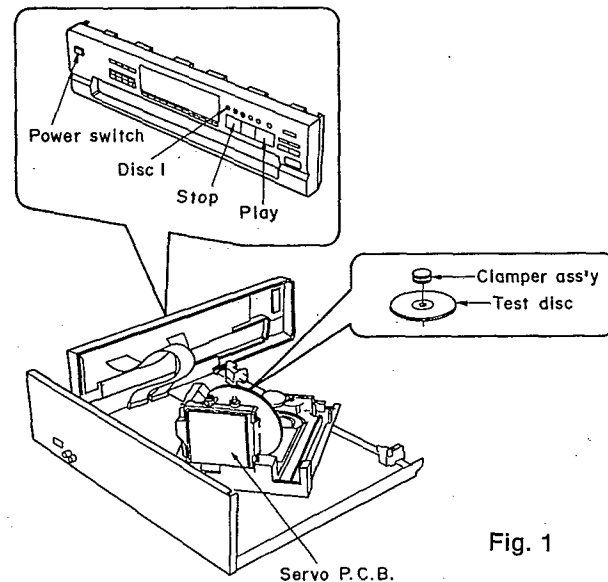
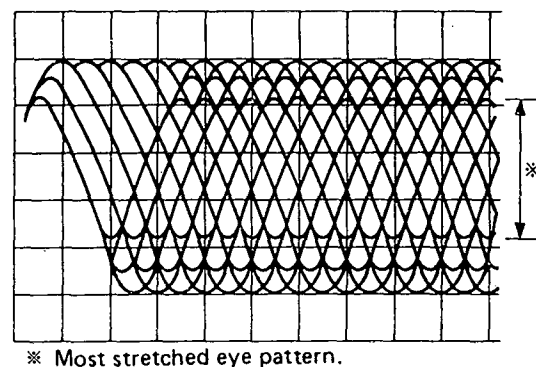

Fig. 1

### (1) MECHANICAL ADJUSTMENT

1. Connect the oscilloscope's CH. 1 probe across **TJ701** (+) and **TJ702** (VREF) on the servo P.C.B. (Refer to Fig. 3 on page 26)  
**Oscilloscope setting:** VOLT ..... 200mV  
 SWEEP ..... 0.5μs.  
 Input coupling..... AC
2. Switch the player power **ON**, and play track 19 on the test disc (SZZP1056C). (Playing any other track will prevent the HEX screws from being accessed.)
3. Leave the player in play mode and place it as shown Fig. 3.
4. Alternately adjust the two HEX screws with the 2.0mm allen wrench (SZZP1101C) until the vertical fluctuation of RF signal is minimized and the eye pattern is most stretched. (Refer to Fig. 2)
5. After completing the adjustment, lock the HEX screws with lock paint (RZZ0L01).



\* Most stretched eye pattern.

Fig. 2

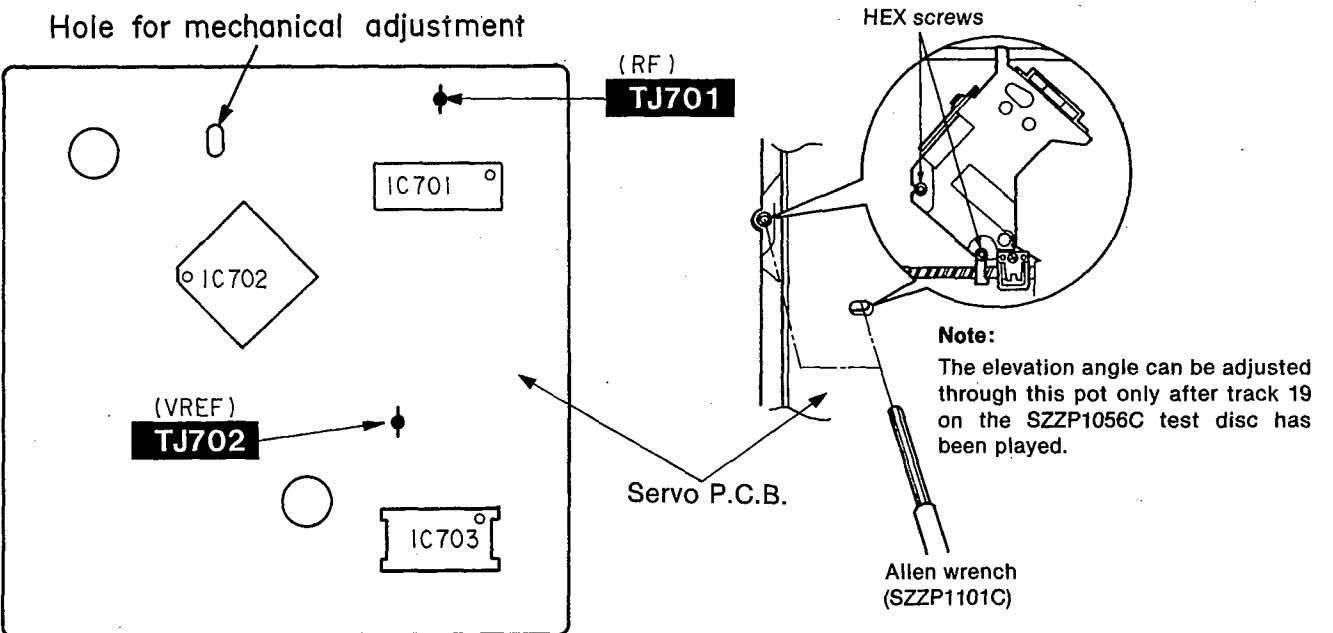

Fig. 3

## ■ TERMINAL FUNCTION OF IC'S

### • IC701 (AN8802SCE1V): Servo amp

Pin No.	Mark	I/O Division	Function
1	PDAD	I	Photo detector Bch input without delay
2	PDA	I	Photo detector Ach input without delay
3	LPD	I	Laser PD signal
4	LD	O	Laser power auto control output
5	AMPI	I	RF amp terminal
6	V <sub>cc</sub>	I	Power supply terminal
7	AMPO	O	RF amp signal
8	CAGC	I	AGC detection capacitor input
9	ARF	O	RF signal
10	CENV	I	RF detect capacitor connection terminal
11	CEA	I	HPF-AMP capacitor connection terminal
12	GND	—	GND terminal
13	LDON	I	LD APC ON/OFF ("H": ON, "L": OFF)
14	TES	I	Tracking error shunt input ("H": shunt)
15	PLAY	I	Play signal ("H": ON, "L": OFF)
16	WVEL	I	Double velocity ("H": double, "L": single)

Pin No.	Mark	I/O Division	Function
17	BDO	O	Dropout detection control
18	/RFDET	O	RF det. signal ("L": det.)
19	CROSS	O	Tracking error zero cross output
20	OFTR	O	Off track detection ("H": det.)
21	VDET	O	Oscillation det. signal ("H": det.)
22	ENV	O	Envelope output terminal
23	TEBPF	I	Oscillation detect input terminal (Not used, open)
24	TE	O	Tracking error signal
25	FE	O	Focusing error signal
26	PTO	O	Potention amp output
27	PTI	I	Potention amp input
28	TBAL	I	Tracking balance adj. Input
29	FBAL	I	Focus balance adj. Input
30	VREF	O	Reference voltage output
31	PDB	I	Photo detector Ach input with delay
32	PDBD	I	Photo detector Bch input with delay

### • IC703 (AN8389SE1): Focus coil/tracking coil/traverse motor/spindle motor drive

Pin No.	Mark	I/O Division	Function
1	V <sub>cc</sub>	I	Power supply terminal
2	VREF	I	Reference voltage input
3	IN4	I	Motor driver (4) input
4	IN3	I	Motor driver (3) input
5	GND	—	GND terminal
6	NC	—	Not used, connected to GND
7	NRESET	O	Reset terminal
8	GND	—	GND terminal
9	IN2	I	Motor driver (2) input
10	PC2	I	PC2 (power cut) input
11	IN1	I	Motor driver (1) input
12	PC1	I	PC1 (power cut) input (Not used, open)

Pin No.	Mark	I/O Division	Function
13	PV <sub>cc</sub> 1	I	Driver power supply (1)
14	PGND1	—	Driver GND terminal (1)
15	D1-	O	Motor driver (1) output terminal (-)
16	D1+	O	Motor driver (1) output terminal (+)
17	D2-	O	Motor driver (2) output terminal (-)
18	D2+	O	Motor driver (2) output terminal (+)
19	D3-	O	Motor driver (3) output terminal (-)
20	D3+	O	Motor driver (3) output terminal (+)
21	D4-	O	Motor driver (4) output terminal (-)
22	D4+	O	Motor driver (4) output terminal (+)
23	PGND2	—	Driver GND terminal (2)
24	PV <sub>cc</sub> 2	I	Driver power supply (2)

## • IC702 (MN66271RA): Servo processor/Digital signal processor/Digital filter/D/A converter

Pin No.	Mark	I/O Division	Function
1	BCLK	O	Serial bit clock terminal
2	LRCK	O	L/R discriminating signal
3	SRDATA	O	Serial data (Not used, open)
4	DV <sub>DD1</sub>	I	Power supply (digital circuit) terminal
5	DV <sub>SS1</sub>	—	GND (digital circuit) terminal
6	TX	O	Digital audio interface signal
7	MCLK	I	Command clock signal
8	MDATA	I	Command data signal
9	MLD	I	Command load signal ("L": LOAD)
10	SENSE	O	Sense signal (OFT, FESL, NACEND, NAJEND, POSAD, SFG)
11	/FLOCK	O	Optical servo condition (focus) ("L": lead-in)
12	/TLOCK	O	Optical servo condition (tracking) ("L": lead-in)
13	BLKCK	O	Sub-code block clock (f=75 Hz) (Not used, open)
14	SQCK	I	Sub-code Q register clock
15	SUBQ	O	Sub-code Q data
16	DMUTE	I	Muting input ("H": MUTE) (Not used, connected to GND)
17	STAT	O	Status signal (CRC, CUE, CLVS, TTSTOP, FCLV, SQCK)
18	/RST	I	Reset signal ("L": reset)
19	SMCK	O	System clock (f=4.2336 MHz) (Not used, open)
20	PMCK	O	Frequency division clock signal (Not used, open) $(f = \frac{1}{1.92} \times ck = 88.2 \text{ kHz})$
21	TRV	O	Traverse servo control

Pin No.	Mark	I/O Division	Function
22	TVD	O	Traverse drive signal
23	PC	O	Turntable motor drive signal ("L": ON)
24	ECM	O	Turntable motor drive signal (Forced mode)
25	ECS	O	Turntable motor drive signal (Servo error signal)
26	KICK	O	Kick pulse output
27	TRD	O	Tracking drive signal output
28	FOD	O	Focus drive signal output
29	VREF	I	D/A drive output (TVD, ECS, TRD, FOD, FBAL, TBAL) normal voltage input terminal
30	FBAL	O	Focus balance adj. output (Not used, open)
31	TBAL	O	Tracking balance adj. output
32	FE	I	Focus error signal (analog input)
33	TE	I	Tracking error signal (analog input)
34	RFENV	I	RF envelope signal
35	VDET	I	Oscillation det. signal ("H": det.)
36	OFT	I	Off track signal ("H": Off track)
37	TRCRS	I	Track cross signal input
38	/RFDET	I	RF detection signal ("L": detection)
39	BDO	I	Dropout detection signal ("H": dropout)
40	LDON	O	Laser power control ("H": ON)
41	TES	O	Tracking error shunt output ("H": dropout)
42	PLAY	O	Play signal ("H": play)



Pin No.	Mark	I/O Division	Function
43	WVEL	O	Double velocity status signal ("H": double)
44	ARF	I	RF signal input
45	IREF	I	Reference current input
46	DRF	I	DSL bias terminal (Not used, open)
47	DSL F	I/O	DSL loop filter terminal
48	PLL F	I/O	PLL loop filter terminal
49	VCO F	I/O	VCO loop filter terminal (Not used, open)
50	AV <sub>DD2</sub>	I	Power supply (analog circuit) terminal (2)
51	AV <sub>SS2</sub>	—	GND (analog circuit) terminal
52	EFM	O	EFM signal (Not used, open)
53	PCK	O	PLL extract clock (f=4.3218MHz)
54	PDO	O	Phase compared signal of EFM and PCK (Not used, open)
55	SUBC	O	Sub-code serial output data (Not used, open)
56	SBCK	I	Sub-code serial input clock (Not used, connected to GND)
57	V <sub>SS</sub>	—	GND terminal
58	X1	I	Crystal oscillator terminal (f=16.9344MHz)
59	X2	O	
60	V <sub>DD</sub>	I	Power supply terminal
61	BYTCK	O	Byte clock signal (Not used, open)
62	/CLDCK	O	Sub-code frame clock signal (f CLDCK=7.35kHz: Normal) (Not used, open)

Pin No.	Mark	I/O Division	Function
63	FCLK	O	Crystal frame clock (Not used, open)
64	IPFLAG	O	Interpolation flag terminal
65	FLAG	O	Flag terminal
66	CLVS	O	Turntable servo phase synch. signal ("H": CLV, "L": Rough servo) (Not used, open)
67	CRC	O	Sub-code CRC check terminal ("H": OK, "L": NG)
68	DEMPH	O	De-emphasis ON signal ("H": ON) (Not used, open)
69	RESY	O	Re-synchronizing signal of frame sync. (Not used, open)
70	/RST2	I	Reset terminal after "MASH" circuit
71	/TEST	I	Test terminal (Normal: "H")
72	AV <sub>DD1</sub>	I	Power supply (analog circuit) terminal (1)
73	OUTL	O	Lch audio signal
74	AV <sub>SS1</sub>	—	GND (analog circuit) terminal (1)
75	OUTR	O	Rch audio signal
76	RSEL	I	Polarity direction control terminal of RF signal
77	CSEL	I	Frequency control terminal of crystal oscillator (Not used, connected to GND)
78	PSEL	I	Test terminal (Normal: "L")
79	MSEL	I	"SMCK" terminal frequency select ("L": SMCK=4.2336MHz)
80	SSEL	I	"SUBQ" terminal mode select ("H": Q code buffer)

## • IC401 (ATT78043B065): System control &amp; FL drive

Pin No.	Mark	I/O Division	Function
1 5 7	G7 G1	O	Grid signal of FL display
8	VDD	I	Power supply terminal
9	MCLK	O	Command clock signal
10	MDATA	O	Command data signal
11	MLD	O	Command load signal ("L" LOAD)
12	SENSE	I	Sense signal
13	DMUTE	O	Muting control signal
14	SQCK	O	Sub-code Q register clock
15	NC	—	Not connected
16	SUBQ	I	Sub-code Q data
17	/RESET	I	Reset signal input
18	ZSENSE	—	Not used, connected to GND
19	REC. EN	I	Synchro. rec. control terminal
20	AVSS	—	GND terminal
21	/RSTSV	O	Reset signal output
22	OPEN	I	Open detect terminal
23	DIR	O	Motor control signal
24	TRUN	O	
25	LOAD	O	Motor control signal
26	DAC	O	Not used, open
27	RESTSW	I	Rest position de
28	UP/DOWN	I	Traverse deck up/down det. terminal
29	AVDD	I	Power supply terminal
30	AVREF	I	Power supply terminal
31	XT1	—	Not used, connected to GND

Pin No.	Mark	I/O Division	Function
32	XT2	—	Not used, open
33	VSS	—	GND terminal
34	X1	I	Crystal Osc terminal (F: 4.2336MHz)
35	X2	O	
36 42	KEYIN 7 KEYIN 1	I	Key return signal
43	PWM	O	Motor control signal
44	POFF	I	Power det. terminal
45	POSITION	I	Rotary tray position det. terminal
46	SPEED	I	Loading motor speed sensor signal
47	REMOCON	I	Remote control signal input
48	IC	—	Not used, connected to GND
49	/TLOCK	I	Optical servo condition (tracking) input
50	/FLOCK	I	Optical servo condition (focus) input
51	STAT	I	Status signal (CRC, CUE, CLVS, TTSTOP, FCLV, SQCK)
52	VDD	I	Power supply terminal
53	POWER	O	Power ON/OFF output terminal
54	SYNCHRO	—	Not used, open
55 60	KEYOUT 6 KEYOUT 1	O	Key scan signal
61 70	S16 S7	O	Segment signal of FL display
71	VPP	I	Power supply terminal
72 77	S6 S1	O	Segment signal of FL display
78	EXDATA	O	Not used, open
79	EXCLK	O	Not used, open
80	G8	O	Grid signal of FL display

BLOCK DIAGRAM

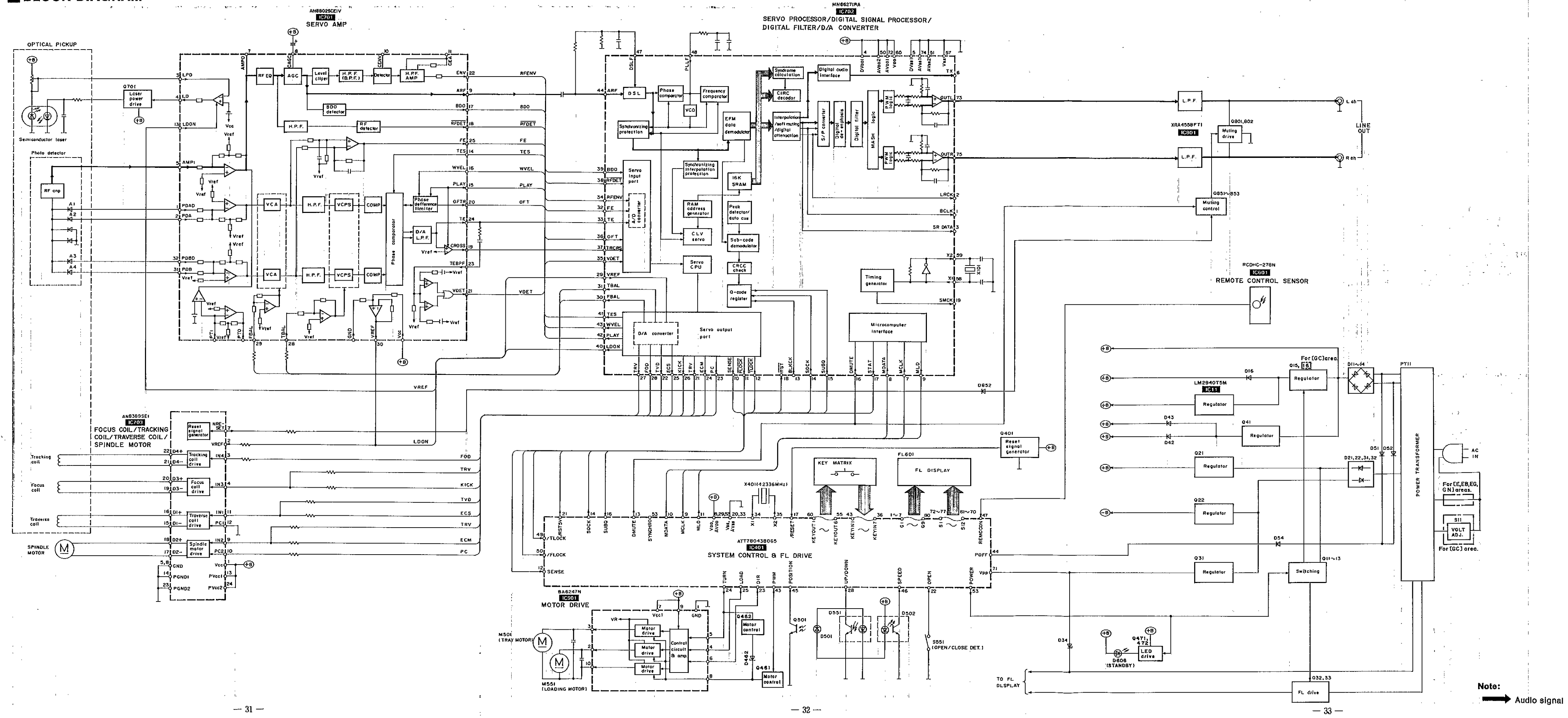

Note: Audio signal

### SCHEMATIC DIAGRAM (Parts list on pages 48~51.)

(This schematic diagram may be modified at any time with development of new technology.)

#### Note:

- S11 : Voltage adj. switch in "240V" position. [For (GC) area only.] (110V ↔ 127V ↔ 220V ↔ 240V)
- S551 : Disc tray "Open/Close" detector switch.
- S601 : Time mode (TIME MODE) switch.
- S602 : Spiral (SPIRAL) switch.
- S603 : Random mode (RANDOM MODE) switch.
- S604 : Repeat (REPEAT) switch.
- S607 : Stop (■) switch.
- S608 : Pause (■) switch.
- S609 : Play (▶) switch.
- S610~S614 : Disc (DISC 1~5) switches. [S610: 1, S611: 2, S612: 3, S613: 4, S614: 5]
- S615 : Disc skip (DISC SKIP) switch.
- S616 : Program mode (PROGRAM MODE) switch.
- S617, 618 : Search (SEARCH) switches. [S617: ◀◀, S618: ▶▶]
- S619, 620 : Skip (SKIP) switches. [S619: ◀◀, S620: ▶▶]
- S621 : Loading drawer open/close (▲ OPEN/CLOSE) switch.
- S631 : Power "STANDBY & ION" (POWER, STANDBY & ON) switch.
- S651~S662 : Numeric (1~10, 0, > 10) switches. S651: (1), S652: (2), S653: (3), S654: (4), S655: (5), S656: (6), S657: (7), S658: (8), S659: (9), S660: (10), S661: (> 10), S662: (0)

• The voltage value and waveforms are the reference voltage of this unit measured by DC electronic voltmeter (high impedance) and oscilloscope on the basis of chassis. Accordingly, there may arise some error in voltage values and waveforms depending upon the internal impedance of the tester or the measuring unit.

\* The parenthesized are the values of voltage generated during playing (Test disc 1kHz, L+R, 0dB), others are voltage values in stop mode.

• Important safety notice:  
Components identified by Δ mark have special characteristics important for safety. Furthermore, special parts which have purposes of fire-retardant (resistors), high-quality sound (capacitors), low-noise (resistors), etc. are used as occasion calls. When replacing any of components, be sure to use only manufacturer's specified parts shown in the parts list.

• The supply part number is described alone in the replacement parts.

Part No.	Production Part No.	Supply Part No.
IC11	LM2940T5M	LM2940T5

— / — : Positive voltage lines and negative voltage lines.  
— : audio signal lines.

#### Caution!

- IC and LSI are sensitive to static electricity. Secondary trouble can be prevented by taking care during repair.
- Cover the parts boxes made of plastics with aluminum foil.
- Ground the soldering iron.
- Put a conductive mat on the work table.
- Do not touch the pins of IC or LSI with fingers directly.

#### Terminal guide of IC's, transistors and diodes.

XRA4558FT1 	AN8802SCE1V 	AN8389SE1 	MN68271RA 	ATT78043B065 	BA6247N 
LM2940T5M 	2SA1309AIQST 2SC3311AIQST 2SD1450RSTTA UN4112TA UN4114TA UN4212TA UN4214TA UN4215TA 	2SD2037EFTA 	2SB1238QSTV6 2SD1862QRTV6 	PT381 Cathode Anode 	
2SB709S 	MA4051MTA MA4062MTA MA4068HTA MA4091MTA MA4056MTA Cathode Anode 	MA4100MTA MA4270MTA Cathode Anode 	RL1N4003N02 Cathode Anode 	MA165TA 1SS291TA Cathode Anode 	
GL380 Anode Cathode 	RCDHC-278N 	RSQGP1553V Cathode Anode 	SG-206S Cathode Anode 	LN018304P Anode Cathode 	

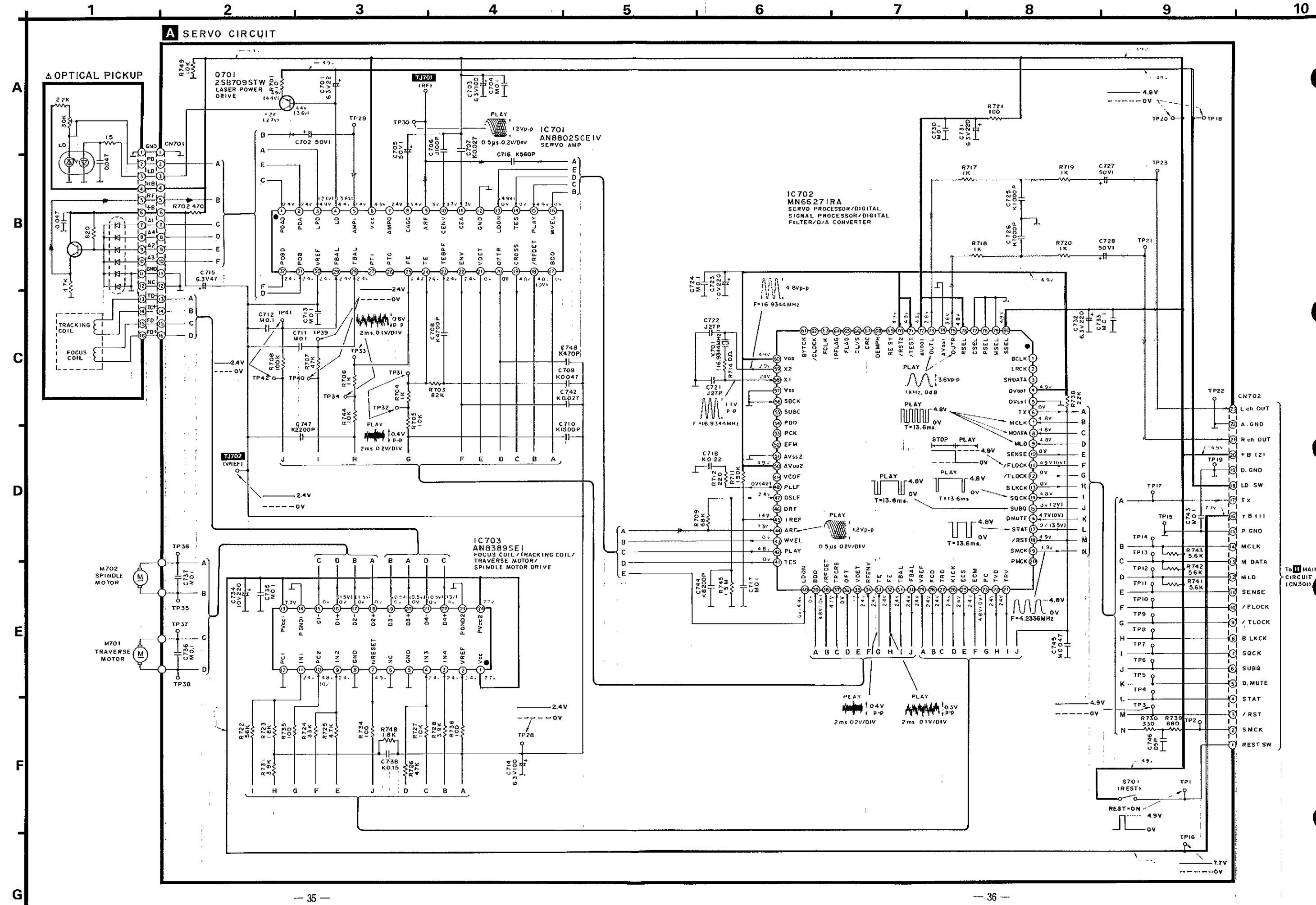

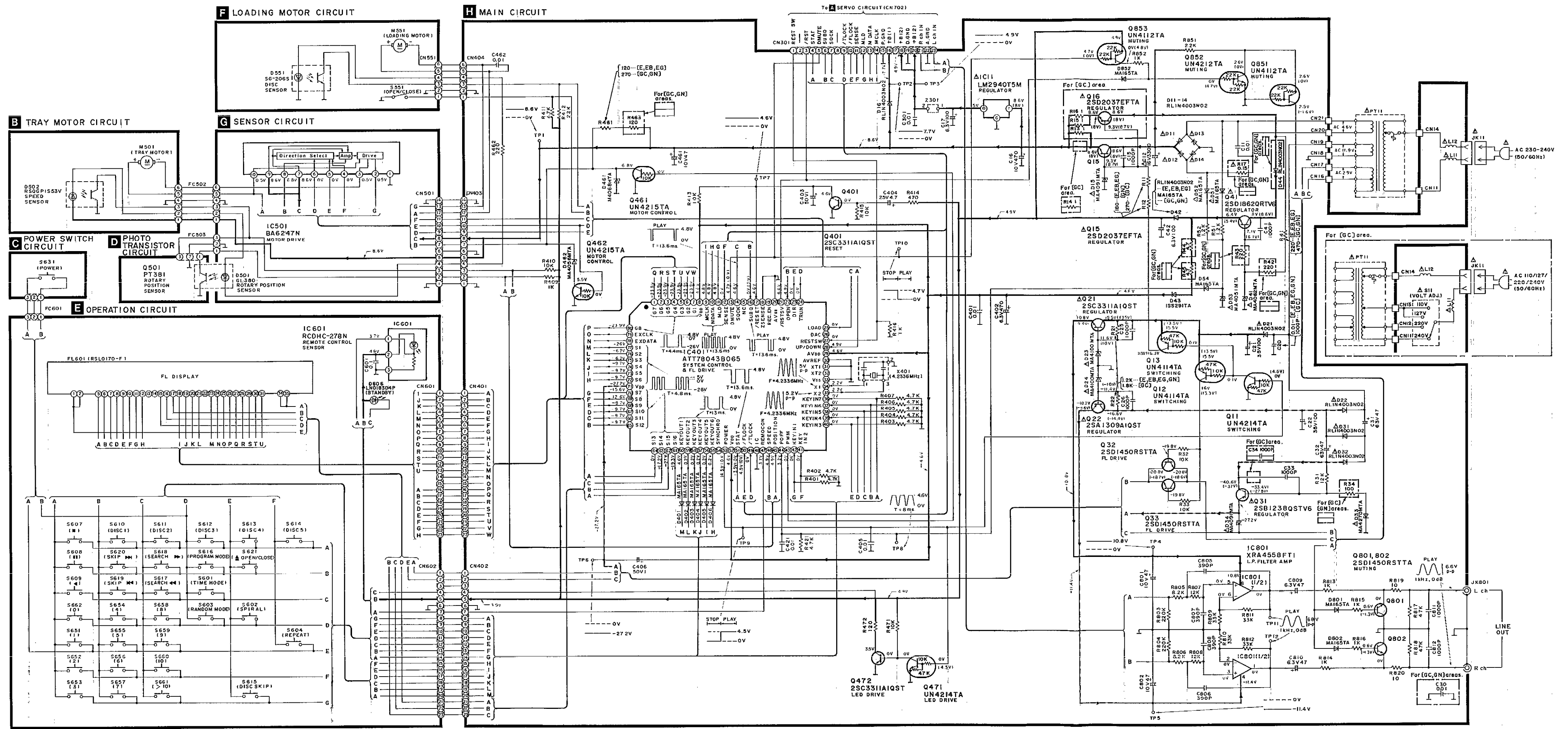

# PRINTED CIRCUIT BOARDS

(This printed circuit board diagram may be modified at any time with the development of new technology)

**H** MAIN P.C.B. (REP1722B-M... (E, EB, EG)  
REP1722C-M... (GN)  
REP1722D-M... (GC)

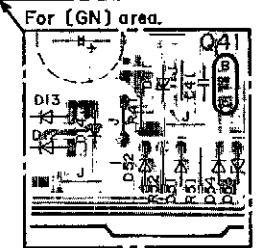
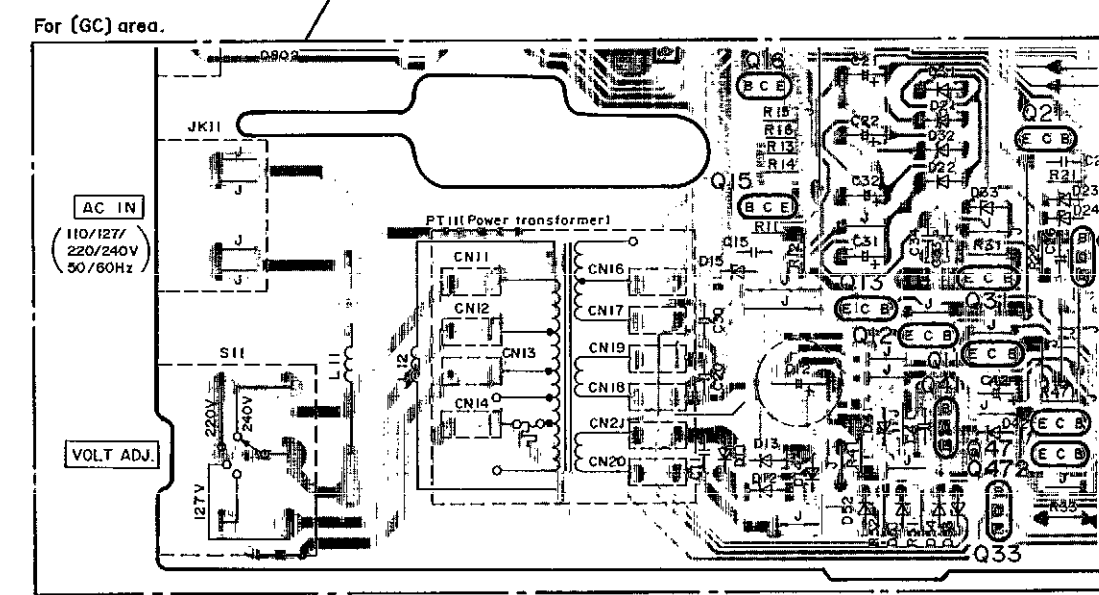
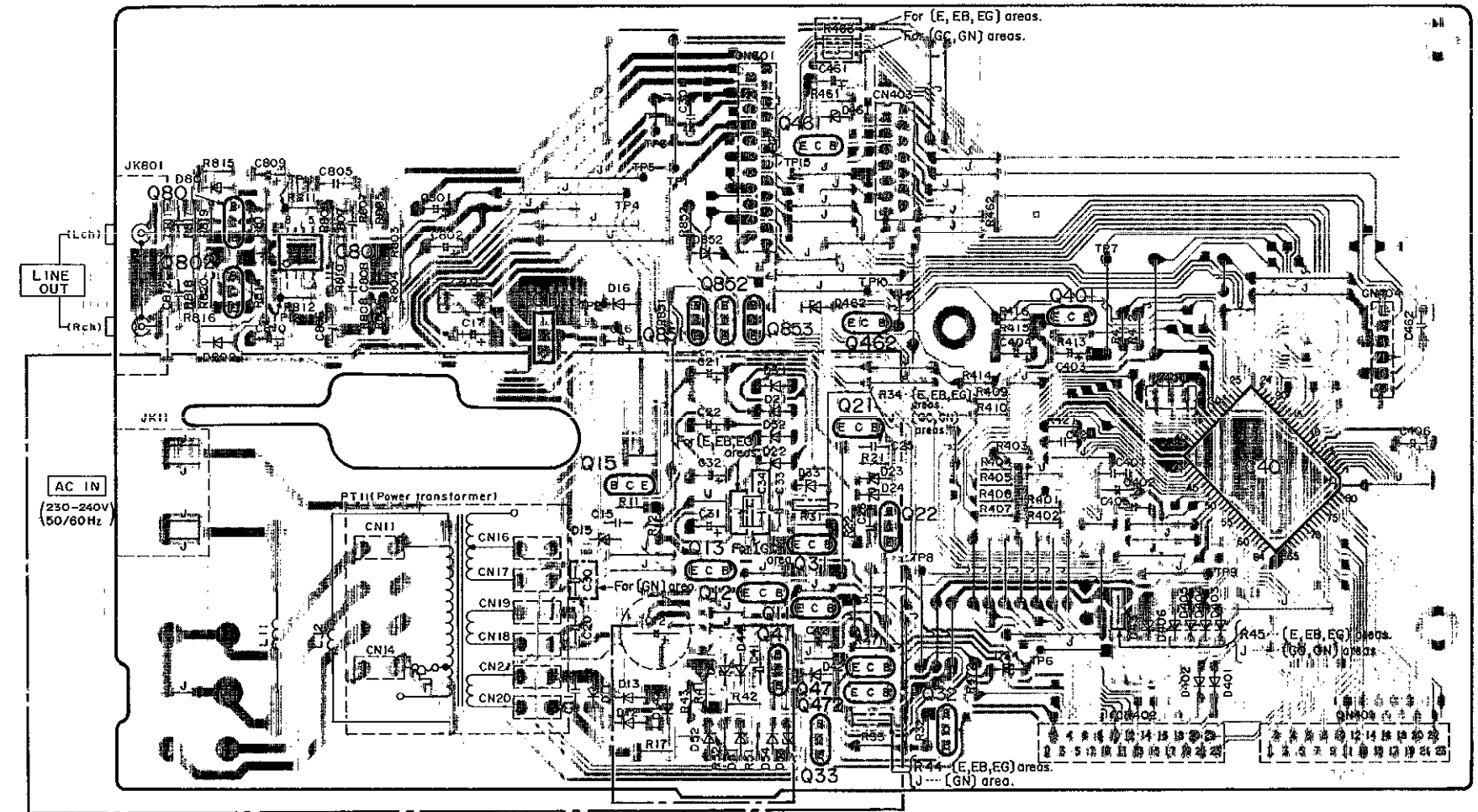

**A** SERVO P.C.B. (REP1650A-N)

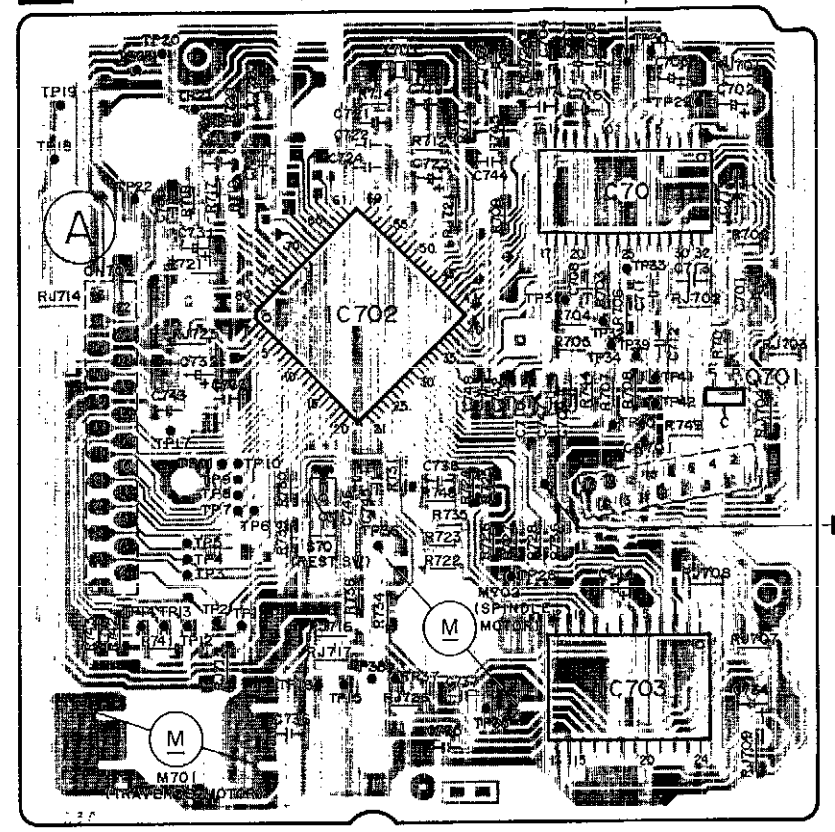

**C** POWER SWITCH P.C.B. (REP1723C-S)

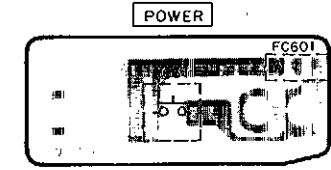

**E** OPERATION P.C.B. (REP1723C-S)

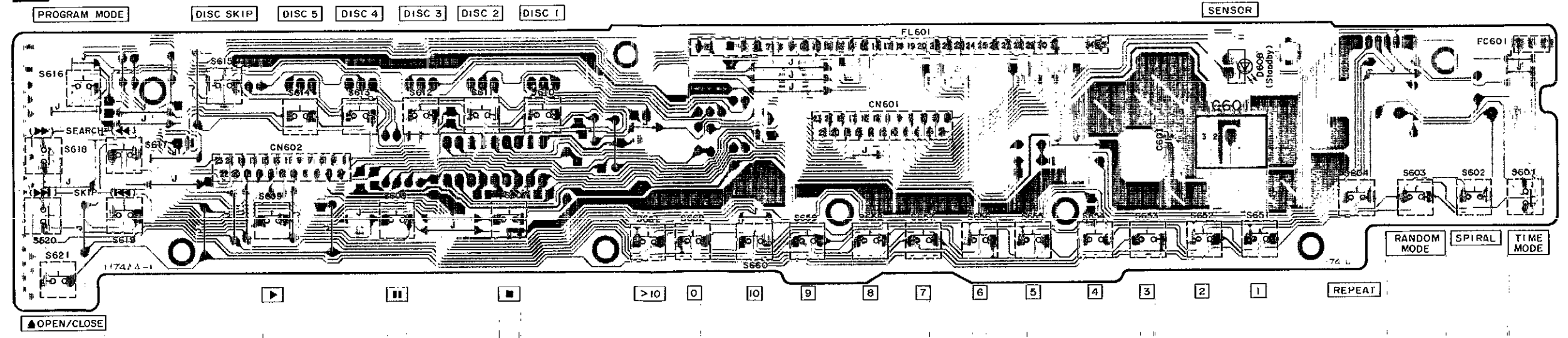

**F** LOADING MOTOR P.C.B. (REP1724A-N)

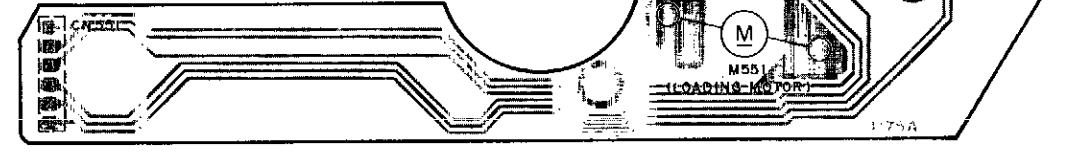

**B** TRAY MOTOR P.C.B. (REP1725A-N)

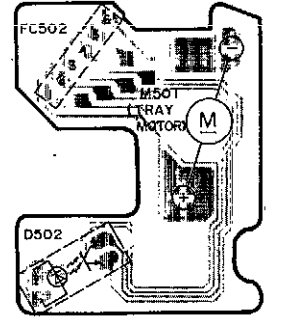

**D** PHOTO TRANSISTOR P.C.B. (REP1725A-N)

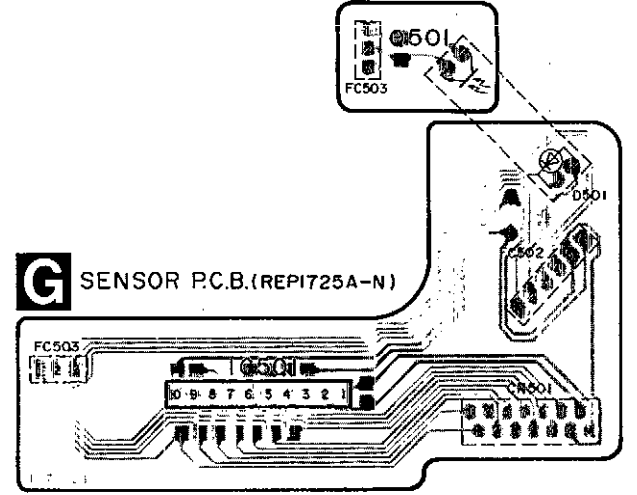

**G** SENSOR P.C.B. (REP1725A-N)

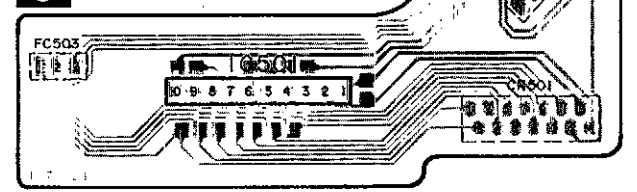



# WIRING CONNECTION DIAGRAM

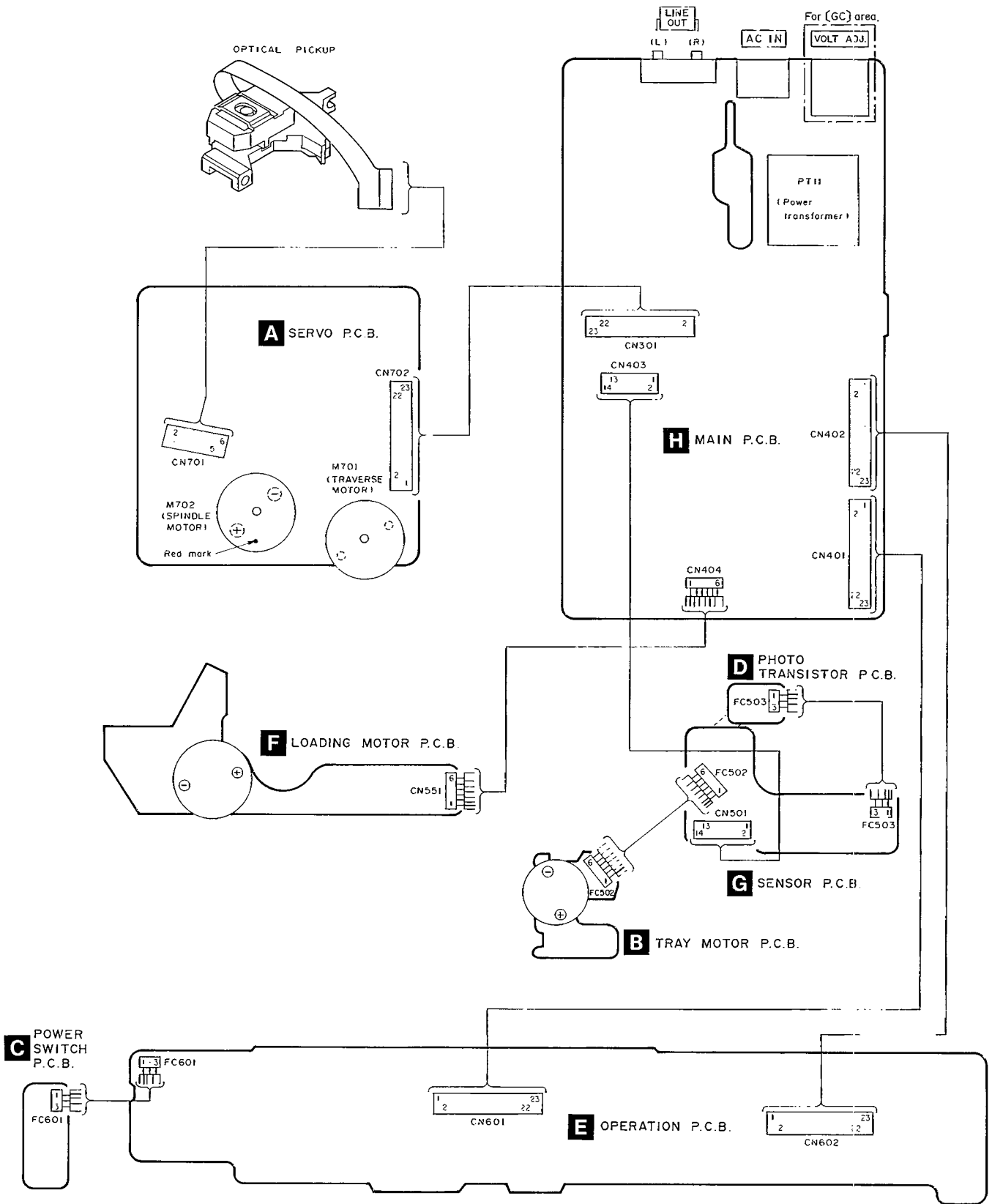

## REPLACEMENT PARTS LIST

Ref. No.	Part No.	Part Name & Description	Remarks	Ref. No.	Part No.	Part Name & Description	Remarks
		CABINET AND CHASSIS		42	RMG0200	STOPPER TUBE	
1	RKMD193-K	CABINET		43	XTB26+8J	SCREW	
2	SNE2129-3	SCREW		44	XTB3+10JFZ	SCREW	
3	XTBS3+8JFZ1	SCREW		45	XTB3+20J	SCREW	
4	RDG0267	REDUCTION GEAR		46	XTB3+8JFZ	SCREW	
5	RDG0268	CLOSE LOCK GEAR				LOADING MECHANISM	
6	RDG0269	OPEN LOCK GEAR		101	RDG0270	REDUCTION GEAR	
7	RDV0031	BELT		102	RDG0271	DRIVE GEAR (1)	
8	RFKPLPD667PA	TRAY MOTOR (M501) ASS' Y		103	RDG0272	DRIVE GEAR (2)	
9	RMN0254	LED HOLDER (D501, Q501)		104	RDK0025	DRIVE CAM	
10	RMN0255	SENSOR HOLDER (D502)		105	RDPO050	PULLEY GEAR	
11	RMN0263	MOTOR HOLDER		106	RFKPLPD667PB	LOADING MOTOR (M551) ASS' Y	
12	REZ0648	FPC BOARD (14P)		107	RHD26019	SCREW	
13	RFKNLPD667PA	TRAY ASS' Y		108	RMG0268-K	BELT	
13-1	RMF0182	TRAY FELT		109	RML0334	DRIVE LEVER	
13-2	RMG0200	SILENT RUBBER		110	RMM0117	SLIDE PLATE (1)	
13-3	RMRO546-W	TRAY ROLLER		111	RMM0118	SLIDE PLATE (2)	
14	RGTO019	ROTARY TRAY		112	RMRO746-W	REINFORCING PLATE	
15	RHW81001-1	WASHER		113	RFKNLPD667PB	MECHANISM BASE ASS' Y	
16	RMBO365	SPRING		114	RXQ0346	SLIDER ASS' Y	
17	RME0152	LOCK GEAR SPRING		115	XTB3+10JFZ	SCREW	
18	RMS0123-1	RIVET		116	RAE0113Z	TRAVERSE DECK ASS' Y	
19	XTB3+10G	SCREW		116-1	SHGD112	FLOATING RUBBER (1)	
20	XTWS3+10T	SCREW		116-2	SHGD113-1	FLOATING RUBBER (2)	
21	XWE3D13	WASHER		116-3	XQS17+A35FZ	SCREW	
22	REZ0623	FLAT CABLE (6P)		117	RME0109	FLOATING SPRING (1)	
23	REZ0635	FLAT CABLE (23P)		118	RME0142	FLOATING SPRING (2)	
24	REZ0636	FLAT CABLE (23P)		119	RMRO698-K	TRAVERSE CHASSIS	
25	REZ0637	FPC BOARD (23P)		120	RMS0123-1	TRAVERSE FIXED PIN (1)	
26	RFKHLPD667E	REAR PANEL ASS' Y	(E, EG)	121	RMS0350	TRAVERSE FIXED PIN (2)	
26	RFKHLPD667EB	REAR PANEL ASS' Y	(EB, GN)	122	XTV2+6G	SCREW	
26	RFKHLPD667GC	REAR PANEL ASS' Y	(GC)	123	RMX0094	TRAY HOLDER	
27	RFKJLPD667PK	CHASSIS ASS' Y					
27-1	RKA0053-A	FOOT					
28	RMRO749-W	CABLE HOLDER					
29	RMRO742-K	TRAY BASE GUIDE (L)					
30	RMRO743-K	TRAY BASE GUIDE (R)					
31	RMRO765-W	TRANSFORMER BASE					
32	RHM245ZA	MAGNET					
33	RMRO334	FIXED PLATE					
34	RFKNLPD667E	CLAMP PLATE ASS' Y	(E)				
34	RFKNLPD667EB	CLAMP PLATE ASS' Y	(EB, EG, GC, GN)				
35	RMRO761-W	CLAMPER					
36	RMN0185-1	FL HOLDER					
37	RFKGLPD667EK	FRONT PANEL ASS' Y					
37-1	RGK0611A-K	FRONT ORNAMENT PLATE					
38	RGU1016-K	MAIN BUTTON					
39	RGU1019-K	10 KEY BUTTON					
40	RGU1015-K	POWER BUTTON					
41	RGU1017-K	SUB BUTTON					



**■ CABINET PARTS LOCATION**

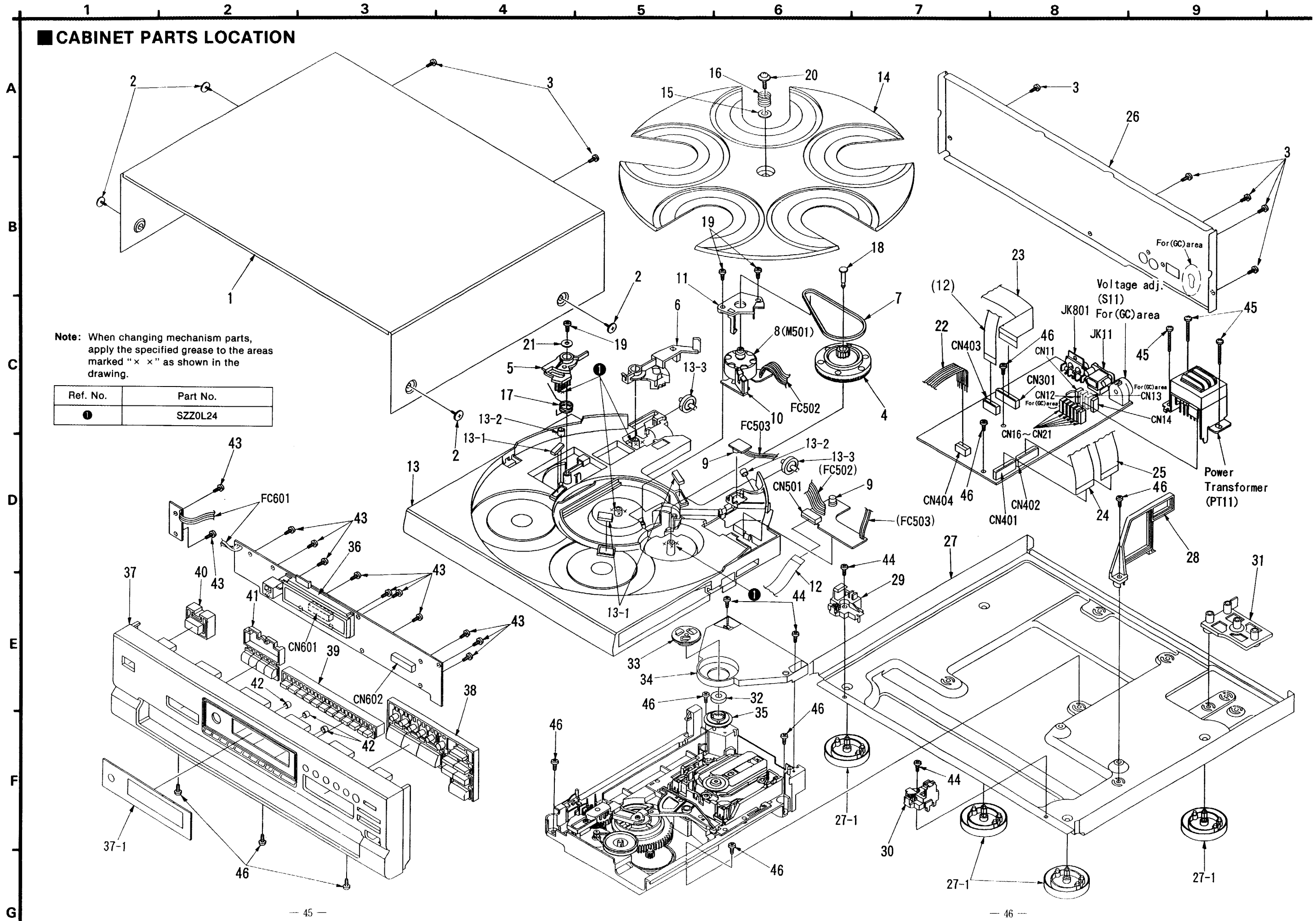

**Note:** When changing mechanism parts, apply the specified grease to the areas marked "x x" as shown in the drawing.

Ref. No.	Part No.
①	SZZ0L24

LOADING MECHANISM PARTS

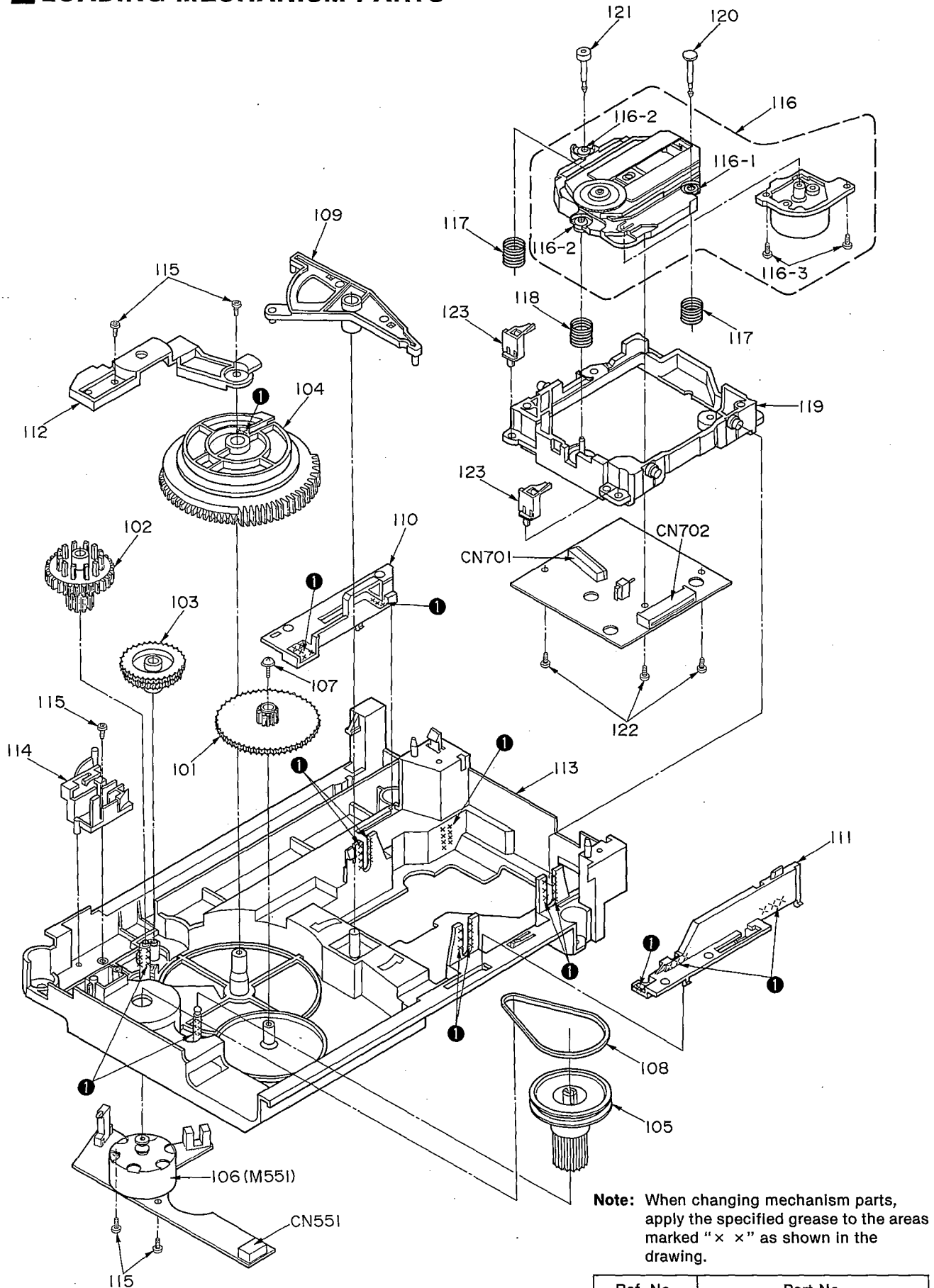

Note: When changing mechanism parts, apply the specified grease to the areas marked "x" as shown in the drawing.

Ref. No.	Part No.
①	SZZ0L24

REPLACEMENT PARTS LIST

Notes: \*Important safety notice:  
 Components identified by Δ mark have special characteristics important for safety. Furthermore, special parts which have purposes of fire-retardant (resistors), high-quality sound (capacitors), low-noise (resistors), etc. are used. When replacing any of components, be sure to use only manufacturer's specified parts shown in the parts list.  
 \*The parenthesized indications in the Remarks columns specify the areas. (Refer to the cover page for area.)  
 Parts without these indications can be used for all areas.  
 \*Warning: This product uses a laser diode. Refer to caution statements on page 2.  
 \*ACHTUNG: Die Lasereinheit nicht zerlegen.  
 Die Lasereinheit darf nur gegen eine vom Hersteller spezifizierte Einheit ausgetauscht werden.  
 \*The "(SF)" mark denotes the standard part.

Ref. No.	Part No.	Part Name & Description	Remarks	Ref. No.	Part No.	Part Name & Description	Remarks
				D51, 52	MA165	DIODE	Δ
		INTEGRATED CIRCUIT(S)		D53	MA4051MTA	DIODE	
				D54	MA165	DIODE	
IC11	LM2940T5	REGULATOR	Δ	D401-406	MA165	DIODE	
IC401	ATT78043B065	SYSTEM CONTROL&FL DRIVE		D461	MA4068HTA	DIODE	
IC501	BA6247N	MOTOR DRIVE		D462	MA4056MTA	DIODE	
IC601	RC4HC-278N	REMOTE CONTROL SENSOR		D501	GL380TB	L. E. D.	
IC801	XRA4558FT1	L. P. F.		D502	RSQGP1S53V	DIODE	
		TRANSISTOR(S)		D551	SG-206S	DIODE	
Q11	UN4214TA	TRANSISTOR		D606	LN018304P	L. E. D.	
Q12, 13	UN4114TA	TRANSISTOR		D801, 802	MA165	DIODE	
Q15	2SD2037EFTA	TRANSISTOR	Δ	D852	MA165	DIODE	
Q16	2SD2037EFTA	TRANSISTOR	(GC) Δ			COIL(S)	
Q21	2SC3311AIQST	TRANSISTOR	Δ	L11, 12	RLQX400MT-D	COIL	Δ
Q22	2SA1309AIQST	TRANSISTOR	Δ			TRANSFORMER(S)	
Q31	2SB1238QSTV6	TRANSISTOR	Δ				
Q32, 33	2SD1450RTA	TRANSISTOR		PT11	RTP1K4B017-X	POWER TRANSFORMER	(E, EB, EG, GN) Δ
Q41	2SD1862QRV6	TRANSISTOR	Δ	PT11	RTP1K4E025-X	POWER TRANSFORMER	(GC) Δ
Q401	2SC3311AIQST	TRANSISTOR				COMPONENT COMBINATION(S)	
Q461, 462	UN4215	TRANSISTOR		Z301	BL02RN2R65T2	COMBINATION PART	
Q471	UN4214TA	TRANSISTOR				OSCILLATOR(S)	
Q472	2SC3311AIQST	TRANSISTOR		X401	RSXY4M23M01T	OSCILLATOR (4.2336MHz)	
Q501	PT381TB	TRANSISTOR				DISPLAY TUBE(S)	
Q801, 802	2SD1450RTA	TRANSISTOR		FL601	RSL0170-F	DISPLAY TUBE	
Q851	UN4112	TRANSISTOR				SWITCH(ES)	
Q852	UN4212TA	TRANSISTOR		S11	RSR4A003S-H	VOLTAGE ADJ.	(GC) Δ
Q853	UN4112	TRANSISTOR		S551	RSH1A005	OPEN/CLOSE DETECTOR	
		DIODE(S)		S601	EVQ21405R	TIME MODE	
D11-14	RL1N4003N02	DIODE	Δ	S602	EVQ21405R	SPIRAL	
D15	MA4091-M	DIODE	Δ	S603	EVQ21405R	RANDOM MODE	
D16	RL1N4003N02	DIODE		S604	EVQ21405R	REPEAT	
D21, 22	RL1N4003N02	DIODE	Δ	S607	EVQ21405R	STOP	
D23, 24	MA4100MTA	DIODE	Δ	S608	EVQ21405R	PAUSE	
D31, 32	RL1N4003N02	DIODE	Δ	S609	EVQ21405R	PLAY	
D33	MA4270	DIODE	Δ				
D34	MA4091-M	DIODE	Δ				
D41	MA4062MTA	DIODE					
D42	RL1N4003N02	DIODE	(E, EB, EG)				
D42	MA165	DIODE	(GC, GN)				
D43	1SS291TA	DIODE					
D44	RL1N4003N02	DIODE	(E, EB, EG)				

Ref. No.	Part No.	Part Name & Description	Remarks	Ref. No.	Part No.	Part Name & Description	Remarks
S610	EVQ21405R	DISC 1				SERVO P. C. B.	
S611	EVQ21405R	DISC 2				INTEGRATED CIRCUIT(S)	
S612	EVQ21405R	DISC 3					
S613	EVQ21405R	DISC 4		IC701	AN8802SCE1V	SERVO AMP	
S614	EVQ21405R	DISC 5		IC702	MN66271RA	SERVO PROCESSOR	
S615	EVQ21405R	DISC SKIP		IC703	AN8389SE1	MOTOR DRIVE	
S616	EVQ21405R	PROGRAM MODE					
S617	EVQ21405R	R. SEARCH				TRANSISTOR(S)	
S618	EVQ21405R	F. SEARCH					
S619	EVQ21405R	R. SKIP		Q701	2SB709S	TRANSISTOR	
S620	EVQ21405R	F. SKIP					
S621	EVQ21405R	OPEN/CLOSE				OSCILLATOR(S)	
S631	EVQ21405R	POWER					
S651	EVQ21405R	NUMERIC 1		X701	RSX716M9M02T	OSCILLATOR (16.9344MHz)	
S652	EVQ21405R	NUMERIC 2					
S653	EVQ21405R	NUMERIC 3				SWITCH(ES)	
S654	EVQ21405R	NUMERIC 4					
S655	EVQ21405R	NUMERIC 5		S701	BSM0006-P	REST DETECTOR	
S656	EVQ21405R	NUMERIC 6					
S657	EVQ21405R	NUMERIC 7				CONNECTOR(S) AND SOCKET(S)	
S658	EVQ21405R	NUMERIC 8					
S659	EVQ21405R	NUMERIC 9		CN701	RJU035T016-1	SOCKET (16P)	
S660	EVQ21405R	NUMERIC 10		CN702	RJS1A6723-1Q	CONNECTOR (23P)	
S661	EVQ21405R	NUMERIC >10					
S662	EVQ21405R	NUMERIC 0				PACKING MATERIAL	
		CONNECTOR(S) AND SOCKET(S)		P1	RPG1993	PACKING CASE	(E, EC, GC)
				P1	RPG1992	PACKING CASE	(EB)
				P1	RPG1996	PACKING CASE	(GN)
CN11	RJS1A1101T1	CONNECTOR (1P)		P2	RPN0760	CUSHION	(E, EC, GC)
CN12, 13	RJS1A1101T1	CONNECTOR (1P)	(GC)	P2	RPN0772	CUSHION	(EB, CN)
CN14	RJS1A1101T1	CONNECTOR (1P)		P3	XZB60X65A01Z	PROTECTION BAG (UNIT)	
CN16-21	RJS1A1101T1	CONNECTOR (1P)					
CN301	RJS1A6823	CONNECTOR (23P)				ACCESSORIES	
CN401, 402	RJS1A6823	CONNECTOR (23P)		A1	RFKSLPD667E	INSTRUCTION MANUAL ASS'Y	(E)
CN403	RJS1A6814	CONNECTOR (14P)		A1	RQT2321-B	INSTRUCTION MANUAL	(EB, GN)
CN404	RJS1A6606	CONNECTOR (6P)		A1	RQT2432-D	INSTRUCTION MANUAL	(EG)
CN501	RJS1A6714	CONNECTOR (14P)		A1	RFKSLPD667GC	INSTRUCTION MANUAL ASS'Y	(GC)
CN551	RJS2A1506	CONNECTOR (6P)		A2	RQA0013	WARRANTY CARD	(E, EB, EG)
CN601, 602	RJS1A6223-1	CONNECTOR (23P)		A2	RQX74337A	WARRANTY CARD	(GN)
		JACK(S)		A3	RQCB0169	SERVICENTER LIST	
				A4	RJA0019-2K	AC POWER SUPPLY CORD	(E, EG, GC) △ (SF)
JK11	SJS9236	AC INLET	(E, EB, EG, GC) △	A4	VJA0733	AC POWER SUPPLY CORD	(EB) △ (SF)
JK11	SJSD16	AC INLET	(GN) △	A4	RJA0036-K	AC POWER SUPPLY CORD	(GN) △ (SF)
JK801	RJH3201N	LINE OUT		A5	SJP2249-3	STEREO CONNECTION CABLE	
				A6	RQLA0134	VOLTAGE CAUTION LABEL	(GC)
		FLAT CABLE(S)		A7	SJP5213-1	POWER PLUG ADAPTOR	(GC) △
FC502	REZ0612	FLAT CABLE (6P)					
FC503	REZ0613	FLAT CABLE (3P)					
FC601	REZ0610	FLAT CABLE (3P)					

## RESISTORS AND CAPACITORS

Notes : \* Capacity values are in microfarads (uF) unless specified otherwise, P=Pico-farads (pF) F=Farads (F)  
\* Resistance values are in ohms, unless specified otherwise, 1K=1,000 (OHM), 1M=1,000k (OHM)

Ref. No.	Part No.	Values & Remarks	Ref. No.	Part No.	Values & Remarks	Ref. No.	Part No.	Values & Remarks
		RESISTORS	C20	ECBT1E103ZF	25V 0.01U E, EB, EG, GN	R730	ERJ6GEYJ331V	1/10W 330
R11, 12	ERDS2TJ181T	1/4W 180 E, EB, EG, GN	C20	ECBT1H102KB5	50V 1000P GC	R731	ERJ6GEYJ392V	1/10W 3.9K
R11, 12	ERDS2TJ271	1/4W 270 GC	C21, 22	ECA1VM101B	35V 100U	R734-736	ERJ6GEYJ101V	1/10W 100
R13-16	ERDS2TJ1R0	1/4W 1 GC	C25, 26	ECBT1H102KB5	50V 1000P	R738	ERJ6GEYJ223V	1/10W 22K
R17	ERQL6NKR15E	1W 0.15 E, EB, EG Δ	C30	ECBT1E103ZF	25V 0.01U GC, GN	R739	ERJ6GEYJ681V	1/10W 680
R21, 22	ERDS2TJ122	1/4W 1.2K E, EB, EG, GN	C31, 32	ECA1JM470B	63V 47U	R741-743	ERJ6GEYJ562V	1/10W 5.6K
R21, 22	ERDS2TJ182	1/4W 1.8K GC	C33	ECBT1H102KB5	50V 1000P	R744	ERJ6GEYJ103V	1/10W 10K
R31	ERDS2TJ123	1/4W 12K	C34	ECBT1H102KB5	50V 1000P GC	R745	ERJ6GEYJ155V	1/10W 1.5M
R32, 33	ERDS2TJ103	1/4W 10K	C41	ECBT1H102KB5	50V 1000P	R748	ERJ6GEYJ182V	1/10W 1.8K
R34	ERDS2TJ101	1/4W 100 E, EB, EG	C42	ECEAOJKA101B	6.3V 100U	R749	ERJ8GEYJ103V	1/8W 10K
R41	ERDS2TJ471	1/4W 470 GC, GN	C301	ECBT1C103NS5	16V 0.01U			CHIP JUMPERS
R41-43	ERDS2TJ221	1/4W 220 E, EB, EG	C401	ECBT1C103NS5	16V 0.01U	R714	ERJ6GEYOR00A	CHIP JUMPER
R44, 45	ERDS2TJ4R7T	1/4W 4.7 E, EB, EG	C402	ECAOJM471B	6.3V 470U	RJ701-704	ERJ8GEYOR00A	CHIP JUMPER
R51, 52	ERDS2TJ122	1/4W 1.2K	C403	ECEA1HKA010B	50V 1U	RJ707-709	ERJ8GEYOR00A	CHIP JUMPER
R401-407	ERDS2TJ472	1/4W 4.7K	C404	ECEA1EKA4R7B	25V 4.7U	RJ714-717	ERJ8GEYOR00A	CHIP JUMPER
R409	ERDS2TJ102	1/4W 1K	C405	ECBT1C103NS5	16V 0.01U	RJ721	ERJ6GEYOR00A	CHIP JUMPER
R410	ERDS2TJ103	1/4W 10K	C406	ECEA1HKA010B	50V 1U	RJ724-726	ERJ6GEYOR00A	CHIP JUMPER
R411	ERDS2TJ472	1/4W 4.7K	C421	ECBT1C103NS5	16V 0.01U			CAPACITORS
R412	ERDS2TJ223	1/4W 22K	C461	ECEA1AKA470B	10V 47U	C701	ECEAOJKA220	6.3V 22U
R413	ERDS2TJ103	1/4W 10K	C462	ECBT1C103NS5	16V 0.01U	C702	ECEA1HKA010I	50V 1U
R414	ERDS2TJ471	1/4W 470	C601	ECFR1E104ZF5	25V 0.1U	C703	ECEAOJKA101I	6.3V 100U
R415	ERDS2TJ103	1/4W 10K	C801, 802	ECEA1AKA470B	10V 47U	C704	ECUZ1E104MBN	25V 0.1U
R416	ERDS2TJ102	1/4W 1K	C805-808	ECCRH391J5	50V 390P	C705	ECEA1HKA010I	50V 1U
R421	ERDS2TJ472	1/4W 4.7K	C809, 810	ECEAOJKA470B	6.3V 47U	C706	ECUE1H101JCN	50V 100P
R461	ERDS2EJ121	1/4W 120 E, EB, EG	C811, 812	ECBT1H102KB5	50V 1000P	C707	ECUV1E273KBN	25V 0.027U
R461	ERDS2TJ271	1/4W 270 GC, GN			<SERVO P. C. B. >	C708	ECUE1H472KBN	50V 4700P
R462	ERDS2TJ221	1/4W 220			RESISTORS	C709	ECUE1C473KBN	16V 0.047U
R463	ERDS2EJ121	1/4W 120 E, EB, EG	R701	ERJ6GEYJ100	1/10W 10	C710	ECUE1H152KBN	50V 1500P
R471	ERDS2TJ103	1/4W 10K	R702	ERJ6GEYJ471V	1/10W 470	C711, 712	ECUZ1E104MBN	25V 0.1U
R472	ERDS2EJ121	1/4W 120	R703	ERJ6GEYJ823	1/10W 82K	C713	ECUV1C104MBM	16V 0.1U
R803, 804	ERDS2TJ224T	1/4W 220K	R704	ERJ6GEYJ102A	1/10W 1K	C714	ECEAOJKA101I	6.3V 100U
R805, 806	ERDS2TJ822	1/4W 8.2K	R705	ERJ6GEYJ103V	1/10W 10K	C715	ECEAOJKA470I	6.3V 47U
R807, 808	ERDS2TJ123	1/4W 12K	R706	ERJ6GEYJ102A	1/10W 1K	C716	ECUE1H561KBN	50V 560P
R809-812	ERDS2TJ333	1/4W 33K	R707	ERJ6GEYJ473V	1/10W 47K	C717	ECUZ1E104MBN	25V 0.1U
R813-816	ERDS2TJ102	1/4W 1K	R708	ERJ6GEYJ104V	1/10W 100K	C718	ECUV1C224KBM	16V 0.22U
R817, 818	ERDS2TJ473	1/4W 47K	R709	ERJ6GEYJ683V	1/10W 68K	C721, 722	ECUE1H270JCN	50V 27P
R819, 820	ERDS2TJ100	1/4W 10	R711	ERJ6GEYJ154V	1/10W 150K	C723	ECEA1AKA221I	10V 220U
R851	ERDS2TJ222	1/4W 2.2K	R712	ERJ6GEYJ221V	1/10W 220	C724	ECUV1C104MBM	16V 0.1U
R852	ERDS2TJ102	1/4W 1K	R717-720	ERJ6GEYJ102A	1/10W 1K	C725, 726	ECUE1H102KBN	50V 1000P
		CAPACITORS	R721	ERJ6GEYJ101V	1/10W 100	C727, 728	ECEA1HPK010I	50V 1U
C11	ECBT1E103ZF	25V 0.01U	R722	ERJ6GEYJ563V	1/10W 56K	C730	ECUZ1E104MBN	25V 0.1U
C12	ECEA1CU332B	16V 3300U Δ	R723	ERJ6GEYJ182V	1/10W 1.8K	C731, 732	ECEAOJK221I	6.3V 220U
C15	ECBT1H102KB5	50V 1000P	R724	ERJ6GEYJ333V	1/10W 33K	C733	ECUZ1E104MBN	25V 0.1U
C16	ECA1AM471B	10V 470U	R725	ERJ6GEYJ472V	1/10W 4.7K	C734	ECEA1AKA221I	10V 220U
C17	ECEAOJKA101B	6.3V 100U	R726	ERJ6GEYJ473V	1/10W 47K	C735	ECUZNE104MBN	25V 0.1U
			R727	ERJ6GEYJ103V	1/10W 10K			
			R728	ERJ6GEYJ392V	1/10W 3.9K			

Ref. No.	Part No.	Values & Remarks						
C736	ECUZ1E104MBN	25V 0.1U						
C737	ECUZNE104MBN	25V 0.1U						
C738	ECUV1C154KBN	16V 0.15U						
C742	ECUV1E273KBN	25V 0.027U						
C743	ECUZ1E104MBN	25V 0.1U						
C744	ECUE1E822KBN	25V 8200P						
C745	ECUE1C473MBN	16V 0.047U						
C746	ECUE1H050DCN	50V 5P						
C747	ECUE1H222KBN	50V 2200P						
C748	ECUV1H471KBM	50V 470P						

**PACKAGING**

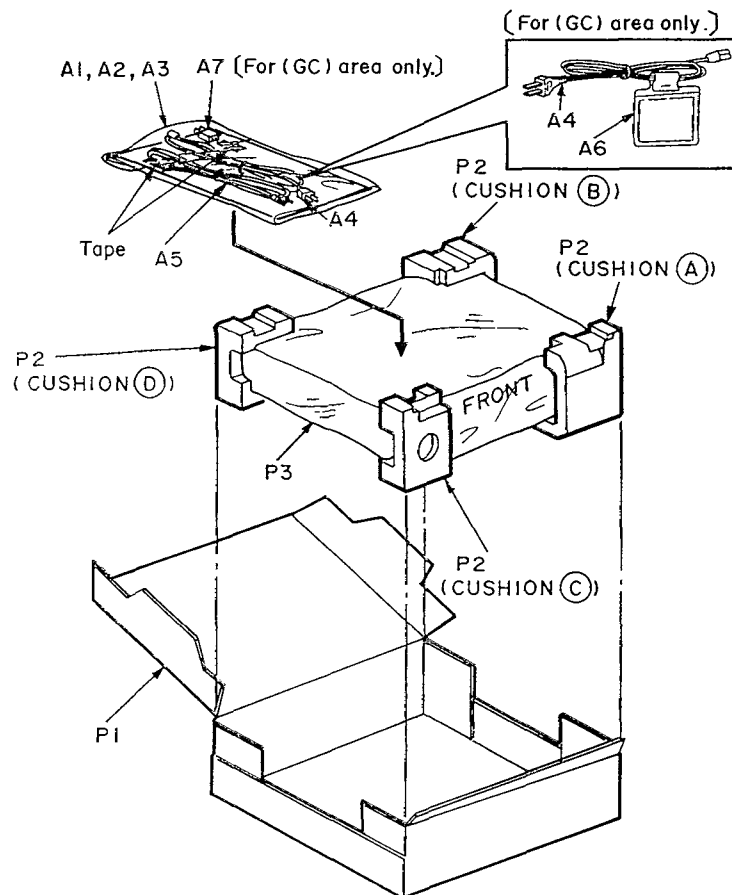

( CUSHION (A, B, C, D)  
 Part No. RPN0760 : For (E, EG, GC) areas.  
 Part No. RPN0772 : For (EB, GN) areas. )

1033