

Service Manual

Compact Disc Player

Compact Disc Player

COMPACT
disc
DIGITAL AUDIO

DIGITAL

SL-PG360A

MASH
multi-stage noise shaping

Colour

(K) Black Type

Area

Suffix for Model No.	Area	Colour
(E)	Europe	(K)
(EB)	Great Britain	
(EG)	Germany and Italy	

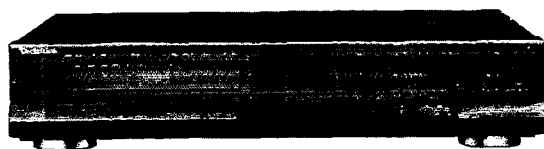

New Traverse Deck (RAE1100Z) Specifications

■ Audio

No. of channels	2 (left and right, stereo)
Frequency response	2–20,000 Hz, ± 0.5 dB
Output voltage	2 V (at 0 dB)
Dynamic range	96 dB
S/N	100 dB
Harmonic distortion	0.0035% (1 kHz, 0 dB)
Total harmonic distortion	0.004% (1 kHz, 0 dB)
Wow and flutter	Below measurable limit
DA converter	MASH (1 bit)
Output impedance	600 Ω
Load impedance	More than 10 k Ω

■ Pickup

Wavelength	780 nm
Laser Power	No hazardous radiation is emitted (with safety protection)

■ General

Power consumption	13 W
Power supply	AC 50/60 Hz, 230–240 V
Dimensions (W×H×D)	430×92×283 mm
Weight	3.3 kg

Note:

Specifications are subject to change without notice.
Weight and dimensions are approximate.

For United Kingdom only:

This apparatus was produced to BS 800.

- Technics (or Panasonic) developed the world's first MASH type DAC and ADC. MASH technology was invented by NTT (LSI Labs).
- MASH is a trademark of NTT.

Technics

■Contents

	Page		Page
●Handling Precautions for Traverse Deck	2	●Schematic Diagram	17~22
●Precaution of Laser Diode	2, 3	●Printed Circuit Board Diagram	23~25
●Accessories	3	●Wiring Connection Diagram	26
●Connections	3	●Display Function of	
●Caution for AC Mains Lead (For United Kingdom)	4	Automatically-Adjusted Results	27
●Location of Controls	5	●Digital Servo System	28
●Basic Operating Procedure	6	●Troubleshooting Guide	29, 30
●Disassembly Instructions	7~12	●Functions of IC Terminals	31~33
●Installing Disc Tray	13	●Replacement Parts List	34~40
●How to Check the Main P.C.B.	14	●Cabinet Parts Location	37
●How to Check the Servo P.C.B.	14	●Loading Unit Parts Location	39
●Block Diagram	15, 16	●Packaging	40

■Handling Precautions for Traverse Deck

The laser diode in the traverse deck (optical pickup) may break down due to potential difference caused by static electricity of clothes or human body.

So, be careful of electrostatic breakdown during repair of the traverse deck (optical pickup).

●Handling of traverse deck (optical pickup)

1. Do not subject the traverse deck (optical pickup) to static electricity as it is extremely sensitive to electrical shock.
2. To prevent the breakdown of the laser diode, an anti-static shorting pin is inserted into the flexible board (FPC board).
When removing or connecting the short pin, finish the job in as short time as possible.
3. Take care not to apply excessive stress to the flexible board (FPC board).
4. Do not turn the variable resistor (laser power adjustment). It has already been adjusted.

●Grounding for electrostatic breakdown prevention

1. Human body grounding
Use the anti-static wrist strap to discharge the static electricity from your body.
2. Work table grounding
Put a conductive material (sheet) or steel sheet on the area where the traverse deck (optical pickup) is placed, and ground the sheet.

Caution:

The static electricity of your clothes will not be grounded through the wrist strap. So, take care not to let your clothes touch the traverse deck (optical pickup).

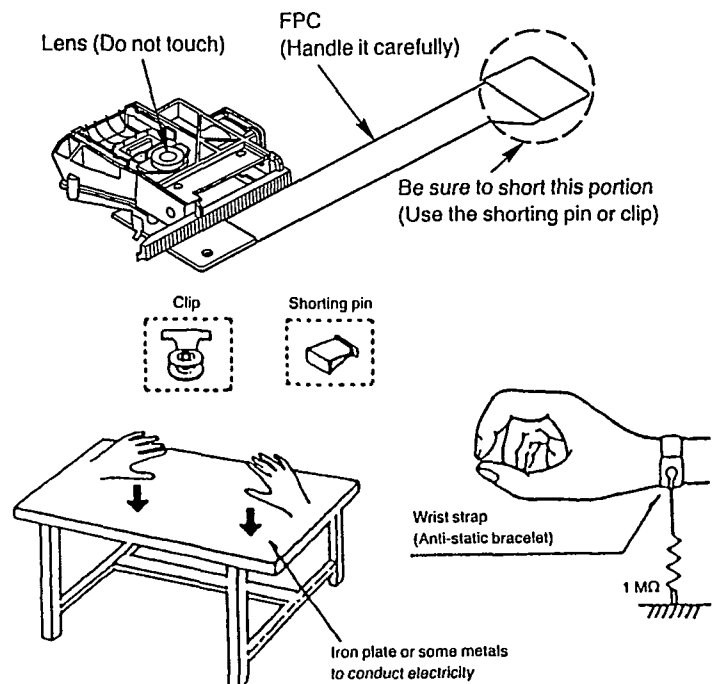

■Precaution of Laser Diode

CAUTION: This product utilizes a laser diode with the unit turned "on", invisible laser radiation is emitted from the pick up lens.
Wave length: 780 nm
Maximum output radiation power from pick up: 100 μW/VDE

Laser radiation from the pick up unit is safety level, but be sure the followings:

1. Do not disassemble the optical pick up unit, since radiation from exposed laser diode is dangerous.
2. Do not adjust the variable resistor on the pickup unit. It was already adjusted.
3. Do not look at the focus lens using optical instruments.
4. Recommend not to look at pick up lens for a long time.

ACHTUNG: Dieses produkt enthält eine laserdioden. Im eingeschalteten zustand wird unsichtbare laserstrahlung von der lasereinheit abgestrahlt.

Wellenlänge: 780 nm
Maximale strahlungsleistung der lasereinheit: 100 μW/VDE

Die strahlung an der lasereinheit ist ungefährlich, wenn folgende punkte beachtet werden:

1. Die lasereinheit nicht zerlegen, da die strahlung an der freigelegten laserdioden gefährlich ist.
2. Den werksseitig justierten einstellregler der lasereinheit nicht verstellen.
3. Nicht mit optischen instrumenten in die fokussierlinse blicken.
4. Nicht über längere zeit in die fokussierlinse blicken.

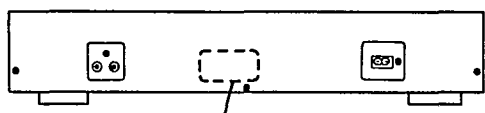

**CLASS 1
LASER PRODUCT**

**LUOKAN 1 LASERLAITE
KLASS 1 LASER APPARAT**

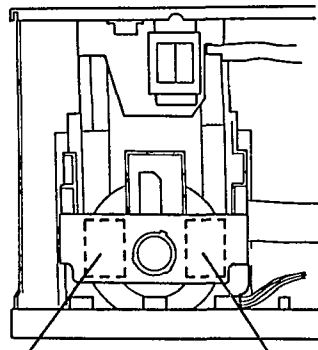

VARO! Avattaessa ja suojalukitus ohitettaessa olet alttina näkymätön laser säteilylle. Älä katso säteeseen.

ADVERSE! Usynlig laserstråling når deksel åpnes og sikkerhetslås brytes. Unngå eksponering for strålen.

WARNING! Osynlig laserstråling når denna del är öppnad och spärren är urkopplad. Betrakta ej strålen.

VORSICHT - Unsichtbare Laserstrahlung, wenn Abdeckung geöffnet. Nicht dem Strahl aussetzen.

ADVARSEL: USYNLIG LASERSTRÅLING VED ÅBNING, NÅR SIKKERHEDSAFBRYDERE ER UDE AF FUNKTION. UNDGÅ UDSÆTTELSE FOR STRÅLING.

DANGER-invisible laser radiation when open. AVOID DIRECT EXPOSURE TO BEAM.

Accessories

- AC mains lead 1 pc.
(For United Kingdom: RJA0034-P) (For others: RJA0043-C)

- Stereo connection cable 1 pc.
(SJP2249-3)

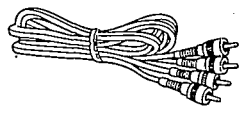
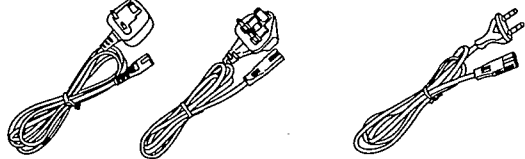

Connections

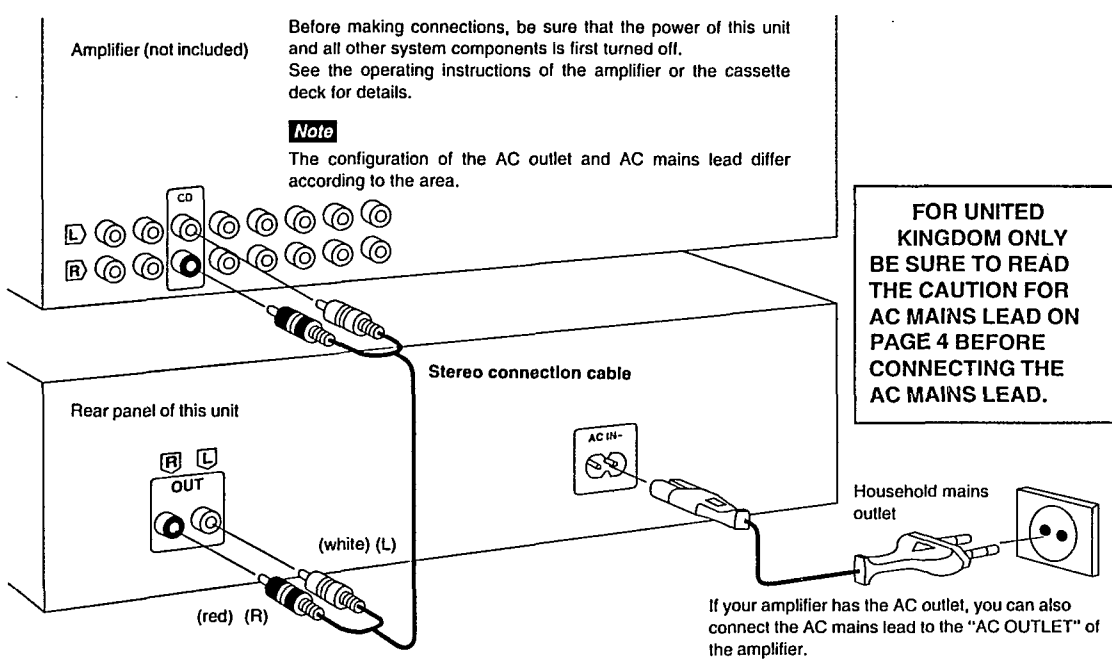

■ Caution for AC Mains Lead (For United Kingdom)

("EB" area code model only)

For your safety, please read the following text carefully.

This appliance is supplied with a moulded three pin mains plug for your safety and convenience.

A 5-ampere fuse is fitted in this plug.

Should the fuse need to be replaced please ensure that the replacement fuse has a rating of 5-ampere and that it is approved by ASTA or BSI to BS1362.

Check for the ASTA mark  or the BSI mark  on the body of the fuse.

If the plug contains a removable fuse cover you must ensure that it is refitted when the fuse is replaced.

If you lose the fuse cover the plug must not be used until a replacement cover is obtained.

A replacement fuse cover can be purchased from your local dealer.

CAUTION!

IF THE FITTED MOULDED PLUG IS UNSUITABLE FOR THE SOCKET OUTLET IN YOUR HOME THEN THE FUSE SHOULD BE REMOVED AND THE PLUG CUT OFF AND DISPOSED OF SAFELY.

THERE IS A DANGER OF SEVERE ELECTRICAL SHOCK IF THE CUT OFF PLUG IS INSERTED INTO ANY 13-AMPERE SOCKET.

If a new plug is to be fitted please observe the wiring code as shown below.

If in any doubt please consult a qualified electrician.

IMPORTANT

If the socket outlets in the home are not suitable for the plug supplied with this appliance it should be cut off and an appropriate three pin plug fitted.

The wires in this mains lead are coloured in accordance with the following code:

Blue: Neutral

Brown: Live

Do not connect either wire to the earth terminal in the plug which is marked by the letter "E" or by the safety earth symbol  or coloured green or green-and-yellow.

As the colours of the wires in the mains lead of this apparatus may not correspond with the coloured markings identifying the terminals in your plug proceed as follows. The wire which is coloured BLUE must be connected to the terminal which is marked with the letter N or coloured BLACK.

The wire which is coloured BROWN must be connected to the terminal which is marked with the letter L or coloured RED.

Before use

Remove the connector cover as follows.

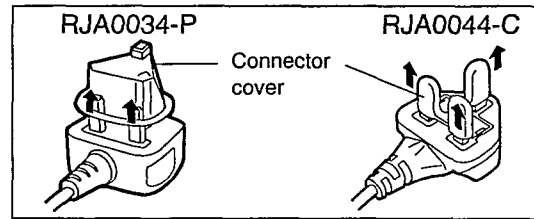

How to replace the fuse

1. Open the fuse cover with a screwdriver.

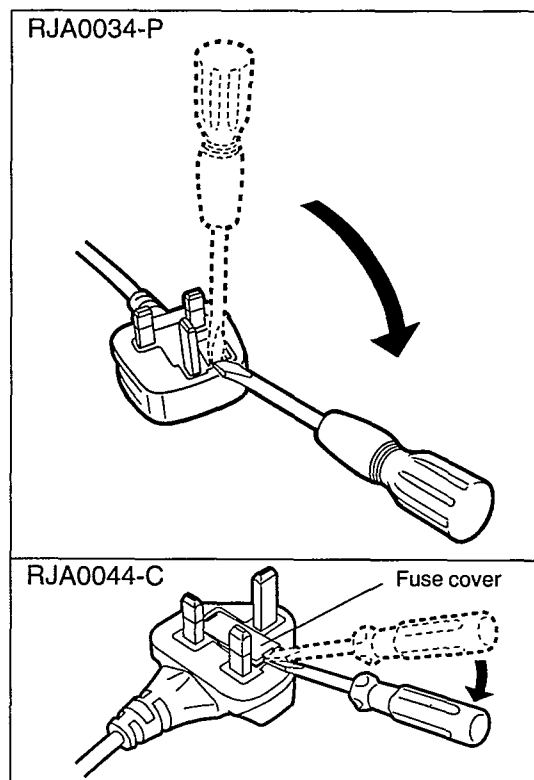

2. Replace the fuse and close or attach the fuse cover.

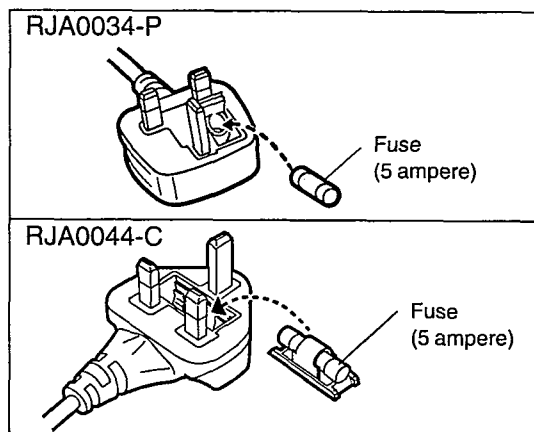

■ Location of Controls

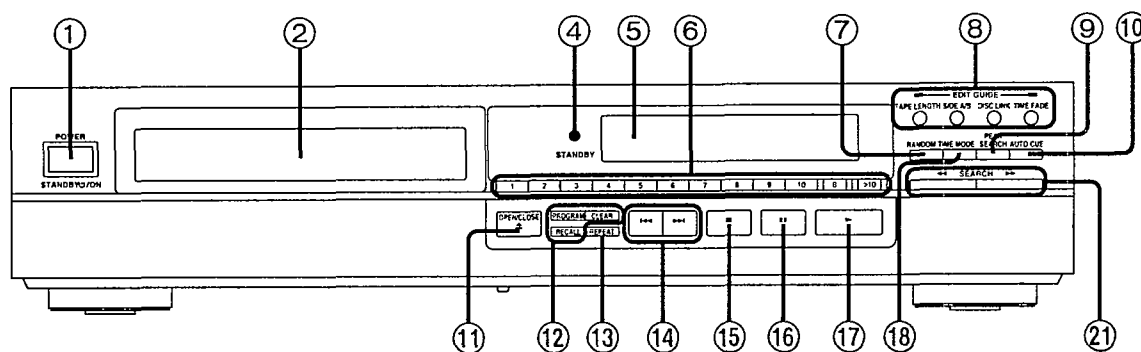

No.	Name
①	Power “STANDBY ⏻/ON” switch (POWER, STANDBY ⏻/ON) Press to switch the unit from on to standby mode or vice versa. In standby mode, the unit is still consuming a small amount of power.
②	Disc tray
④	Standby indicator (STANDBY) When the unit is connected to the AC mains supply, this indicator lights up in standby mode and goes out when the unit is turned on.
⑤	Display panel
⑥	Numeric buttons (1–10, 0, >10)
⑦	Random play button (RANDOM)
⑧	CD edit record buttons (EDIT GUIDE) <ul style="list-style-type: none"> ●Tape length button (TAPE LENGTH) ●Tape side switch button (SIDE A/B) ●Disc link button (DISC LINK) ●Time fade button (TIME FADE)
⑨	Peak search button (PEAK SEARCH)
⑩	Auto cue button (AUTO CUE)



No.	Name
⑪	Disc tray open/close button (\blacktriangle OPEN/CLOSE)
⑫	Program play buttons <ul style="list-style-type: none"> ●Program button (PROGRAM) ●Clear button (CLEAR) ●Recall button (RECALL)
⑬	Repeat button (REPEAT)
⑭	Skip buttons (\blacktriangleleft, \blacktriangleright)
⑮	Stop button (\blacksquare)
⑯	Pause button (⏸)
⑰	Play button (\blacktriangleright)
⑱	Time mode select button (TIME MODE)
⑳	Search buttons (\blacktriangleleft SEARCH \blacktriangleright)

Basic Operating Procedure

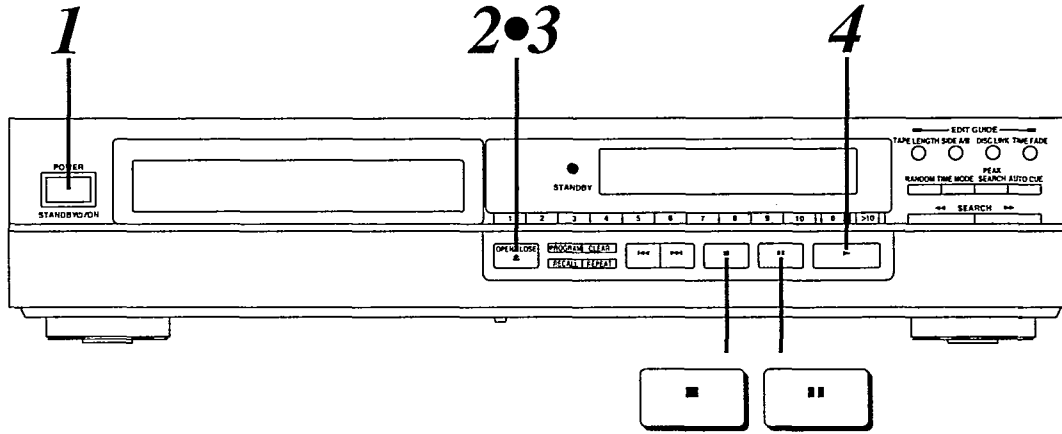
With this function, a disc is played from the first track to the last track and then stops automatically.

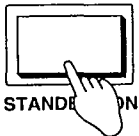

1 **POWER**
 Press **POWER** (Power goes on).
 If a compact disc is already in the disc tray, it automatically begins playing from the first track.

2 **OPEN/CLOSE**
 Press **▲ OPEN/CLOSE** to open the tray and insert a disc.
 Label must face upward

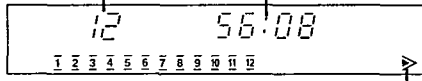
3 **OPEN/CLOSE**
 Press **▲ OPEN/CLOSE** to close the tray.
 Total number of tracks Total playing time

 Displayed if there are 21 or more tracks on the disc

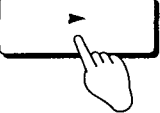
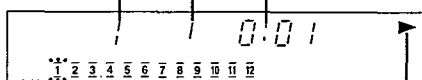
On SL-PG360A, this indicator appears when there are 17 or more tracks on the disc.

4 **▶ (Play begins)**
 Press **▶ (Play begins)**.
 Play stops automatically after all tracks have been played.
 Index number
 (If there is none, " / " is displayed.)
 Track currently playing Elapsed time

 Illuminates.

To stop disc play

Press **■**.

To pause disc play

Press **⏸**.

 To continue playback, press **▶**.

Notes

- The displayed total playing time includes the time between tracks. For this reason, the time may be several seconds longer than that which appears on song cards and the like.
- When you use the timer with other unit, be sure to turn this unit on.

For your reference:

If you skip step 3 and press **▶**, the tray automatically closes and play begins from the first track.

■Disassembly Instructions







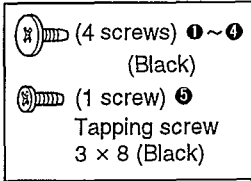
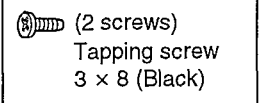
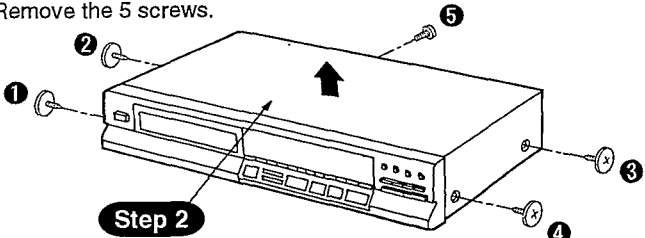
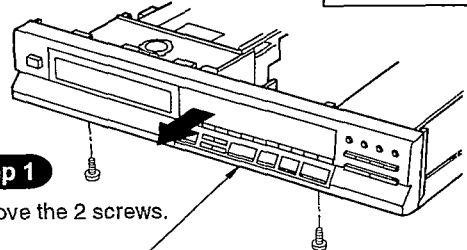
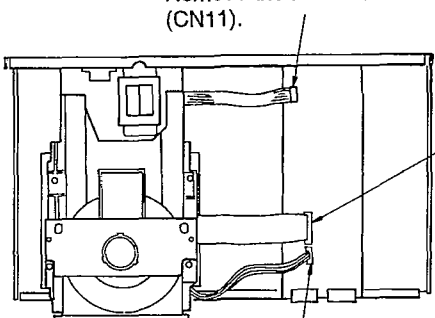
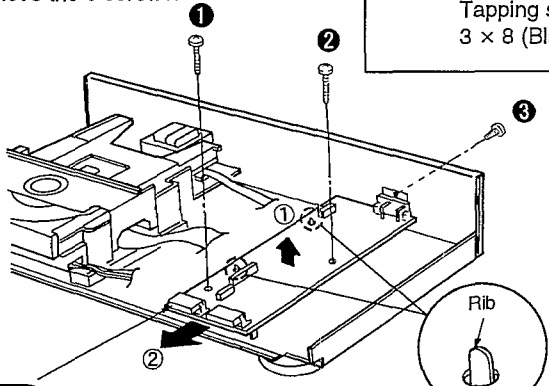
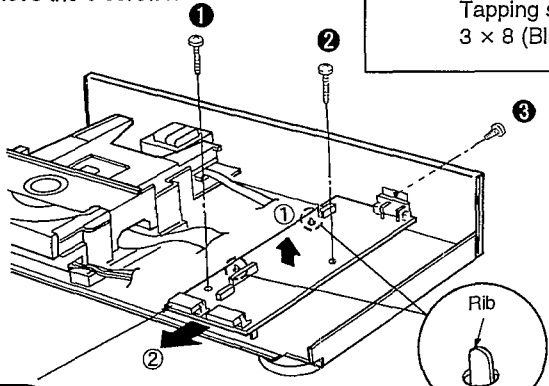
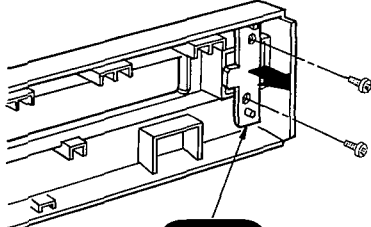

Warning: This product uses a laser diode. Refer to caution statements on page 2.

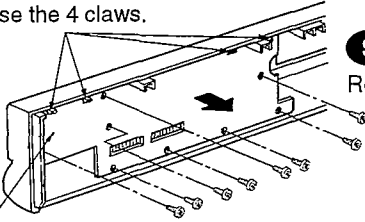

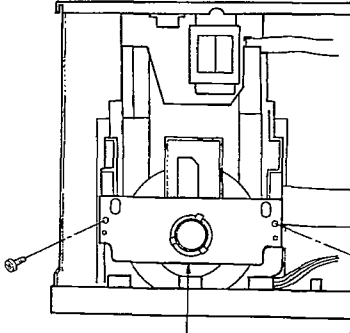
ACHTUNG: Die Lasereinheit nicht zerlegen.

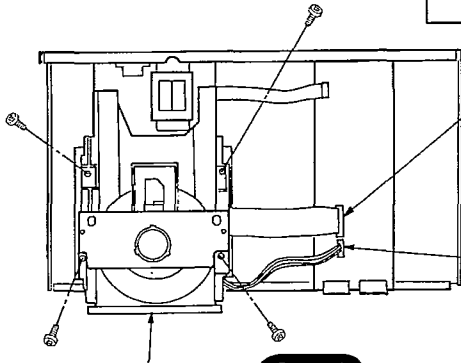
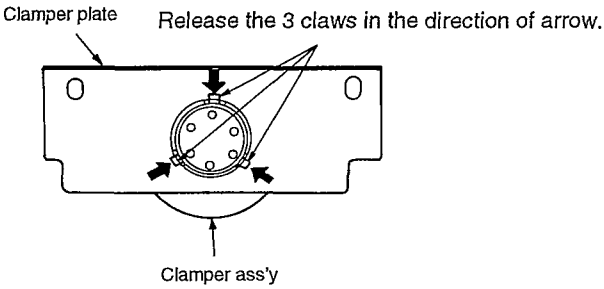

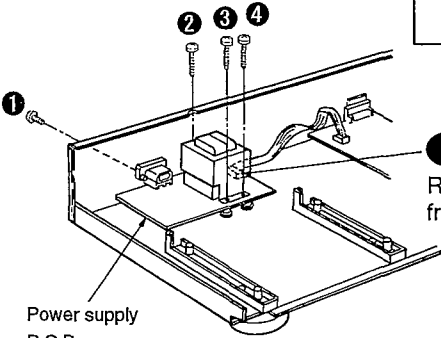
Die Lasereinheit darf nur gegen eine vom Hersteller spezifizierte Einheit ausgetauscht werden.

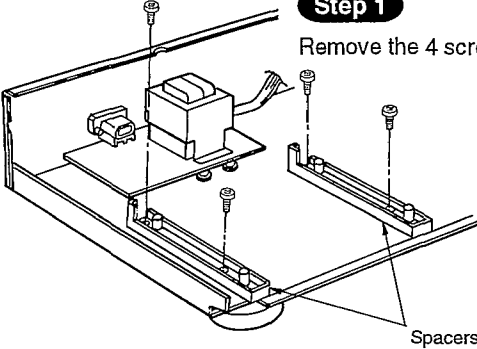
"ATTENTION SERVICER" Some chassis components may have sharp edges. Be careful when disassembling and servicing.

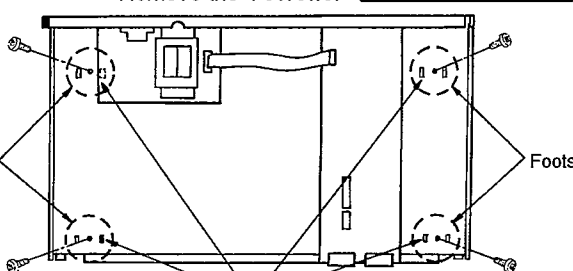
Ref. No. 1	Removal of the cabinet	Ref. No. 2	Removal of the front panel ass'y
Procedure 1	 <p>(4 screws) ①~④ (Black) (1 screw) ⑤ Tapping screw 3 × 8 (Black)</p>	Procedure 1→2	 <p>(2 screws) Tapping screw 3 × 8 (Black)</p>
<p>Step 1 Remove the 5 screws.</p>  <p>Step 2 Remove the cabinet in the direction of arrow.</p>		<p>Step 1 Remove the 2 screws.</p>  <p>Step 2 Remove the front panel ass'y in the direction of arrow.</p>	
Ref. No. 3	Removal of the main P.C.B.		
Procedure 1→2→3	<p>Step 1 Remove the flat cable from connector (CN11).</p>  <p>Step 2 Pull out the flexible cable from connector (CN401).</p> <p>Step 3 Remove the connector (CN402).</p>	<p>Step 4 Remove the 3 screws.</p>  <p>(2 screws) ①, ② Tapping screw 3 × 20 (Black) (1 screw) ③ Tapping screw 3 × 8 (Black)</p>	
		<p>Step 5 Lift up the main P.C.B. in the direction of arrow ①, and release the 2 ribs on the chassis ass'y. Then, remove the main P.C.B. in the direction of arrow ②.</p>  <p>Rib</p>	
Ref. No. 4	Removal of the power switch P.C.B.		
Procedure 1→2→4	<p>Step 1 Remove the 2 screws.</p>  <p>Step 2 Remove the power switch P.C.B. in the direction of arrow.</p>		<p>(2 screws) Tapping screw 2.6 × 8</p>

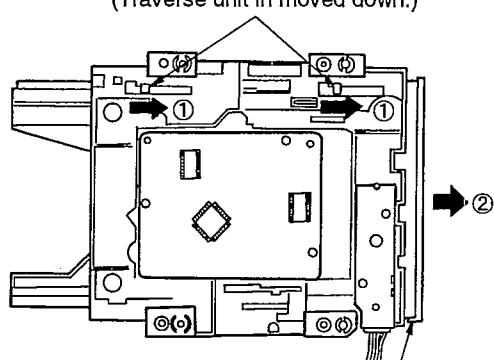
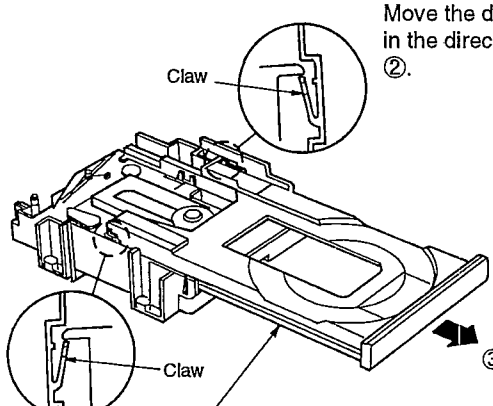
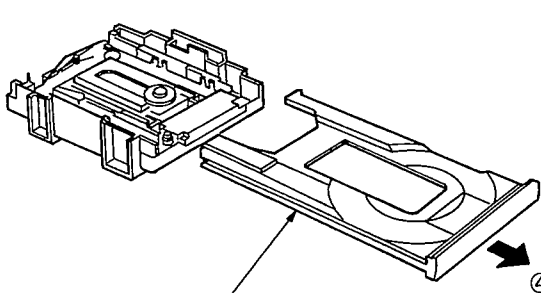
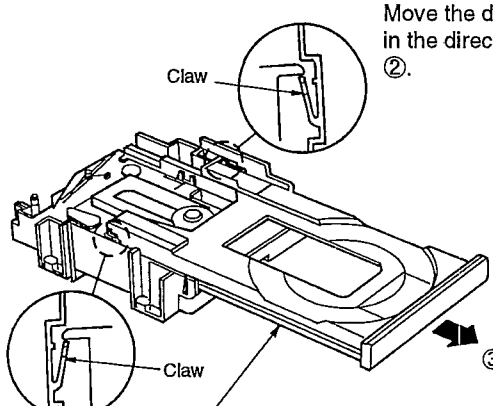
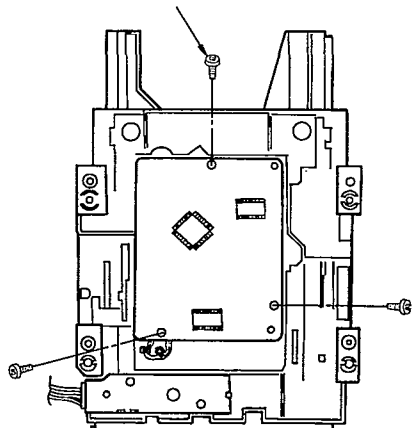
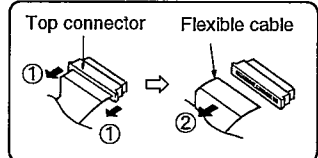
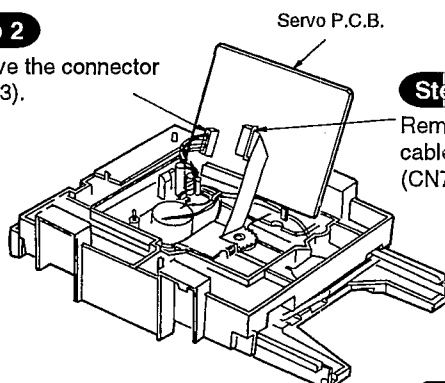
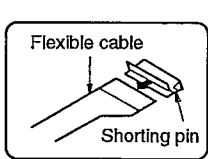
<p>Ref. No. 5</p>	<p>Removal of the operation P.C.B.</p>	<p>Ref. No. 6</p>	<p>Removal of the clamber plate and clamber ass'y</p>
<p>Procedure 1→2→5</p>	<div data-bbox="496 210 751 315" style="border: 1px solid black; padding: 5px;">  (8 screws) Tapping screw 2.6 × 8 </div> <div data-bbox="113 297 220 331" style="background-color: black; color: white; border-radius: 50%; padding: 2px 5px; display: inline-block;">Step 2</div> <p>Release the 4 claws.</p> <div data-bbox="177 331 544 551">  </div> <div data-bbox="528 365 635 398" style="background-color: black; color: white; border-radius: 50%; padding: 2px 5px; display: inline-block;">Step 1</div> <p>Remove the 8 screws.</p> <div data-bbox="113 562 220 595" style="background-color: black; color: white; border-radius: 50%; padding: 2px 5px; display: inline-block;">Step 3</div> <p>Remove the operation P.C.B. in the direction of arrow.</p>	<p>Procedure 1→6</p>	<div data-bbox="1214 210 1469 315" style="border: 1px solid black; padding: 5px;">  (2 screws) Tapping screw 3 × 8 (Black) </div> <div data-bbox="1214 551 1321 584" style="background-color: black; color: white; border-radius: 50%; padding: 2px 5px; display: inline-block;">Step 1</div> <p>Remove the 2 screws.</p> <div data-bbox="807 309 1158 640">  </div> <div data-bbox="927 651 1034 685" style="background-color: black; color: white; border-radius: 50%; padding: 2px 5px; display: inline-block;">Step 2</div> <p>Remove the clamber plate.</p>
<p>Ref. No. 7</p>	<p>Removal of the loading unit</p>	<p>Ref. No. 6</p>	<p>Removal of the clamber plate and clamber ass'y</p>
<p>Procedure 1→2→7</p>	<div data-bbox="507 801 762 907" style="border: 1px solid black; padding: 5px;">  (4 screws) Tapping screw 3 × 8 (Black) </div> <div data-bbox="571 952 662 985" style="background-color: black; color: white; border-radius: 50%; padding: 2px 5px; display: inline-block;">Step 1</div> <p>Pull out the flexible cable from connector (CN401).</p> <div data-bbox="81 884 544 1245">  </div> <div data-bbox="571 1126 662 1160" style="background-color: black; color: white; border-radius: 50%; padding: 2px 5px; display: inline-block;">Step 2</div> <p>Remove the connector (CN402).</p> <div data-bbox="336 1238 443 1272" style="background-color: black; color: white; border-radius: 50%; padding: 2px 5px; display: inline-block;">Step 3</div> <p>Remove the 4 screws.</p>	<p>Procedure 1→2→7→9</p>	<div data-bbox="986 875 1093 909" style="background-color: black; color: white; border-radius: 50%; padding: 2px 5px; display: inline-block;">Step 3</div> <p>Release the 3 claws in the direction of arrow.</p> <div data-bbox="823 913 1430 1200">  </div>
<p>Ref. No. 8</p>	<p>Removal of the power supply P.C.B.</p>	<p>Ref. No. 9</p>	<p>Removal of the spacer</p>
<p>Procedure 1→2→7→8</p>	<div data-bbox="507 1527 762 1697" style="border: 1px solid black; padding: 5px;">  (1 screw) ① Tapping screw 3 × 8 (Black)  (3 screws) ②~④ Tapping screw 3 × 20 (Black) </div> <div data-bbox="113 1585 220 1619" style="background-color: black; color: white; border-radius: 50%; padding: 2px 5px; display: inline-block;">Step 1</div> <p>Remove the 4 screws.</p> <div data-bbox="81 1659 523 1995">  </div> <div data-bbox="523 1794 614 1827" style="background-color: black; color: white; border-radius: 50%; padding: 2px 5px; display: inline-block;">Step 2</div> <p>Remove the flat cable from connector (CN21).</p>	<p>Procedure 1→2→7→9</p>	<div data-bbox="1214 1527 1469 1632" style="border: 1px solid black; padding: 5px;">  (4 screws) Tapping screw 3 × 8 (Black) </div> <div data-bbox="1118 1637 1225 1671" style="background-color: black; color: white; border-radius: 50%; padding: 2px 5px; display: inline-block;">Step 1</div> <p>Remove the 4 screws.</p> <div data-bbox="823 1648 1302 1995">  </div>

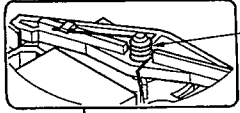
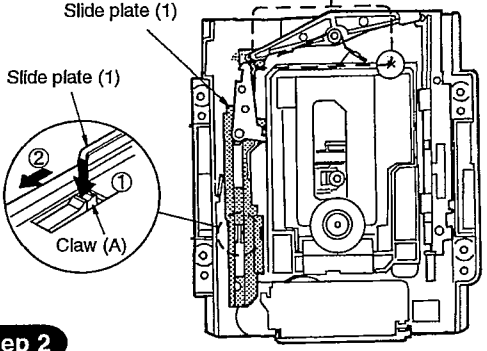
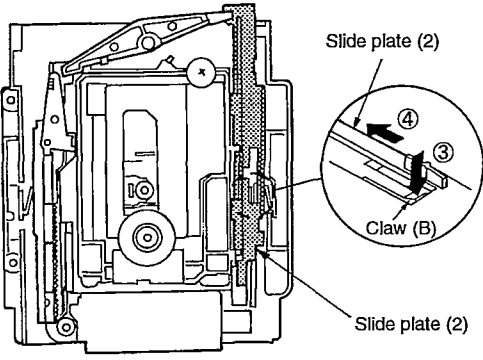
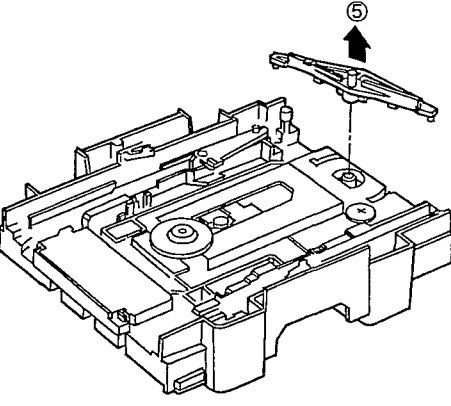
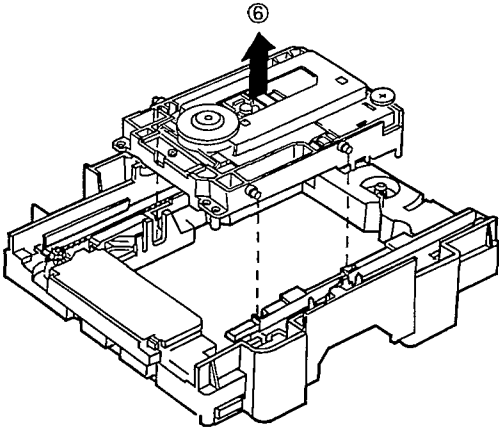
<p>Ref. No. 10</p>	<p>Removal of the foots</p>	<p>Ref. No. 11</p>	<p>Removal of the disc tray</p>
<p>Procedure 1→2→7→9→10</p>	<p>Step 1 Remove the 4 screws.</p> <p>(4 screws) Tapping screw 3 × 8 (Black)</p>  <p>Foots</p> <p>Step 2 Release the 8 claws.</p>  <p>Claws</p>	<p>Procedure 1→2→6→7→11</p>	<p>Step 1 Push the 2 levels fully in the direction of the arrows ①. (Traverse unit in moved down.)</p>  <p>Step 2 Move the disc tray slightly in the direction of arrow ②.</p>  <p>Claw</p> <p>Claw</p>
<p>Step 4 Remove the disc tray in the direction of arrow ④.</p> 	<p>Step 3 Release the 2 claws, and then move the disc tray in the direction of arrow ③.</p>  <p>Claw</p> <p>Claw</p>		
<p>Ref. No. 12</p>	<p>Removal of the servo P.C.B.</p>		
<p>Procedure 1→2→7→12</p>	<p>Step 1 Remove the 3 screws.</p> <p>(3 screws) Tapping screw 2.6 × 8</p> 	<p>Removal of the flexible cable ● Push the top of the connector in the direction of arrow ①, and then pull out the flexible cable in the direction of arrow ②.</p>  <p>Top connector</p> <p>Flexible cable</p> <p>Step 2 Remove the connector (CN703).</p>  <p>Servo P.C.B.</p> <p>Step 3 Remove the flexible cable from connector (CN701).</p>  <p>Flexible cable</p> <p>Shorting pin</p> <p>Note: Insert a shorting pin into the traverse unit flexible cable. (Refer to Handling Precautions for Traverse Deck on page 2.)</p>	

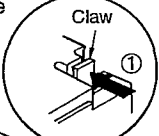
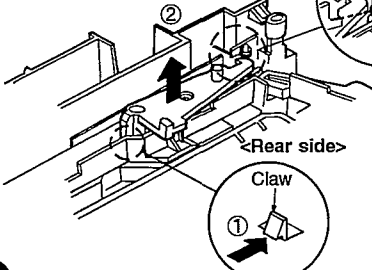
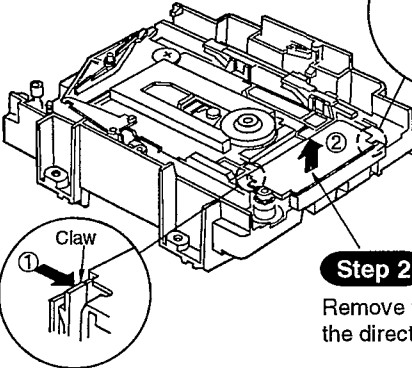
<p>Ref. No. 13</p>	<p>Removal of the converter lever and traverse deck ass'y</p>	<p>Note: Be careful not to damage the claw (A) or (B) because the claw (A) or (B) is breakable.</p>	
<p>Procedure 1→2→6→7→ 11→12→13</p>	<div style="display: flex; justify-content: space-between;"> <div style="width: 45%;"> <p>Step 1 Remove the spring.</p>  </div> <div style="width: 45%;"> <p>Step 2 Push the claw (A) in the direction of arrow ①, and then move the slide plate (1) in the direction of arrow ②.</p>  </div> </div> <div style="display: flex; justify-content: space-between; margin-top: 20px;"> <div style="width: 45%;"> <p>Step 3 Push the claw (B) in the direction of arrow ③, and then move the slide plate (2) in the direction of arrow ④.</p>  </div> <div style="width: 45%;"> <p>Step 4 Remove the converter lever in the direction of arrow ⑤.</p>  </div> </div> <div style="display: flex; justify-content: space-between; margin-top: 20px;"> <div style="width: 45%;"> <p>Step 5 Remove the traverse deck ass'y in the direction of arrow ⑥.</p>  </div> </div>		
<p>Ref. No. 14</p>	<p>Removal of the lock lever</p>	<p>Ref. No. 15</p>	<p>Removal of the gear cover</p>
<p>Procedure 1→2→6→7 →11→14</p>	<div style="display: flex; justify-content: space-between;"> <div style="width: 45%;"> <p>Step 1 Remove the spring.</p>  </div> <div style="width: 45%;"> <p>Step 1 Release the 2 claws in the direction of arrow ①.</p>  </div> </div> <div style="display: flex; justify-content: space-between; margin-top: 20px;"> <div style="width: 45%;"> <p>Step 2 Push the claw in the direction of arrow ① and then lift up the lock lever in the direction of arrow ②.</p>  </div> <div style="width: 45%;"> <p>Step 2 Remove the gear cover in the direction of arrow ②.</p>  </div> </div>		

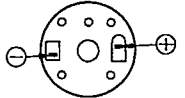
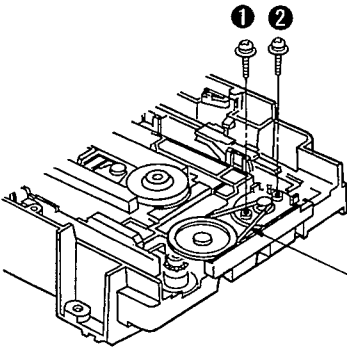
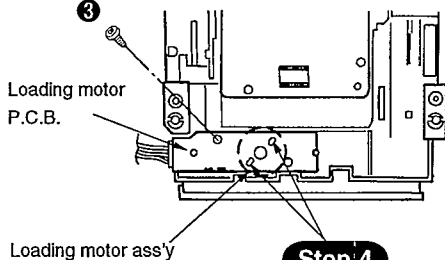
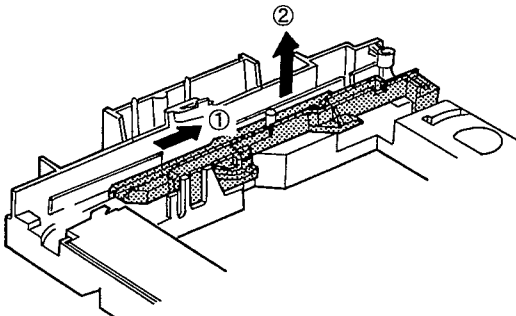
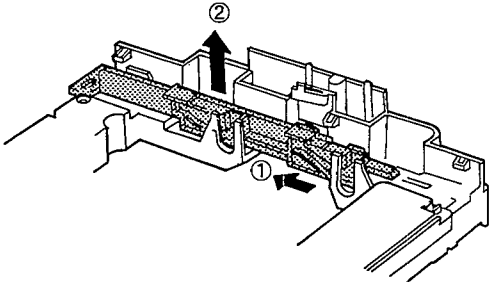
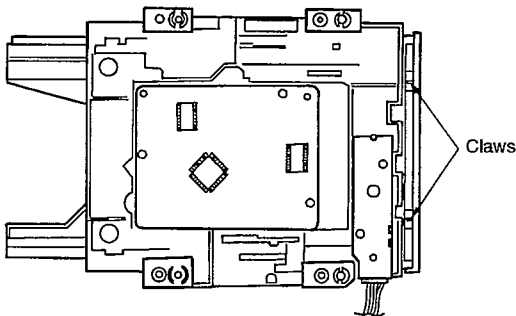
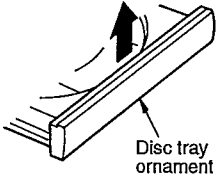
<p>Ref. No. 16</p>	<p>Removal of the loading motor P.C.B. and loading motor ass'y</p>	<div data-bbox="1262 114 1501 282" style="border: 1px solid black; padding: 5px;"> <p>Polarity of loading motor ass'y terminals</p>  </div> <div data-bbox="384 203 608 271" style="border: 1px solid black; padding: 5px;"> <p>Step 1 Remove the 2 screws.</p> </div> <div data-bbox="159 304 507 651" style="border: 1px solid black; padding: 5px;">  </div> <div data-bbox="531 286 799 481" style="border: 1px solid black; padding: 5px;"> <p>(2 screws) ①, ② Tapping screw 2 × 6 (Black)</p> <p>(1 screw) ③ Tapping screw 2.6 × 8</p> </div> <div data-bbox="531 577 699 645" style="border: 1px solid black; padding: 5px;"> <p>Step 2 Remove the belt.</p> </div> <div data-bbox="874 241 1082 309" style="border: 1px solid black; padding: 5px;"> <p>Step 3 Remove the 1 screw.</p> </div> <div data-bbox="842 331 1289 589" style="border: 1px solid black; padding: 5px;">  </div> <div data-bbox="1121 566 1457 667" style="border: 1px solid black; padding: 5px;"> <p>Step 4 Unsolder the loading motor ass'y terminals (2 points).</p> </div>	
<p>Ref. No. 17</p>	<p>Removal of the slide plate (1)</p>	<p>Ref. No. 18</p>	<p>Removal of the slide plate (2)</p>
<p>Procedure 1→2→6→7→ 11→12→13→ 14→17</p>	<p>Step 1 Move the slide plate (1) in the direction of arrow ①, and lift up the slide plate (1) in the direction of arrow ②.</p>	<p>Procedure 1→2→6→7→11 →12→13→18</p>	<p>Step 1 Move the slide plate (2) in the direction of arrow ①, and lift up the slide plate (2) in the direction of arrow ②.</p>
			
<p>Ref. No. 19</p>	<p>Removal of the disc tray ornament</p>		
<p>Procedure 1→2→7→19</p>	<p>Step 1 Release the 2 claws, and then remove the disc tray ornament in the direction of arrow.</p>		
		<div data-bbox="850 1686 1137 1933" style="border: 1px solid black; padding: 5px;">  </div>	

Ref. No. 20 **Removal of the traverse deck**

Procedure
 1→2→6→7→
 11→12→13→
 20

Step 1
 Remove the 2 screws.

Step 2
 Remove the traverse stopper

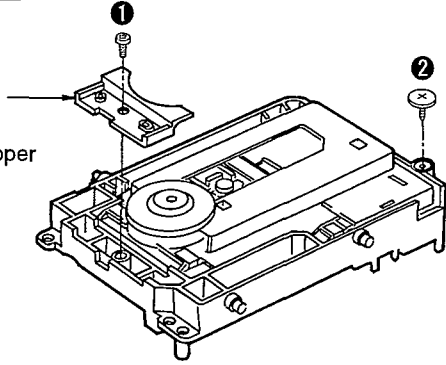

Step 3
 Remove the lead wire from clamber.

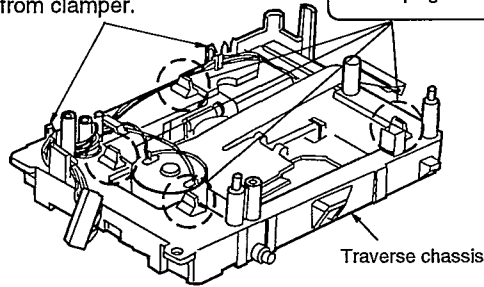

Step 4
 Push the damping rubber in the direction of arrow ①, and then remove it from traverse chassis.

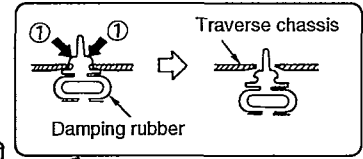

Ref. No. 21 **Removal of the drive rack**

Procedure
 1→2→6→7
 →11→21

(1 screw) ①
 Tapping screw
 2 × 5 (Black)

Step 1 Remove the 1 screw.

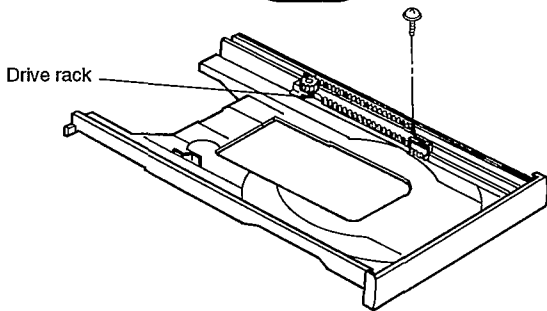

(1 screw) ②
 Tapping screw
 2.6 × 8 (Black)
 (1 screw) ③
 Tapping screw
 3 × 8

Step 5
 Remove the traverse deck in the direction of arrow ②.

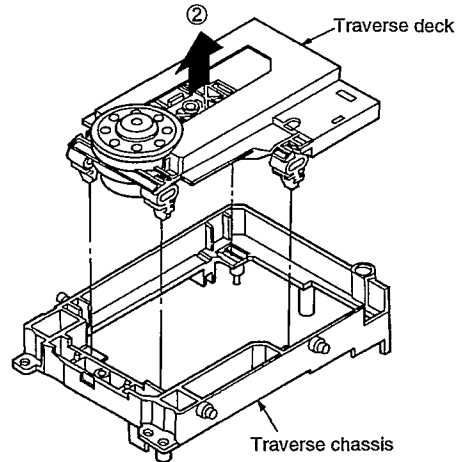

■Installing Disc Tray

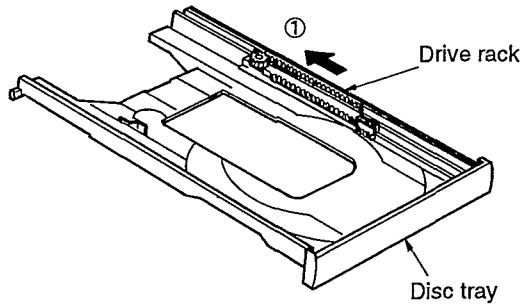

Step 1

Slide the drive rack fully in the direction of arrow ①.

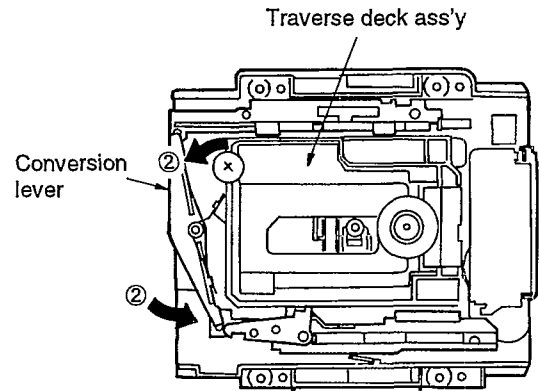

Step 2

Slide the conversion lever in the direction of arrow ②, and then leave the traverse deck ass'y falling.

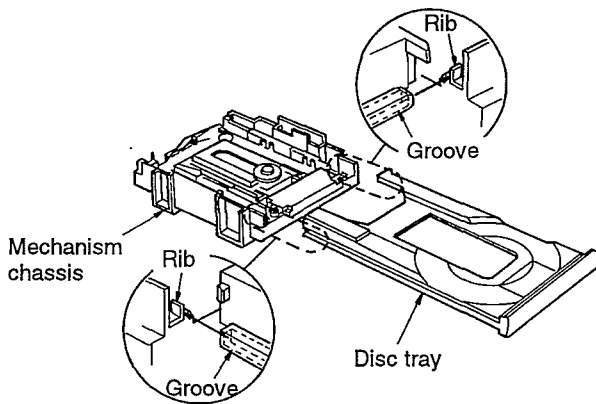

Step 3

Align the disc tray groove with the mechanism chassis rib.

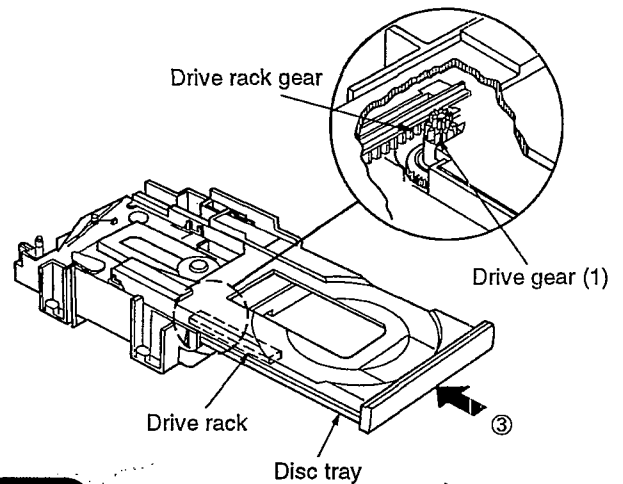

Step 4

Slide the disc tray in the direction of arrow ③. Then, put the drive rack manually so that the drive gear (1) engages with the drive rack gear.

Step 5

After the drive gear (1) engaged with the drive rack gear, slide the disc tray in the direction of arrow ③.

■Dispose of Wire

1. Dispose of wire in due order **a** to **f**.
2. Slacken off the each wire between solder part and each claw.

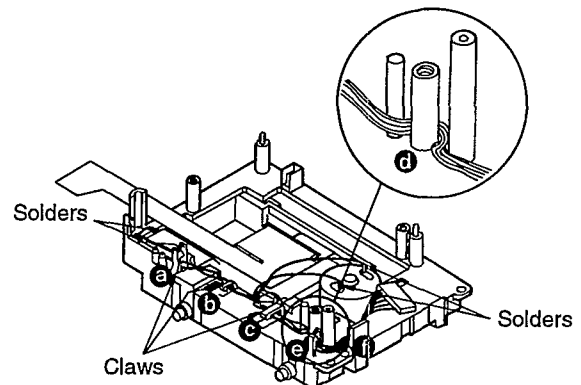

■How to Check the Main P.C.B.

1. Remove the cabinet referring to Procedure 1 "Removal of the cabinet" on page 7.
2. Remove the front panel ass'y referring to Procedure 2 "Removal of the front panel ass'y" on page 7.
3. Remove the operation P.C.B. referring to Procedure 5 "Removal of the operation P.C.B." on page 8.

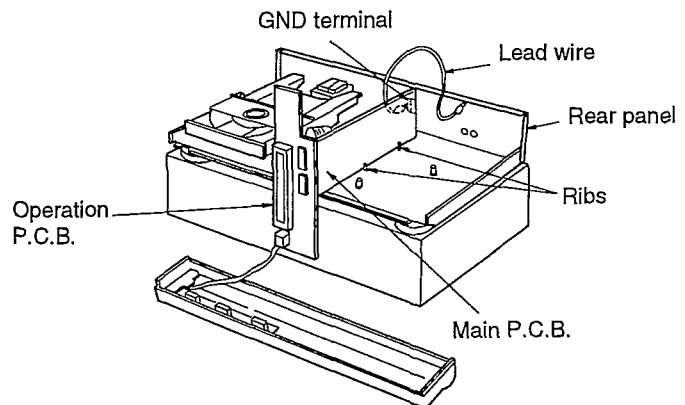
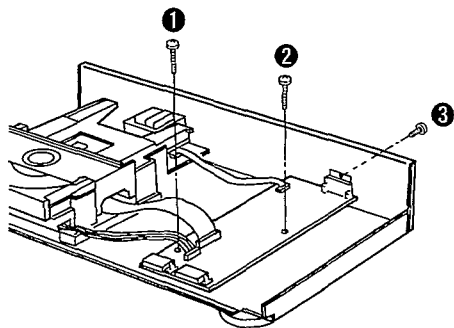

4. Remove the 3 screws (1 ~ 3).
5. Remove the main P.C.B. and then stand the main P.C.B. at the side of unit.

6. Reinstall the operation P.C.B. to the main P.C.B.
7. Connect the GND terminal to the rear panel by the lead wire.
8. When checking the soldered surface of the main P.C.B., do as shown above.

■How to Check the Servo P.C.B.

1. Remove the cabinet referring to Procedure 1 "Removal of the cabinet" on page 7.

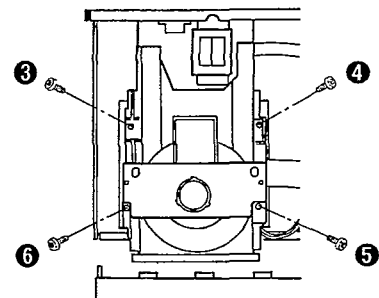
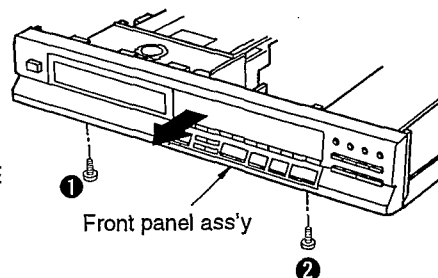
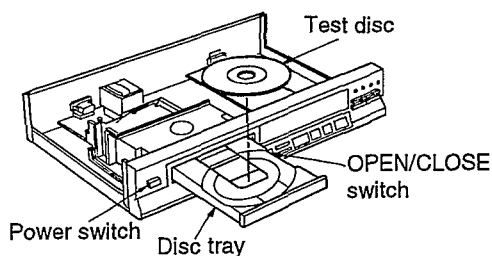

2. Turn on the power and press the OPEN/CLOSE switch to open the disc tray.
3. Load the test disc and press the OPEN/CLOSE switch again to close the disc tray.

4. Turn the power switch "OFF".
5. Remove the 2 screws (1, 2).
6. Draw the front panel ass'y in the direction of arrow.

7. Remove the 4 screws (3 ~ 6).

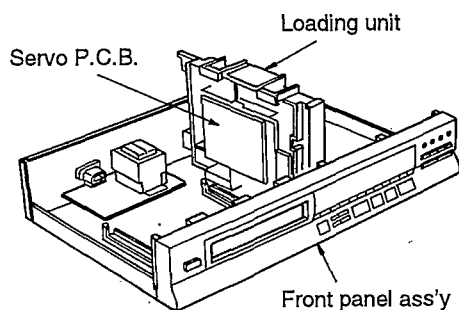

8. Place the loading unit sideways as shown in the figure left.
9. Attach the front panel ass'y to the unit.
10. After placing the unit as shown left, perform check and adjustment of the foil on the servo P.C.B.

Block Diagram

Note: — AUDIO SIGNAL

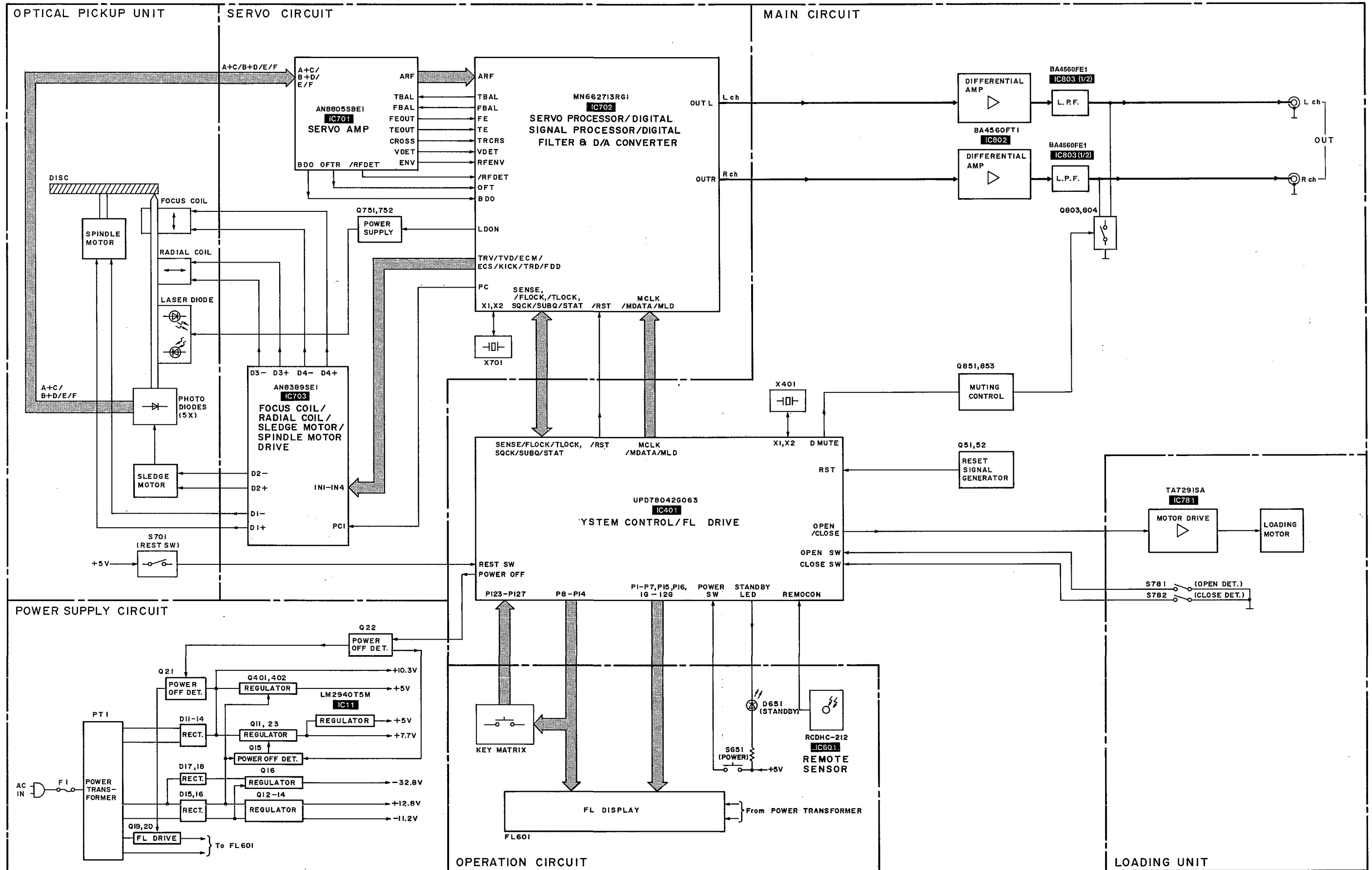

Schematic Diagram • Optical Pickup/Servo Circuit (Parts list on pages 34~36.)

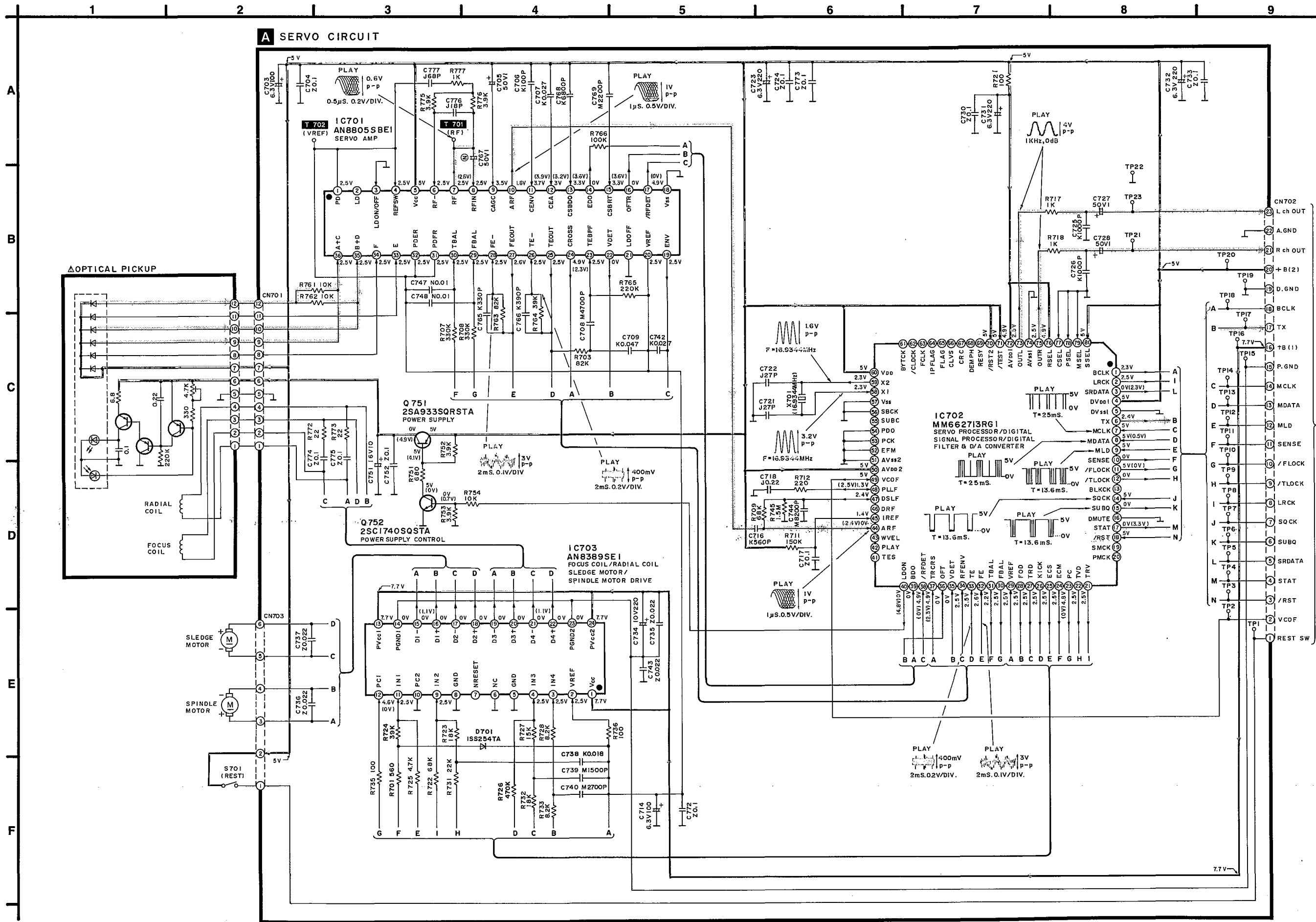

To MAIN CIRCUIT (CN401) (Page 20)

●Main/Operation/Loading Motor/Power Supply Circuit (Parts list on page 34~36.)

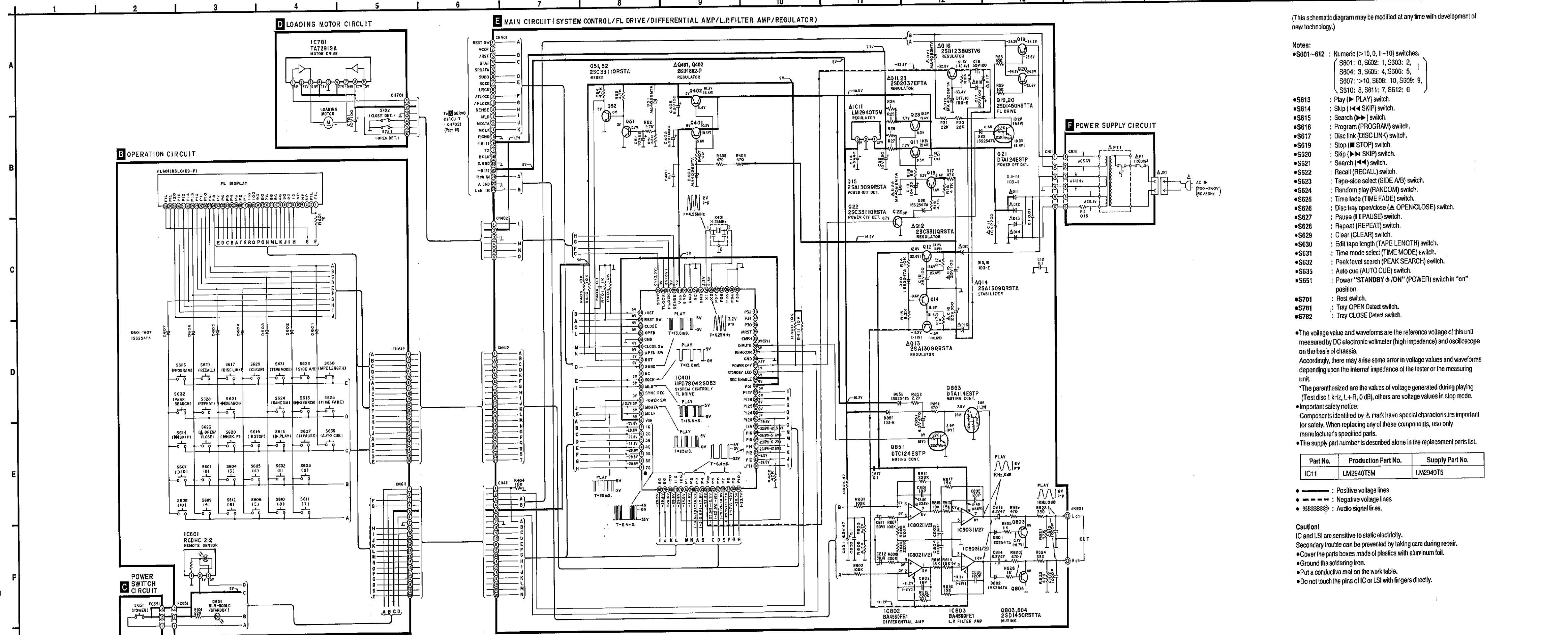

(This schematic diagram may be modified at any time with development of new technology.)

- Notes:
- S601~612 : Numeric (>10, 0, 1~10) switches.
 - (S601: 0, S602: 1, S603: 2, S604: 3, S605: 4, S606: 5, S607: >10, S608: 10, S609: 9, S610: 8, S611: 7, S612: 6)
 - S613 : Play (▶) PLAY switch.
 - S614 : Skip (◀◀) SKIP switch.
 - S615 : Search (▶▶) switch.
 - S616 : Program (PROGRAM) switch.
 - S617 : Disc link (DISC LINK) switch.
 - S619 : Stop (■) STOP switch.
 - S620 : Skip (▶▶) SKIP switch.
 - S621 : Search (◀◀) switch.
 - S622 : Recall (RECALL) switch.
 - S623 : Tape-side select (SIDE A/B) switch.
 - S624 : Random play (RANDOM) switch.
 - S625 : Time fade (TIME FADE) switch.
 - S626 : Disc tray open/close (▲ OPEN/CLOSE) switch.
 - S627 : Pause (||) PAUSE switch.
 - S628 : Repeat (REPEAT) switch.
 - S629 : Clear (CLEAR) switch.
 - S630 : Edit tape length (TAPE LENGTH) switch.
 - S631 : Time mode select (TIME MODE) switch.
 - S632 : Peak level search (PEAK SEARCH) switch.
 - S635 : Auto cue (AUTO CUE) switch.
 - S651 : Power "STANDBY & /ON" (POWER) switch in "on" position.
 - S701 : Rest switch.
 - S781 : Tray OPEN Detect switch.
 - S782 : Tray CLOSE Detect switch.

●The voltage value and waveforms are the reference voltage of this unit measured by DC electronic voltmeter (high impedance) and oscilloscope on the basis of chassis.

Accordingly, there may arise some error in voltage values and waveforms depending upon the internal impedance of the tester or the measuring unit.

*The parenthesized are the values of voltage generated during playing (Test disc 1 kHz, L+R, 0 dB), others are voltage values in stop mode.

●Important safety notice:
Components identified by A mark have special characteristics important for safety. When replacing any of these components, use only manufacturer's specified parts.
●The supply part number is described alone in the replacement parts list.

Part No.	Production Part No.	Supply Part No.
IC11	LM2940T5M	LM2940T5

- ——— : Positive voltage lines
- - - - - : Negative voltage lines
- ———▶ : Audio signal lines.

Caution!
IC and LSI are sensitive to static electricity. Secondary trouble can be prevented by taking care during repair.
●Cover the parts boxes made of plastics with aluminum foil.
●Ground the soldering iron.
●Put a conductive mat on the work table.
●Do not touch the pins of IC or LSI with fingers directly.

Printed Circuit Board Diagram

Wiring Connection Diagram

1 2 3 4 5 6 7 8 9 10 11 12 13 14

This circuit board diagram may be modified at any time with the development of new technology.

B OPERATION P.C.B. (REP1779B-S)

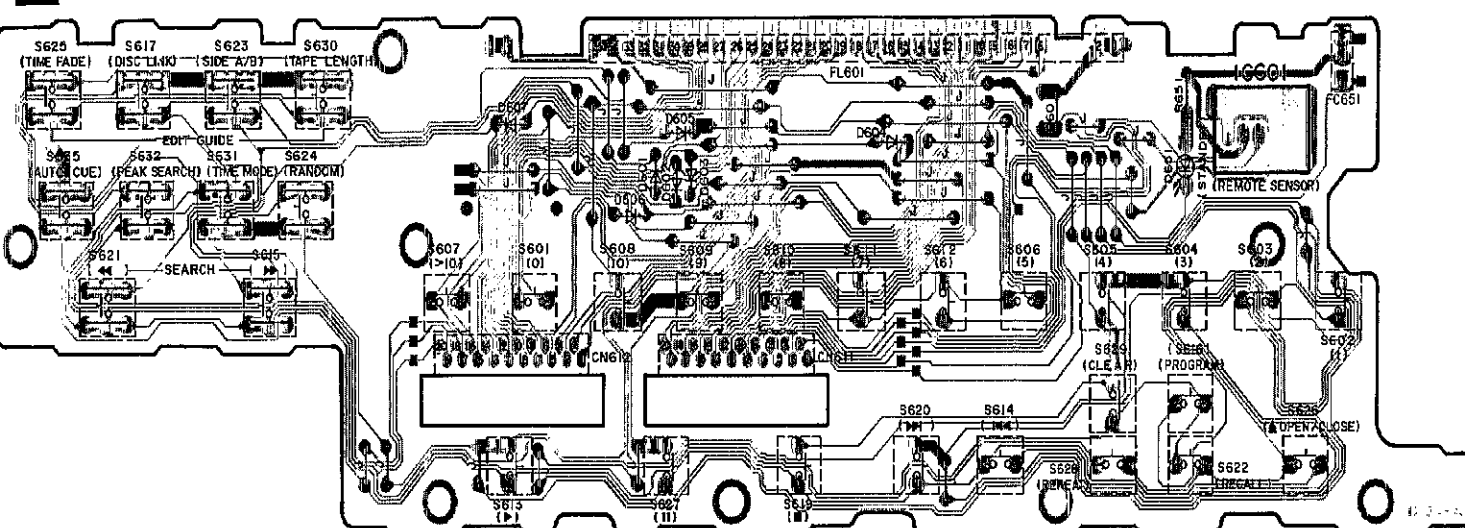

E MAIN P.C.B. (REP1777B-M)

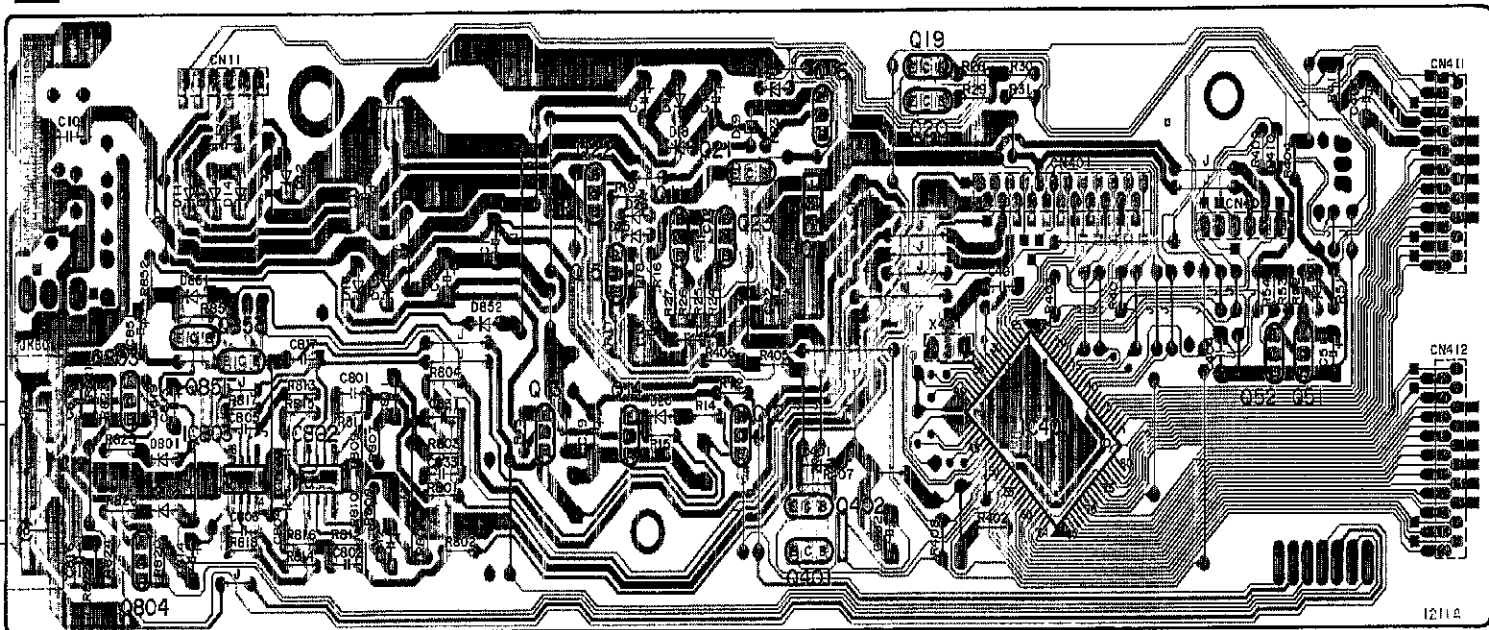

A SERVO P.C.B. (REP1755A-N)

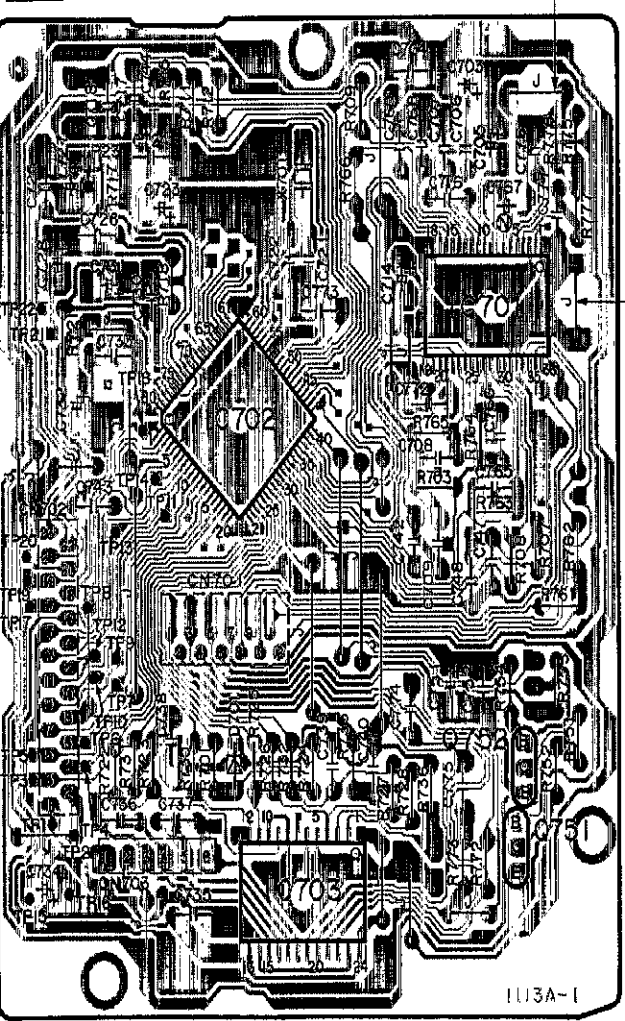

C POWER SWITCH P.C.B. (REP1779B-S)

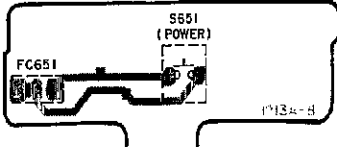

D LOADING MOTOR P.C.B. (REP1755A-N)

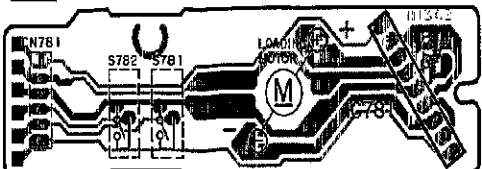

F POWER SUPPLY P.C.B. (REP1781A-P)

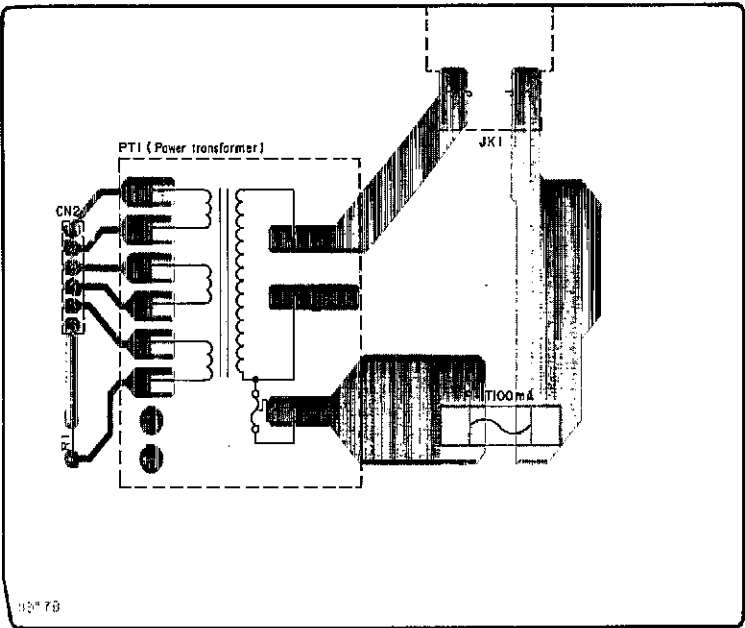

Terminal guide of IC's, transistors and diodes

BA460FE1 	AN8389SE1 	AN8805SBE1 	MN662713RG1 	UPD78042G06S 	TA7291SA
LM2940T5 	RCDHC-212 	2SA933SQSTA 2SC1740SQSTA DTA114ESTP DTA124ESTP DTC124ESTP 	2SA1309QRSTA 2SC3311QRSTA 2SD1450RSTA 		
2SD2037EFTA 	2SB1238QSTV6 2SD1862-P 	1SS254TA 	1D3-E 	MA4035MTA MA4056MTA MA4082MTA 	
MA4035MTA 	SLR-305LC 				

- NOTES:
 BLK Black
 BLU Blue
 BRN Brown
 GRN Green
 L.BLU... Light Blue
 ORG Orange
 PNK Pink
 RED Red
 SLD Shield Wire
 VLT Violet
 WHT White
 YEL Yellow

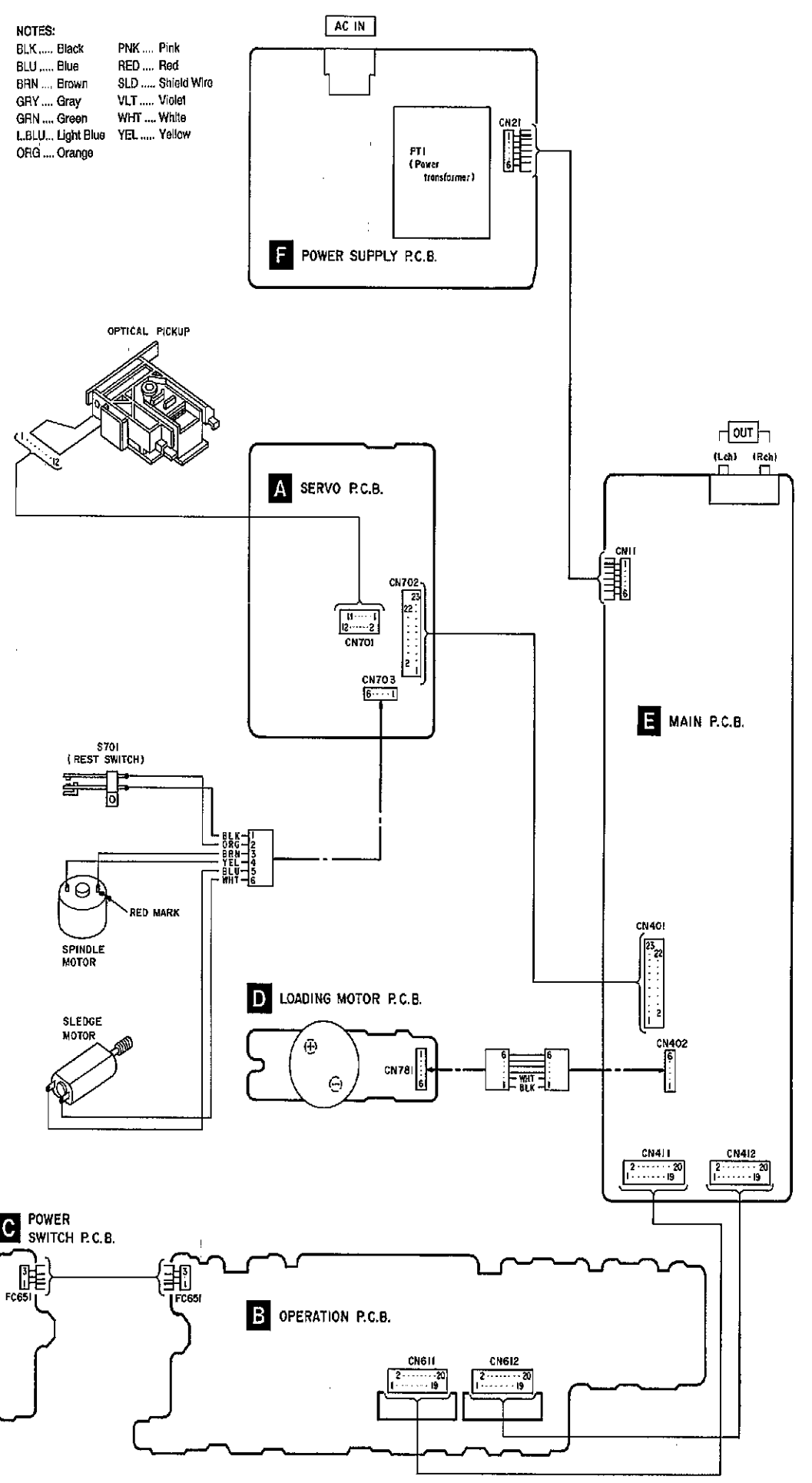

Display Function of Automatically-Adjusted Results

(Self-Check Function)

The unit contains a function which displays the result of the automatically adjustment of the servo circuits (tracking, focus servo, etc.) as an error code on the FL display. The error code display serves as a repair guide showing the automatically adjustment circuit is at fault. The procedures for displaying the error codes are given below.

Procedures to display the error code

- Procedure to display the error code before disassembly (finished unit)
 - When the [POWER] key is pressed while holding down the [STOP] [PAUSE] and [PLAY] keys simultaneously, the FL display illuminates, release the power turns on.
 - When the FL display illuminates, release the [STOP] [PAUSE] and [PLAY] keys.
 - Press the [OPEN/CLOSE] key to open the disc tray and load the test disc (SZZP1054C).
 - Press the [PLAY] key to start the play operation.
 - After the time display appears, press the [STOP] key to display the error code. (e.g. E-0)
 - The error code display can be used as a repair guide showing which servo circuit is at fault. (See Error Code Based Troubleshooting.)

Error code based troubleshooting

- ※ The unit is satisfactory if the error code is E-0 of E-2.
- ※ Before testing, check that the test disc is free of scratches and dirt and optical pickup is clean.

FL error code display	Symptom	Probable cause	Signal to check		Normal the values of voltage and waveform	
			Signal name	Location	PLAY	STOP
E-1	Focus and tracking offset adjustments did not complete in the specified time period.	① Clocks X1 and X2, power supply VDD, and reset/RST, all on IC702 ② MDATA, MCLK, MLD, and SENSE signals to/from the mechanism controller	MDATA	IC702 ⑩ pin		4.8V
			MCLK	IC702 ⑪ pin		4.8V
			MLD	IC702 ⑫ pin		4.8V
			SENSE	IC702 ⑬ pin	0V	0V
			/RST	IC702 ⑭ pin	4.9V	4.9V
			X1	IC702 ⑮ pin		
E-3 E-5 E-7 E-9 E-B E-D E-F	Disc play unstable	① Scratches or contaminants on disc surface ② Focus and tracking servo circuits (check waveforms, voltages, and part constants.) ③ Spindle driver circuit ④ Optical pickup	FE	IC702 ⑯ pin		2.4V
			TE	IC702 ⑰ pin		2.4V
			FOD	IC702 ⑱ pin	2.4V	2.4V
			TRD	IC702 ⑲ pin	2.4V	2.4V
			KICK	IC702 ⑳ pin	2.4V	2.4V
			/FLOCK	IC702 ㉑ pin	0V	4.9V
			/RF DET	IC702 ㉒ pin	0V	4.8V
			RF	TJ701		3.4V
			STAT	IC702 ㉓ pin	3.5V	0V
			FBAL	IC702 ㉔ pin	2.5 ± 1.25V	2.5 ± 1.25V
E-4 E-6 E-C E-E	Best Eye (PD Balance) adjustment diode not complete in the specified time period.	① Scratches or contaminants on disc surface ② Focus and Tracking servo circuit (check waveforms, voltages, and part constants.) ③ Optical pickup	RF	TJ701		3.4V
			FE	IC702 ⑰ pin		0V
			/TLOCK	IC702 ㉕ pin	0V	0V
			OFT	IC702 ㉖ pin	0V	0V
E-8 E-A	Focus or Tracking gain adjustment did not complete in the specified time period.	① Scratches or contaminants on disc surface ② Focus and Tracking servo circuit (check waveforms, voltages, and part constants.) ③ Optical pickup	FE	IC702 ⑰ pin		2.4V
			TE	IC702 ⑰ pin		2.4V
			/TLOCK	IC702 ㉕ pin	0V	0V
			OFT	IC702 ㉖ pin	0V	0V

Digital Servo System

DIGITAL SERVO SYSTEM

This servo system has no adjustment VRs.

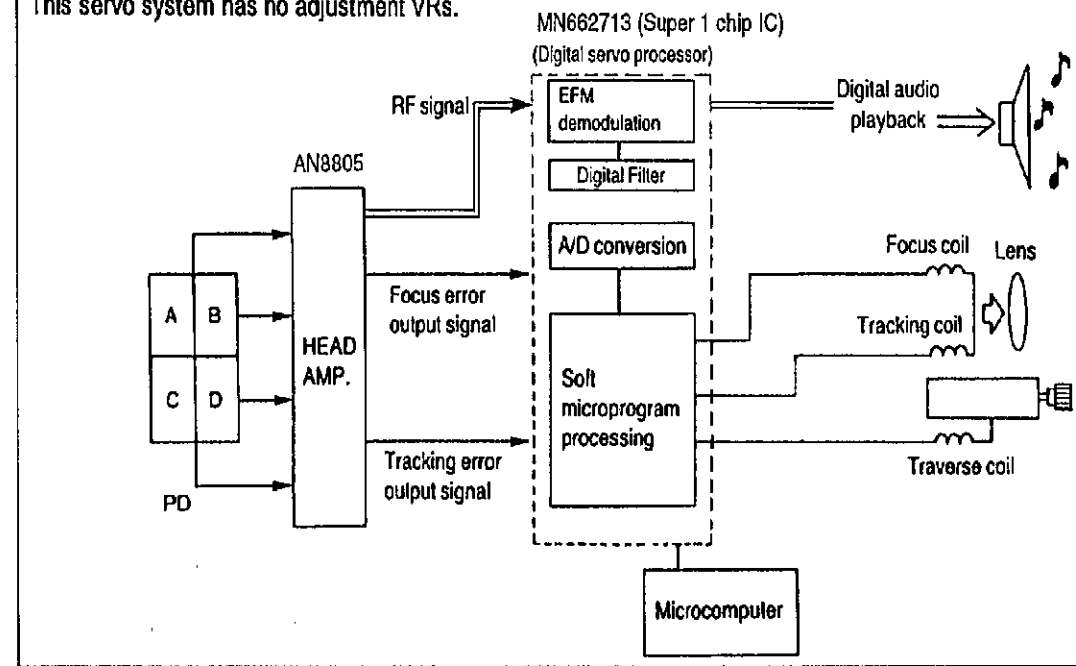

The following flow chart shows the sequence of automatic adjustments.

Flow chart on automatic adjustment sequence

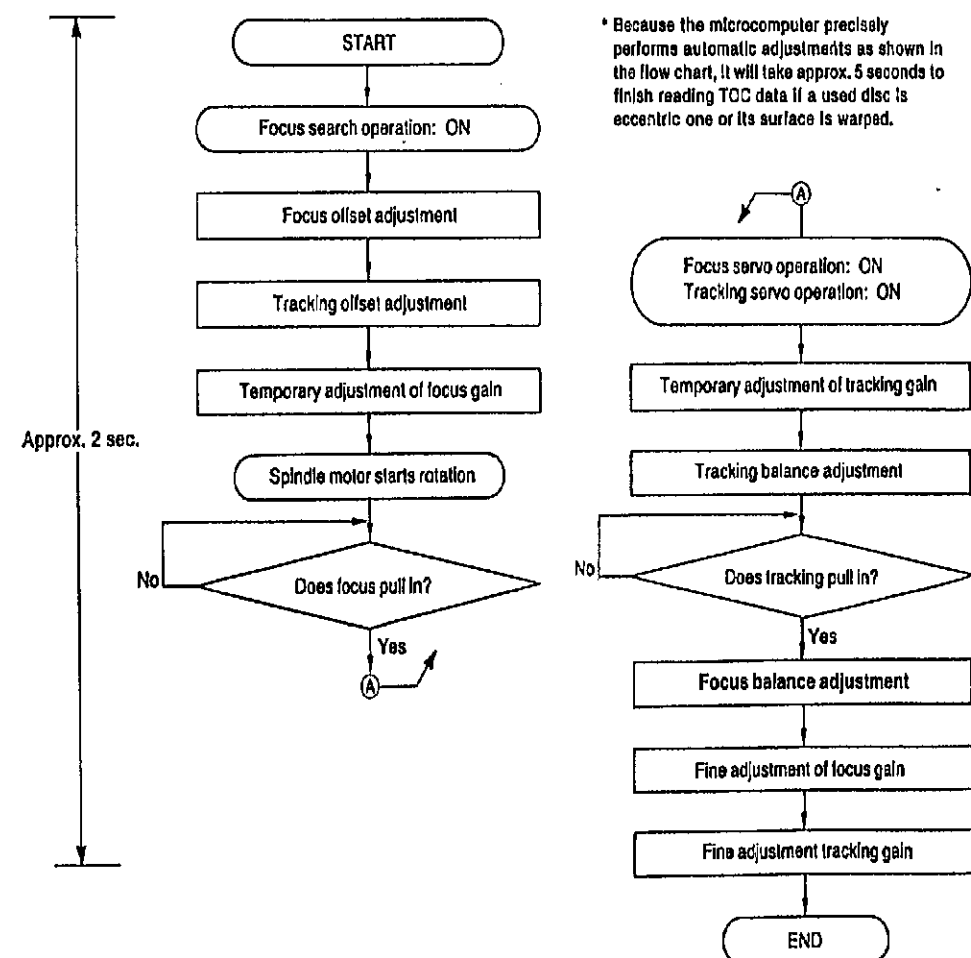

Troubleshooting Guide

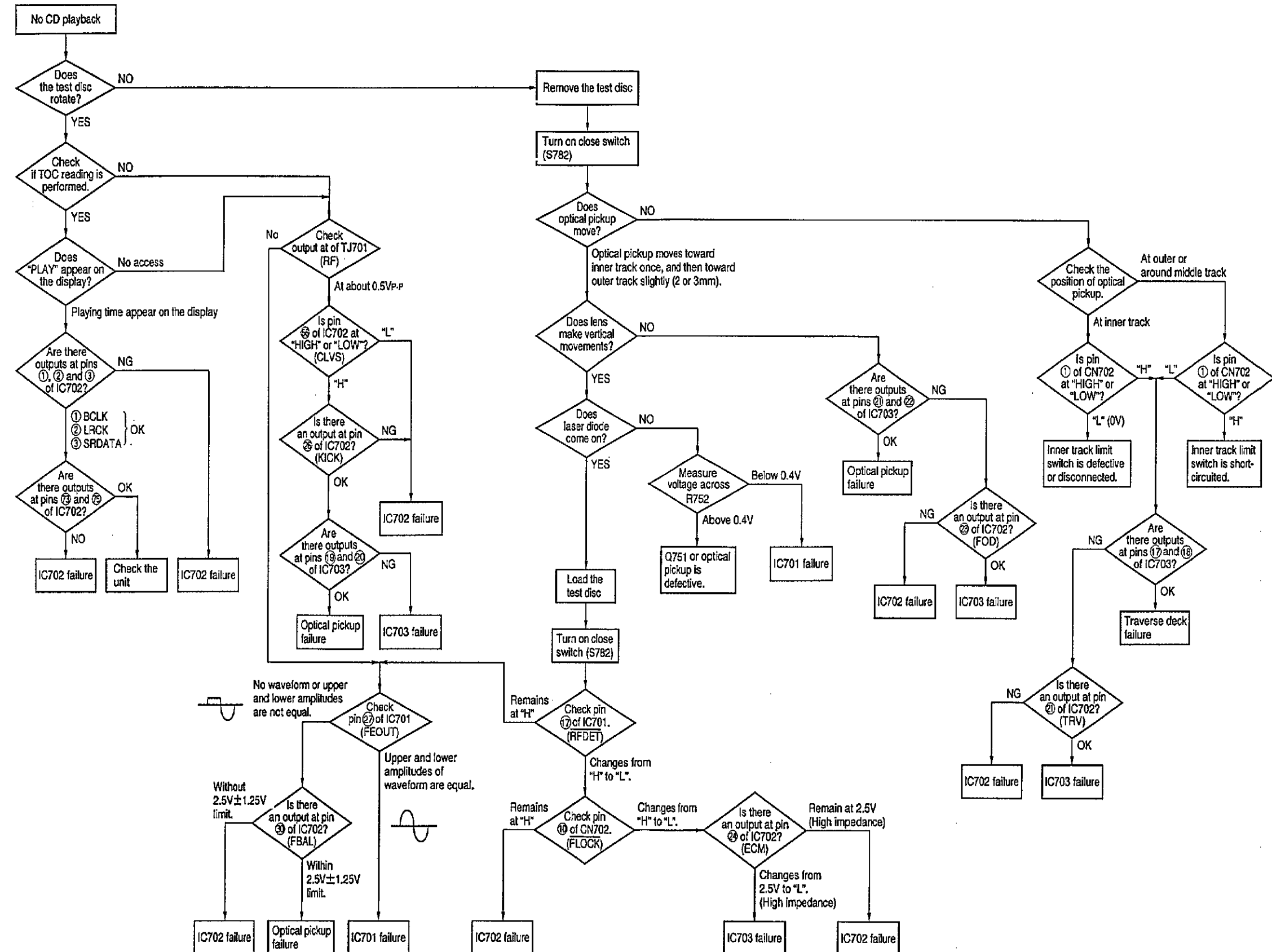



■Function of IC Terminals

●IC401 (UPD78042G063)

Pin No.	Terminal Name	I/O	Function
1	7G	○	FL grid drive signal output
7	1G	○	FL grid drive signal output
8	VDD	—	Power supply
9	MCLK	○	Microprocessor command clock
10	MDATA	○	Microprocessor command data
11	POWER SW	I	Power key switch signal input
12	SYNC REC	○	Synchro REC signal output
13	/MLD	○	Microprocessor command load signal
14	SQCK	○	External clock for subcode Q register
15	NC	—	No used, open
16	SUBQ	I	Subcode Q input
17	RST	I	Reset signal input
18	/OPEN SW	I	Disc tray "open" sense switch status
19	/CLOSE SW	I	Disc tray "close" sense switch status
20	GND	—	GND
21	/OPEN	○	Open Disc Tray command output
22	/CLOSE	○	Close Disc Tray command output
23	REST SW	I	Innermost track sense switch status
24	/RST	○	Reset signal output
25	STAT	I	Status signal input
26	/TLOCK	I	Tracking servo pull-in signal
27	/FLOCK	I	Focus servo pull-in signal
28	SENSE	I	Sense signal input
29	AVDD	—	Power supply (for A/D convert)
30	GND	—	GND
31	GND	—	GND
32	NC	—	No used, open
33	GND	—	GND
34	X1	I	Main clock (4.2336 MHz) input
35	X2	○	Main clock output

●IC703 (AN8389SE1)

Pin No.	Terminal Name	I/O	Function
1	Vcc	—	Power supply
2	VREF	I	VREF input
3	IN4	I	Motor driver (4) input
4	IN3	I	Motor driver (3) input
5	GND	—	Ground connection
6	NC	—	Ground connection
7	NRESET	—	Reset input (no used, open)
8	GND	—	Ground connection
9	IN2	I	Motor driver (2) input
10	PC2	I	PC2 (power cut) input
11	IN1	I	Motor driver (1) input
12	PC1	I	PC1 (power cut) input

Pin No.	Terminal Name	I/O	Function
36	P37	I	No used, open
36	P36	I	No used, open
39	P34	I	No used, open
40	P33	I	GND
41	P32	I	No used, open
42	P31	I	No used, open
43	P30	I	No used, open
44	MRST	○	Reset signal for MASH (No used, open)
45	EMPH	○	Emphasis signal (No used, open)
46	/DMUTE	○	Muting signal output
47	REMOCON	I	Remote control signal input
48	GND	—	GND
49	/POWER OFF	○	Power key switch signal output
50	/STANDBY LED	○	STANDBY LED control signal
51	REC ENABLE	I	REC control signal
52	VDD	—	Power supply
53	P127	I	Key return signal
57	P123	I	Key return signal
58	12G	I	Connect FL Display 12G
59	P16	○	FL anode drive signal
60	P15	○	FL anode drive signal
61	P14	○	FL anode drive signal and key scan signal
68	P7	○	FL anode drive signal
69	P6	○	FL anode drive signal
70	P5	○	FL anode drive signal
71	VPP	—	Power supply terminal for FL drive
72	P4	○	FL anode drive signal
75	P1	○	FL anode drive signal
76	12G	I	FL grid drive signal
80	8G	○	FL grid drive signal

Pin No.	Terminal Name	I/O	Function
13	PVcc1	—	Power supply (1) for driver
14	PGND1	—	Ground connection (1) for driver
15	D1-	○	Motor driver (1) reverse-action output
16	D1+	○	Motor driver (1) forward-action output
17	D2-	○	Motor driver (2) reverse-action output
18	D2+	○	Motor driver (2) forward-action output
19	D3-	○	Motor driver (3) reverse-action output
20	D3+	○	Motor driver (3) forward-action output
21	D4-	○	Motor driver (4) reverse-action output
22	D4+	○	Motor driver (4) forward-action output
23	PGND2	—	Ground connection (2) for driver
24	PVcc2	—	Power supply (2) for driver

●IC701 (AN8805SBE1)

Pin No.	Terminal Name	I/O	Function
1	PD	I	APC amplifier input
2	LD	○	APC amplifier output (No used, open)
3	LD ON/OFF	I	APC ON/OFF control signal
4	REFSW	I	Capacitor connection for CROSS
5	VCC	—	Power supply
6	RF-	I	RF amplifier inversion signal input
7	RF	○	RF amplifier signal output
8	RFIN	I	AGC signal input
9	CAGC	I	AGC loop filter connection
10	ARF	○	AGC signal output
11	CENV	I	Capacitor connection for RF detection
12	CEA	I	Capacitor connection for HPF amplifier
13	CSBDO	I	Capacitor connection for -RF envelope detection
14	EDO	○	BDO signal output
15	CSBRT	I	Capacitor connection for RF envelope detection
16	OFTR	○	OFTR signal output
17	/RFDET	○	RFDET signal output
18	Vss	—	GND
19	ENV	○	3TENV signal output
20	VREF	○	VREF signal output
21	LD OFF	—	APC OFF signal control
22	VDET	○	VDET signal output
23	TEBPF	I	VDET signal input
24	CROSS	○	CROSS signal output
25	TEOUT	○	TE amplifier signal output
26	TE-	I	TE amplifier inversion signal input
27	FEOUT	○	FE amplifier signal output
28	FE-	I	FE amplifier inversion signal input
29	FBAL	I	F BAL control signal
30	TBAL	I	T BAL control signal
31	PDFR	—	Adjustment for I-V amplifier conversion resistor
32	PDER	—	Adjustment for I-V amplifier conversion resistor
33	E	I	I-V amplifier signal input
34	F	I	I-V amplifier signal input
35	B+D	I	I-V amplifier signal input
36	A+C	I	I-V amplifier signal input

●IC702 (MN662713RG1)

Pin No.	Terminal Name	I/O	Function
1	BCLK	○	Bit clock output for serial data
2	LACK	—	L.R identification signal output
3	SRDATA	—	Serial data output
4	DVdd1	—	Power supply input (for digital circuit)
5	DVss1	—	GND (for digital circuit)
6	TX	○	Digital audio interface signal output
7	MCLK	I	Microprocessor command clock signal input (Latches data at first transition)
8	MDATA	I	Microprocessor command data signal input
9	MLD	I	Microprocessor command load signal input
10	SENSE	○	Sense signal output (OFT, FESL, MAGEND, NAJEND, POSAD, SFG)
11	/FLOCK	○	Focus servo feeding signal output ("L": Feed)
12	/TLOCK	○	Tracking servo feeding signal output ("L": Feed)
13	BLKCK	○	Sub-code block clock signal output (BLKCK = 75 Hz during normal playback) (no used, open)
14	SQCK	I	External clock signal input for sub-code Q register
15	SUBQ	○	Sub-code Q code output
16	DMUTE	I	Muting input ("H": Mute)
17	STAT	○	Status signal output (CRC, CUE, CLVS, TTSTVP, FCLV, SQCK)
18	/RST	I	Reset input
19	SMCK	—	1/2-divided clock signal of crystal oscillating at MSEL = "H" (SMCK = 8.4672 MHz)
20	PMCK	—	1/192-divided clock signal of crystal oscillating (PMCK = 88.2 kHz) (no used, open)
21	TRV	○	Traverse forced feed output
22	TVD	○	Traverse drive output
23	PC	○	Spindle motor ON signal output ("L": ON)
24	ECM	○	Spindle motor drive signal output (forced mode output)
25	ECS	○	Spindle motor drive signal output (servo error signal output)
26	KICK	○	Kick pulse output
27	TRD	○	Tracking drive output
28	FOD	○	Focus drive output
29	VREF	I	D/A (drive) output (TVD, ECS, TRD, FOD, FBAL, TBAL) reference voltage input
30	FBAL	○	Focus balance adjustment output
31	TBAL	○	Tracking balance adjustment output

●IC702 Continued

Pin No.	Terminal Name	I/O	Function
32	FE	I	Focus error signal input (analog input)
33	TE	I	Tracking error signal input (analog input)
34	RFENV	I	RF envelope signal input
35	VDET	I	Vibration detection signal input ("H": detection)
36	OFT	I	Off-track signal input ("H": off track)
37	TRCRS	I	Track cross signal input
38	/RFDET	I	RF detection signal input ("L": detection)
39	BDO	I	Dropout signal input ("H": Dropout)
40	LDON	○	Laser on signal output ("H": ON)
41	TES	○	Tracking error shunt signal output ("H": shunt) (no used, open)
42	PLAY	○	Play signal output ("H": PLAY) (no used, open)
43	WVEL	○	Double speed status signal output ("H": Double speed) (no used, open)
44	ARF	I	RF signal input
45	IREF	I	Reference current input
46	DRF	—	DSL bias (no used, open)
47	DSLIF	I/O	DSL loop filter
48	PLL	I/O	PLL loop filter
49	VCOF	I/O	VCO loop filter
50	AVdd2	—	Power supply input (for analog circuit)
51	AVss2	—	GND (for analog circuit)
52	EFM	—	EFM signal output (not used, open)
53	PCK	—	PLL extraction clock output (PCK = 4.321 MHz during normal playback) (no used, open)
54	PDO	—	Phase comparison signal of EFM and PCK signals (no used, open)
55	SUBC	○	Sub-code serial data output (no used, open)
56	SBCK	I	Clock input for sub-code serial data
57	Vss	—	GND
58	X1	I	Crystal oscillating circuit input (f = 16.9344 MHz)
59	X2	○	Crystal oscillating circuit output (f = 16.9344 MHz)
60	Vdd	—	Power supply input (for oscillating circuit)
61	BYTCK	—	Byte clock output (no used, open)
62	/CLDCK	○	Sub-code frame clock signal output (CLDCK = 7.35 kHz during normal playback)
63	FCLK	—	Crystal frame clock signal output (FCLK = 7.35 kHz, double = 14.7 kHz)
64	IPFLAG	○	Interpolation flag output ("H": Interpolation) (no used, open)
65	FLAG	○	Flag output (no used, open)

Pin No.	Terminal Name	I/O	Function
66	CLVS	○	Spindle servo phase synchronizing signal output ("H": CLV, "L": rough servo) (no used, open)
67	CRC	○	Sub-code CRC checked output ("H": OK, "L": NG) (no used, open)
68	DEMPH	○	De-emphasis ON signal output ("H": ON) (no used, open)
69	RESY	—	Frame resynchronizing signal output (no used, open)
70	/RST2	I	Reset input through MASH circuit ("L": Reset)
71	/TEST	I	Test input
72	AVdd1	—	Power supply input (for analog circuit)
73	CUTL	○	Left channel audio signal output
74	AVss1	—	GND
75	OUTR	○	Right channel audio signal output
76	RSEL	I	RF signal polarity assignment input (at "H" level: RSEL = "H", at "L" level: RSEL = "L")
77	CSEL	I	Crystal oscillating frequency designation input ("H": 16.9344 MHz, "H": 33.8688 MHz)
78	PSEL	I	Test input (normally, "L")
79	MSEL	I	Output frequency switching for SMCK terminal "H": SMCK = 8.4672 MHz "L": SMCK = 4.2336 MHz
80	SSEL	I	Output mode switching of SUBQ terminal ("H": Q code buffer mode)

■Replacement Parts List

Notes: *Important safety notice:
 Components identified by Δ mark have special characteristics important for safety. Furthermore, special parts which have purposes of fire-retardant (resistors), high-quality sound (capacitors), low-noise (resistors), etc. are used.
 When replacing any of components, be sure to use only manufacturer's specified parts shown in the parts list.
 *The parenthesized indications in the Remarks column specify the areas. (Refer to the cover page for area.)
 Parts without these indications can be used for all areas.
 (MB) Indicates in Remarks column parts that are supplied by MBV.
 *Warning: This product uses a laser diode. Refer to caution statements on page 2.
 *ACHTUNG: Die Laserinheit darf nur gegen eine vom Hersteller spezifizierte Einheit ausgetauscht werden.
 *The "(SF)" mark denotes the standard part.

Ref. No.	Part No.	Part Name & Description	Remarks	Ref. No.	Part No.	Part Name & Description	Remarks
				D052	1S8254TA	DIODE	
						TRANSFORMER(S)	
						POWER TRANSFORMER	Δ (MB)
						OSCILLATOR(S)	
IC11	LM2940TS	I. C. REGULATOR	Δ			OSCILLATOR (4.23MHz)	
IC401	UPD78042G063	I. C. SYSTEM CONTROL	(MB)	PT1	RTP1K48020	POWER TRANSFORMER	Δ (MB)
IC601	RCMHC-212	I. C. BEARBEIT. SENSOR	(MB)			OSCILLATOR (16.9MHz)	
IC701	AN8805SBE1	I. C. SERVO AMP.	(MB)			OSCILLATOR (16.9MHz)	
IC702	MN662713RG1	I. C. SERVO PROCESSOR	(MB)			DISPLAY TUBE	
IC703	AN8389SE1	I. C. MOTOR DRIVE	(MB)	X401	RSX1442001LT	OSCILLATOR (4.23MHz)	
IC701	TA7291SA	I. C. MOTOR DRIVE	(MB)	X701	RSX2169001LT	OSCILLATOR (16.9MHz)	
IC802, 803	BA4560FEI	I. C. DIFFERENTIAL P. F. AMP	(MB)			DISPLAY TUBE	
						TRANSISTOR(S)	
				FL601	RS10169-F	DISPLAY TUBE	(MB)
Q11	2SD2037EFA	TRANSISTOR	Δ			SWITCHES	
Q12	2SC3311A-Q	TRANSISTOR	Δ			SW. 0	
Q13-14	2SA1309A-R	TRANSISTOR	Δ	S801	EVQ21405R	SW. 1	
Q15	2SA1308A-R	TRANSISTOR	Δ	S802	EVQ21405R	SW. 2	
Q19, 20	2SD1450HTA	TRANSISTOR	Δ	S803	EVQ21405R	SW. 3	
Q21	D7A124ESTP	TRANSISTOR	Δ	S804	EVQ21405R	SW. 4	
Q22	2SC2711A-Q	TRANSISTOR	Δ	S805	EVQ21405R	SW. 5	
Q23	2SD2037EFA	TRANSISTOR	Δ	S806	EVQ21405R	SW. 6	
Q51, 52	2SC3311A-Q	TRANSISTOR	Δ	S807	EVQ21405R	SW. 7	
Q61, 402	2SD1862-P	TRANSISTOR	Δ	S808	EVQ21405R	SW. 10	
Q751	2SA933SR	TRANSISTOR	Δ	S809	EVQ21405R	SW. 9	
Q752	2SC1740SR	TRANSISTOR	Δ	S810	EVQ21405R	SW. 8	
Q803, 804	2SD1450HTA	TRANSISTOR	Δ	S811	EVQ21405R	SW. 7	
Q851	D7A124ESTP	TRANSISTOR	Δ	S812	EVQ21405R	SW. 6	
Q853	D7A124ESTP	TRANSISTOR	Δ	S813	EVQ21405R	SW. PLAY	
				S814	EVQ21405R	SW. R. SKIP	
				S815	EVQ21405R	SW. F. SERACH	
				S816	EVQ21405R	SW. PROGRAM	
D11-18	1D3-E	DIODE	Δ (MB)	S817	EVQ21405R	SW. DISC LINK	
D19	MA4330MTA	DIODE	Δ	S819	EVQ21405R	SW. STOP	
D20	1S8254TA	DIODE	Δ	S820	EVQ21405R	SW. F. SKIP	
D21, 22	MA4082MTA	DIODE	Δ	S821	EVQ21405R	SW. F. SERACH	
D25, 26	1S8254TA	DIODE	Δ	S822	EVQ21405R	SW. RECALL	
D51	MA4039MTA	DIODE	Δ	S823	EVQ21405R	SW. SIDE A/B	
D401	MA4059MTA	DIODE	Δ	S824	EVQ21405R	SW. RANDOM	
D601-607	1S8254TA	DIODE	Δ	S825	EVQ21405R	SW. TIME FADE	
D651	S1A-3051C	LED	Δ	S826	EVQ21405R	SW. OPEN/CLOSE	
D701	1S8254TA	DIODE	Δ	S827	EVQ21405R	SW. PAUSE	
D801, 802	1S8254TA	DIODE	Δ	S828	EVQ21405R	SW. REPEAT	
D851	1D3-E	DIODE	(MB)	S829	EVQ21405R	SW. CLEAR	

■ Cabinet Parts Location

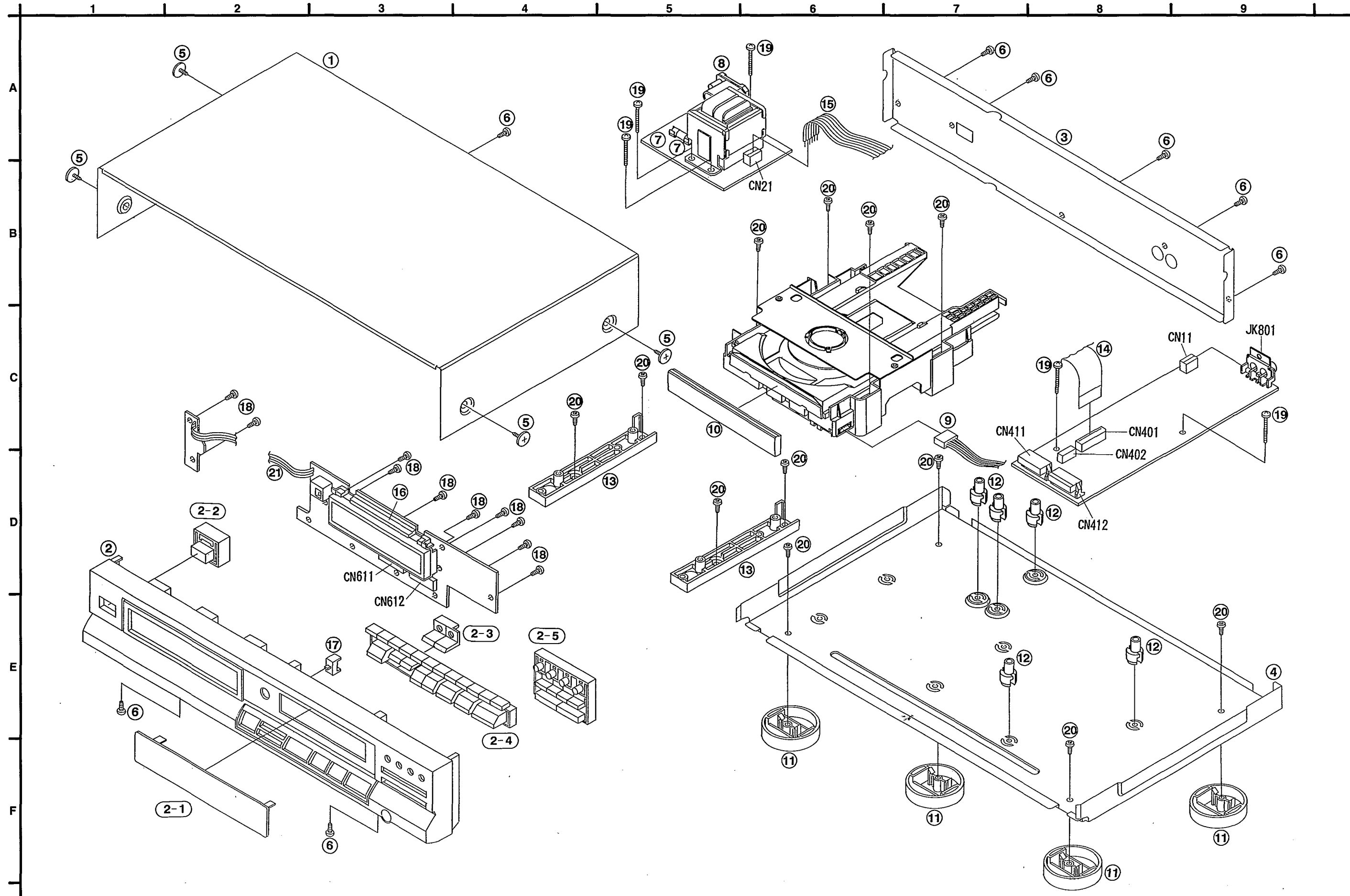

■ Loading Unit Parts Location

Note:

When changing mechanism parts, apply the specified grease to areas marked "xx" as shown in the drawing.

Ref No.	Part No.
①	RFKXEM30L

A

B

C

D

E

F

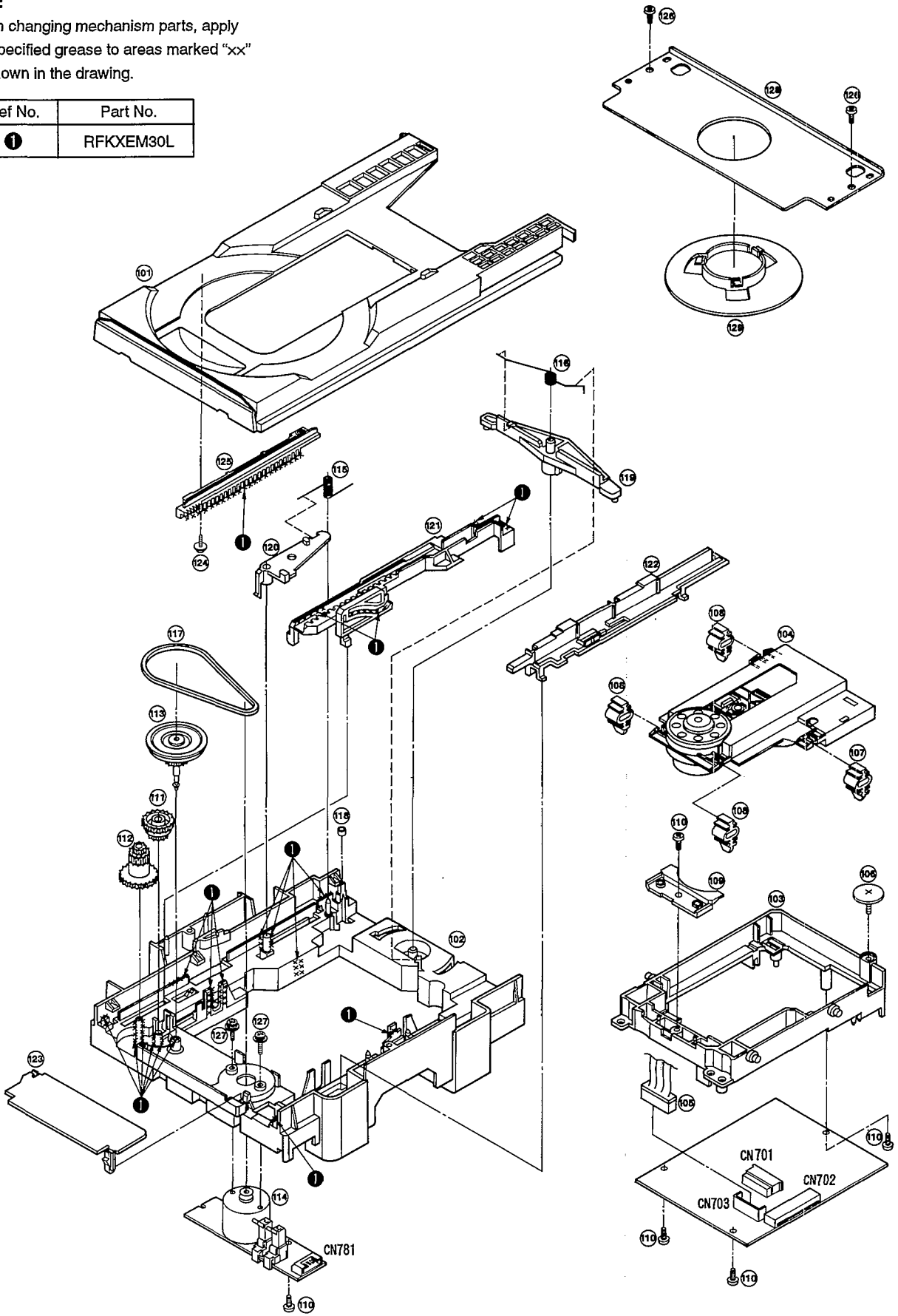

Ref. No.	Part No.	Part Name & Description	Remarks
		CABINET PARTS	
1	RKM0098-K	CABINET	[MB]
2	RFKGLPG360AE	FRONT PANEL ASS'Y	[MB]
2-1	RKWO245D-R	WINDOW	[MB]
2-2	RGU1029-K	POWER BUTTON	[MB]
2-3	RFKNLPG460AD	MAIN BUTTON A	[MB]
2-4	RFKNLPG460AE	MAIN BUTTON B	[MB]
2-5	RGU0808-K	SUB BUTTON	[MB]
3	RFKHLPG360AE	REAR PANEL ASS'Y	[MB] (E) (EG)
3	RFKHLPG360AB	REAR PANEL ASS'Y	[MB] (EB)
4	RMK0178-1	BOTTOM CHASSIS	[MB]
5	RHD30035-K	SCREW	
6	XTBS3+8JFZ1	SCREW	
7	EYF52BC	FUSE HOLDER	
8	SJS9236	AC INLET (JK1)	△
9	REX0577	CABLE ASS'Y	[MB]
10	RGK0616-K	TRAY LID	[MB]
11	RKA0040B	FOOT	[MB]
12	RMRO377-1	PCB SUPPORT	[MB]
13	RMRO718-W	MECHANISM SPACER	[MB]
14	RWJ5223180EE	FPC	[MB]
15	RWJ6406180XX	FLAT CABLE	[MB]
16	RMRO659-K	FL HOLDER	[MB]
17	RGL0228-Q	LED INDICATOR	[MB]
18	XTBS26+8J	SCREW	
19	XTB3+20JFR	SCREW	
20	XTB3+8JFZ	SCREW	
21	RWJ6403200XX	FLAT CABLE (FC651)	[MB]
		LOADING UNIT PARTS	
101	RGQ0130-K	TRAY	[MB]
102	RFKJLPG460AE	MECHANISM CHASSIS ASS'Y	[MB]
103	RMRO719-W	MID, CHASSIS	[MB]
104	RAE1100Z	TRAVERSE UNIT	[MB]
105	REX0576	CABLE ASS'Y	[MB]
106	RHD30047	SCREW	[MB]
107	RMGO337-K	DAMPING RUBBER	[MB]
108	RMGO337-Q	DAMPING RUBBER	[MB]
109	RMRO750-W	STOPPER	[MB]
110	XTBS26+8J	SCREW	
111	RDG0142	RELAY GEAR	
112	RDG0259	DRIVE GEAR	[MB]
113	RDPO065	RELAY PULLY	
114	REM0047	MOTOR ASS'Y	[MB]
115	RME0063	LOCK LEVER SPRING	
116	RME0087	ASSIST SPRING	
117	RMGO158	BELT	
118	RMGO338-Q	STOPPER RUBBER	[MB]
119	RML0177	CHANGE LEVER	

Ref. No.	Part No.	Part Name & Description	Remarks
120	RML0178-1	LOCK LEVER	
121	RM0112	SLIDER 1	[MB]
122	RM0113	SLIDER 2	[MB]
123	RMRO721-K	GEAR COVER	[MB]
124	RHD20009-1	SCREW	
125	RFKNLPG460AA	DRIVE RACK ASS'Y	[MB]
126	XTB3+8JFZ	SCREW	
127	XYN2+F6FZ	SCREW	
128	RFKNLPG460AB	CLAMP BASE ASS'Y	[MB]
129	RFKNLPG460AC	CLAMPER ASS'Y	[MB]
		PACKING MATERIALS	
P1	RPG1906	PACKING CASE	[MB]
P2	RPNO647	CUSHION	[MB]
P3	XZB23X35C03	PROTECTION BAG	
P4	XZB60X65A01Z	PROTECTION BAG	
		ACCESSORIES	
A1	RJA0043-C	AC POWER CORD	△ (E, EG) [MB]
A1	RJA0034-P	AC POWER CORD	△ (EB) [MB]
A2	RFKSLPG360AE	INSTRUCTIONS MANUAL	(E) [MB]
A2	RQT2226-B	INSTRUCTIONS MANUAL	(EB) [MB]
A2	RFKSLPG360AG	INSTRUCTIONS MANUAL	(EG) [MB]
A3	SJP2249-3	STEREO PIN CORD	
A4	RQA0013	WARRANTY CARD	
A5	RQCB0169	SERVICE CENTER LIST	

■ Packaging

