

# Service Manual

Compact Disc Player

Compact Disc Player

## SL-PG460A

**COMPACT**  
**disc**  
**DIGITAL AUDIO**

**DIGITAL**

**MASH**  
multi-stage noise shaping

Colour

(K) . . . . Black Type

**Area**

Suffix for Model No.	Area	Colour
(E)	Europe	(K)
(EB)	Great Britain	
(EG)	Germany and Italy	

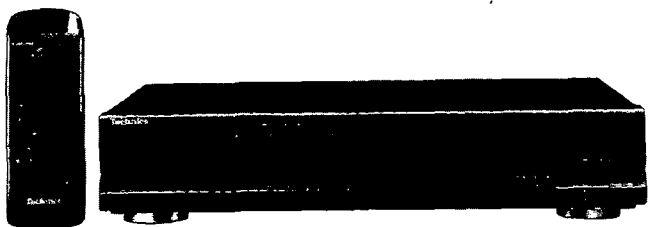

### New Traverse Deck (RAE1100Z) Specifications

■ **Audio**

No. of channels	2 (left and right, stereo)
Frequency response	2-20,000 Hz, ±0.5 dB
Output voltage	2 V (at 0 dB)
Dynamic range	96 dB
S/N	100 dB
Harmonic distortion	0.0035% (1 kHz, 0 dB)
Total harmonic distortion	0.004% (1 kHz, 0 dB)
Wow and flutter	Below measurable limit
DA converter	MASH (1 bit)
Output impedance	600Ω
Load impedance	More than 10 kΩ
Headphone output level	15 mW max. 32Ω (adjustable)

■ **Pickup**

Wavelength	780 nm
Laser Power	No hazardous radiation is emitted (with safety protection)

■ **General**

Power consumption	13 W
Power supply	AC 50/60 Hz, 230-240 V
Dimensions (W×H×D)	430×92×290 mm
Weight	3.3 kg

**Note:**

Specifications are subject to change without notice. Weight and dimensions are approximate.

**For United Kingdom only:**

This apparatus was produced to BS 800.

- Technics (or Panasonic) developed the world's first MASH type DAC and ADC. MASH technology was invented by NTT (LSI Labs).
- MASH is a trademark of NTT.

# Technics

## ■Contents

	Page		Page
●Handling Precautions for Traverse Deck .....	2	●Schematic Diagram .....	17~22
●Precaution of Laser Diode .....	2, 3	●Printed Circuit Board Diagram .....	23~25
●Accessories .....	3	●Wiring Connection Diagram .....	26
●Connections .....	3	●Display Function of	
●Caution for AC Mains Lead (For United Kingdom) .....	4	Automatically-Adjusted Results .....	27
●Location of Controls .....	5	●Digital Servo System .....	28
●Basic Operating Procedure .....	6	●Troubleshooting Guide .....	29, 30
●Disassembly Instructions .....	7~12	●Functions of IC Terminals .....	31~33
●Installing Disc Tray .....	13	●Replacement Parts List .....	34~40
●How to Check the Main P.C.B. ....	14	●Cabinet Parts Location .....	37
●How to Check the Servo P.C.B. ....	14	●Loading Unit Parts Location .....	39
●Block Diagram .....	15, 16	●Packaging .....	40

## ■Handling Precautions for Traverse Deck

The laser diode in the traverse deck (optical pickup) may break down due to potential difference caused by static electricity of clothes or human body.

So, be careful of electrostatic breakdown during repair of the traverse deck (optical pickup).

### ●Handling of traverse deck (optical pickup)

1. Do not subject the traverse deck (optical pickup) to static electricity as it is extremely sensitive to electrical shock.
2. To prevent the breakdown of the laser diode, an anti-static shorting pin is inserted into the flexible board (FPC board). When removing or connecting the short pin, finish the job in as short time as possible.
3. Take care not to apply excessive stress to the flexible board (FPC board).
4. Do not turn the variable resistor (laser power adjustment). It has already been adjusted.

### ●Grounding for electrostatic breakdown prevention

1. Human body grounding  
Use the anti-static wrist strap to discharge the static electricity from your body.
2. Work table grounding  
Put a conductive material (sheet) or steel sheet on the area where the traverse deck (optical pickup) is placed, and ground the sheet.

#### Caution:

The static electricity of your clothes will not be grounded through the wrist strap. So, take care not to let your clothes touch the traverse deck (optical pickup).

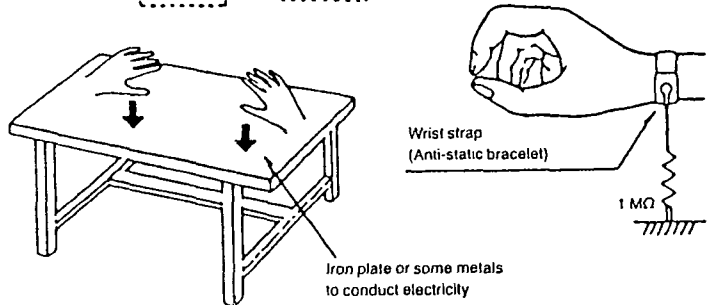
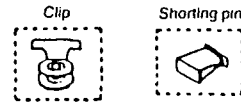
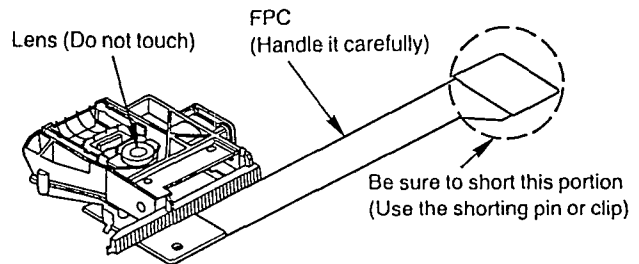

## ■Precaution of Laser Diode

**CAUTION:** This product utilizes a laser diode with the unit turned "on", invisible laser radiation is emitted from the pick up lens.  
Wave length: 780 nm  
Maximum output radiation power from pick up: 100 μW/VDE

Laser radiation from the pick up unit is safety level, but be sure the followings:

1. Do not disassemble the optical pick up unit, since radiation from exposed laser diode is dangerous.
2. Do not adjust the variable resistor on the pickup unit. It was already adjusted.
3. Do not look at the focus lens using optical instruments.
4. Recommend not to look at pick up lens for a long time.

**ACHTUNG:** Dieses produkt enthält eine laserdiode. Im eingeschalteten zustand wird unsichtbare laserstrahlung von der lasereinheit abgestrahlt.

Wellenlänge: 780 nm  
Maximale strahlungsleistung der lasereinheit: 100 μW/VDE

Die strahlung an der lasereinheit ist ungefährlich, wenn folgende punkte beachtet werden:

1. Die lasereinheit nicht zerlegen, da die strahlung an der freigelegten laserdiode gefährlich ist.
2. Den werkseitig justierten einstellregler der lasereinheit nicht verstellen.
3. Nicht mit optischen instrumenten in die fokussierlinse blicken.
4. Nicht über längere zeit in die fokussierlinse blicken.

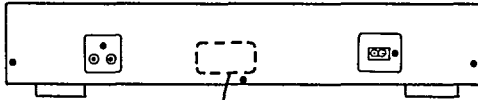

**CLASS 1  
LASER PRODUCT**

**LUOKAN 1 LASERLAITE  
KLASS 1 LASER APPARAT**

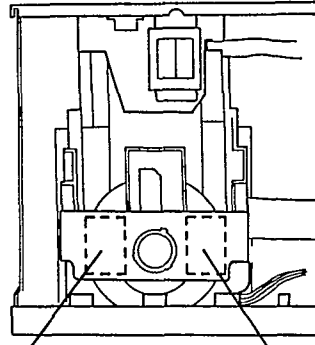

<b>VARO!</b> Avattaessa ja suojalukitus ohitettaessa olet alttiina näkymätön laseräätilylle. Älä katso säteeseen.	<b>ADVERSE!</b> Usynlig laserstråling når deksel åpnes og sikkerhetslås brytes. Unngå eksponering for strålen.
<b>VARNING!</b> Osynlig laserstråling når denna del är öppnad och spårren är urkopplad. Betrakta ej strålen.	<b>VORSICHT - Unsichtbare</b> Laserstrahlung, wenn Abdeckung geöffnet. Nicht dem Strahl aussetzen.

**ADVARSEL: USYNLIG LASERSTRÅLING VED ÅBNING, NÅR SIKKERHEDSAF-BRYDERE ER UDE AF FUNKTION. UNDGÅ UDSÆTTELSE FOR STRÅLING.**

**DANGER-invisible laser radiation when open. AVOID DIRECT EXPOSURE TO BEAM.**

**Accessories**

- AC mains lead ..... 1 pc.  
(For United Kingdom: RJA0034-P) (For others: RJA0043-C)

- Remote control ..... 1 pc.  
(EUR642100)

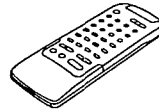
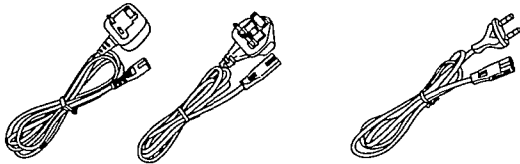

- Stereo connection cable ..... 1 pc.  
(SJP2249-3)

- Batteries for remote control ..... 2 pcs.  
(UM-4, AAA, R03)

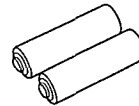
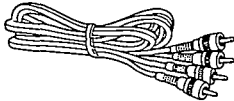

**Connections**

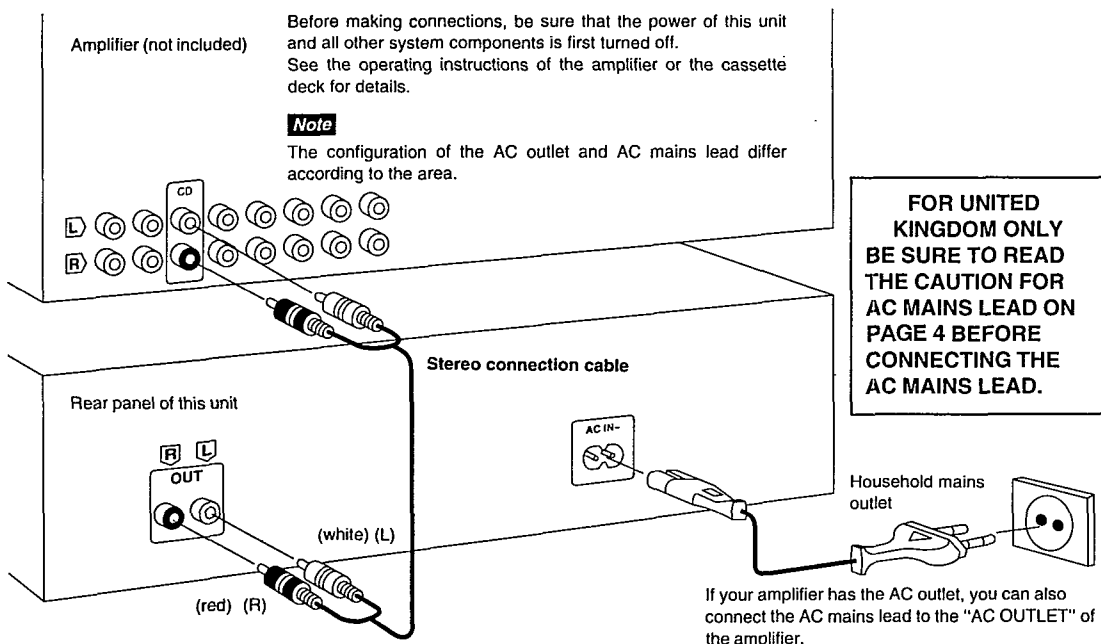

## ■ Caution for AC Mains Lead (For United Kingdom)

("EB" area code model only)

For your safety, please read the following text carefully.

This appliance is supplied with a moulded three pin mains plug for your safety and convenience.

A 5-ampere fuse is fitted in this plug.

Should the fuse need to be replaced please ensure that the replacement fuse has a rating of 5-ampere and that it is approved by ASTA or BSI to BS1362.

Check for the ASTA mark  or the BSI mark  on the body of the fuse.

If the plug contains a removable fuse cover you must ensure that it is refitted when the fuse is replaced.

If you lose the fuse cover the plug must not be used until a replacement cover is obtained.

A replacement fuse cover can be purchased from your local dealer.

### CAUTION!

IF THE FITTED MOULDED PLUG IS UNSUITABLE FOR THE SOCKET OUTLET IN YOUR HOME THEN THE FUSE SHOULD BE REMOVED AND THE PLUG CUT OFF AND DISPOSED OF SAFELY.

THERE IS A DANGER OF SEVERE ELECTRICAL SHOCK IF THE CUT OFF PLUG IS INSERTED INTO ANY 13-AMPERE SOCKET.

If a new plug is to be fitted please observe the wiring code as shown below.

If in any doubt please consult a qualified electrician.

### IMPORTANT

If the socket outlets in the home are not suitable for the plug supplied with this appliance it should be cut off and an appropriate three pin plug fitted.

The wires in this mains lead are coloured in accordance with the following code:

Blue: Neutral

Brown: Live

Do not connect either wire to the earth terminal in the plug which is marked by the letter "E" or by the safety earth symbol  or coloured green or green-and-yellow.

As the colours of the wires in the mains lead of this apparatus may not correspond with the coloured markings identifying the terminals in your plug proceed as follows. The wire which is coloured BLUE must be connected to the terminal which is marked with the letter N or coloured BLACK.

The wire which is coloured BROWN must be connected to the terminal which is marked with the letter L or coloured RED.

### Before use

Remove the connector cover as follows.

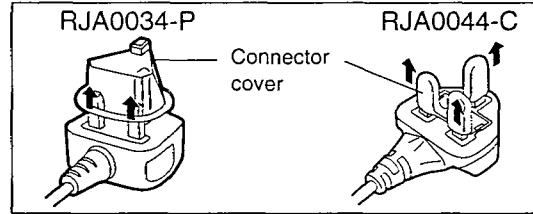

### How to replace the fuse

1. Open the fuse cover with a screwdriver.

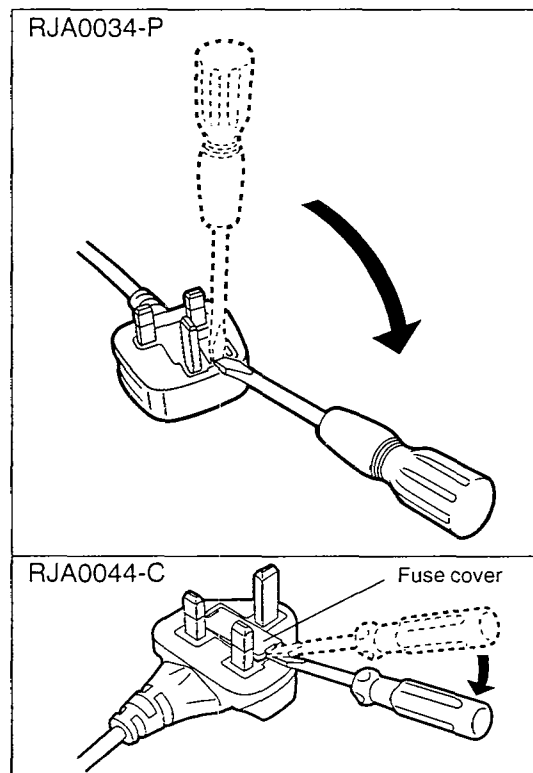

2. Replace the fuse and close or attach the fuse cover.

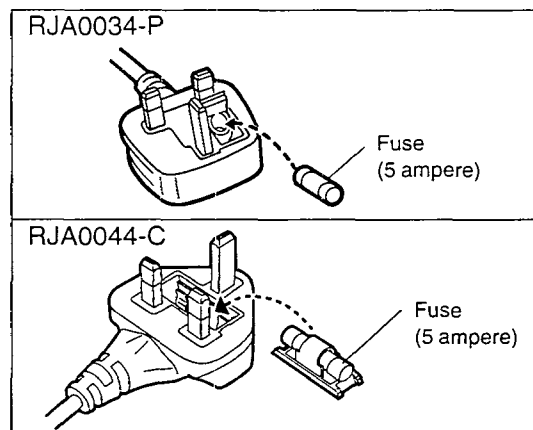

## ■ Location of Controls

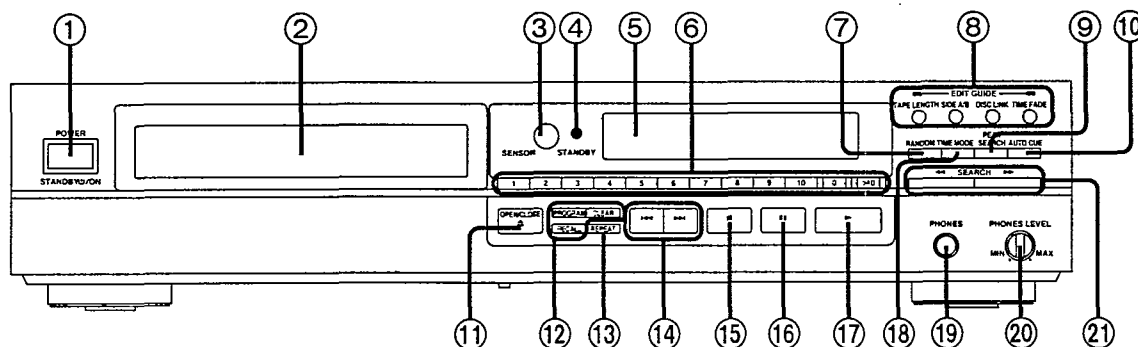

No.	Name
①	<b>Power “STANDBY <math>\odot</math>/ON” switch (POWER, STANDBY <math>\odot</math>/ON)</b> Press to switch the unit from on to standby mode or vice versa. In standby mode, the unit is still consuming a small amount of power.
②	<b>Disc tray</b>
③	<b>Remote control signal sensor (SENSOR)</b>
④	<b>Standby indicator (STANDBY)</b>
⑤	<b>Display panel</b>
⑥	<b>Numeric buttons (1-10, 0, &gt;10)</b>
⑦	<b>Random play button (RANDOM)</b>
⑧	<b>CD edit record buttons (EDIT GUIDE)</b> <ul style="list-style-type: none"> <li>•Tape length button (TAPE LENGTH)</li> <li>•Tape side switch button (SIDE A/B)</li> <li>•Disc link button (DISC LINK)</li> <li>•Time fade button (TIME FADE)</li> </ul>
⑨	<b>Peak search button (PEAK SEARCH)</b>
⑩	<b>Auto cue button (AUTO CUE)</b>

No.	Name
⑪	<b>Disc tray open/close button (<math>\blacktriangle</math> OPEN/CLOSE)</b>
⑫	<b>Program play buttons</b> <ul style="list-style-type: none"> <li>•Program button (PROGRAM)</li> <li>•Clear button (CLEAR)</li> <li>•Recall button (RECALL)</li> </ul>
⑬	<b>Repeat button (REPEAT)</b>
⑭	<b>Skip buttons (<math>\blacktriangleleft</math>, <math>\blacktriangleright</math>)</b>
⑮	<b>Stop button (<math>\blacksquare</math>)</b>
⑯	<b>Pause button (<math>\parallel</math>)</b>
⑰	<b>Play button (<math>\blacktriangleright</math>)</b>
⑱	<b>Time mode select button (TIME MODE)</b>
⑲	<b>Headphones jack (PHONES)</b>
⑳	<b>Headphones volume level knob (PHONES LEVEL)</b>
㉑	<b>Search buttons (<math>\blacktriangleleft</math> SEARCH <math>\blacktriangleright</math>)</b>

# Basic Operating Procedure

With this function, a disc is played from the first track to the last track and then stops automatically.

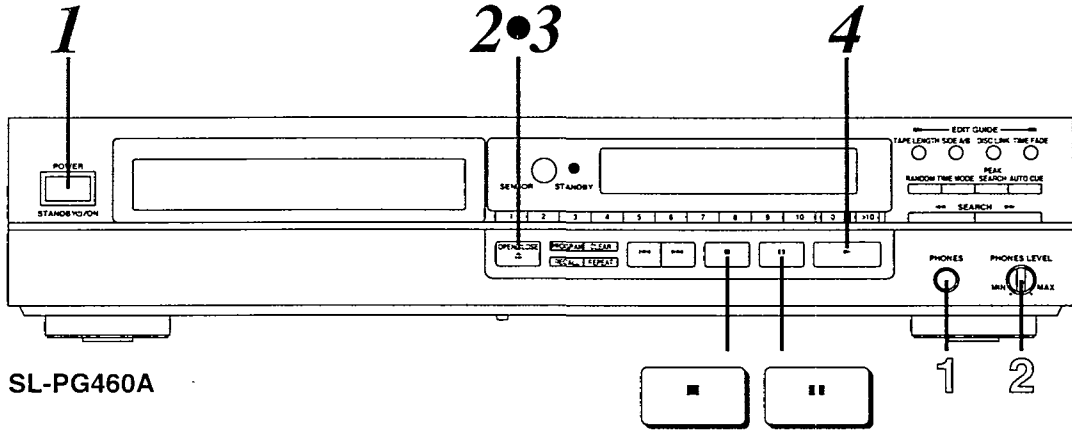

**1** Press **POWER** (Power goes on).  
If a compact disc is already in the disc tray, it automatically begins playing from the first track.

**2** Press **▲ OPEN/CLOSE** to open the tray and insert a disc.  
Label must face upward

**3** Press **▲ OPEN/CLOSE** to close the tray.  
Total number of tracks      Total playing time  
12      56:08  
1 2 3 4 5 6 7 8 9 10 11 12

Displayed if there are 21 or more tracks on the disc  
On SL-PG360A, this indicator appears when there are 17 or more tracks on the disc.

**4** Press **▶ (Play begins)**.  
Play stops automatically after all tracks have been played.  
Index number  
(If there is none, " / " is displayed.)  
Track currently playing      Elapsed time  
1      0:01  
1 2 3 4 5 6 7 8 9 10 11 12  
Illuminates.

■ To stop disc play

Press ■.

■ To pause disc play

Press ||.

To continue playback, press ▶.

**Notes**

- The displayed total playing time includes the time between tracks. For this reason, the time may be several seconds longer than that which appears on song cards and the like.
- When you use the timer with other unit, be sure to turn this unit on.

**For your reference:**

If you skip step 3 and press ▶, the tray automatically closes and play begins from the first track.

## To listen with headphones

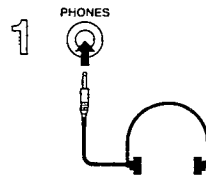

**Connect headphones (not included).**

- Lower the volume before connecting.
- Plug type: Large stereo type

**Adjust the volume with the PHONES LEVEL knob.**

To make louder:  
Turn toward the right.

To make lower:  
Turn toward the left.

**Note**

Avoid listening for prolonged periods of time to prevent hearing damage.

## Disassembly Instructions





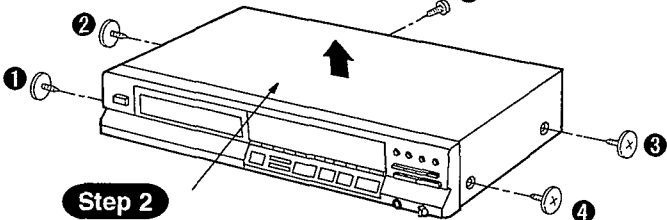
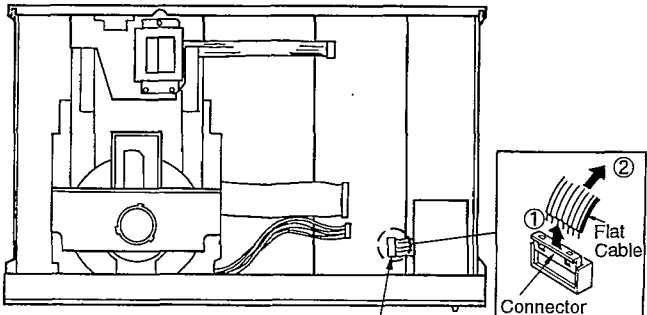
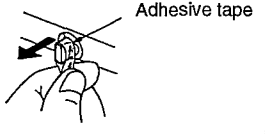
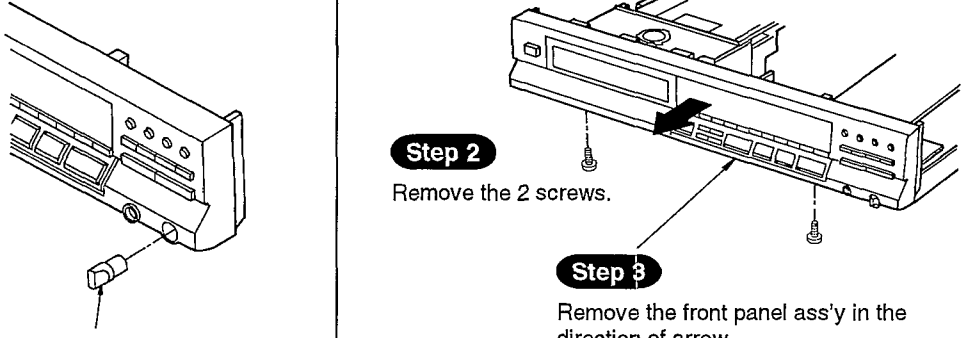
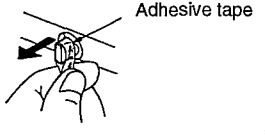
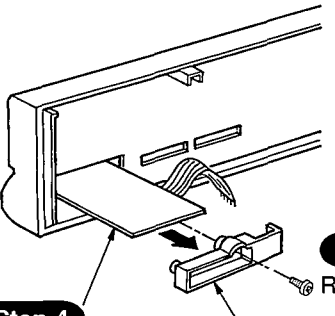
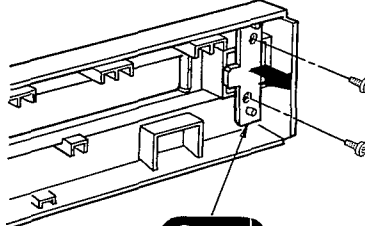

**Warning:** This product uses a laser diode. Refer to caution statements on page 2.

**ACHTUNG:** Die Lasereinheit nicht zerlegen.

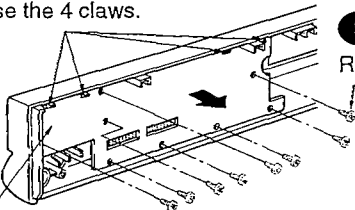
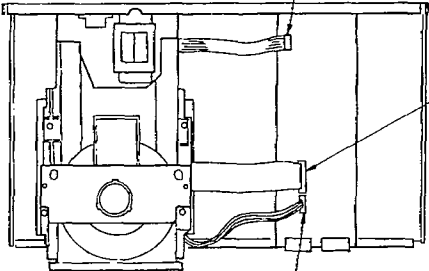
Die Lasereinheit darf nur gegen eine vom Hersteller spezifizierte Einheit ausgetauscht werden.

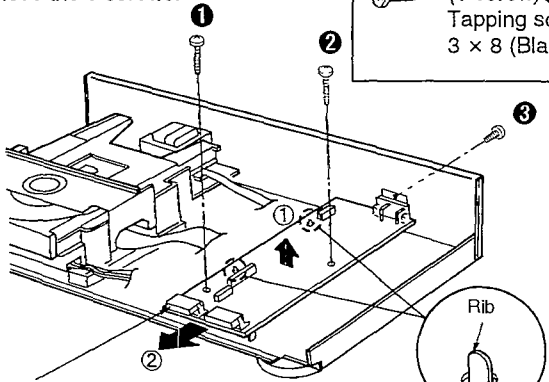
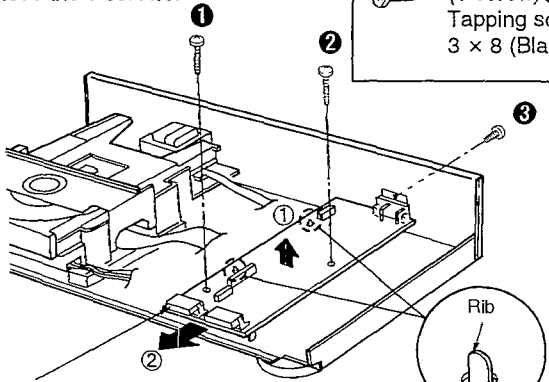
**"ATTENTION SERVICER"** Some chassis components may have sharp edges. Be careful when disassembling and servicing.

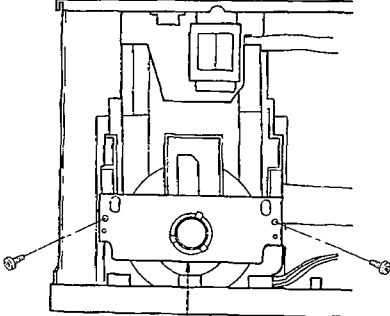
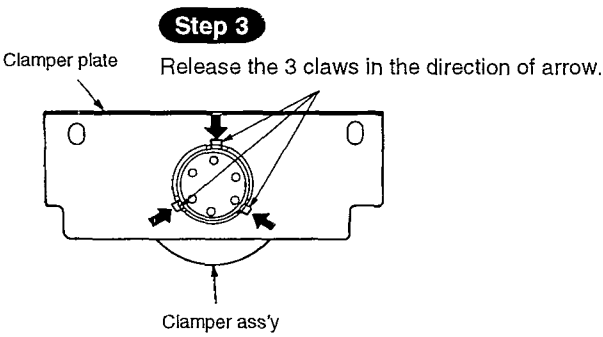
<p>Ref. No. 1</p>	<p><b>Removal of the cabinet</b></p>	<p>Ref. No. 2</p>	<p><b>Removal of the front panel ass'y</b></p>
<p>Procedure 1</p>	<div data-bbox="539 412 794 584" style="border: 1px solid black; padding: 5px;"> <p>(4 screws) ①~④ (Black)</p> <p>(1 screw) ⑤ Tapping screw 3 × 8 (Black)</p> </div> <p><b>Step 1</b> Remove the 5 screws.</p>  <p><b>Step 2</b> Remove the cabinet in the direction of arrow.</p>	<p>Procedure 1→2</p>	 <p><b>Step 1</b> Remove the flat cable from connector (CN891).</p>
<p>Ref. No. 3</p>	<p><b>Removal of the headphones P.C.B.</b></p>	<p>Ref. No. 4</p>	<p><b>Removal of the power switch P.C.B.</b></p>
<p>Procedure 1→2→3</p>	<p>● Pull out the headphones level knob with using adhesive tape when removing the headphones level knob.</p>  <p>Adhesive tape</p>  <p><b>Step 1</b> Pull out the headphones level knob.</p>	<div data-bbox="1252 943 1508 1048" style="border: 1px solid black; padding: 5px;"> <p>(2 screws) Tapping screw 3 × 8 (Black)</p> </div> <p><b>Step 2</b> Remove the 2 screws.</p> <p><b>Step 3</b> Remove the front panel ass'y in the direction of arrow.</p>	<div data-bbox="1252 1541 1508 1646" style="border: 1px solid black; padding: 5px;"> <p>(2 screws) Tapping screw 2.6 × 8</p> </div> <p><b>Step 1</b> Remove the 2 screws.</p> <p><b>Step 2</b> Remove the power switch P.C.B. in the direction of arrow.</p>
<p>● Pull out the headphones level knob with using adhesive tape when removing the headphones level knob.</p>  <p>Adhesive tape</p> <p><b>Step 1</b> Pull out the headphones level knob.</p> <div data-bbox="550 1592 805 1697" style="border: 1px solid black; padding: 5px;"> <p>(1 screw) Tapping screw 2.6 × 8</p> </div> <p><b>Step 2</b> Remove the 1 screw.</p> <p><b>Step 3</b> Remove the headphones holder.</p> <p><b>Step 4</b> Remove the headphones P.C.B. in the direction of arrow.</p>	 <p><b>Step 2</b> Remove the 1 screw.</p> <p><b>Step 3</b> Remove the headphones holder.</p> <p><b>Step 4</b> Remove the headphones P.C.B. in the direction of arrow.</p>	<p>Ref. No. 4</p> <p>Procedure 1→2→4</p> <div data-bbox="1252 1541 1508 1646" style="border: 1px solid black; padding: 5px;"> <p>(2 screws) Tapping screw 2.6 × 8</p> </div> <p><b>Step 1</b> Remove the 2 screws.</p> <p><b>Step 2</b> Remove the power switch P.C.B. in the direction of arrow.</p>	 <p><b>Step 1</b> Remove the 2 screws.</p> <p><b>Step 2</b> Remove the power switch P.C.B. in the direction of arrow.</p>

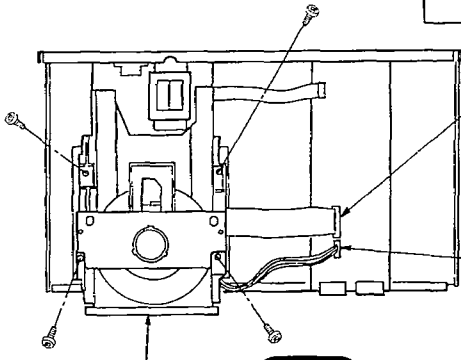
<p>Ref. No. 5</p>	<p><b>Removal of the operation P.C.B.</b></p>	<p>Ref. No. 6</p>	<p><b>Removal of the main P.C.B.</b></p>
<p>Procedure 1→2→3→5</p>	<div data-bbox="499 203 756 309" style="border: 1px solid black; padding: 5px;">  (8 screws) Tapping screw 2.6 × 8         </div> <p><b>Step 2</b> Release the 4 claws.</p>  <p><b>Step 1</b> Remove the 8 screws.</p> <p><b>Step 3</b> Remove the operation P.C.B. in the direction of arrow.</p>	<p>Procedure 1→2→6</p> <p><b>Step 1</b> Remove the flat cable from connector (CN11).</p>  <p><b>Step 2</b> Pull out the flexible cable from connector (CN401).</p> <p><b>Step 3</b> Remove the connector (CN402).</p>	<div data-bbox="1209 663 1474 853" style="border: 1px solid black; padding: 5px;">  (2 screws) ①, ② Tapping screw 3 × 20 (Black)  (1 screw) ③ Tapping screw 3 × 8 (Black)         </div> <p><b>Step 4</b> Remove the 3 screws.</p>  <p><b>Step 5</b> Lift up the main P.C.B. in the direction of arrow ①, and release the 2 ribs on the chassis ass'y. Then, remove the main P.C.B. in the direction of arrow ②.</p> 
<p>Ref. No. 7</p>	<p><b>Removal of the clamber plate and clamber ass'y</b></p>		
<p>Procedure 1→7</p>	<div data-bbox="512 808 767 913" style="border: 1px solid black; padding: 5px;">  (2 screws) Tapping screw 3 × 8 (Black)         </div>  <p><b>Step 1</b> Remove the 2 screws.</p> <p><b>Step 2</b> Remove the clamber plate.</p>	<p>Ref. No. 8</p> <p><b>Removal of the loading unit</b></p>	
	<p><b>Step 3</b> Release the 3 claws in the direction of arrow.</p>  <p>Clamber plate</p> <p>Clamber ass'y</p>	<p>Procedure 1→2→8</p>	<div data-bbox="1214 1435 1474 1547" style="border: 1px solid black; padding: 5px;">  (4 screws) Tapping screw 3 × 8 (Black)         </div>  <p><b>Step 1</b> Pull out the flexible cable from connector (CN401).</p> <p><b>Step 2</b> Remove the connector (CN402).</p> <p><b>Step 3</b> Remove the 4 screws.</p>

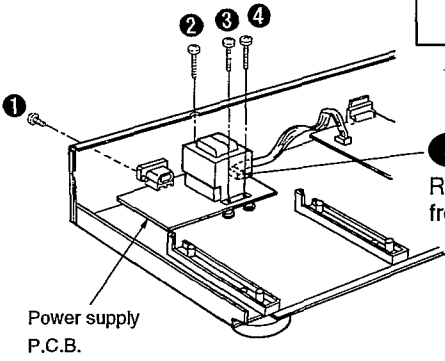
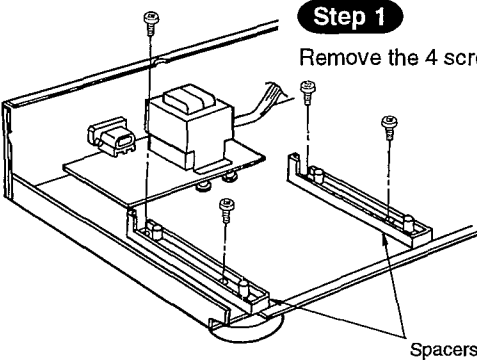
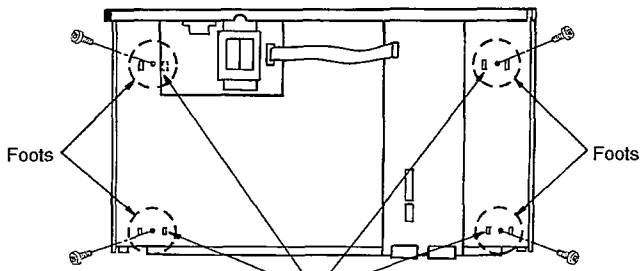
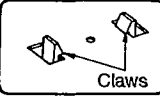
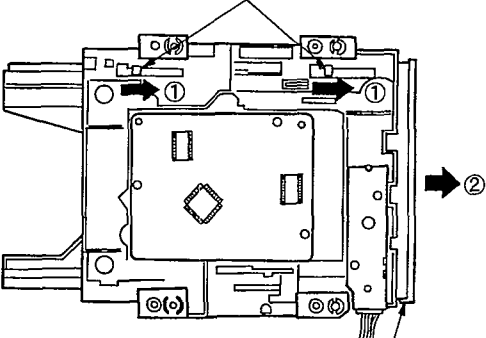
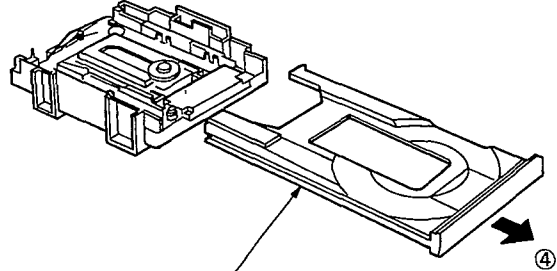
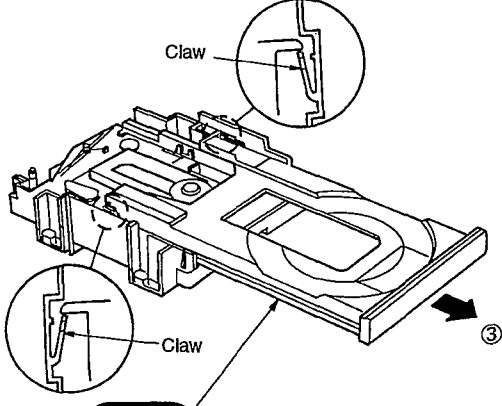

<p>Ref. No. 9</p>	<p><b>Removal of the power supply P.C.B.</b></p>	<p>Ref. No. 10</p>	<p><b>Removal of the spacer</b></p>
<p>Procedure 1→2→8→9</p> <p><b>Step 1</b> Remove the 4 screws.</p>  <p>Power supply P.C.B.</p>	<div style="border: 1px solid black; padding: 5px; margin-bottom: 10px;"> <p>(1 screw) ① Tapping screw 3 × 8 (Black)</p> <p>(3 screws) ②~④ Tapping screw 3 × 20 (Black)</p> </div> <p><b>Step 2</b> Remove the flat cable from connector (CN21).</p>	<p>Procedure 1→2→8→10</p>	<div style="border: 1px solid black; padding: 5px; margin-bottom: 10px;"> <p>(4 screws) Tapping screw 3 × 8 (Black)</p> </div> <p><b>Step 1</b> Remove the 4 screws.</p>  <p>Spacers</p>
<p>Ref. No. 11</p>	<p><b>Removal of the foots</b></p>	<p>Ref. No. 12</p>	<p><b>Removal of the disc tray</b></p>
<p>Procedure 1→2→8→10 →11</p> <p><b>Step 1</b> Remove the 4 screws.</p>  <p>Foots</p>	<div style="border: 1px solid black; padding: 5px; margin-bottom: 10px;"> <p>(4 screws) Tapping screw 3 × 8 (Black)</p> </div> <p><b>Step 2</b> Release the 8 claws.</p>  <p>Claws</p>	<p>Procedure 1→2→7→8→12</p>	<p><b>Step 1</b> Push the 2 levels fully in the direction of the arrows ①. (Traverse unit in moved down.)</p>  <p><b>Step 2</b> Move the disc tray slightly in the direction of arrow ②.</p>
<p><b>Step 4</b> Remove the disc tray in the direction of arrow ④.</p> 	<p><b>Step 3</b> Release the 2 claws, and then move the disc tray in the direction of arrow ③.</p>  <p>Claw</p> <p>Claw</p>		

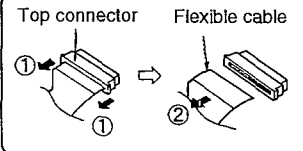
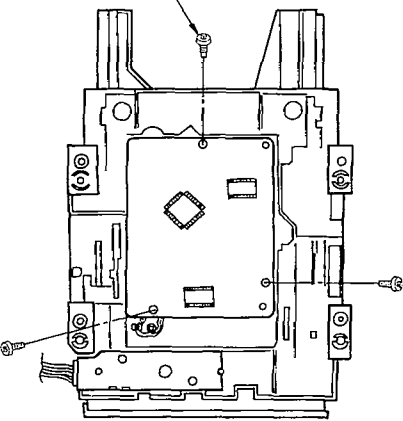
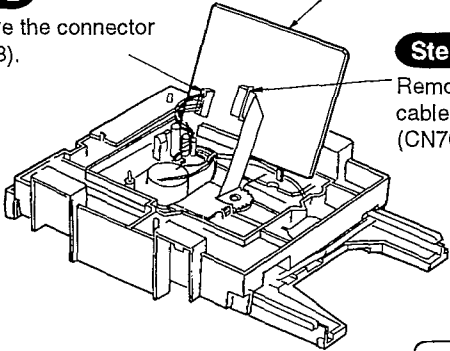
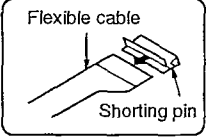
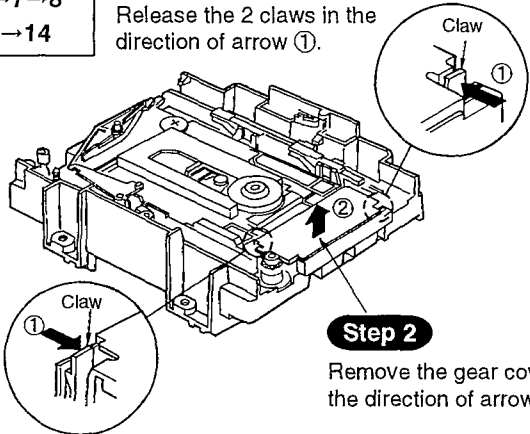
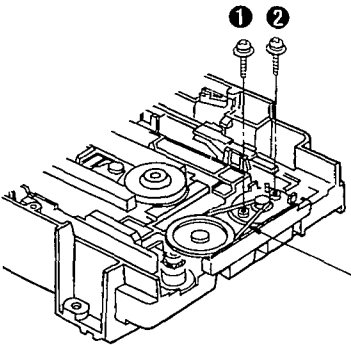
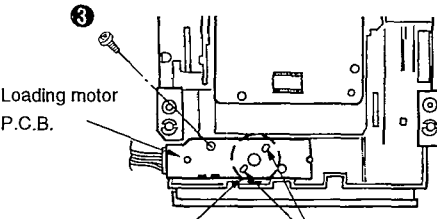
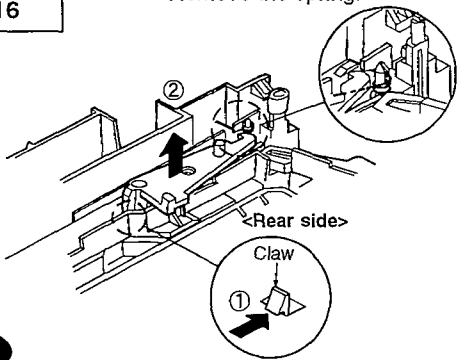
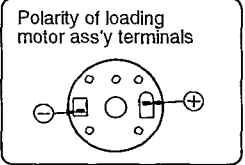
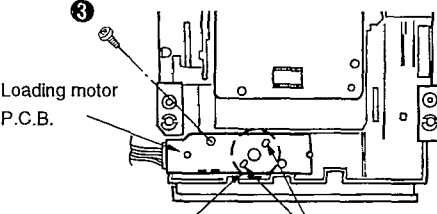
<p>Ref. No. 13</p>	<p><b>Removal of the servo P.C.B.</b></p>	<p><b>■Removal of the flexible cable</b>                  ●Push the top of the connector in the direction of arrow ①, and then pull out the flexible cable in the direction of arrow ②.</p> 
<p>Procedure 1→2→8→13</p>	<p>(3 screws) Tapping screw 2.6 × 8</p>	<p><b>Step 1</b> Remove the 3 screws.</p> 
	<p><b>Step 2</b> Remove the connector (CN703).</p> 	<p><b>Step 3</b> Remove the flexible cable from connector (CN701).</p> <p><b>Note:</b> Insert a shorting pin into the traverse unit flexible cable. (Refer to Handling Precautions for Traverse Deck on page 2.)</p> 
<p>Ref. No. 14</p>	<p><b>Removal of the gear cover</b></p>	<p>Ref. No. 15</p> <p><b>Removal of the loading motor P.C.B. and loading motor ass'y</b></p>
<p>Procedure 1→2→7→8 →12→14</p>	<p><b>Step 1</b> Release the 2 claws in the direction of arrow ①.</p> 	<p>Procedure 1→2→7→8→ 12→14→15</p> <p><b>Step 1</b> Remove the 2 screws.</p> 
	<p><b>Step 2</b> Remove the gear cover in the direction of arrow ②.</p>	<p>(2 screws) ①, ② Tapping screw 2 × 6 (Black)</p> <p>(1 screw) ③ Tapping screw 2.6 × 8</p> <p><b>Step 2</b> Remove the belt.</p>
<p>Ref. No. 16</p>	<p><b>Removal of the lock lever</b></p>	<p><b>Step 3</b> Remove the 1 screw.</p> 
<p>Procedure 1→2→7→8 →12→16</p>	<p><b>Step 1</b> Remove the spring.</p> 	<p>Polarity of loading motor ass'y terminals</p> 
	<p><b>Step 2</b> Push the claw in the direction of arrow ① and then lift up the lock lever in the direction of arrow ②.</p>	<p><b>Step 4</b> Unsolder the loading motor ass'y terminals (2 points).</p> 

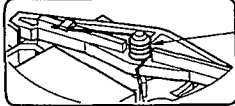
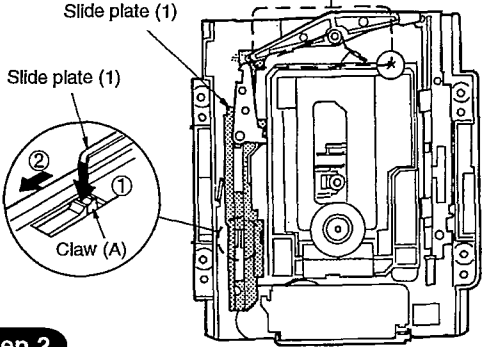
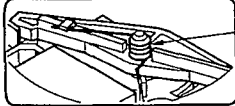
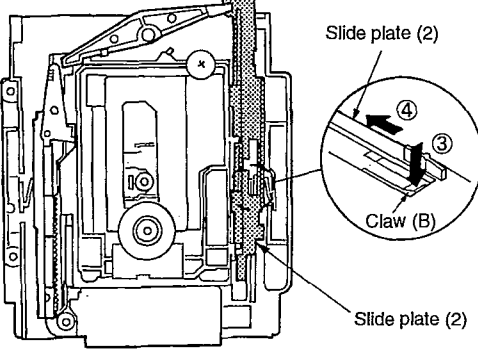
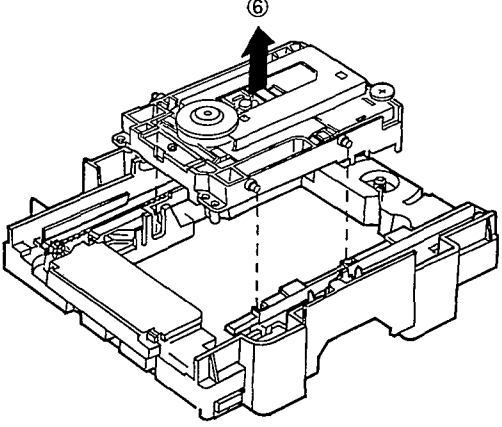
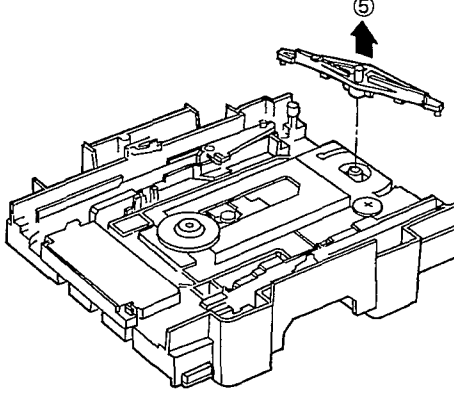
<p><b>Ref. No.</b> 17</p>	<p><b>Removal of the converter lever and traverse deck ass'y</b></p>	<p><b>Note:</b> Be careful not to damage the claw (A) or (B) because the claw (A) or (B) is breakable.</p>
<p><b>Procedure</b> 1→2→7→8→ 12→13→17</p>	<p><b>Step 1</b> Remove the spring.</p> 	
		
<p><b>Step 2</b> Push the claw (A) in the direction of arrow ①, and then move the slide plate (1) in the direction of arrow ②.</p>	<p><b>Step 3</b> Push the claw (B) in the direction of arrow ③, and then move the slide plate (2) in the direction of arrow ④.</p>	<p><b>Step 4</b> Remove the converter lever in the direction of arrow ⑤.</p>
<p><b>Step 5</b> Remove the traverse deck ass'y in the direction of arrow ⑥.</p> 		

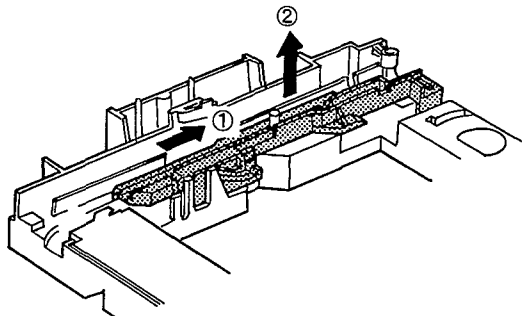
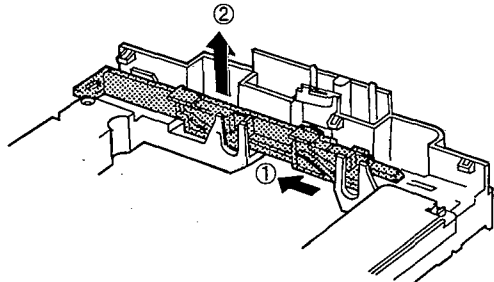
<p><b>Ref. No.</b> 18</p>	<p><b>Removal of the slide plate (1)</b></p>	<p><b>Ref. No.</b> 19</p>	<p><b>Removal of the slide plate (2)</b></p>
<p><b>Procedure</b> 1→2→7→8→ 12→13→16→ 17→18</p>	<p><b>Step 1</b> Move the slide plate (1) in the direction of arrow ①, and lift up the slide plate (1) in the direction of arrow ②.</p>	<p><b>Procedure</b> 1→2→7→8→12 →13→17→19</p>	<p><b>Step 1</b> Move the slide plate (2) in the direction of arrow ①, and lift up the slide plate (2) in the direction of arrow ②.</p>
			

**Ref. No. 20**      **Removal of the traverse deck**

**Procedure**  
 1→2→7→8→  
 12→13→17→  
 20

**Step 1**  
 Remove the 2 screws.

**Step 2**  
 Remove the traverse stopper

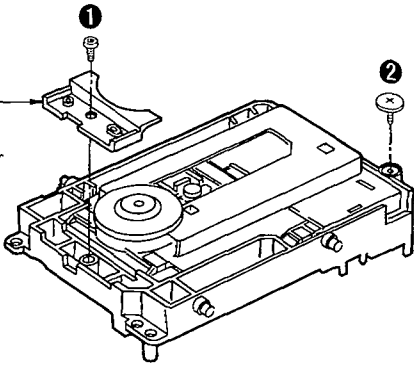

**Step 4**

Push the damping rubber in the direction of arrow ①, and then remove it from traverse chassis.

**Step 3**

Remove the lead wire from clamber.

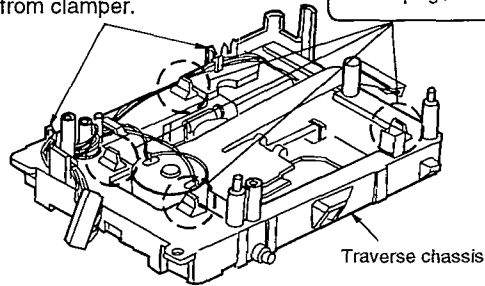
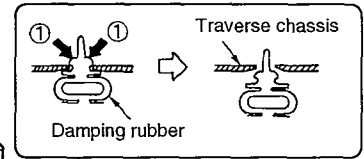

**Ref. No. 21**      **Removal of the drive rack**

**Procedure**  
 1→2→7→8  
 →12→21

(1 screw)  
 Tapping screw  
 2 × 5 (Black)

**Step 1** Remove the 1 screw.

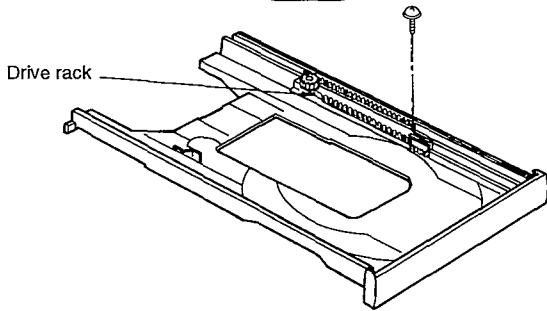

(1 screw) ①  
 Tapping screw  
 2.6 × 8 (Black)  
 (1 screw) ②  
 Tapping screw  
 3 × 8

**Step 5**

Remove the traverse deck in the direction of arrow ②.

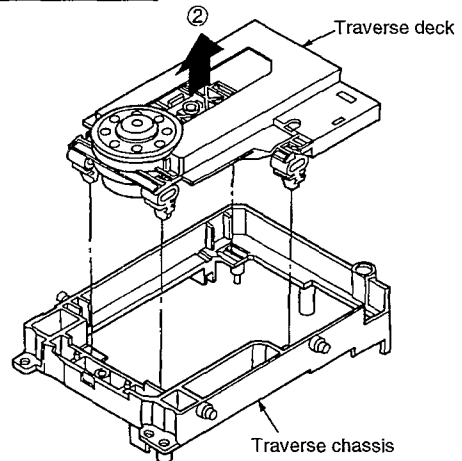

**Ref. No. 22**      **Removal of the disc tray ornament**

**Procedure**  
 1→2→8→21

**Step 1**

Release the 2 claws, and then remove the disc tray ornament in the direction of arrow.

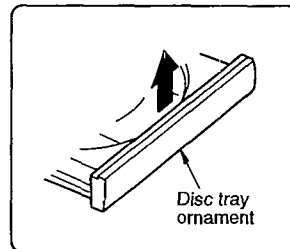
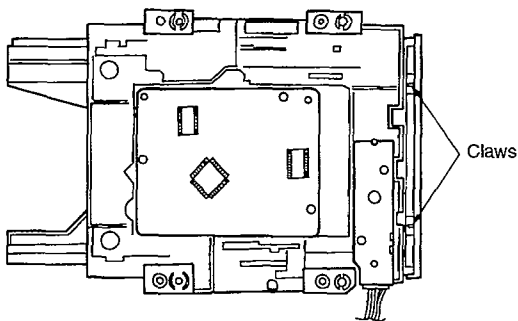

## ■ Installing Disc Tray

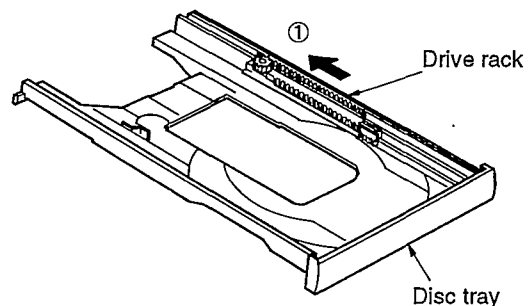

### Step 1

Slide the drive rack fully in the direction of arrow ①.

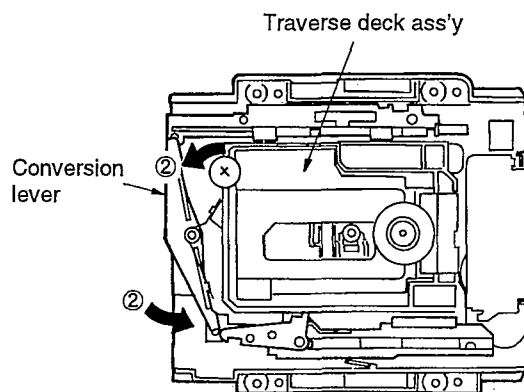

### Step 2

Slide the conversion lever in the direction of arrow ②, and then leave the traverse deck ass'y falling.

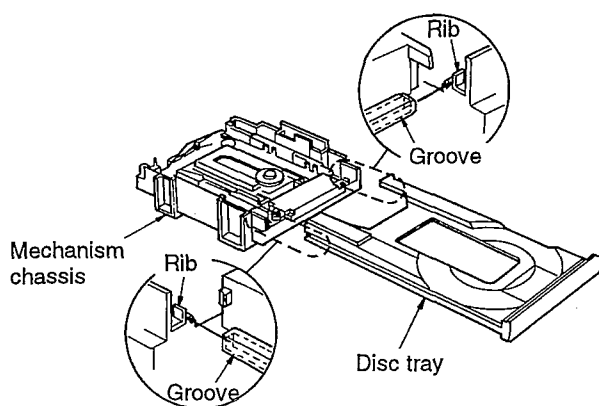

### Step 3

Align the disc tray groove with the mechanism chassis rib.

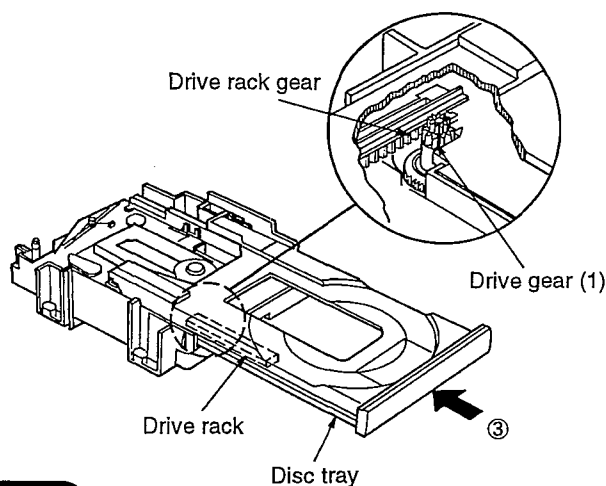

### Step 4

Slide the disc tray in the direction of arrow ③. Then, put the drive rack manually so that the drive gear (1) engages with the drive rack gear.

### Step 5

After the drive gear (1) engaged with the drive rack gear, slide the disc tray in the direction of arrow ③.

## ■ Dispose of Wire

1. Dispose of wire in due order **a** to **f**.
2. Slacken off the each wire between solder part and each claw.

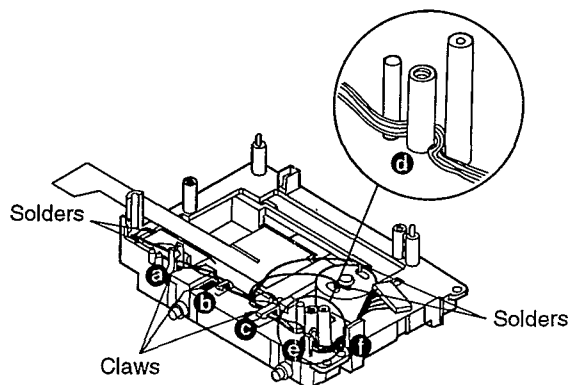

## ■How to Check the Main P.C.B.

1. Remove the cabinet referring to Procedure 1 "Removal of the cabinet" on page 7.
2. Remove the front panel ass'y referring to Procedure 2 "Removal of the front panel ass'y" on page 7.
3. Remove the headphones P.C.B. referring to Procedure 3 "Removal of the headphones P.C.B." on page 7.
4. Remove the operation P.C.B. referring to Procedure 5 "Removal of the operation P.C.B." on page 8.

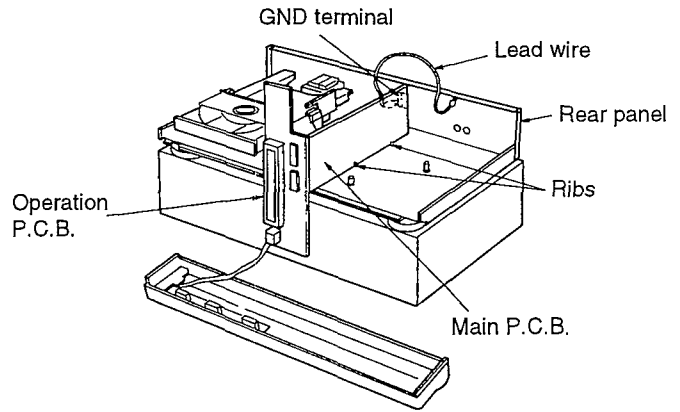
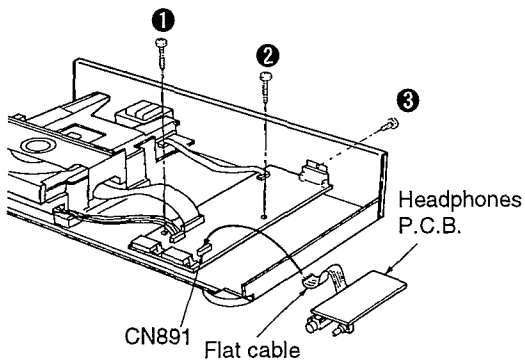

5. Remove the 3 screws (1 ~ 3).
6. Remove the main P.C.B. and then stand the main P.C.B. at the side of unit.
7. Connect the flat cable with headphones P.C.B. to the connector (CN891) on main P.C.B.

8. Reinstall the operation P.C.B. to the main P.C.B.
9. Connect the GND terminal to the rear panel by the lead wire.
10. When checking the soldered surface of the main P.C.B., do as shown above.

## ■How to Check the Servo P.C.B.

1. Remove the cabinet referring to Procedure 1 "Removal of the cabinet" on page 7.

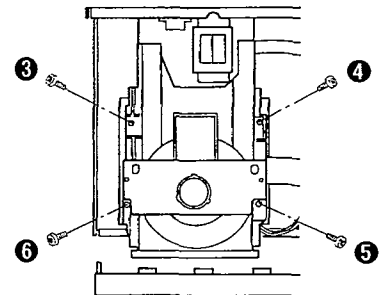
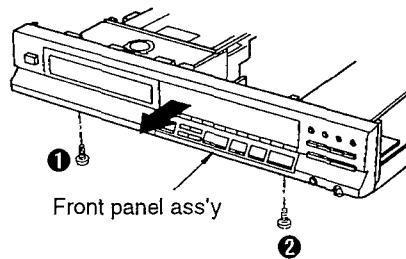
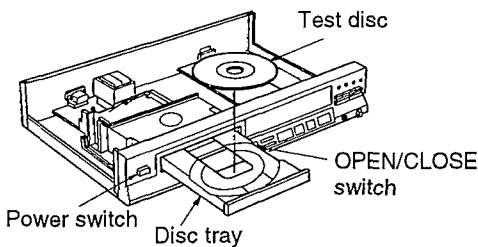

2. Turn on the power and press the OPEN/CLOSE switch to open the disc tray.
3. Load the test disc and press the OPEN/CLOSE switch again to close the disc tray.

4. Turn the power switch "OFF".
5. Remove the 2 screws (1, 2).
6. Draw the front panel ass'y in the direction of arrow.

7. Remove the 4 screws (3 ~ 6).

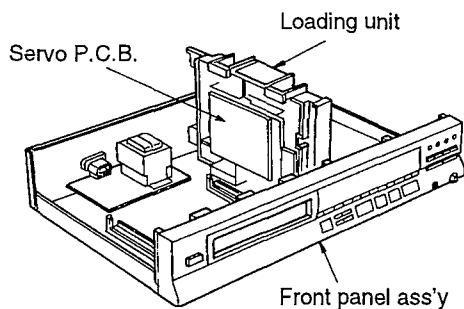

8. Place the loading unit sideways as shown in the figure left.
9. Attach the front panel ass'y to the unit.
10. After placing the unit as shown left, perform check and adjustment of the foil on the servo P.C.B.

Block Diagram

Note: → AUDIO SIGNAL

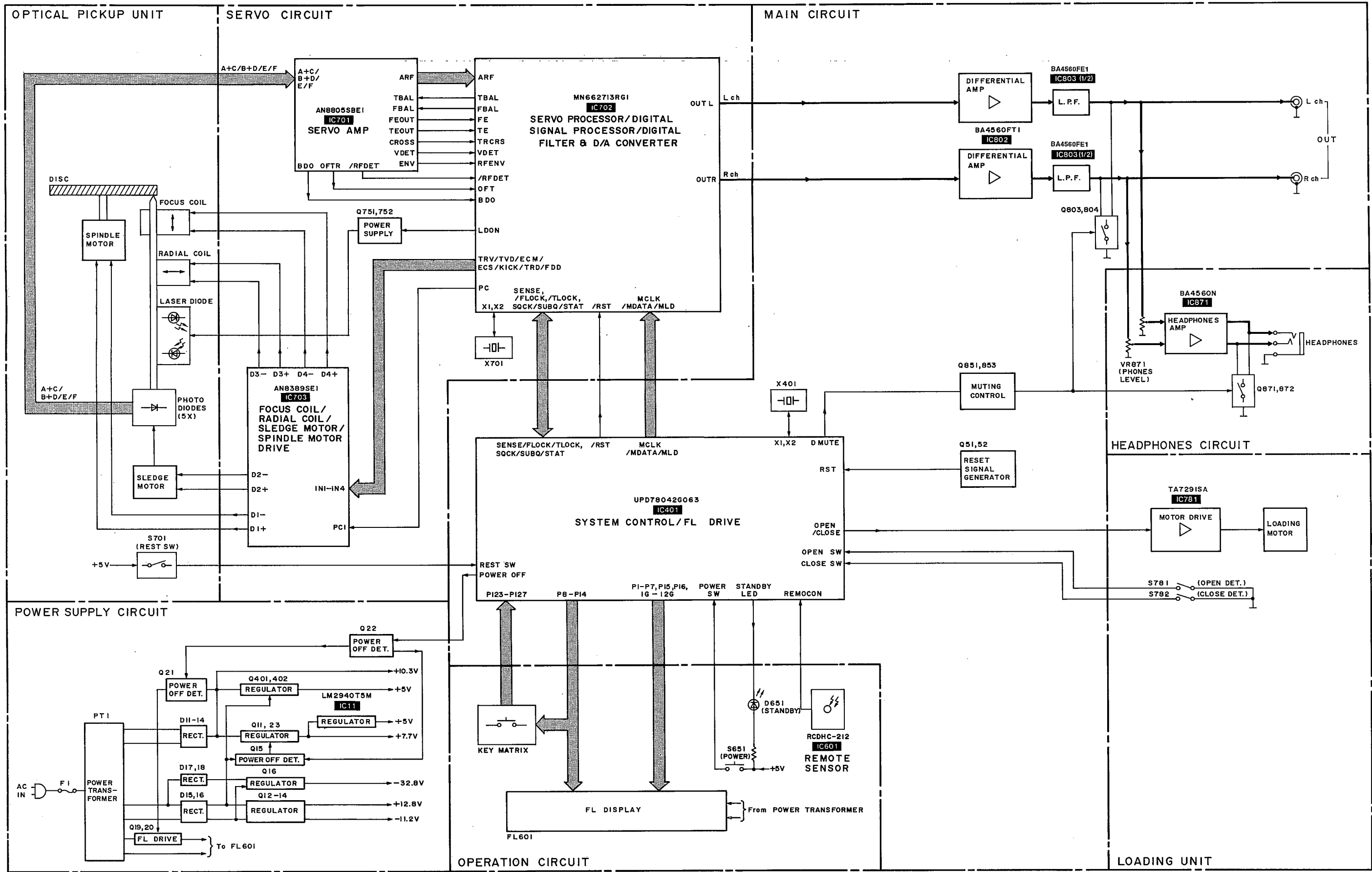

Schematic Diagram Optical Pickup/Servo Circuit (Parts list on pages 34~36.)

1 2 3 4 5 6 7 8 9

A

B

C

D

E

F

A SERVO CIRCUIT

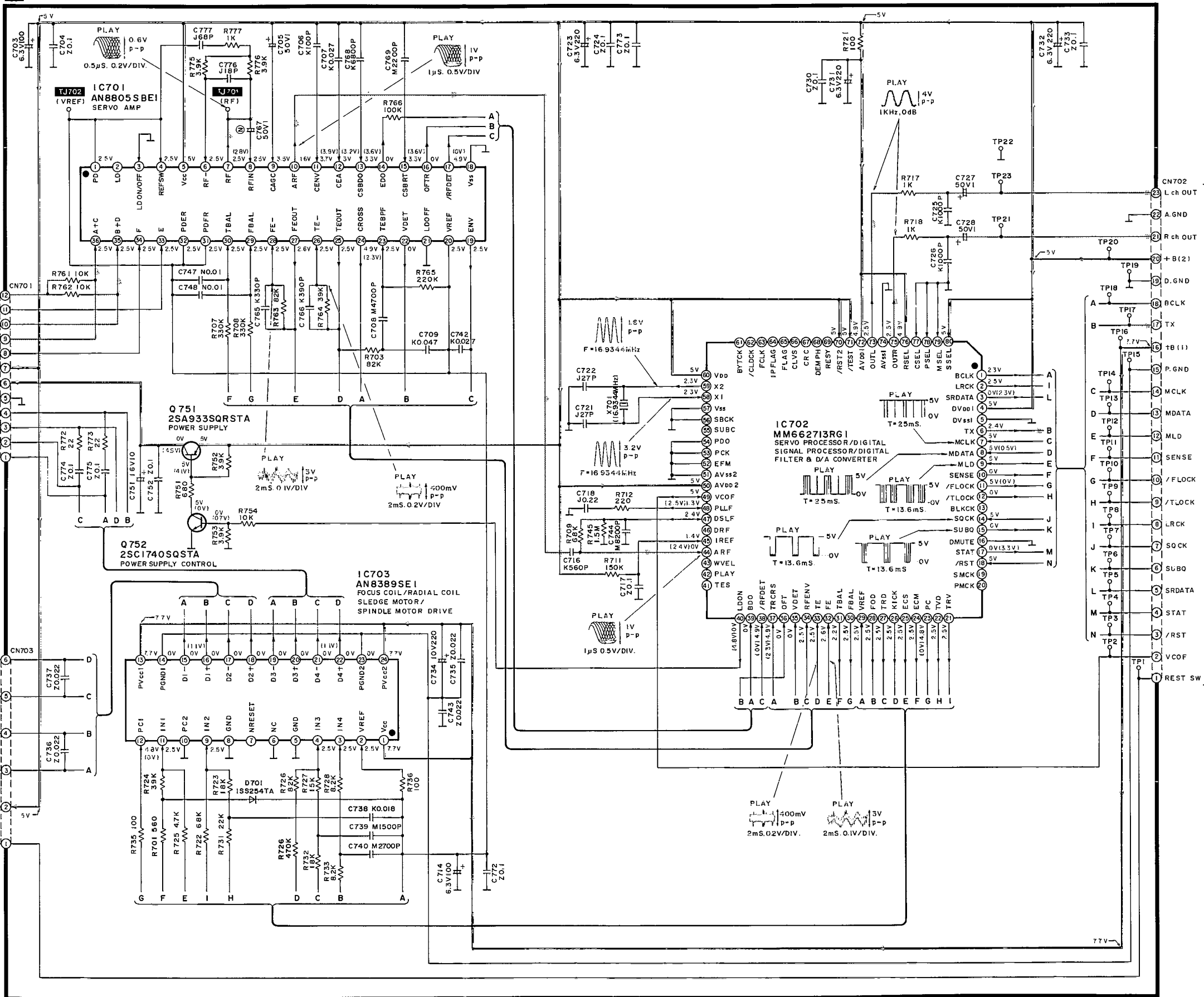
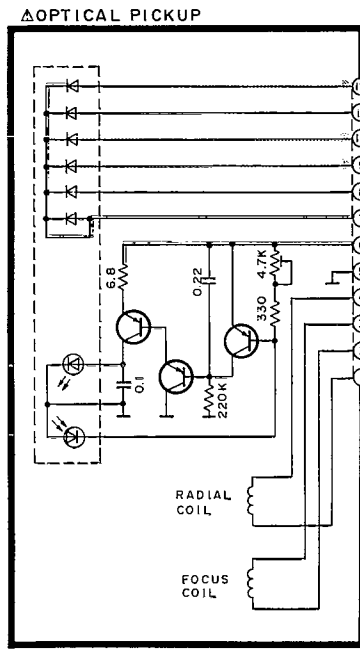

To E MAIN CIRCUIT (CN401) (Page 20)



●Main/Operation/Loading Motor/Power Supply/Headphones Jack Circuit (Parts list on page 34~36.)

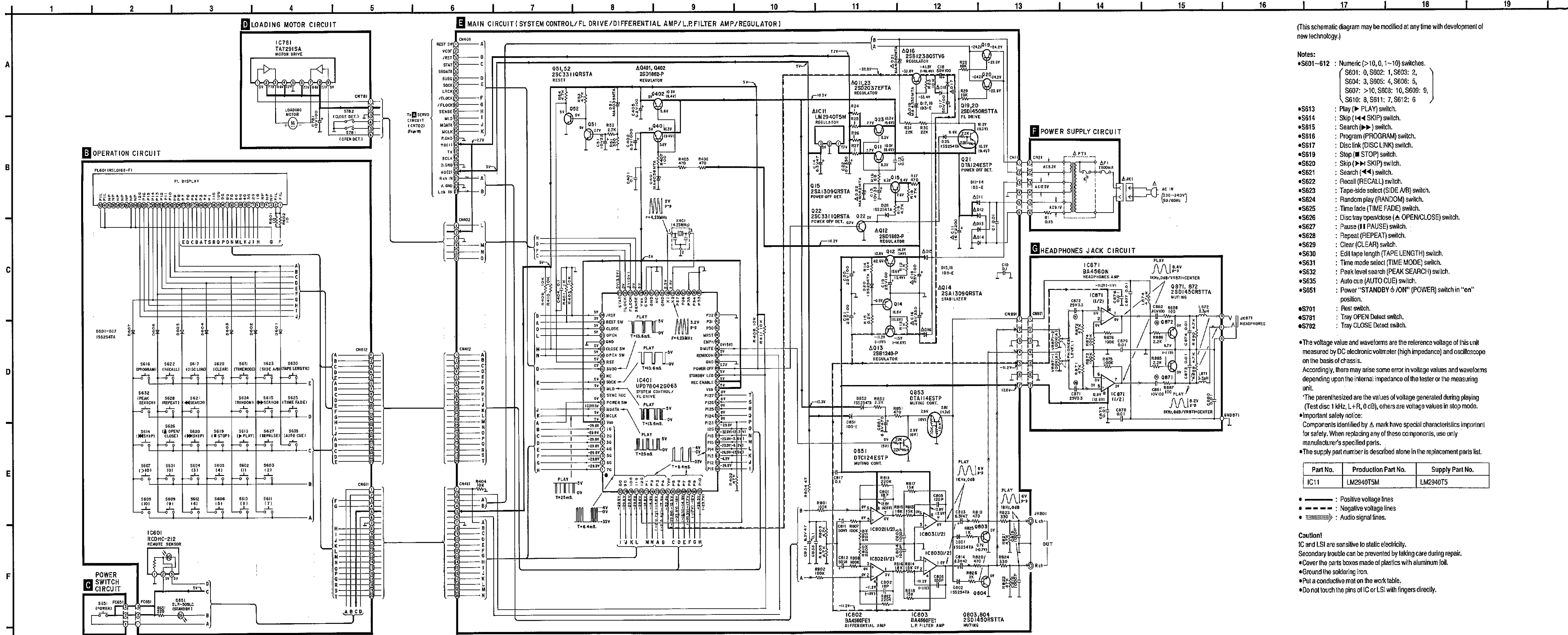

(This schematic diagram may be modified at any time with development of new technology.)

- Notes:
- S601~612 : Numeric (>10, 0, 1~10) switches.
    - S601: 0, S602: 1, S603: 2,
    - S604: 3, S605: 4, S606: 5,
    - S607: >10, S608: 10, S609: 9,
    - S610: 8, S611: 7, S612: 6
  - S613 : Play (▶) switch.
  - S614 : Skip (◀◀ SKIP) switch.
  - S615 : Search (▶▶) switch.
  - S616 : Program (PROGRAM) switch.
  - S617 : Disc link (DISC LINK) switch.
  - S619 : Stop (■ STOP) switch.
  - S620 : Skip (▶▶) SKIP switch.
  - S621 : Search (◀◀) switch.
  - S622 : Recall (RECALL) switch.
  - S623 : Tape-side select (SIDE A/B) switch.
  - S624 : Random play (RANDOM) switch.
  - S625 : Time fade (TIME FADE) switch.
  - S626 : Disc tray open/close (▲ OPEN/CLOSE) switch.
  - S627 : Pause (|| PAUSE) switch.
  - S628 : Repeat (REPEAT) switch.
  - S629 : Clear (CLEAR) switch.
  - S630 : Edit tape length (TAPE LENGTH) switch.
  - S631 : Time mode select (TIME MODE) switch.
  - S632 : Peak level search (PEAK SEARCH) switch.
  - S635 : Auto cue (AUTO CUE) switch.
  - S651 : Power "STANDBY & /ON" (POWER) switch in "on" position.
  - S701 : Rest switch.
  - S781 : Tray OPEN Detect switch.
  - S782 : Tray CLOSE Detect switch.

●The voltage value and waveforms are the reference voltage of this unit measured by DC electronic voltmeter (high impedance) and oscilloscope on the basis of chassis. Accordingly, there may arise some error in voltage values and waveforms depending upon the internal impedance of the tester or the measuring unit.

\*The parenthesis are the values of voltage generated during playing (Test disc 1 kHz, L+R, 0 dB), others are voltage values in stop mode.

●Important safety notice:  
Components identified by Δ mark have special characteristics important for safety. When replacing any of these components, use only manufacturer's specified parts.

●The supply part number is described alone in the replacement parts list.

Part No.	Production Part No.	Supply Part No.
IC11	LM2940T5M	LM2940T5

- ——— : Positive voltage lines
  - - - - - : Negative voltage lines
  - ~~~~~ : Audio signal lines.
- Caution!**  
IC and LSI are sensitive to static electricity. Secondary trouble can be prevented by taking care during repair.
- Cover the parts boxes made of plastics with aluminum foil.
  - Ground the soldering iron.
  - Put a conductive mat on the work table.
  - Do not touch the pins of IC or LSI with fingers directly.

Printed Circuit Board Diagram

Wiring Connection Diagram

This circuit board diagram may be modified at any time with the development of new technology.

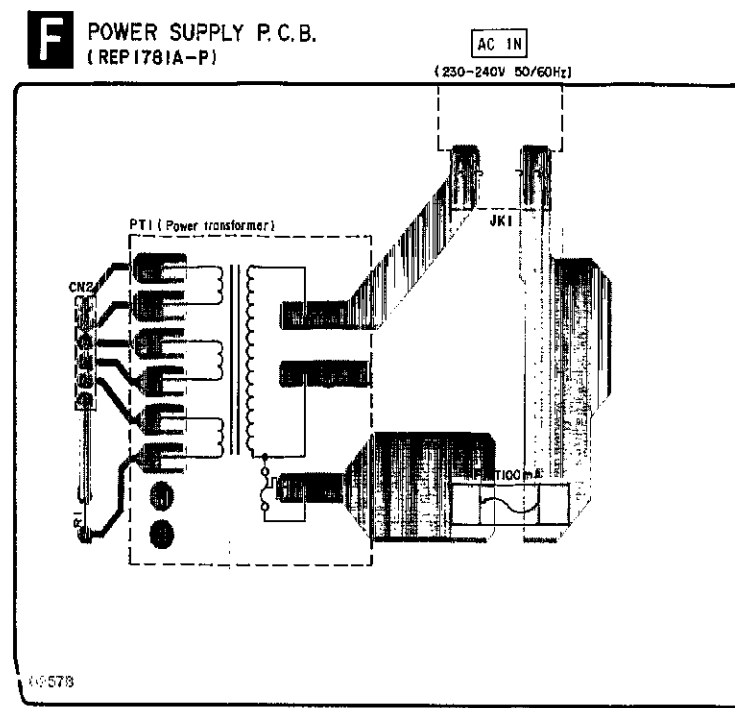
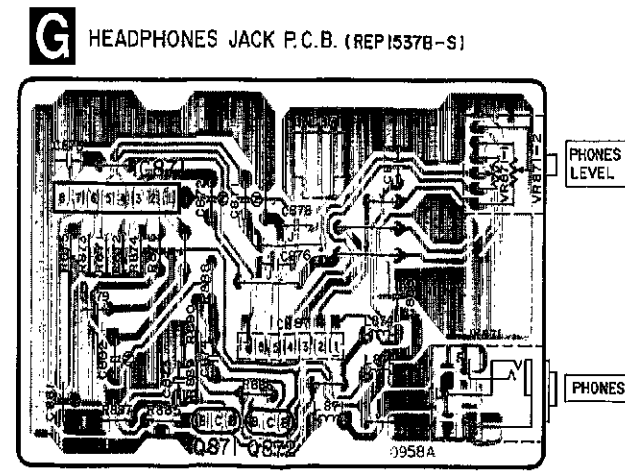
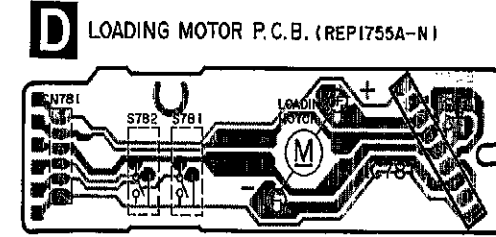
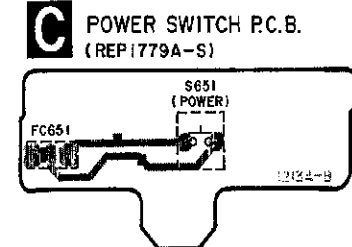
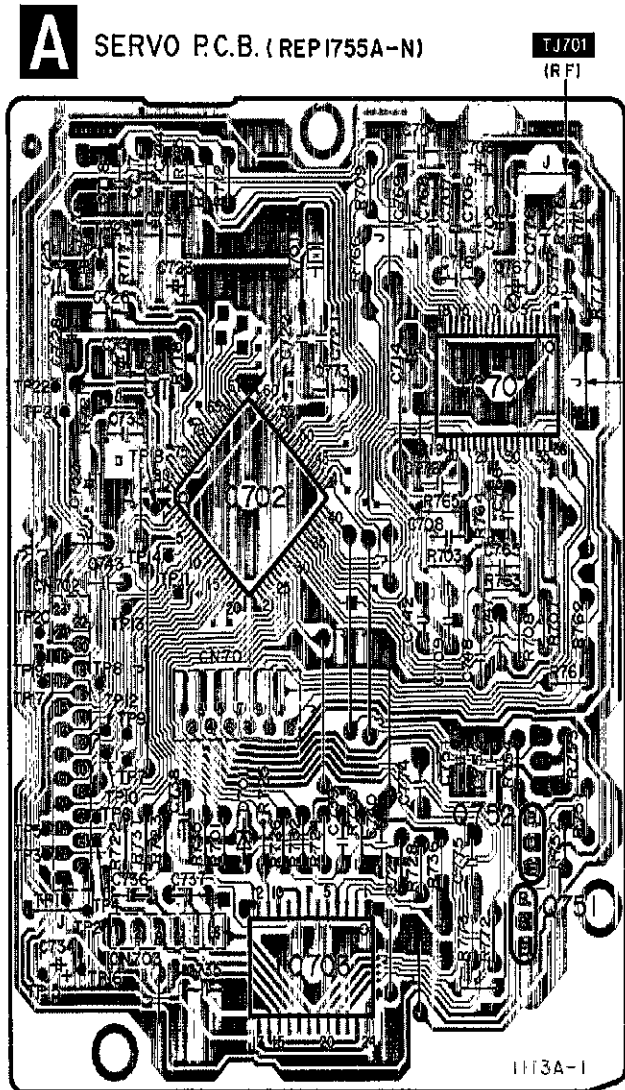
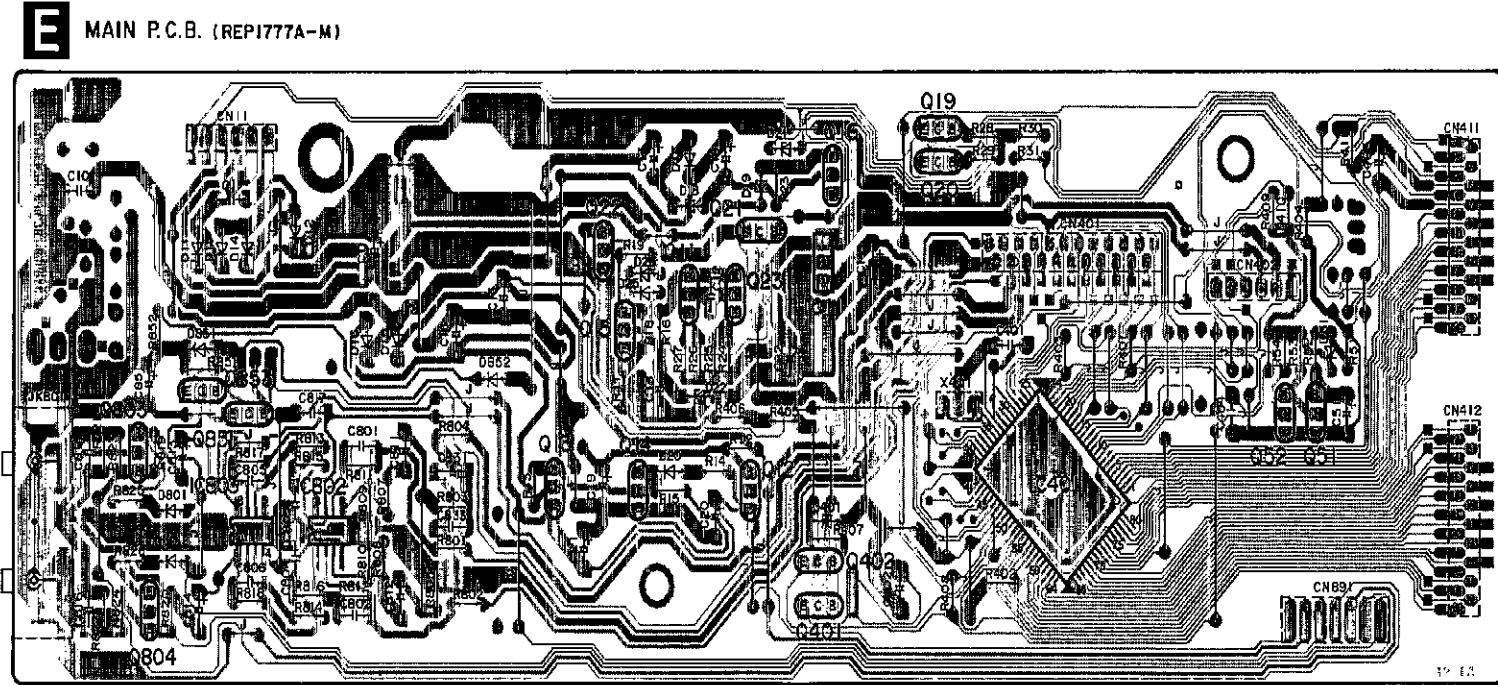
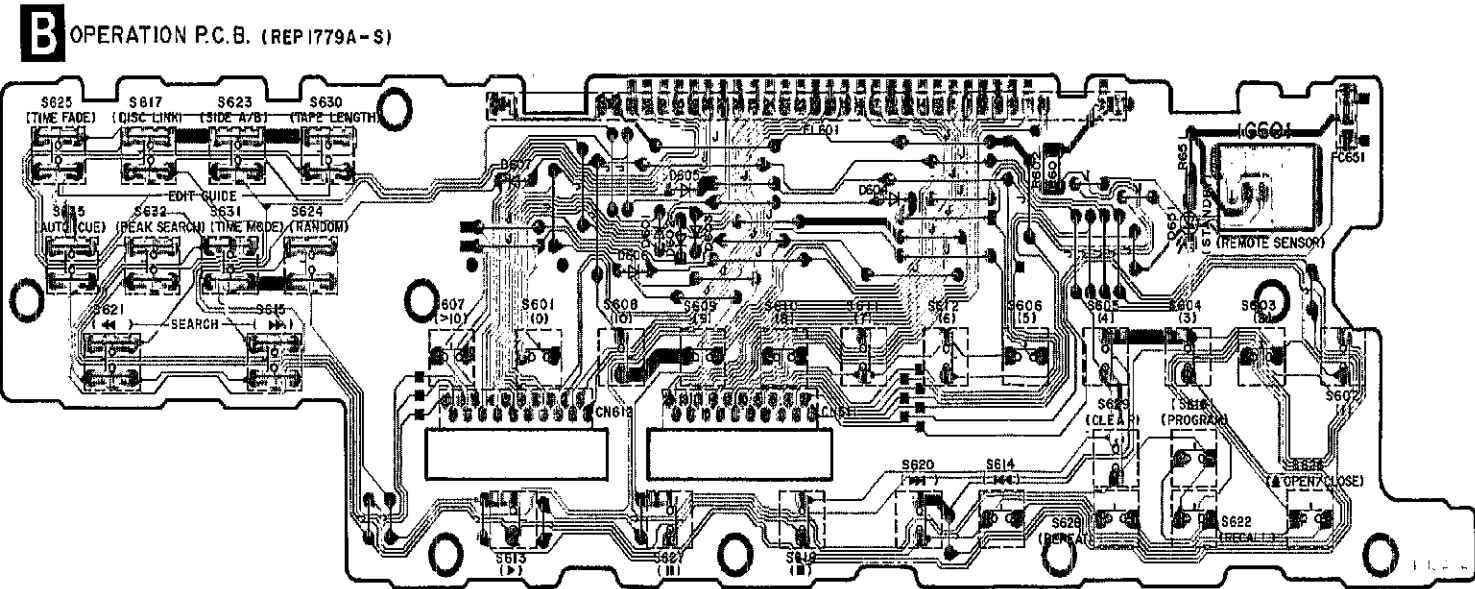

Terminal guide of IC's, transistors and diodes

BA480FE1 	AN8389SE1 	AN8905SE1 	MN662713RG1 	UPD79042G053 	BA4560N 
TA7291SA 	LM2940T5 	RCDHC-212 	2SA938SQRSTA 2SC1740SGSTA DTA114ESTP DTA124ESTP DTC124ESTP 	2SD2037EFTA 	
	2SA1309QRSTA 2SC3311QRSTA 2SD1450RSTTA 	2SB1238QSTV6 2SB1240-P 2SD1862-P 	1S8254TA 	1D3-E 	
MA4330MTA 	MA4039MTA MA4056MTA MA4082MTA 	SLR-305LC 			

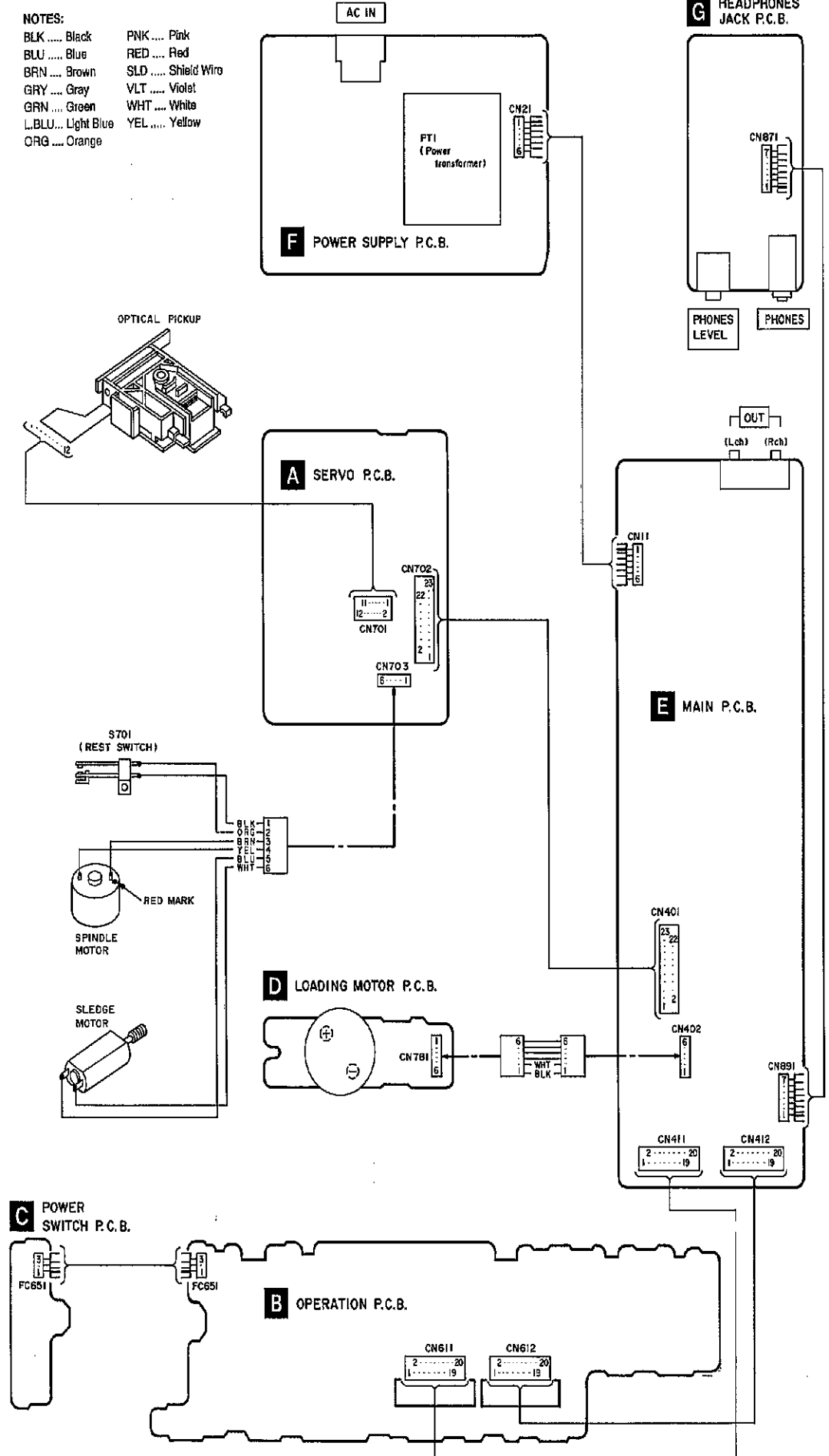

NOTES:  
 BLK .... Black  
 BLU .... Blue  
 BRN ... Brown  
 GRN ... Gray  
 GRN ... Green  
 L.BLU... Light Blue  
 ORG ... Orange  
 PINK ... Pink  
 RED ... Red  
 SLD ... Shield Wire  
 VLT ... Violet  
 WHT ... White  
 YEL ... Yellow

### Display Function of Automatically-Adjusted Results

(Self-Check Function)

The unit contains a function which displays the result of the automatically adjustment of the servo circuits (tracking, focus servo, etc.) as an error code on the FL display. The error code display serves as a repair guide showing the automatically adjustment circuit is at fault. The procedures for displaying the error codes are given below.

#### Procedures to display the error code

(1) Procedure to display the error code before disassembly (finished unit)

- When the [POWER] key is pressed while holding down the [STOP] [PAUSE] and [PLAY] keys simultaneously, the FL display illuminates, release the power turns on.
- When the FL display illuminates, release the [STOP] [PAUSE] and [PLAY] keys.
- Press the [OPEN/CLOSE] key to open the disc tray and load the test disc (SZZP1054C).
- Press the [PLAY] key to start the play operation.
- After the time display appears, press the [STOP] key to display the error code. (e.g. E-0)
- The error code display can be used as a repair guide showing which servo circuit is at fault. (See Error Code Based Troubleshooting.)

#### Error code based troubleshooting

※ The unit is satisfactory if the error code is E-0 of E-2.

※ Before testing, check that the test disc is free of scratches and dirt and optical pickup is clean.

FL error code display	Symptom	Probable cause	Signal to check		Normal the values of voltage and waveform	
			Signal name	Location	PLAY	STOP
E-1	Focus and tracking offset adjustments did not complete in the specified time period.	① Clocks X1 and X2, power supply VDD, and reset/RST, all on IC702 ② MDATA, MCLK, MLD, and SENSE signals to/from the mechanism controller	MDATA	IC702 ① pin		4.8V
			MCLK	IC702 ① pin		4.8V
			MLD	IC702 ① pin		4.8V
			SENSE	IC702 ① pin	0V	0V
			IRST	IC702 ① pin	4.9V	4.9V
			X1	IC702 ① pin		4.9V
E-3 E-5 E-7 E-8 E-D E-F	Disc play unstable	① Scratches or contaminants on disc surface ② Focus and tracking servo circuits (check waveforms, voltages, and part constants.) ③ Spindle driver circuit ④ Optical pickup	FE	IC702 ① pin		2.4V
			TE	IC702 ① pin		2.4V
			FOD	IC702 ① pin	2.4V	2.4V
			TRD	IC702 ① pin	2.4V	2.4V
			KICK	IC702 ① pin	2.4V	2.4V
			/FLOCK	IC702 ① pin	0V	4.9V
			/RF DET	IC702 ① pin	0V	4.8V
			RF	TJ701		3.4V
			STAT	IC702 ① pin	3.5V	0V
			FBAL	IC702 ① pin	2.5 ± 1.25V	2.5 ± 1.25V
E-4 E-6 E-C E-E	Best Eye (PD Balance) adjustment did not complete in the specified time period.	① Scratches or contaminants on disc surface ② Focus and Tracking servo circuit (check waveforms, voltages, and part constants.) ③ Optical pickup	RF	TJ701		3.4V
			FE	IC702 ① pin		0V
			/FLOCK	IC702 ① pin	0V	0V
			OFT	IC702 ① pin	0V	0V
E-8 E-A	Focus or Tracking gain adjustment did not complete in the specified time period.	① Scratches or contaminants on disc surface ② Focus and Tracking servo circuit (check waveforms, voltages, and part constants.) ③ Optical pickup	FE	IC702 ① pin		2.4V
			TE	IC702 ① pin		2.4V
			/FLOCK	IC702 ① pin	0V	0V
			OFT	IC702 ① pin	0V	0V

### Digital Servo System

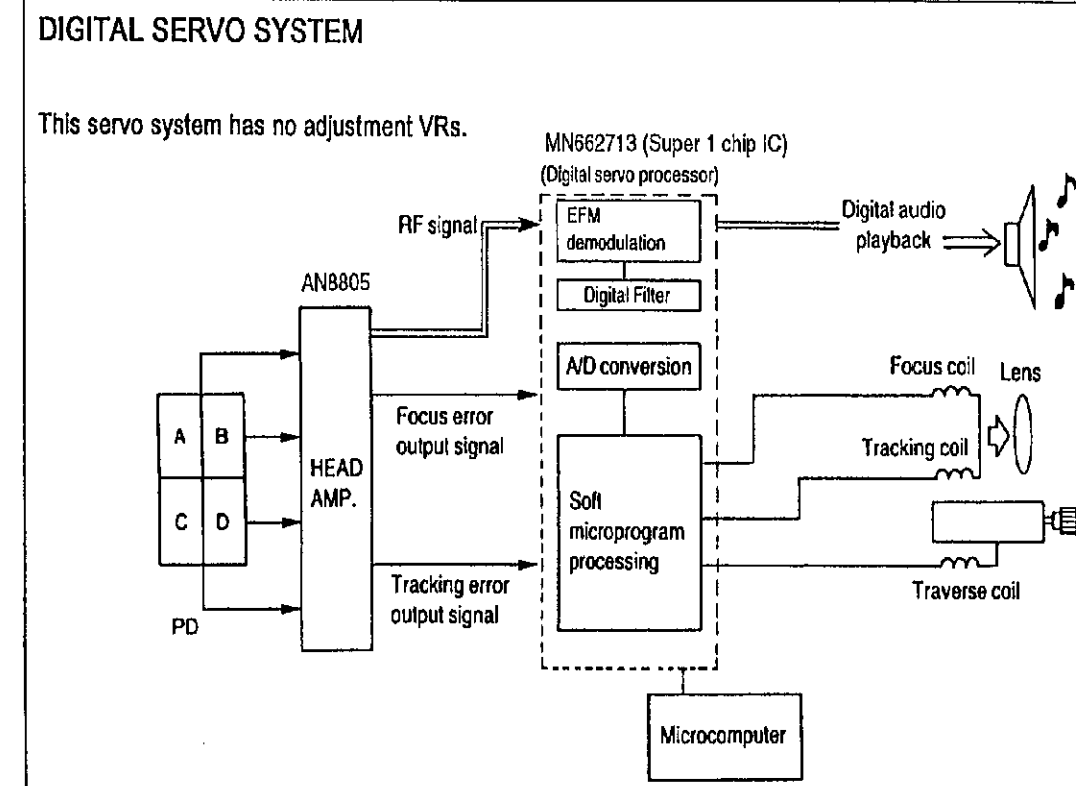

The following flow chart shows the sequence of automatic adjustments.

#### Flow chart on automatic adjustment sequence

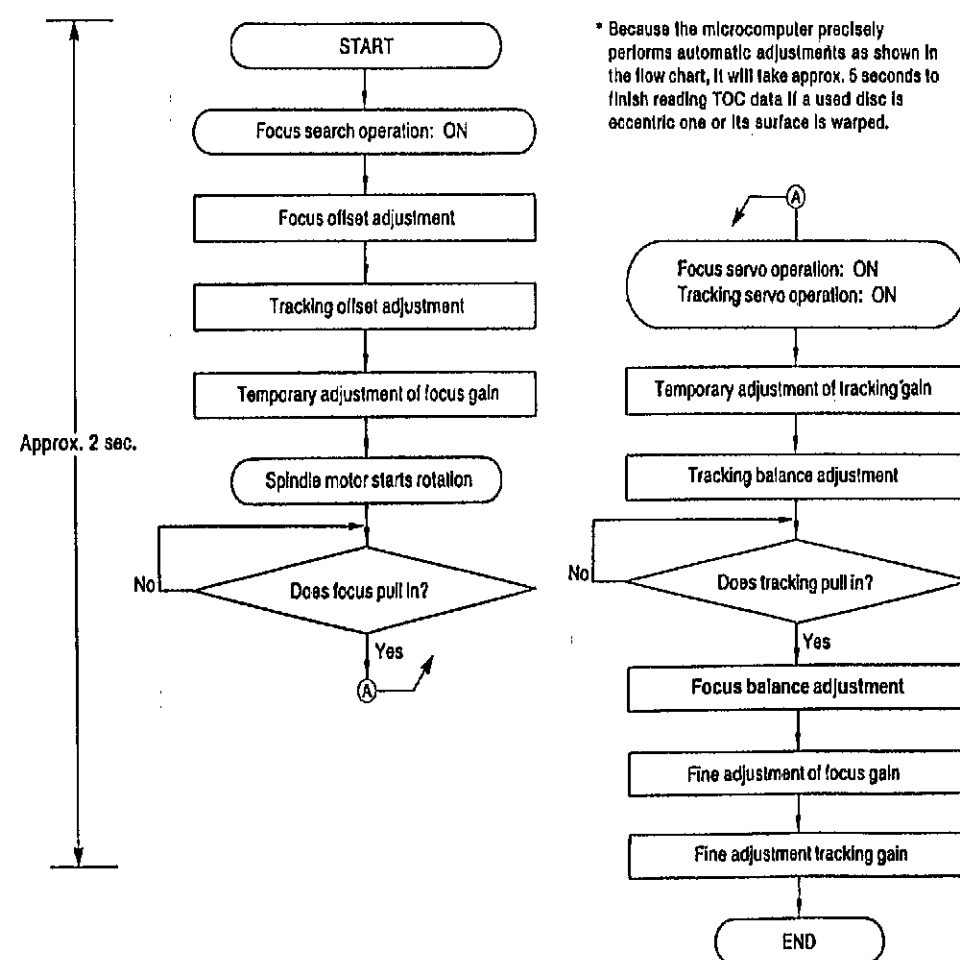

### Troubleshooting Guide

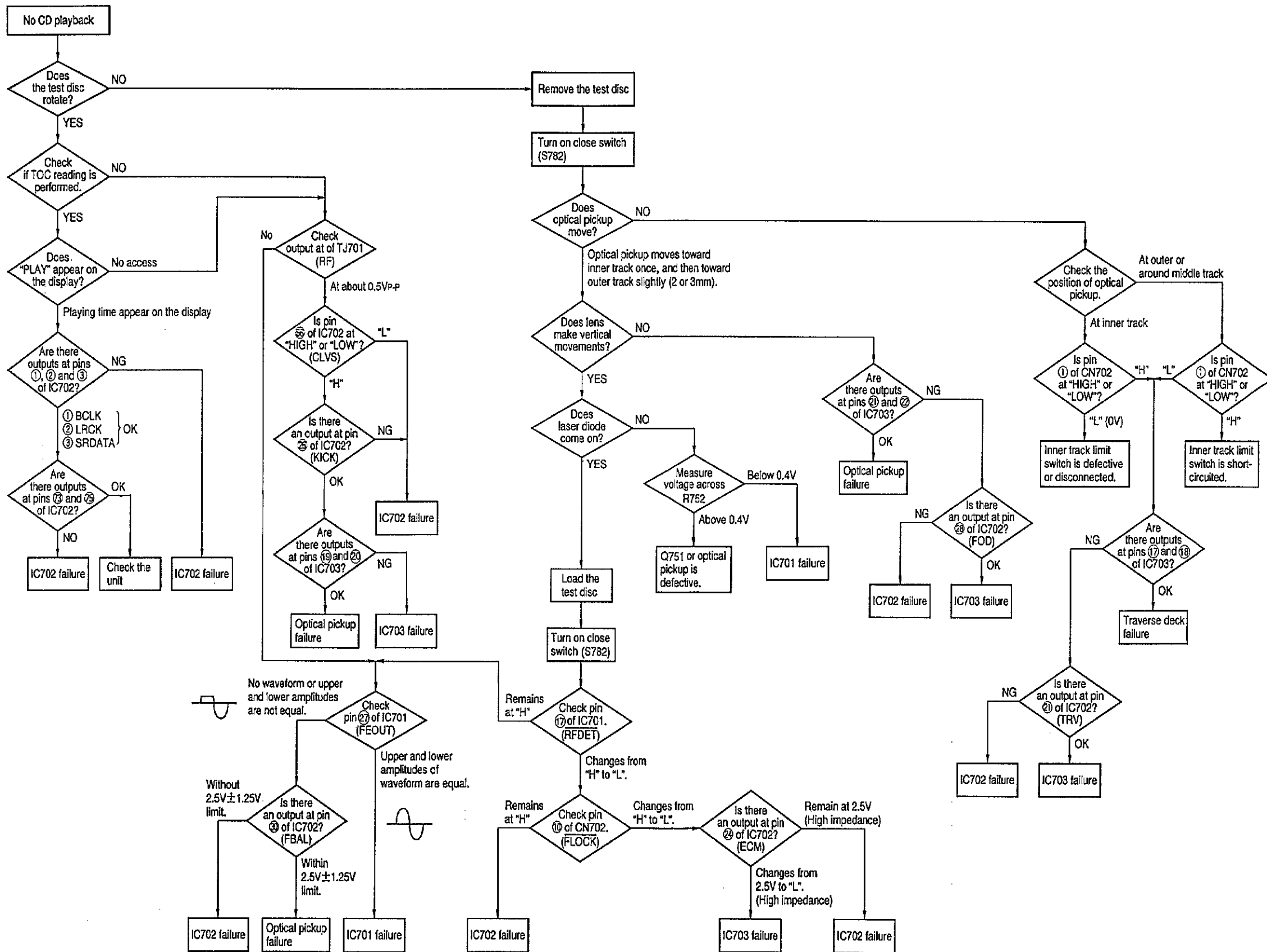

Function of IC Terminals

IC401 (UPD78042G063)

Table with 4 columns: Pin No., Terminal Name, I/O, Function. Lists 35 pins for IC401.

Table with 4 columns: Pin No., Terminal Name, I/O, Function. Lists 60 pins for IC701 (AN8805SBE1).

IC701 (AN8805SBE1)

IC702 (MN662713RG1)

Table with 4 columns: Pin No., Terminal Name, I/O, Function. Lists 36 pins for IC701.

Table with 4 columns: Pin No., Terminal Name, I/O, Function. Lists 31 pins for IC702.

IC702 Continued

Table with 4 columns: Pin No., Terminal Name, I/O, Function. Lists 35 pins for IC702 continued.

Replacement Parts List

Notes: Important safety notes: Components identified by Δ mark have special characteristics important for safety...

Table with columns: Ref. No., Part No., Part Name & Description, Remarks. Lists various components and their specifications.

Ref. No.	Part No.	Part Name & Description	Remarks
S617	EVQ21405R	SW, DISC LINK	
S619	EVQ21405R	SW, STOP	
S620	EVQ21405R	SW, F. SKIP	
S621	EVQ21405R	SW, R. SERACH	
S622	EVQ21405R	SW, RECALL	
S623	EVQ21405R	SW, SIDE A/B	
S624	EVQ21405R	SW, RANDOM	
S625	EVQ21405R	SW, TIME FADE	
S626	EVQ21405R	SW, OPEN/CLOSE	
S627	EVQ21405R	SW, PAUSE	
S628	EVQ21405R	SW, REPEAT	
S629	EVQ21405R	SW, CLEAR	
S630	EVQ21405R	SW, TAPE LENGTH	
S631	EVQ21405R	SW, TIME MODE	
S632	EVQ21405R	SW, PEAK SEARCH	
S635	EVQ21405R	SW, AUTO CUE	
S651	EVQ21405R	SW, POWER	
S781	RSH1A005	SW, TRAY OPEN DET.	
S782	RSH1A005	SW, TRAY CLOSE DET.	
		FUSE	
F1	XBA2C01TBO	FUSE, 250V T100mA	△
		JACK (S)	
		CONNECTOR (S)	
		SOCKET (6P)	
		SOCKET (23P)	
		CONNECTOR (6P)	
		CONNECTOR (20P)	[MB]
		CONNECTOR (20P)	[MB]
		SOCKET (12P)	[MB]
		SOCKET (23P)	
		CONNECTOR (6P)	
		CONNECTOR (6P)	
		CONNECTOR (6P)	
		SOCKET (7P)	[MB]
		SOCKET (7P)	[MB]
		EARTH PLATE	
GND871	RMCO184	EARTH PLATE	[MB]

Notes : \* Capacity values are in microfarads (uF) unless specified otherwise, P=Pico-farads (pF) F=Farads (F)  
 \* Resistance values are in ohms, unless specified otherwise, 1K=1,000 (OHM) , 1M=1,000k (OHM)

Ref. No.	Part No.	Values & Remarks	Ref. No.	Part No.	Values & Remarks	Ref. No.	Part No.	Values & Remarks		
RESISTORS										
R1	ERQ16NKR15E	1W 0.15	R764	ERDS2TJ393	1/4W 39K	C708	ECBT1C472MR5	16V 4700P		
R12, 13	ERDS2TJ102	1/4W 1K	R765	ERDS2TJ224T	1/4W 220K	C709	ECFR1C473KR	16V 0.047U		
R14	ERDS2TJ103	1/4W 10K	R766	ERDS2TJ104	1/4W 100K	C714	ECEAOJKA1011	6.3V 100U		
R15	ERDS2TJ822	1/4W 8.2K	R772, 773	ERDS2TJ220T	1/4W 22	C716	ECBT1H561KB5	50V 560P		
R16	ERDS2TJ680T	1/4W 68	R775, 776	ERDS2TJ392T	1/4W 3.9K	C717	ECFR1E104ZF5	25V 0.1U		
R17	ERDS2TJ471	1/4W 470	R777	ERDS2TJ102	1/4W 1K	C718	ECQV1H224JM3	50V 0.22U		
R18	ERDS2TJ473	1/4W 47K	R801, 802	ERDS2TJ104	1/4W 100K	C721, 722	ECBT1H270J5	50V 27P		
R19	ERDS2TJ472	1/4W 4.7K	R803	ERDS2TJ472	1/4W 4.7K	C723	ECEAOJKA221B	6.3V 220U		
R23	ERDS2TJ103	1/4W 10K	R804	ERDS2TJ470	1/4W 47	C724	ECFR1E104ZF5	25V 0.1U		
R24-27	ERDS2TJ1R0	1/4W 1.0	R805	ERDS2TJ472	1/4W 4.7K	C725, 726	ECBT1H102KB5	50V 1000P		
R28, 29	ERDS2TJ103	1/4W 10K	R807, 808	ERDS2TJ104	1/4W 100K	C727, 728	ECEA1HKA0101	50V 1U		
R30, 31	ERDS2TJ223	1/4W 22K	R809-812	ERDS2TJ224T	1/4W 220K	C730	ECFR1E104ZF5	25V 0.1U		
R51	ERDS2TJ331	1/4W 330	R813, 814	ERDS2TJ153	1/4W 15K	C731, 732	ECEAOJKA221B	6.3V 220U		
R52	ERDS2TJ272T	1/4W 2.7K	R815, 816	ERDS2TJ183T	1/4W 18K	C733	ECFR1E104ZF5	25V 0.1U		
R53, 54	ERDS2TJ472	1/4W 4.7K	R817, 818	ERDS2TJ153	1/4W 15K	C734	ECEA1AKA2211	10V 220U		
R401	ERDS2TJ102	1/4W 1K	R819, 820	ERDS2TJ471	1/4W 470	C735-737	ECBT1E223ZF	25V 0.022U		
R402	ERDS2TJ473	1/4W 47K	R821, 822	ERDS2TJ473	1/4W 47K	C738	ECFR1C183KR	16V 0.018U		
R403, 404	ERDS2TJ103	1/4W 10K	R823, 824	ERDS2TJ331	1/4W 330	C739	ECBT1C152MR5	16V 1500P		
R405, 406	ERDS2TJ471	1/4W 470	R825, 826	ERDS2TJ102	1/4W 1K	C740	ECBT1C272MR5	16V 2700P		
R407	ERDS2TJ101	1/4W 100	R851	ERDS2TJ471	1/4W 470	C742	ECFR1C273KR	16V 0.027U		
R408-411	ERDS2TJ103	1/4W 10K	R852	ERDS2TJ222	1/4W 2.2K	C743	ECBT1E223ZF	25V 0.022U		
R601, 602	ERDS2TJ100	1/4W 10	R871, 872	ERDS2TJ473	1/4W 47K	C744	ECBT1C822MS5	16V 8200P		
R651	ERDS2TJ221	1/4W 220	R873-876	ERDS2TJ104	1/4W 100K	C747, 748	ECBT1C103NS5	16V 0.01U		
R701	ERDS2TJ561	1/4W 560	R885, 886	ERDS2TJ222	1/4W 2.2K	C751	ECEA1CKA1001	16V 10U		
R703	ERDS2TJ823T	1/4W 82K	R887, 888	ERDS2TJ101	1/4W 100	C752	ECFR1E104ZF5	25V 0.1U		
R707, 708	ERDS2TJ334	1/4W 330K	R889, 890	ERDS2TJ472	1/4W 4.7K	C755	ECBT1H331KB5	50V 330P		
R709	ERDS2TJ683	1/4W 68K	CAPACITORS					C766	ECBT1H391KB5	50V 390P
R711	ERDS2TJ154	1/4W 150K	C1	ECFD103KXL	50V 0.01U	C767	ECEA1HKN0101	50V 1U		
R712	ERDS2TJ221	1/4W 220	C10	ECFR1E104ZF5	25V 0.1U	C768	ECFR1E682KR	25V 6800P		
R717, 718	ERDS2TJ102	1/4W 1K	C11	ECA1CM222B	16V 2200U △	C769	ECBT1C222MR5	16V 2200P		
R721	ERDS2TJ101	1/4W 100	C12	ECBT1C103NS5	16V 0.01U	C772-775	ECFR1E104ZF5	25V 0.1U		
R722	ERDS2TJ683	1/4W 68K	C13	ECEA1AKA330B	10V 33U	C776	ECBT1H180J5	50V 18P		
R723	ERDS2TJ183T	1/4W 18K	C14	ECEAOJKA470B	6.3V 47U	C777	ECBT1H680J5	50V 68P		
R724	ERDS2TJ393	1/4W 39K	C15	ECEA1EU101	25V 100U △	C781	ECEA1AKA1011	10V 100U		
R725	ERDS2TJ472	1/4W 4.7K	C16	ECEA1EU331	25V 330U 1	C801, 802	ECBT1H180J5	50V 18P		
R726	ERDS2TJ474	1/4W 470K	C17, 18	ECEA1HU101	50V 100U	C803, 804	ECBT1H102KB5	50V 1000P		
R727	ERDS2TJ153	1/4W 15K	C19-21	ECEA1EU101	25V 100U	C805, 806	ECBT1H121KB5	50V 120P		
R728	ERDS2TJ822	1/4W 8.2K	C22	ECEA1AU331	10V 330U	C811, 812	ECEA1HKA010B	50V 1U		
R731	ERDS2TJ223	1/4W 22K	C51	ECEA1AKA220B	10V 22U	C813, 814	ECEAOJKA470B	6.3V 47U		
R732	ERDS2TJ183T	1/4W 18K	C401	ECFR1E104ZF5	25V 0.1U	C815, 816	ECBT1H102KB5	50V 1000P		
R733	ERDS2TJ822	1/4W 8.2K	C402	ECEAOJU102	6.3V 1000U	C817	ECFR1E104ZF5	25V 0.1U		
R735, 736	ERDS2TJ101	1/4W 100	C404	ECFR1E104ZF5	25V 0.1U	C831	ECEAOJKA470B	6.3V 47U		
R745	ERDS2TJ155	1/4W 1.5M	C405	ECEAOJKA101B	6.3V 100U	C833	ECFR1E104ZF5	25V 0.1U		
R751	ERDS2TJ681	1/4W 680	C703	ECEAOJKA1011	6.3V 100U	C851	ECEAOJU471	6.3V 470U		
R752, 753	ERDS2TJ392T	1/4W 3.9K	C704	ECFR1E104ZF5	25V 0.1U	C871, 872	ECEA1EN3R3B	25V 3.3U		
R754	ERDS2TJ103	1/4W 10K	C705	ECEA1HKA0101	50V 1U	C873, 874	ECQBT1H03JF3	50V 0.01U		
R761, 762	ERDS2TJ103	1/4W 10K	C706	ECBT1H101KB5	50V 100P	C875-880	ECBT1C103NS5	16V 0.01U		
R763	ERDS2TJ823T	1/4W 82K	C707	ECFR1C273KR	16V 0.027U	C881, 882	ECEA1AW101XB	10V 100U		

■ Cabinet Parts Location

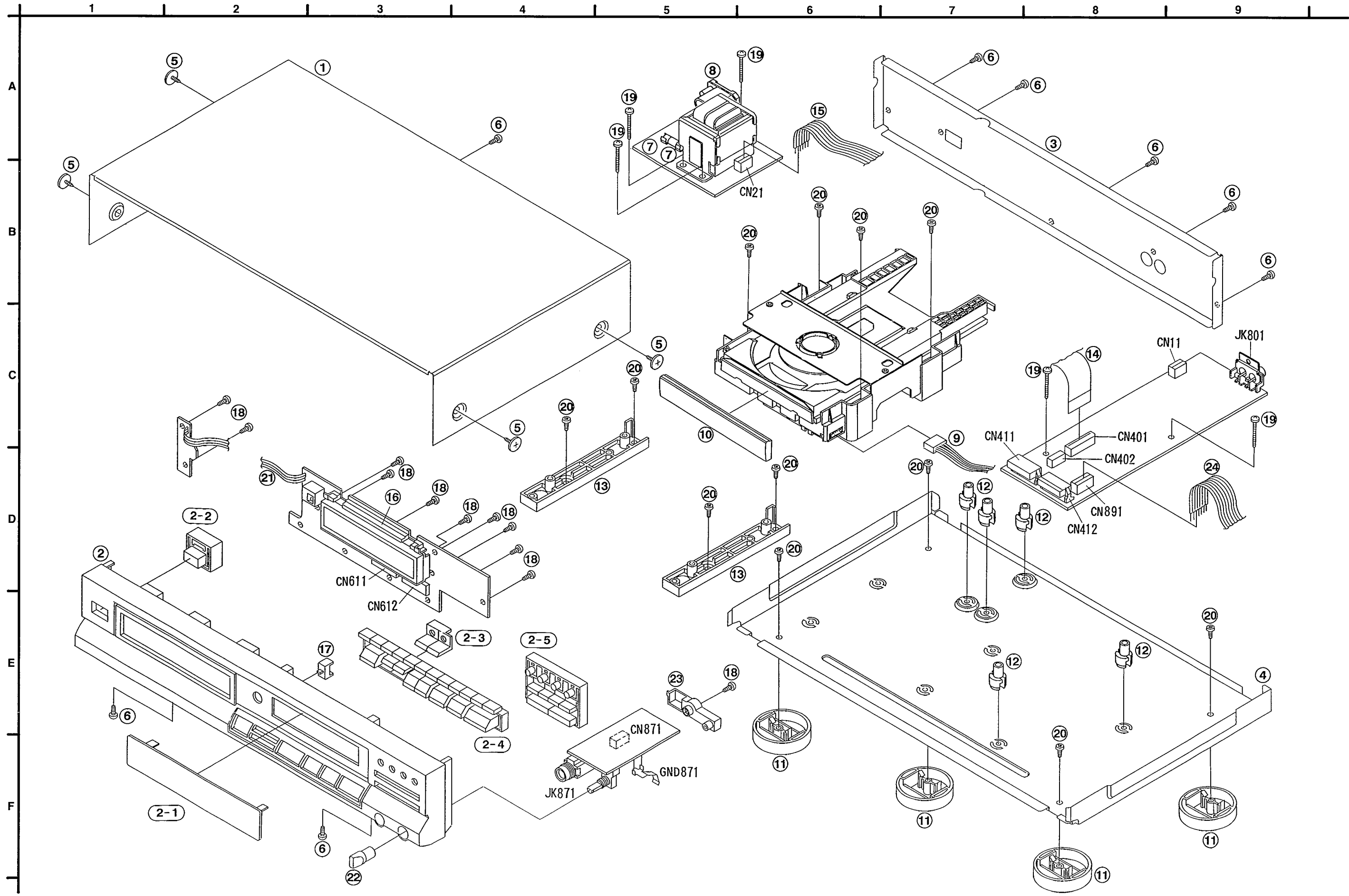

# Loading Unit Parts Location

1 | 2 | 3 | 4 | 5

**Note:**

When changing mechanism parts, apply the specified grease to areas marked "xx" as shown in the drawing.

Ref No.	Part No.
①	RFKXEM30L

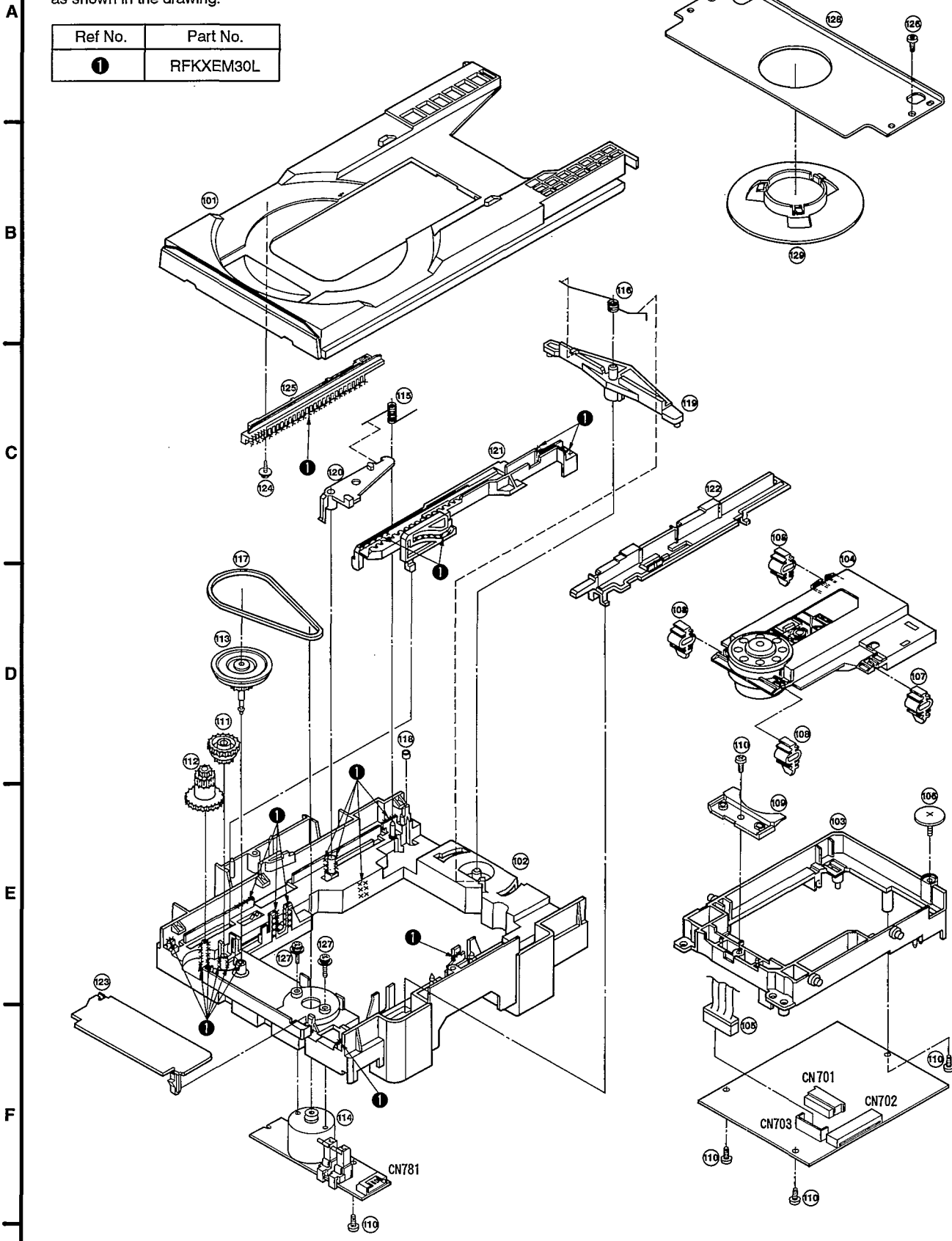

Ref. No.	Part No.	Part Name & Description	Remarks
		CABINET PARTS	
1	RKMO098-K	CABINET	[MB]
2	RFKGLPG460AE	FRONT PANEL ASS'Y	[MB]
2-1	RKWO245C-R	WINDOW	[MB]
2-2	RGU1029-K	POWER BUTTON	[MB]
2-3	RFKNLPG460AD	MAIN BUTTON A	[MB]
2-4	RFKNLPG460AE	MAIN BUTTON B	[MB]
2-5	RGU0808-K	SUB BUTTON	[MB]
3	RFKHLPG460AE	REAR PANEL ASS'Y	[MB] (E) (EG)
3	RFKHLPG460AB	REAR PANEL ASS'Y	[MB] (EB)
4	RMKO178-1	BOTTOM CHASSIS	[MB]
5	RHD30035-K	SCREW	
6	XTBS3+8JFZ1	SCREW	
7	EYF52BC	FUSE HOLDER	
8	SJS9236	AC INLET (JK1)	△
9	REX0577	CABLE ASS'Y	[MB]
10	RGKO616-K	TRAY LID	[MB]
11	RKAO040B	FOOT	[MB]
12	RMRO377-1	PCB SUPPORT	[MB]
13	RMRO718-W	MECHANISM SPACER	[MB]
14	RWJ5223180EE	FPC	[MB]
15	RWJ6406180XX	FLAT CABLE	[MB]
16	RMRO659-K	FL HOLDER	[MB]
17	RGL0228-Q	LED INDICATOR	[MB]
18	XTBS26+8J	SCREW	
19	XTB3+20JFR	SCREW	
20	XTB3+8JFZ	SCREW	
21	RWJ6403200XX	FLAT CABLE (FC651)	[MB]
22	RGW0048	H. P. VOLUMEKNOB	
23	RMRO610-K	H. P. P. C. B. HOLDER	[MB]
24	RWJ6407100XX	FLAT CABLE	[MB]
		LOADING UNIT PARTS	
101	RGQ0130-K	TRAY	[MB]
102	RFKJLPG460AE	MECHANISM CHASSIS ASS'Y	[MB]
103	RMRO719-W	MID CHASSIS	[MB]
104	RAE1100Z	TRAVERSE UNIT	[MB]
105	REX0576	CABLE ASS'Y	[MB]
106	RHD30047	SCREW	[MB]
107	RMGO337-K	DAMPING RUBBER	[MB]
108	RMGO337-Q	DAMPING RUBBER	[MB]
109	RMRO750-W	STOPPER	[MB]
110	XTBS26+8J	SCREW	
111	RDGO142	RELAY GEAR	
112	RDGO259	DRIVE GEAR	[MB]
113	RDPO065	RELAY PULLY	
114	REMO047	MOTOR ASS'Y	[MB]
115	RME0063	LOCK LEVER SPRING	
116	RME0087	ASSIST SPRING	

Ref. No.	Part No.	Part Name & Description	Remarks
117	RMGO158	BELT	
118	RMGO338-Q	STOPPER RUBBER	[MB]
119	RML0177	CHANGE LEVER	
120	RML0178-1	LOCK LEVER	
121	RMM0112	SLIDER 1	[MB]
122	RMM0113	SLIDER 2	[MB]
123	RMRO721-K	GEAR COVER	[MB]
124	RHD20009-1	SCREW	
125	RFKNLPG460AA	DRIVE RACK ASS'Y	[MB]
126	XTB3+8JFZ	SCREW	
127	XYN2+F6FZ	SCREW	
128	RFKNLPG460AB	CLAMP BASE ASS'Y	[MB]
129	RFKNLPG460AC	CLAMPER ASS'Y	[MB]
		PACKING MATERIALS	
P1	RPG1905	PACKING CASE	[MB]
P2	RPN0647	CUSHION	[MB]
P3	XZB23X35C03	PROTECTION BAG	
P4	XZB60X65A01Z	PROTECTION BAG	
		ACCESSORIES	
A1	EUR642100	REMOTE CONTROL TRANSMITTER	[MB]
A1-1	UR64EC1326	BATTERY COVER	[MB]
A2	RJA0043-C	AC POWER CORD	△ (E, EG) [MB]
A2	RJA0034-P	AC POWER CORD	△ (EB) [MB]
A3	RFKSLPG360AE	INSTRUCTIONS MANUAL	(E) [MB]
A3	RQT2226-B	INSTRUCTIONS MANUAL	(EB) [MB]
A3	RFKSLPG360AG	INSTRUCTIONS MANUAL	(EG) [MB]
A4	SJP2249-3	STEREO PIN CORD	
A5	RQA0013	WARRANTY CARD	
A6	RQCB0169	SERVICE CENTER LIST	

## ■Packaging

