

# Service Manual

Compact Disc Player

Compact Disc Player

SL-PG480A



Colour

(K) : Black

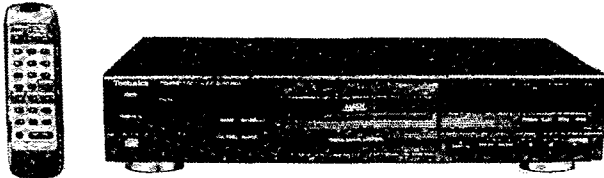

## Areas

Suffix for Model No.	Area	Colour
(E)	Europe	(K)
(EB)	Britain	
(EG)	Germany and Italy	

## RAE1100Z MECHANISM SERIES

## Specifications

## ■ Audio

No. of channels	2 (left and right, stereo)
Frequency response	2 – 20,000 Hz, ± 1 dB
Output voltage	2 V (at 0 dB)
Dynamic range	92 dB
S/N	100 dB
Harmonic distortion	0.005% (1 kHz, 0 dB)
Total harmonic distortion	0.007% (1 kHz, 0 dB)
Wow and flutter	Below measurable limit
DA converter	MASH (1 bit)
Output impedance	1 kΩ
Load impedance	More than 10 kΩ

## ■ Pickup

Wavelength	780 nm
Laser Power	No hazardous radiation is emitted (with safety protection)

## ■ General

Power consumption	13 W
Power supply	AC 50/60 Hz, 230 – 240 V
Dimensions (W × H × D)	430 × 92 × 283 mm
Weight	3.1 kg

## Note:

Specifications are subject to change without notice.  
Weight and dimensions are approximate.

## For United Kingdom only:

This apparatus was produced to BS 800.

\*

• MASH is a trademark of NTT.

## ⚠ WARNING

This service information is designed for experienced repair technicians only and is not designed for use by the general public. It does not contain warnings or cautions to advise non-technical individuals of potential dangers in attempting to service a product. Products powered by electricity should be serviced or repaired only by experienced professional technicians. Any attempt to service or repair the product or products dealt with in this service information by anyone else could result in serious injury or death.

# Technics®

© 1996 Matsushita Electric Industrial Co., Ltd.  
All rights reserved. Unauthorized copying  
and distribution is a violation of law.

## ■ Contents

	Page		Page
Handling Precautions for Traverse Deck .....	2	Schematic Diagram .....	15~19
Precaution of Laser Diode .....	2, 3	Printed Circuit Board Diagram .....	20, 21
Accessories .....	3	Wiring Connection Diagram .....	22
Connections .....	3	Function of IC Terminals .....	23~25
Caution for AC Mains Lead .....	4	Block Diagram .....	26, 27
Front Panel Controls .....	5	Troubleshooting Guide .....	28, 29
Sequential Play .....	6	Replacement Parts List .....	30, 31, 35
Operation Check and		Cabinet Parts Location .....	33, 33
Main Component Replacement Procedures .....	7~13	Loading Unit Parts Location .....	34
Automatic Adjustment Results Display Function .....	14	Packaging .....	35

## ■ Handling Precautions for Traverse Deck

The laser diode in the traverse deck (optical pickup) may break down due to potential difference caused by static electricity of clothes or human body. So, be careful of electrostatic breakdown during repair of the traverse deck (optical pickup).

### ● Handling of traverse deck (optical pickup)

1. Do not subject the traverse deck (optical pickup) to static electricity as it is extremely sensitive to electrical shock.
2. To prevent the breakdown of the laser diode, an anti-static shorting pin is inserted into the flexible board (FFC board).  
When removing or connecting the short pin, finish the job in as short time as possible.
3. Take care not to apply excessive stress to the flexible board (FFC board).
4. Do not turn the variable resistor (laser power adjustment). It has already been adjusted.

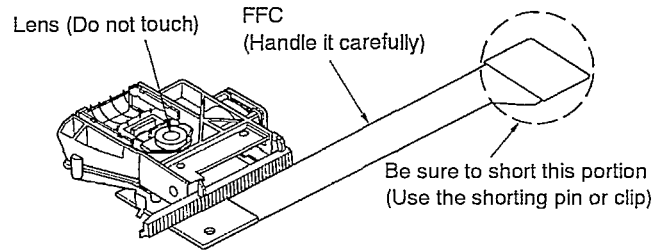

### ● Grounding for electrostatic breakdown prevention

1. Human body grounding  
Use the anti-static wrist strap to discharge the static electricity from your body.
2. Work table grounding  
Put a conductive material (sheet) or steel sheet on the area where the traverse deck (optical pickup) is placed, and ground the sheet.

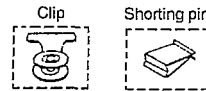

#### Caution:

The static electricity of your clothes will not be grounded through the wrist strap. So, take care not to let your clothes touch the traverse deck (optical pickup).

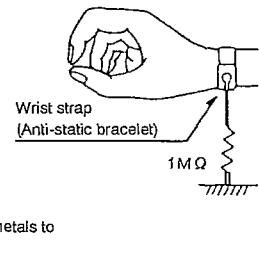
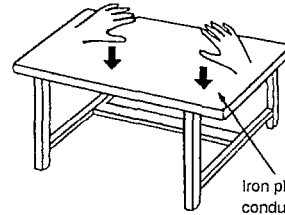

## ■ Precaution of Laser Diode

**CAUTION:** This product utilizes a laser diode with the unit turned "on", invisible laser radiation is emitted from the pick up lens.  
Wave length: 780 nm  
Maximum output radiation power from pick up: 100 μW/VDE

Laser radiation from the pick up unit is safety level, but be sure the followings:

1. Do not disassemble the pick up unit, since radiation from exposed laser diode is dangerous.
2. Do not adjust the variable resistor on the pick up unit. It was already adjusted.
3. Do not look at the focus lens using optical instruments.
4. Recommend not to look at pick up lens for a long time.

**ACHTUNG:** Dieses produkt enthält eine laserdiode. Im eingeschalteten zustand wird unsichtbare laserstrahlung von der lasereinheit adgestrahlt.  
Wellenlänge: 780 nm  
Maximale strahlungsleistung der laserinheit: 100 μW/VDE

Die strahlung an der lasereinheit ist ungefährlich, wenn folgende punkte beachtet werden:

1. Die lasereinheit nicht zerlegen, da die strahlung an der freigelegten laserdiode gefährlich ist.
2. Den werksseitig justierten einstellregler der lasereinheit nicht verstellen.
3. Nicht mit optischen instrumenten in die fokussierlinse blicken.
4. Nicht über längere zeit in die fokussierlinse blicken.

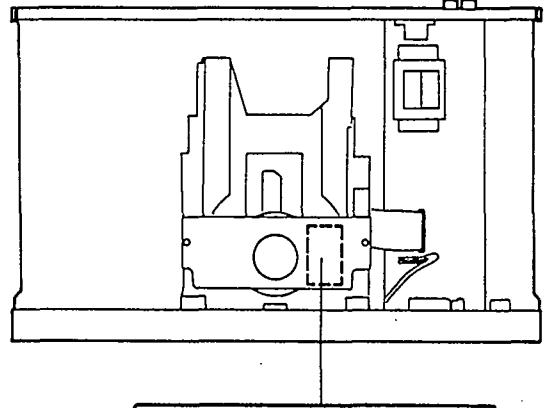
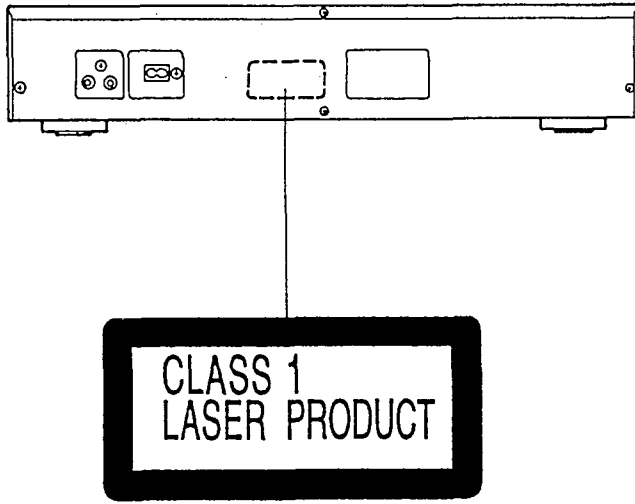

<b>DANGER</b>	INVISIBLE LASER RADIATION WHEN OPEN. AVOID DIRECT EXPOSURE TO BEAM.
<b>ADVARSEL</b>	USYNLIG LASERSTRÅLING VED ÅBNING. UNDGÅ UDSÆTTELSE FOR STRÅLING.
<b>VARO!</b>	AVATTIASSA JA SUOJALUKITUS OHTIETTAESSA OLET ALLTIIHÄ HÄKYMÄTÖNÄ LASERSÄTEERVILLE. ÄLÄ KATSO SÄTEESEEN.
<b>VARNING</b>	OSYNLIG LASERSTRÅLING NÄR DENNA DEL ÄR ÖPPNAD OCH SPÄRREN ÄR URKOPPLAD. BETRÄKTA EJ STRÅLEN.
<b>ADVARSEL</b>	USYNLIG LASERSTRÅLING NÄR DEKSEL ÅPNES OG SIKKERHEDSLÅS BRYES. UNDGÅ EKSPONERING FOR STRÅLEN.
<b>VORSICHT</b>	UNSIHTBARE LASERSTRAHLUNG, WENN ABDECKUNG GEÖFFNET. NICHT DEM STRAHLE AUSSETZEN. HOLSORD1-1

## Accessories

AC mains lead ..... 1 pc.  
 (For United Kingdom: RJA0044-C) (For others: RJA0043-C)



Remote control ..... 1 pc.  
 (EUR643900)

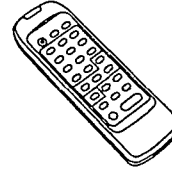

Stereo connection cable ..... 1 pc.  
 (SJP2249-3)

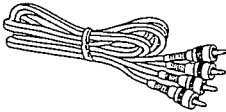

Battery for remote control ..... 2 pcs.  
 (UM-4, AAA, R03)

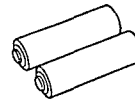

## Connections

Before making connections, be sure that the power of this unit and all other system components is first turned off.

**Note**

Although the figure below shows the AC mains lead being connected to a household mains outlet, if the amplifier (or receiver) is equipped with a mains outlet, connect the lead to that outlet.

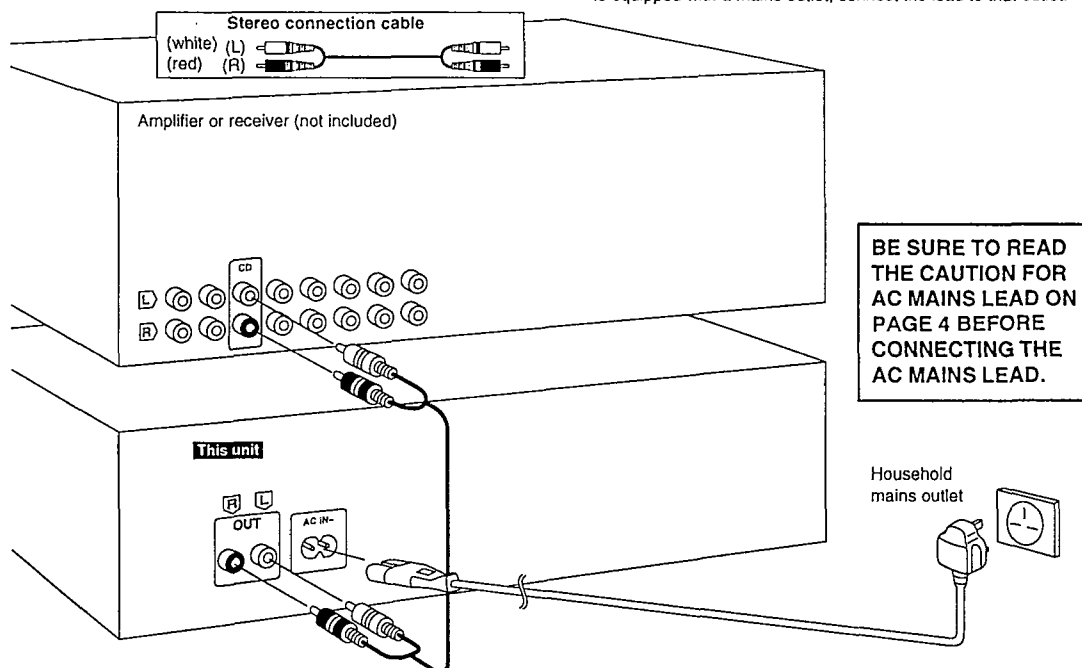

## ■ Caution for AC Mains Lead

### (For United Kingdom)



("EB" area code model only)

For your safety, please read the following text carefully.

This appliance is supplied with a moulded three pin mains plug for your safety and convenience.

A 5-ampere fuse is fitted in this plug.

Should the fuse need to be replaced please ensure that the replacement fuse has a rating of 5-ampere and that it is approved by ASTA or BSI to BS1362.

Check for the ASTA mark  or the BSI mark  on the body of the fuse.

If the plug contains a removable fuse cover you must ensure that it is refitted when the fuse is replaced.

If you lose the fuse cover the plug must not be used until a replacement cover is obtained.

A replacement fuse cover can be purchased from your local dealer.

#### CAUTION!

IF THE FITTED MOULDED PLUG IS UNSUITABLE FOR THE SOCKET OUTLET IN YOUR HOME THEN THE FUSE SHOULD BE REMOVED AND THE PLUG CUT OFF AND DISPOSED OF SAFELY.

THERE IS A DANGER OF SEVERE ELECTRICAL SHOCK IF THE CUT OFF PLUG IS INSERTED INTO ANY 13-AMPERE SOCKET.

If a new plug is to be fitted please observe the wiring code as shown below.

If in any doubt please consult a qualified electrician.

#### IMPORTANT

If the socket outlets in the home are not suitable for the plug supplied with this appliance it should be cut off and an appropriate three pin plug fitted.

The wires in this mains lead are coloured in accordance with the following code:

Blue: Neutral

Brown: Live

Do not connect either wire to the earth terminal in the plug which is marked by the letter "E" or by the safety earth symbol  or coloured green or green-and-yellow.

As the colours of the wires in the mains lead of this apparatus may not correspond with the coloured markings identifying the terminals in your plug proceed as follows. The wire which is coloured BLUE must be connected to the terminal which is marked with the letter N or coloured BLACK.

The wire which is coloured BROWN must be connected to the terminal which is marked with the letter L or coloured RED.

#### Before use

Remove the connector cover as follows.

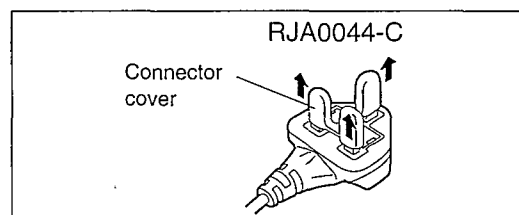

#### How to replace the fuse

1. Open the fuse cover with a screwdriver.

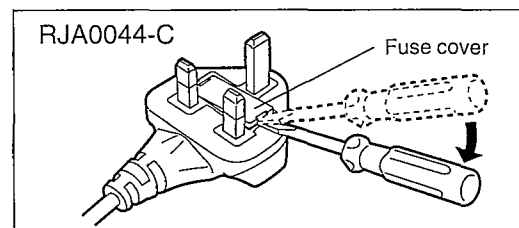

2. Replace the fuse and close or attach the fuse cover.

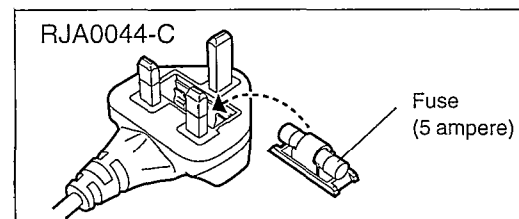

## ■ Front Panel Controls

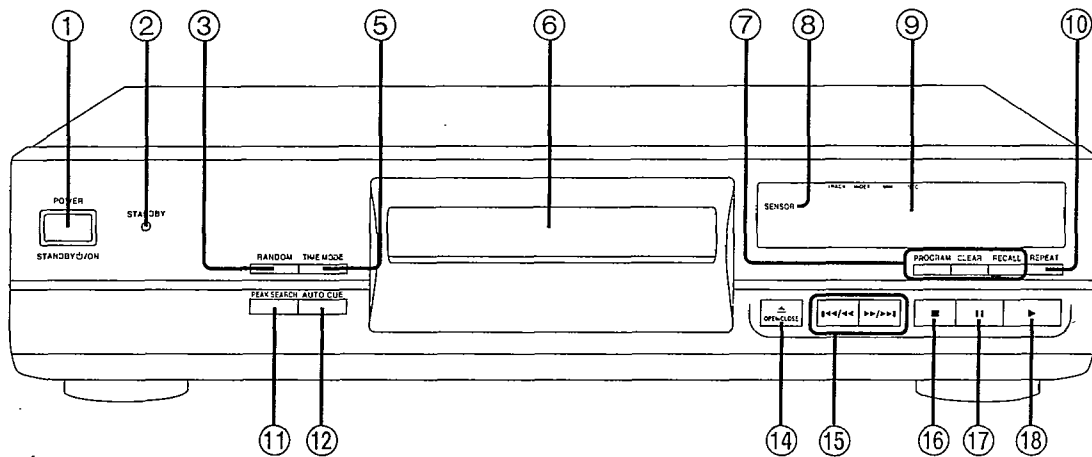

No.	Name
①	<b>Power "STANDBY ⏻/ON" switch (POWER, STANDBY ⏻/ON)</b> Press to switch the unit from on to standby mode or vice versa. In standby mode, the unit is still consuming a small amount of power.
②	<b>Standby indicator (STANDBY)</b> When the unit is connected to the AC mains supply, this indicator lights up in standby mode and goes out when the unit is turned on.
③	<b>Random play button (RANDOM)</b>
④	<b>Time mode select button (TIME MODE)</b>
⑤	<b>Disc tray</b>
⑦	<b>Program play buttons</b> <ul style="list-style-type: none"> <li>● Program button (PROGRAM)</li> <li>● Clear button (CLEAR)</li> <li>● Recall button (RECALL)</li> </ul>

No.	Name
⑧	<b>Remote control signal sensor (SENSOR)</b>
⑨	<b>Display panel</b>
⑩	<b>Repeat button (REPEAT)</b>
⑪	<b>Peak search button (PEAK SEARCH)</b>
⑫	<b>Auto cue button (AUTO CUE)</b>
⑭	<b>Disc tray open/close button (▲ OPEN/CLOSE)</b>
⑮	<b>Skip/Search buttons (I◀◀/◀◀, ▶▶/▶▶I)</b>
⑯	<b>Stop button (■)</b>
⑰	<b>Pause button (II)</b>
⑱	<b>Play button (▶)</b>

# Sequential Play

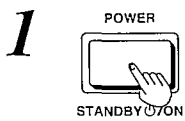
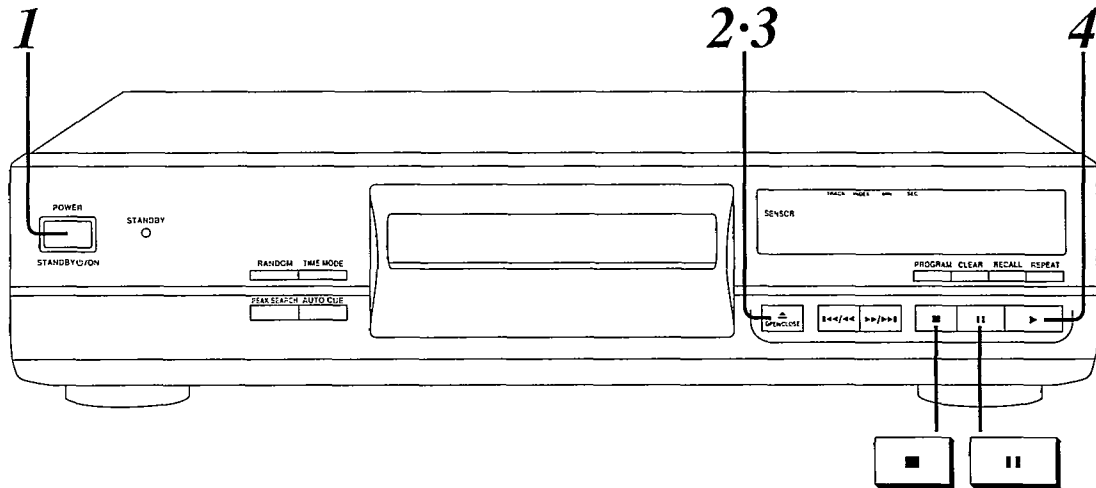

Press **POWER** (Power goes on).

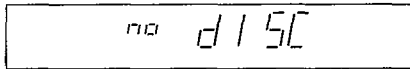

- This indicates that a CD has not been installed.
- If a CD is already in the disc tray, it automatically begins playing from the first track.



Press **▲ OPEN/CLOSE** to open the tray and insert a disc.

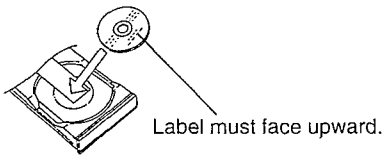

Press **▲ OPEN/CLOSE** to close the tray.

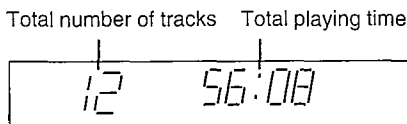

Press **▶ (Play begins)**.  
Play stops automatically after all tracks have been played.

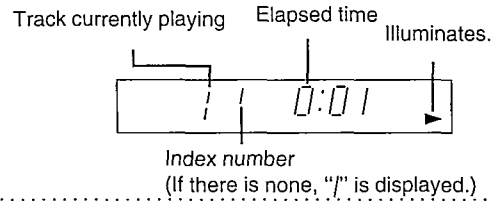

To stop the disc play:



To temporarily stop the disc play:

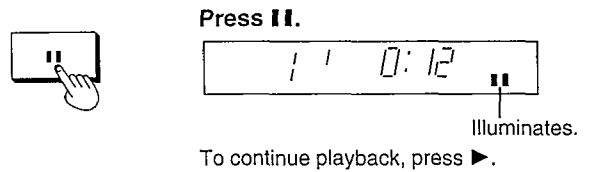

**Notes**

- The displayed total playing time includes the time between tracks. For this reason, the time may be several seconds longer than that which appears on song cards and the like.
- When you use the timer with other unit, be sure to turn this unit on.

**For your reference:**

- If you skip step 3 and press **▶**, the tray automatically closes and play begins from the first track.

## ■ Operation Check and Main Component Replacement Procedures

**Warning:** This product uses a laser diode. Refer to caution statements on page 2.

**ACHTUNG:** • Die lasereinheit nicht zerlegen.

• Die lasereinheit darf nur gegen eine vom hersteller speziferte einheit ausgetauscht werden.

**“ATTENTION SERVICER”** Some chassis components may have sharp edges. Be careful when disassembling and servicing.

### NOTE

1. This section describes procedures for checking the operation of the major printed circuit boards and replacing the main components.
2. For reassembly after operation checks or replacement, reverse the respective procedures. Special reassembly procedures are described only when required.
3. Select items from the following index when checks or replacement are required.
4. Illustrated screws are equivalent to actual size.
5. Refer the parts No. on the page of “Main Component Replacement Procedures”, if necessary.

### • Contents

#### • Checking Procedure for each P.C.B.

1. Checking for the main P.C.B. and operation P.C.B..	Page 7,8.
2. Checking for the servo P.C.B..	9.

#### • Main Component Replacement Procedures

1. Replacement for the traverse unit ass'y.	10-12.
2. Replacement for the loading belt and loading motor.	13.

## ■ Checking Procedure for each P.C.B.

### 1. Checking for the main P.C.B. and operation P.C.B.

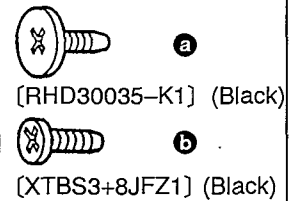
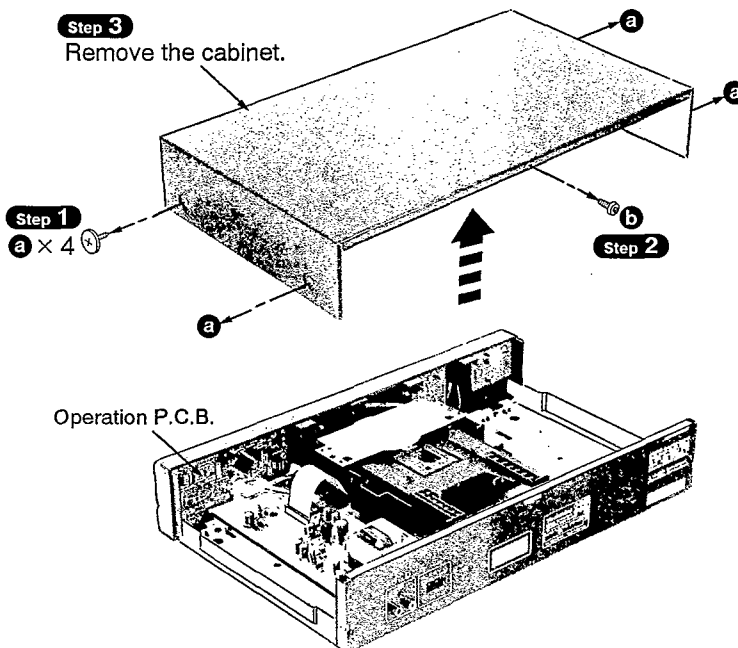

• Check the operation P.C.B. in this condition.

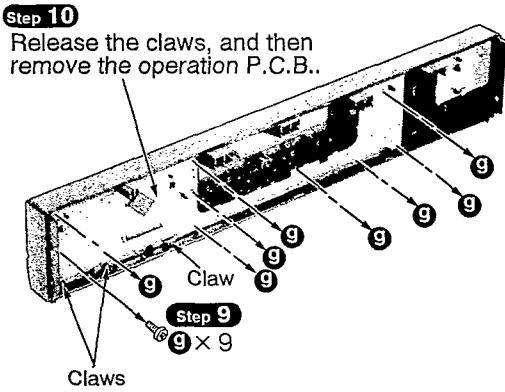
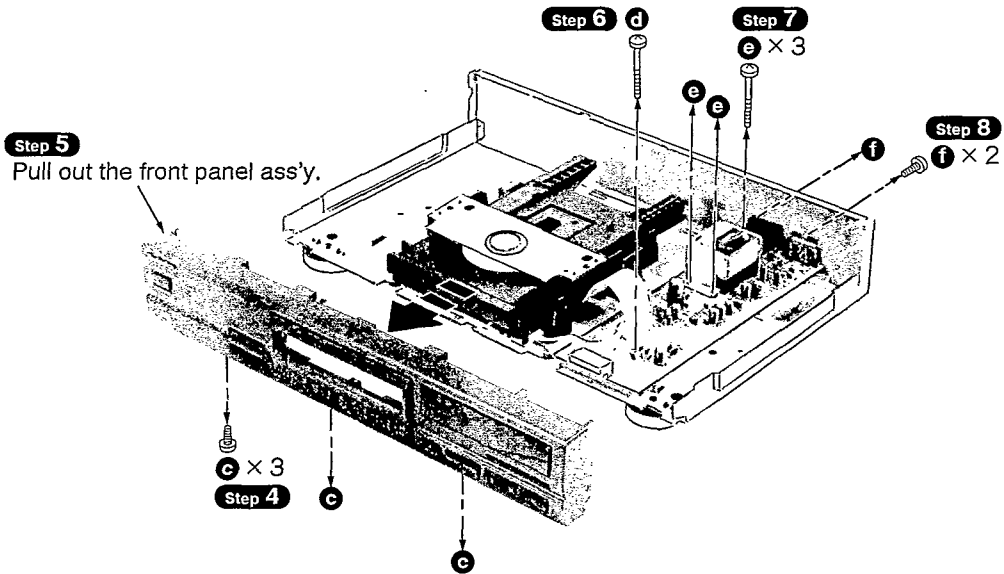

**NOTE**  
In order to stand the operation P.C.B., place a box under the unit.

• Check the main P.C.B. as shown below.

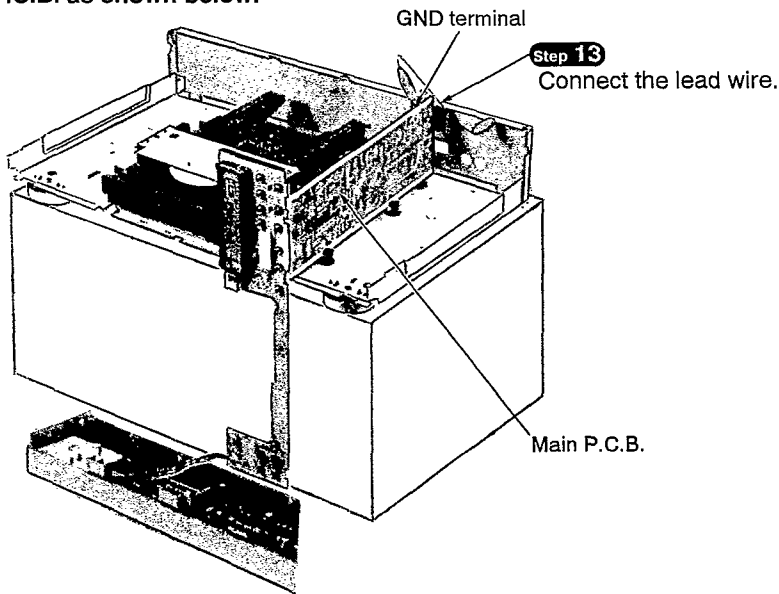

- c**  
[XTB3+10JFZ] (Black)
- d**  
[XTBR3+20JFZ] (Black)
- e**  
[RHD30053]
- f**  
[XTBS3+8JFZ1] (Black)
- g**  
[RHD26021]



2. Checking for the servo P.C.B.

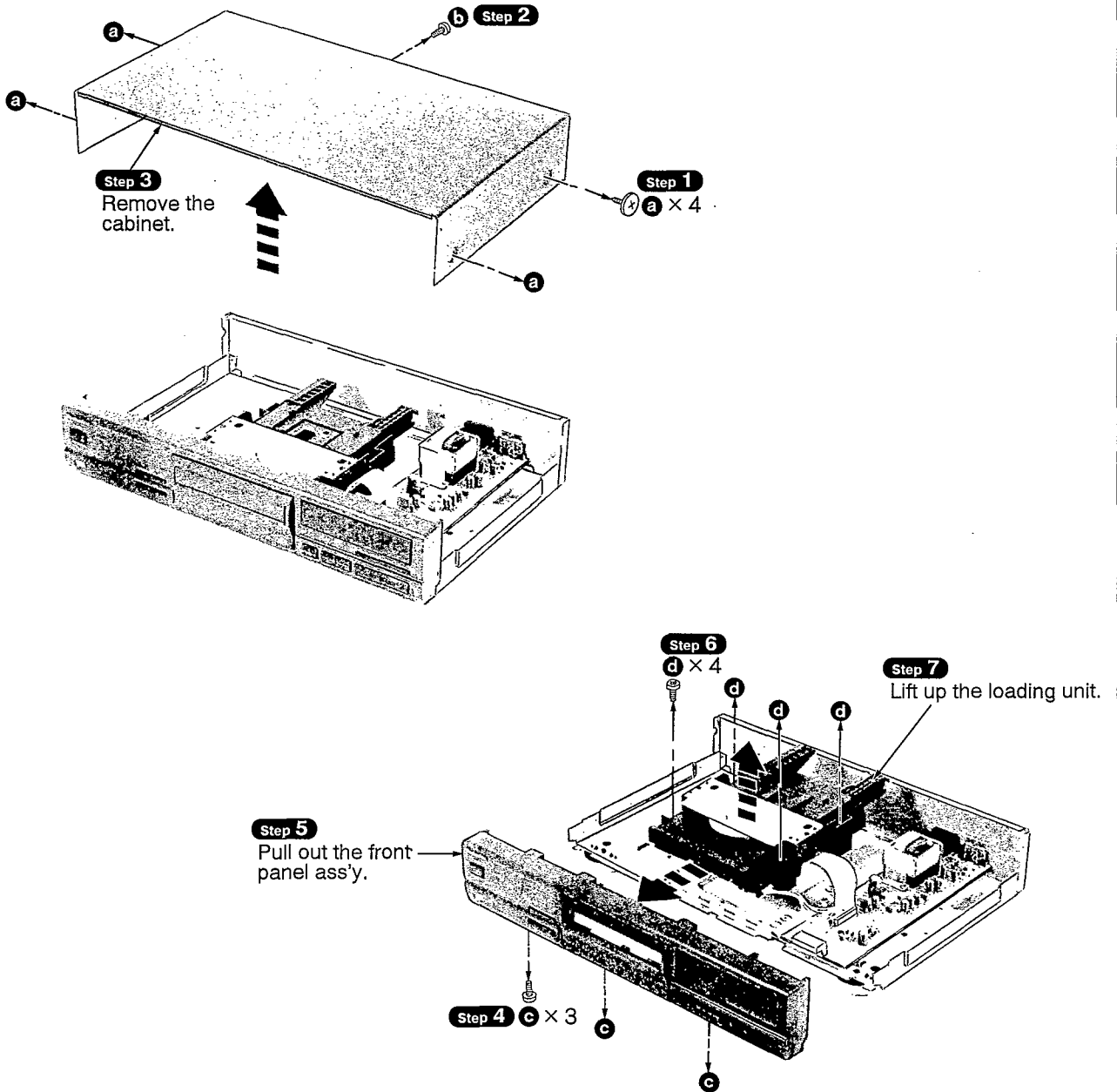

• Check the servo P.C.B. as shown below.

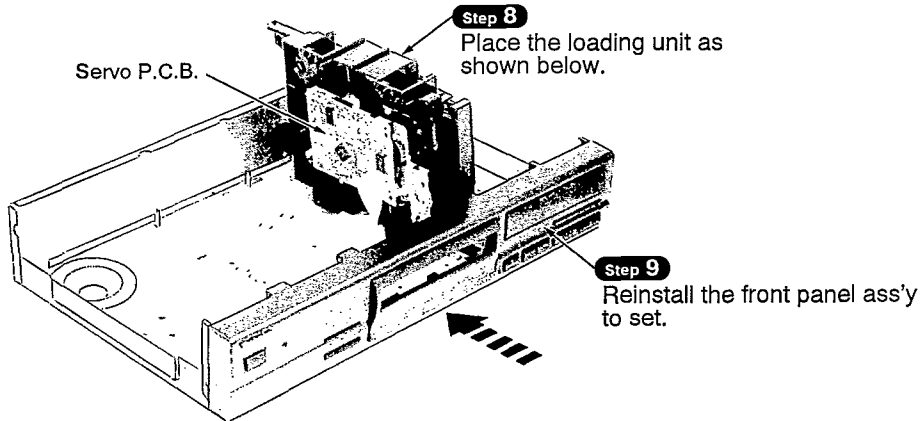

- |                       |          |
|-----------------------|----------|
|                       | <b>a</b> |
| [RHD30035-K1] (Black) |          |
|                       | <b>b</b> |
| [XTBS3+8JFZ1] (Black) |          |
|                       | <b>c</b> |
| [XTB3+10JFZ] (Black)  |          |
|                       | <b>d</b> |
| [XTB3+8JFZ] (Black)   |          |

# Main Component Replacement Procedures

## 1. Replacement for the traverse unit ass'y

• Follow the **Step 1** ~ **Step 7** of item 2 in checking procedure for each P.C.B. on page 9.

- a**  
[XTB3+8JFZ] (Black)
- b**  
[XTBS26+8J]

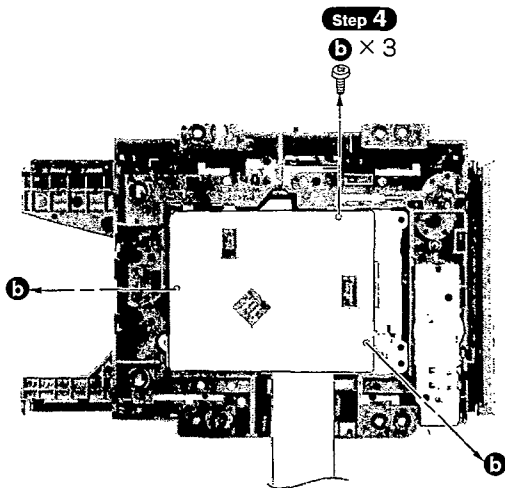
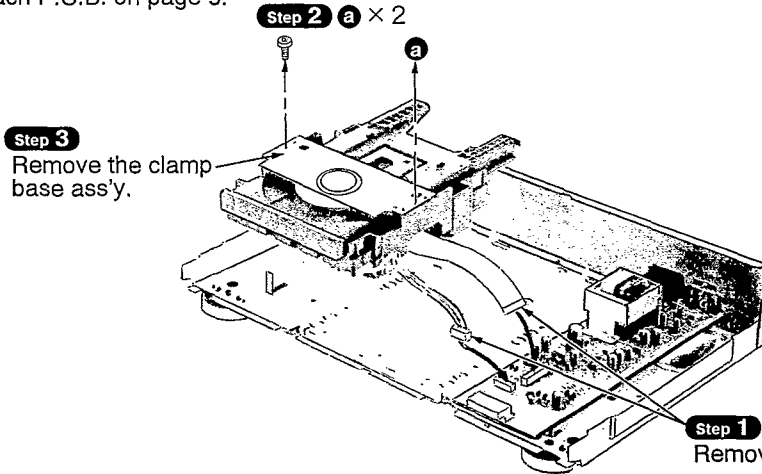

### Removal of the FFC

• Push the top of the connector in the direction of arrow ①, and then pull out the FFC in the direction of arrow ②.

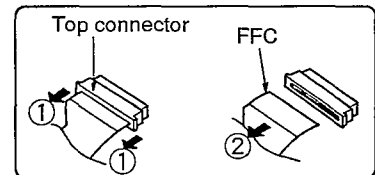

### NOTE

Insert a shorting pin into the traverse unit FFC. (Refer to Handling Precautions for Traverse Deck on page 2.)

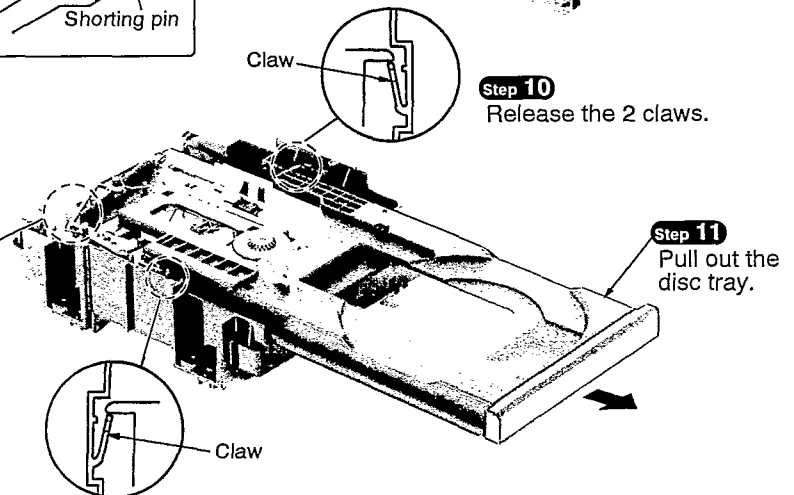
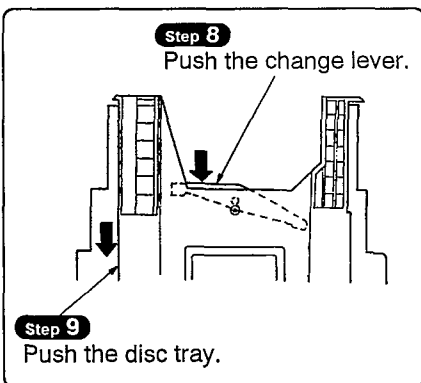
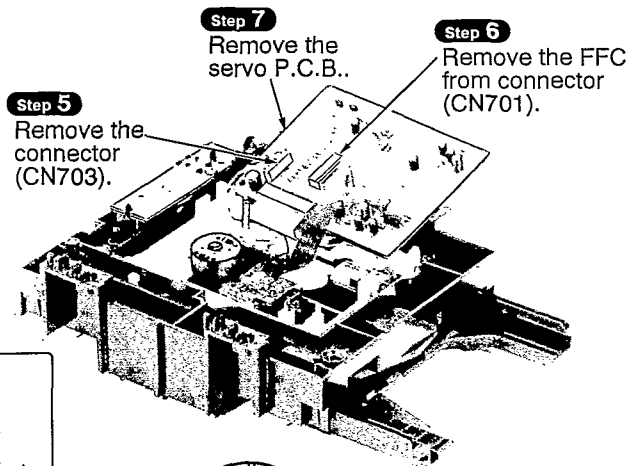
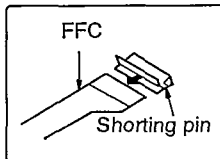

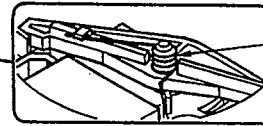
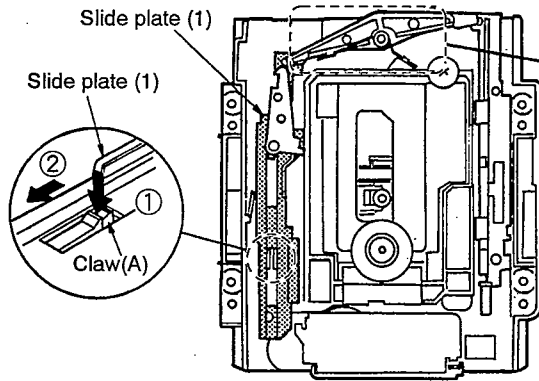

**Step 12**  
Remove the spring.

**NOTE**

Be careful not to damage the claw (A) because the claw (A) is breakable.

**Step 13**

Push the claw (A) in the direction of arrow ①, and then move the side plate (1) in the direction of arrow ②.

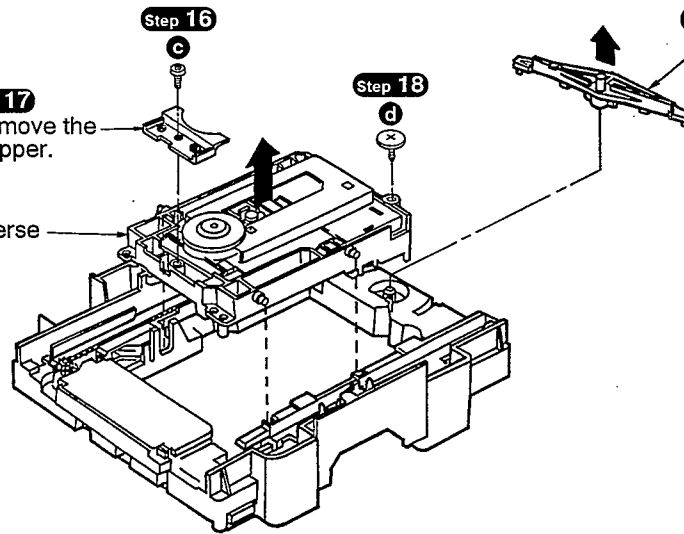

**Step 14**  
Remove the change lever.

**Step 17**  
Remove the stopper.

**Step 15**  
Remove the traverse unit ass'y.

**Step 16**

**Step 18**

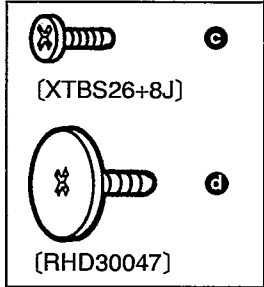

**Step 20**

Remove the damping rubber from traverse chassis.

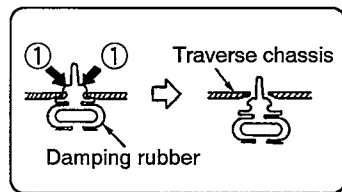

**Step 19**

Remove the lead wire from clamber.

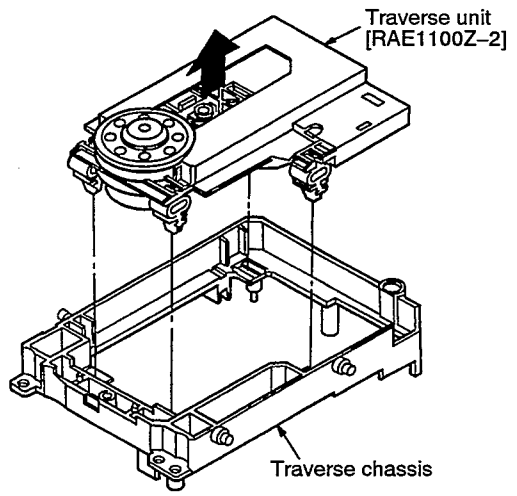
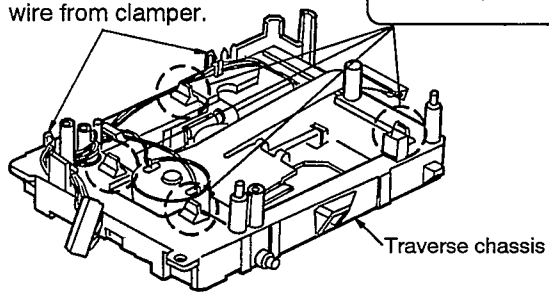

**Installation of the disc tray after replacement**

**Step 1**  
Slide the drive rack fully in the direction of arrow.

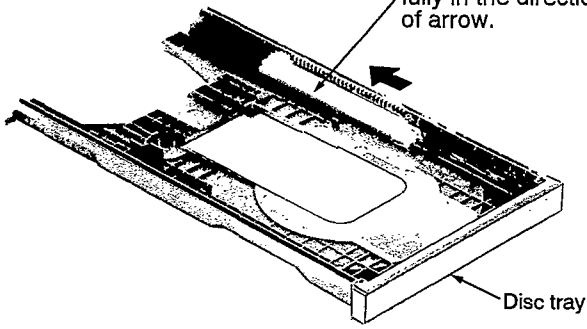

**Step 2**  
Slide the change lever, and then leave the traverse unit ass'y falling.

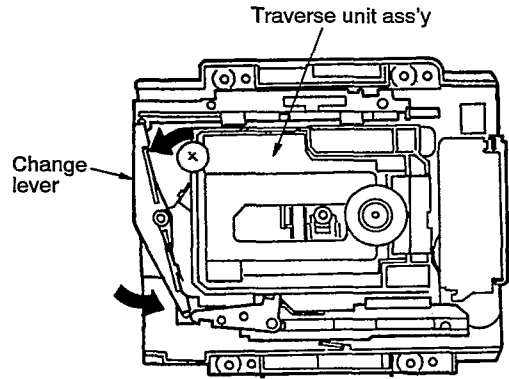

**Step 3**  
Align the disc tray groove with the mechanism chassis rib.

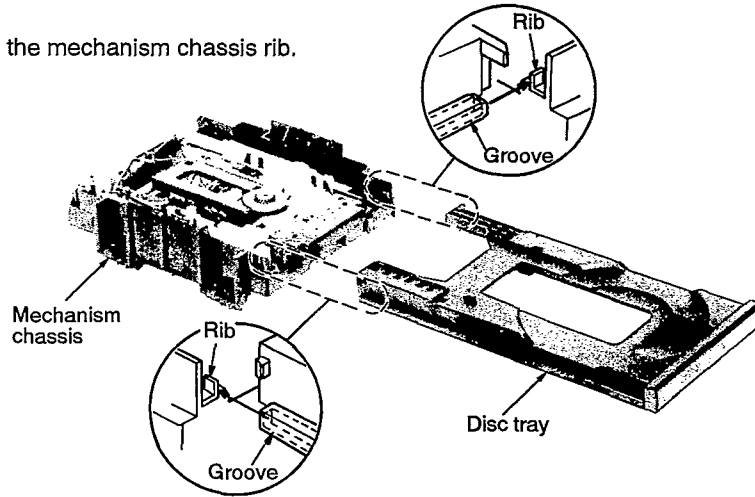

**Step 4**  
Slide the disc tray in the direction of arrow. Then, put the drive rack manually so that the drive gear (1) engages with the drive rack gear.

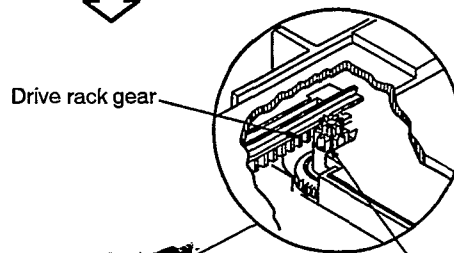

**Step 5**  
After the drive gear (1) engaged with the drive rack gear, slide the disc tray.

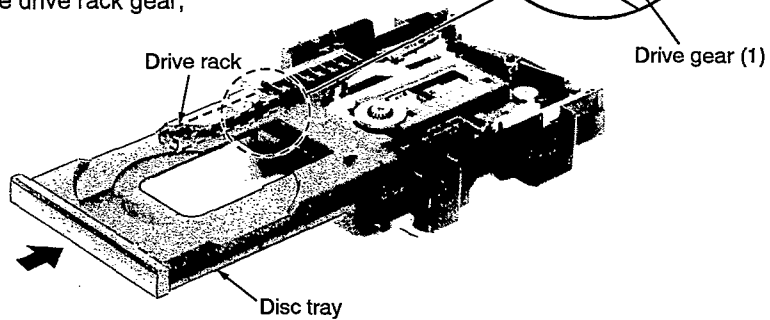

## 2. Replacement for the loading belt and loading motor

- Follow the **Step 1** ~ **Step 7** of item 2 in checking procedure for each P.C.B. on page 9.
- Follow the **Step 1** ~ **Step 11** of item 1 in main component replacement procedures on page 10.

**Step 1**  
Release the 2 claws.

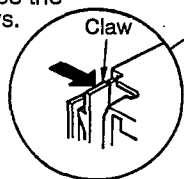

**Step 2**  
Remove the gear cover.

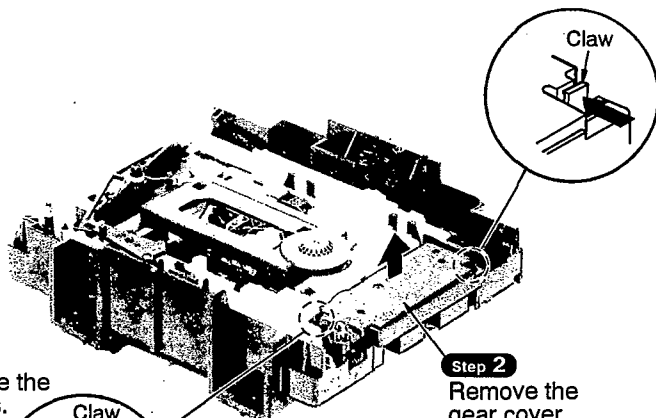

**Step 3**  
Remove the loading belt [RMG0158]

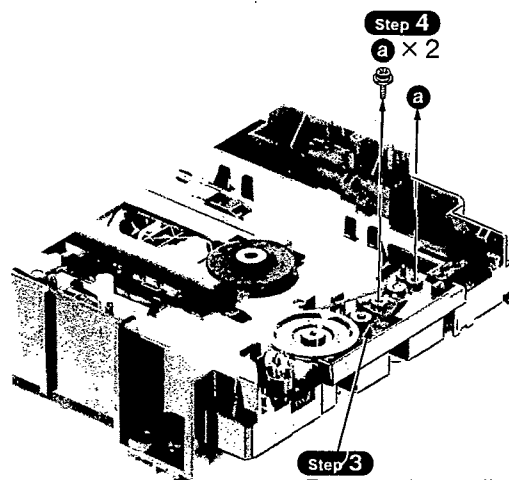

**Step 5**

**Step 6**  
Unsolder

Loading motor [REM0047]

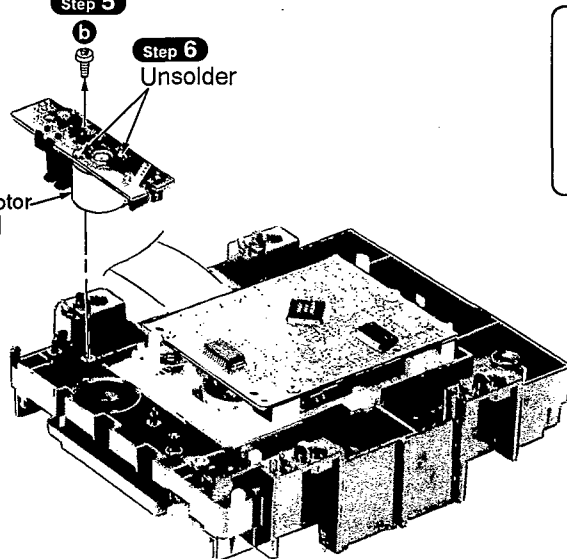

Polarity of motor ass'y terminals

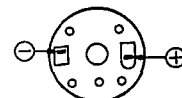

- a**  
[XYN2+F6FZ]
- b**  
[XTBS26+8J]

## Automatic Adjustment Results Display Function (Self-Check Function)

This unit has a function that uses the FL display board to indicate the results of automatic adjustment of the servo-circuit (tracking, focus, offset, etc.) as error codes. The error code display indicates the location of failures from automatic adjustment circuit.

The following procedure displays the error codes from the self-diagnostic function.

### Procedure for displaying automatic adjustment codes

1. Plug in the power cord and wait for the STANDBY LED to flash, indicating the unit is in standby status.
2. Turn on the power supply switch while pressing the STOP (■), PAUSE (▨) and PLAY (▶) buttons at the same time.
3. The "F E C" code is displayed 2 or 3 seconds later to indicate the automatic adjustment results mode.
4. Push the OPEN/CLOSE button to open the disc tray and then load the test disc (SZZP1054C).
5. Push the OPEN/CLOSE button again to close the disc tray.
6. After automatic adjustment, the code display indicates the location of failures in the servo circuit.

### Troubleshooting using the automatic adjustment code

#### Notes:

1. If "E-00" or "E-20" is displayed as an error code, this means no error was found.
2. Check the disc and laser-detector lens for damage, contamination or stains.

• Take out the test disc and turn off the power, which terminates the automatic adjustment results mode.

FL error code display	Symptom	Probable cause	Signal to check		Normal voltage and waveform values	
			Location	Signal name	PLAY	STOP
E-01	Focus and tracking offset adjustments not completed in specified time period.	① Clocks X1 and X2, power supply VDD, and reset (/RST), all on IC702. ② MDATA, MCLK, MLD, and SENSE signals to/from mechanism controller.	IC702 ⑧ pin	MDATA		5.0 V
			IC702 ⑦ pin	MCLK		5.0 V
			IC702 ⑨ pin	MLD	0 V	0 V
			IC702 ⑩ pin	SENSE	0 V	0 V
			IC702 ⑱ pin	/RST	5.0 V	5.0 V
			IC702 ⑤⑧ pin	X1		
IC702 ⑤⑨ pin	X2					
E-03 E-05 E-07 E-09 E-0B E-0D E-0F	Disc play unstable	① Scratches or contaminants on disc surface ② Focus and Tracking servo circuits (check waveforms, voltages, and part values.) ③ Spindle driver circuit ④ Optical pickup	IC702 ③② pin	F E		2.6 V
IC702 ③③ pin			T E		2.5 V	
IC702 ②⑧ pin			FOD	2.5 V	2.5 V	
IC702 ②⑦ pin			TRD	2.5 V	2.5 V	
IC702 ②⑥ pin			KICK	2.5 V	2.5 V	
IC702 ①① pin			/FLOCK	0 V	5.0 V	
IC702 ③⑧ pin			/RF DET	0 V	4.9 V	
TJ701			R F		2.5 V	
IC702 ①⑦ pin			STAT	3.3 V	0 V	
E-04 E-06 E-0C E-0E	Best "eye" (PD balance) adjustment not completed in specified time period.	① Scratches or contaminants on disc surface ② Focus servo circuit (check waveforms, voltages, and part values.) ③ Optical pickup	IC702 ③① pin	FBAL	2.5 V ± 1.25 V	2.5 V ± 1.25 V
TJ701			R F		2.5 V	
IC702 ③② pin			F E		2.6 V	
IC702 ③⑥ pin			O F T	0 V	0 V	
IC702 ①② pin			/TLOCK	0 V	0 V	
E-08 E-0A			Focus or Tracking gain adjustment not completed in specified time period.	① Scratches or contaminants on disc surface ② Focus and Tracking servo circuit (check waveforms, voltages, and part values.) ③ Optical pickup	IC702 ③② pin	F E
IC702 ③③ pin	T E				2.5 V	
IC702 ③⑥ pin	O F T	0 V			0 V	
IC702 ①② pin	/TLOCK	0 V			0 V	

## ■ Schematic Diagram

	Page
<b>A</b> SERVO CIRCUIT .....	16, 17
<b>B</b> POWER SWITCH CIRCUIT .....	18
<b>C</b> OPERATION CIRCUIT .....	18
<b>D</b> LOADING MOTOR CIRCUIT .....	19
<b>E</b> MAIN CIRCUIT .....	18, 19

- This schematic diagram may be modified at any time with the development of new technology.

### Notes:

- S601 : Time mode select switch (TIME MODE)
- S602 : Auto cue switch (AUTO CUE)
- S604 : Peak level search switch (PEAK SEARCH)
- S605 : Random play switch (RANDOM)
- S621 : F. Skip switch (▶▶/▶▶)
- S622 : Pause switch (||)
- S623 : Disc tray open/close switch (▲ OPEN/CLOSE)
- S624 : Program switch (PROGRAM)
- S625 : Repeat switch (REPEAT)
- S626 : Stop switch (■)
- S627 : Play switch (▶)
- S628 : R. Skip switch (◀◀/◀◀)
- S629 : Clear switch (CLEAR)
- S630 : Recall switch (RECALL)
- S651 : Power "STANDBY ⏻ /ON" switch (POWER)
- S701 : Rest switch
- S781 : Tray open detect switch
- S782 : Tray close detect switch

- Indicated voltage values are the standard values for the unit measured by the DC electronic circuit tester (high-impedance) with the chassis taken as standard. Therefore, there may exist some errors in the voltage values, depending on the internal impedance of the DC circuit tester.

No mark : CD STOP  
 ( ) : CD PLAY [1 kHz, L + R, 0 dB]

- Important safety notice:

Components identified by  mark have special characteristics important for safety.

Furthermore, special parts which have purposes of fire-retardant (resistors), high-quality sound (capacitors), low-noise (resistors), etc. are used. When replacing any of components, be sure to use only manufacturer's specified parts shown in the parts list.

- **Caution!**

IC and LSI are sensitive to static electricity.

Secondary trouble can be prevented by taking care during repair.

Cover the parts boxes made of plastics with aluminum foil.

Ground the soldering iron.

Put a conductive mat on the work table.

Do not touch the legs of IC or LSI with the fingers directly.

- **Voltage and signal line**

 : Positive voltage line

 : Negative voltage line

 : CD signal Line

**A SERVO CIRCUIT (P.C. Board : on page 20)**

**OPTICAL PICKUP**

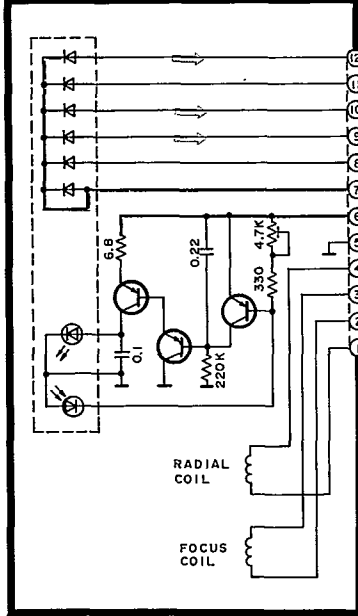

SLEDGE MOTOR

SPINDLE MOTOR

S701 (REST)

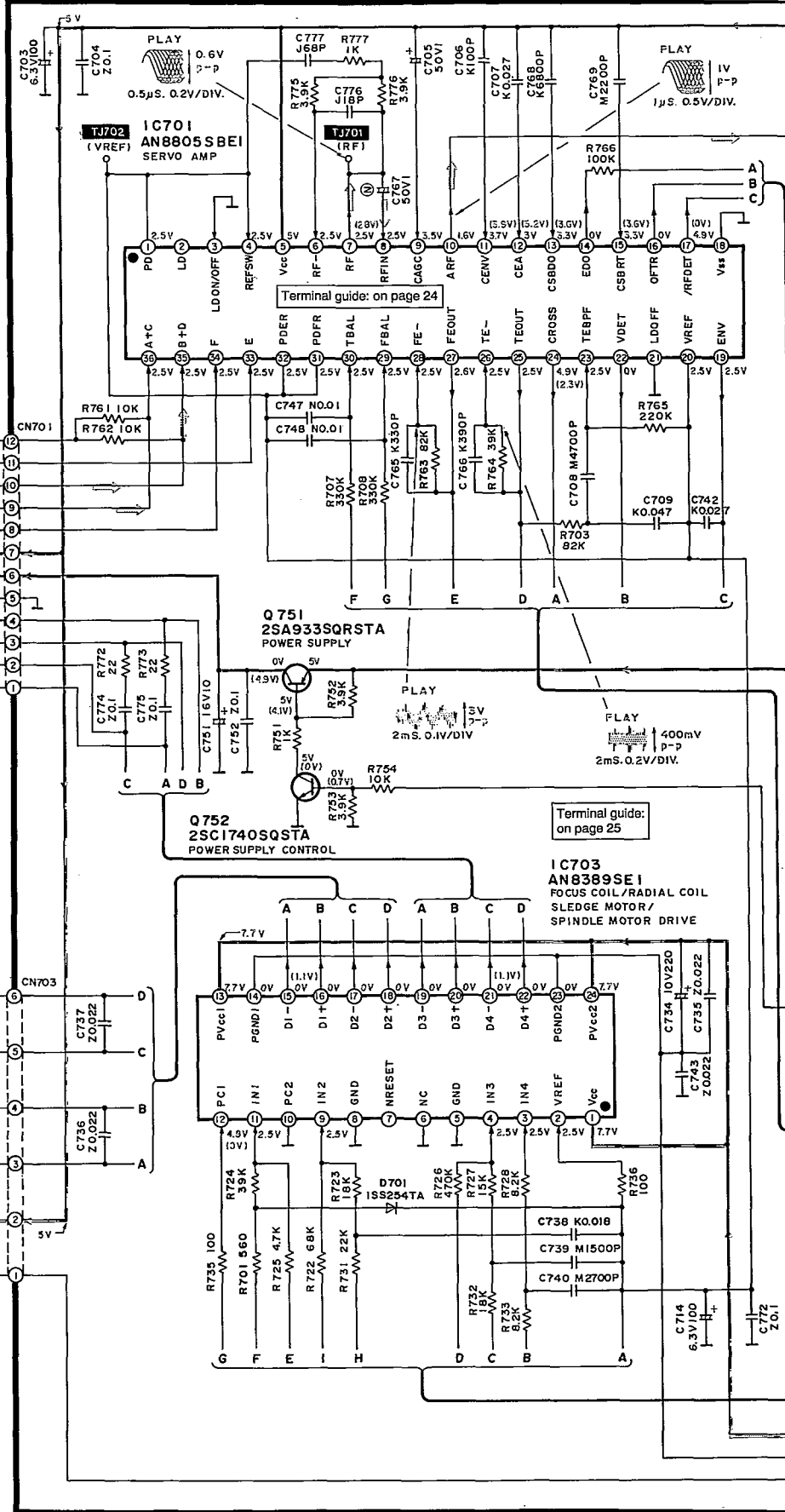

Terminal guide: on page 25



→ : Positive voltage line      ←←← : Negative voltage line      → : CD signal Line

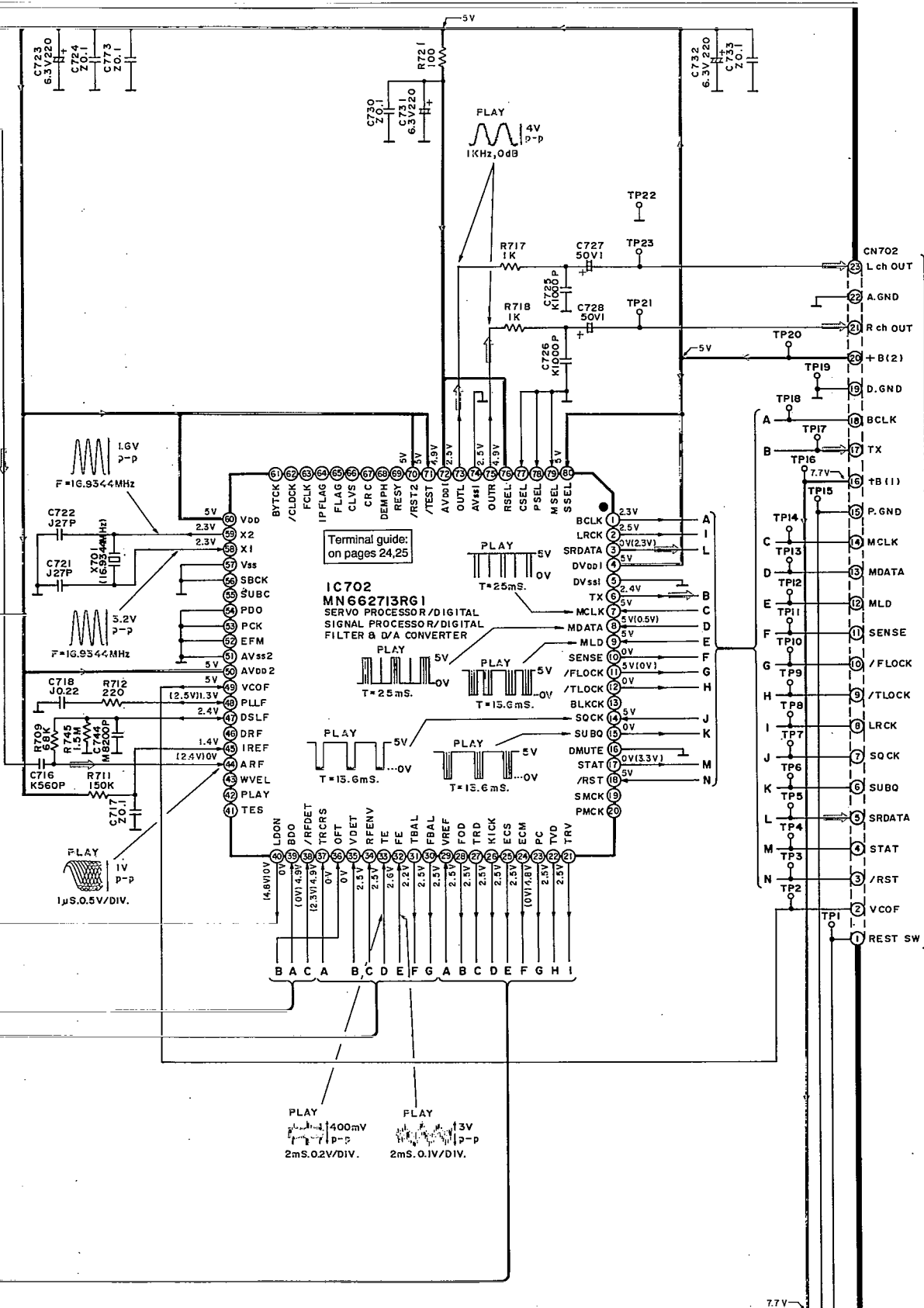

**B** POWER SWITCH CIRCUIT  
(P.C.Board: on page 20)

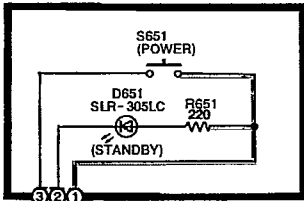

- : Positive voltage line
- : Negative voltage line
- : CD signal Line

**C** OPERATION CIRCUIT (P.C.Board: on page 21)

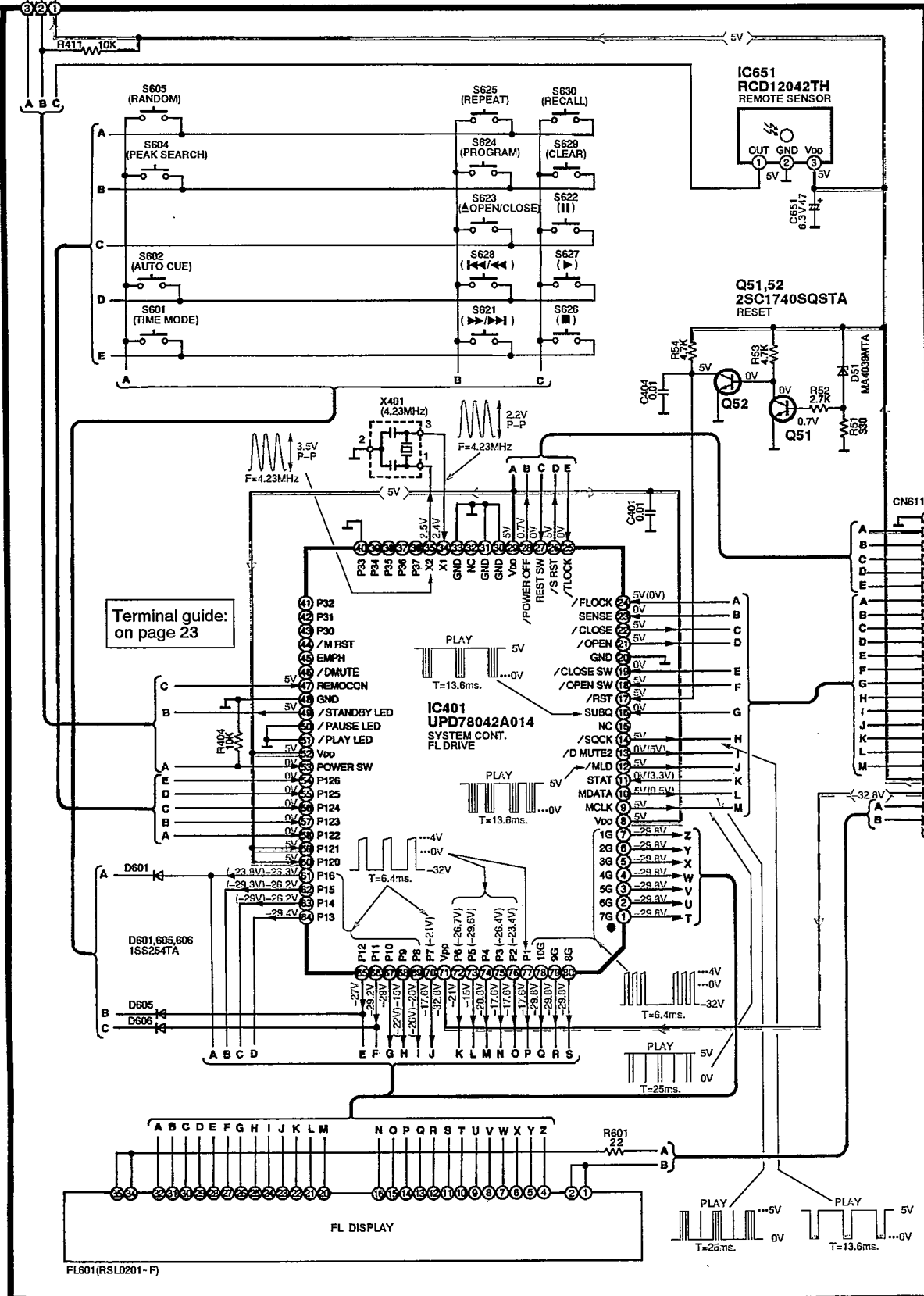

**D** LOADING MOTOR CIRCUIT  
(P.C. Board: on page 20)

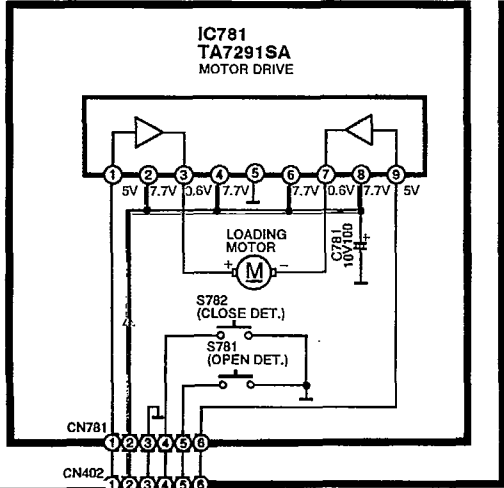

**E** MAIN CIRCUIT (P.C. Board: on page 21)

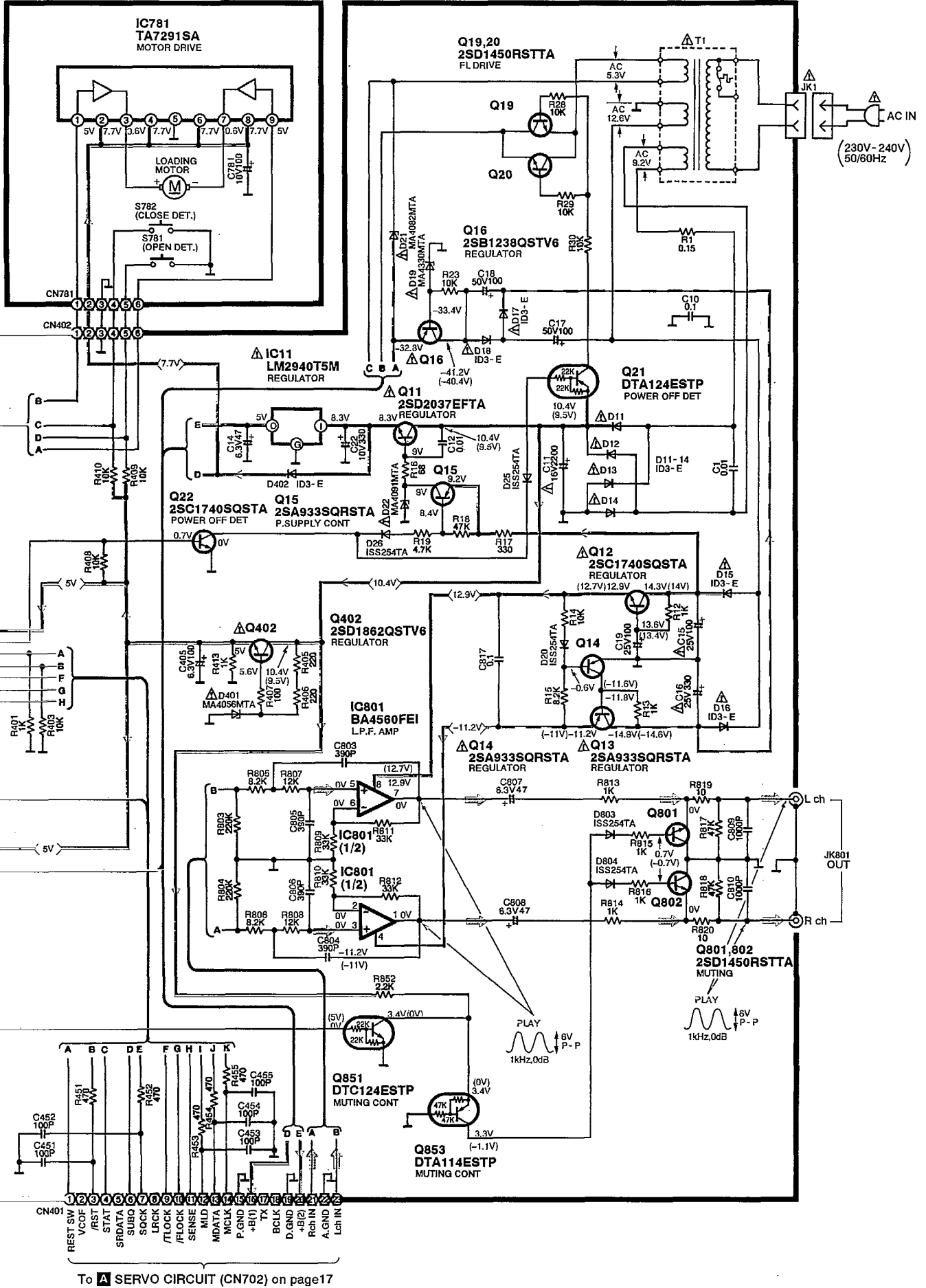

To **A** SERVO CIRCUIT (CN702) on page 17

# Printed Circuit Board Diagram

• This circuit board diagram may be modified at any time with the development of new technology.

## A SERVO P.C.B.(REP1755A-N)

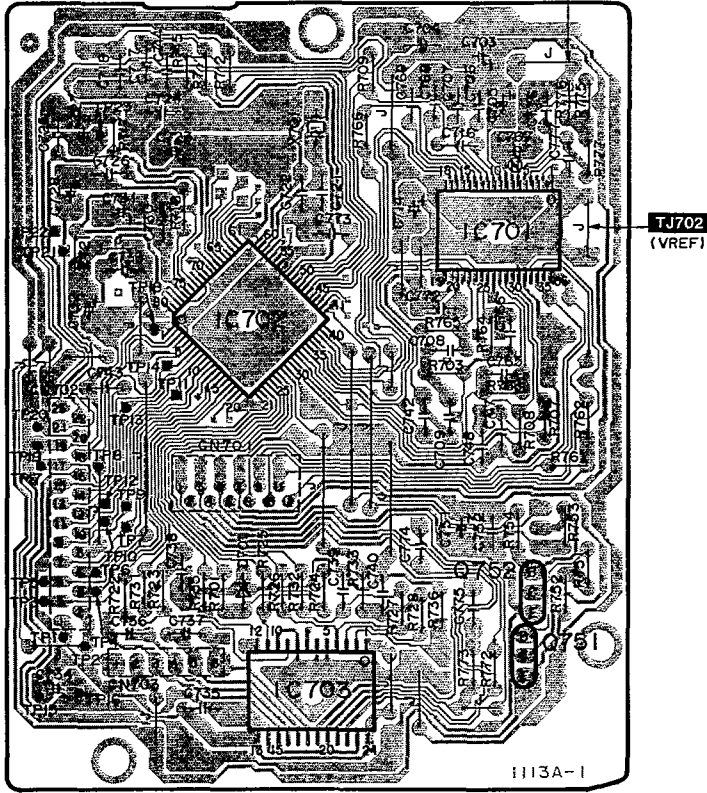

## B POWER SWITCH P.C.B. (REP2356A-S)

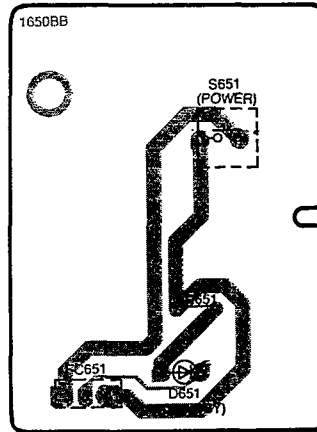

## D LOADING MOTOR P.C.B.(REP1940A-N)

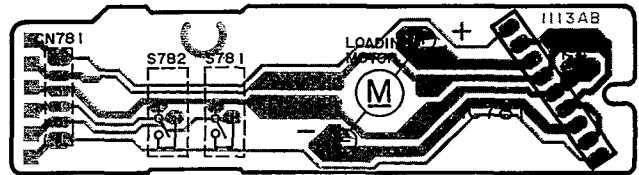

<p>BA4560FE1</p>	<p>AN8805SBE1</p>	<p>AN8389SE1</p>	<p>TA7291SA</p>	<p>LM2940T5</p> <p>I:IN G:GND O:OUT</p>	<p>UPD78042A014</p>
<p>MN662713RG1</p>	<p>RCD12042TH</p>	<p>2SA933SQ 2SC1740SQ DTA114ESTP DTA124ESTP DTC124EST</p>		<p>2SD2037EFTA</p>	<p>2SB1238QSTV6</p>
<p>2SD1450RTA</p>	<p>2SD1862QSTV6</p>	<p>MA4039MTA MA4056MTA MA4082MTA MA4091-M</p>		<p>1D3-E</p>	<p>MA4330MTA</p>
<p>1SS254TA</p>	<p>SLR-305LC</p>				

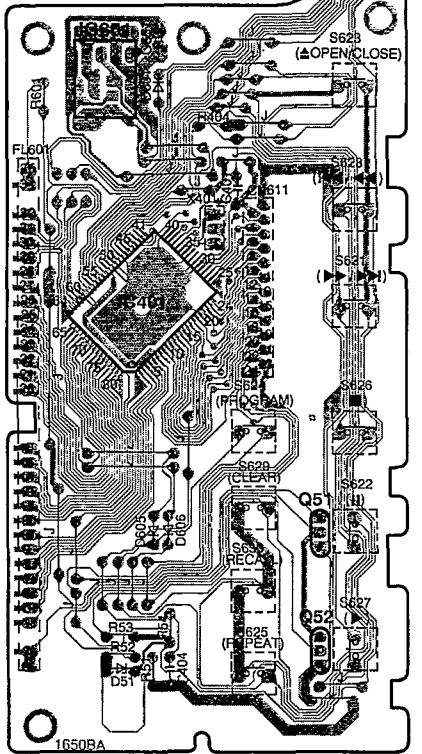
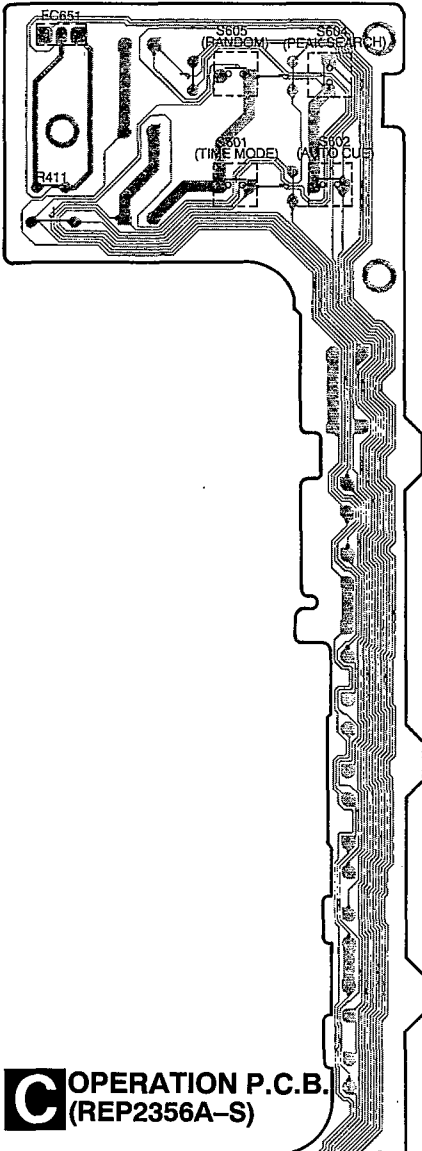

**E** MAIN P.C.B. (REP2354B-1M)

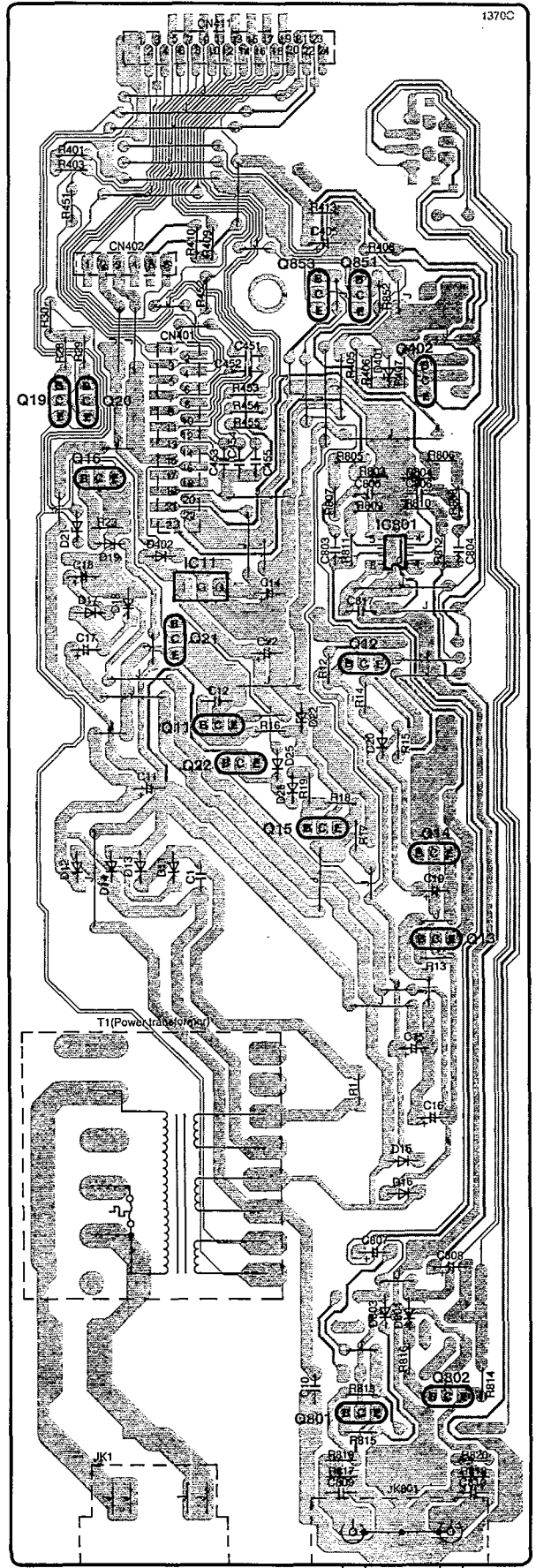

# ■ Wiring Connection Diagram

**NOTE:**

- BLK ..... Black
- BLU ..... Blue
- BRN ..... Brown
- ORG ..... Orange
- WHT ..... White
- YEL ..... Yellow

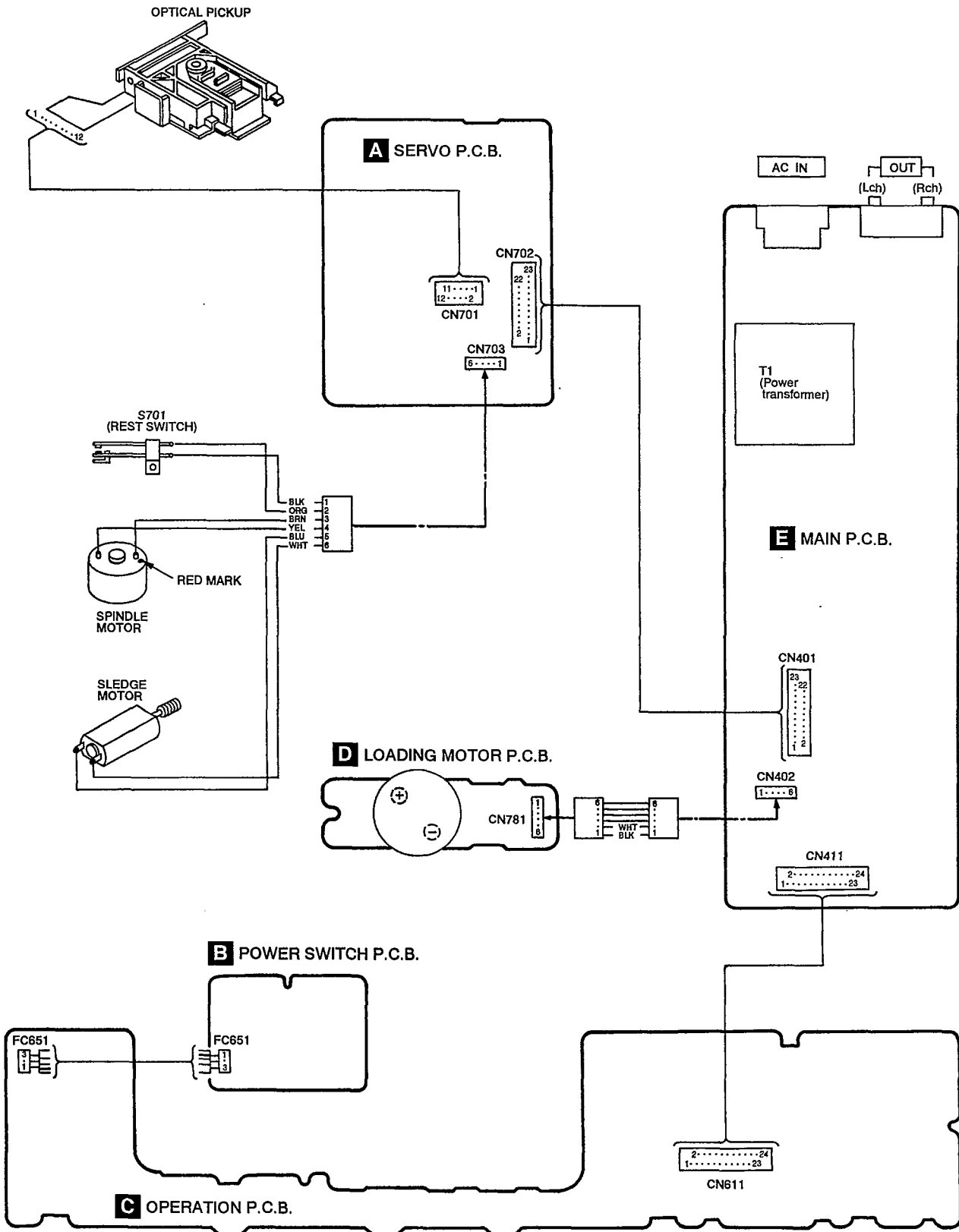

## ■ Function of IC Terminals

### ● IC401 (UPD78042A014)

Pin No.	Terminal Name	I/O	Function
1 ~ 7	7G1G	O	FL grid drive signal output
8	VDD	—	Power supply (+ 5 V)
9	MCLK	O	Microprocessor command clock
10	MDATA	O	Microprocessor command data
11	STAT	I	Status signal input
12	/MLD	O	Microprocessor command load signal
13	/DMUTE2	O	No used, open
14	SQCK	O	External clock for sub-code Q register
15	NC	—	No used, open
16	SUBQ	I	Sub-code Q input
17	/RST	I	Reset signal input
18	/OPEN SW	I	Disc tray "open" sense switch status
19	/CLOSE SW	I	Disc tray "close" sense switch status
20	GND	—	Connect to GND
21	/OPEN	O	Open Disc Tray command output
22	/CLOSE	O	Close Disc Tray command output
23	SENSE	I	Sense signal input
24	/FLOCK	I	Focus servo pull-in signal
25	/TLOCK	I	Tracking servo pull-in signal
26	/S RST	O	Reset signal output (for servo)
27	REST SW	I	Innermost track sense switch status
28	/POWEROFF	O	Power off command output
29	VDD	—	Power supply (+ 5 V)
30	GND	—	Connect to GND
31	GND	—	Connect to GND
32	NC	—	No used, open
33	GND	—	Connect to GND
34	X1	I	Main clock (4.23 MHz) input
35	X2	O	Main clock output
36 ~ 39	P37 ~ P34	I	No used, open
40	P33	I	Connect to GND
41 ~ 43	P32 ~ P30	I	No used, open

Pin No.	Terminal Name	I/O	Function
44	/MRST	O	Reset signal output for MASH (IC801)
45	EMPH	O	Emphasis signal output
46	/DMUTE	O	Muting signal output
47	REMOCON	I	Remote control signal input
48	GND	—	Connect to GND
49	/STANDBY LED	O	STANDBY LED control signal output
50	/PAUSE LED	O	PAUSE LED control signal output
51	/PLAY LED	O	PLAY LED control signal output
52	VDD	—	Power supply (+ 5 V)
53	POWER SW	I	Power key switch signal input
54 ~ 58	P126 ~ P122	I	Key return signal input
59, 60	P121 ~ P120	—	Connect to GND
61 ~ 66	P16 ~ P11	O	FL anode drive signal and key scan signal output
67 ~ 70	P10 ~ P7	O	FL anode drive signal output
71	VPP	—	Power supply terminal for FL drive (– 32 V)
72 ~ 77	P6 ~ P1	O	FL anode drive signal output
78 ~ 80	10G ~ 8G	O	FL grid drive signal output

## ● IC701 (AN8805SBE1)

Pin No.	Terminal Name	I/O	Function
1	PD	I	APC amplifier input
2	LD	O	APC amplifier output (No used, open)
3	LD ON/OFF	I	APC ON/OFF control signal
4	REFSW	I	Capacitor connection for CROSS
5	VCC	—	Power supply
6	RF-	I	RF amplifier inversion signal input
7	RF	O	RF amplifier signal output
8	RFIN	I	AGC signal input
9	CAGC	I	AGC loop filter connection
10	ARF	O	AGC signal output
11	CENV	I	Capacitor connection for RF detection
12	CEA	I	Capacitor connection for HPF amplifier
13	CSBDO	I	Capacitor connection for RF envelope detection
14	EDO	O	BDO signal output
15	CSBRT	I	Capacitor connection for RF envelope detection
16	OFTR	O	OFTR signal output
17	/RFDET	O	RFDET signal output
18	Vss	—	GND
19	ENV	O	3TENV signal output
20	VREF	O	VREF signal output
21	LD OFF	—	APC OFF signal control
22	VDET	O	VDET signal output'
23	TEBPF	I	VDET signal input
24	CROSS	O	CROSS signal output
25	TEOUT	O	TE amplifier signal output
26	TE-	I	TE amplifier inversion signal input
27	FEOUT	O	FE amplifier signal output
28	FE-	I	FE amplifier inversion signal input
29	FBAL	I	F BAL control signal
30	TBAL	I	T BAL control signal
31	PDFR	—	Adjustment for I-V amplifier conversion resistor
32	PDER	—	Adjustment for I-V amplifier conversion resistor
33	E	I	I-V amplifier signal input
34	F	I	I-V amplifier signal input
35	B+D	I	I-V amplifier signal input
36	A+C	I	I-V amplifier signal input

## ● IC702 (MN662713RG1)

Pin No.	Terminal Name	I/O	Function
1	BCLK	O	Bit clock output for serial data
2	LRCK	—	L/R identification signal output
3	SRDATA	—	Serial data output
4	DVDD1	—	Power supply input (for digital circuit)
5	DVSS1	—	GND (for digital circuit)
6	TX	O	Digital audio interface signal output
7	MCLK	I	Microprocessor command clock signal input (Latches data at first transition)
8	MDATA	I	Microprocessor command data signal input
9	MLD	I	Microprocessor command load signal input
10	SENSE	O	Sense signal output (OFT, FESL, MAGEND, NAJEND, POSAD, SFG)
11	/FLOCK	O	Focus servo feeding signal output ("L": Feed)
12	/TLOCK	O	Tracking servo feeding signal output ("L": Feed)
13	BLKCK	O	Sub-code block clock signal output (fBLKCK = 75 Hz during normal playback) (no used, open)
14	SQCK	I	External clock signal input for sub-code Q resistor
15	SUBQ	O	Sub-code Q code output
16	DMUTE	I	Muting input ("H": Mute)
17	STAT	O	Status signal output (CRC, CUE, CLVS, TTSTVP, FCLV, SQCK)
18	/RST	I	Reset input
19	SMCK	—	1/2-divided clock signal of crystal oscillating at MSEL = "H" (fSMCK = 8.4672 MHz) 1/4-divided clock signal of crystal oscillating at MSEL = "L" (fSMCK = 4.2336 MHz) (no used, open)
20	PMCK	—	1/192-divided clock signal of crystal oscillating (fPMCK = 88.2 kHz) (no used, open)
21	TRV	O	Traverse forced feed output
22	TVD	O	Traverse drive output
23	PC	O	Spindle motor ON signal output ("L": ON)
24	ECM	O	Spindle motor drive signal output (forced mode output)
25	ECS	O	Spindle motor drive signal output (servo error signal output)
26	KICK	O	Kick pulse output
27	TRD	O	Tracking drive output
28	FOD	O	Focus drive output
29	VREF	I	D/A (drive) output (TVD, ECS, TRD, FOD, FBAL, TBAL) reference voltage input
30	FBAL	O	Focus balance adjustment output
31	TBAL	O	Tracking balance adjustment output
32	FE	I	Focus error signal input (analog input)
33	TE	I	Tracking error signal input (analog input)
34	RFENV	I	RF envelope signal input
35	VDET	I	Vibration detection signal input ("H": detection)
36	OFT	I	Off-track signal input ("H": off track)



## IC702 Continued

Pin No.	Terminal Name	I/O	Function
37	TRCRS	I	Track cross signal input
38	/RFDET	I	RF detection signal input ("L": detection)
39	BDO	I	Dropout signal input ("H": Dropout)
40	LDON	O	Laser on signal output ("H": ON)
41	TES	O	Tracking error shunt signal output ("H": shunt) (no used, open)
42	PLAY	O	Play signal out ("H": PLAY) (no used, open)
43	WVEL	O	Double speed status signal output ("H": Double speed) (no used, open)
44	ARF	I	RF signal input
45	IREF	I	Reference current input
46	DRF	—	DSL bias (no used, open)
47	DSLIF	I/O	DSL loop filter
48	PLLF	I/O	PLL loop filter
49	VCOF	I/O	VCO loop filter
50	AVdd2	—	Power supply input (for analog circuit)
51	AVss2	—	GND (for analog circuit)
52	EFM	—	EFM signal output (no used, open)
53	PCK	—	PLL extraction clock output (fPCK = 4.321 MHz during normal playback) (no used, open)
54	PDO	—	Phase comparison signal of EFM and PCK signals (no used, open)
55	SUBC	O	Sub-code serial data output (no used, open)
56	SBCK	I	Clock input for sub-code serial data
57	Vss	—	GND
58	X1	I	Crystal oscillating circuit input (f = 16.9344 MHz)
59	X2	O	Crystal oscillating circuit output (f = 16.9344 MHz)
60	VDD	—	Power supply input (for oscillating circuit)
61	BYTCK	—	Byte clock output (no used, open)
62	/CLDCK	O	Sub-code frame clock signal output (fCLDCK = 7.35 kHz during normal playback)
63	FCLK	—	Crystal frame clock signal output (fFCLK = 7.35 kHz, double = 14.7 kHz)
64	IPFLAG	O	Interpolation flag output ("H": Interpolation) (no used, open)
65	FLAG	O	Flag output (no used, open)
66	CLVS	O	Spindle servo phase synchronizing signal output ("H": CLV, "L": rough servo) (no used, open)
67	CRC	O	Sub-code CRC checked output ("H": OK, "L": NG) (no used, open)
68	DEMPH	O	De-emphasis ON signal output ("H": ON) (no used, open)
69	RESY	—	Frame resynchronizing signal output (no used, open)
70	/RST2	I	Reset input through MASH circuit ("L": Reset)
71	/TEST	I	Test input
72	AVdd1	—	Power supply input (for analog circuit)

Pin No.	Terminal Name	I/O	Function
73	OUTL	O	Left channel audio signal output
74	AVss1	—	GND
75	OUTR	O	Right channel audio signal output
76	RSEL	I	RF signal polarity assignment input (at "H" level: RSEL = "H") (at "L" level: RSEL = "L")
77	CSEL	I	Crystal oscillating frequency designation input ("L": 16.9344 MHz, "H": 33.8688 MHz)
78	PSEL	I	Test input (normally, "L")
79	MSEL	I	Output frequency switching for SMCK terminal "H": SMCK = 8.4672 MHz "L": SMCK = 4.2336 MHz
80	SSEL	I	Output mode switching of SUBQ terminal ("H": Q code buffer mode)

## ● IC703 (AN8389SE1)

Pin No.	Terminal Name	I/O	Function
1	Vcc	—	Power supply
2	VREF	I	VREF input
3	IN4	I	Motor driver (4) input
4	IN3	I	Motor driver (3) input
5	GND	—	Ground connection
6	NC	—	Ground connection
7	NRESET	—	Reset input (no used, open)
8	GND	—	Ground connection
9	IN2	I	Traverse motor driver (2) input
10	PC2	I	PC2 (power cut) input
11	IN1	I	Spindle motor driver (1) input
12	PC1	I	PC1 (power cut) input
13	PVcc1	—	Power supply (1) for driver
14	PGND1	—	Ground connection (1) for driver
15	D1-	O	Spindle motor driver (1) reverse-action output
16	D1+	O	Spindle motor driver (1) forward-action output
17	D2-	O	Traverse motor driver (2) reverse-action output
18	D2+	O	Traverse motor driver (2) forward-action output
19	D3-	O	Tracking actuator (3) reverse-action output
20	D3+	O	Tracking actuator (3) forward-action output
21	D4-	O	Focus actuator (4) reverse-action output
22	D4+	O	Focus actuator (4) forward-action output
23	PGND2	—	Ground connection (2) for driver
24	PVcc2	—	Power supply (2) for driver

# Block Diagram

Note: AUDIO SIGNAL

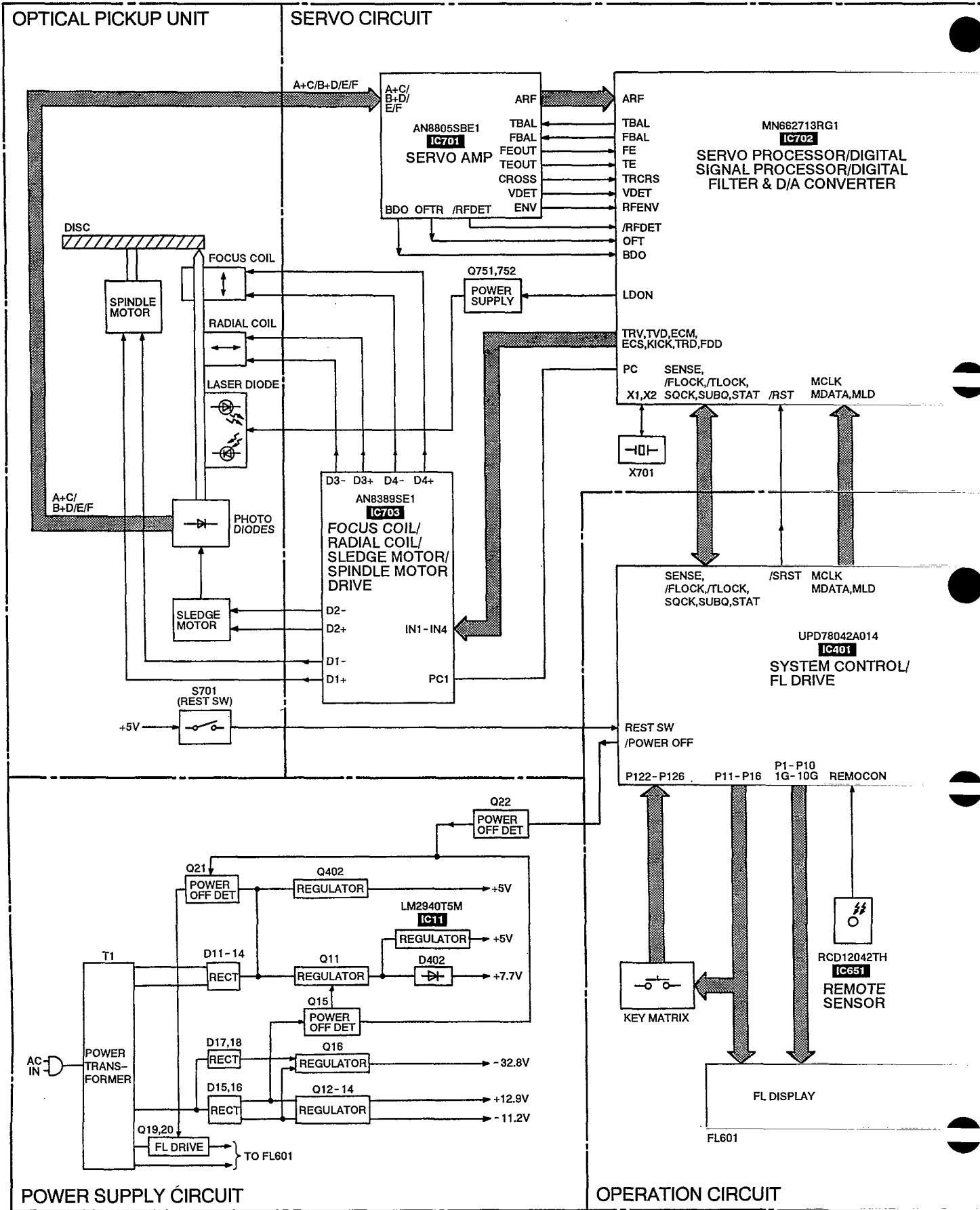

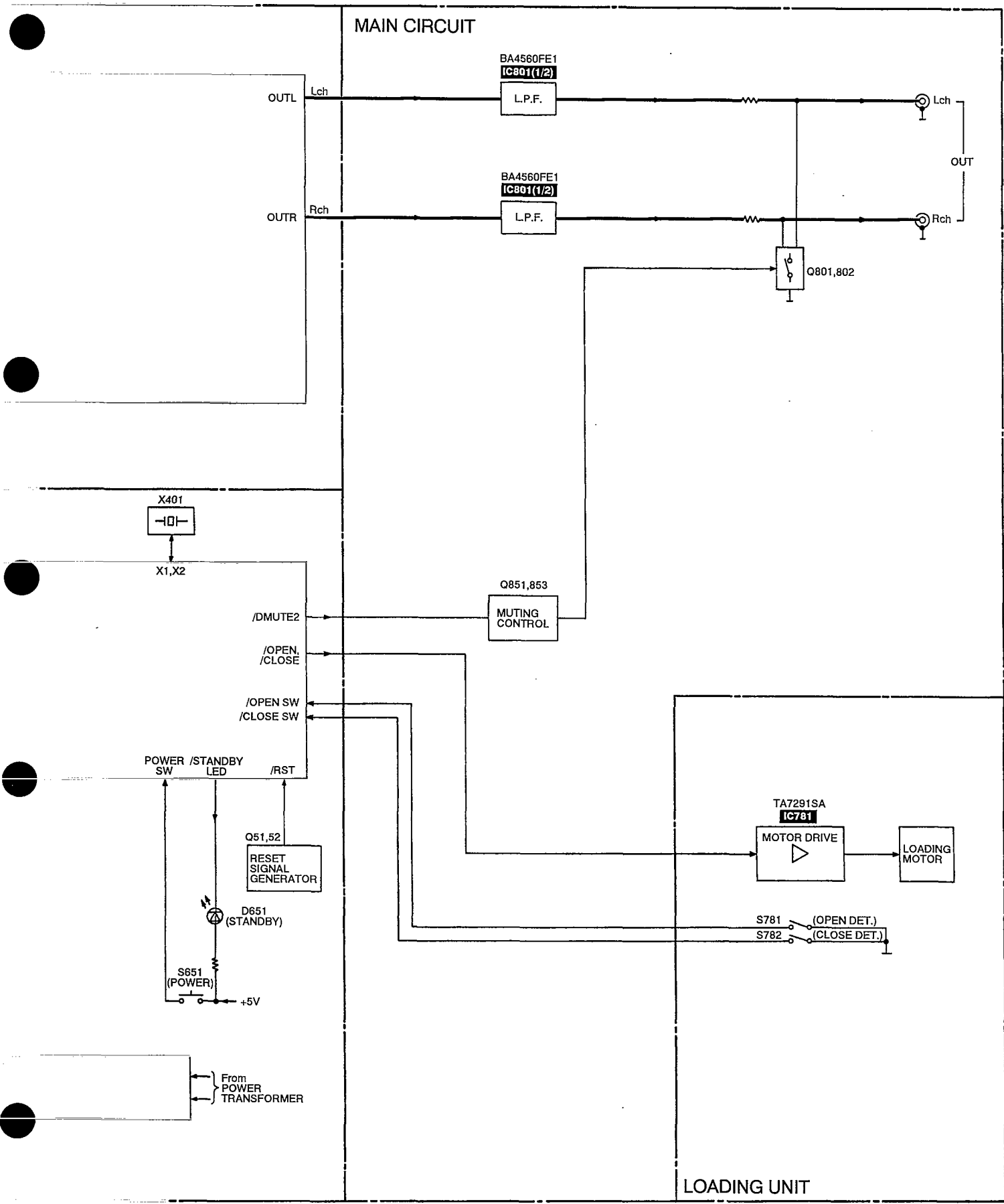

# Troubleshooting Guide

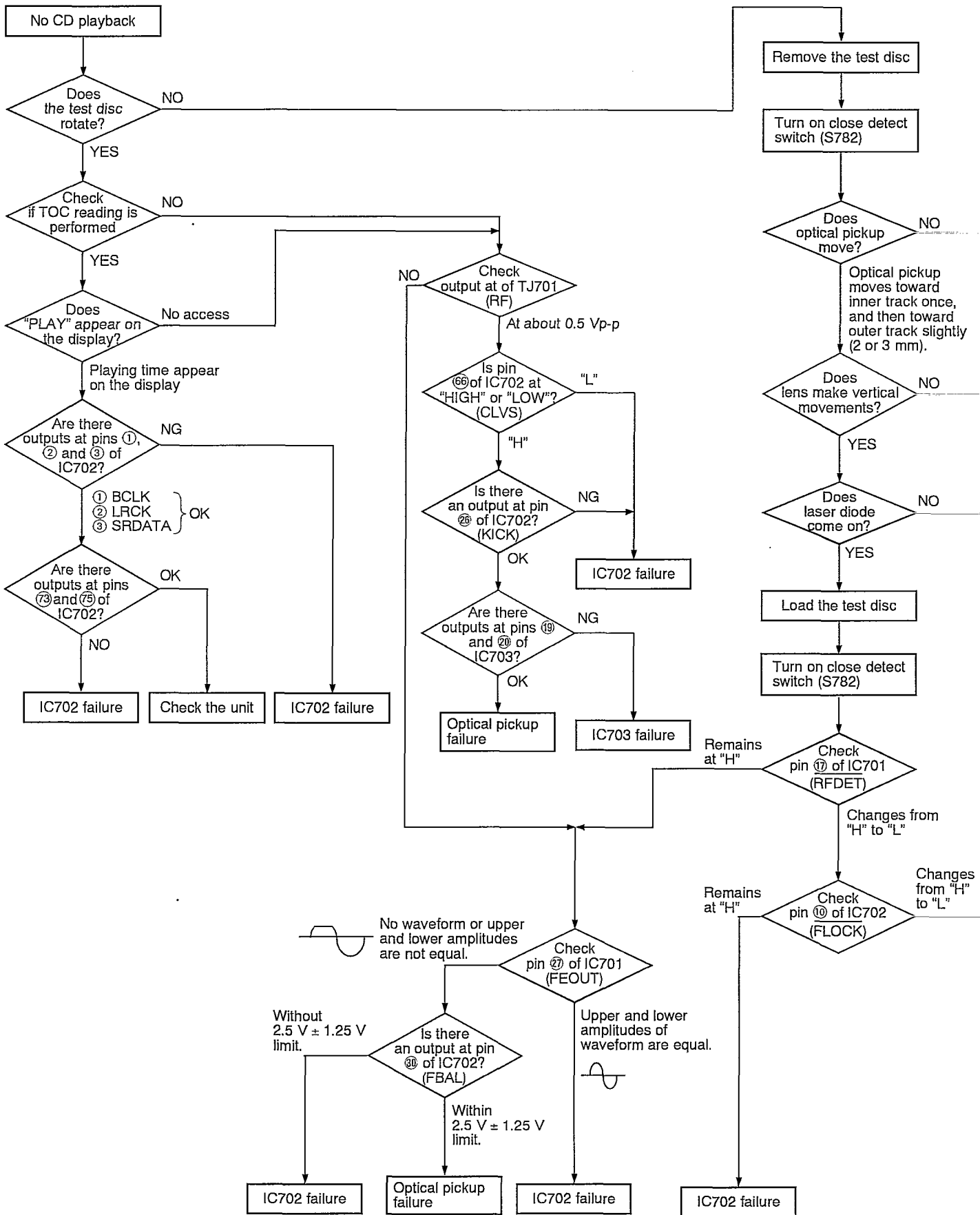

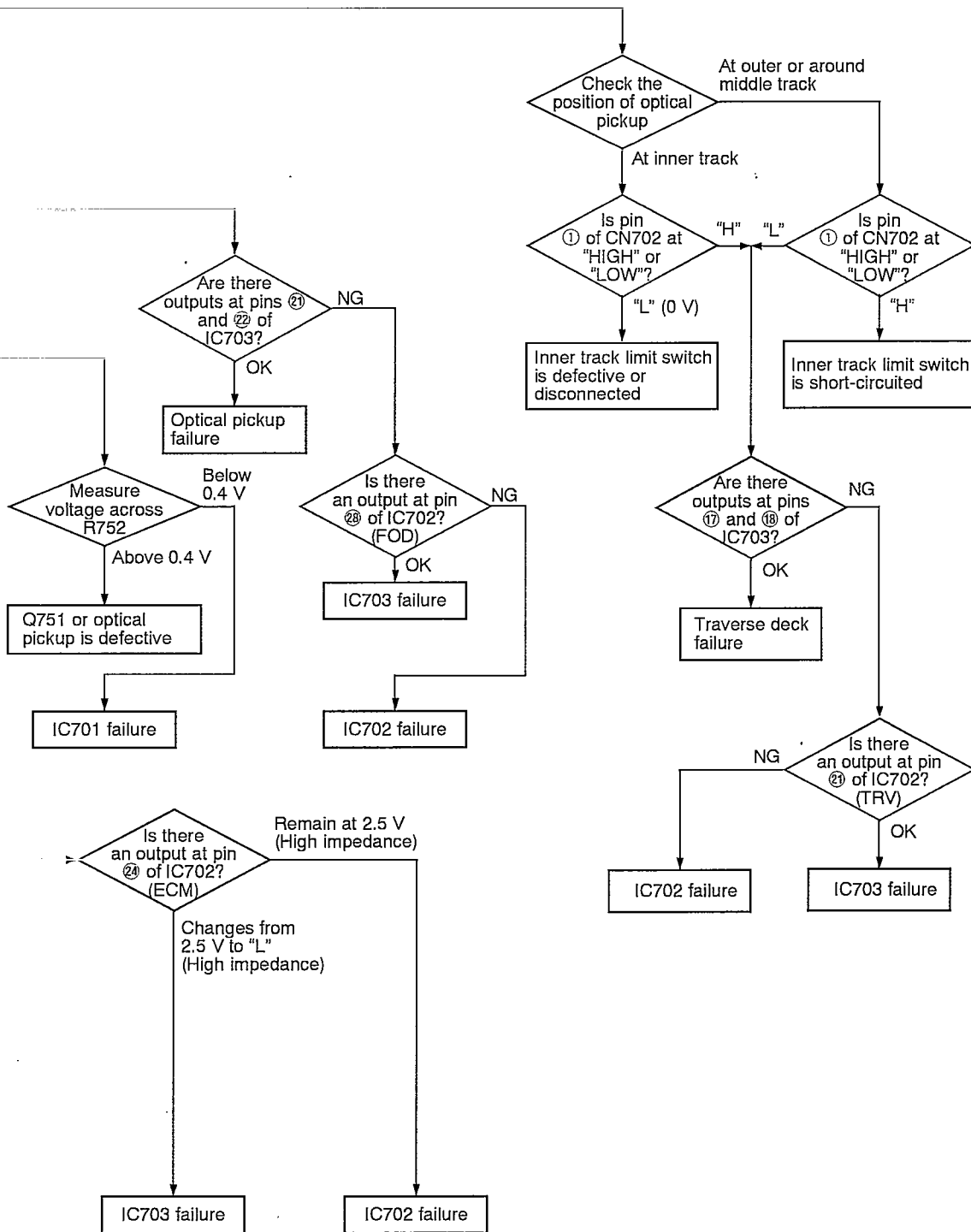

# Replacement Parts List

**Notes:** \*Important safety notice:

Components identified by Δ mark have special characteristics important for safety.

Furthermore, special parts which have purposes of fire-retardant (resistors), high-quality sound (capacitors), low-noise (resistors), etc. are used.

When replacing any of components, be sure to use only manufacturer's specified parts shown in the parts list.

\*The parenthesized indications in the Remarks columns specify the areas. (Refer to the cover page for area.)

Parts without these indications can be used for all areas.

\*Remote Control Ass'y: Supply period for three years from termination of production.

\*[MB] Indicates in Remarks columns parts that are supplied by MBV.

\*Warning: This product uses a laser diode. Refer to caution statements on page 2.

\*ACHTUNG: Die Lasereinheit nicht zerlegen.

Die Lasereinheit darf nur gegen eine vom hersteller spezifizierte einheit ausgetauscht werden.

\*The "(SF)" mark denotes the standard part.

Ref. No.	Part No.	Part Name & Description	Remarks	Ref. No.	Part No.	Part Name & Description	Remarks
		INTEGRATED CIRCUIT (S)					
IC11	LM2940T5	I. C, REGULATOR	Δ			OSCILLATOR (S)	
IC401	UPD78042A014	I. C, SYSTEM CONTROL	[MB]	X401	RSXY4M23M01T	OSCILLATOR (4. 23 MHz)	
IC651	RCD12042TH	I. C, REMOTE SENSOR		X701	RSXZ16M9M01T	OSCILLATOR (16. 9344 MHz)	
IC701	AN8805SBE1	I. C, SERVO AMP.	[MB]			DISPLAY TUBE	
IC702	MN662713RG1	I. C, SERVO PROCESSOR	[MB]	FL601	RSLO201-F	DISPLAY TUBE	[MB]
IC703	AN8389SE1	I. C, MOTOR DRIVE				SWITCH (ES)	
IC781	TA7291SA	I. C, MOTOR DRIVE		S601	EVQ21405R	SW, TIME MODE	
IC801	BA4560FE1	I. C, L. P. F. AMP.	[MB]	S602	EVQ21405R	SW, AUTO CUE	
		TRANSISTOR (S)		S604	EVQ21405R	SW, PEAK SEARCH	
Q11	2SD2037EFTA	TRANSISTOR	Δ	S605	EVQ21405R	SW, RANDOM	
Q12	2SC1740SQ	TRANSISTOR	Δ	S621	EVQ21405R	SW, F. SKIP	
Q13, 14	2SA933SQR	TRANSISTOR	Δ	S622	EVQ21405R	SW, PAUSE	
Q15	2SA933SQR	TRANSISTOR		S623	EVQ21405R	SW, OPEN/CLOSE	
Q16	2SB1238QSTV6	TRANSISTOR	Δ	S624	EVQ21405R	SW, PROGRAM	
Q19, 20	2SD1450RTA	TRANSISTOR		S625	EVQ21405R	SW, REPEAT	
Q21	DTA124ESTP	TRANSISTOR		S626	EVQ21405R	SW, STOP	
Q22	2SC1740SQ	TRANSISTOR		S627	EVQ21405R	SW, PLAY	
Q51, 52	2SC1740SQ	TRANSISTOR		S628	EVQ21405R	SW, R. SKIP	
Q402	2SD1862QSTV6	TRANSISTOR	Δ	S629	EVQ21405R	SW, CLEAR	
Q751	2SA933SQR	TRANSISTOR		S630	EVQ21405R	SW, RECALL	
Q752	2SC1740SQ	TRANSISTOR		S651	EVQ21405R	SW, POWER	
Q801, 802	2SD1450RTA	TRANSISTOR		S781	RSH1A005	SW, TRAY OPEN DET.	
Q851	DTC124EST	TRANSISTOR		S782	RSH1A005	SW, TRAY CLOSE DET.	
Q853	DTA114ESTP	TRANSISTOR				CONNECTOR (S)	
		DIODE (S)		CN401	RJS1A6823	CONNECTOR (23P)	
D11-18	1D3-E	DIODE	[MB] Δ	CN402	RJT029W06VT	CONNECTOR (6P)	
D19	MA4330MTA	DIODE	Δ	CN411	RJU076W24M1	CONNECTOR (24P)	[MB]
D20	1SS254TA	DIODE		CN611	RJT076W24M	CONNECTOR (24P)	[MB]
D21	MA4082MTA	DIODE	Δ	CN701	RJS12Q9ZA	CONNECTOR (12P)	[MB]
D22	MA4091-M	DIODE	Δ	CN702	RJS1A6723-1Q	CONNECTOR (23P)	
D25, 26	1SS254TA	DIODE		CN703	RJT029W06VT	CONNECTOR (6P)	
D51	MA4039MTA	DIODE		CN781	RJP6G17ZA	CONNECTOR (6P)	
D401	MA4056MTA	DIODE	Δ			JACK (S)	
D402	1D3-E	DIODE	[MB]	JK1	SJS9236	AC INLET	Δ
D601	1SS254TA	DIODE		JK801	RJH3201N	LINE OUT	
D605, 606	1SS254TA	DIODE					
D651	SLR-305LC	LED					
D701	1SS254TA	DIODE					
D803, 804	1SS254TA	DIODE					
		TRANSFORMER (S)					
T1	RTP1K4B024	POWER TRANSFORMER	[MB] Δ				

Notes : \* Capacity values are in microfarads ( $\mu\text{F}$ ) unless specified otherwise, P=Pico-farads (pF) F=Farads (F)  
 \* Resistance values are in ohms, unless specified otherwise, 1K=1,000(OHM) , 1M=1,000k(OHM)

Ref. No.	Part No.	Values & Remarks	Ref. No.	Part No.	Values & Remarks	Ref. No.	Part No.	Values & Remarks
		RESISTORS	R763	ERDS2TJ823T	1/4W 82K	C730	ECFR1E104ZF5	25V 0.1U
R1	ERQ16NWR15E	1W 0.15	R764	ERDS2TJ393	1/4W 39K	C731, 732	ECEAOJKA221I	6.3V 220U
R12, 13	ERDS2TJ102	1/4W 1K	R765	ERDS2TJ224T	1/4W 220K	C733	ECFR1E104ZF5	25V 0.1U
R14	ERDS2TJ103	1/4W 10K	R766	ERDS2TJ104	1/4W 100K	C734	ECEA1AKA221I	10V 220U
R15	ERDS2TJ822	1/4W 8.2K	R772, 773	ERDS2TJ220T	1/4W 22	C735-737	ECBT1E223ZF	25V 0.022U
R16	ERDS2TJ680T	1/4W 68	R775, 776	ERDS2TJ392T	1/4W 3.9K	C738	ECFR1C183KR2	16V 0.018U
R17	ERDS2TJ331	1/4W 330	R777	ERDS2TJ102	1/4W 1K	C739	ECBT1C152MR5	16V 1500P
R18	ERDS2TJ473	1/4W 47K	R803, 804	ERDS2TJ224T	1/4W 220K	C740	ECBT1C272MR5	16V 2700P
R19	ERDS2TJ472	1/4W 4.7K	R805, 806	ERDS2TJ822	1/4W 8.2K	C742	ECFR1C273KR2	16V 0.027U
R23	ERDS2TJ103	1/4W 10K	R807, 808	ERDS2TJ123	1/4W 12K	C743	ECBT1E223ZF	25V 0.022U
R28-30	ERDS2TJ103	1/4W 10K	R809-812	ERDS2TJ333	1/4W 33K	C744	ECBT1C822MS5	16V 8200P
R51	ERDS2TJ331	1/4W 330	R813-816	ERDS2TJ102	1/4W 1K	C747, 748	ECBT1C103NS5	16V 0.01U
R52	ERDS2TJ272T	1/4W 2.7K	R817, 818	ERDS2TJ473	1/4W 47K	C751	ECEA1CKA100I	16V 10U
R53, 54	ERDS2TJ472	1/4W 4.7K	R819, 820	ERDS2TJ100	1/4W 10	C752	ECFR1E104ZF5	25V 0.1U
R401	ERDS2TJ102	1/4W 1K	R852	ERDS2TJ222	1/4W 2.2K	C765	ECBT1H331KB5	50V 330P
R403, 404	ERDS2TJ103	1/4W 10K			CAPACITORS	C766	ECBT1H391KB5	50V 390P
R405, 406	ERDS2TJ221	1/4W 220	C1	ECFTD103KXL	50V 0.01U	C767	ECEA1HKN010I	50V 1U
R407	ERDS2TJ101	1/4W 100	C10	ECFR1E104ZF5	25V 0.1U	C768	ECFR1E682KR	25V 6800P
R408-411	ERDS2TJ103	1/4W 10K	C11 $\Delta$	ECA1CM222B	16V 2200U	C769	ECBT1C222MR5	16V 2200P
R413	ERDS2TJ102	1/4W 1K	C12	ECBT1C103NS5	16V 0.01U	C772-775	ECFR1E104ZF5	25V 0.1U
R451-455	ERDS2TJ471	1/4W 470	C14	ECEAOJKA470B	6.3V 47U	C776	ECBT1H180J5	50V 18P
R601	ERDS2TJ220T	1/4W 22	C15 $\Delta$	ECEA1EU101	25V 100U	C777	ECBT1H680J5	50V 68P
R651	ERDS2TJ221	1/4W 220	C16 $\Delta$	ECEA1EU331B	25V 330U	C781	ECEA1AKA101I	10V 100U
R701	ERDS2TJ561	1/4W 560	C17, 18	ECEA1HU101	50V 100U	C803-806	ECBT1H391KB5	50V 390P
R703	ERDS2TJ823T	1/4W 82K	C19	ECEA1EU101	25V 100U	C807, 808	ECEAOJKA470B	6.3V 47U
R707, 708	ERDS2TJ334	1/4W 330K	C22	ECEA1AU331	10V 330U	C809, 810	ECBT1H102KB5	50V 1000P
R709	ERDS2TJ683	1/4W 68K	C401	ECBT1C103NS5	16V 0.01U	C817	ECFR1E104ZF5	25V 0.1U
R711	ERDS2TJ154	1/4W 150K	C404	ECBT1C103NS5	16V 0.01U			
R712	ERDS2TJ221	1/4W 220	C405	ECEAOJKA101B	6.3V 100U			
R717, 718	ERDS2TJ102	1/4W 1K	C451-455	ECBT1H101KB5	50V 100P			
R721	ERDS2TJ101	1/4W 100	C651	ECEAOJKA470I	6.3V 47U			
R722	ERDS2TJ683	1/4W 68K	C703	ECEAOJKA101I	6.3V 100U			
R723	ERDS2TJ183T	1/4W 18K	C704	ECFR1E104ZF5	25V 0.1U			
R724	ERDS2TJ393	1/4W 39K	C705	ECEA1HKA010I	50V 1U			
R725	ERDS2TJ472	1/4W 4.7K	C706	ECBT1H101KB5	50V 100P			
R726	ERDS2TJ474	1/4W 470K	C707	ECFR1C273KR2	16V 0.027U			
R727	ERDS2TJ153	1/4W 15K	C708	ECBT1C472MR5	16V 4700P			
R728	ERDS2TJ822	1/4W 8.2K	C709	ECFR1C473KR2	16V 0.047U			
R731	ERDS2TJ223	1/4W 22K	C714	ECEAOJKA101I	6.3V 100U			
R732	ERDS2TJ183T	1/4W 18K	C716	ECBT1H561KB5	50V 560P			
R733	ERDS2TJ822	1/4W 8.2K	C717	ECFR1E104ZF5	25V 0.1U			
R735, 736	ERDS2TJ101	1/4W 100	C718	RCQ52C0224J9	63V 0.22U [MB]			
R745	ERDS2TJ155	1/4W 1.5M	C721, 722	ECBT1H270J5	50V 27P			
R751	ERDS2TJ102	1/4W 1K	C723	ECEAOJKA221I	6.3V 220U			
R752, 753	ERDS2TJ392T	1/4W 3.9K	C724	ECFR1E104ZF5	25V 0.1U			
R754	ERDS2TJ103	1/4W 10K	C725, 726	ECBT1H102KB5	50V 1000P			
R761, 762	ERDS2TJ103	1/4W 10K	C727, 728	ECEA1HKA010I	50V 1U			

# ■ Cabinet Parts Location

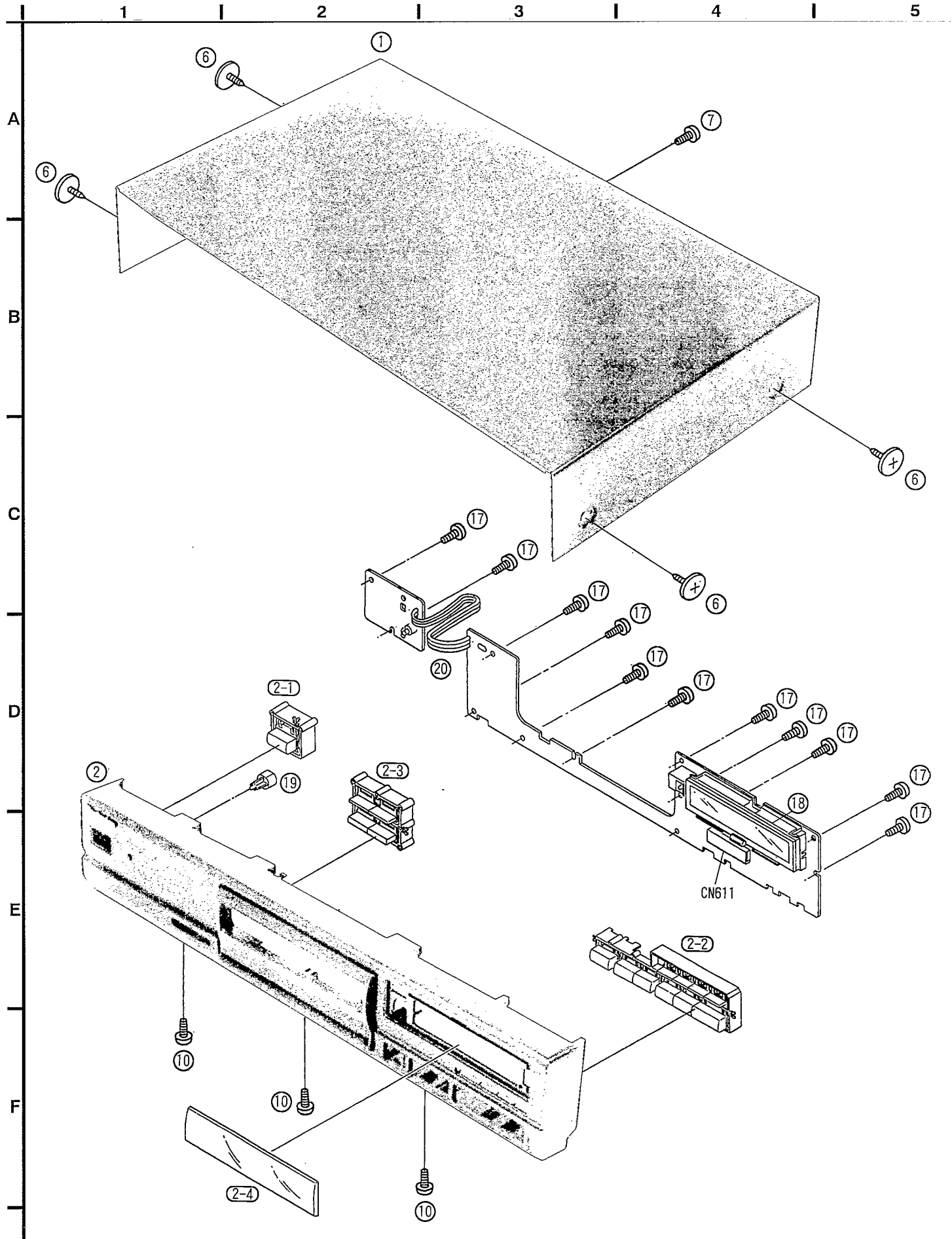



I 6 I 7 I 8 I 9 I 10

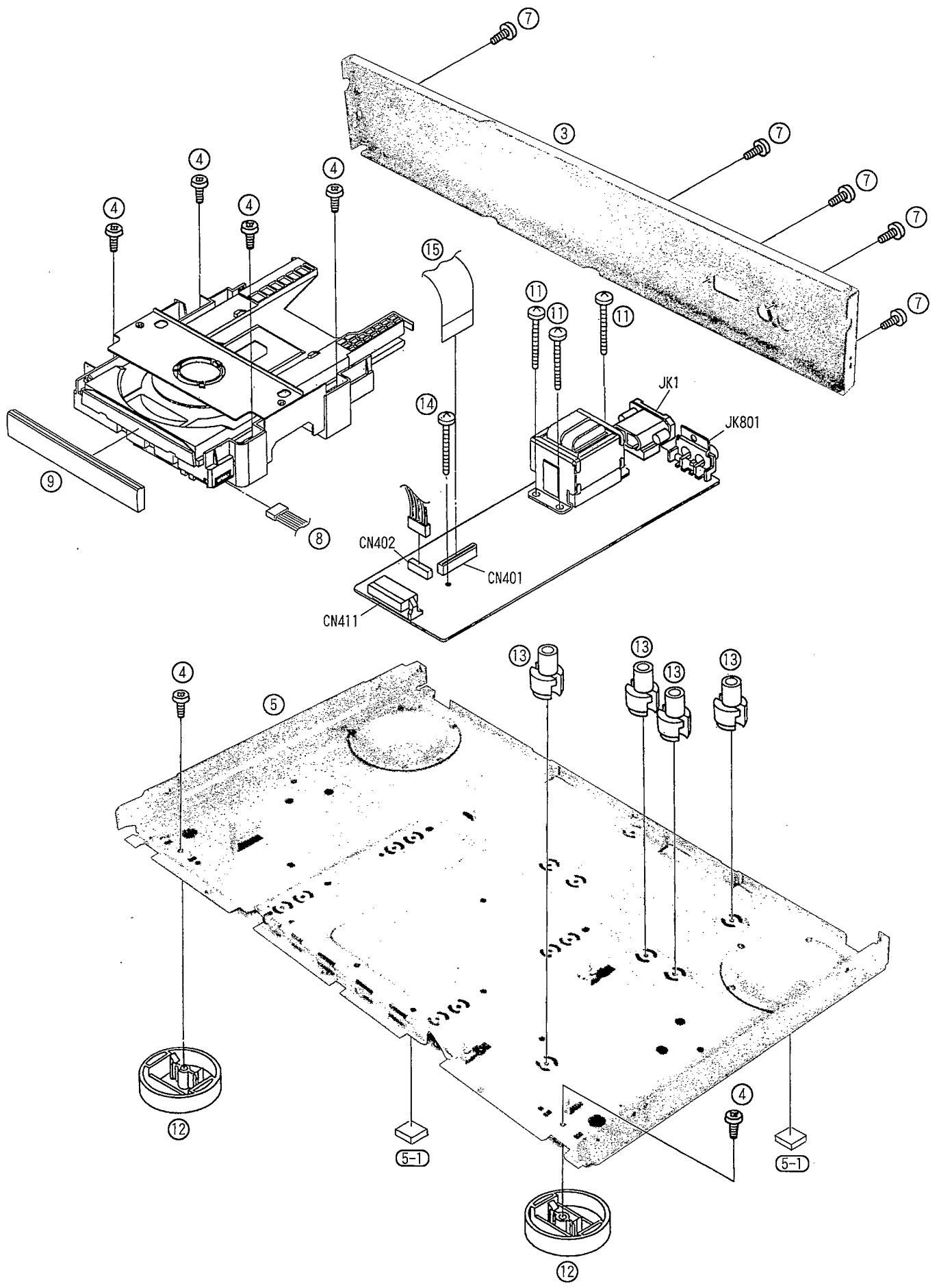

# ■ Loading Unit Parts Location

**Note:**

When changing mechanism parts, apply the specified grease to areas marked "XX" as shown in the drawing.

Ref No.	Part No.
①	RFKXEM30L

A  
B  
C  
D  
E  
F

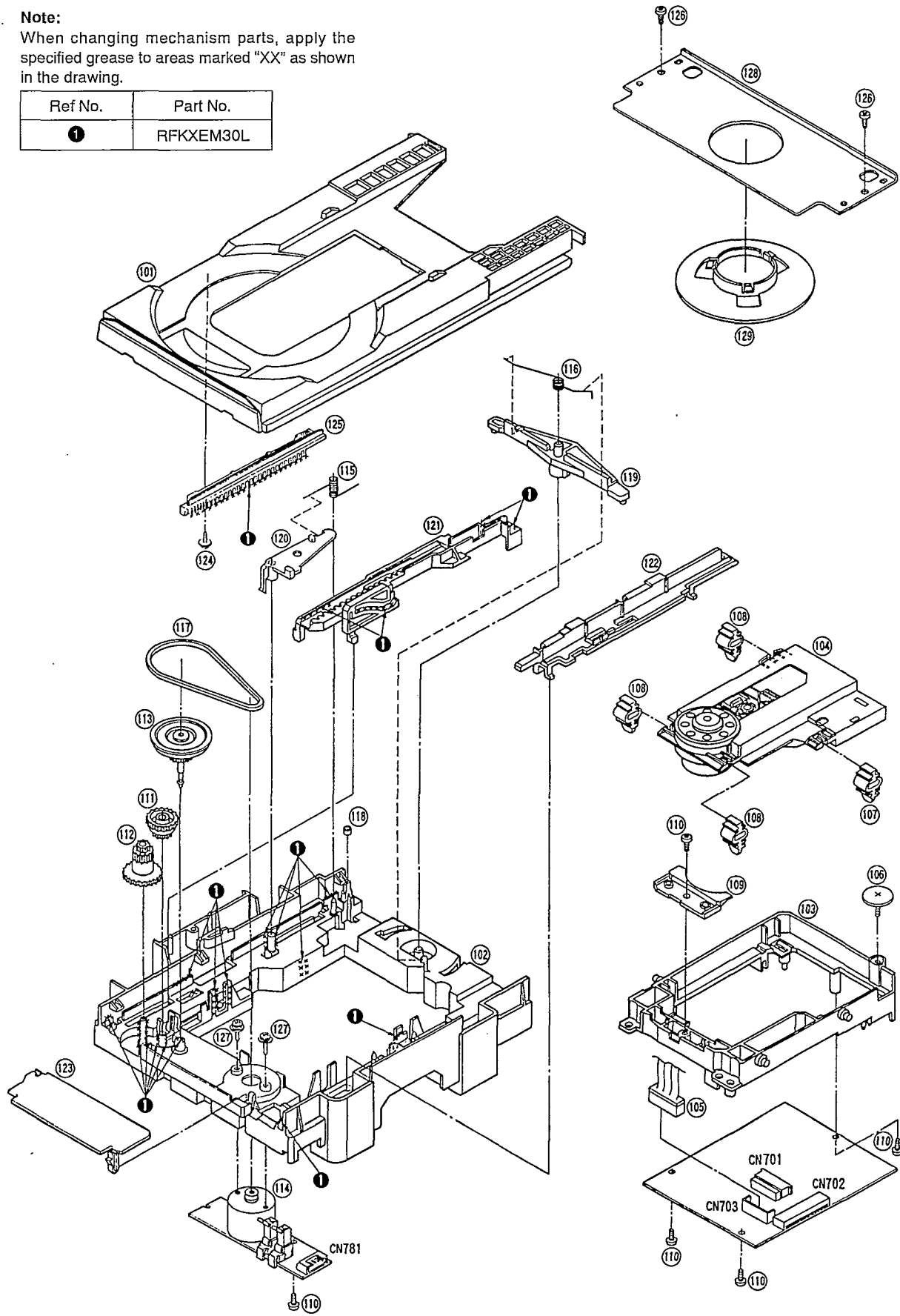

Note: The reference number SA represent the grease and tool used for this unit.

Ref. No.	Part No.	Part Name & Description	Remarks	Ref. No.	Part No.	Part Name & Description	Remarks
		CABINET PARTS					
1	RKMO098-K	CABINET	[MB]	125	RFKRLPG460AA	DRIVE RACK ASS'Y	[MB]
2	RYPO673Z-K	FRONT PANEL ASS'Y	[MB]	126	XTB3+8JFZ	SCREW	
2-1	RGU1029-K	BUTTON, POWER	[MB]	127	XYN2+F6FZ	SCREW	
2-2	RGU1197-K	BUTTON, MAIN	[MB]	128	RFKRLPG460AB	CLAMP BASE ASS'Y	[MB]
2-3	RGU1199-K	BUTTON, SUB	[MB]	129	RFKRLPG460AC	CLAMPER ASS'Y	[MB]
2-4	RKW0378A-R	PANEL	[MB]			PACKING MATERIALS	
3	RFKRLPG480AE	REAR PANEL ASS'Y	[MB] (EB)	P1	RPG2960	PACKING CASE	[MB]
3	RGR0154E-K	REAR PANEL	[MB] (E, EG)	P2	RPN0861	CUSHION	[MB]
4	XTB3+8JFZ	SCREW		P3	XZB23X35C03	PROTECTION COVER	
5	RFKJLPG370AE	BOTTOM CHASSIS ASS'Y	[MB]	P4	SPP730	PROTECTION COVER	
5-1	RMGO384-T	FOOT	[MB]			ACCESSORIES	
6	RHD30035-K1	SCREW		A1	EUR643900	REMOTE CONTROL	[MB]
7	XTBS3+8JFZ1	SCREW		A1-1	UR64EC1638	BATTERY COVER	[MB]
8	REX0577-1	CABLE ASS'Y (6P)	[MB]	A2	RJA0043-C	AC MAINS LEAD	[MB] Δ (E, EG)
9	RGK0703-K	ORNAMENT	[MB]	A2	RJA0044-C	AC MAINS LEAD	[MB] Δ (EB)
10	XTB3+10JFZ	SCREW		A3	RFKSLPG580AE	INSTRUCTIONS MANUAL ASS'Y	[MB] (E)
11	RHD30053	SCREW	[MB]	A3	RQT3479-B	INSTRUCTIONS MANUAL	[MB] (EB)
12	RKA0040B-K1	FOOT	[MB]	A3	RQT3477-D	INSTRUCTIONS MANUAL	[MB] (EG)
13	RMRO377-1	P. C. B. SUPPORT	[MB]	A4	SJP2249-3	STEREO CONNECTION CABLE	
14	XTBR3+20JFZ	SCREW	[MB]	A5	RQA0117	WARRANTY CARD	
15	RWJ5223130EE	FFC (23P)	[MB]	A6	RQCB0169	SERVICE CENTER LIST	
17	RHD26021	SCREW	[MB]			GREASE OR TOOL	
18	RMRO826-K	FL HOLDER	[MB]	SA1	RFKXEM30L	GREASE	
19	RGL0267-Q	LED INDICATOR	[MB]	SA2	SZZP1054C	TEST DISC	
20	RWJ1803150KK	FLAT CABLE (3P)					
		LOADING UNIT PARTS					
101	RGQ0130-K	TRAY	[MB]				
102	RFKJLPG460AE	MECHANISM CHASSIS ASS'Y	[MB]				
103	RMRO719-W1	MID. CHASSIS	[MB]				
104	RAE1100Z-2	TRAVERSE UNIT	[MB]				
105	REX0576	CABLE ASS'Y	[MB]				
106	RHD30047	SCREW	[MB]				
107	RMGO337-K	DAMPING RUBBER	[MB]				
108	RMGO337-Q	DAMPING RUBBER	[MB]				
109	RMRO750-W	STOPPER	[MB]				
110	XTBS26+8J	SCREW					
111	RDG0142	RELAY GEAR					
112	RDG0259	DRIVE GEAR	[MB]				
113	RDPO065	RELAY PULLY					
114	REM0047	MOTOR ASS'Y	[MB]				
115	RME0063	LOCK LEVER SPRING					
116	RME0087	ASSIST SPRING					
117	RMGO158	BELT					
118	RMGO338-Q	STOPPER RUBBER	[MB]				
119	RML0177	CHANGE LEVER					
120	RML0178-1	LOCK LEVER					
121	RMMD0112	SLIDE PLATE 1	[MB]				
122	RMMD0113	SLIDE PLATE 2	[MB]				
123	RMRO721-K	GEAR COVER	[MB]				
124	RHD20009-1	SCREW					

## ■ Packaging

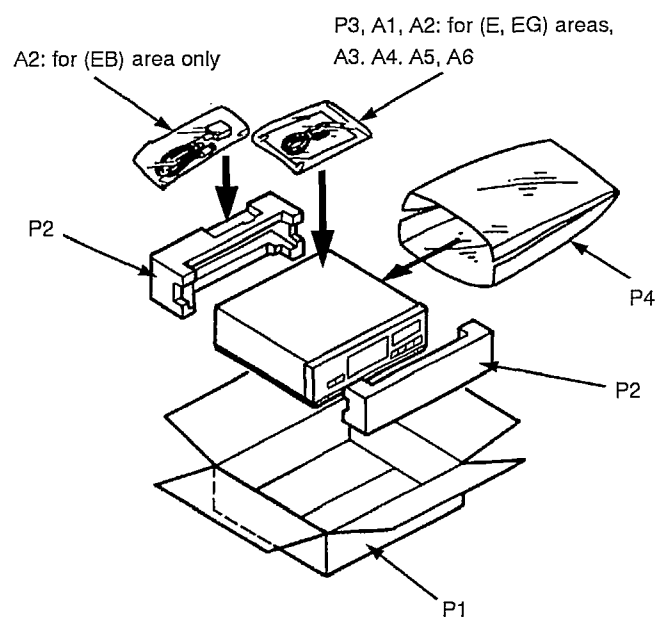

1166