

Service Manual

Compact Disc Player

SL-PG540A

COMPACT
disc
DIGITAL AUDIO

DIGITAL

MASH*
multi-stage noise shaping

Colour

(K) Black Type

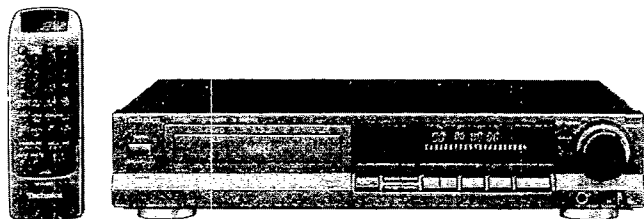

Area

Suffix for Model No.	Area	Colour
(E)	Europe	(K)
(EB)	Great Britain	
(EG)	Germany and Italy	

*

- Technics (or Panasonic) developed the world's first MASH type DAC and ADC. MASH technology was invented by NTT (LSI Labs).
- MASH is a trademark of NTT.

SL-PG320A TRAVERSE DECK SERIES (RAD0301-1) SPECIFICATIONS

(DIN 45 500)

■ Audio

No. of channels	2 (left and right, stereo)
Frequency response	2–20,000 Hz, ± 0.5 dB
Output voltage	2 V (at 0 dB)
Dynamic range	98 dB
S/N	105 dB
Harmonic distortion	0.002% (1 kHz, 0 dB)
Total harmonic distortion	0.0027% (1 kHz, 0 dB)
Wow and flutter	Below measurable limit
DA converter	MASH (1 bit)
Output impedance	600 Ω
Load impedance	More than 10 k Ω
Headphone output level	15 mW max. 32 Ω (adjustable)

■ Pickup

Wavelength	780 nm
Laser Power	No hazardous radiation is emitted (with safety protection)

■ General

Power consumption	10 W
Power supply	AC 50/60 Hz, 230–240 V
Dimensions (W×H×D)	430×92×298 mm
Weight	3.6 kg

Note:

Specifications are subject to change without notice.
Weight and dimensions are approximate.

Technics

■ CONTENTS

	Page		Page
HANDLING PRECAUTIONS FOR TRAVERSE DECK	2	CHECKING OF THE MAIN P.C.B.	13
PRECAUTION OF LASER DIODE	2	MEASUREMENTS AND ADJUSTMENTS	14, 15
ACCESSORIES	3	TROUBLESHOOTING GUIDE	16~18
INSTALLATION	3	BLOCK DIAGRAM	19, 20
CAUTION FOR AC MAINS LEAD	4	SCHEMATIC DIAGRAM	21~26
CONCERNING COMPACT DISCS	5	PRINTED CIRCUIT BOARD DIAGRAM	27~30
CLEANING OF LENS	5	WIRING CONNECTION DIAGRAM	31
CONNECTIONS	6	TERMINAL FUNCTION OF IC'S	32~35
LOCATION OF CONTROLS	6, 7	REPLACEMENT PARTS LIST	36~40
BASIC OPERATING PROCEDURE	8	PACKAGING	39
DISASSEMBLY INSTRUCTIONS	9~12	CABINET PARTS LOCATION	41, 42
CHECKING OF THE SERVO P.C.B.	12	LOADING UNIT PARTS LOCATION	43

■ HANDLING PRECAUTIONS FOR TRAVERSE DECK

The laser diode in the traverse deck (optical pickup) may break down due to potential difference caused by static electricity of clothes or human body.

So, be careful of electrostatic breakdown during repair of the traverse deck (optical pickup).

● Handling of traverse deck (optical pickup)

1. Do not subject the traverse deck (optical pickup) to static electricity as it is extremely sensitive to electrical shock.
2. To prevent the breakdown of the laser diode, an anti-static shorting pin is inserted into the flexible board (FPC board).
When removing or connecting the short pin, finish the job in as short time as possible.
3. Take care not to apply excessive stress to the flexible board (FPC board).

● Grounding for electrostatic breakdown prevention

1. Human body grounding
Use the anti-static wrist strap to discharge the static electricity from your body.
2. Work table grounding
Put a conductive material (sheet) or steel sheet on the area where the traverse deck (optical pickup) is placed, and ground the sheet.

Caution:

The static electricity of your clothes will not be grounded through the wrist strap. So, take care not to let your clothes touch the traverse deck (optical pickup).

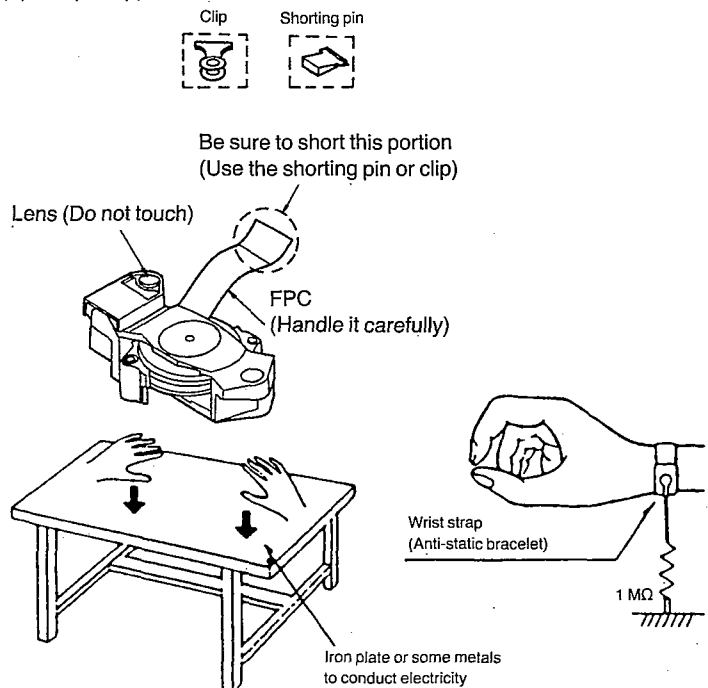

■ PRECAUTION OF LASER DIODE

CAUTION: This product utilizes a laser diode with the unit turned "on", invisible laser radiation is emitted from the pick up lens.
Wave length: 780 nm
Maximum output radiation power from pick up: 100 μ W/VDE

Laser radiation from the pick up unit is safety level, but be sure the followings:

1. Do not disassemble the optical pick up unit, since radiation from exposed laser diode is dangerous.
2. Do not adjust the variable resistor on the pickup unit. It was already adjusted.
3. Do not look at the focus lens using optical instruments.
4. Recommend not to look at pick up lens for a long time.

ACHTUNG: Dieses produkt enthält eine laserdiode. Im eingeschalteten zustand wird unsichtbare laserstrahlung von der lasereinheit abgestrahlt.

Wellenlänge: 780 nm
Maximale strahlungsleistung der lasereinheit: 100 μ W/VDE

Die strahlung an der lasereinheit ist ungefährlich, wenn folgende punkte beachtet werden:

1. Die lasereinheit nicht zerlegen, da die strahlung an der freigelegten laserdiode gefährlich ist.
2. Den werksseitig justierten einstellregler der lasereinheit nicht verstellen.
3. Nicht mit optischen instrumenten in die fokussierlinse blicken.
4. Nicht über längere zeit in die fokussierlinse blicken.

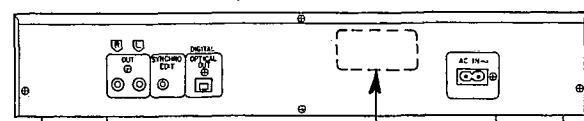

**CLASS 1
LASER PRODUCT**

**LUOKAN 1 LASERLAITE
KLASS 1 LASER APPARAT**

ACCESSORIES

Note:

The configuration of the AC power supply cord differs according to area.

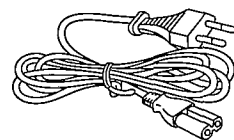

AC power supply cord
for (E) and (EG) areas...(RJA0018-K) 1

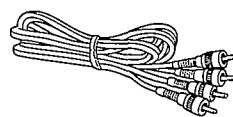

Stereo connection cable
(SJP2249-3) 1

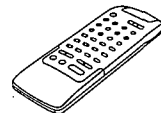

Remote control transmitter
(EUR642100) 1

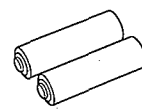

Batteries
UM-4 (AAA, R03) 2
for remote control transmitter

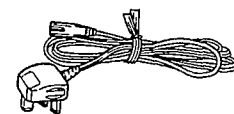

for (EB) area...(VJA0733) 1

INSTALLATION

Before placement

Two transport security devices are secured to prevent the optical pickup from damage during transport. Be sure to release them before use.

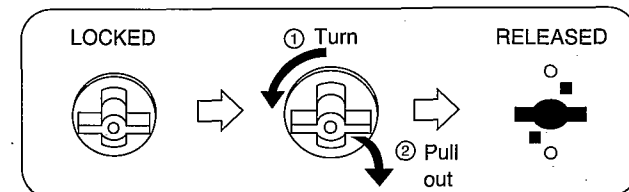

Insert them here after removing.
Turn clockwise by 90° to secure them.

Soft cloth or similar material
(to prevent scratches)

Note:

When transporting the unit, be sure to remove the compact disc from inside the unit. And replace the transport security devices again following the reverse order not to damage the optical pickup.

VARO!
AVATTAESSA JA SUOJALUKITUS-
OHITETTAESSA OLET ALTTIINA
NÄKYMÄTÖN LASERSÄTEILYLLE.
ÄLÄ KATSO SÄTEESÄN.

VARNING
OSYNLIG LASERSTRÅLNING NÄR
DENNA DEL ÄR ÖPPNAD OCH
SPÄRREN ÄR URKOPPLAD.
BETRÄKTA EJ STRÅLEN.

ADVERSEL
USYNLIG LASERSTRÅLNING NÄR
DEKSEL ÖPPNES OG SIKKERHEDSLÅS
BRYTES. UNNGÅ EKSPONERING FOR
STRÅLEN. R01S0074

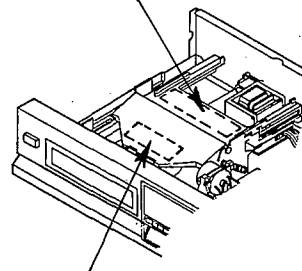

ADVARSEL: USYNLIG LASERSTRÅLNING
VED ÅBNING, NÄR SIKKERHEDSAF-
BRYDERE ER UDE AF FUNKTION.
UNDGÅ UDSÆTTELSE FOR STRÅLING.

VORSICHT
Unsichtbare
Laserstrahlung, wenn
Abdeckung geöffnet.
Nicht dem Strahl
aussetzen. R01S0022

CAUTION FOR AC MAINS LEAD



(For United Kingdom)

("EB" area code model only)

For your safety, please read the following text carefully.

This appliance is supplied with a moulded three pin mains plug for your safety and convenience.

A 5-ampere fuse is fitted in this plug.

Should the fuse need to be replaced please ensure that the replacement fuse has a rating of 5-ampere and that it is approved by ASTA or BSI to BS1362. Check for the ASTA mark  or the BSI mark  on the body of the fuse.

If the plug contains a removable fuse cover you must ensure that it is refitted when the fuse is replaced.

If you lose the fuse cover the plug must not be used until a replacement cover is obtained.

A replacement fuse cover can be purchased from your local dealer.

CAUTION!

IF THE FITTED MOULDED PLUG IS UNSUITABLE FOR THE SOCKET OUTLET IN YOUR HOME THEN THE FUSE SHOULD BE REMOVED AND THE PLUG CUT OFF AND DISPOSED OF SAFELY.

THERE IS A DANGER OF SEVERE ELECTRICAL SHOCK IF THE CUT OFF PLUG IS INSERTED INTO ANY 13-AMPERE SOCKET.

If a new plug is to be fitted please observe the wiring code as shown below.

If in any doubt please consult a qualified electrician.

IMPORTANT

The wires in this mains lead are coloured in accordance with the following code:

Blue: Neutral, Brown: Live.

As these colours may not correspond with the coloured markings identifying the terminals in your plug, proceed as follows:

The wire which is coloured Blue must be connected to the terminal which is marked with the letter N or coloured Black or Blue.

The wire which is coloured Brown must be connected to the terminal which is marked with the letter L or coloured Brown or Red.

WARNING: DO NOT CONNECT EITHER WIRE TO THE EARTH TERMINAL WHICH IS MARKED WITH THE LETTER E, BY THE EARTH SYMBOL  OR COLOURED GREEN OR GREEN/YELLOW.

THIS PLUG IS NOT WATERPROOF—KEEP DRY.

Before use

Remove the connector cover as follows.

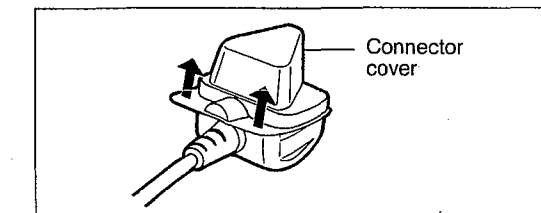

How to replace the fuse

1. Open the fuse cover with a screwdriver.

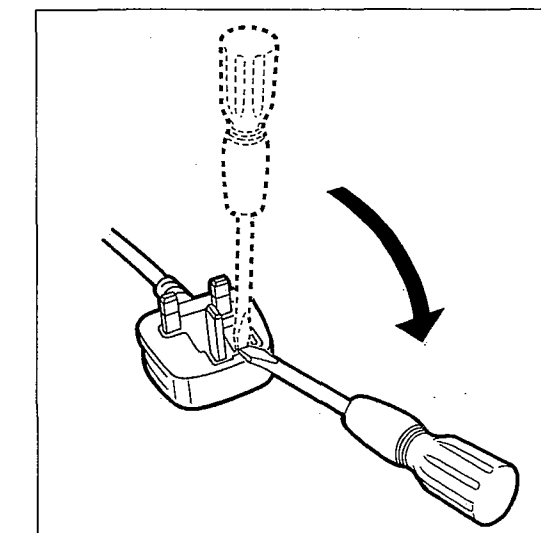

2. Replace the fuse.

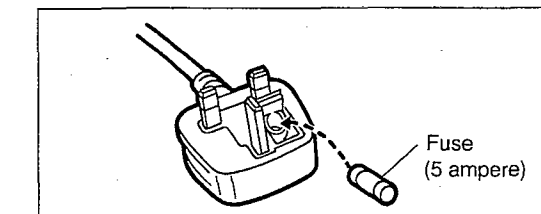

3. Close the fuse cover.

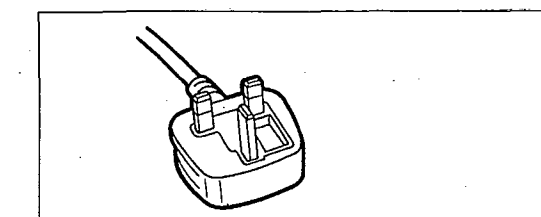

CONCERNING COMPACT DISCS

Only compact discs having this mark can be used with this unit.



Handling precautions

To open the case, gently press the sides of the top, holding the top at both sides.

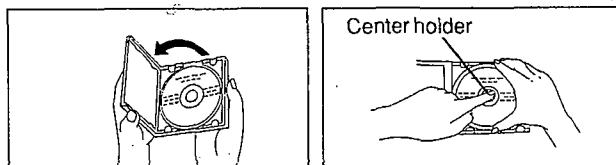

Center holder

- To remove the disc from the case, press the center holder and lift the disc, holding by the edges.
- To return the disc to the case, insert the disc with label facing up and press downward at the center.
- Hold compact discs by the edges so the surface is not soiled with fingerprints. Fingerprints, dirt and scratches can cause skipping and distortion.

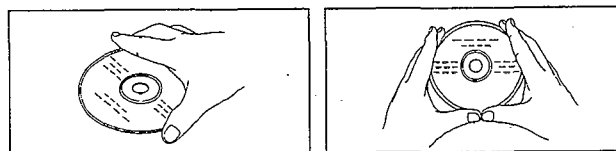

CLEANING OF LENS

If the lens is stained causing sound skip or operation failure, open the top cover by pressing the open button, and clean the lens.

To remove dust or dirt

Blow the lens with the blower provided in the cleaning kit to remove dust or dirt.

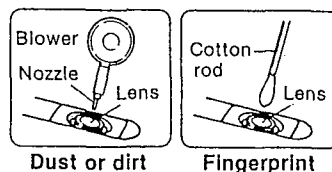

Dust or dirt

Fingerprint

To remove fingerprint

If the blower is not enough, moisten the cotton rod with the lens cleaner solution and wipe the lens with it from center of the lens to outside.

- Do not use record cleaning sprays, benzine, thinner, static electricity prevention liquids or any other solvent.
- If the surface is soiled, wipe gently with a soft, damp (water only) cloth.
- Always move the cloth directly outward from the center of the disc, not in a circular motion as with standard phonograph records.

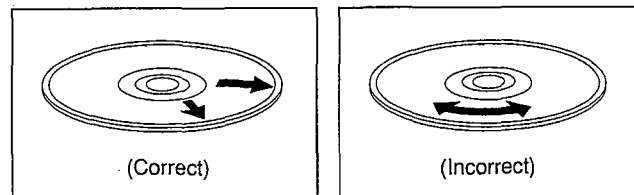

- If the disc is brought from a cold to a warm environment, moisture may form on the disc. Wipe this off with a soft, dry, lint-free cloth before using the disc.
- Do not write on the label side with a ball-point pen or other writing instrument.

Storage precautions

Be sure to store discs in their cases to protect them from dust, scratches and warping.

Do not place or store discs in the following places:

- Locations exposed to direct sunlight.
- Humid or dusty locations.
- Locations directly exposed to a heat outlet or heating appliance.
- In the glove compartment or rear ledge of an automobile.

Cautions:

- Do not directly apply the cleaner solution to the lens. Do not apply too much solution to the cotton rod or otherwise the solution will flow into the player.
- Wipe the lens carefully. Do not give too much stress to the lens or otherwise it may scratch the lens or cause optical pickup trouble.
- If the solution should be too much applied, wipe the lens with a dry cotton rod.

Lens cleaning kit (Part No. : SZZP1038C)

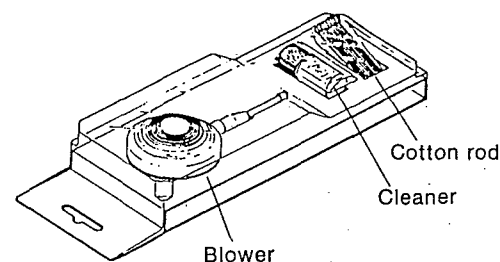

CONNECTIONS

Before making connections, be sure that the power of this unit and all other system components is first turned off.

See the operating instructions of the amplifier or the cassette deck for details.

Note:

The configuration of the AC outlet and AC power supply cord differs according to area.

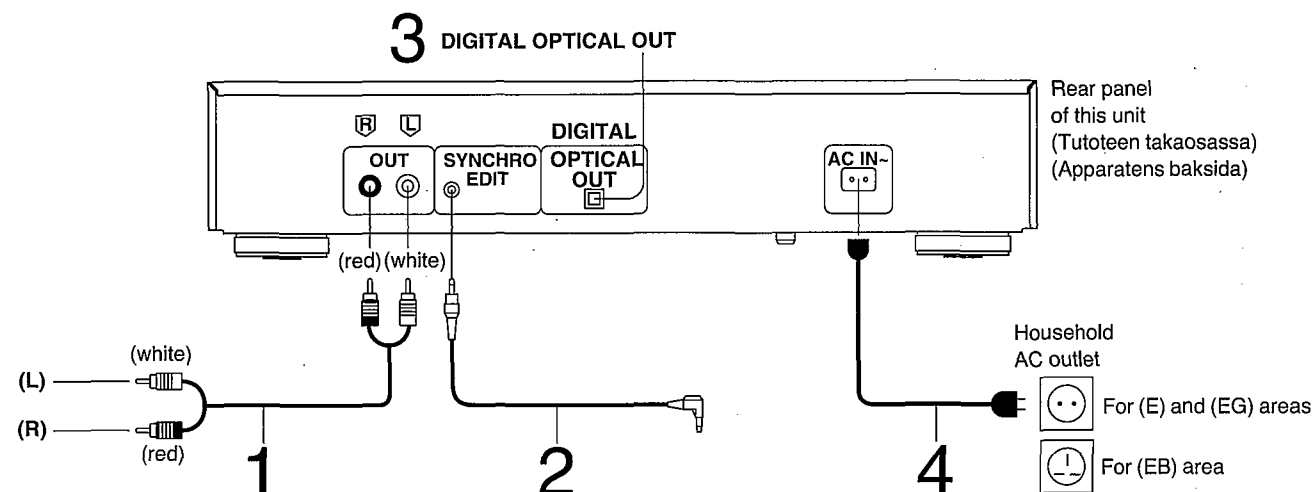

1 Connect the stereo connection cable (included) to the "CD" or "AUX" terminals of the amplifier.

2 Connect the synchro edit cable (included with the cassette deck) to the "SYNCHRO EDIT" terminal of the Technics cassette deck.

3 Connect the optical-fiber cable (not included) to the "DIGITAL INPUT" terminal of the amplifier.

This terminal can be used for connection with other equipment that has a digital input terminal, such as an amplifier, by using an optical-fiber cable (not included). A dust-protection cap is inserted in this terminal. Remove this cap only when a connection is to be made to this terminal.

4 Connect the AC power supply cord (included) to the "AC OUTLET" of the amplifier or the household AC outlet.

Insertion of Connector

Even when the connector is perfectly inserted, depending on the type of inlet used, the front part of the connector may jut out as shown in the drawing. However there is no problem using the unit.

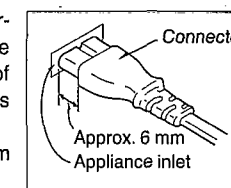

LOCATION OF CONTROLS

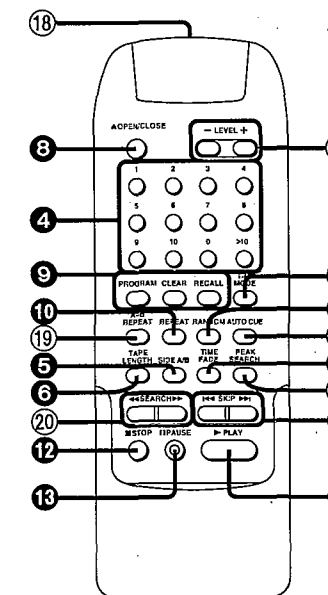
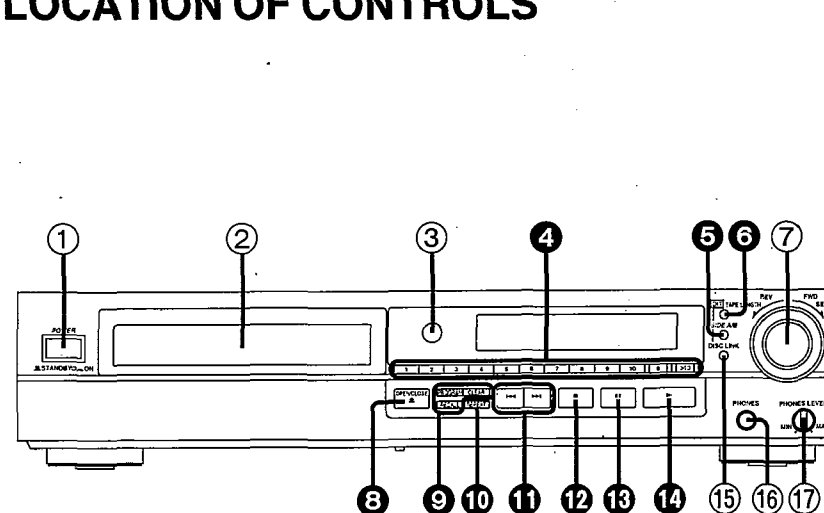

Control section

Numbers with black background (for example 4) indicate functions available on the remote control.

- ① **Power "STANDBY \cup /ON" switch (POWER, \blacksquare STANDBY \cup \blacksquare ON)**
This switch switches ON and OFF the secondary circuit power only. The unit is in the "standby" condition when this switch is set to the STANDBY \cup position. Regardless of the switch setting, the primary circuit is always "live" as long as the power cord is connected to an electrical outlet.
- ② **Disc tray**
- ③ **Remote control signal sensor (SENSOR)**
- ④ **Numeric buttons (1–10, 0, >10)**
- ⑤ **Tape side select button (SIDE A/B)**
- ⑥ **Tape length button (TAPE LENGTH)**
- ⑦ **Search dial (SEARCH)**
- ⑧ **Disc tray open/close button (\blacktriangle OPEN/CLOSE)**
- ⑨ **Buttons for program function**
 - Program button (PROGRAM)
 - Clear button (CLEAR)
 - Recall button (RECALL)
- ⑩ **Repeat button (REPEAT)**
- ⑪ **Skip buttons (\blacktriangleleft , \blacktriangleright)**
- ⑫ **Stop button (\blacksquare)**

- ⑬ **Pause button (\parallel)**
- ⑭ **Play button (\blacktriangleright)**
- ⑮ **Disc link button (DISC LINK)**
- ⑯ **Headphones jack (PHONES) (\varnothing 6, 32 Ω)**
- ⑰ **Headphones volume control (PHONES LEVEL)**

Remote control section

The functions indicated by numbers with black background (for example 4) are described under "Control section" on page 7.

- ⑱ **Remote control transmission window**
- ⑲ **A-B repeat button (A-B REPEAT)**
- ⑳ **Search buttons (\blacktriangleleft SEARCH \blacktriangleright)**
- ㉑ **Level control buttons ($-$ LEVEL $+$)**
- ㉒ **Time mode select button (TIME MODE)**
- ㉓ **Random play button (RANDOM)**
- ㉔ **Auto cue button (AUTO CUE)**
- ㉕ **Time fade button (TIME FADE)**
- ㉖ **Peak search button (PEAK SEARCH)**

Display section

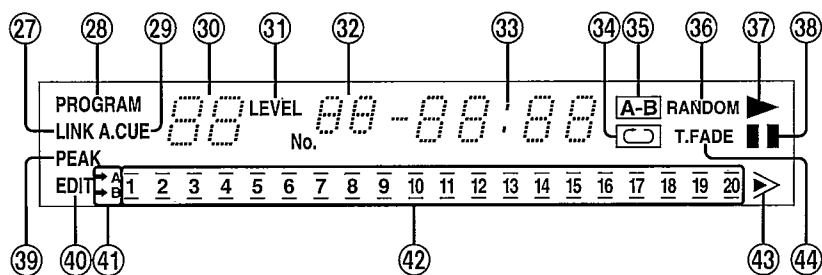

- ⑳ **Disc link indicator (LINK)**
- ㉑ **Program indicator (PROGRAM)**
- ㉒ **Auto cue indicator (A.CUE)**
- ㉓ **Track number display**
- ㉔ **Level control indicator (LEVEL)**
- ㉕ **Index/program sequence display**
- ㉖ **Time display**
- ㉗ **Repeat indicator (\square)**
- ㉘ **A-B repeat indicator ($\overline{A-B}$)**
- ㉙ **Random play indicator (RANDOM)**
- ㉚ **Play indicator (\blacktriangleright)**
- ㉛ **Pause indicator (\parallel)**
- ㉜ **Peak search indicator (PEAK)**
- ㉝ **Compact disc edit indicator (EDIT)**
- ㉞ **Tape side indicator (\rightarrow A, \rightarrow B)**
- ㉟ **Track number indicator ($\overline{1-20}$)**
- ㊱ **"Over" mark (\blacktriangleright)**
- ㊲ **Time fade/fade out indicator (T.FADE)**

■ BASIC OPERATING PROCEDURE

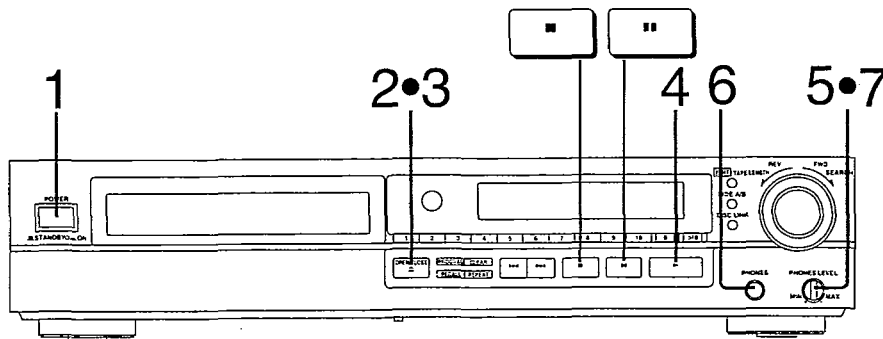

1 Press POWER to switch on the power.
If there is a disc in the disc tray, play will start from the first track.

2 Press open/close button ▲ to open the disc tray and insert a disc.
(Also available from the remote control)

Label must face upward.

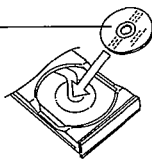

Before attempting to use the remote control transmitter to open the disc tray, make sure that there are no obstructions in front of the unit.

3 Press open/close button ▲ again to close the disc tray.
(Also available from the remote control)

Total number of tracks Total playing time

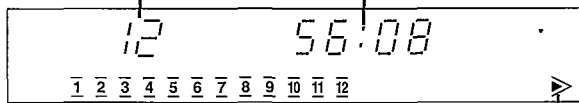

Lights when the total number of tracks exceeds 21

- The total playing time displayed includes the silent sections between tracks. For this reason, it may be a few seconds longer than the playing time indicated on the disc.
- You can skip this step and press play button ►. The disc tray will be automatically closed and then play will start from the first track.

4 Press play button ►.
(Also available from the remote control)

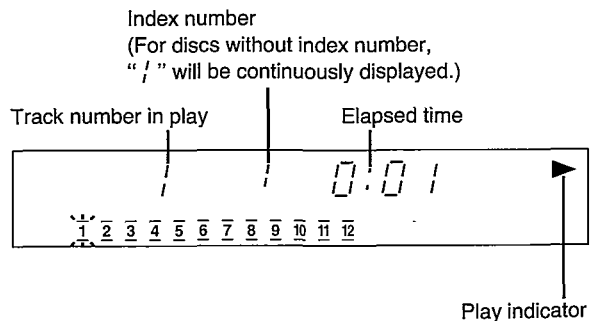

The unit stops automatically when the last track finishes playing.

To stop disc play

(Also available from the remote control)

Press stop button ■.



To temporarily stop disc play

(Also available from the remote control)

Press pause button ■■.



Pause indicator

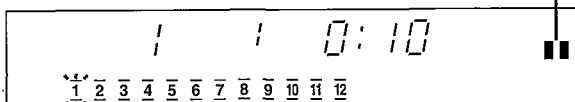

Press play button ► to resume play.

How to use headphones (not included)

5 Reduce the headphones volume level.

6 Connect the headphones to the headphones jack.

Plug type: Stereo large plug

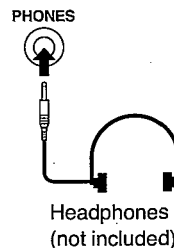

7 Adjust the volume.

Avoid listening for prolonged periods of time to prevent hearing damage.

DISASSEMBLY INSTRUCTIONS

Warning: This product uses a laser diode. Refer to caution statements on page 2.

ACHTUNG: Die Lasereinheit nicht zerlegen.

Die Lasereinheit darf nur gegen eine vom Hersteller spezifizierte Einheit ausgetauscht werden.

"ATTENTION SERVICER" Some chassis components may have sharp edges. Be careful when disassembling and servicing.

* This CD player is equipped with FPC boards, so handle them with care during disassembly and reassembly.

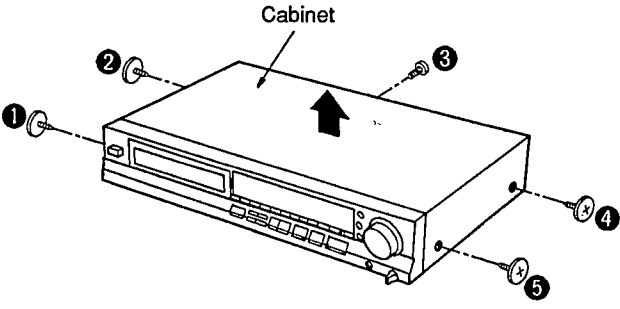
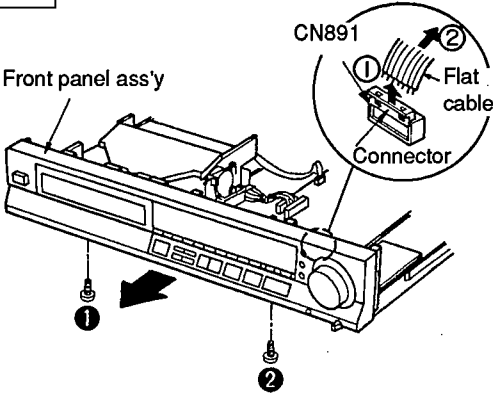
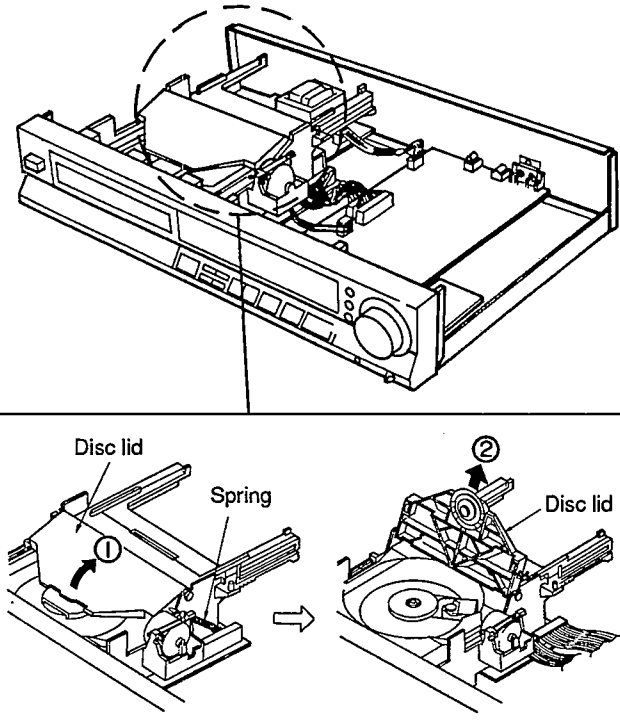
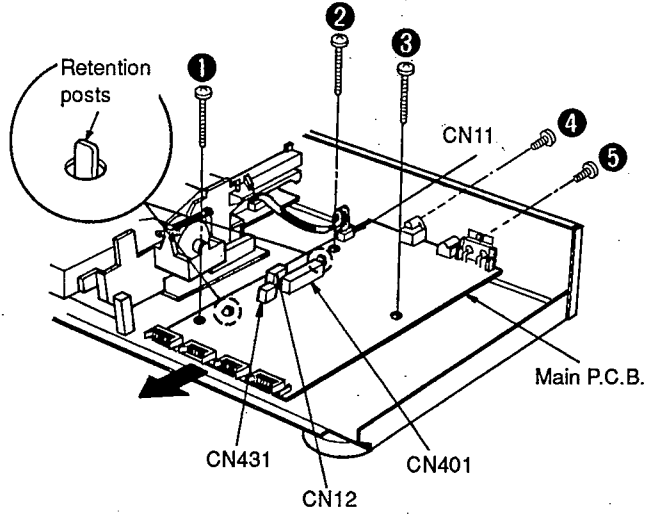
Ref. No. 1	Removal of the cabinet	Ref. No. 2	Removal of the front panel ass'y
Procedure 1		Procedure 1→2	
	 <ol style="list-style-type: none"> 1. Remove the 5 screws (①~⑤). 2. Remove the cabinet in the direction of arrow. 		 <ol style="list-style-type: none"> 1. Remove the 1 connector (CN891). 2. Remove the 2 screws (①, ②). 3. Remove the front panel ass'y in the direction of arrow.
Ref. No. 3	Removal of the disc lid	Ref. No. 4	Removal of the main P.C.B.
Procedure 1→3	<ol style="list-style-type: none"> 1. Remove the spring. 2. Move the disc lid in the direction of arrow ① and pull out this in the direction of arrow ②. 	Procedure 1→4	
			 <ol style="list-style-type: none"> 1. Remove the 4 connectors (CN11, CN12, CN401, CN431). 2. Remove the 5 screws (①~⑤). 3. Lift the main P.C.B. off the retention posts on the chassis. 4. Remove the main P.C.B. in the direction of arrow.

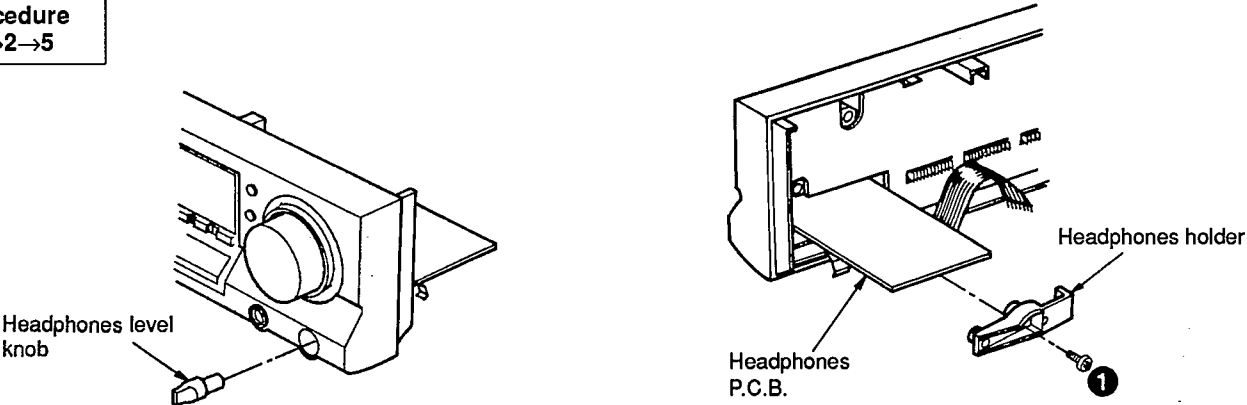
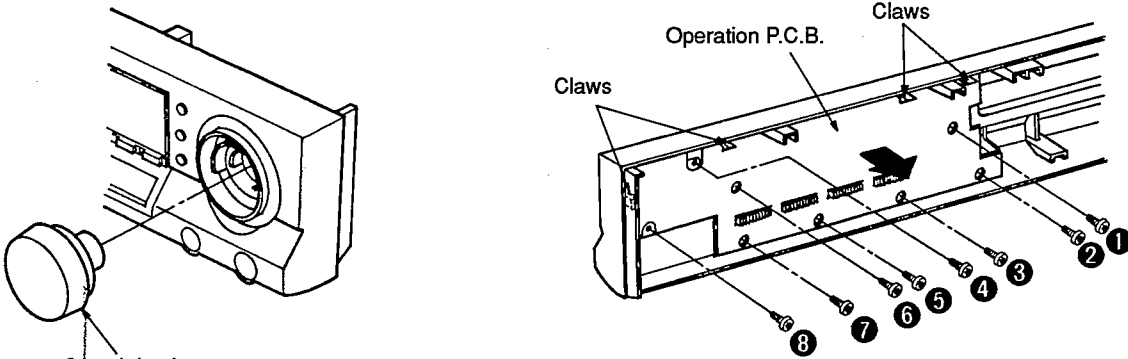
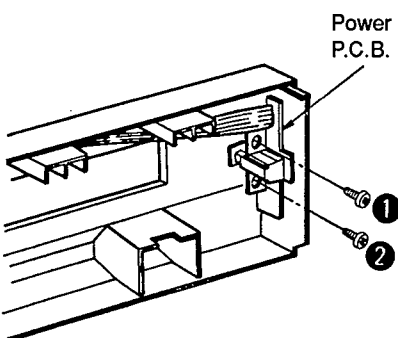
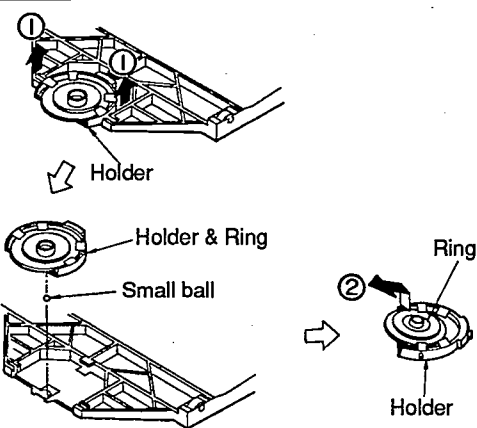
<p>Ref. No. 5</p>	<p>Removal of the headphones P.C.B.</p>	 <p>1. Pull out the headphones level knob.</p> <p>2. Remove the 1 screw (①).</p> <p>3. Remove the headphones holder.</p>	
<p>Procedure 1→2→5</p>			
<p>Ref. No. 6</p>	<p>Removal of the operation P.C.B.</p>	 <p>1. Pull out the search knob.</p> <p>2. Remove the 8 screws (①~⑧).</p> <p>3. Release the 4 claws.</p> <p>4. Remove the operation P.C.B. in the direction of arrow.</p>	
<p>Procedure 1→2→5→6</p>			
<p>Ref. No. 7</p>	<p>Removal of the power switch P.C.B.</p>	<p>Ref. No. 8</p>	<p>Removal of the holder and ring</p>
<p>Procedure 1→2→7</p>	 <p>● Remove the 2 screws (①, ②).</p>	<p>Procedure 1→3→8</p>  <p>1. Pull out the holder in the direction of arrow ①.</p> <p>2. Remove the ring in the direction of arrow ②.</p> <p>Caution: Be sure to handle the small ball carefully.</p>	

LONG SCAN

LONG SCAN

LONG SCAN

LONG SCAN

LONG SCAN

LONG SCAN

LONG SCAN

LONG SCAN

■ BLOCK DIAGRAM

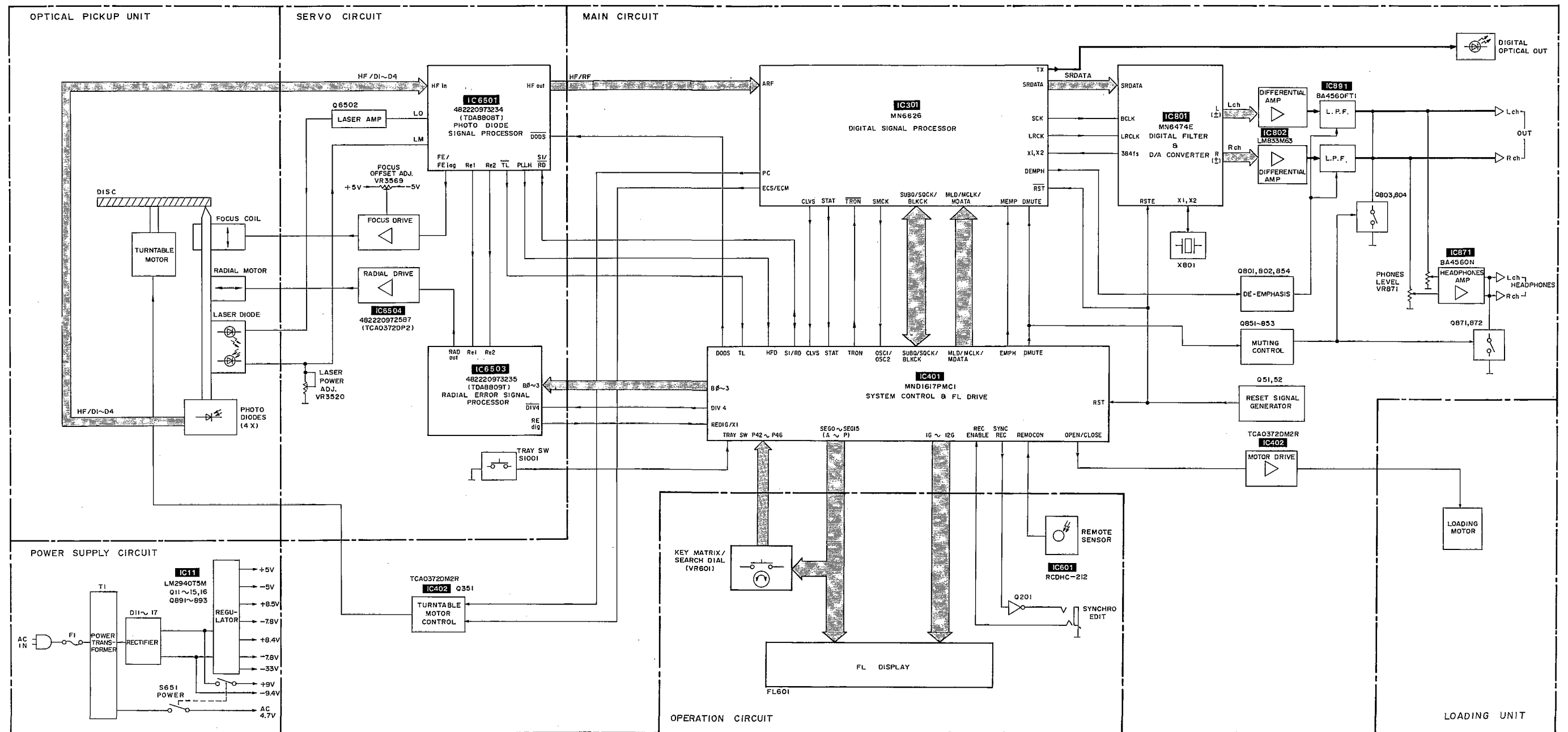

SCHEMATIC DIAGRAM

(Parts list on pages 36~39.)

(This schematic diagram may be modified at any time with development of new technology.)

Notes:

- S601~612 : Numeric (>10, 0, 1~10) switches.
 - S601: 0, S602: 1, S603: 2,
 - S604: 3, S605: 4, S606: 5,
 - S607: >10, S608: 10, S609: 9,
 - S610: 8, S611: 7, S612: 6
- S613 : Play (▶) PLAY switch.
- S614 : Skip (◀◀ SKIP) switch.
- S616 : Program (PROGRAM) switch.
- S617 : Disc link (DISC LINK) switch.
- S619 : Stop (■ STOP) switch.
- S620 : Skip (▶▶ SKIP) switch.
- S622 : Recall (RECALL) switch.
- S623 : Tape-side select (SIDE A/B) switch.
- S626 : Disc tray open/close (▲ OPEN/CLOSE) switch.
- S627 : Pause (⏸ PAUSE) switch.
- S628 : Repeat (REPEAT) switch.
- S629 : Clear (CLEAR) switch.
- S630 : Edit tape length (TAPE LENGTH) switch.
- S651 : Power "STANDBY ◻/ON" (POWER) switch in "on" position.

- S1001 : Tray (OPEN/CLOSE) switch.
- The voltage value and waveforms are the reference voltage of this unit measured by DC electronic voltmeter (high impedance) and oscilloscope on the basis of chassis. Accordingly, there may arise some error in voltage values and waveforms depending upon the internal impedance of the tester or the measuring unit.
- *The parenthesized are the values of voltage generated during playing (Test disc 1 kHz, L+R, 0 dB), others are voltage values in stop mode.

- Important safety notice: Components identified by Δ mark have special characteristics important for safety. When replacing any of these components, use only manufacturer's specified parts.
- The supply part number is described alone in the replacement parts list.

Part No.	Production Part No.	Supply Part No.
IC11	LM2940T5M	LM2940T5
IC891	BA4560FT1	SVIBA4560FT1

- ——— : Positive voltage lines.
- - - - - : Negative voltage lines.
- : Audio signal lines.

Caution!

- IC and LSI are sensitive to static electricity. Secondary trouble can be prevented by taking care during repair.
- Cover the parts boxes made of plastics with aluminum foil.
- Ground the soldering iron.
- Put a conductive mat on the work table.
- Do not touch the pins of IC or LSI with fingers directly.

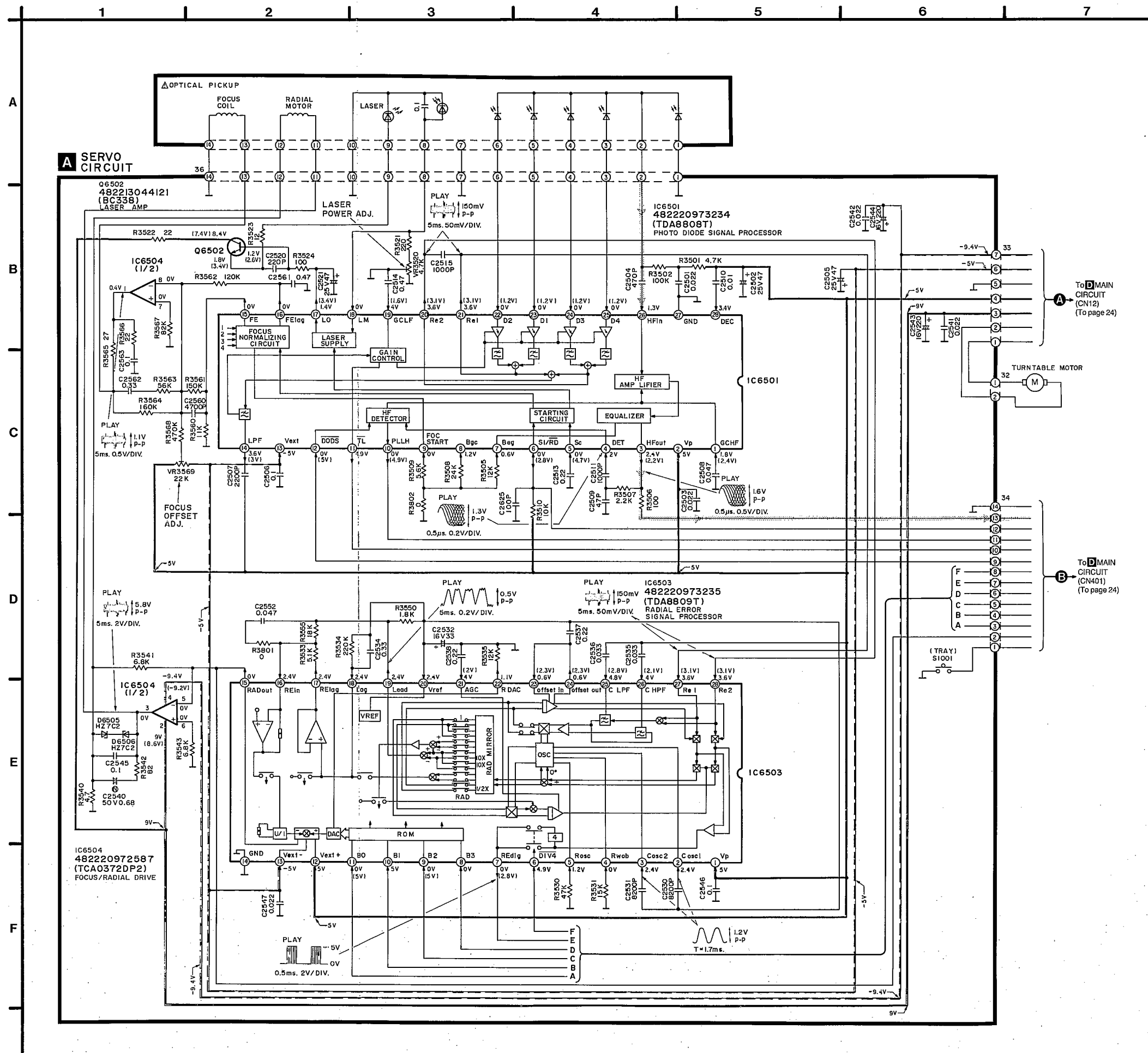

B OPERATION CIRCUIT

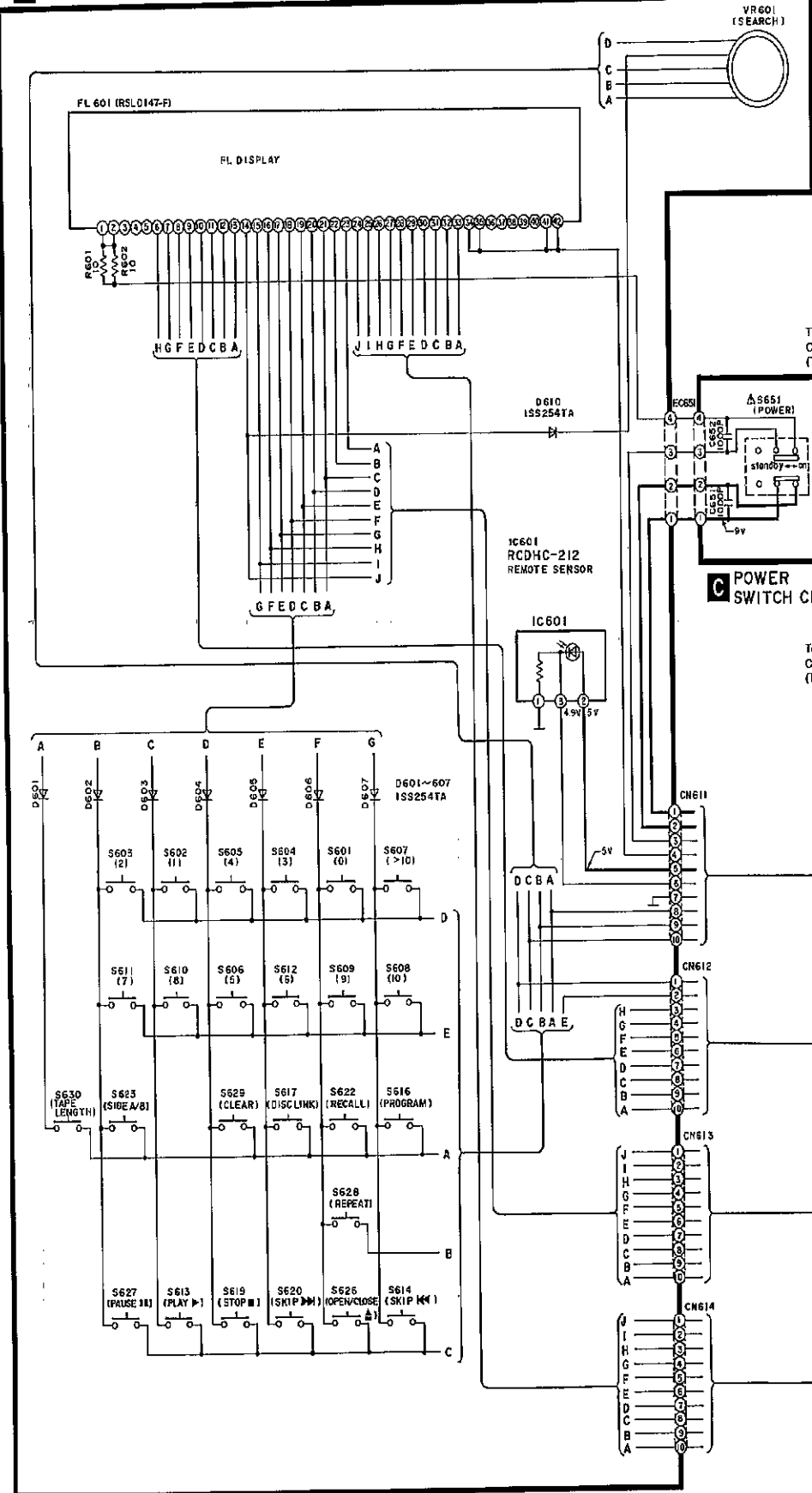

D MAIN CIRCUIT

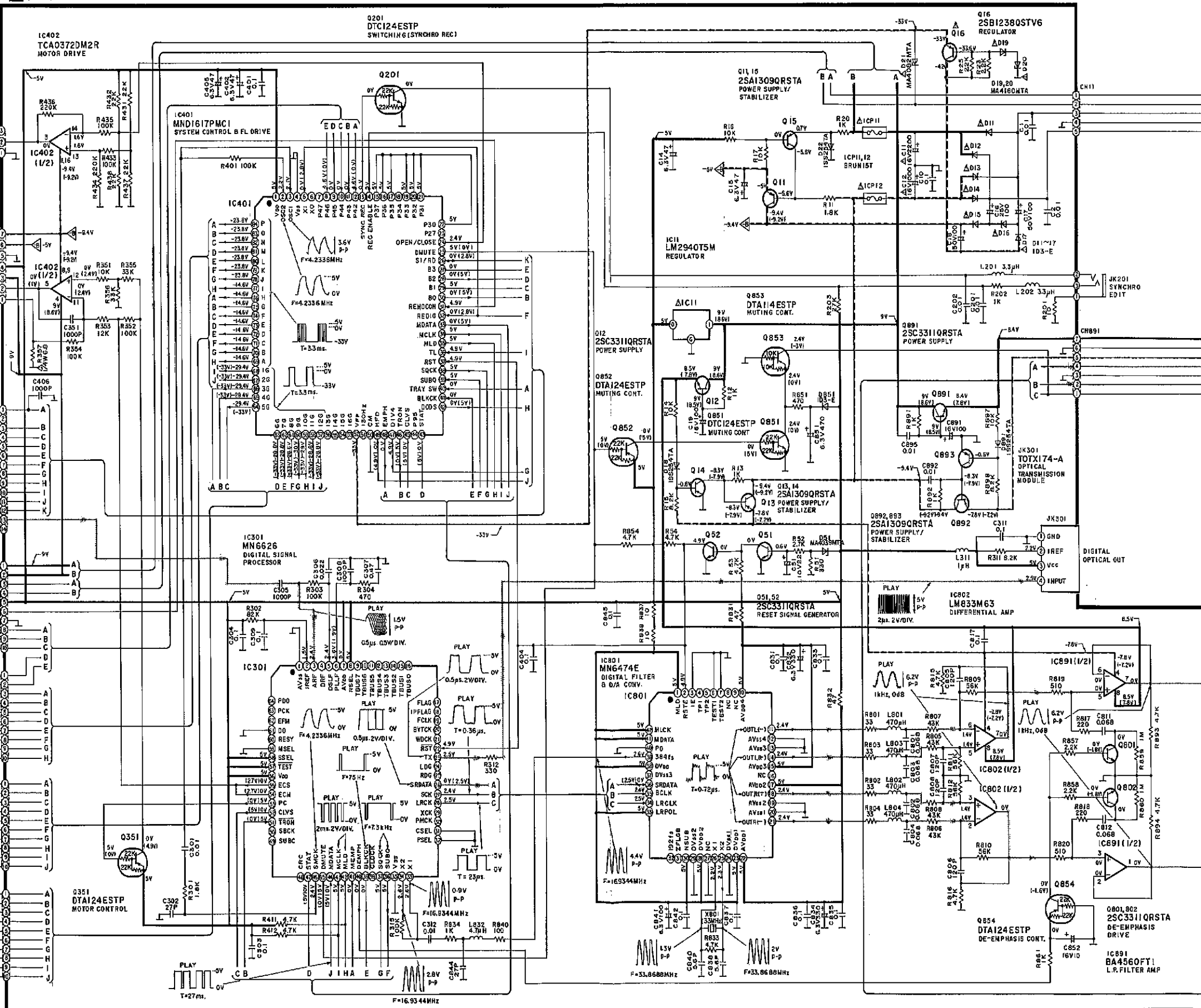

E POWER SUPPLY CIRCUIT

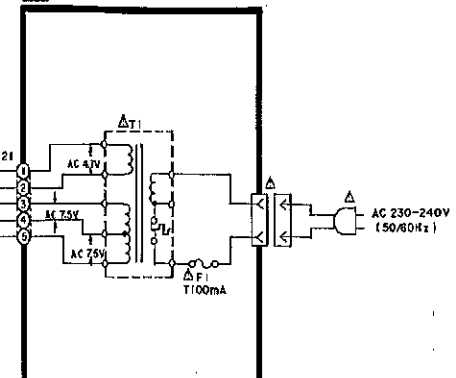

F HEADPHONES CIRCUIT

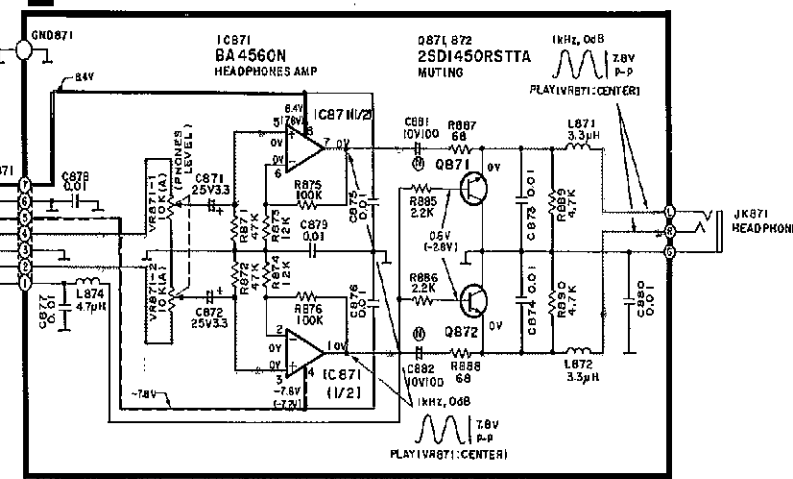

PRINTED CIRCUIT BOARD DIAGRAM

1 2 3 4 5 6 7 8 9 10 11 12 13 14 15 16 17 18 19

A SERVO P.C.B. (310 411 802 431)

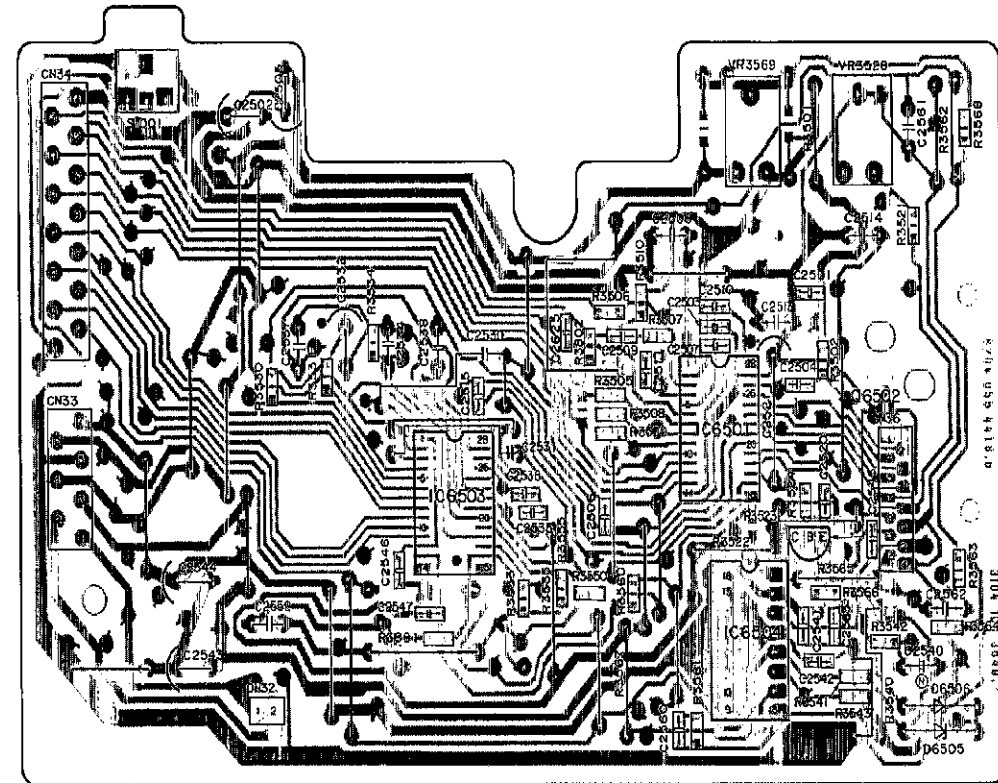

B OPERATION P.C.B. (REP1539A-S)

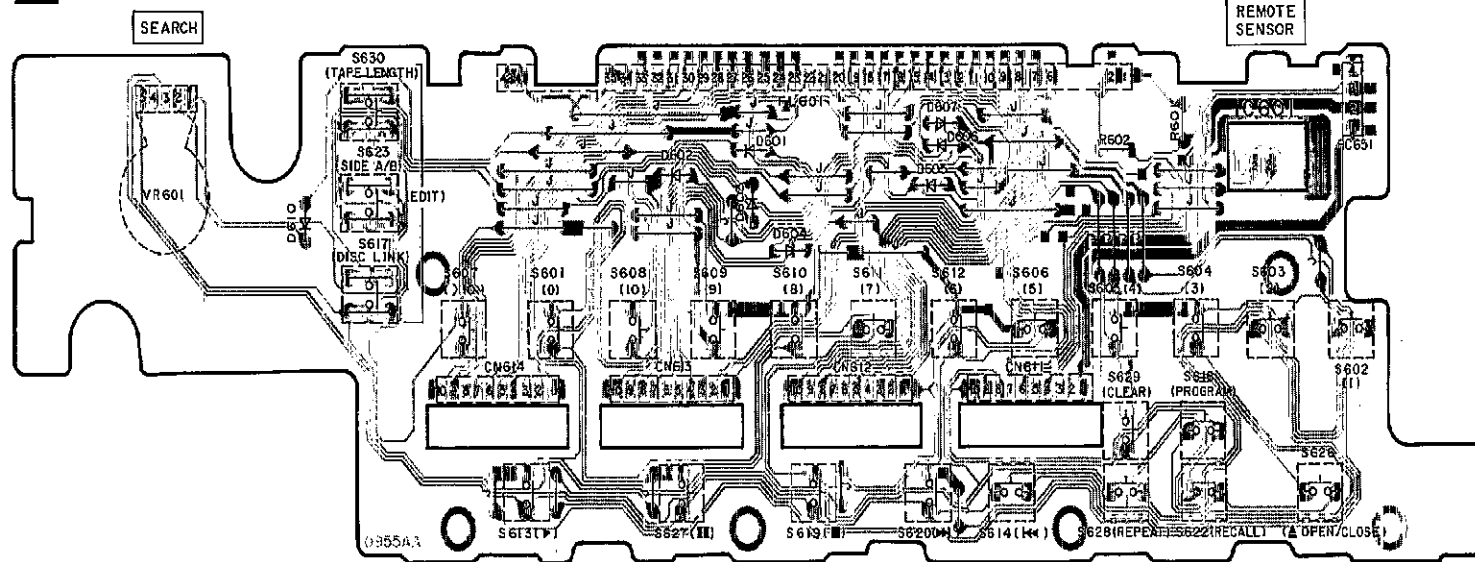

C POWER SWITCH P.C.B. (REP1539A-S)

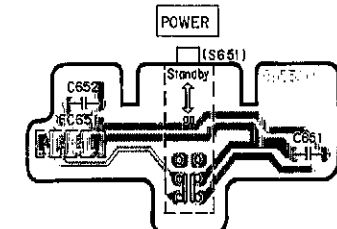

D MAIN P.C.B. (REP1532A-M)

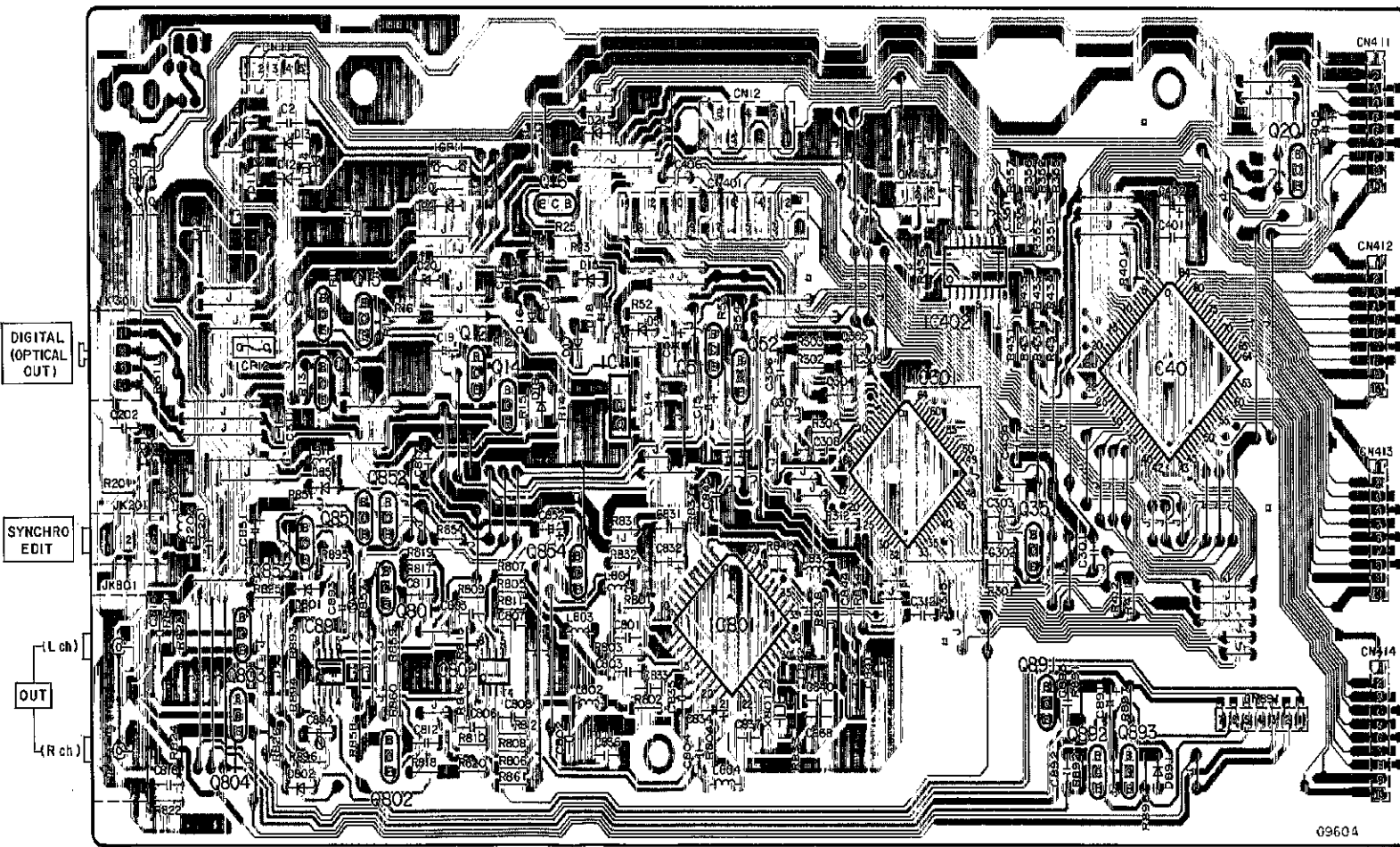

F HEADPHONES P.C.B. (REP1537A-S)

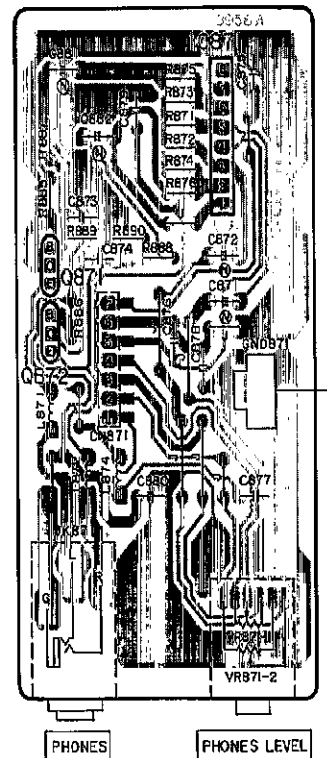

Terminal guide of IC's, transistors and diodes

BA4560FT1	No.1	LM833M63 8 Pin TCA0372DM2R 16 Pin	482220973234 (TDA8808T) 482220973235 (TDA8809T)
482220972587 (TCA0372DP2)	No.1	MN6474E 42 Pin MN6626 64 Pin MND1617PMC1 84 Pin	BA4560N LM2940T5M
RCDHC-212	2SA1309QRSTA 2SC3311QRSTA 2SD1450RSTTA	DTA114ESTP DTA124ESTP DTC124ESTP	2SB1238QSTV6
482213044121 (BC338)	1SS254TA 1D3-E	MA4039MTA MA4082MTA	MA4160MTA 482213081101 (HZ7C2)

E POWER SUPPLY P.C.B. (REP1536A-P)

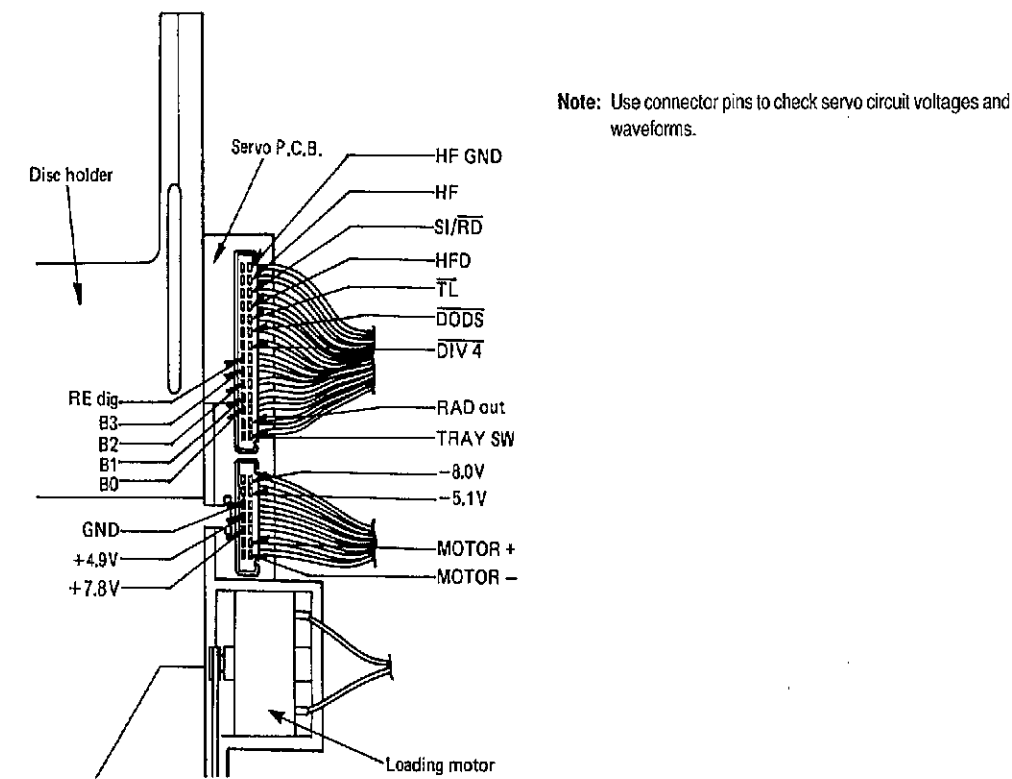
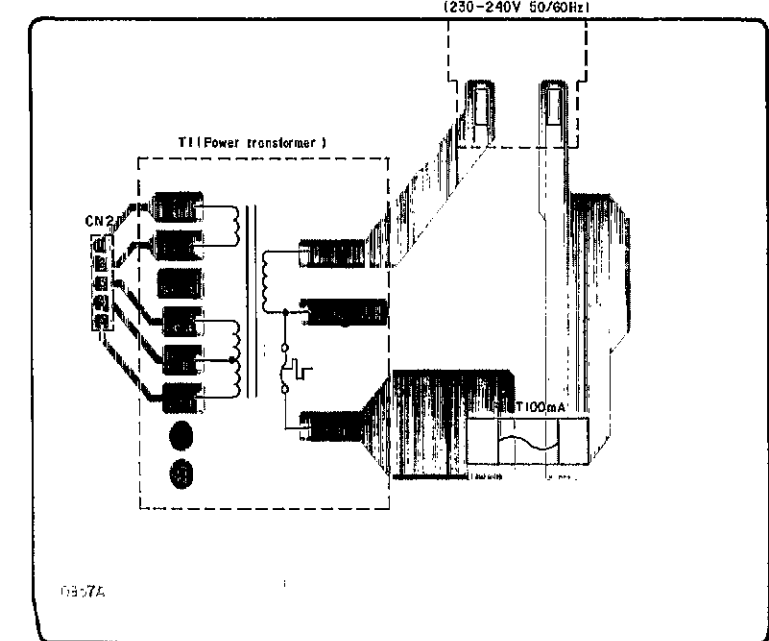

WIRING CONNECTION DIAGRAM

Notes:
BRN...Brown
BLK...Black

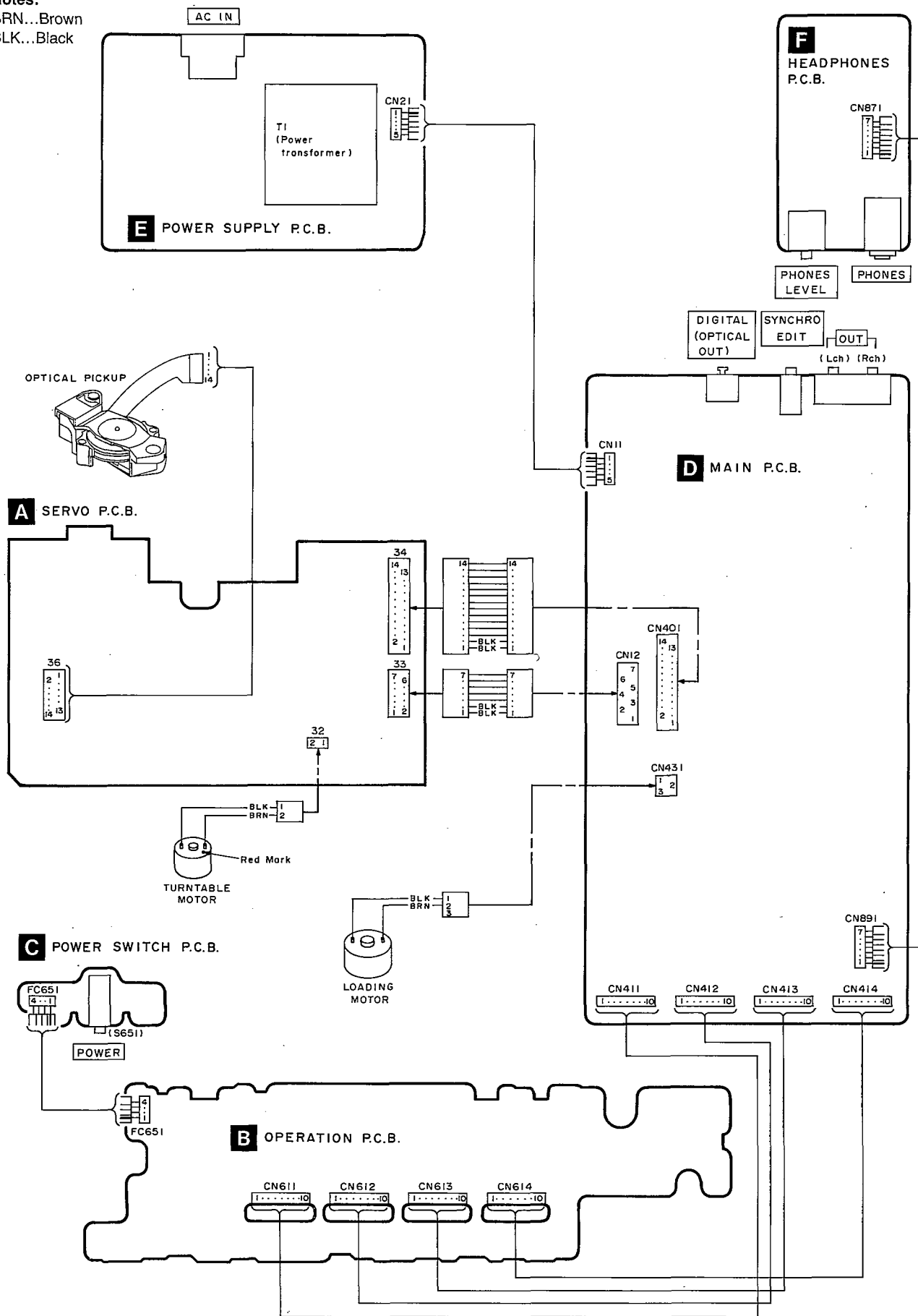

■ TERMINAL FUNCTION OF IC'S

• IC6501 (482220973234/TDA8808T): Photo diode signal processor

Pin No.	Mark	I/O Division	Function
1	GCHF	I	Gain control input of HF amplifier. Current output from HF amplitude detector
2	Vp	I	Positive supply voltage
3	HFout	O	HF amplifier and equalizer voltage output
4	DET	I	HF detector voltage input
5	Sc	I	Starting up capacitor input
6	Si/RD	I/O	On/off control (start input); ready signal output (starting up procedure successful)
7	Beg	I	Equalizer reference current input
8	Bgc	I	DC and LF gain control reference current input
9	FOC START	I	Focus normalizing circuit starting current
10	PLLH	O	PLL on hold output
11	TL	O	Track loss output
12	DODS	I	Drop out detector suppression input
13	Vext	I	Negative supply connection for FE and FEIag output stage; also substrate connection
14	LPF	O	Low pass filter for Iret, used in track loss (TL) detector and LF gain control

Pin No.	Mark	I/O Division	Function
15	FE	O	Current output of normalized, switched focus error signal
16	FEIag	O	Current output of switched focus error signal, intended for lag network
17	LO	O	Laser amplifier current output
18	LM	I	Laser monitor diode input
19	GCLF	I	Gain control input for AC and LF amplifiers. Current output from LF amplitude detector
20	Re2	O	Summation of amplified currents from D3 and D4
21	Re1	O	Summation of amplified currents from D1 and D2
22, 23	D1, D2	I	Current inputs to DC and LF photo diode amplifier
24, 25	D3, D4	I	Current inputs to DC and LF photo diode amplifier
26	HFin	I	Current input to HF amplifier
27	GND	—	Ground connection of device
28	DEC	I	Decoupling input (internal bypass)

• IC6503 (482220973235/TDA8809T): Radial error signal processor

Pin No.	Mark	I/O Division	Function
1	Vp	I	Positive supply voltage
2	Cosc1	I	Frequency setting capacitors for oscillator
3	Cosc2		
4	Rwob	I	Wobble generator input
5	Rosc	I	Biassing resistor for oscillator frequency and internal amplitude
6	DIV4	I	Radial error digital signal divided by four
7	REdig	O	Digital output of sign (Re2 - Re1)
8	B3	I	Input control bits for off-, catch-, play-status and DAC output current
9	B2		
10	B1		
11	B0		
12	Vext (+)	I	Positive external voltage input
13	Vext (-)	I	Negative external voltage input (also substrate connection)
14	GND	—	GND terminal
15	RADout	O	Current output of amplified (Re2 - Re1) input currents
16	REin	I	Radial error input
17	REIag	O	Voltage output of integrated (Re2 - Re1) input currents

Pin No.	Mark	I/O Division	Function
18	Lag	I	Connection of integrator capacitor for (Re1 - Re2) input currents
19	Lead	O	Lead output
20	Vref	I	Internal reference voltage output
21	AGC	I	Gain control input for radial error signal
22	RDAC	O	Biassing resistor for current output for track jumping (3 1/2 bits)
23	offset in	I	Offset control input for radial offset
24	offset off	O	Offset control output for radial offset
25	CLPF	I	Low-pass filter for Re1 and Re2, used for radial offset control
26	CHPF	I	High-pass filter for Re1 and Re2, used for radial offset control
27	Re1	I	Input for amplified currents from photo diodes D1 and D2
28	Re2	I	Input for amplified currents from photo diodes D3 and D4

• IC301 (MN6626): Digital signal processor

Pin No.	Mark	I/O Division	Function
1	AVSS	—	GND terminal
2	IREF	I	Reference current input
3	ARF	I	RF signal input
4	DRF	I	DSL bias terminal (Not used, open)
5	DSL F	I/O	DSL loop filter terminal
6	PLL F	I/O	PLL loop filter terminal
7	AVDD	I	Power supply terminal
8	RSEL	I	RF signal polarity setting terminal (Not used, connected to VDD)
9 16	TBUS7 TBUS0	O	Test terminal
17	FLAG	O	Flag terminal
18	IPFLAG	O	Interpolation flag terminal
19	FCLK	O	Crystal frame clock (Not used, open)
20	BYTCK	O	Byte clock (Not used, open)
21	WDCK	O	Word clock (Not used, open)
22	RST	I	Reset terminal
23	TX	O	Digital audio signal
24	LDG	O	Lch deglitch signal (Not used, open)
25	RDG	O	Rch deglitch signal (Not used, open)
26	SRDATA	O	Serial data output (MSB first)
27	SCK	O	Serial bit clock output
28	LRCK	O	L/R discriminating signal
29	XCK	O	Crystal OSC terminal (f=16.9344MHz) (Not used, open)
30	PMCK	O	Frequency division clock signal (Not used, open) $f = \frac{1}{192} \times CK = 88.2\text{kHz}$
31	CSEL	I	Test terminal (Connected to GND)
32	PSEL	I	Test terminal (Connected to GND)
33	X1	I	Crystal OSC terminal (f=16.9344MHz)
34	X2	O	Crystal OSC terminal (f=16.9344MHz)
35	VSS	—	GND terminal
36	SUBQ	O	Sub-code Q data
37	SQCK	I	Sub-code Q register clock
38	CLDCK	O	Sub-code frame clock (f=7.35kHz) (Not used, open)

Pin No.	Mark	I/O Division	Function
39	BLKCK	O	Sub-code block clock (f=75Hz)
40	DEMPH	O	De-emphasis ON signal ("H": ON)
41	MEMP	I	Emphasis signal
42	MLD	I	Command load signal ("L": LOAD)
43	MCLK	I	Command clock signal
44	M DATA	I	Command data signal
45	D MUTE	I	Muting input ("H": MUTE)
46	SMCK	O	System clock (f=4.2336MHz)
47	STAT	O	Status signal (CRC, CUE, CLVS, TTSTOP, FCLV, SQOK)
48	CRC	O	Sub-code CRC check terminal ("H": OK, "L": NG) (Not used, open)
49	SUBC	O	Sub-code serial output data (Not used, open)
50	SBCK	I	Sub-code serial output clock (Not used, open)
51	TRON	I	Tracking servo ON signal ("L": ON)
52	CLVS	O	Turntable servo phase synchro signal ("H": CLV, "L": Rough servo)
53	PC	O	Turntable motor ON signal ("L": ON)
54	ECM	O	Turntable motor drive signal (Forced mode)
55	ECS	O	Turntable motor drive signal (Servo error signal)
56	VDD	I	Power supply terminal
57	TEST	I	Test terminal (Normal: "H")
58	SSEL	I	"SUBQ" terminal mode select ("H": Q code buffer)
59	MSEL	I	"SMCK" terminal frequency select ("L": SMCK=4.2336MHz) (Not used, connected to GND)
60	RESY	O	Re-synchronizing signal of frame sync. (Not used, open)
61	DO	I	Drop-out detection signal ("H": Drop-out) (Not used, connected to GND)
62	EFM	O	EFM signal (Not used, open)
63	PCK	O	PLL extract clock (f=4.3218MHz) (Not used, open)
64	PDO	O	Phase compared signal of EFM and PCK (Not used, open)

• IC401 (MND1617PMC2): System control & FL drive

Pin No.	Mark	I/O Division	Function
1	VDD	I	Power supply terminal
2	OSC2	I	System clock input (f=4.2336MHz)
3	OSC1	I	
4	VSS	—	GND terminal
5	XI	I	Radial error digital signal
6	XO	O	Not Used, open
7	P47	I	
8 12	P46 P42	I	Key return signal
13	SYNC REC	O	Synchro rec control
14	REC ENABLE	I	
15 18	P37 P34	—	Not used, open and connected to terminal
19	P33	—	Not used, open and connected to terminal
20	P32		
21	P31		
22	P30		
23	P27		
24	OPEN/CLOSE	O	Loading motor control signal
25	DMUTE	O	Muting output ("H": MUTE)
26	SI/RD	I/O	On/off control and ready signal
27 30	B3 B0	O	Control bits for off-, catch-, play-status and DAC output current
31	REMOCON	I	Remote control signal
32	REDIG	I	Radial error digital signal
33	M DATA	O	Command data signal
34	MCLK	O	Command clock signal
35	MLD	O	Command load signal ("L": LOAD)

Pin No.	Mark	I/O Division	Function
36	TL	I	Track loss input
37	RST	I	Reset terminal
38	SQCK	O	Sub-code Q register clock
39	SUBQ	I	Sub-code Q data
40	TRAY SW	I	Disc holder open/close det. terminal
41	BLKCK	I	Sub-code block clock (f=75Hz)
42	DODS	O	Drop-out detect signal
43	STAT	I	Status signal (CRC, CUE, CLVS, TTSTOP, FCLV, SQOK)
44	P95	—	Not used, open
45	CLVS	I	Spindle servo phase synchro signal ("H": CLV, "L": Rough servo)
46	TRON	O	Tracking servo ON signal ("L": ON)
47	DIV4	O	Radial error digital signal divided by four
48	EMPH	O	Emphasis signal
49	HFD	I	PLL on hold input
50	CM	—	Not used, connected to GND
51	130Hz	—	Not used, open
52	VPP	I	Power supply terminal for FL drive
53 56	16G 13G	—	Not used, open
57 68	12G 1G	O	FL digit signal
69 84	A/SEGO P/SEGP	O	FL segment signal and key scan signal



REPLACEMENT PARTS LIST

●IC801 (MN6474E): Digital filter and D/A converter

Pin No.	Mark	I/O Division	Function	Pin No.	Mark	I/O Division	Function
1	MLD	I	Command load input (load: L) (Not used, connected to VDD)	24	DVSS1	—	GND terminal (digital system)
2	RSTE	I	Reset terminal	25	X2	O	Crystal OSC terminal (33MHz)
3	IE	I	Not used, connected to GND	26	X1	I	
4	TP1	—	TEST terminal	27	NC	—	Not connected
5	TP2	—		28	DVDD2	I	Power supply terminal
6	TEST1	I	TEST terminal 1 (connected to GND)	29	DVSS2	—	GND terminal (digital system)
7	TEST2	I	TEST terminal 2 (connected to GND)	30	NSUB	I	Sub-strate terminal (Not used, connected to VDD)
8	NC	—	Not connected	31	ZFLGB	O	Zero input detector terminal (Not used, open)
9	NC	—	Not connected	32	192fs	O	192fs (8.4672MHz) (Not used, open)
10	AVDD4	I	Power supply terminal	33	LRPOL	I	LR clock selector (Not used, connected to VDD)
11	OUTL (-)	O	Lch data output, (-) terminal	34	LRCLK	I	LR discrimination signal input
12	AVSS4	—	GND terminal	35	BCLK	I	Serial bit clock input
13	AVSS3	—	GND terminal	36	SRDATA	I	Serial data input (MSB first)
14	OUTL (+)	O	Lch data output, (+) terminal	37	DVSS3	—	GND terminal (digital system) (Not used, open)
15	AVDD3	I	Power supply terminal	38	DVDD	I	Power supply terminal
16	NC	—	Not connected	39	384fs	O	384fs (16.9344MHz) output
17	AVDD2	I	Power supply terminal	40	PD	I	Power down terminal (Not used, connected to GND)
18	OUTR (+)	O	Rch data output, (+) terminal	41	MDATA	I	Mode control data (Not used, connected to VDD)
19	AVSS2	—	GND terminal (analog system)	42	MCLK	I	Data clock for MDATA (not used, connected to VDD)
20	AVSS1	—	GND terminal (analog system)				
21	OUTR (-)	O	Rch data output, (-) terminal				
22	AVDD1	I	Power supply terminal				
23	DVDD1	I	Power supply terminal				

Notes: *Important safety notice:
 Components identified by Δ mark have special characteristics important for safety.
 Furthermore, special parts which have purposes of fire-retardant (resistors), high-quality sound (capacitors), low-noise (resistors), etc. are used.
 When replacing any of components, be sure to use only manufacturer's specified parts shown in the parts list.
 *The parenthesized indications in the Remarks columns specify the areas. (Refer to the cover page for area.)
 Parts without these indications can be used for all areas.
 *Remote Control Assy:
 Supply period for three years from termination of production.
 *MBJ Indicates in Remarks columns parts that are supplied by MBV.
 *Warning: This product uses a laser diode. Refer to caution statements on page 2.
 *ACHTUNG: Die Lasereinheit nicht zerlegen.
 Die Lasereinheit darf nur gegen eine vom Hersteller spezifizierte Einheit ausgetauscht werden.

Ref. No.	Part No.	Part Name & Description	Remarks	Ref. No.	Part No.	Part Name & Description	Remarks
		INTEGRATED CIRCUIT(S)		D601-607	1SS254TA	DIODE	
				D610	1SS254TA	DIODE	
				D801, 802	1SS254TA	DIODE	
				D851	1D3-E	DIODE	[MB]
				D891	1SS254TA	DIODE	
						VARIABLE RESISTOR(S)	
IC11	LM2940T5	I. C. REGULATOR	Δ	VR601	RSR4A002-H	V. R. SEARCH	[MB]
IC301	MN6626	I. C. D. SIGNAL PROCESSOR		VR871	EVJCB0F02A15	V. R. HEADPHONES	
IC401	MND1617PMC2	I. C. SYS CONTROL & FL DRIVE	[MB]			COIL	
IC402	TCA0372DM2R	I. C. MOTOR DRIVE					
IC601	RCRHC-212	I. C. REMOTE CONTROL RECEIVER	[MB]	L201, 202	RLQZN3R3KL-D	COIL	[MB]
IC801	MN6474E	I. C. FILTER & D/A CONV.		L311	RLQZN1R0KL-D	COIL	
IC802	LM833MG3	I. C. DIFFERENTIAL AMP.		L801-804	RLQZN471KL-D	COIL	[MB]
IC871	BA4560N	I. C. HEADPHONES AMP.		L832	RLQZN4R7KL-D	COIL	
IC891	SVIBA4560FT1	I. C. L. P. FILTER AMP.		L871, 872	RLQZN3R3KL-D	COIL	[MB]
				L874	RLQZN4R7KL-D	COIL	
		IC PROTECTOR(S)				TRANSFORMER	
ICP11, 12	SRUN15	I. C. PROTECTOR	Δ	T1	RTP1K4B015	POWER TRANSFORMER	Δ [MB]
						OSCILLATOR	
		TRANSISTOR(S)		X801	RSXA33M8J01T	OSCILLATOR (33MHz)	[MB]
Q11	2SA1309A-R	TRANSISTOR				DISPLAY TUBE	
Q12	2SC3311A-Q	TRANSISTOR		FL601	RSL0147-F	DISPLAY TUBE	[MB]
Q13, 14	2SA1309A-R	TRANSISTOR				SWITCH(ES)	
Q15	2SA1309A-R	TRANSISTOR		S601	EVQ21405R	SW, 0	
Q16	2SB1238QSTV6	TRANSISTOR	Δ	S602	EVQ21405R	SW, 1	
Q51, 52	2SC3311A-Q	TRANSISTOR		S603	EVQ21405R	SW, 2	
Q201	DTC124EST	TRANSISTOR		S604	EVQ21405R	SW, 3	
Q351	DTA124ESTP	TRANSISTOR		S605	EVQ21405R	SW, 4	
Q801, 802	2SC3311A-Q	TRANSISTOR		S606	EVQ21405R	SW, 5	
Q803, 804	2SD1450RTA	TRANSISTOR		S607	EVQ21405R	SW, >10	
Q851	DTC124EST	TRANSISTOR		S608	EVQ21405R	SW, 10	
Q852	DTA124ESTP	TRANSISTOR		S609	EVQ21405R	SW, 9	
Q853	DTA114ESTP	TRANSISTOR		S610	EVQ21405R	SW, 8	
Q854	DTA124ESTP	TRANSISTOR		S611	EVQ21405R	SW, 7	
Q871, 872	2SD1450RTA	TRANSISTOR					
Q891	2SC3311A-Q	TRANSISTOR					
Q892, 893	2SA1309A-R	TRANSISTOR					
		DIODE(S)					
D11-17	1D3-E	DIODE	Δ [MB]				
D18	1SS254TA	DIODE					
D19, 20	MA4160M	DIODE	Δ				
D21	MA4082MTA	DIODE	Δ				
D22	1SS254TA	DIODE					
D51	MA4039MTA	DIODE					

Ref. No.	Part No.	Part Name & Description	Remarks	Ref. No.	Part No.	Part Name & Description	Remarks
S612	EVQ21405R	SW, 6					
S613	EVQ21405R	SW, PLAY		Q6502	482213044121	TRANSISTOR	[MB]
S614	EVQ21405R	SW, R. SKIP					
S616	EVQ21405R	SW, PROGRAM				DIODE (S)	
S617	EVQ21405R	SW, DISC LINK					
S619	EVQ21405R	SW, STOP		D6505	482213030861	DIODE	[MB]
S620	EVQ21405R	SW, F. SKIP		D6506	482213030861	DIODE	[MB]
S622	EVQ21405R	SW, RECALL					
S623	EVQ21405R	SW, SIDE A/B				VARIABLE RESISTOR(S)	
S626	EVQ21405R	SW, OPEN/CLOSE					
S627	EVQ21405R	SW, PAUSE		VR3520	482210110685	V. R. LASER POWER ADJ.	[MB]
S628	EVQ21405R	SW, REPEAT		VR3569	482210011193	V. R. FOCUS OFFSET ADJ.	[MB]
S629	EVQ21405R	SW, CLEAR					
S630	EVQ21405R	SW, TAPE LENGTH				SWITCH	
S651	RSP2B010	SW, POWER	△				
		CONNECTOR (S)		S1001	482227612523	SW, TRAY	[MB]
CN11	RJS1A6605	SOCKET (5P)					
CN12	RJT001H007	SOCKET (7P)	[MB]				
CN21	RJS1A6605	SOCKET (5P)					
CN401	RJT001H014	SOCKET (14P)	[MB]				
CN411-414	RJU003K010M1	SOCKET (10P)					
CN431	RJT001H003	SOCKET (3P)	[MB]				
CN611-614	RJT003K010M1	CONNECTOR (10P)					
CN871	RJS1A6607T1	SOCKET (7P)	[MB]				
CN891	RJS1A6607T1	SOCKET (7P)	[MB]				
FC651	RWJ1804200XX	FLAT CABLE (4P)					
		TERMINAL					
GND871	RMCO184	TERMINAL, GND	[MB]				
		JACK (S)					
JK201	RJ333T01	JACK, SYNCHRO EDIT					
JK301	TOTX174-A	JACK, OPTICAL OUT					
JK801	RJH3201N	JACK, LINE OUT					
JK871	QJA0455ZC	JACK, HEADPHONES					
		FUSE					
F1	XBA2C01T80	FUSE 250V T100mA	△				
		<SERVO P. C. B. >					
		INTEGRATED CIRCUIT(S)					
IC6501	482220973234	I. C, PHOTO DIODE S. P.	[MB]				
IC6503	482220973235	I. C, RADIAL ERROR S. P.	[MB]				
IC6504	482220972587	I. C, FOCUS/RADIAL DRIVE	[MB]				
		TRANSISTOR(S)					

Notes : * Capacity values are in microfarads (uF) unless specified otherwise, P=Pico-farads (pF) F=Farads (F)
* Resistance values are in ohms, unless specified otherwise, 1K=1,000 (OHM) , 1M=1,000k (OHM)

Ref. No.	Part No.	Values & Remarks	Ref. No.	Part No.	Values & Remarks	Ref. No.	Part No.	Values & Remarks
			R833	ERDS2TJ472	1/4W 4.7K	C651, 652	ECBT1H102KB5	50V 1000P
		RESISTORS	R834	ERDS2TJ102	1/4W 1K	C801-804	ECQV1H683JM3	50V 0.068U
			R837, 838	ERDS2TJ100	1/4W 10	C805-808	ECBT1H121KB5	50V 120P
R11	ERDS2TJ182	1/4W 1.8K	R840	ERDS2TJ101	1/4W 100	C811, 812	ECQV1H683JM3	50V 0.068U
R12, 13	ERDS2TJ102	1/4W 1K	R851	ERDS2TJ471	1/4W 470	C815, 816	ECBT1H102KB5	50V 1000P
R14	ERDS2TJ103	1/4W 10K	R854	ERDS2TJ472	1/4W 4.7K	C817	ECFR1E1042F5	25V 0.1U
R15	ERDS2TJ822	1/4W 8.2K	R857, 858	ERDS2TJ222	1/4W 2.2K	C831	ECFR1E1042F5	25V 0.1U
R16, 17	ERDS2TJ103	1/4W 10K	R859, 860	ERDS2TJ105T	1/4W 1M	C832	ECEAOJU331B	6.3V 330U
R20	ERDS2TJ102	1/4W 1K	R861	ERDS2TJ102	1/4W 1K	C833	ECFR1E1042F5	25V 0.1U
R23	ERDS2TJ222	1/4W 2.2K	R871, 872	ERDS2TJ473	1/4W 47K	C834	ECEAOJU331B	6.3V 330U
R25	ERDS2TJ222	1/4W 2.2K	R873, 874	ERDS2TJ123	1/4W 12K	C835-837	ECFR1E1042F5	25V 0.1U
R51	ERDS2TJ331	1/4W 330	R875, 876	ERDS2TJ104	1/4W 100K	C838	ECBT1H566K5	50V 5.6P
R52	ERDS2TJ272T	1/4W 2.7K	R885, 886	ERDS2TJ222	1/4W 2.2K	C840	ECBT1H566K5	50V 5.6P
R53, 54	ERDS2TJ472	1/4W 4.7K	R887, 888	ERDS2TJ680T	1/4W 68	C841	ECEAOJKA101B	6.3V 100U
R201	ERDS2TJ100	1/4W 10	R889, 890	ERDS2TJ472	1/4W 4.7K	C842	ECFR1E1042F5	25V 0.1U
R202	ERDS2TJ102	1/4W 1K	R891, 892	ERDS2TJ102	1/4W 1K	C844	ECBT1H270J5	50V 27P
R203	ERDS2TJ273	1/4W 27K	R893, 894	ERDS2TJ472	1/4W 4.7K	C845	ECFR1E1042F5	25V 0.1U
R301	ERDS2TJ182	1/4W 1.8K	R895, 896	ERDS2TJ471	1/4W 470	C851	ECEAOJU471	6.3V 470U
R302	ERDS2TJ823T	1/4W 82K	R897	ERDS2TJ103	1/4W 10K	C852	ECEA1CKA100B	16V 10U
R303	ERDS2TJ104	1/4W 100K	R898	ERDS2TJ822	1/4W 8.2K	C871, 872	ECEA1EKN3R3B	25V 3.3U
R304	ERDS2TJ471	1/4W 470				C873, 874	ECQB1H103JF3	50V 0.01U
R311	ERDS2TJ822	1/4W 8.2K			CAPACITORS	C875-880	ECBT1C103NS5	16V 0.01U
R312	ERDS2TJ331	1/4W 330				C881, 882	ECEA1AN101XB	10V 100U
R315	ERDS2TJ104	1/4W 100K	C1, 2	ECFTD103KXL	50V 0.01U	C891	ECEA1CKA101B	16V 100U
R351	ERDS2TJ103	1/4W 10K	C10	ECFR1E1042F5	25V 0.1U	C892	ECBT1C103NS5	16V 0.01U
R352	ERDS2TJ104	1/4W 100K	C11	ECA1CM222B	16V 2200U △	C893, 894	ECEA1CKN220B	16V 22U
R353	ERDS2TJ123	1/4W 12K	C12	ECEA1CU102	16V 1000U △	C895	ECBT1C103NS5	16V 0.01U
R354	ERDS2TJ104	1/4W 100K	C14, 15	ECEAOJKA470B	6.3V 47U			
R355, 356	ERDS2TJ333	1/4W 33K	C16	ECEA1EU101	25V 100U			<SERVO P. C. B. >
R357	ERD25FJ6R8	1/4W 6.8 △	C17, 18	ECEA1HJ101	50V 100U			RESISTORS
R401	ERDS2TJ104	1/4W 100K	C19	ECEA1CKA101B	16V 100U			
R411, 412	ERDS2TJ472	1/4W 4.7K	C51	ECEA1AKA220B	10V 22U	R3501	482205024702	1/8W 4.7K [MB]
R431, 432	ERDS2TJ223	1/4W 22K	C201, 202	ECBT1C103NS5	16V 0.01U	R3502	482205110104	1/8W 100K [MB]
R433	ERDS2TJ104	1/4W 100K	C301	ECBT1C103NS5	16V 0.01U	R3505	482205110123	1/4W 12K [MB]
R434	ERDS2TJ224T	1/4W 220K	C302	ECBT1H270J5	50V 27P	R3506	482205110101	1/8W 100 [MB]
R435	ERDS2TJ104	1/4W 100K	C303, 304	ECFR1E1042F5	25V 0.1U	R3507	482205120222	1/8W 2.2K [MB]
R436	ERDS2TJ224T	1/4W 220K	C305	ECBT1H102KB5	50V 1000P	R3508	482205110243	1/4W 24K [MB]
R437, 438	ERDS2TJ223	1/4W 22K	C306	ECFR1E223KB	25V 0.022U	R3509	482205110562	1/8W 5.6K [MB]
R601, 602	ERDS2TJ100	1/4W 10	C307	ECQV1H474JM3	50V 0.47U	R3510	482205110103	1/8W 10K [MB]
R801-804	ERDS2TJ330	1/4W 33	C308	ECBT1H102KB5	50V 1000P	R3521	482205110221	1/8W 220 [MB]
R805-808	ERDS2TJ433	1/4W 43K	C309	ECFR1E1042F5	25V 0.1U	R3522	482205210229	1/3W 22 [MB]
R809-812	ERDS2TJ563	1/4W 56K	C311	ECFR1E1042F5	25V 0.1U	R3523	482205210129	1/3W 12 [MB]
R815, 816	ERDS2TJ472	1/4W 4.7K	C312	ECBT1C103NS5	16V 0.01U	R3524	482205110101	1/8W 100 [MB]
R817, 818	ERDS2TJ221	1/4W 220	C351	ECBT1H102KB5	50V 1000P	R3530	482205110473	1/4W 47K [MB]
R819, 820	ERDS2TJ511	1/4W 510	C401	ECFR1E1042F5	25V 0.1U	R3531	482205110153	1/4W 15K [MB]
R821, 822	ERDS2TJ473	1/4W 47K	C402	ECEAOJKA470B	6.3V 47U	R3533	482205110152	1/4W 5.1K [MB]
R823, 824	ERDS2TJ331	1/4W 330	C404	ECFR1E1042F5	25V 0.1U	R3534	482205110224	1/8W 220K [MB]
R825, 826	ERDS2TJ102	1/4W 1K	C405	ECEAOJKA470B	6.3V 47U	R3535	482205021203	3/5W 12K [MB]
R831, 832	ERDS2TJ470	1/4W 47	C406	ECBT1H102KB5	50V 1000P	R3540	482205024708	3/5W 4.7 [MB]

Ref. No.	Part No.	Values & Remarks
R3541	482205110682	1/4W 6.8K [MB]
R3542	482205110829	1/8W 82 [MB]
R3543	482205110682	1/8W 6.8K [MB]
R3550	482205110182	1/4W 1.8K [MB]
R3555	482205110183	1/4W 18K [MB]
R3560	482211191494	1/8W 11K [MB]
R3561	482205110154	1/4W 150K [MB]
R3562	482205021204	3/5W 120K [MB]
R3563	482205110563	1/8W 56K [MB]
R3564	482211191495	1/8W 160K [MB]
R3565	482205210279	1/3W 27 [MB]
R3566	482205110229	1/8W 22 [MB]
R3567	482205028203	1/8W 82K [MB]
R3568	482205110474	1/4W 470K [MB]

Ref. No.	Part No.	Values & Remarks
C2546	482212233496	63V 0.1U [MB]
C2547	482212232863	50V 0.022U [MB]
C2552	482212143526	100V 0.047U [MB]
C2560	482212231784	50V 4700P [MB]
C2561	482212151252	63V 0.47U [MB]
C2562	532212142661	63V 0.33U [MB]
C2563	482212233496	63V 0.1U [MB]
C2625	482212231765	50V 100P [MB]

Ref. No.	Part No.	Values & Remarks
CHIP JUMPER(S)		
R3801	482205110008	JUMPER [MB]
R3802	482205110008	JUMPER [MB]
CAPACITORS		

C2501	482212232863	50V 0.022U [MB]
C2502	482212440433	25V 47U [MB]
C2503	482212232863	50V 0.022U [MB]
C2504	482212231727	63V 470P [MB]
C2505	482212440433	25V 47U [MB]
C2506	482212233496	63V 0.1U [MB]
C2507	482212231644	63V 2200P [MB]
C2508	532212142491	100V 0.047U [MB]
C2509	482212231772	50V 47P [MB]
C2510	482212232442	50V 0.01U [MB]
C2511	482212231746	50V 1000P [MB]
C2513	482212143375	63V 0.22U [MB]
C2514	482212151252	63V 0.47U [MB]
C2515	482212231746	50V 1000P [MB]
C2520	482212231965	63V 220P [MB]
C2521	482212422027	25V 47U [MB]
C2530	482212151321	63V 8200P [MB]
C2531	482212151321	63V 8200P [MB]
C2532	482212440272	16V 33U [MB]
C2534	532212142661	63V 0.33U [MB]
C2535	482212231981	50V 0.033U [MB]
C2536	482212231981	50V 0.033U [MB]
C2537	482212143375	63V 0.22U [MB]
C2538	482212143375	63V 0.22U [MB]
C2540	482212441583	50V 0.68U [MB]
C2541	482212232863	50V 0.022U [MB]
C2542	482212232863	50V 0.022U [MB]
C2543	482212440196	16V 220U [MB]
C2544	482212440196	16V 220U [MB]
C2545	482212233496	63V 0.1U [MB]

■ PACKAGING

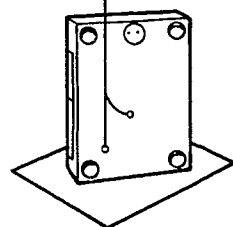
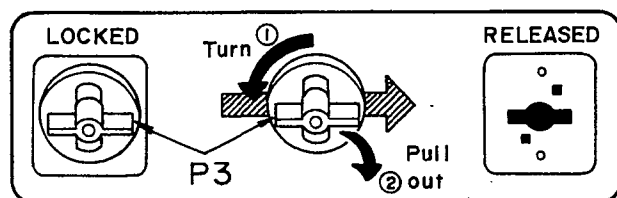
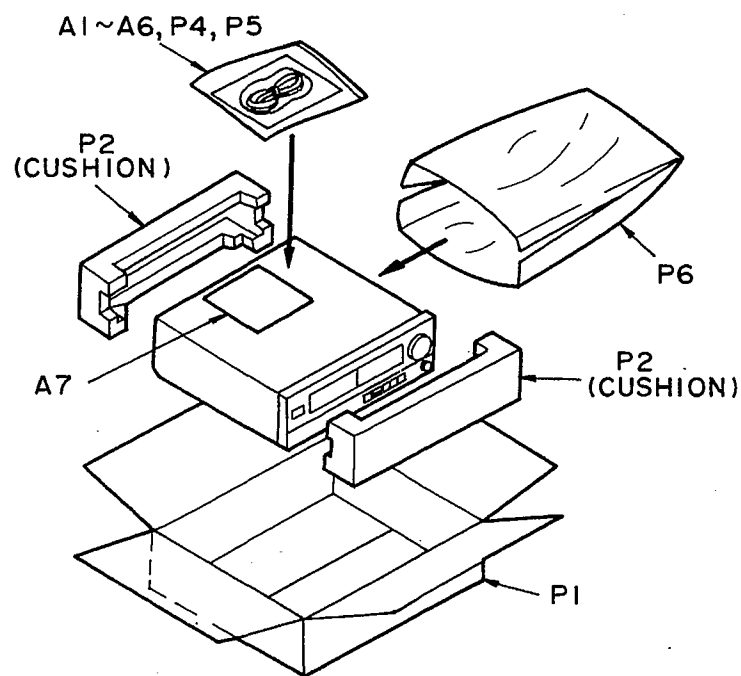

Ref. No.	Part No.	Part Name & Description	Remarks
CABINET PARTS			
1	RKMO098-K	CABINET	[MB]
2	SNE2129-1	SCREW	
3	XTBS3+8JFZ1	SCREW	
4	RFKHLPG540AE	REAR PANEL ASS'Y	(E/EG) [MB]
4	RFKHLPG540AB	REAR PANEL ASS'Y	(EB) [MB]
5	EYF52BC	FUSE HOLDER	
6	RGK0499-K	TRAY LID	[MB]
7	RKAO040B	FOOT	[MB]
8	RMK0178	BOTTOM BOARD	[MB]
9	RMR0020	SPACER (A)	[MB]
10	RMR0021	SPACER (B)	[MB]
11	RMR0377	PCB SUPPORT	[MB]
12	RMR0573-K1	SPACER (C)	[MB]
13	RWJ6405130XX	FLAT CABLE (5P)	[MB]
14	RMR0659-K	FL. HOLDER	[MB]
15	RGU0030	BUTTON, POWER	
16	RGW0048	KNOB, H. P. VOLUME	
17	RMR0610-K	H. P. PCB HOLDER	[MB]
18	RWJ1807100XX	FLATE CABLE (7P)	[MB]
19	XTB3+20JFZ	SCREW	
20	XTB3+35JFZ	SCREW	
21	REX0285	FLAT CABLE (14P)	[MB]
22	XTB3+8JFZ	SCREW	
23	RGW0169-K	SEARCH DIAL	[MB]
24	RYPD401Z-K	FRONT PANEL ASS'Y	[MB]
24-1	RGU0807-K	BUTTON, PLAY etc.	[MB]
24-2	RGU0810-K	BUTTON, DISC LINK etc.	[MB]
24-3	RKWD245A-R	FL. PANEL	[MB]
25	XTBS26+8J	SCREW	
27	REX0007	FLAT CABLE (7P)	[MB]
28	SJS9236	AC INLET	△
LOADING UNIT PARTS			
101	482244450603	DISC HOLDER	[MB]
102	482232550176	GROMMET, CABLE	[MB]
103	482232550177	GROMMET, CABLE	[MB]
104	482246692251	DISC TRAY	[MB]
106	482235810115	DRIVE BELT	[MB]
107	482252232359	WHEEL, GEAR	[MB]
108	482253251518	RING, RUBBER	[MB]
109	482240261081	GUIDE	[MB]
111	482240261132	GUIDE	[MB]
112	482252890638	ROLLER	[MB]
113	482249251902	SPRING, COMPRES.	[MB]
114	482246661587	FOAM	[MB]
116	482240261107	LEVER	[MB]
117	482249263659	SPRING, BLADE	[MB]
118	482244460568	DISC LID	[MB]

Ref. No.	Part No.	Part Name & Description	Remarks
119	482249232883	SPRING, TENSION	[MB]
121	482252890639	ROLLER	[MB]
122	482246692257	PLATE	[MB]
123	482240261207	HOLDER	[MB]
124	482252040177	SMALL BALL	[MB]
126	482253080503	RING, PRESSURE	[MB]
127	482269130209	OPTICAL PICKUP UNIT	[MB]
128	482240261196	SUPPORT	[MB]
129	482249263746	CLAMPING SPRING	[MB]
131	482236120998	LOADING MOTOR	[MB]
132	482240250244	BRACKET	[MB]
133	482249251935	SPRING, COMPRES.	[MB]
134	482270112729	CHASSIS	[MB]
PACKING MATERIALS			
P1	RPG1375	PACKING CASE	[MB]
P2	RPN0647	CUSHION	[MB]
P3	RMR0024	LOCK SHAFT	[MB]
P4	XZB26X17C03	PROTECTION BAG (TRANSMITT)	
P5	XZB23X35C03	PROTECTION BAG (F. B.)	
P6	XZB60X65A01Z	PROTECTION BAG	
ACCESSORIES			
A1	EUR642100	REMOTE CONTROL TRANSMITTER	[MB]
A1-1	UR64EC1326	BATTERY COVER	[MB]
A2	RJA0018-1K	AC POWER SUPPLY CORD	△ (E/EG)
A2	VJA0733	AC POWER SUPPLY CORD	△ (EB)
A3	ROA0013	WARRANTY CARD	
A4	RQCB0169	SERVICE CENTER LIST	
A5	RFKSLPG540AE	INSTRUCTIONS MANUAL	(E) [MB]
A5	RQT1677-B	INSTRUCTIONS MANUAL	(EB) [MB]
A5	RFKSLPG540AG	INSTRUCTIONS MANUAL	(EG) [MB]
A6	SJP2249-3	STEREO CONNECTION CABLE	
A7	RQCA0059	LOCK CAUTION SHEET	[MB]

CABINET PARTS LOCATION

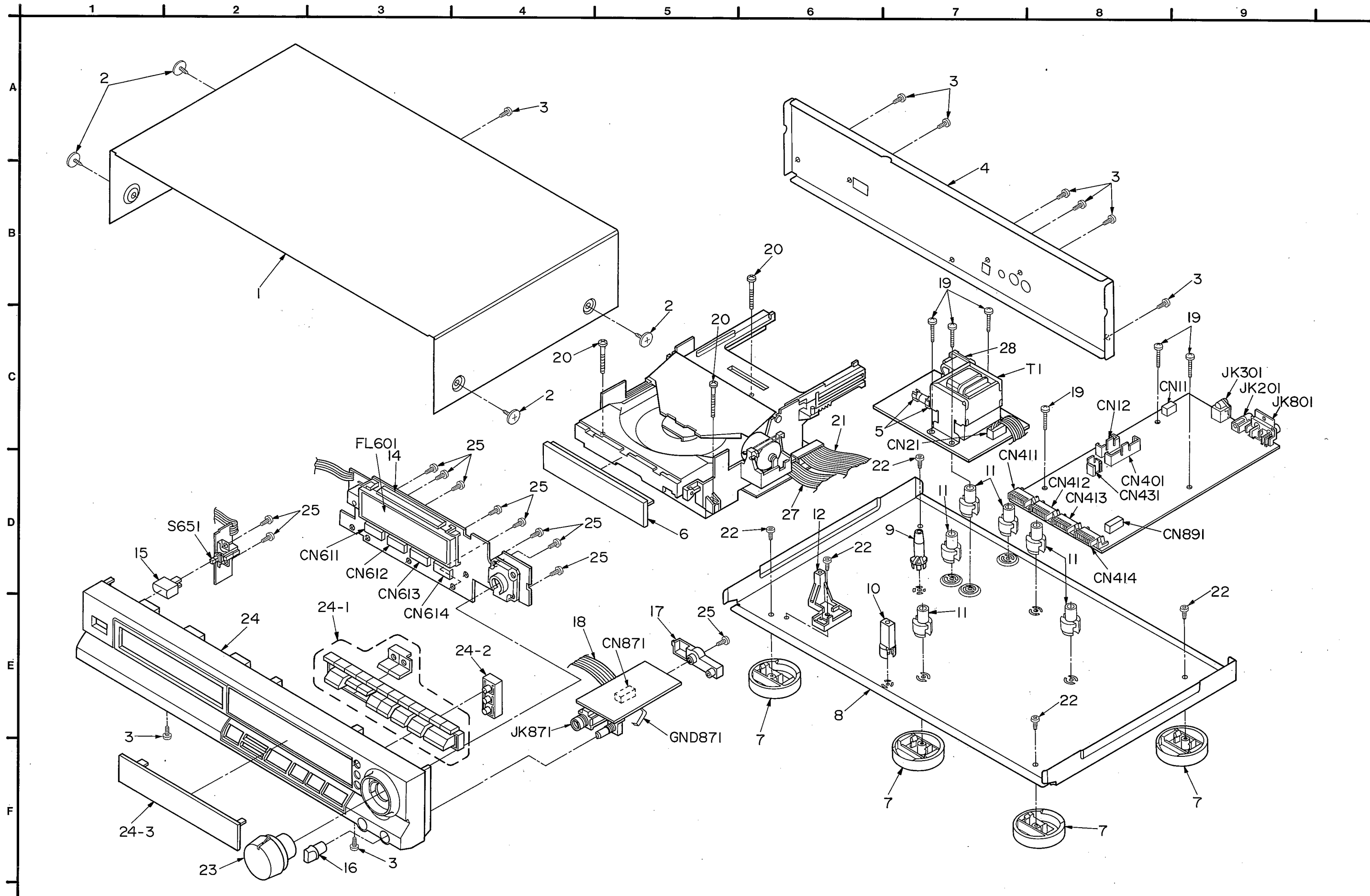

LOADING UNIT PARTS LOCATION

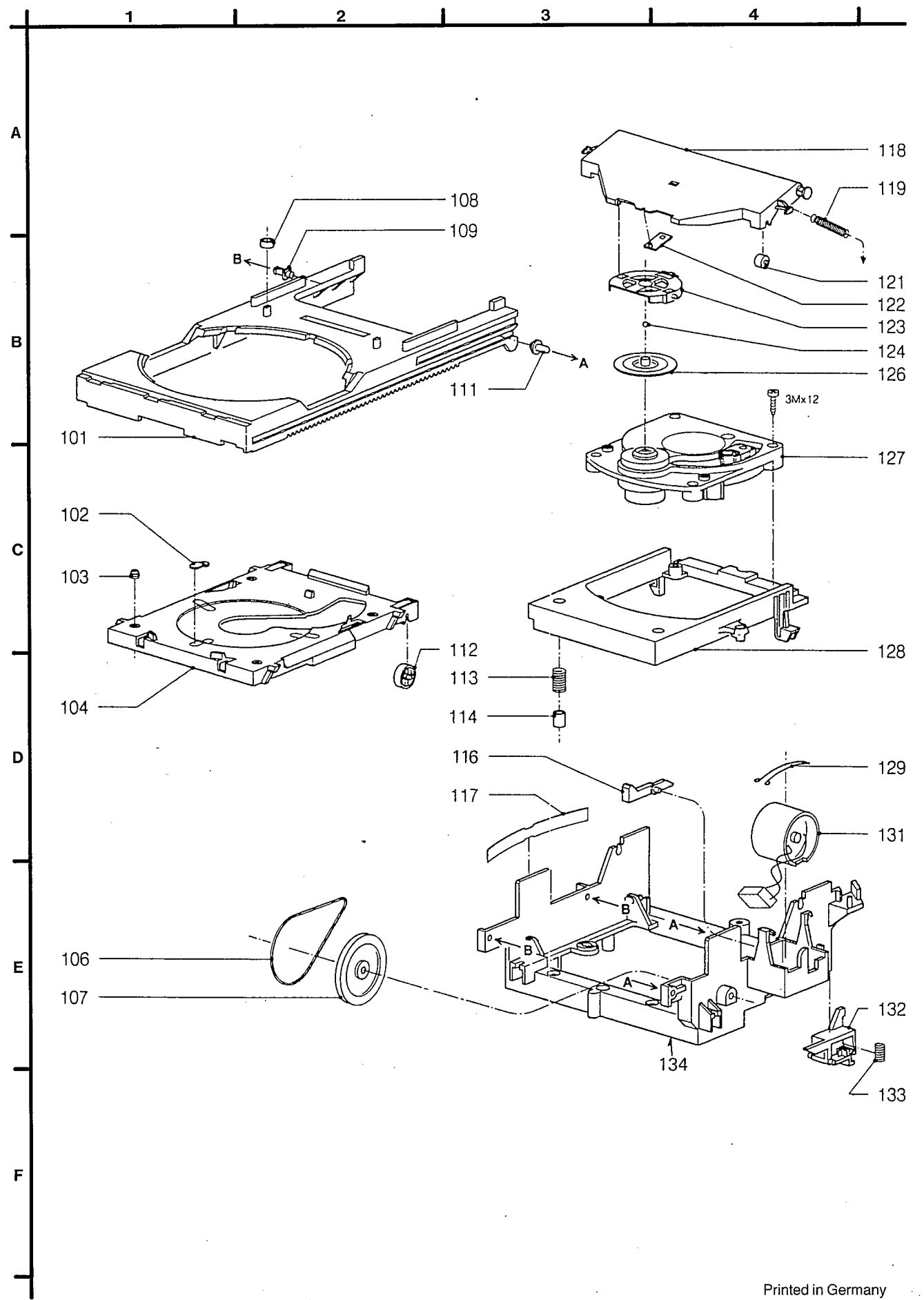

1489