

# Service Manual

COMPACT  
**disc**  
DIGITAL AUDIO

DIGITAL

MASH\*  
multi-stage noise shaping

Compact Disc Player

## SL-PS740A

Colour

(K) ..... Black Type

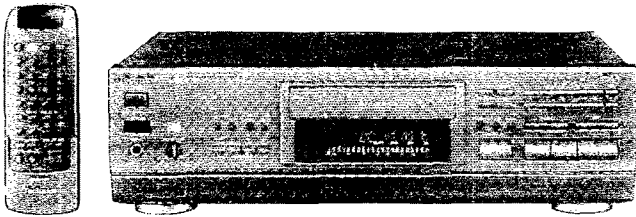

### Areas

Suffix for Model No.	Area	Colour
(E)	Europe	(K)
(EB)	Great Britain	
(EG)	Germany and Italy	

- \*  
 •Technics (or Panasonic) developed the world's first MASH type DAC and ADC. MASH technology was invented by NTT (LSI Labs).  
 •MASH is a trademark of NTT.

## SL-PG320A TRAVERSE DECK SERIES (RAD0301-1) SPECIFICATIONS

### ■ Audio

No. of channels	2 (left and right, stereo)
Frequency response	2-20,000 Hz, $\pm 0.3$ dB
Output voltage	2 V (at 0 dB)
Dynamic range	100 dB
S/N	115 dB
Harmonic distortion	0.0018% (1 kHz, 0 dB)
Total harmonic distortion	0.0023% (1 kHz, 0 dB)
Wow and flutter	Below measurable limit
DA converter	MASH (1 bit)
Output impedance	600 $\Omega$
Load impedance	More than 10 k $\Omega$
Headphone output level	15 mW max. 32 $\Omega$ (adjustable)

### ■ Pickup

Wavelength	780 nm
Laser Power	No hazardous radiation is emitted (with safety protection)

### ■ General

Power consumption	10 W
Power supply	AC 50/60 Hz, 230-240 V
Dimensions (W×H×D)	430×125×289 mm
Weight	4.6 kg

### Notes:

1. Specifications are subject to change without notice.
2. Weight and dimensions shown are approximate.

# Technics

## ■ CONTENTS

	Page		Page
HANDLING PRECAUTIONS FOR TRAVERSE DECK .....	2	MEASUREMENTS AND ADJUSTMENTS .....	12~14
PRECAUTION OF LASER DIODE .....	2, 3	TROUBLESHOOTING GUIDE .....	14~16
INSTALLATION .....	3	SCHEMATIC DIAGRAM .....	17~22
ACCESSORIES .....	3	PRINTED CIRCUIT BOARD DIAGRAM .....	23~26
CAUTION FOR AC MAINS LEAD .....	4	WIRING CONNECTION DIAGRAM .....	27
LOCATION OF CONTROLS .....	5, 6	BLOCK DIAGRAM .....	28, 29
BASIC OPERATING PROCEDURE .....	6	FUNCTION OF IC TERMINALS .....	30~33
CONNECTIONS .....	7	REPLACEMENT PARTS LIST .....	34~38
CLEANING OF LENS .....	7	PACKAGING .....	37
DISASSEMBLY INSTRUCTIONS .....	8~11	CABINET PARTS LOCATION .....	39, 40
CHECKING OF THE SERVO P.C.B. ....	11	LOADING UNIT PARTS LOCATION .....	41
CHECKING OF THE MAIN P.C.B. ....	12		

## ■ HANDLING PRECAUTIONS FOR TRAVERSE DECK

The laser diode in the traverse deck (optical pickup) may break down due to potential difference caused by static electricity of clothes or human body.

So, be careful of electrostatic breakdown during repair of the traverse deck (optical pickup).

### ● Handling of traverse deck (optical pickup)

1. Do not subject the traverse deck (optical pickup) to static electricity as it is extremely sensitive to electrical shock.
2. To prevent the breakdown of the laser diode, an anti-static shorting pin is inserted into the flexible board (FPC board). When removing or connecting the short pin, finish the job in as short time as possible.
3. Take care not to apply excessive stress to the flexible board (FPC board).

### ● Grounding for electrostatic breakdown prevention

1. Human body grounding  
Use the anti-static wrist strap to discharge the static electricity from your body.
2. Work table grounding  
Put a conductive material (sheet) or steel sheet on the area where the traverse deck (optical pickup) is placed, and ground the sheet.

#### Caution:

The static electricity of your clothes will not be grounded through the wrist strap. So, take care not to let your clothes touch the traverse deck (optical pickup).

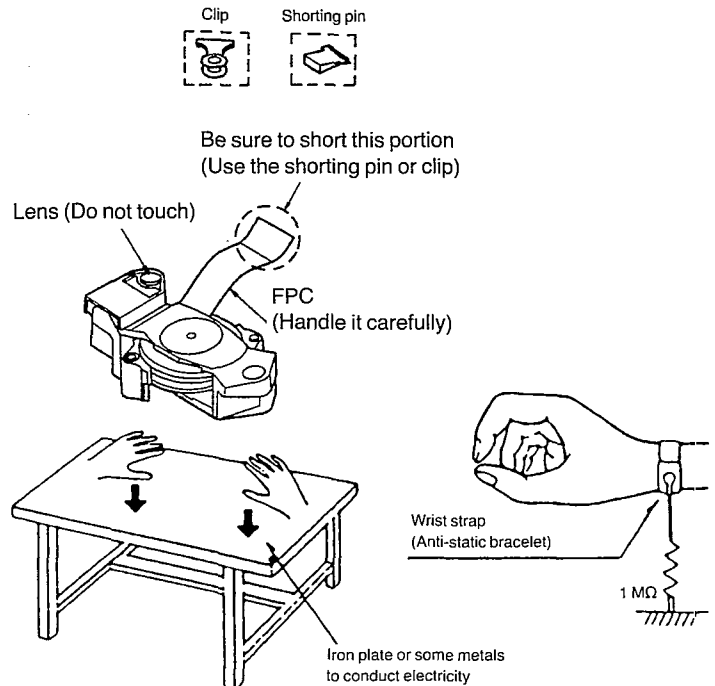

## ■ PRECAUTION OF LASER DIODE

**CAUTION:** This product utilizes a laser diode with the unit turned "on", invisible laser radiation is emitted from the pick up lens.  
Wave length: 780 nm  
Maximum output radiation power from pick up: 100  $\mu$ W/VDE

Laser radiation from the pick up unit is safety level, but be sure the followings:

1. Do not disassemble the optical pick up unit, since radiation from exposed laser diode is dangerous.
2. Do not adjust the variable resistor on the pickup unit. It was already adjusted.
3. Do not look at the focus lens using optical instruments.
4. Recommend not to look at pick up lens for a long time.

**ACHTUNG:** Dieses produkt enthält eine laserdiode. Im eingeschalteten zustand wird unsichtbare laserstrahlung von der lasereinheit abgestrahlt.

Wellenlänge: 780 nm  
Maximale strahlungsleistung der lasereinheit: 100  $\mu$ W/VDE

Die strahlung an der lasereinheit ist ungefährlich, wenn folgende punkte beachtet werden:

1. Die lasereinheit nicht zerlegen, da die strahlung an der freigelegten laserdiode gefährlich ist.
2. Den werkseitig justierten einstellregler der lasereinheit nicht verstellen.
3. Nicht mit optischen instrumenten in die fokussierlinse blicken.
4. Nicht über längere zeit in die fokussierlinse blicken.

**CLASS 1  
LASER PRODUCT**

**LUOKAN 1 LASERLAITE  
KLASS 1 LASER APPARAT**

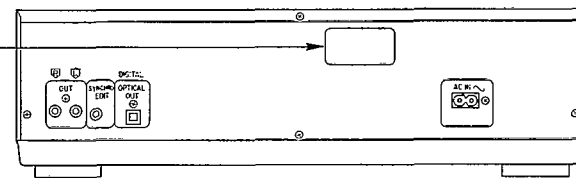

(Rear View)

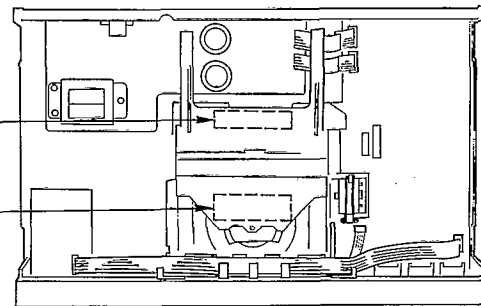

(Top View)

**VARO!**  
AVATTAESSA JA SUOJALUKITUS  
OHITETTAESSA OLET ALTITAIN  
NÄKYMÄTÖN LASERSÄTEILYLLE.  
ÄLÄ KATSO SÄTEESÄN.

**VARNING**  
OSYNLIG LASERSTRÅLNING NÄR  
DENNA DEL ÄR ÖPPNAD OCH  
SPÄRREN ÄR URKOPPLAD.  
BETRAKTA EJ STRÅLEN.

**ADVARSEL**  
USYNLIG LASERSTRÅLNING NÄR  
DEKSEL ÅPNES OG SIKKERHEDSLÅS  
BRYTES. UNIGÅ EKSPONERING FOR  
STRÅLEN. RQLSC074

**ADVARSEL: USYNLIG LASERSTRÅLING  
VED ÅBNING, NÅR SIKKERHEDSAF-  
BRYDERE ER UDE AF FUNKTION.  
UNDGÅ UDSÆTTELSE FOR STRÅLING.**

**VORSICHT**  
Unsichtbare  
Laserstrahlung, wenn  
Abdeckung geöffnet.  
Nicht dem Strahl  
aussetzen. RQLSD022

## INSTALLATION

### Before placement

Two transport security devices are secured to prevent the optical pickup from damage during transport. Be sure to release them before use.

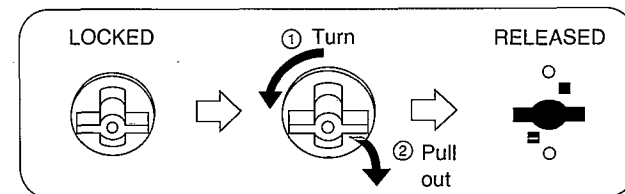

Insert them here after removing. Turn clockwise by 90° to secure them.

Soft cloth or similar material (to prevent scratches)

#### Note:

When transporting the unit, be sure to remove the compact disc from inside the unit. And replace the transport security devices again following the reverse order not to damage the optical pickup.

### Notes of placement

**This unit is a precision instrument. Be sure to place it on a flat surface.**

#### Avoid places such as the following:

- Near any equipment or device that generates strong magnetism.
- On any heat-generating equipment or device, or in any place where the temperature is high (35°C or higher).
- Extremely cold place (5°C or below).
- Near a tuner or TV. (It may cause noise in the broadcast, or disturbance of the TV picture.)

**When carrying or storing the unit, handle it with care so it is not subjected to any strong bumps.**

Always remove the disc before storing the unit for any period of time.

#### To avoid problems due to vibration

- Do not place a book or similar object under this unit.
- Do not route the connection cables (of this or other units) across the operation panel, across the top, or under the unit.

## ACCESSORIES

#### Note:

The configuration of the AC power supply cord differs according to area.

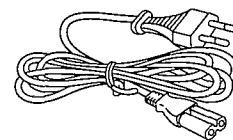

AC power supply cord for (E) and (EG) areas...(RJA0019-2K) 1

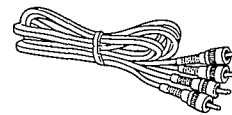

Stereo connection cable (SJP2249-3) 1

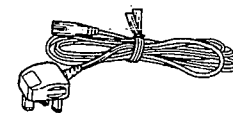

for (EB) area...(VJA0733) 1

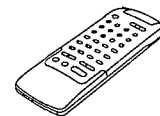

Remote control transmitter (EUR642100) 1

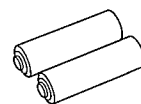

Batteries UM-4 (AAA, R03) 2 for remote control transmitter

#### Note:

These are available on sale route.



## CAUTION FOR AC MAINS LEAD (For United Kingdom)

("EB" area code model only)

For your safety, please read the following text carefully.

This appliance is supplied with a moulded three pin mains plug for your safety and convenience.

A 5-ampere fuse is fitted in this plug.

Should the fuse need to be replaced please ensure that the replacement fuse has a rating of 5-ampere and that it is approved by ASTA or BSI to BS1362. Check for the ASTA mark  or the BSI mark  on the body of the fuse.

If the plug contains a removable fuse cover you must ensure that it is refitted when the fuse is replaced.

If you lose the fuse cover the plug must not be used until a replacement cover is obtained.

A replacement fuse cover can be purchased from your local dealer.

**WARNING: DO NOT CONNECT EITHER WIRE TO THE EARTH TERMINAL WHICH IS MARKED WITH THE LETTER E, BY THE EARTH SYMBOL  OR COLOURED GREEN OR GREEN/YELLOW.**

**THIS PLUG IS NOT WATERPROOF—KEEP DRY.**

### Before use

Remove the connector cover as follows.

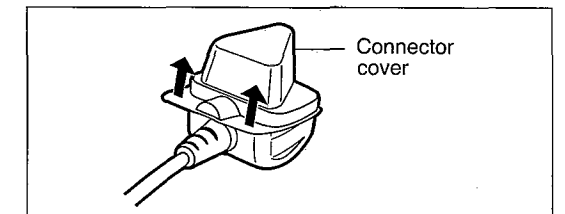

### How to replace the fuse

1. Open the fuse cover with a screwdriver.

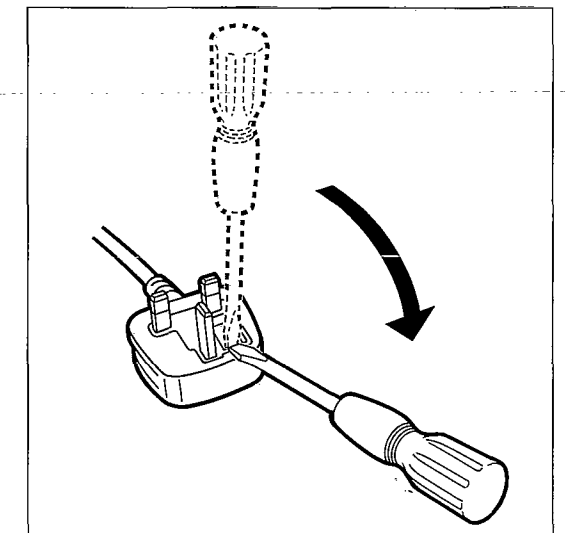

### CAUTION!

IF THE FITTED MOULDED PLUG IS UNSUITABLE FOR THE SOCKET OUTLET IN YOUR HOME THEN THE FUSE SHOULD BE REMOVED AND THE PLUG CUT OFF AND DISPOSED OF SAFELY. THERE IS A DANGER OF SEVERE ELECTRICAL SHOCK IF THE CUT OFF PLUG IS INSERTED INTO ANY 13-AMPERE SOCKET.

If a new plug is to be fitted please observe the wiring code as shown below.

If in any doubt please consult a qualified electrician.

### IMPORTANT

The wires in this mains lead are coloured in accordance with the following code:

Blue: Neutral, Brown: Live.

As these colours may not correspond with the coloured markings identifying the terminals in your plug, proceed as follows:

The wire which is coloured Blue must be connected to the terminal which is marked with the letter N or coloured Black or Blue.

The wire which is coloured Brown must be connected to the terminal which is marked with the letter L or coloured Brown or Red.

2. Replace the fuse.

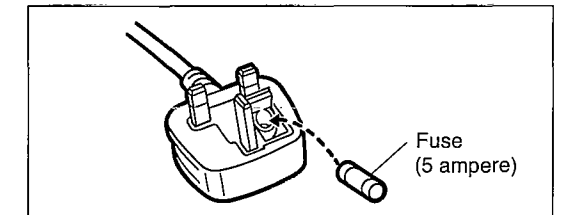

3. Close the fuse cover.

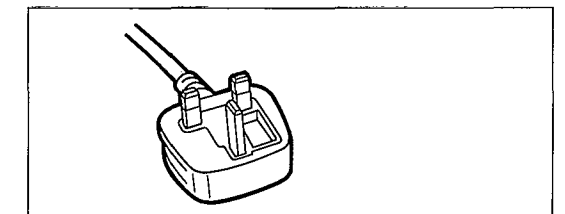

■ LOCATION OF CONTROLS

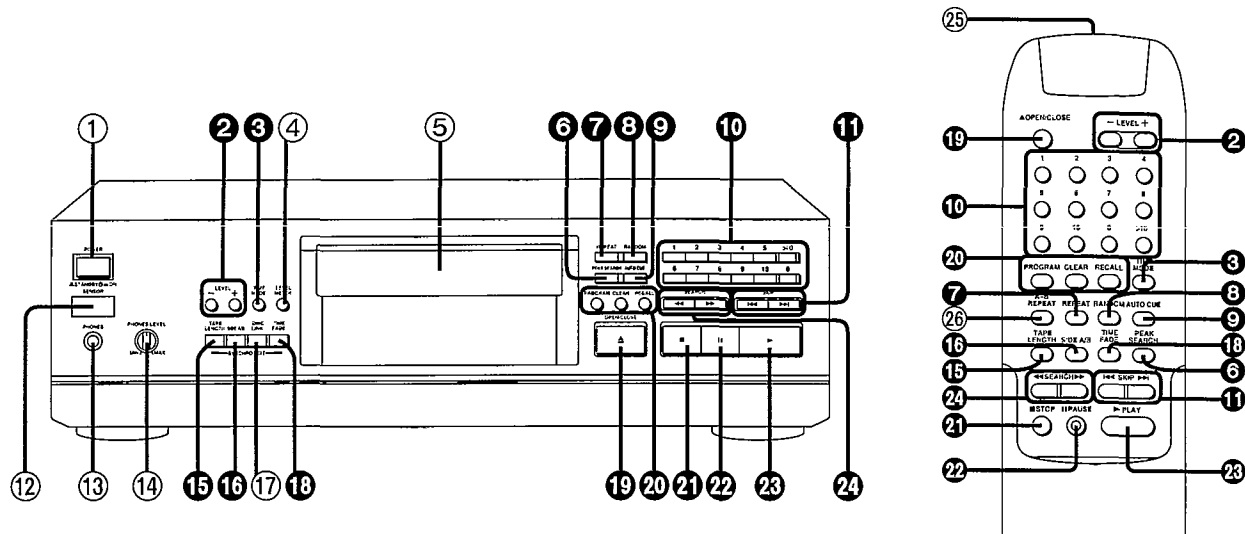

**Control section**

Numbers with black background (for example 2) indicate functions available on the remote control.

- ① Power "STANDBY ⏻/ON" switch (POWER, **■** STANDBY ⏻ **■** ON)  
Press to switch the unit from on to standby mode or vice versa. In standby mode, the unit is still consuming a small amount of power.
- ② Level control buttons (- LEVEL +)
- ③ Time mode select button (TIME MODE)
- ④ Output level meter on/off button (LEVEL METER)
- ⑤ Disc tray
- ⑥ Peak search button (PEAK SEARCH)
- ⑦ Repeat button (REPEAT)
- ⑧ Random play button (RANDOM)
- ⑨ Auto cue button (AUTO CUE)
- ⑩ Numeric buttons (1-10, >10, 0)
- ⑪ Skip buttons (⏮, ⏭) SKIP
- ⑫ Remote control signal sensor (SENSOR)

- ⑬ Headphones jack (PHONES) (∅6, 32Ω)
- ⑭ Headphones volume control (PHONES LEVEL)
- ⑮ Tape length button (TAPE LENGTH)
- ⑯ Tape side select button (SIDE A/B)
- ⑰ Disc link button (DISC LINK)
- ⑱ Time fade button (TIME FADE)
- ⑲ Disc tray open/close button (▲ OPEN/CLOSE)
- ⑳ Buttons for program function
  - Program button (PROGRAM)
  - Clear button (CLEAR)
  - Recall button (RECALL)
- ㉑ Stop button (■)
- ㉒ Pause button (⏸)
- ㉓ Play button (▶)
- ㉔ Search buttons (◀◀, ▶▶) SEARCH

**Remote control section**

- ㉕ Remote control transmission window
- ㉖ A-B repeat button (A-B REPEAT)
- ㉗ PROGRAM
- ㉘ RANDOM
- ㉙ T.FADE
- ㉚ A-B
- ㉛ A.CUE
- ㉜ LINK
- ㉝ LEVEL
- ㉞ TRACK No.
- ㉟ INDEX
- ㊱ MIN
- ㊲ SEC
- ㊳ EDIT
- ㊴ PEAK
- ㊵ 1
- ㊶ 2
- ㊷ 3
- ㊸ 4
- ㊹ 5
- ㊺ 6
- ㊻ 7
- ㊼ 8
- ㊽ 9
- ㊾ 10
- ㊿ 11
- 12
- 13
- 14
- 15
- 16
- 17
- 18
- 19
- 20
- ㊿ 0
- ㊿ -50
- ㊿ -40
- ㊿ -30
- ㊿ -20
- ㊿ -16
- ㊿ -10
- ㊿ -6
- ㊿ 0

**Display section**

- ㉑ Pause indicator (⏸)
- ㉒ Play indicator (▶)
- ㉓ Time fade/fade out indicator (T.FADE)
- ㉔ Random play indicator (RANDOM)
- ㉕ Program indicator (PROGRAM)
- ㉖ Repeat indicator (◻)
- ㉗ A-B repeat indicator (A-B)
- ㉘ Disc link indicator (LINK)
- ㉙ Auto cue indicator (A.CUE)
- ㉚ Track number display
- ㉛ Level control indicator (LEVEL)
- ㉜ Index/program sequence display
- ㉝ Time display
- ㉞ Track number indicator (1 - 20)
- ㉟ Compact disc edit indicator (EDIT)
- ㊱ Peak search indicator (PEAK)
- ㊲ Tape side indicator (▶A, ▶B)
- ㊳ Output level indicator (dB)
- ㊴ "Over" mark (▶)

■ BASIC OPERATING PROCEDURE

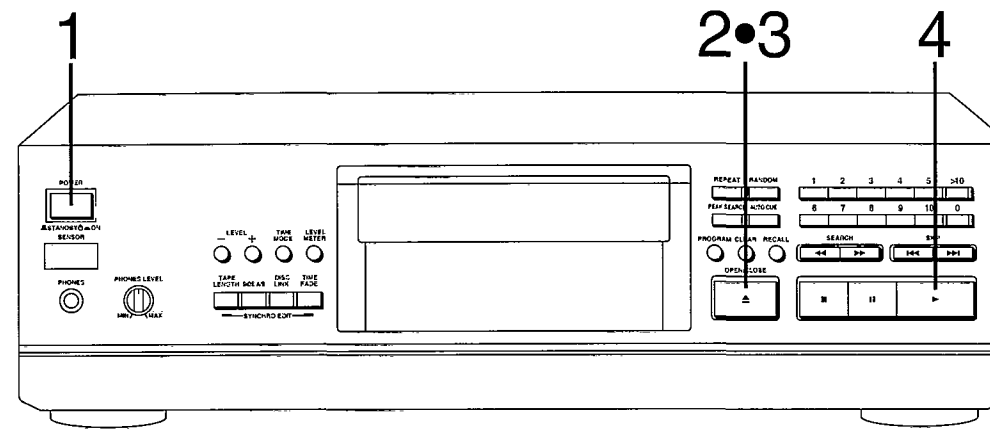

- 1 Press POWER to switch on the power.  
If there is a disc in the disc tray, play will start from the first track.
- 2 Press open/close button ▲ to open the disc tray and insert a disc.  
(Also available from the remote control)  
Label must face upward.
- 3 Press open/close button ▲ again to close the disc tray.  
(Also available from the remote control)

- The total playing time displayed includes the silent sections between tracks. For this reason, it may be a few seconds longer than the playing time indicated on the disc.
- You can skip this step and press play button ▶. The disc tray will be automatically closed and then play will start from the first track.

- 4 Press play button ▶.  
(Also available from the remote control)

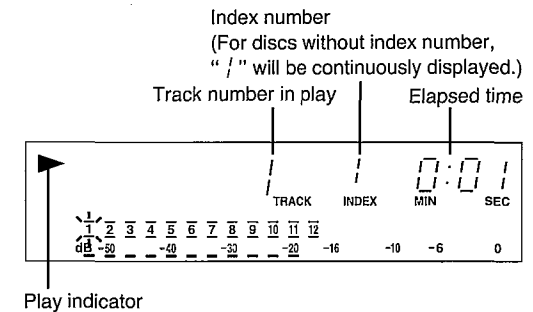

Before attempting to use the remote control transmitter to open the disc tray, make sure that there are no obstructions in front of the unit.

- 3 Press open/close button ▲ again to close the disc tray.  
(Also available from the remote control)

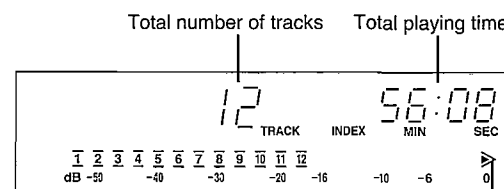

Lights when the total number of tracks exceeds 21

The unit stops automatically when the last track finishes playing.

## ■ CONNECTIONS

Before making connections, be sure that the power of this unit and all other system components is first turned off.

See the operating instructions of the amplifier or the cassette deck for details.

### Note:

The configuration of the AC outlet and AC power supply cord differs according to area.

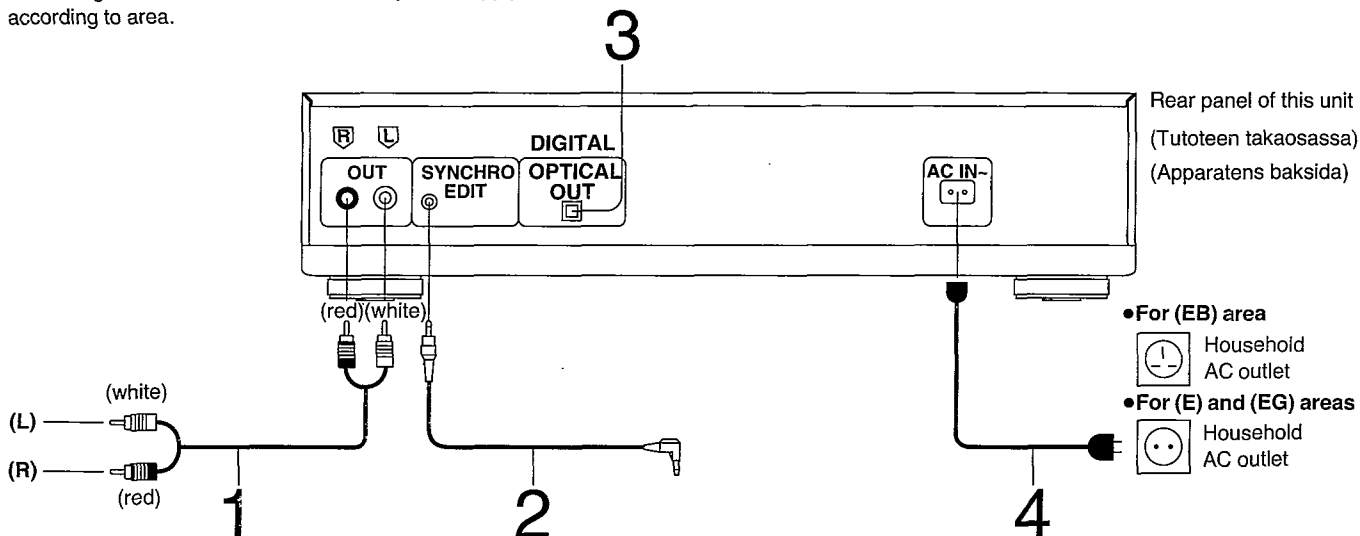

- 1 Connect the stereo connection cable (included) to the "CD" or "AUX" terminals of the amplifier.
- 2 Connect the synchro edit cable (included with the cassette deck) to the "SYNCHRO EDIT" terminal of the Technics cassette deck which is equipped with the synchro edit function.
- 3 Connect the optical-fiber cable (not included) to the "DIGITAL INPUT" terminal of the amplifier.

This terminal can be used for connection with other equipment that has a digital input terminal, such as an amplifier, by using an optical-fiber cable (not included). A dust-protection cap is inserted in this terminal. Remove this cap only when a connection is to be made to this terminal.

**FOR UNITED KINGDOM ONLY**  
BE SURE TO READ THE CAUTION FOR AC POWER SUPPLY CORD ON PAGE 3 BEFORE PROCEEDING TO STEP 4.

- 4 Connect the AC power supply cord (included) to the "AC OUTLET" of the amplifier or the household AC outlet.

#### Insertion of Connector

Even when the connector is perfectly inserted, depending on the type of inlet used, the front part of the connector may jut out as shown in the drawing.

However there is no problem using the unit.

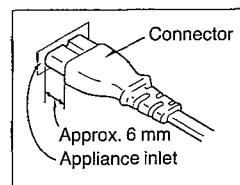

## ■ CLEANING OF LENS

If the lens is stained causing sound skip or operation failure, open the top cover by pressing the open button, and clean the lens.

### • To remove dust or dirt

Blow the lens with the blower provided in the cleaning kit to remove dust or dirt.

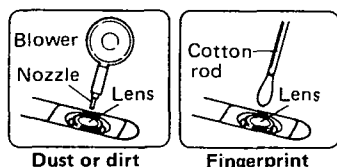

### • To remove fingerprint

If the blower is not enough, moisten the cotton rod with the lens cleaner solution and wipe the lens with it from center of the lens to outside.

### Cautions:

- Do not directly apply the cleaner solution to the lens. Do not apply too much solution to the cotton rod or otherwise the solution will flow into the player.
- Wipe the lens carefully. Do not give too much stress to the lens or otherwise it may scratch the lens or cause optical pickup trouble.
- If the solution should be too much applied, wipe the lens with a dry cotton rod.

### Lens cleaning kit (Part No. : SZZP1038C)

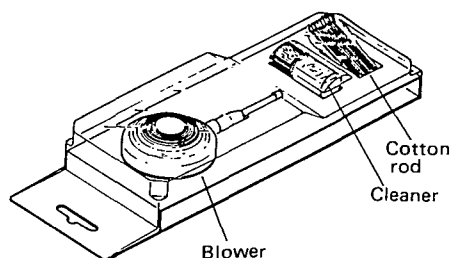

# DISASSEMBLY INSTRUCTIONS

**Warning:** This product uses a laser diode. Refer to caution statements on page 2.

**ACHTUNG:** Die Lasereinheit nicht zerlegen.

Die Lasereinheit darf nur gegen eine vom Hersteller spezifizierte Einheit ausgetauscht werden.

**"ATTENTION SERVICER"** Some chassis components may have sharp edges. Be careful when disassembling and servicing.

\* This CD player is equipped with FPC boards, so handle them with care during disassembly and reassembly.

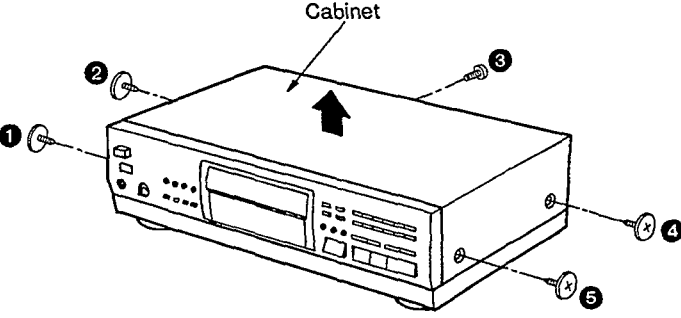
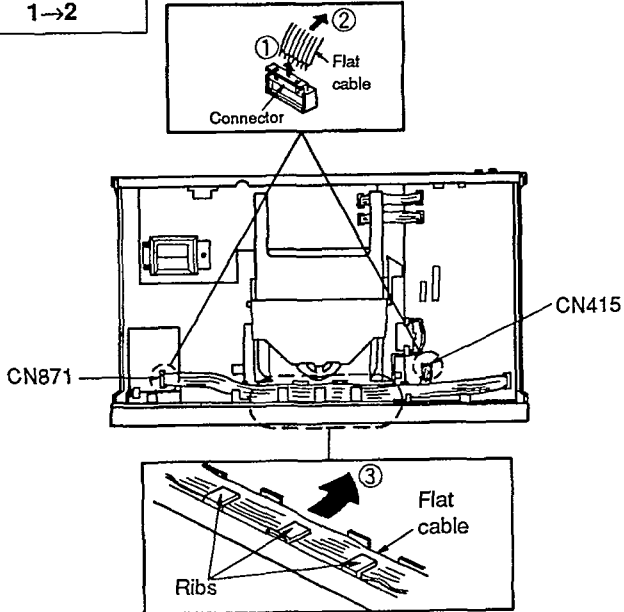
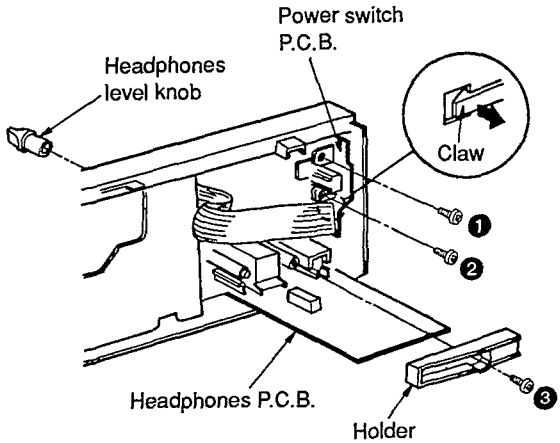
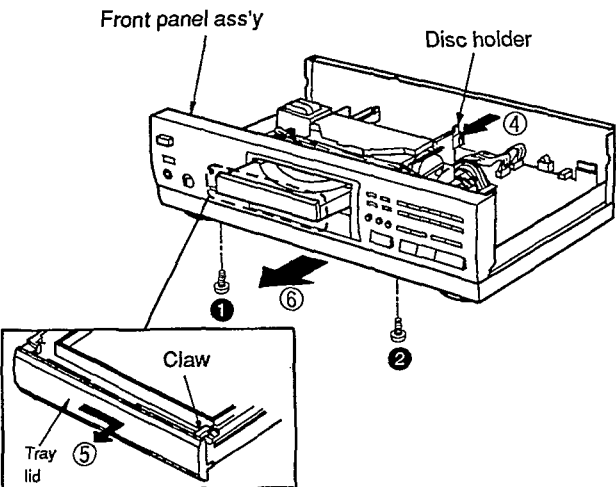
Ref. No. 1	Removal of the cabinet	Ref. No. 2	Removal of the front panel ass'y
Procedure 1	 <p>• Remove the 5 screws (①~⑤).</p>	Procedure 1→2	 <p>1. Remove the 2 connectors (CN415, CN871). 2. Remove the flat cable in the direction of arrow ③.</p>
Ref. No. 3	Removal of the power switch P.C.B. and headphones P.C.B.		
Procedure 1→2→3	 <p>■ <b>Removal of the power switch P.C.B.</b> 1. Remove the 2 screws (①, ②). 2. Release the 1 claw.</p> <p>■ <b>Removal of the headphones P.C.B.</b> 1. Pull out the headphones level knob. 2. Remove the 1 screw (③). 3. Remove the holder.</p>	 <p>[Rear side]</p> <p>3. Push the disc holder slowly in the direction of arrow ④. 4. Release the 1 claw and then remove the tray lid in the direction of arrow ⑤. 5. Remove the 2 screws (①, ②). 6. Remove the front panel ass'y in the direction of arrow ⑥.</p>	

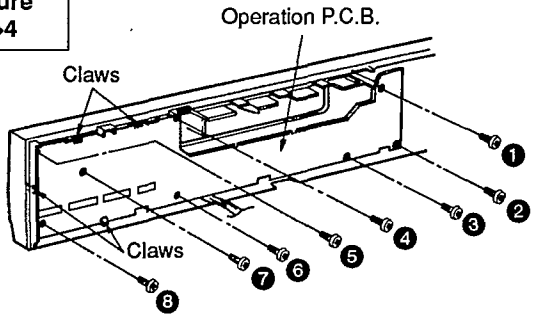
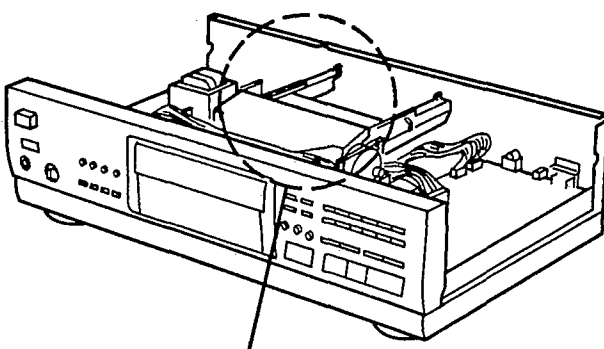
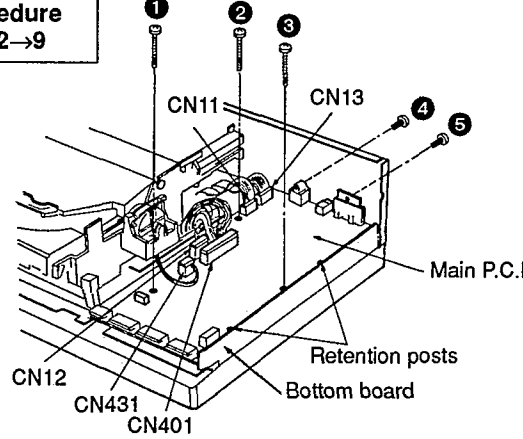
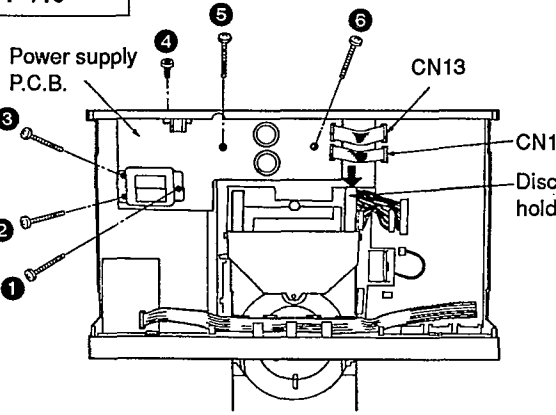
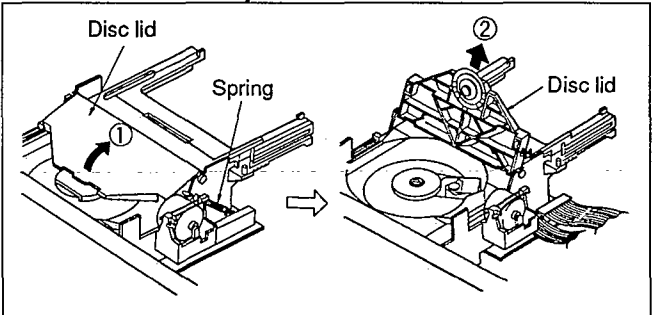
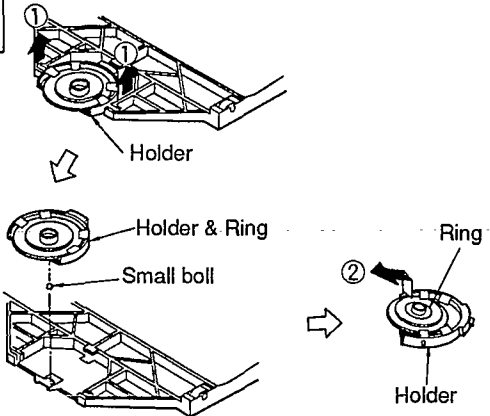
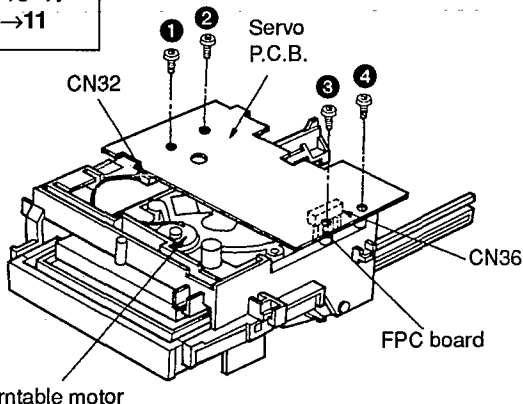
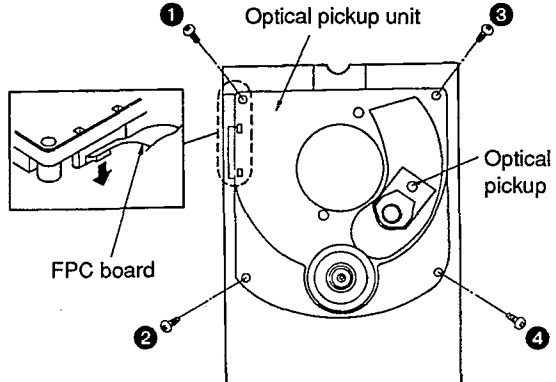
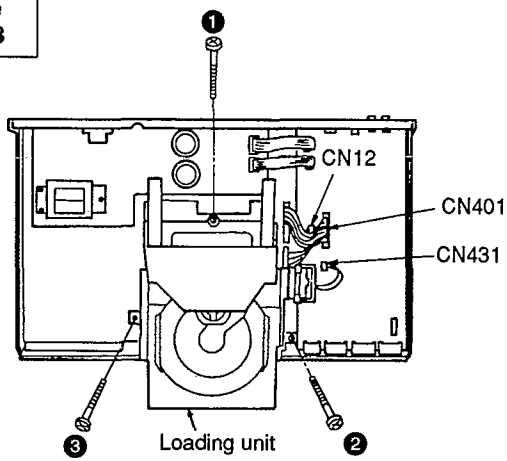
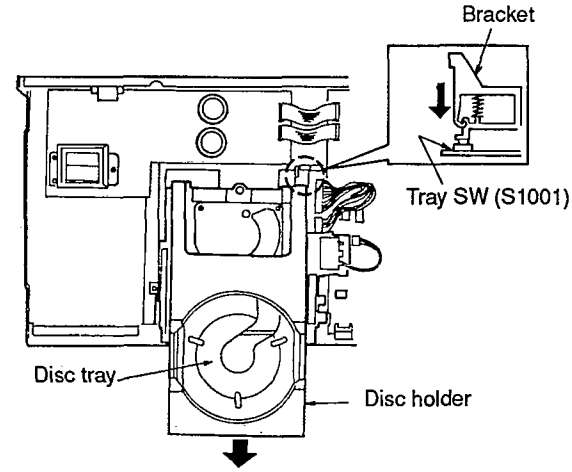
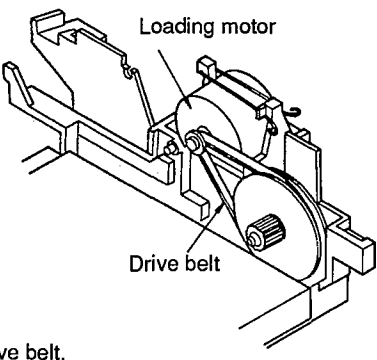
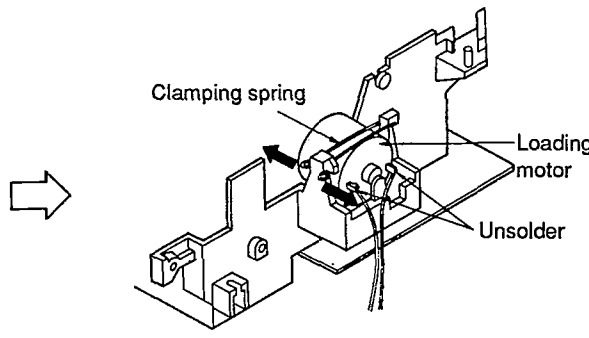
Ref. No. 4	Removal of the operation P.C.B.	Ref. No. 5	Removal of the disc lid	Ref. No. 9	Removal of the main P.C.B.	Ref. No. 10	Removal of the power supply P.C.B.
Procedure 1→2→4	 <p>1. Remove the 8 screws (①~⑧). 2. Release the 4 claws.</p>	Procedure 1→5	<p>1. Remove the spring. 2. Move the disc lid in the direction of arrow ① and pull out this in the direction of arrow ②.</p> 	Procedure 1→2→9	 <p>1. Remove the 5 screws (①~⑤). 2. Remove the 5 connectors (CN11, CN12, CN13, CN401, CN431). 3. Lift the main P.C.B. off the retention posts on the bottom board.</p>	Procedure 1→10	 <p>1. Push the disc holder slowly in the direction of arrow. 2. Remove the 6 screws (①~⑥). 3. Remove the 2 connectors (CN11, CN13).</p>
Ref. No. 6	Removal of the holder and ring		Ref. No. 11	Removal of the servo P.C.B.	Ref. No. 12	Removal of the optical pickup unit	
Procedure 1→5→6	 <p>1. Pull out the holder in the direction of arrow ①. 2. Remove the ring in the direction of arrow ②.</p> <p><b>Caution:</b> Be sure to handle the small ball carefully.</p>		Ref. No. 7	Procedure 1→2→5→7 →8→11	 <p>1. Remove the 4 screws (①~④). 2. Remove the FPC board (CN36) from the servo P.C.B.. 3. Remove the 1 connector (CN32) of the turntable motor.</p> <p><b>Caution:</b> To prevent the breakdown of the laser diode, antistatic shorting pin is inserted into the FPC board.</p>	Procedure 1→2→5→7 →8→11→12	 <p>1. Remove the 4 screws (①~④). 2. Remove the FPC board from the optical pickup.</p>
Ref. No. 8	Removal of the loading unit	Procedure 1→2→5→7	Removal of the disc holder	Ref. No. 13	Removal of the loading motor		
Procedure 1→2→5→8	 <p>1. Remove the 3 screws (①~③). 2. Remove the 3 connectors (CN12, CN401, CN431).</p>	Procedure 1→2→5→7	 <p>1. Pull the disc holder slowly in the direction of arrow until the disc tray comes up. 2. Pull the disc holder until it stops. 3. Push the bracket of tray SW (S1001) in the direction of arrow. 4. Pull out the disc holder further to remove it.</p>	Procedure 1→2→5→7 →13	 <p>1. Remove the drive belt.</p>	 <p>2. Release the clamping spring. 3. Unsolder the 2 terminals of the lead wire of the loading motor.</p>	

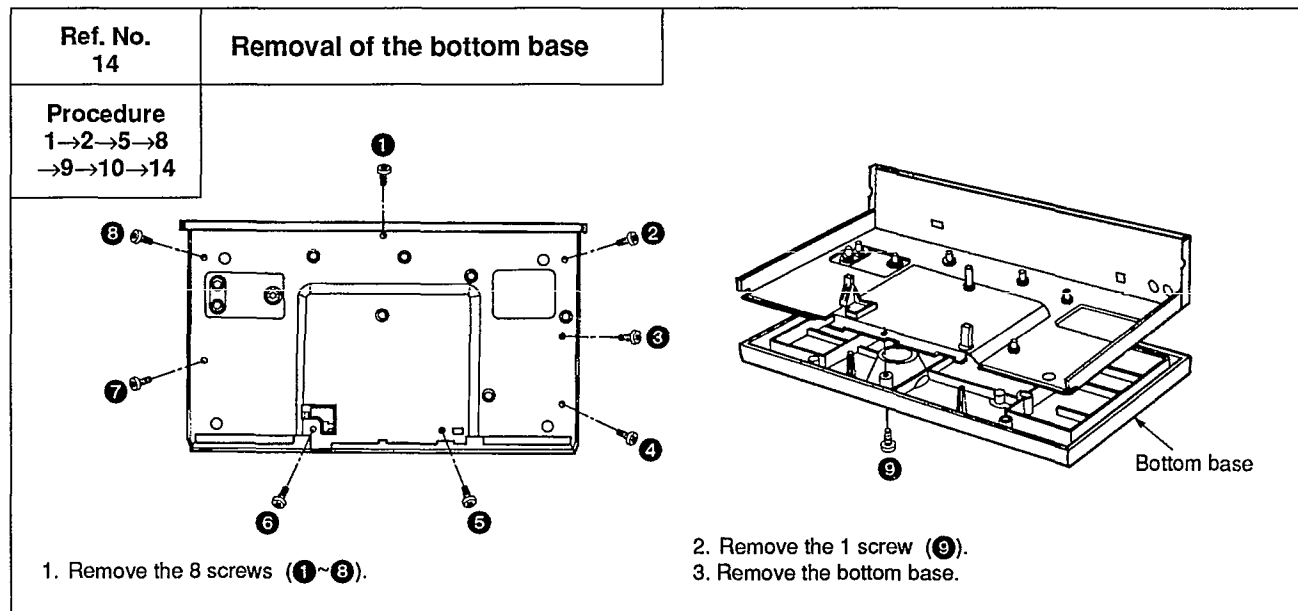

## ■ CHECKING OF THE SERVO P.C.B.

1. Remove the cabinet (see Ref. No.1 of the disassembly instructions).
2. Remove the disc lid and disc holder (see Ref. No. 5 and No. 7 of the same).
3. Remove the loading unit (see Ref. No. 8 of the same).
4. When checking the soldered surface of the servo P.C.B. and replacing the parts, do as shown below.

### (To play a disc)

1. Place the test disc.
2. Reinstall the disc lid to the loading unit.
3. Turn "ON" the power switch of the player.
4. Push the bracket of tray SW (S1001) in the direction of the arrow and release it.

### Note:

If the test disc fails to rotate, press the tray switch again.

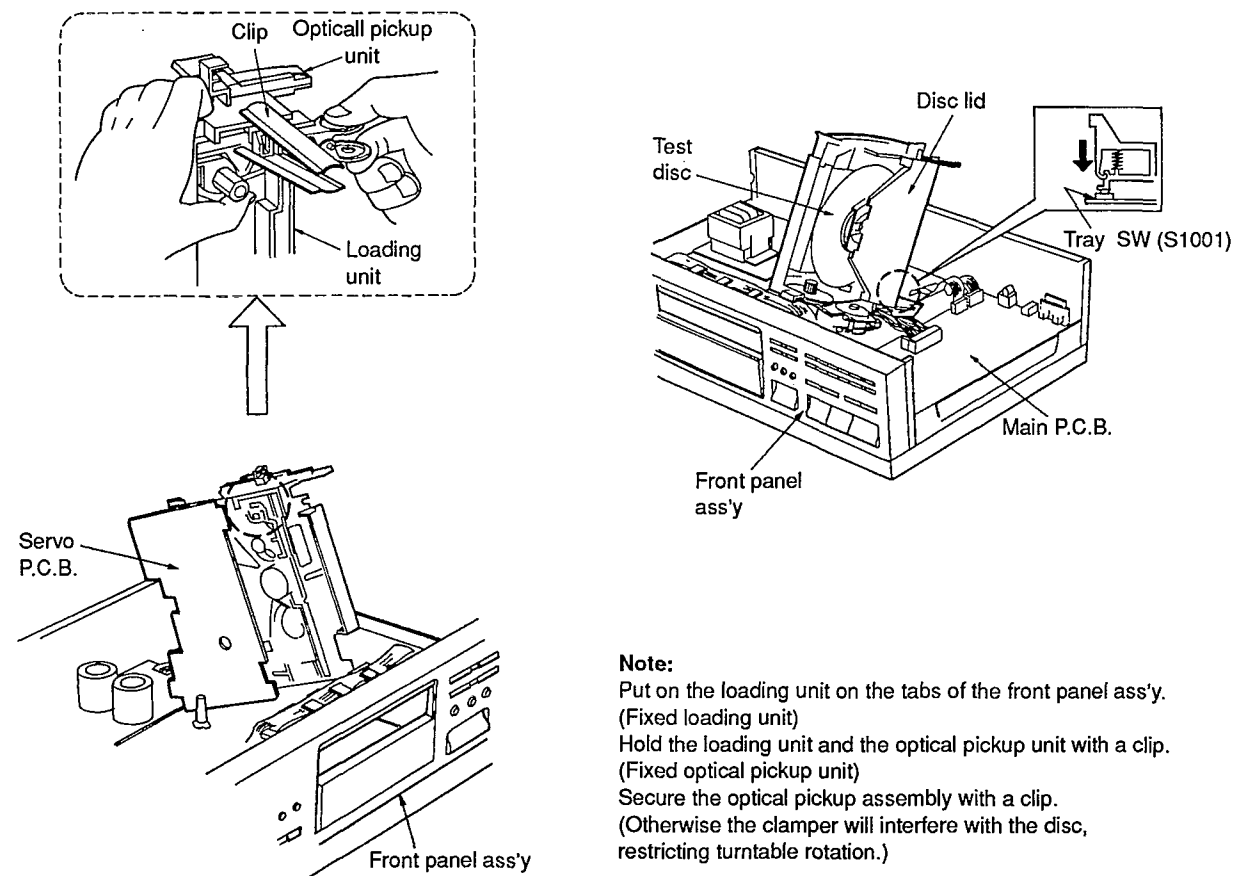

### Note:

Put on the loading unit on the tabs of the front panel ass'y. (Fixed loading unit)  
Hold the loading unit and the optical pickup unit with a clip. (Fixed optical pickup unit)  
Secure the optical pickup assembly with a clip. (Otherwise the clammer will interfere with the disc, restricting turntable rotation.)

## ■ CHECKING OF THE MAIN P.C.B.

1. Remove the cabinet (see Ref. No. 1 of the disassembly instructions).
2. Remove the front panel ass'y (see Ref. No. 2 of the same).
3. Remove the operation P.C.B. (see Ref. No. 4 of the same).
4. Remove the main P.C.B. (see Ref. No. 9 of the same).
5. Don't remove the 7 connectors (CN11, CN12, CN13, CN401, CN415, CN431, CN871).
6. Connect the main P.C.B. ground terminal (LINE OUT terminal) to the rear panel ass'y with a lead wire.

●When checking the soldered surface of the main P.C.B. and replacing the parts, do as shown below.

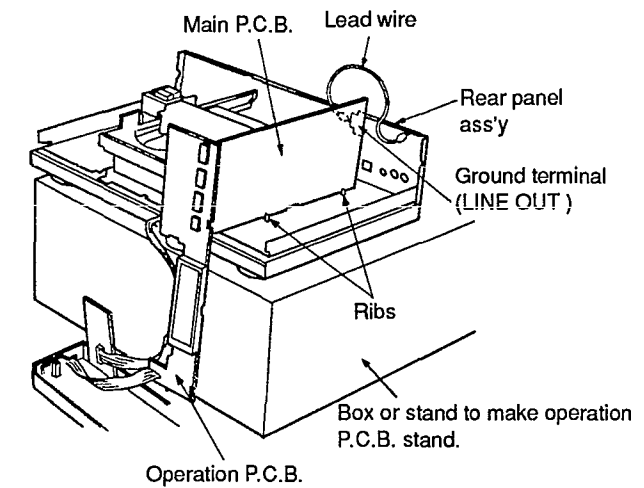

## ■ MEASUREMENTS AND ADJUSTMENTS

### Caution:

1. It is very dangerous to look at or touch the laser beam. (Laser radiation is invisible.)  
With the unit turned "on", laser radiation is emitted from the pickup lens.  
Avoid exposure to the laser beam, especially when performing adjustments.
2. During laser power or focus offset adjustment, never connect the other probe to the unit. (Otherwise the unit's power supply will sustain damage.)

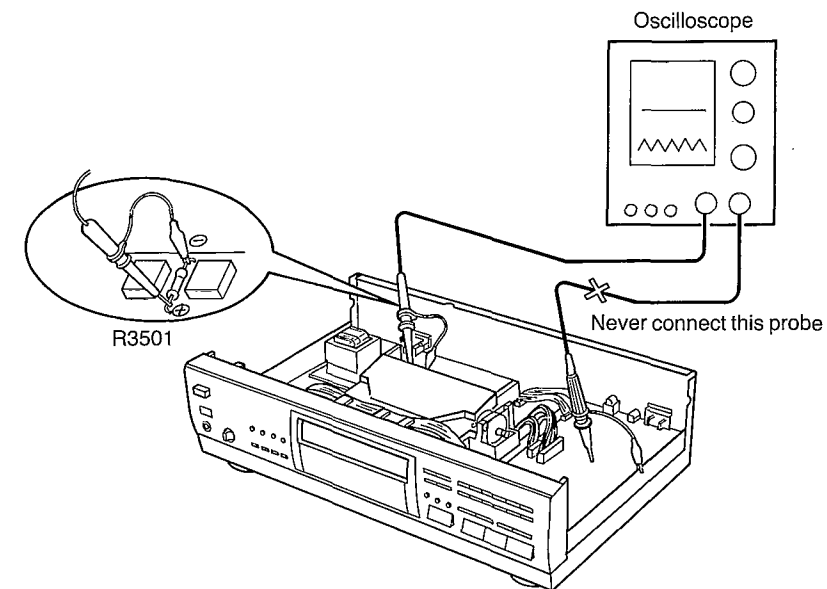

### PREPARATION

1. Remove the cabinet (see Ref No. 1 of the disassembly instructions).
  2. Remove the disc holder (see Ref No. 7 of the same).
  3. Place the test disc on the turntable.
  4. Turn "ON" the power switch at the player.
  5. Push the bracket of tray SW (S1001) in the direction of the arrow and release it.
- Note:** If the test disc fails to rotate, press the tray switch again.

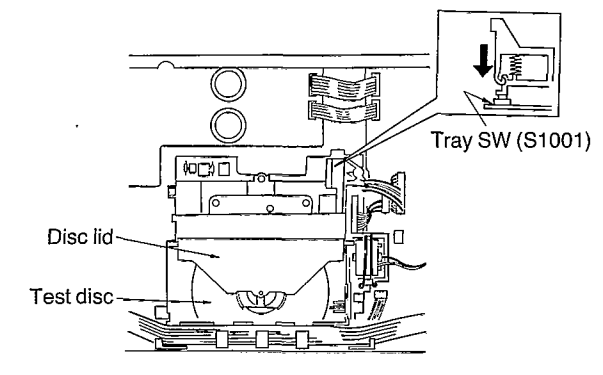



**ADJUSTMENT POINTS**

• Servo P.C.B.

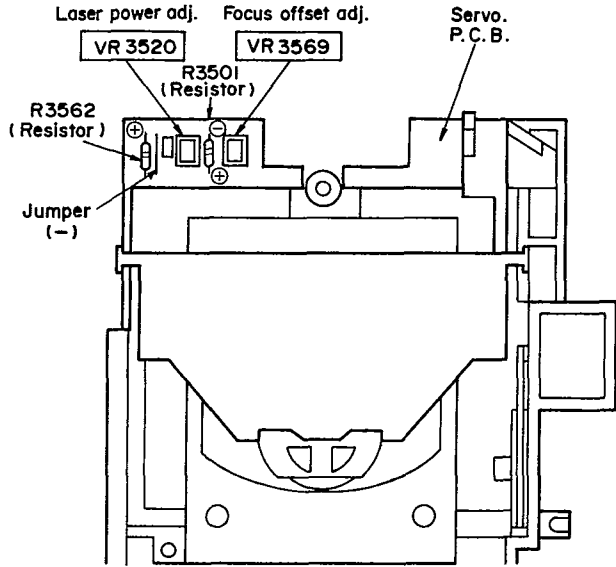

Note:  
Use connector pins to check servo circuit voltages and waveforms.

**POINTS FOR CHECKING OF SERVO CIRCUIT'S VOLTAGE AND WAVEFORM**

(Refer to pages 14~16.)

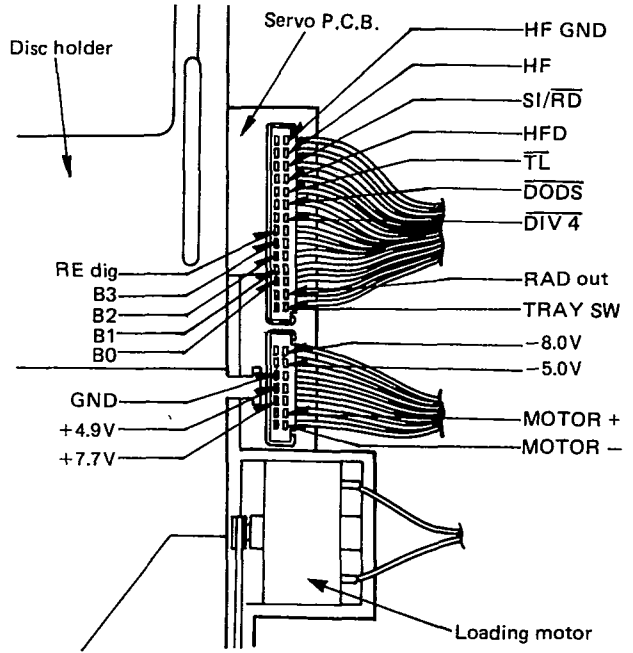

**Measuring Instruments**

- \* Playability test disc (SZZP1054C).
- \* Normal disc (Ordinary musical program disc).

- \* Dual-beam oscilloscope with bandwidth of 30MHz or better (with EXT trigger and 1: 1 probe).

**(1) LASER POWER ADJUSTMENT**

1. Connect the oscilloscope's CH1 probe across (+) and (-) of R3501 (Resistor) on the servo P.C.B.
2. Switch the player power ON, and play track No. 1 on the test disc (SZZP1054C).
3. Adjust VR3520 so that the voltage is  $-50 \pm 2\text{mV}$ .

**Oscilloscope setting:**

VOLT .....20mV  
SWEEP .....0.2msec.  
INPUT .....DC

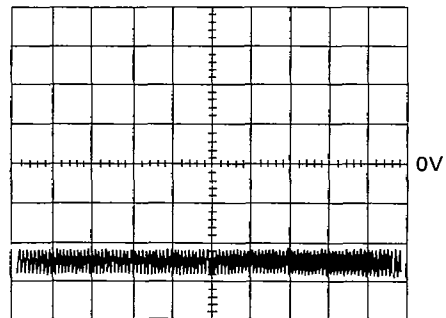

**(2) FOCUS OFFSET ADJUSTMENT**

1. Connect the oscilloscope's CH1 probe across R3562 (Resistor) (+) and Jumper (-) on the servo P.C.B.
2. Switch the player power ON, and play track No. 1 on the test disc (SZZP1054C).
3. Adjust VR3569 until the signal amplitude become in the center of 400mV.

**Oscilloscope setting:**

VOLT .....200mV  
SWEEP .....5msec.  
INPUT .....DC

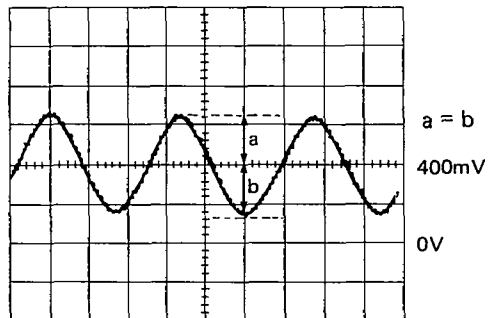

### (3) CHECK OF PLAY OPERATION AFTER ADJUSTMENT

#### \* Checking Skip Search

1. Play an ordinary musical program disc.
2. Press the skip button to check for normal skip search operation (in both the forward and reverse directions).

#### \* Checking Manual Search

1. Play an ordinary musical program disc.
2. Press the manual search button to check for smooth manual search operations at either low or high speed (in both the forward and reverse directions).

#### \* Playability check by test disc

1. Play the 0.7mm black dot and the 0.7mm wedge on the playability test disc (SZZP1054C) and verify that no sound skip or noise occurs.

## ■ TROUBLESHOOTING GUIDE

### SL-PS740A Operation Sequence Check Sheet

#### Play Operation Sequence

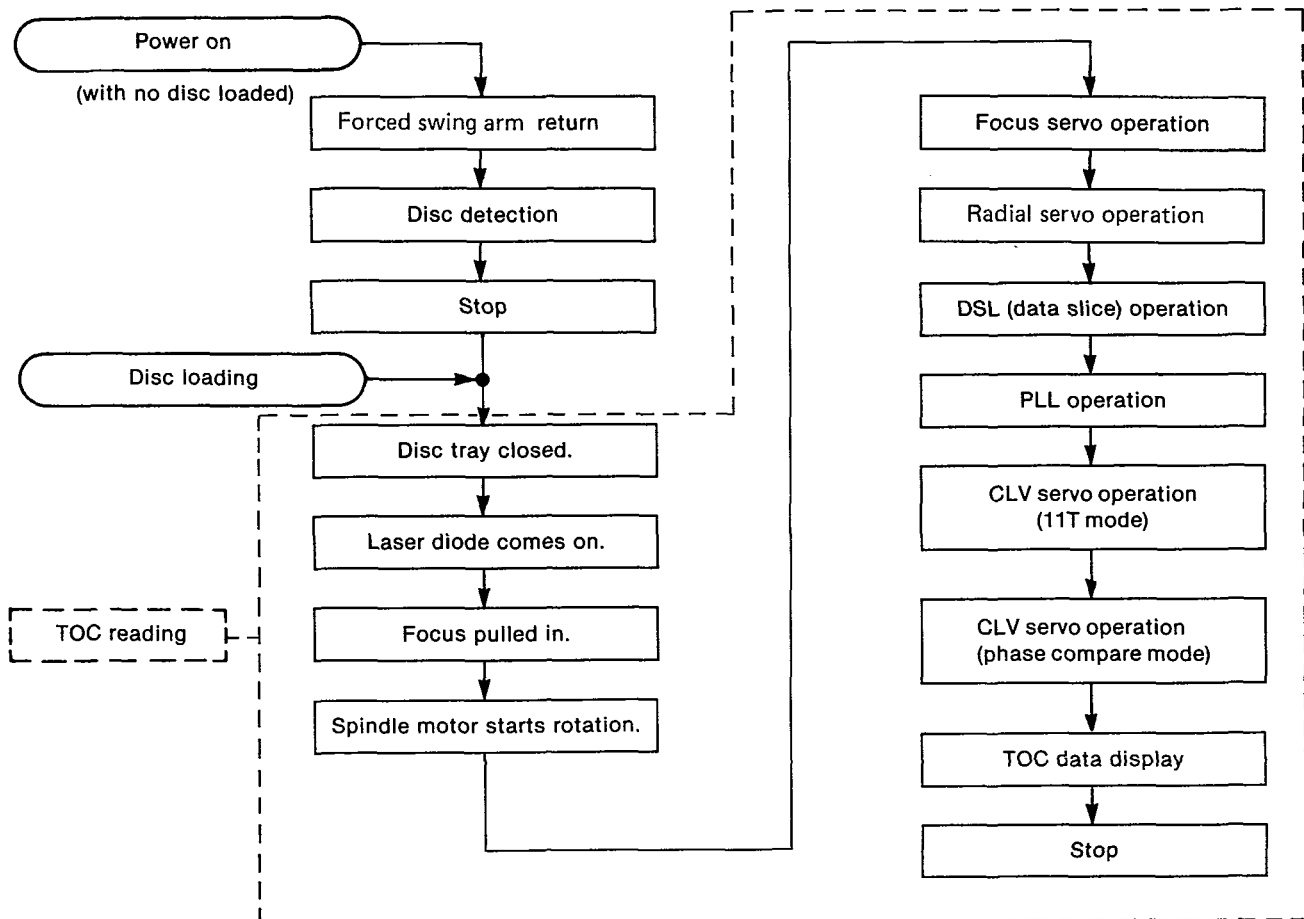

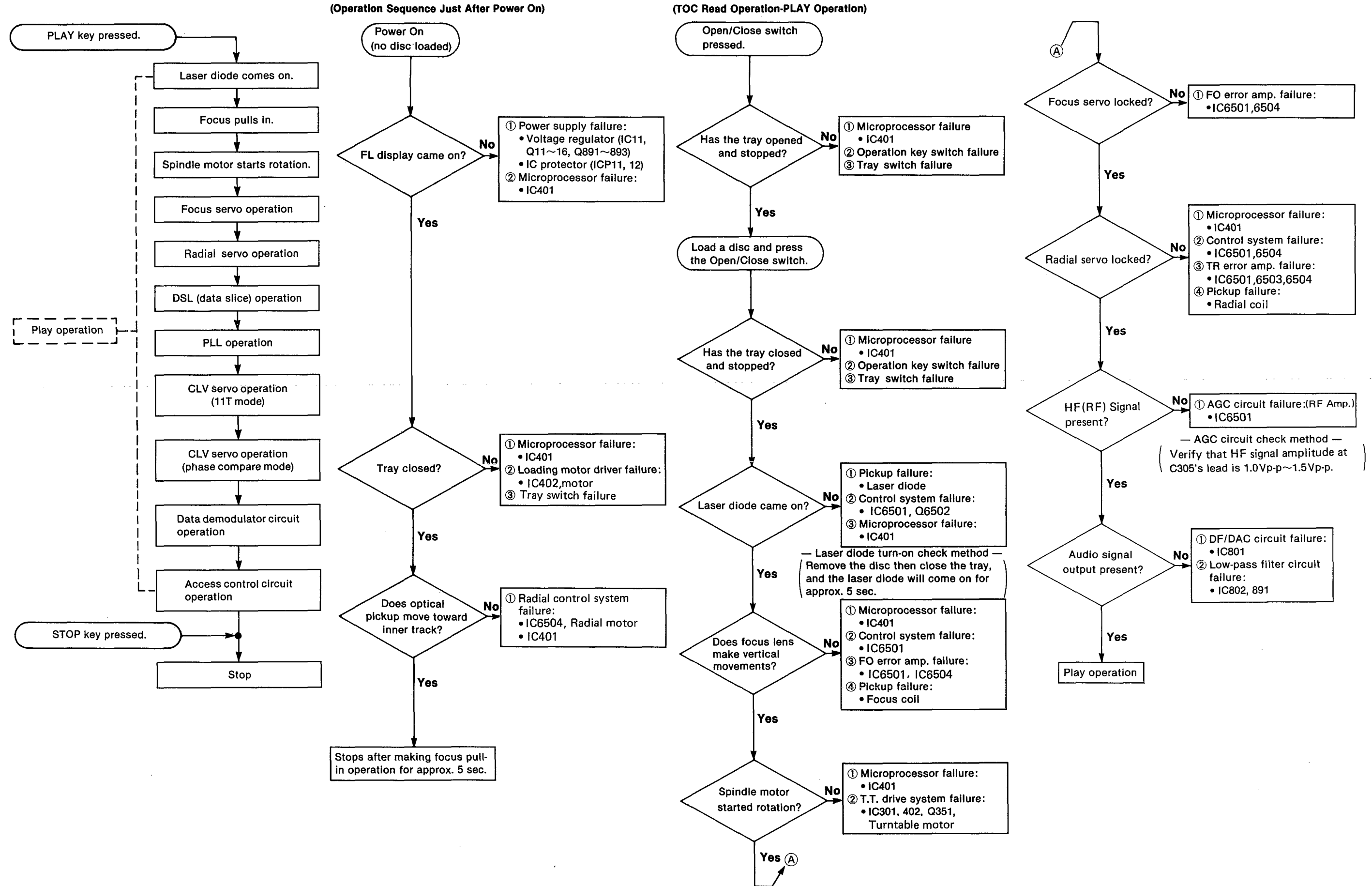

# SCHEMATIC DIAGRAM

(Parts list on pages 34~37)

## Notes:

- S601~612 : Numeric(>10, 0~10) switches
  - S601: 0, S602: 1, S603: 2
  - S604: 3, S605: 4, S606: 5
  - S607: >10, S608: 10, S609: 9
  - S610: 8, S611: 7, S612: 6
- S613 : Play (▶) PLAY switch
- S614 : Skip (◀◀) SKIP switch
- S615 : Search (◀◀) SEARCH switch
- S616 : Program (PROGRAM) switch
- S617 : Disc link (DISC LINK) switch
- S618 : Output level meter on/off (LEVEL METER) switch
- S619 : Stop (■) STOP switch
- S620 : Skip (▶▶) SKIP switch
- S621 : Search (▶▶) SEARCH switch
- S622 : Recall (RECALL) switch
- S623 : Tape side select (SIDE A/B) switch
- S624 : Random (RANDOM) switch
- S625 : Time fade (TIME FADE) switch
- S626 : Disc tray open/close (▲) OPEN/CLOSE switch
- S627 : Pause (||) PAUSE switch
- S628 : Repeat (REPEAT) switch
- S629 : Clear (CLEAR) switch
- S630 : Tape length (TAPE LENGTH) switch
- S631 : Time mode select (TIME MODE) switch
- S632 : Peak search (PEAK SEARCH) switch
- S633 : Level control (LEVEL +) switch
- S634 : Level control (LEVEL -) switch
- S635 : Auto cue (AUTO CUE) switch
- S651 : Power "STANDBY(⏻)/ON" (POWER, ■ STANDBY(⏻) ■ ON) switch in "ON" position
- S1001 : Tray open/close switch

●This schematic diagram may be modified at any time with the development of new technology.

●The voltage value and waveforms are the reference voltage of this unit measured by DC electronic voltmeter (high impedance) and oscilloscope on the basis of chassis. Accordingly, there may arise some error in voltage values and waveforms depending upon the internal impedance of the tester or the measuring unit.

\*The parenthesized are the values of voltage generated during playing (Test disc 1kHz, L+R, 0dB), others are voltage values in stop mode.

●Important safety notice: Components identified by  $\Delta$  mark have special characteristics important for safety. When replacing any of these components, use only manufacturer's specified parts.

●The supply part number is described alone in the replacement parts list.

Part No.	Production Part No.	Supply Part No.
IC11	LM2940T5M	LM2940T5
IC301	MN6626-MC	MN6626
IC803~805	BA4560FT1	SVIBA4560FT1

- — / — : Positive voltage lines and negative voltage lines.
- — : Audio signal lines.

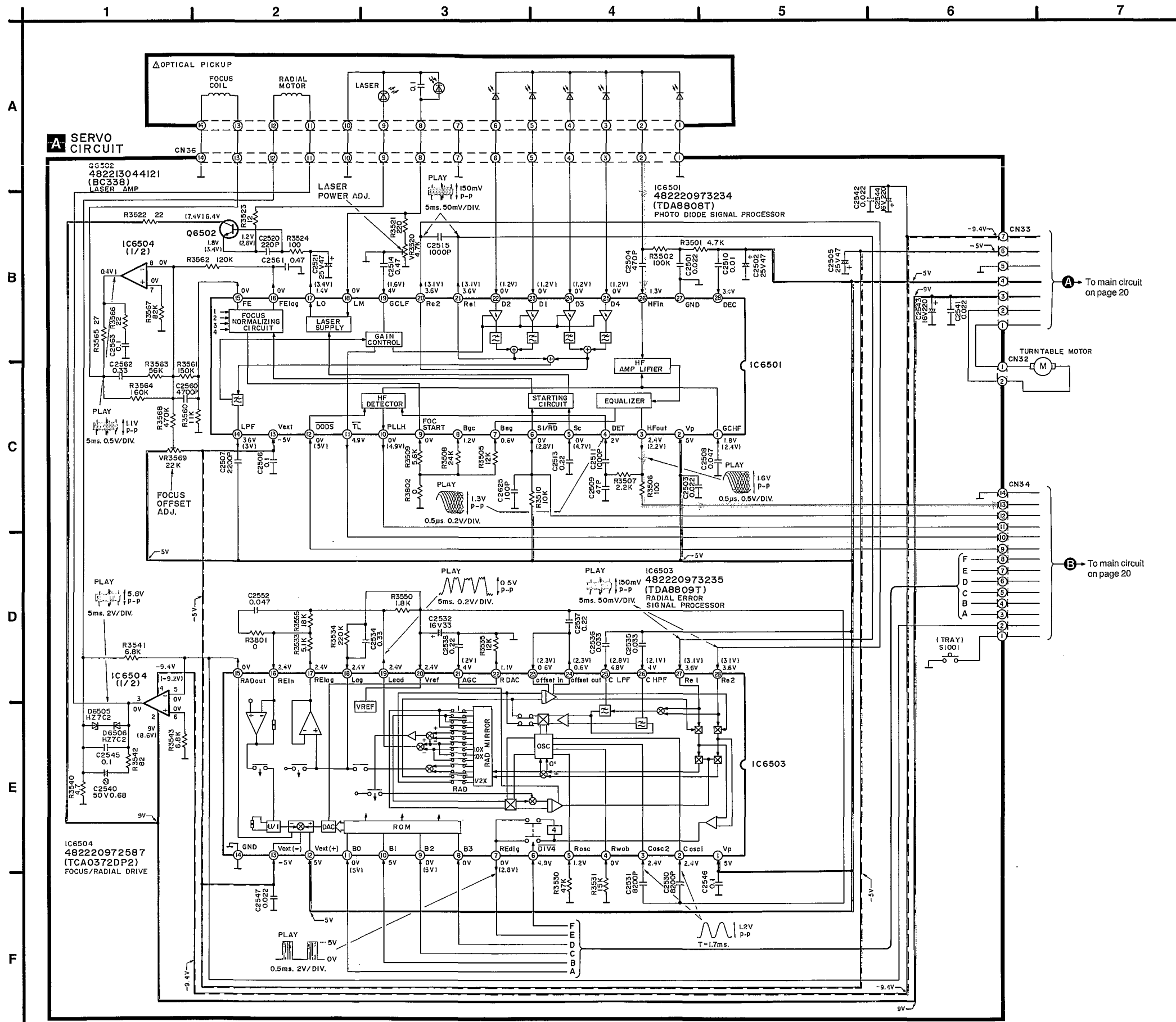

B OPERATION CIRCUIT

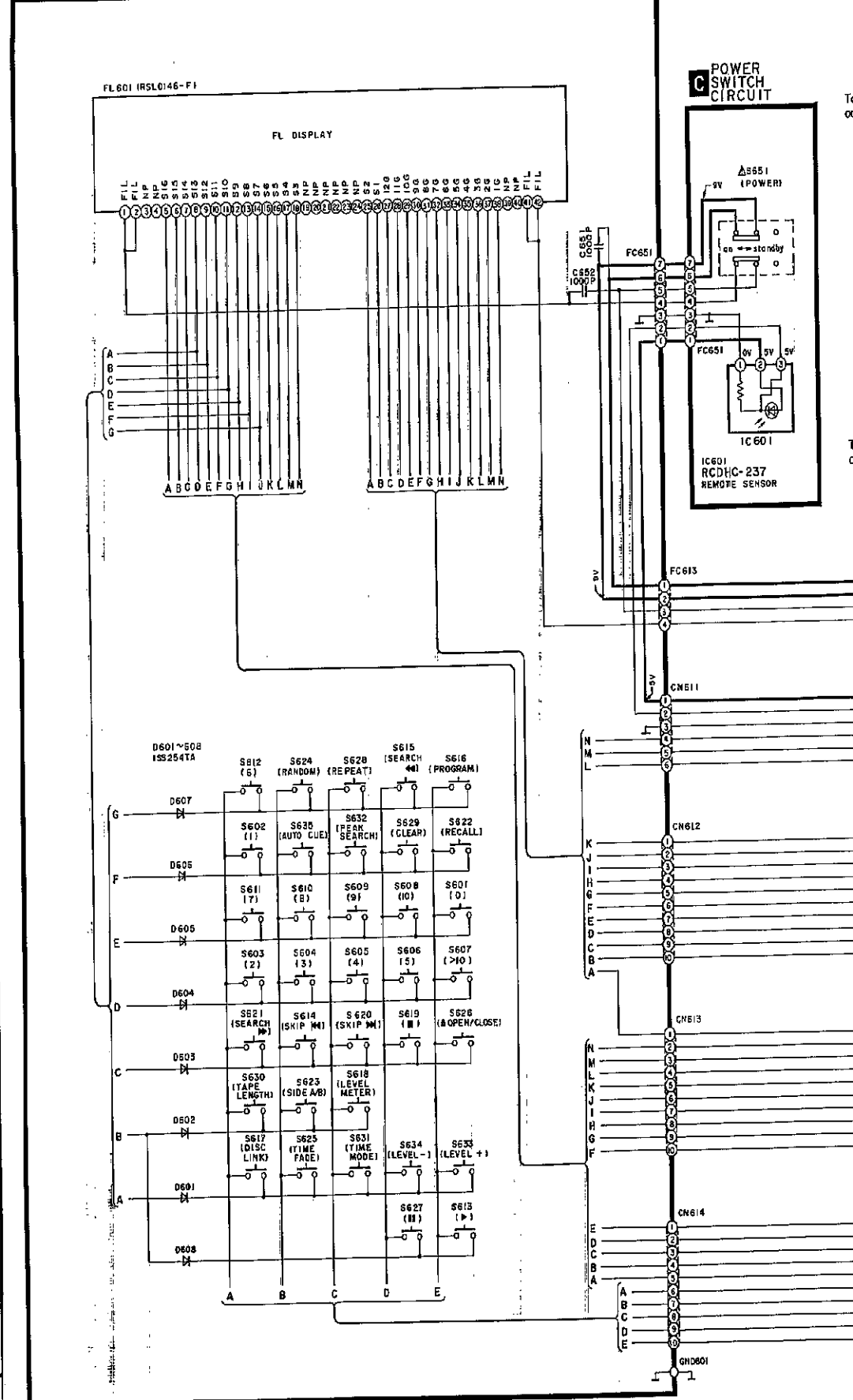

D MAIN CIRCUIT (System control/Digital signal processor/Digital filter/AF out)

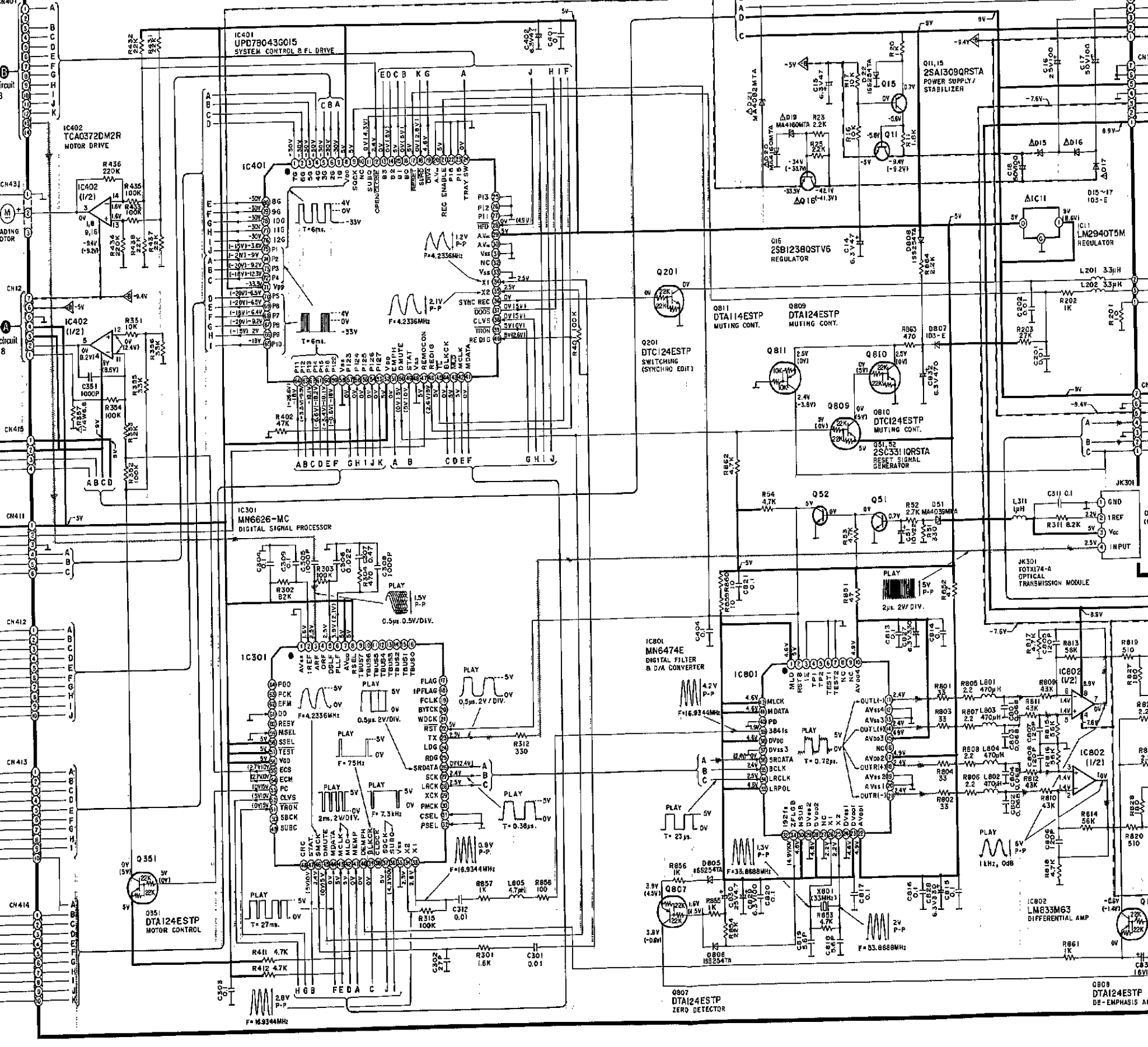

E POWER SUPPLY CIRCUIT

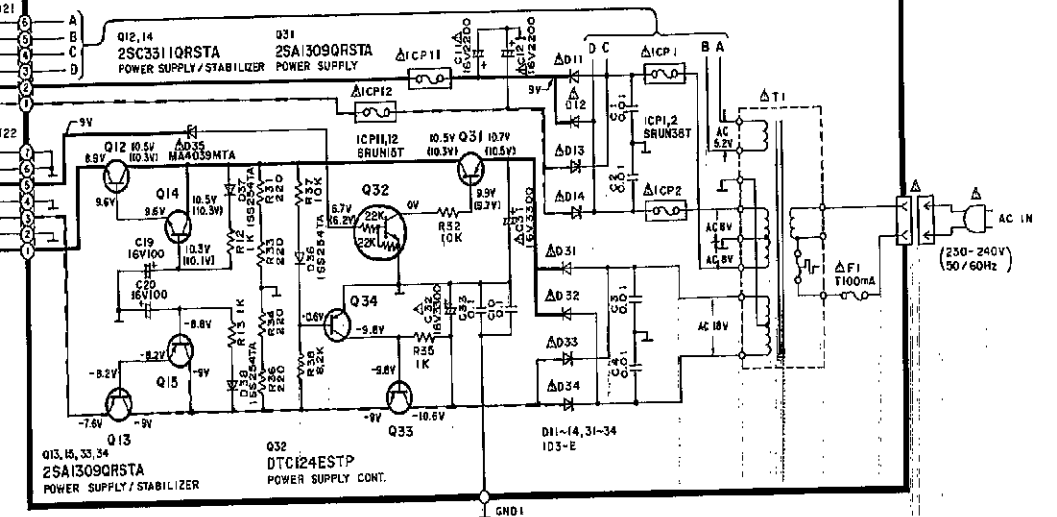

F HEADPHONES CIRCUIT

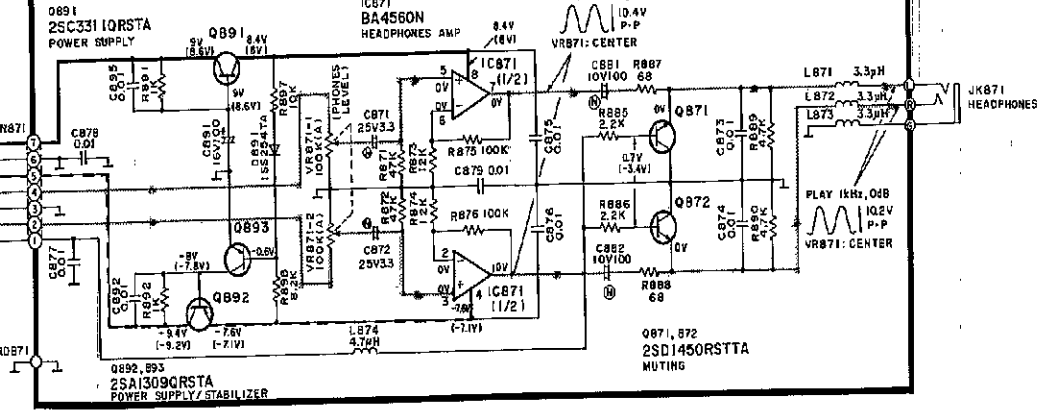

Caution!  
 IC and LSI are sensitive to static electricity.  
 Secondary trouble can be prevented by taking care during repair.  
 • Cover the parts boxes made of plastics with aluminum foil.  
 • Ground the soldering iron.  
 • Put a conductive mat on the work table.  
 • Do not touch the pins of IC or LSI with fingers directly.

PRINTED CIRCUIT BOARD DIAGRAM

This circuit board diagram may be modified at any time with the development of new technology.

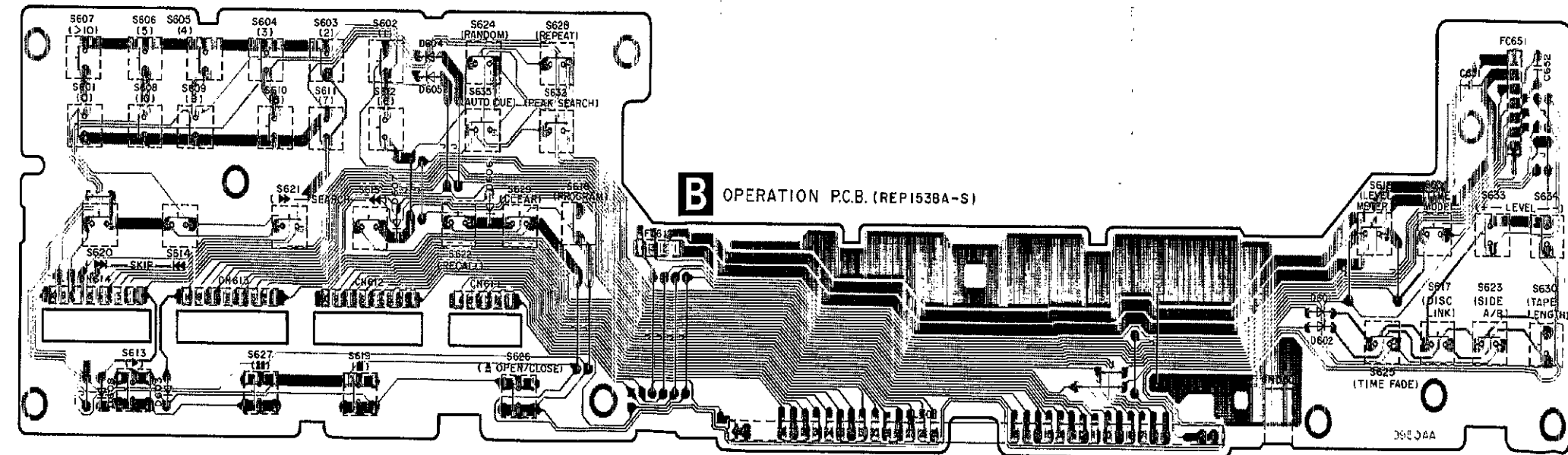
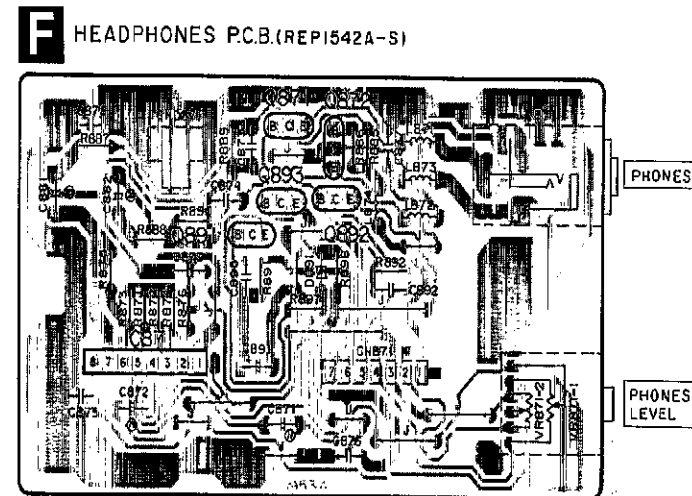
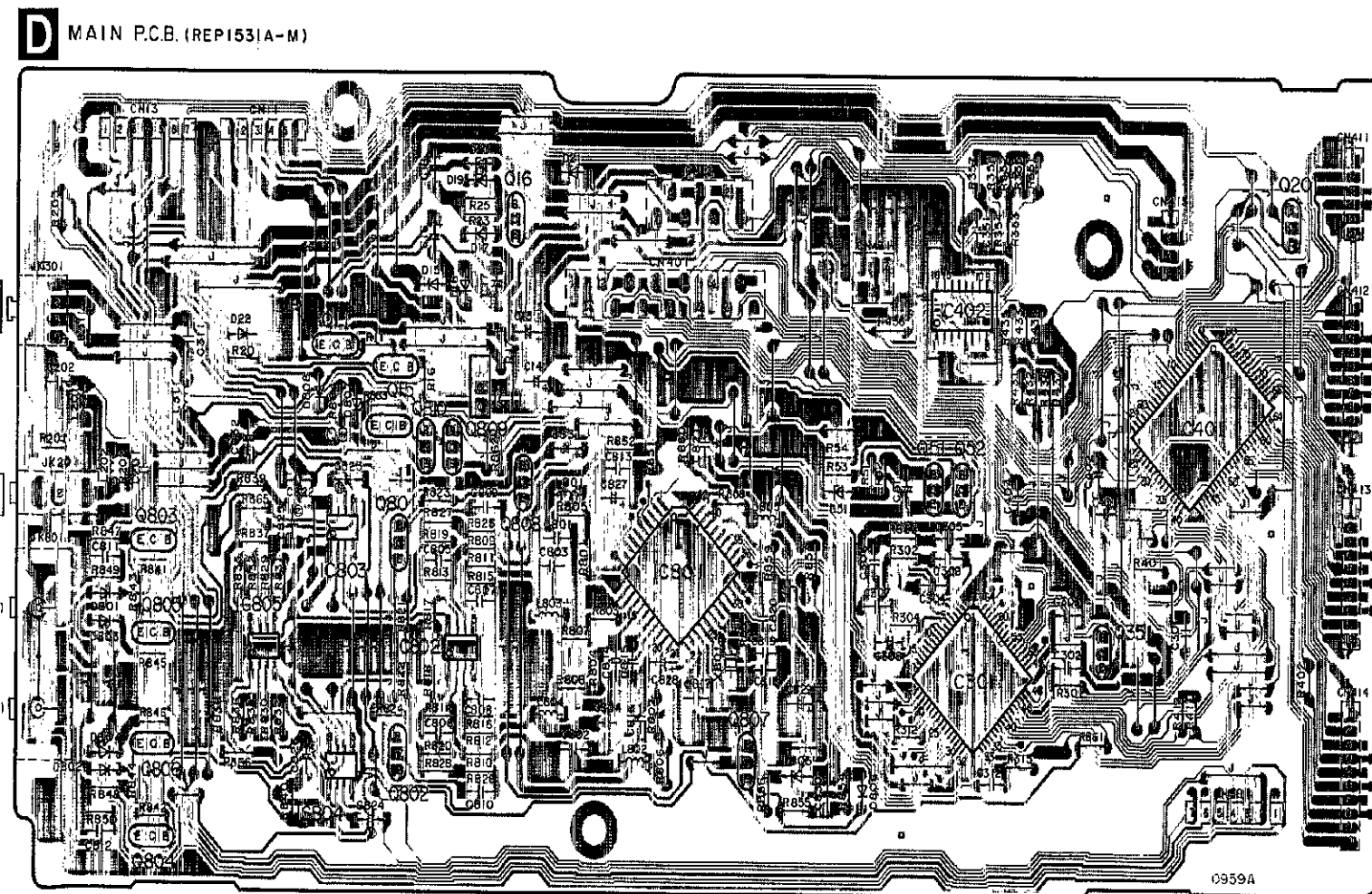
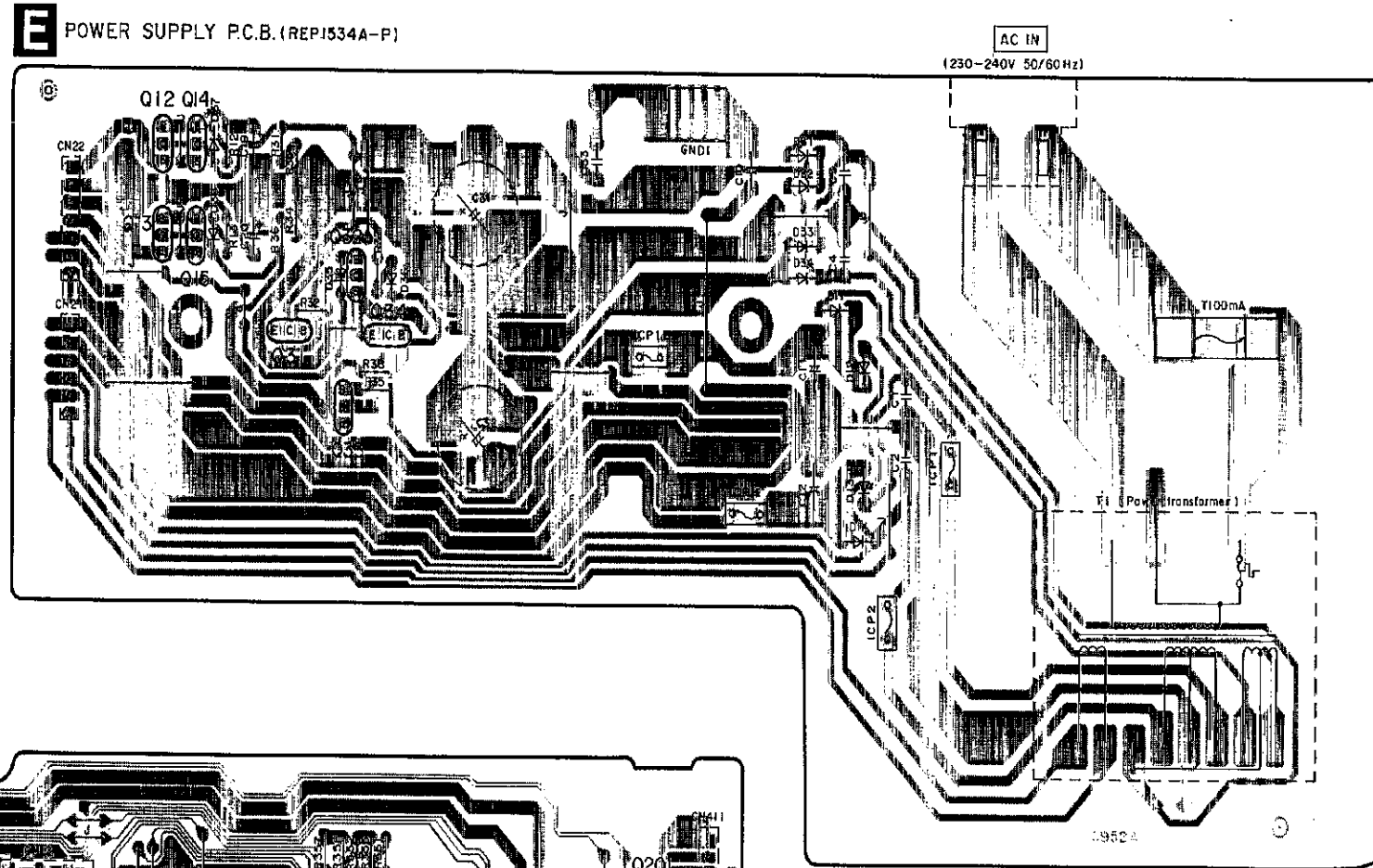
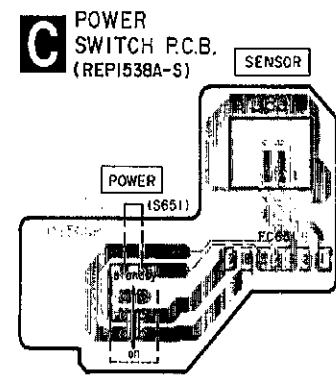
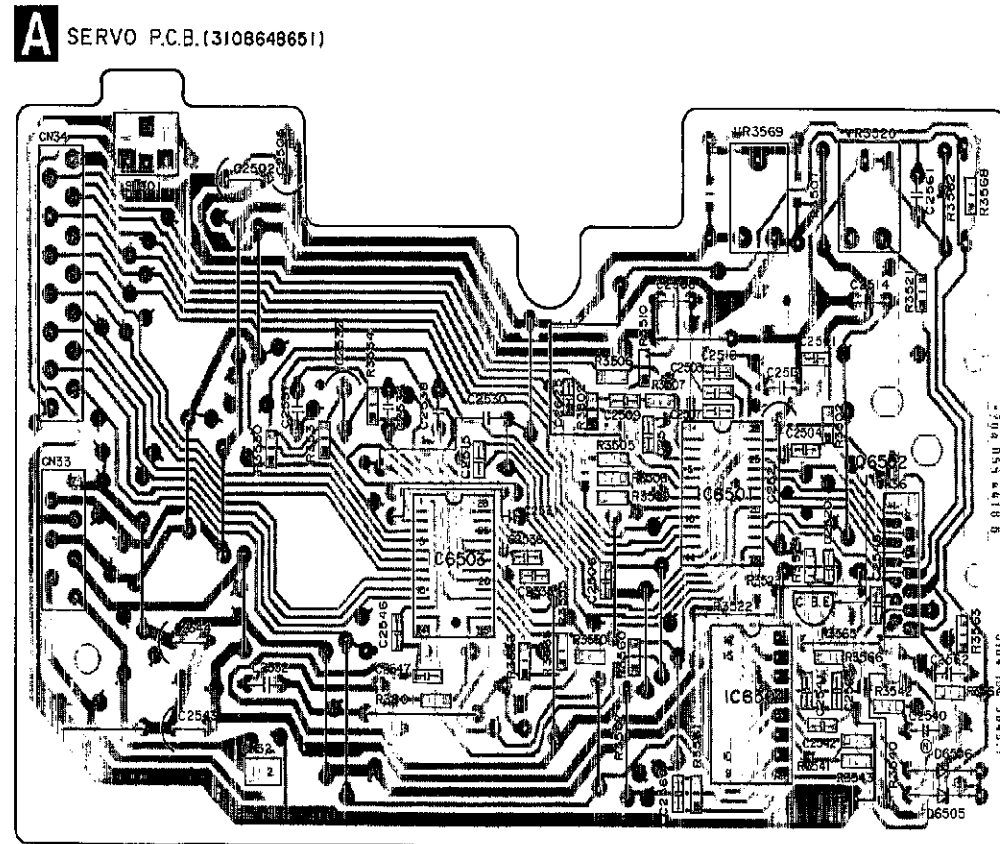

Terminal guide of IC's, transistors and diodes

 BA4550FT1	 LM833M63 8 Pin TCA0372DM2R 16 Pin	 48220972587 (TDA8808T) 48220973235 (TDA8809T)	 48220972587 (TCA0372DP2)
 MN6474E 42 Pin MN6626 64 Pin LUPD78043G015 80 Pin	 BA4560N	 LM2940T5M 1. Vin 2. GND 3. Vout	 RCDHC-237
 DTA114ESTP DTA124ESTP DTC124ESTP	 2SA1309QRSTA 2SC3311QRSTA 2SD1450RSTTA	 482213044121 (BC338)	 1SS254TA Cathode Anode
 1D3-E Cathode Anode	 MA4039MTA MA4082MTA Cathode Anode	 MA4160MTA 482213030861 (HZ7C2) Cathode Anode	

■ WIRING CONNECTION DIAGRAM

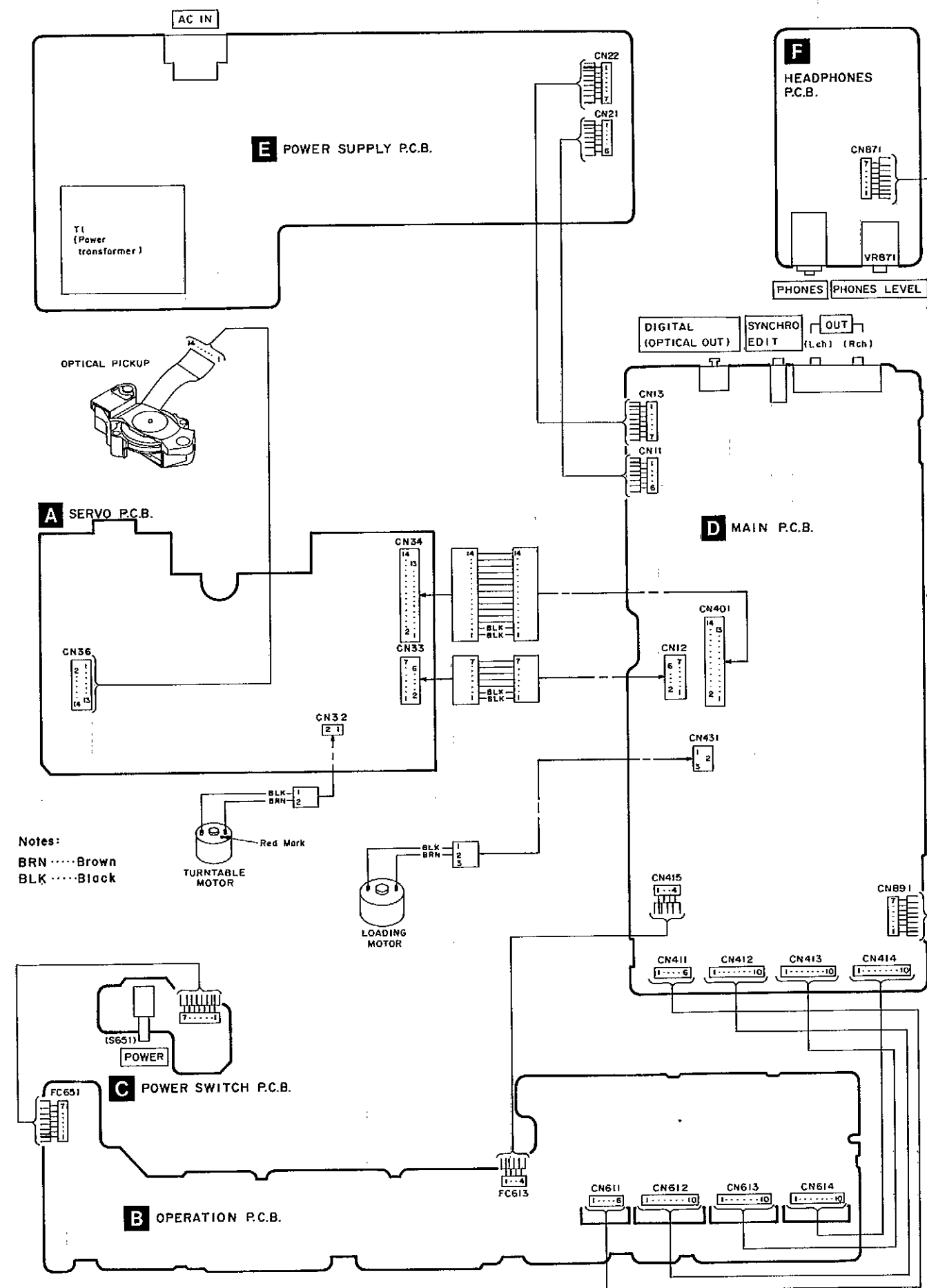

Notes:  
BRN.....Brown  
BLK.....Black

■ BLOCK DIAGRAM

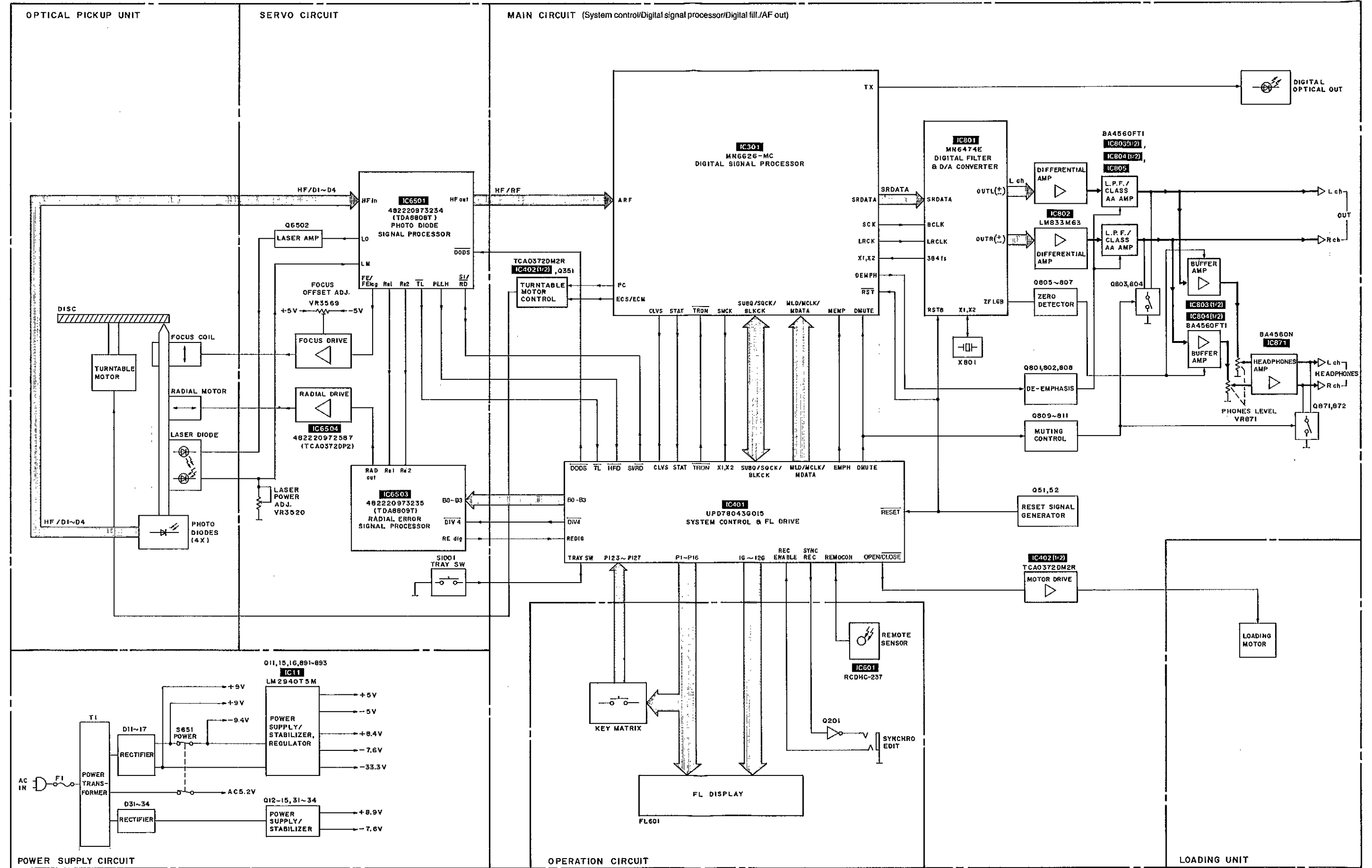

## FUNCTION OF IC TERMINALS

### • IC6501 (482220973234/TDA8808T): Photo diode signal processor

Pin No.	Mark	I/O Division	Function
1	GCHF	I	Gain control input of HF amplifier. Current output from HF amplitude detector
2	Vp	I	Positive supply voltage
3	HFout	O	HF amplifier and equalizer voltage output
4	DET	I	HF detector voltage input
5	Sc	I	Starting up capacitor input
6	SI/RD	I/O	On/off control (start input); ready signal output (starting up procedure successful)
7	Beg	I	Equalizer reference current input
8	Bgc	I	DC and LF gain control reference current input
9	FOC START	I	Focus normalizing circuit starting current
10	PLLH	O	PLL on hold output
11	TL	O	Track loss output
12	DODS	I	Drop out detector suppression input
13	Vext	I	Negative supply connection for FE and FEIag output stage; also substrate connection
14	LPF	O	Low pass filter for Iret, used in track loss (TL) detector and LF gain control

### • IC6503 (482220973235/TDA8809T): Radial error signal processor

Pin No.	Mark	I/O Division	Function
1	Vp	I	Positive supply voltage
2	Cosc1	I	Frequency setting capacitors for oscillator
3	Cosc2	I	
4	Rwob	I	Wobble generator input
5	Rosc	I	Biassing resistor for oscillator frequency and internal amplitude
6	DIV4	I	Radial error digital signal divided by four
7	REdig	O	Digital output of sign (Re2-Re1)
8	B3	I	Input control bits for off-, catch-, play-status and DAC output current
9	B2		
10	B1		
11	B0		
12	Vext (+)	I	Positive external voltage input
13	Vext (-)	I	Negative external voltage input (also substrate connection)
14	GND	I	GND terminal
15	RADout	O	Current output of amplified (Re2-Re1) input currents
16	REin	I	Radial error input
17	REIag	O	Voltage output of integrated (Re2-Re1) input currents

### • IC301 (MN6626): Digital signal processor

Pin No.	Mark	I/O Division	Function
1	AVSS	—	GND terminal
2	IREF	I	Reference current input
3	ARF	I	RF signal input
4	DRF	I	DSL bias terminal (Not used, open)
5	DSLIF	I/O	DSL loop filter terminal
6	PLLIF	I/O	PLL loop filter terminal
7	AVDD	I	Power supply terminal
8	RSEL	I	RF signal polarity setting terminal (Not used, connected to VDD)
9	TBUS7 TBUS0	O	Test terminal
16			
17	FLAG	O	Flag terminal
18	IPFLAG	O	Interpolation flag terminal
19	FCLK	O	Crystal frame clock (Not used, open)
20	BYTCK	O	Byte clock (Not used, open)
21	WDCK	O	Word clock (Not used, open)
22	RST	I	Reset terminal
23	TX	O	Digital audio signal (Not used, open)
24	LDG	O	Lch deglitch signal (Not used, open)
25	RDG	O	Rch deglitch signal (Not used, open)
26	SRDATA	O	Serial data output (MSB first)
27	SCK	O	Serial bit clock output
28	LRCK	O	L/R discriminating signal
29	XCK	O	Crystal OSC terminal (f=16.9344 MHz) (Not used, open)
30	PMCK	O	Frequency division clock signal (Not used, open) ( $f = \frac{1}{192} \times CK = 88.2 \text{ kHz}$ )
31	CSEL	I	Test terminal (Connected to GND)
32	PSEL		
33	X1	I	Crystal OSC terminal (f=16.9344 MHz)
34	X2	O	Crystal OSC terminal (f=16.9344 MHz)
35	VSS	—	GND terminal
36	SUBQ	O	Sub-code Q data
37	SQCK	I	Sub-code Q register clock
38	CLDCK	O	Sub-code frame clock (f=7.35 kHz) (Not used, open)

### • IC401 (UPD78043G015) System control & FL drive

Pin No.	Mark	I/O Division	Function
1	G7	O	FL grid signal
7	G1		
8	V <sub>DD</sub>	—	Power supply terminal
9	SQCK	O	Sub-code Q register clock
10	NC	—	Not connected
11	SUBQ	I	Sub-code Q data
12	OPEN/ CLOSE	O	Loading motor control signal H: OPEN, L: CLOSE
13	B3	I/O	Control bits for off-, catch-, play-status and DAC output current
16	B0		
17	RESET	I	Reset signal input
18	SI/RD	O	On/off control and ready signal
19	DIV4	O	Radial error digital signal divided by four
20	A.V <sub>SS</sub>	—	GND terminal
21	REC ENABLE	I	Synchro rec. control terminal
22	P16	I	Level meter selector
23	P15	I	Not connected
24	TRAY SW	I	Disc holder open/close det. terminal
25	P13	I	Not connected
27	P11		
28	HFD	I	PLL on hold input
29	A.V <sub>DD</sub>	I	Power supply terminal
30	A.V <sub>SS</sub>	I	Connected to GND
31	V <sub>SS</sub>	I	Not connected
32	NC		
33	V <sub>SS</sub>	—	GND terminal
34	X1	I	System clock input/output (f=4.2336 MHz)
35	X2	O	

Pin No.	Mark	I/O Division	Function
36	SYNC REC	O	Synchro rec. control terminal
37	DODS	O	Drop-out detect signal
38	CLVS	I	Spindle servo phase synchro signal ("H": CLV, "L": Rough servo)
39	TRON	O	Tracking servo ON signal ("L": ON)
40	RE DIG	I	Radial error digital
41	MDATA	O	IC (MN6626) command data signal
42	MCLK	O	IC (MN6626) command clock signal
43	MLD	O	IC (MN6626) command load signal
44	BLKCK	I	Sub-code block clock
45	TL	I	Track loss input
47	REMOCON	I	Remote control signal
48	V <sub>SS</sub>	—	Connected to GND
49	STAT	I	Status signal (CRC, CUE, CLVS, TTSTOP, FCLV, SQOK)
50	DMUTE	O	Muting output ("H": MUTE)
51	EMPH	O	Emphasis signal ("H": EMPHASIS ON)
52	V <sub>DD</sub>	—	Power supply terminal
53	P127	I	Key return signal
57	P123		
58	P122	—	Not connected
59	P16	O	FL segment signal and key scan signal
70	P5		
71	V <sub>DD</sub>	I	Power Supply terminal for FL drive
72	P4	O	FL segment signal
75	P1		
76	12G	O	FL grid signal
80	8G		



## • IC801 (MN6474E): Digital filter and D/A converter

Pin No.	Mark	I/O Division	Function
1	MLD	I	Command load input (load: L) (Not used, connected to VDD)
2	RSTB	I	Reset terminal
3	IE	I	Not used, connected to GND
4	TP1	—	TEST terminal
5	TP2	—	
6	TEST1	I	TEST terminal 1 (connected to GND)
7	TEST2	I	TEST terminal 2 (connected to GND)
8	NC	—	Not connected
9	NC	—	Not connected
10	AVDD4	I	Power supply terminal
11	OUTL (-)	O	Lch data output, (-) terminal
12	AVSS4	—	GND terminal
13	AVSS3	—	GND terminal
14	OUTL (+)	O	Lch data output, (+) terminal
15	AVDD3	I	Power supply terminal
16	NC	—	Not connected
17	AVDD2	I	Power supply terminal
18	OUTR (+)	O	Rch data output, (+) terminal
19	AVSS2	—	GND terminal (analog system)
20	AVSS1	—	GND terminal (analog system)
21	OUTR (-)	O	Rch data output, (-) terminal
22	AVDD1	I	Power supply terminal
23	DVDD1	I	Power supply terminal

Pin No.	Mark	I/O Division	Function
24	DVSS1	—	GND terminal (digital system)
25	X2	O	Crystal OSC terminal (33MHz)
26	X1	I	
27	NC	—	Not connected
28	DVDD2	I	Power supply terminal
29	DVSS2	—	GND terminal (digital system)
30	NSUB	I	Sub-strate terminal (Not used, connected to VDD)
31	ZFLGB	O	Zero input detector terminal (Not used, open)
32	192fs	O	192fs (8.4672 MHz) (Not used, open)
33	LRPOL	I	LR clock selector (Not used, connected to VDD)
34	LRCLK	I	LR discrimination signal input
35	BCLK	I	Serial bit clock input
36	SRDATA	I	Serial data input (MSB first)
37	DVSS3	—	GND terminal (digital system)
38	DVDD	I	Power supply terminal
39	384fs	O	384fs (16.9344 MHz) output
40	PD	I	Power down terminal (Not used, connected to GND)
41	MDATA	I	Mode control data (Not used, connected to VDD)
42	MCLK	I	Data clock for MDATA (not used, connected to VDD)

# REPLACEMENT PARTS LIST

**Notes:** \*Important safety notice:

 Components identified by  $\Delta$  mark have special characteristics important for safety.

Furthermore, special parts which have purposes of fire-retardant (resistors), high-quality sound (capacitors), low-noise (resistors), etc. are used.

When replacing any of components, be sure to use only manufacturer's specified parts shown in the parts list.

\*The parenthesized indications in the Remarks columns specify the areas. (Refer to the cover page for area.)

Parts without these indications can be used for all areas.

\*Remote Control Ass'y:

Supply period for three years from termination of production.

\* [MB] Indicates in Remarks columns parts that are supplied by MBV.

\*Warning: This product uses a laser diode. Refer to caution statements on pages 2, 3.

\*ACHTUNG: Die Lasereinheit nicht zerlegen.

Die Lasereinheit darf nur gegen eine vom Hersteller spezifizierte Einheit ausgetauscht werden.

Ref. No.	Part No.	Part Name & Description	Remarks	Ref. No.	Part No.	Part Name & Description	Remarks
		INTEGRATED CIRCUIT(S)		D19, 20	MA4160M	DIODE	$\Delta$
				D21	MA4082MTA	DIODE	$\Delta$
				D22	1SS254TA	DIODE	
IC11	LM2940T5	I. C, REGULATOR	$\Delta$	D31-34	1D3-E	DIODE	$\Delta$ [MB]
IC301	MN6626	I. C, DIG. SIG. PROCESSOR		D35	MA4039MTA	DIODE	$\Delta$
IC401	UPD78043G015	I. C, SYS. CONTROL&FL DRIVE	[MB]	D36-38	1SS254TA	DIODE	
IC402	TCA0372DM2R	I. C, MOTOR DRIVE		D51	MA4039MTA	DIODE	
IC601	RCDHC-237	I. C, REMOTE CONTROL RECEIVER		D601-608	1SS254TA	DIODE	
IC801	MN6474E	I. C, FILTER & D/A CONVERTER		D801-806	1SS254TA	DIODE	
IC802	LM833MG3	I. C, DIFFERENTIAL AMP.		D807	1D3-E	DIODE	[MB]
IC803-805	SVIBA4560FT1	I. C, L. P. FILTER AMP.		D808	1SS254TA	DIODE	
IC871	BA4560N	I. C, HEADPHONES AMP.		D891	1SS254TA	DIODE	
		IC PROTECTOR(S)				VARIABLE RESISTOR(S)	
ICP1, 2	SRUN38T	IC PROTECTOR	$\Delta$	VR871	EVJCEFA5A15	V. R, HEADPHONES	[MB]
ICP11, 12	SRUN15	IC PROTECTOR	$\Delta$			COIL(S)	
		TRANSISTOR(S)		L201, 202	RLQZN3R3KL-D	COIL	[MB]
Q11	2SA1309A-R	TRANSISTOR		L311	RLQZN1R0KL-D	COIL	
Q12	2SC3311A-Q	TRANSISTOR		L801-804	RLQZN471KL-D	COIL	[MB]
Q13	2SA1309A-R	TRANSISTOR		L805	RLQZN4R7KL-D	COIL	
Q14	2SC3311A-Q	TRANSISTOR		L871-873	RLQZN3R3KL-D	COIL	[MB]
Q15	2SA1309A-R	TRANSISTOR		L874	RLQZN4R7KL-D	COIL	
Q16	2SB1238QSTV6	TRANSISTOR	$\Delta$			TRANSFORMER(S)	
Q31	2SA1309A-R	TRANSISTOR		T1	RTP1K4B008	POWER TRANSFORMER	$\Delta$ [MB]
Q32	DTC124EST	TRANSISTOR				OSCILLATOR(S)	
Q33, 34	2SA1309A-R	TRANSISTOR		X801	RSXA33M8J01T	OSCILLATOR (33MHz)	[MB]
Q51, 52	2SC3311A-Q	TRANSISTOR				DISPLAY	
Q201	DTC124EST	TRANSISTOR		FL601	RSL0146-F	FL DISPLAY	[MB]
Q351	DTA124ESTP	TRANSISTOR				SWITCH(ES)	
Q801, 802	2SC3311A-Q	TRANSISTOR		S601	EVQ21405R	SW, 0	
Q803, 804	2SD1450RTA	TRANSISTOR		S602	EVQ21405R	SW, 1	
Q805, 806	2SC3311A-Q	TRANSISTOR		S603	EVQ21405R	SW, 2	
Q807-809	DTA124ESTP	TRANSISTOR		S604	EVQ21405R	SW, 3	
Q810	DTC124EST	TRANSISTOR		S605	EVQ21405R	SW, 4	
Q811	DTA114ESTP	TRANSISTOR				DIODE(S)	
Q871, 872	2SD1450RTA	TRANSISTOR		D11-17	1D3-E	DIODE	$\Delta$ [MB]
Q891	2SC3311A-Q	TRANSISTOR					
Q892, 893	2SA1309A-R	TRANSISTOR					

Ref. No.	Part No.	Part Name & Description	Remarks	Ref. No.	Part No.	Part Name & Description	Remarks
S606	EVQ21405R	SW, 5		GND601	SUSD144	EARTH PLATE	
S607	EVQ21405R	SW, >10		GND871	RMC0184	EARTH PLATE	[MB]
S608	EVQ21405R	SW, 10				JACK(S)	
S609	EVQ21405R	SW, 9					
S610	EVQ21405R	SW, 8					
S611	EVQ21405R	SW, 7		JK201	RJJ33T01	JACK, SYNCHRO EDIT	
S612	EVQ21405R	SW, 6		JK301	TOTX174-A	JACK, OPTICAL OUT	
S613	EVQ21405R	SW, PLAY		JK801	RJH3201N	JACK, LINE OUT	
S614	EVQ21405R	SW, R. SKIP		JK871	QJA0455ZC-A	JACK, HEADPHONES	
S615	EVQ21405R	SW, R. SEARCH				FUSE	
S616	EVQ21405R	SW, PROGRAM					
S617	EVQ21405R	SW, DISC LINK		F1	XBA2C01TBO	FUSE, 250V T100mA	△
S618	EVQ21405R	SW, LEVEL METER				<SERVO P. C. B. >	
S619	EVQ21405R	SW, STOP				INTEGRATED CIRCUIT(S)	
S620	EVQ21405R	SW, F. SKIP					
S621	EVQ21405R	SW, F. SEARCH		IC6501	482220973234	I. C. PHOTO DIODE S. P.	[MB]
S622	EVQ21405R	SW, RECALL		IC6503	482220973235	I. C. RADIAL ERROR S. P.	[MB]
S623	EVQ21405R	SW, SIDE A/B		IC6504	482220972587	I. C. FOCUS/RADIAL DRIVE	[MB]
S624	EVQ21405R	SW, RANDOM				TRANSISTOR(S)	
S625	EVQ21405R	SW, T. FADE		Q6502	482213044121	TRANSISTOR	[MB]
S626	EVQ21405R	SW, OPEN/CLOSE				DIODE(S)	
S627	EVQ21405R	SW, PAUSE					
S628	EVQ21405R	SW, REPEAT		D6505	482213030861	DIODE	[MB]
S629	EVQ21405R	SW, CLEAR		D6506	482213030861	DIODE	[MB]
S630	EVQ21405R	SW, TAPE LENGTH				VARIABLE RESISTOR(S)	
S631	EVQ21405R	SW, TIME MODE		VR3520	482210110685	V. R. LASER POWER ADJ.	[MB]
S632	EVQ21405R	SW, PEAK SEARCH		VR3569	482210011193	V. R. FOCUS OFFSET ADJ.	[MB]
S633	EVQ21405R	SW, LEVEL UP				SWITCH	
S634	EVQ21405R	SW, LEVEL DOWN					
S635	EVQ21405R	SW, AUTO CUE		S1001	482227612523	SW, TRAY	[MB]
S651	RSP2B010	SW, POWER	△			CONNECTOR(S)	
		CONNECTOR(S)					
CN11	RJS1A6606	SOCKET(6P)					
CN12	RJT001H007	CONNECTOR(7P)	[MB]				
CN13	RJS1A6607T1	SOCKET(7P)	[MB]				
CN21	RJS1A6606	SOCKET(6P)					
CN22	RJS1A6607T1	SOCKET(7P)	[MB]				
CN401	RJT001H014	CONNECTOR(14P)	[MB]				
CN411	RJU003K006M1	SOCKET(6P)					
CN412-414	RJU003K010M1	SOCKET(10P)		CN32	310410725084	CONNECTOR(2P)	[MB]
CN415	RJS1A6604	SOCKET(4P)		CN33	RJT001H007	CONNECTOR(7P)	[MB]
CN431	RJT001H003	CONNECTOR(3P)	[MB]	CN34	RJT001H014	CONNECTOR(14P)	[MB]
CN611	RJT003K006M1	CONNECTOR(6P)		CN36	482226750676	CONNECTOR(14P)	[MB]
CN612-614	RJT003K010M1	CONNECTOR(10P)					
CN871	RJS1A6607T1	SOCKET(7P)	[MB]				
CN891	RJS1A6607T1	SOCKET(7P)	[MB]				
		EARTH TERMINAL(S)					
GND1	SUSD144	EARTH PLATE					

Notes : \* Capacity values are in microfarads (uF) unless specified otherwise, P=Pico-farads (pF) F=Farads (F)  
\* Resistance values are in ohms, unless specified otherwise, 1K=1,000 (OHM) , 1M=1,000k (OHM)

Ref. No.	Part No.	Values & Remarks	Ref. No.	Part No.	Values & Remarks	Ref. No.	Part No.	Values & Remarks
		RESISTORS	R819, 820	ERDS2TJ511	1/4W 510	C33	ECFR1E104ZF5	25V 0.1U
			R821, 822	ERDS2TJ105T	1/4W 1M	C51	ECEA1AKA220B	10V 22U
			R823, 824	ERDS2TJ222	1/4W 2.2K	C201, 202	ECBT1C103NS5	16V 0.01U
R11	ERDS2TJ182	1/4W 1.8K	R825, 826	ERDS2TJ270T	1/4W 27	C301	ECBT1C103NS5	16V 0.01U
R12, 13	ERDS2TJ102	1/4W 1K	R827, 828	ERDS2TJ181T	1/4W 180	C302	ECBT1H270J5	50V 27P
R16, 17	ERDS2TJ103	1/4W 10K	R829, 830	ERDS2TJ101	1/4W 100	C303, 304	ECFR1E104ZF5	25V 0.1U
R20	ERDS2TJ102	1/4W 1K	R831, 832	ERDS2TJ331	1/4W 330	C305	ECBT1H102KB5	50V 1000P
R23	ERDS2TJ222	1/4W 2.2K	R833, 834	ERDS2TJ103	1/4W 10K	C306	ECFR1E223KB	25V 0.022U
R25	ERDS2TJ222	1/4W 2.2K	R835, 836	ERDS2TJ333	1/4W 33K	C307	ECQV1H474JM3	50V 0.47U
R31	ERDS2TJ221	1/4W 220	R837, 838	ERDS2TJ472	1/4W 4.7K	C308	ECBT1H102KB5	50V 1000P
R32	ERDS2TJ103	1/4W 10K	R839, 840	ERDS2TJ331	1/4W 330	C309	ECFR1E104ZF5	25V 0.1U
R33, 34	ERDS2TJ221	1/4W 220	R841, 842	ERDS2TJ102	1/4W 1K	C311	ECFR1E104ZF5	25V 0.1U
R35	ERDS2TJ102	1/4W 1K	R843, 844	ERDS2TJ181T	1/4W 180	C312	ECBT1C103NS5	16V 0.01U
R36	ERDS2TJ221	1/4W 220	R845, 846	ERDS2TJ563	1/4W 56K	C351	ECBT1H102KB5	50V 1000P
R37	ERDS2TJ103	1/4W 10K	R847, 848	ERDS2TJ271	1/4W 270	C401	ECFR1E104ZF5	25V 0.1U
R38	ERDS2TJ822	1/4W 8.2K	R849, 850	ERDS2TJ473	1/4W 47K	C402	ECEA0JKA470B	6.3V 47U
R51	ERDS2TJ331	1/4W 330	R851, 852	ERDS2TJ470	1/4W 47	C404	ECFR1E104ZF5	25V 0.1U
R52	ERDS2TJ272T	1/4W 2.7K	R853	ERDS2TJ472	1/4W 4.7K	C651, 652	ECBT1C102KB	16V 1000P
R53, 54	ERDS2TJ472	1/4W 4.7K	R854	ERDS2TJ223	1/4W 22K	C801-804	ECQV1H683JM3	50V 0.068U
R201	ERDS2TJ100	1/4W 10	R855-857	ERDS2TJ102	1/4W 1K	C805-808	ECBT1H121KB5	50V 120P
R202	ERDS2TJ102	1/4W 1K	R858	ERDS2TJ101	1/4W 100	C809, 810	ECQV1H683JM3	50V 0.068U
R203	ERDS2TJ273	1/4W 27K	R859, 860	ERDS2TJ100	1/4W 10	C811, 812	ECBT1H102KB5	50V 1000P
R301	ERDS2TJ182	1/4W 1.8K	R861	ERDS2TJ102	1/4W 1K	C813-817	ECFR1E104ZF5	25V 0.1U
R302	ERDS2TJ823T	1/4W 82K	R862	ERDS2TJ472	1/4W 4.7K	C818, 819	ECBT1H5R6K5	50V 5.6P
R303	ERDS2TJ104	1/4W 100K	R863	ERDS2TJ471	1/4W 470	C820-822	ECFR1E104ZF5	25V 0.1U
R304	ERDS2TJ471	1/4W 470	R864	ERDS2TJ222	1/4W 2.2K	C823, 824	ECEA1CN330S	16V 33U
R311	ERDS2TJ822	1/4W 8.2K	R865, 866	ERDS2TJ472	1/4W 4.7K	C825, 826	ECEA1CN220B	16V 22U
R312	ERDS2TJ331	1/4W 330	R871, 872	ERDS2TJ473	1/4W 47K	C827, 828	ECEA0JU331B	6.3V 330U
R315	ERDS2TJ104	1/4W 100K	R873, 874	ERDS2TJ123	1/4W 12K	C829	ECEA0JKA101B	6.3V 100U
R351	ERDS2TJ103	1/4W 10K	R875, 876	ERDS2TJ104	1/4W 100K	C830	ECEA1EKA4R7B	25V 4.7U
R352	ERDS2TJ104	1/4W 100K	R885, 886	ERDS2TJ222	1/4W 2.2K	C831	ECEA1CKA100B	16V 10U
R353	ERDS2TJ123	1/4W 12K	R887, 888	ERDS2TJ680T	1/4W 68	C832	ECEA0JU471	6.3V 470U
R354	ERDS2TJ104	1/4W 100K	R889, 890	ERDS2TJ472	1/4W 4.7K	C871, 872	ECEA1EKN3R3B	25V 3.3U
R355, 356	ERDS2TJ333	1/4W 33K	R891, 892	ERDS2TJ102	1/4W 1K	C873, 874	ECQB1H103JF3	50V 0.01U
R357	ERD25FJ6R8	1/4W 6.8 △	R897	ERDS2TJ103	1/4W 10K	C875-879	ECBT1C103NS5	16V 0.01U
R401	ERDS2TJ104	1/4W 100K	R898	ERDS2TJ822	1/4W 8.2K	C881, 882	ECEA1AN101KB	10V 100U
R402	ERDS2TJ473	1/4W 47K				C891	ECEA1CKA101B	16V 100U
R411, 412	ERDS2TJ472	1/4W 4.7K				C892	ECBT1C103NS5	16V 0.01U
R431, 432	ERDS2TJ223	1/4W 22K				C895	ECBT1C103NS5	16V 0.01U
R433	ERDS2TJ104	1/4W 100K	C1-4	ECFTD103KXL	50V 0.01U			
R434	ERDS2TJ224T	1/4W 220K	C10	ECFR1E104ZF5	25V 0.1U			<SERVO P. C. B. >
R435	ERDS2TJ104	1/4W 100K	C11	ECA1CM222B	16V 2200U △			RESISTORS
R436	ERDS2TJ224T	1/4W 220K	C12	ECA1CM222B	16V 2200U △			
R437, 438	ERDS2TJ223	1/4W 22K	C14, 15	ECEA0JKA470B	6.3V 47U	R3501	482205024702	1/8W 4.7K [MB]
R801-804	ERDS2TJ330	1/4W 33	C16	ECEA1EU101	25V 100U	R3502	482205110104	1/8W 100K [MB]
R805-808	ERDS2TJ2R2T	1/4W 2.2	C17, 18	ECEA1HU101	50V 100U	R3505	482205110123	1/4W 12K [MB]
R809-812	ERDAS3G433T	1/4W 43K [MB]	C19, 20	ECEA1CKA101B	16V 100U	R3506	482205110101	1/8W 100 [MB]
R813-816	ERDAS3G563T	1/4W 56K	C31	ECCE1CV332RZ	16V 3300U △ [MB]	R3507	482205120222	1/8W 2.2K [MB]
R817, 818	ERDS2TJ472	1/4W 4.7K	C32	ECCE1CV332RZ	16V 3300U △ [MB]	R3508	482205110243	1/4W 24K [MB]

Note: The "(SF)" mark denotes the standard part.  
 \*[MB]: indicates parts that are supplied by MBV.  
 [VRD]: indicates parts that are supplied by Video Recorder Division.

Ref. No.	Part No.	Values & Remarks	Ref. No.	Part No.	Values & Remarks	Ref. No.	Part No.	Values & Remarks
R3509	482205110562	1/8W 5.6K [MB]	R3567	482205028203	1/8W 82K [MB]	C2520	482212231965	63V 220P [MB]
R3510	482205110103	1/8W 10K [MB]	R3568	482205110474	1/4W 470K [MB]	C2521	482212422027	25V 47U [MB]
R3521	482205110221	1/8W 220 [MB]			CHIP JUMPER(S)	C2530	482212151321	63V 8200P [MB]
R3522	482205210229	1/3W 22 [MB]				C2531	482212151321	63V 8200P [MB]
R3523	482205210129	1/3W 12 [MB]				C2532	482212440272	16V 33U [MB]
R3524	482205110101	1/8W 100 [MB]	R3801	482205110008	JUMPER [MB]	C2534	532212142661	63V 0.33U [MB]
R3530	482205110473	1/4W 47K [MB]	R3802	482205110008	JUMPER [MB]	C2535	482212231981	50V 0.033U [MB]
R3531	482205110153	1/4W 15K [MB]				C2536	482212231981	50V 0.033U [MB]
R3533	482205110152	1/4W 5.1K [MB]			CAPACITORS	C2537	482212143375	63V 0.22U [MB]
R3534	482205110224	1/8W 220K [MB]				C2538	482212143375	63V 0.22U [MB]
R3535	482205021203	3/5W 12K [MB]	C2501	482212232863	50V 0.022U [MB]	C2540	482212441583	50V 0.68U [MB]
R3540	482205024708	3/5W 4.7 [MB]	C2502	482212440433	25V 47U [MB]	C2541	482212232863	50V 0.022U [MB]
R3541	482205110682	1/4W 6.8K [MB]	C2503	482212232863	50V 0.022U [MB]	C2542	482212232863	50V 0.022U [MB]
R3542	482205110829	1/8W 82 [MB]	C2504	482212231727	63V 470P [MB]	C2543	482212440196	16V 220U [MB]
R3543	482205110682	1/8W 6.8K [MB]	C2505	482212440433	25V 47U [MB]	C2544	482212440196	16V 220U [MB]
R3550	482205110182	1/4W 1.8K [MB]	C2506	482212233496	63V 0.1U [MB]	C2545	482212233496	63V 0.1U [MB]
R3555	482205110183	1/4W 18K [MB]	C2507	482212231644	63V 2200P [MB]	C2546	482212233496	63V 0.1U [MB]
R3560	482211191494	1/8W 11K [MB]	C2508	532212142491	100V 0.047U [MB]	C2547	482212232863	50V 0.022U [MB]
R3561	482205110154	1/4W 150K [MB]	C2509	482212231772	50V 47P [MB]	C2552	482212143526	100V 0.047U [MB]
R3562	482205021204	3/5W 120K [MB]	C2510	482212232442	50V 0.01U [MB]	C2560	482212231784	50V 4700P [MB]
R3563	482205110563	1/8W 56K [MB]	C2511	482212231746	50V 1000P [MB]	C2561	482212151252	63V 0.47U [MB]
R3564	482211191495	1/8W 160K [MB]	C2513	482212143375	63V 0.22U [MB]	C2562	532212142661	63V 0.33U [MB]
R3565	482205210279	1/3W 27 [MB]	C2514	482212151252	63V 0.47U [MB]	C2563	482212233496	63V 0.1U [MB]
R3566	482205110229	1/8W 22 [MB]	C2515	482212231746	50V 1000P [MB]	C2625	482212231765	50V 100P [MB]

PACKAGING

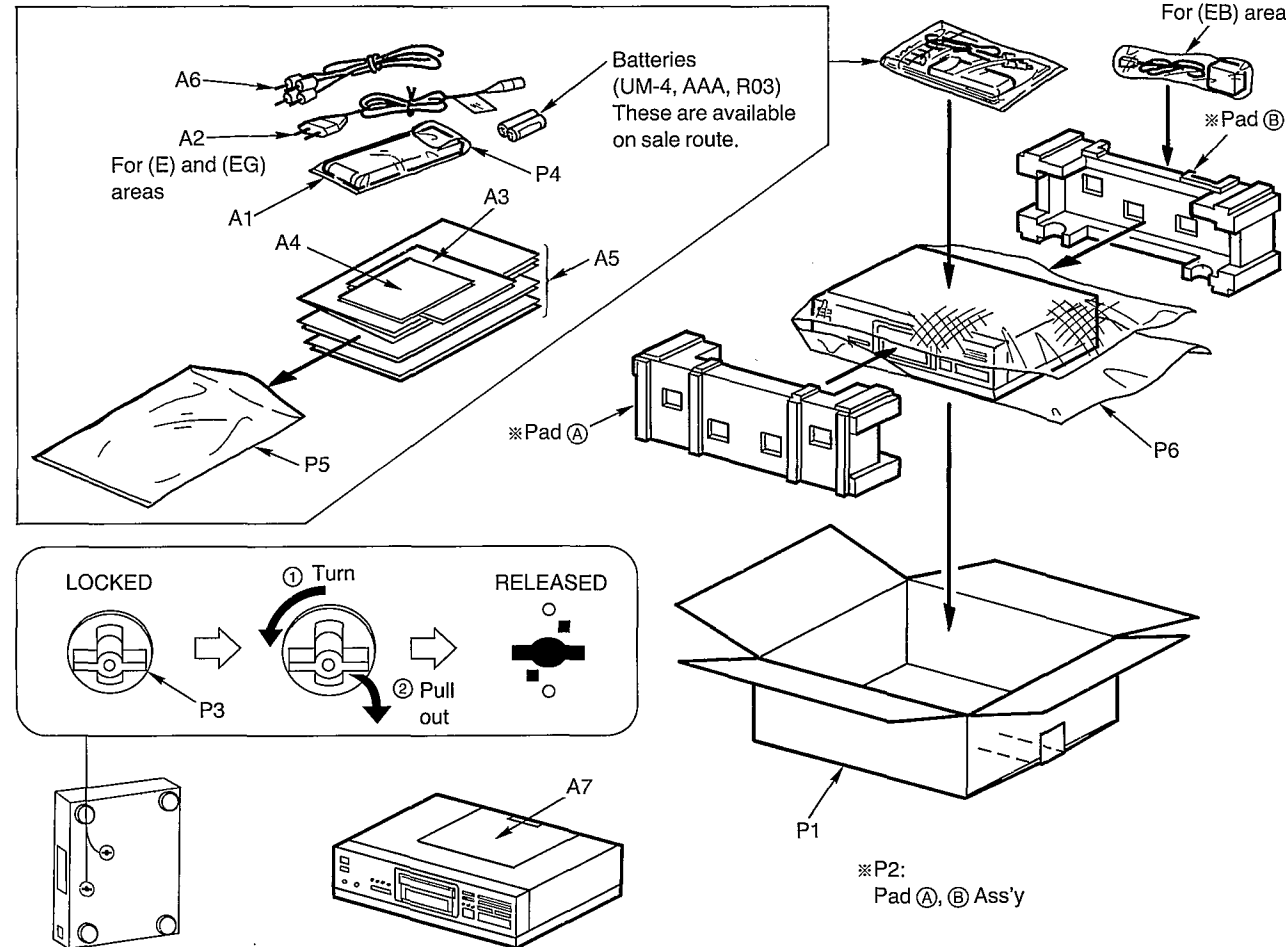

Ref. No.	Part No.	Part Name & Description	Remarks	Ref. No.	Part No.	Part Name & Description	Remarks
		CABINET PARTS		106	482235810115	DRIVE BELT	[MB]
1	RK0152-K	CABINET	[MB]	107	482252232359	WHEEL, GEAR	[MB]
2	SNE2129-1	SCREW		108	482253251518	RING, RUBBER	[MB]
3	XTBS3+8JFZ1	SCREW		109	482240261081	GUIDE	[MB]
4	RFKHLPS740AE	REAR PANEL	(E, EG) [MB]	111	482240261132	GUIDE	[MB]
4	RFKHLPS740AB	REAR PANEL	(EB) [MB]	112	482252890638	ROLLER	[MB]
5	EYF52BC	FUSE HOLDER		113	482249251902	SPRING, COMPRES.	[MB]
6	RGK0537-K	TRAY LID	[MB]	114	482246661587	FOAM	[MB]
7	RKA0040B	FOOT	[MB]	116	482240261107	LEVER	[MB]
8	RMK0146-1	BOTTOM BOARD	[MB]	117	482249263659	SPRING, BLADE	[MB]
9	RMRO020	SPACER (A)	[MB]	118	482244460568	DISC LID	[MB]
10	RMRO021	SPACER (B)	[MB]	119	482249232883	SPRING, TENSION	[MB]
11	RMRO377-1	PCB SUPPORT	[MB]	121	482252890639	ROLLER	[MB]
12	RMRO573-K1	SPACER (C)	[MB]	122	482246692257	PLATE	[MB]
13	RWJ6406110XX	FLAT CABLE (6P)	[MB]	123	482240261207	HOLDER	[MB]
14	RMRO658-K	FL HOLDER	[MB]	124	482252040177	SMALL BALL	[MB]
15	RGU0809-K	BUTTON, POWER	[MB]	126	482253080503	RING, PRESSURE	[MB]
16	RGW0048	KNOB, H. P. VOLUME	[MB]	127	482269130209	OPTICAL PICKUP UNIT	[MB]
17	RMRO657-K	H. P. PCB HOLDER	[MB]	128	482240261196	SUPPORT	[MB]
18	RWJ6407110XX	FLAT CABLE (7P)	[MB]	129	482249263746	CLAMPING SPRING	[MB]
19	XTB3+20JFZ	SCREW		131	482236120998	LOADING MOTOR	[MB]
20	XTB3+35JFZ	SCREW		132	482240250244	BRACKET	[MB]
21	REX0285	FLAT CABLE (14P)	[MB]	133	482249251935	SPRING, COMPRES.	[MB]
22	XTB3+8GFZ	SCREW		134	482270112729	CHASSIS	[MB]
24	RYP0399Z-K	FRONT PANEL ASS'Y	[MB]	135	251107650014	SCREW	[MB]
24-1	RGU0873-K	BUTTON, PLAY etc.	[MB]			PACKING MATERIALS	
24-2	RGU0874A-K	BUTTON, DISC LINK etc.	[MB]	P1	RP61373	PACKING CASE	[MB]
24-3	RKWO264A-R	FL PANEL	[MB]	P2	RPNO670	PAD	[MB]
24-4	RKWO265-B	FILTER	[MB]	P3	RMRO024	LOCK SHAFT	[MB]
25	XTBS26+8J	SCREW		P4	XZB26X17C03	PROTECTION COVER (REMOCON)	
27	REX0007	FLAT CABLE (7P)	[MB]	P5	XZB23X35C03	PROTECTION COVER (F. B.)	
28	SJS9236	AC INLET	△	P6	XZB60X65A01Z	PROTECTION COVER (UNIT)	
29	RWJ6407480XX	FLAT CABLE (7P)	[MB]			ACCESSORIES	
30	RGK0510-T	ORNAMENT RUBBER		A1	EUR642100	REMOTE CONTROL TRANSMITTER	[MB]
31	RKWO048-K	BOTTOM BASE	[MB]	A1-1	UR64EC1326	BATTERY COVER	[MB]
32	RWJ6404180XX	FLAT CABLE (4P) (FC613)	[MB]	A2	RJA0019-2K	AC POWER SUPPLY CORD	△ (E, EG) (SF) [VRD]
33	RWJ6407150XX	FLAT CABLE (7P) (FC651)	[MB]	A2	VJA0733	AC POWER SUPPLY CORD	△ (EB) (SF) [VRD]
34	RQLS0022	LASER CAUTION LABEL	[MB]	A3	RQA0013	WARRANTY CARD	
35	RQLS0074	LASER CAUTION LABEL	[MB]	A4	RQCB0169	SERVICE CENTER LIST	
36	XTB3+8JFZ	SCREW		A5	RFKSLPS740AE	INSTRUCTIONS MANUAL	(E) [MB]
		LOADING UNIT PARTS		A5	RQT1669-B	INSTRUCTIONS MANUAL	(EB) [MB]
101	482244450603	DISC HOLDER	[MB]	A5	RFKSLPS740AG	INSTRUCTIONS MANUAL	(EG) [MB]
102	482232550176	GROMMET, CABLE	[MB]	A6	SJP2249-3	STEREO CONNECTION CABLE	
103	482232550177	GROMMET, CABLE	[MB]	A7	RQCA0059	LOCK CAUTION SHEET	[MB]
104	482246692251	DISC TRAY	[MB]				

# CABINET PARTS LOCATION

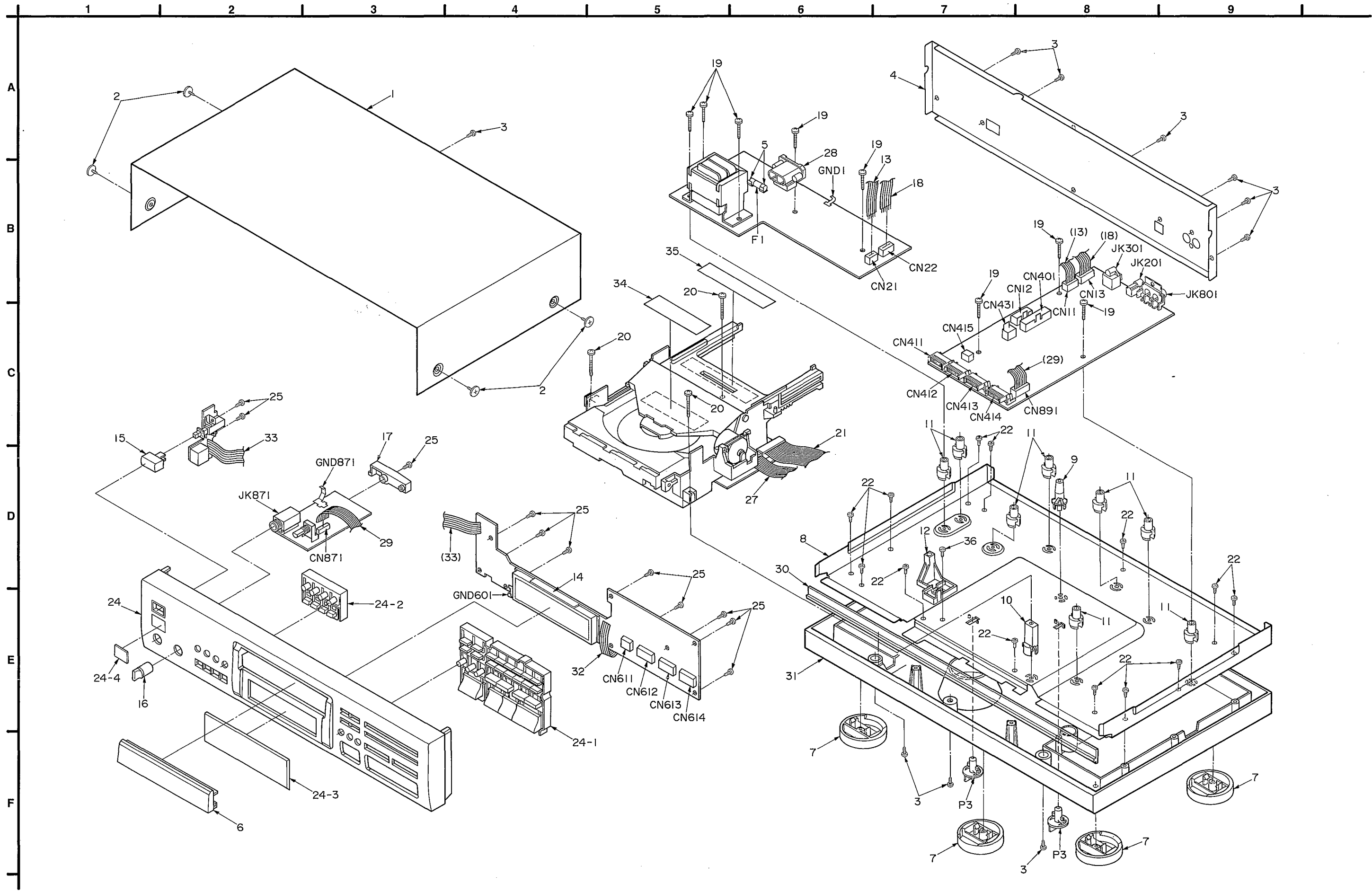

LOADING UNIT PARTS LOCATION

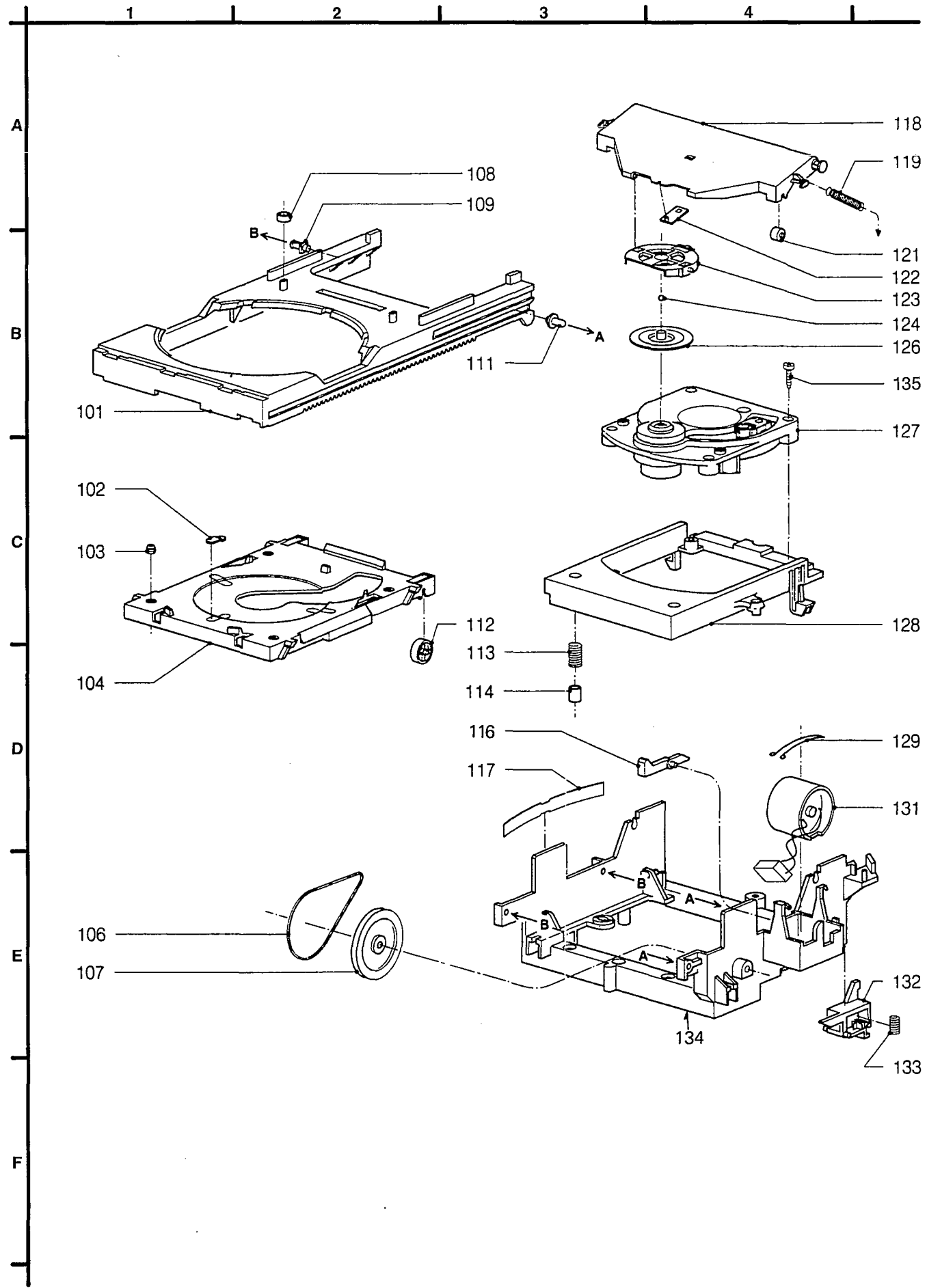

967