

Service Manual

Compact Disc Player

Compact Disc Player
SL-PS770A



Colour

(K) : Black

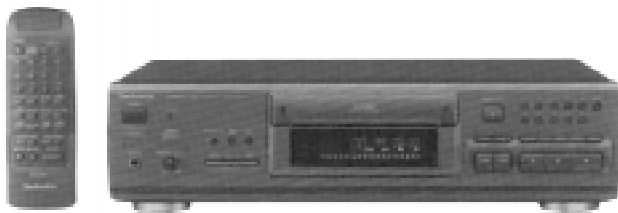

Areas

Suffix for Model No.	Area	Colour
(E)	Europe	(K)
(EB)	Britain	
(EG)	Germany and Italy	

RAE1100Z MECHANISM SERIES

SPECIFICATIONS \ ТЕХНИЧЕСКИЕ ХАРАКТЕРИСТИКИ
OPERATION CHECK AND MAIN COMPONENT REPLACEMENT PROCEDURES \ ПРОВЕРКА РАБОТЫ И ПРОЦЕДУРЫ ЗАМЕНЫ ОСНОВНЫХ КОМПОНЕНТОВ
BLOCK DIAGRAM \ БЛОК-СХЕМА
SCHEMATIC DIAGRAMS \ ПРИНЦИПИАЛЬНЫЕ СХЕМЫ
TERMINAL GUIDE OF IC'S, TRANSISTORS AND DIODES \ ЦОКОЛЕВКА ИНТЕГРАЛЬНЫХ СХЕМ, ТРАНЗИСТОРОВ И ДИОДОВ
WIRING CONNECTION DIAGRAM \ СХЕМА СОЕДИНЕНИЙ
AUTOMATIC ADJUSTMENT RESULTS DISPLAY FUNCTION \ ФУНКЦИЯ САМОДИАГНОСТИКИ И КОДЫ ОШИБОК
FUNCTION OF IC TERMINALS \ ФУНКЦИОНАЛЬНОЕ НАЗНАЧЕНИЕ ВЫВОДОВ ИНТЕГРАЛЬНЫХ МИКРОСХЕМ
REPLACEMENT PARTS LIST \ СПИСОК ЗАПАСНЫХ ЧАСТЕЙ
CABINET PARTS LOCATION \ РАСПОЛОЖЕНИЕ ЧАСТЕЙ КОРПУСА
LOADING UNIT PARTS LOCATION \ РАСПОЛОЖЕНИЕ ЧАСТЕЙ МЕХАНИЗМА ЗАГРУЗКИ
PACKAGING \ УПАКОВКА

© 1994 Matsushita Electric Industrial Co., Ltd.
 All rights reserved. Unauthorized copying and distribution is a violation of law.

Technics

Specifications

■ Audio

No. of channels	2 (left and right, stereo)
Frequency response	2 – 20,000 Hz, \pm 0.3 dB
Output voltage	2 V (at 0 dB)
Dynamic range	100 dB
S/N	115 dB
Harmonic distortion	0.0018% (1 kHz, 0 dB)
Total harmonic distortion	0.0023% (1 kHz, 0 dB)
Wow and flutter	Below measurable limit
DA converter	MASH (1 bit)
Output impedance	600 Ω
Load impedance	More than 10 k Ω
Headphone output level	15 mW max. 32 Ω (adjustable)

■ Pickup

Wavelength	780 nm
Laser Power	No hazardous radiation is emitted (with safety protection)

■ General

Power consumption	17 W
Power supply	AC 50/60 Hz, 230 – 240 V
Dimensions (W \times H \times D)	430 \times 114 \times 290 mm
Weight	4.0 kg

Note:

Specifications are subject to change without notice.
Weight and dimensions are approximate.

For United Kingdom only:

This apparatus was produced to BS 800.

*

● MASH is a trademark of NTT.

■ Operation Check and Main Component Replacement Procedures

Warning: This product uses a laser diode. Refer to caution statements on page 2.

ACHTUNG: Die Lasereinheit nicht zerlegen.

Die Lasereinheit darf nur gegen eine vom Hersteller spezifizierte Einheit ausgetauscht werden.

"ATTENTION SERVICER" Some chassis components may have sharp edges. Be careful when disassembling and servicing.

NOTE

1. This section describes procedures for checking the operation of the major printed circuit boards and replacing the main components.
2. For reassembly after operation checks or replacement, reverse the respective procedures. Special reassembly procedures are described only when required.
3. Select items from the following index when checks or replacement are required.
4. Illustrated screws are equivalent to actual size.
5. Refer the parts No. on the page of "Main Component Replacement Procedures", if necessary.

● Contents

	Page
● Checking Procedure for each P.C.B.	
1. Checking for the main P.C.B., operation P.C.B. and headphones jack P.C.B.	7
2. Checking for the servo P.C.B.	9
● Main Component Replacement Procedures	
1. Replacement for the traverse unit ass'y.....	10
2. Replacement for the loading belt and loading motor	13

■ Checking Procedure for each P.C.B.

1. Checking for the main P.C.B., operation P.C.B. and headphones jack P.C.B.

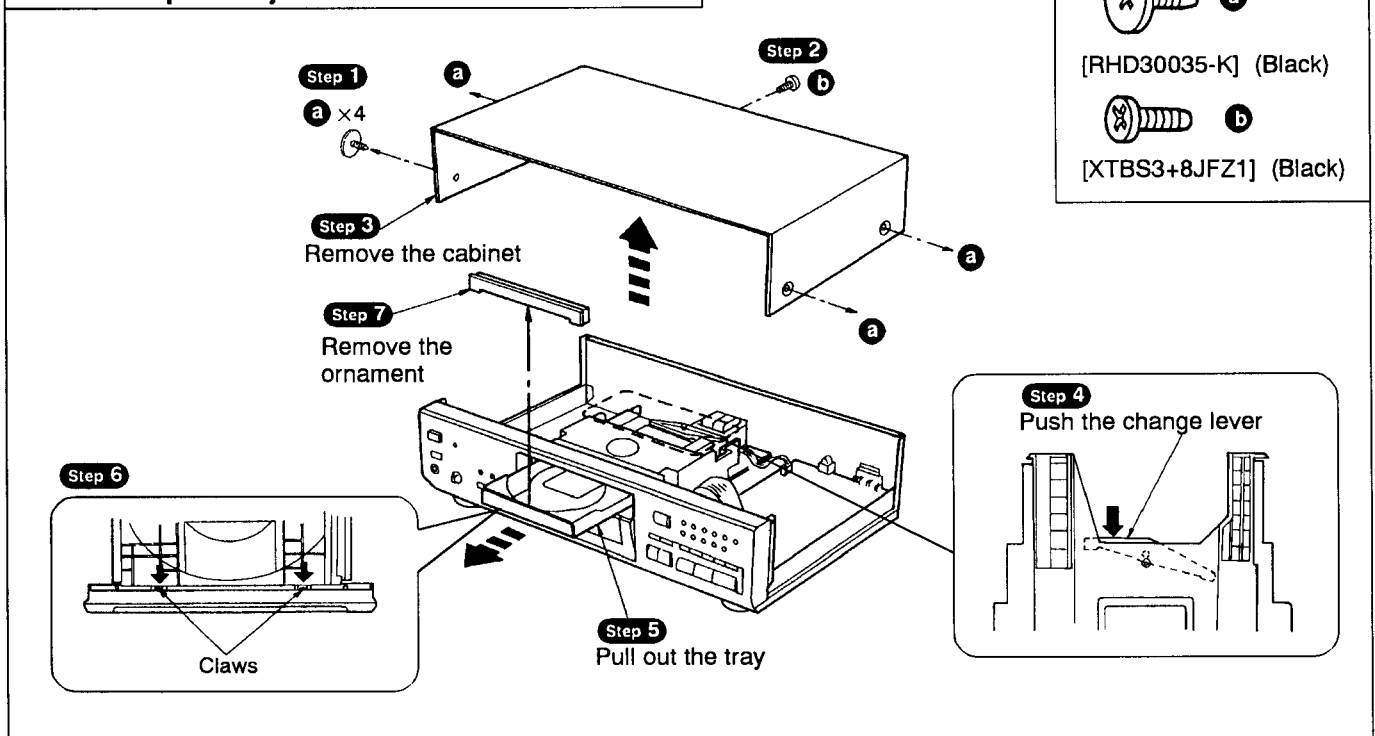

Step 9 Remove the front panel ass'y

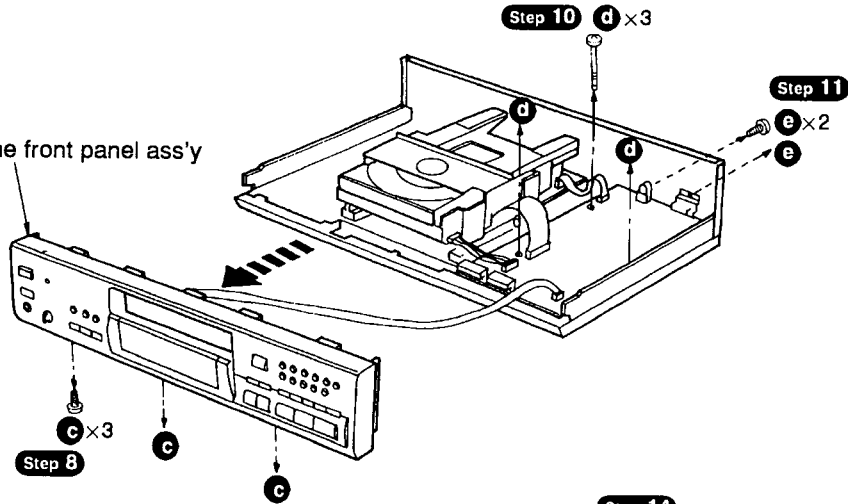

Step 14

Remove the main P.C.B. and then align it with the rib of bottom chassis.

Step 15

Reinstall the operation P.C.B. to the main P.C.B.

Step 13

Remove the operation P.C.B.

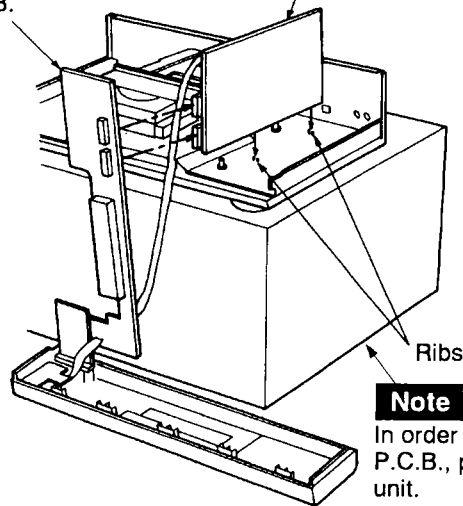
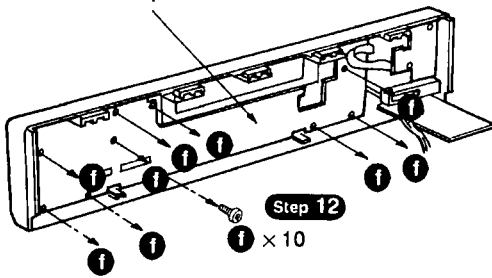

Note

In order to stand the operation P.C.B., place a box under the unit.

- Check the main P.C.B., operation P.C.B. and headphones jack P.C.B. as shown below.

Step 16

Connect the lead wire.

Step 17

Connect the lead wire.

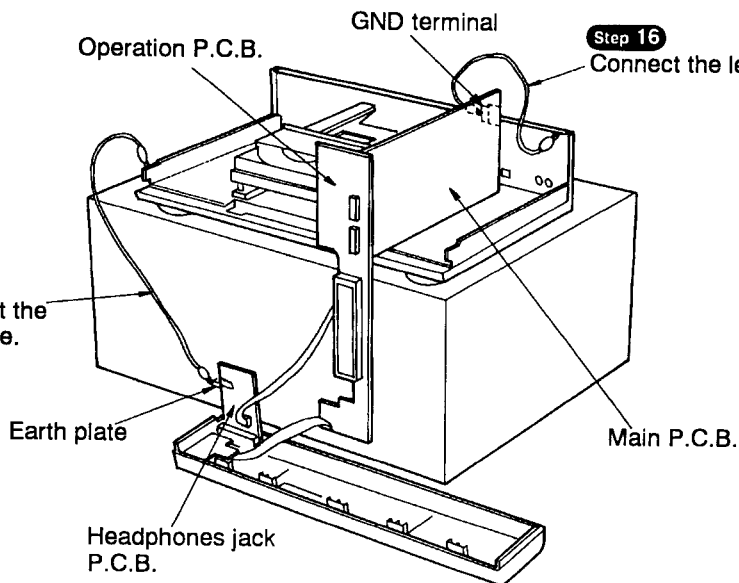

c

[XTB3+10JFZ] (Black)



d

[XTB3+20JFZ] (Black)



e

[XTBS3+8JFZ1] (Black)



f

[RHD26021]

2. Checking for the servo P.C.B.

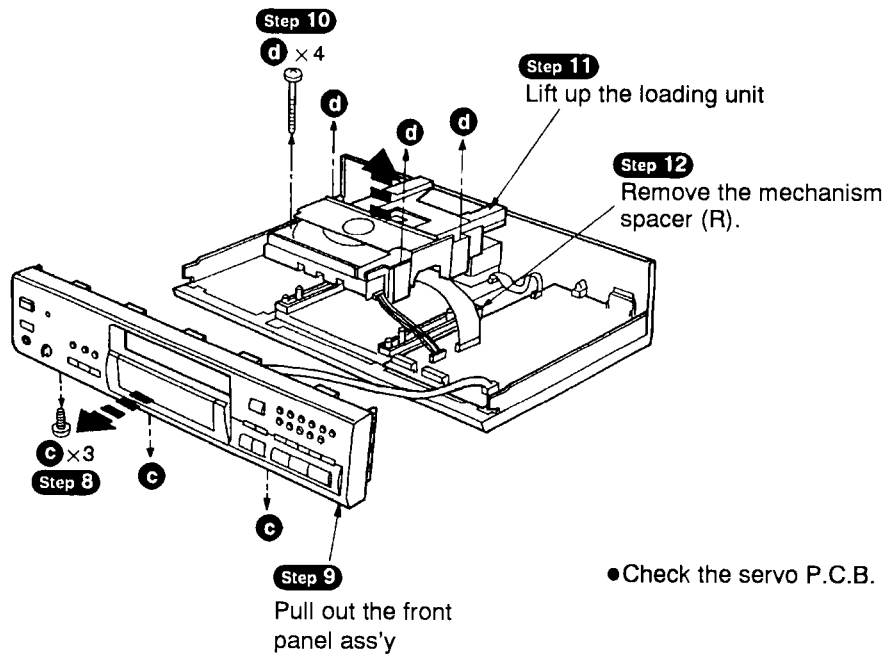
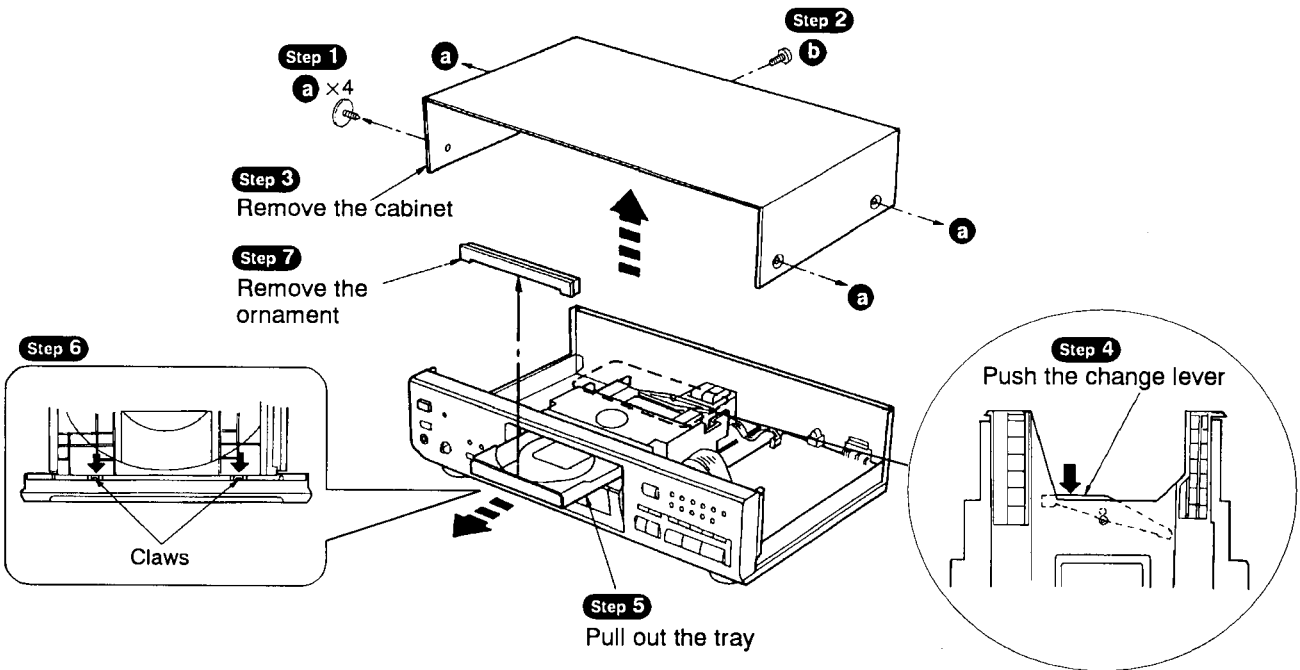

- a
[RHD30035-K] (Black)
- b
[XTBS3+8JFZ1] (Black)
- c
[XTB3+10JFZ] (Black)
- d
[RHD30052]

● Check the servo P.C.B. as shown below.

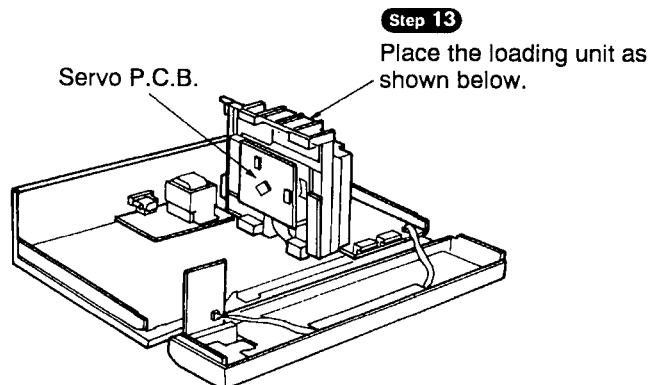

Main Component Replacement Procedures

1. Replacement for the traverse unit ass'y

- Follow the **Step 1** ~ **Step 11** of item 2 in checking procedure for each P.C.B. on page 9.

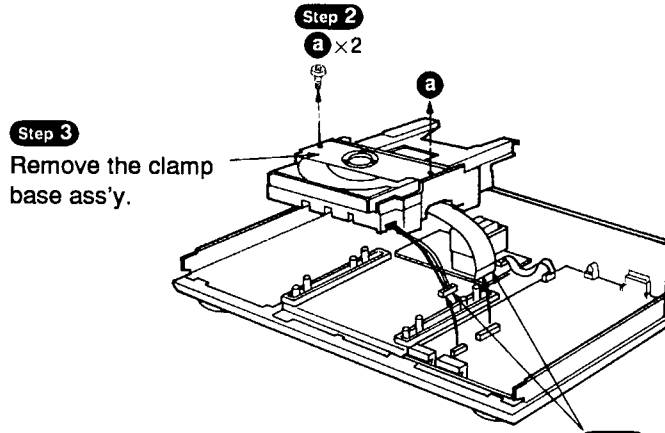
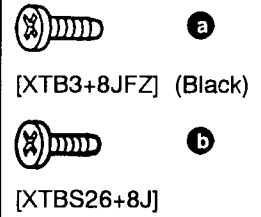

Remove the connector and FPC.

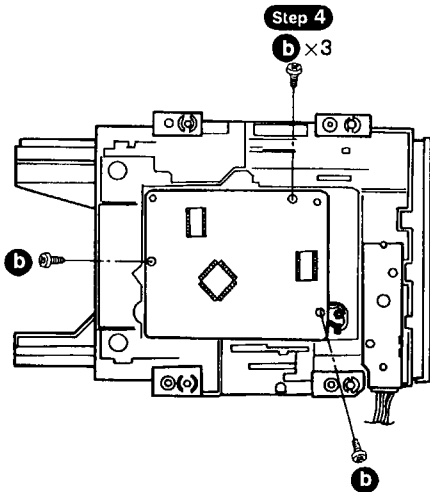

Removal of the flexible cable

- Push the top of the connector in the direction of arrow ①, and then pull out the flexible cable in the direction of arrow ②.

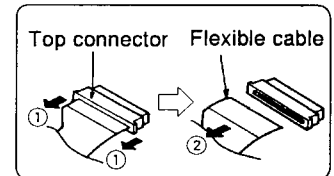

Step 5
Remove the connector (CN703).

Step 7
Remove the servo P.C.B.

Step 6
Remove the flexible cable from connector (CN701).

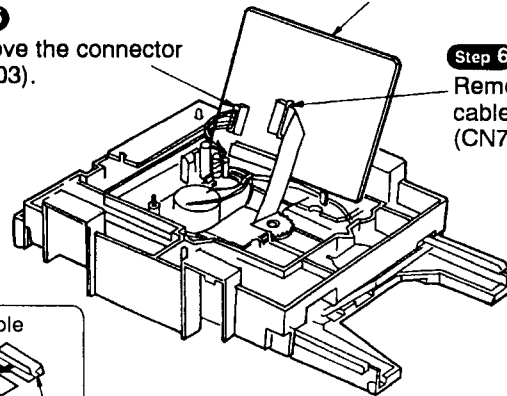

Note

Insert a shorting pin into the traverse unit flexible cable. (Refer to Handling Precautions for Traverse Deck on page 2.)

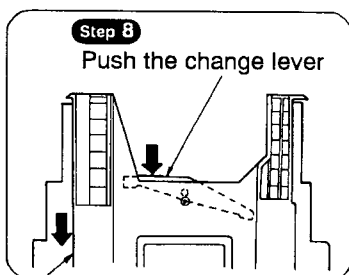
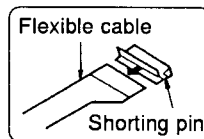

Step 9
Push the disc tray.

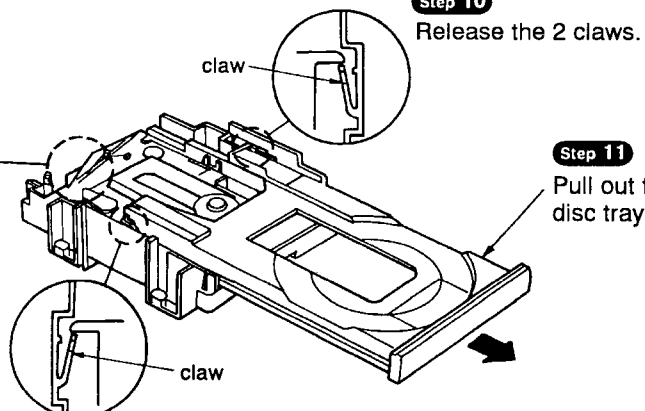

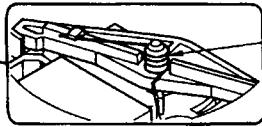
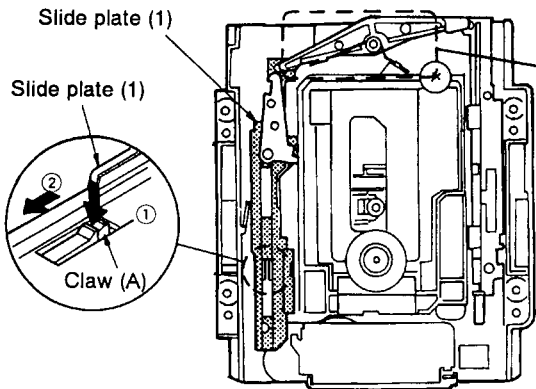

Step 12
Remove the spring.

Step 13
Push the claw (A) in the direction of arrow ①, and then move the slide plate (1) in the direction of arrow ②.

Note

Be careful not to damage the claw (A) because the claw (A) is breakable.

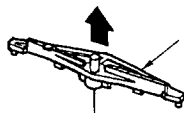
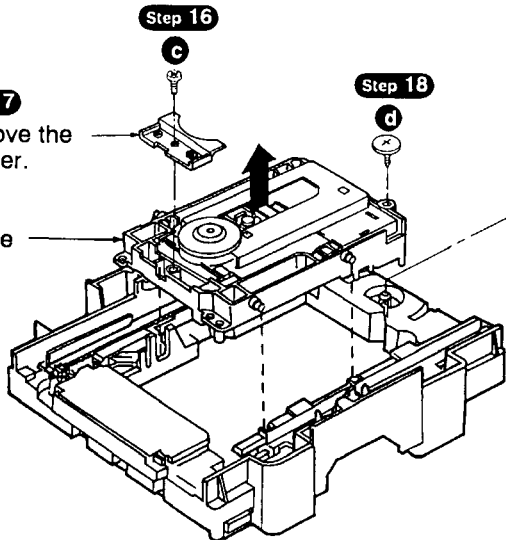

Step 14
Remove the change lever.

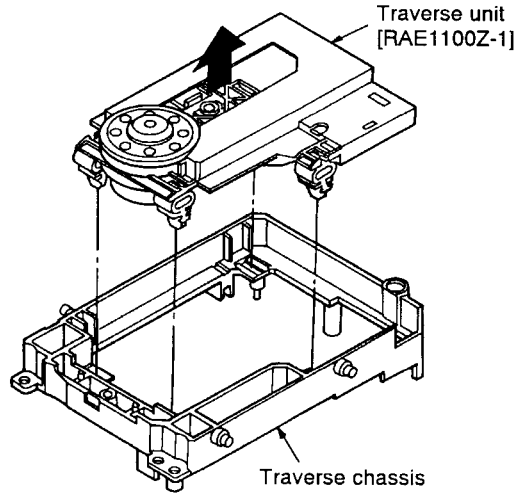
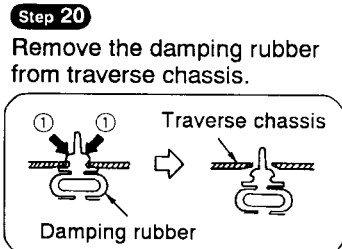
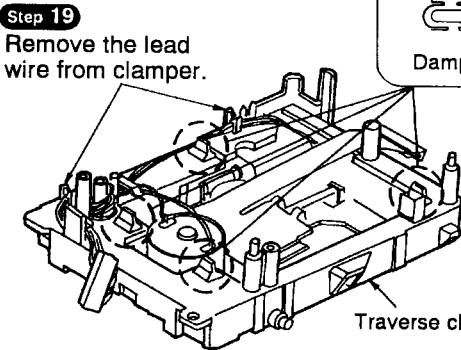
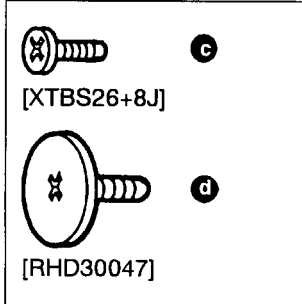

Installation of the disc tray after replacement

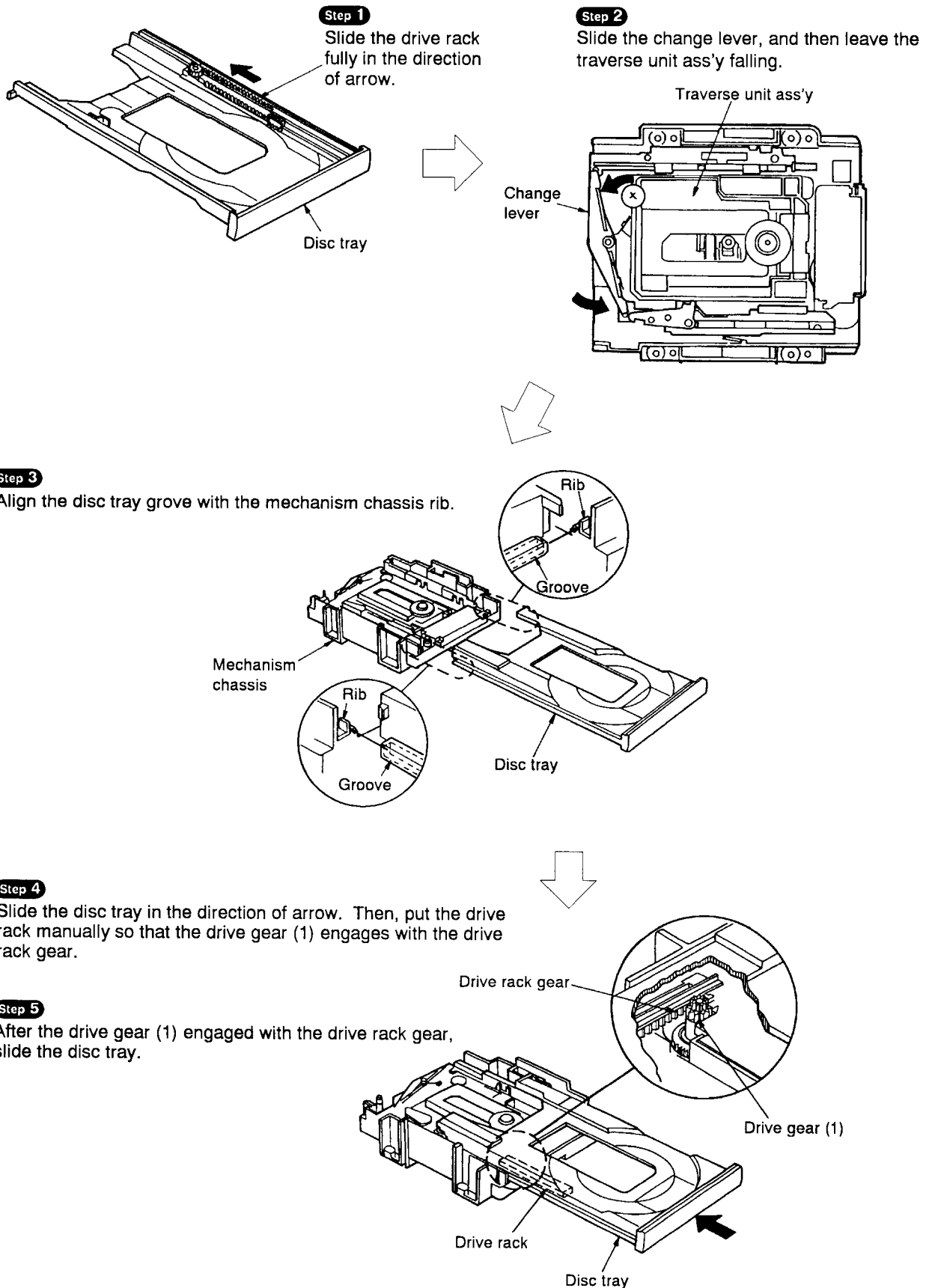

2. Replacement for the loading belt and loading motor

- Follow the **Step 1** ~ **Step 11** of item 2 in checking procedure for each P.C.B. on page 9.
- Follow the **Step 1** ~ **Step 7** of item 1 in main component replacement procedures on page 10.

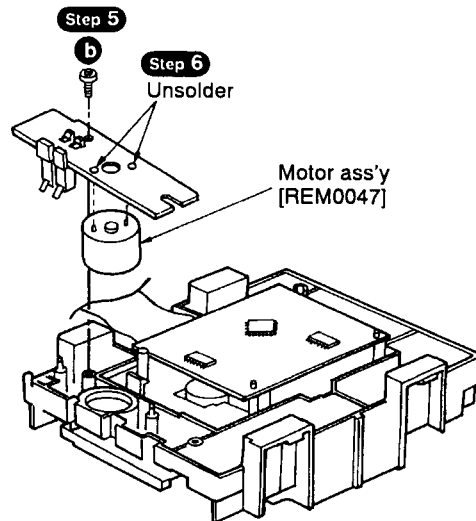
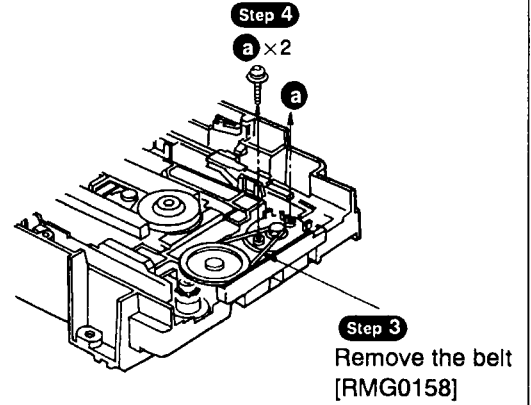
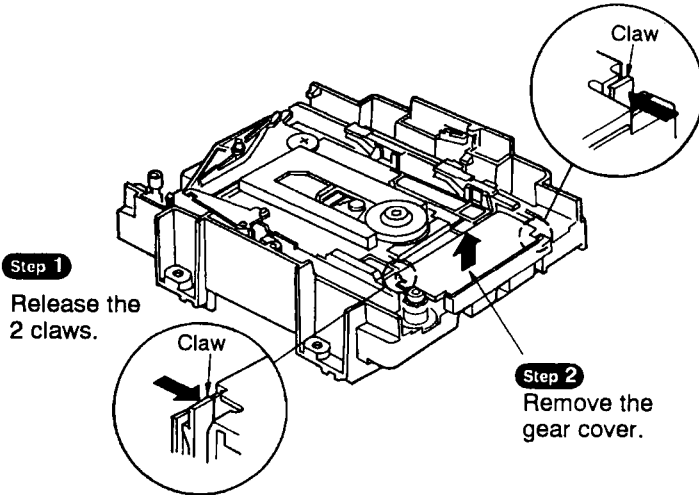
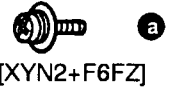

Polarity of motor ass'y terminals

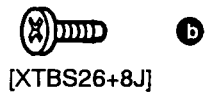
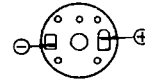

Block Diagram

Note: → AUDIO SIGNAL

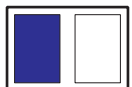
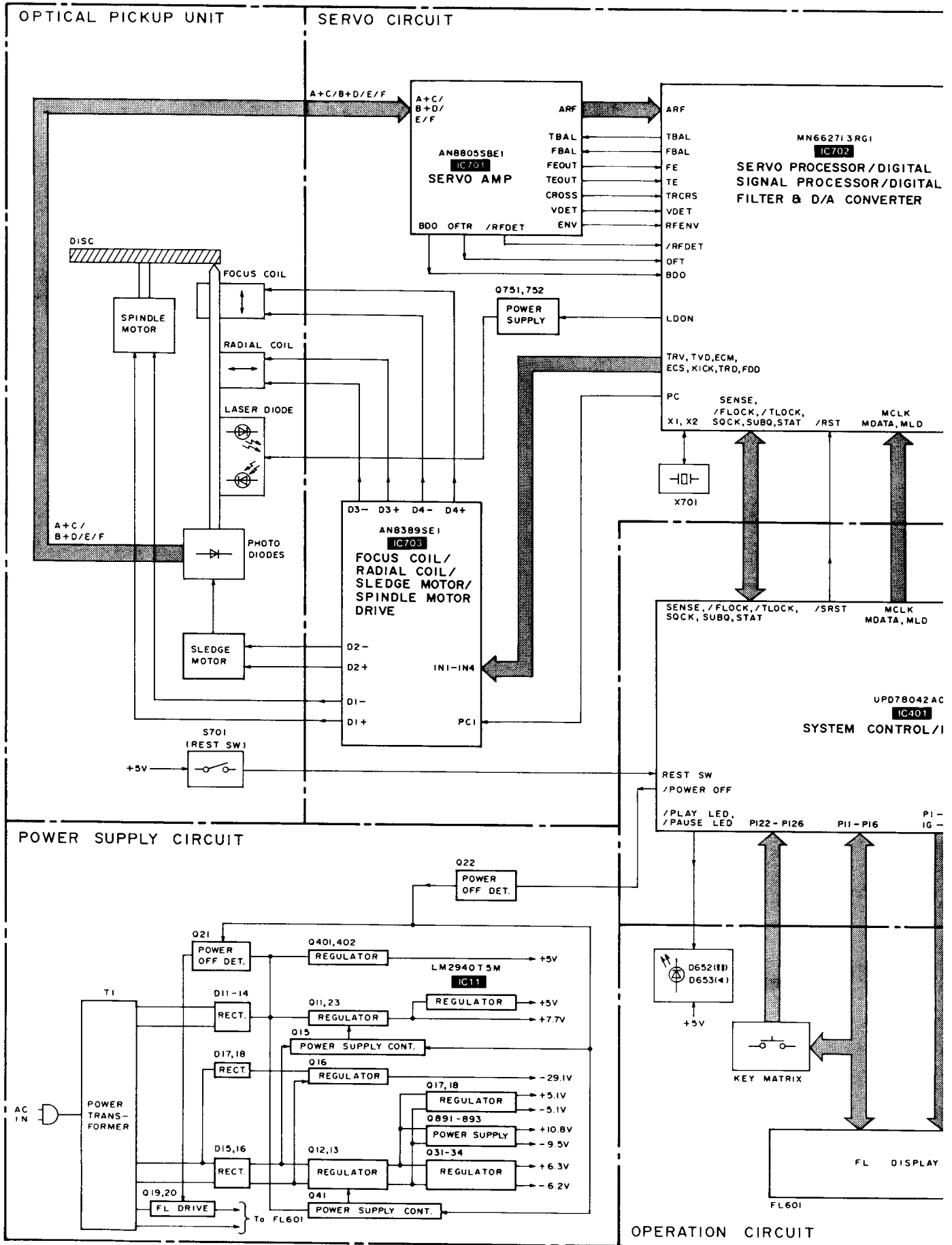

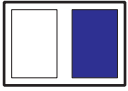
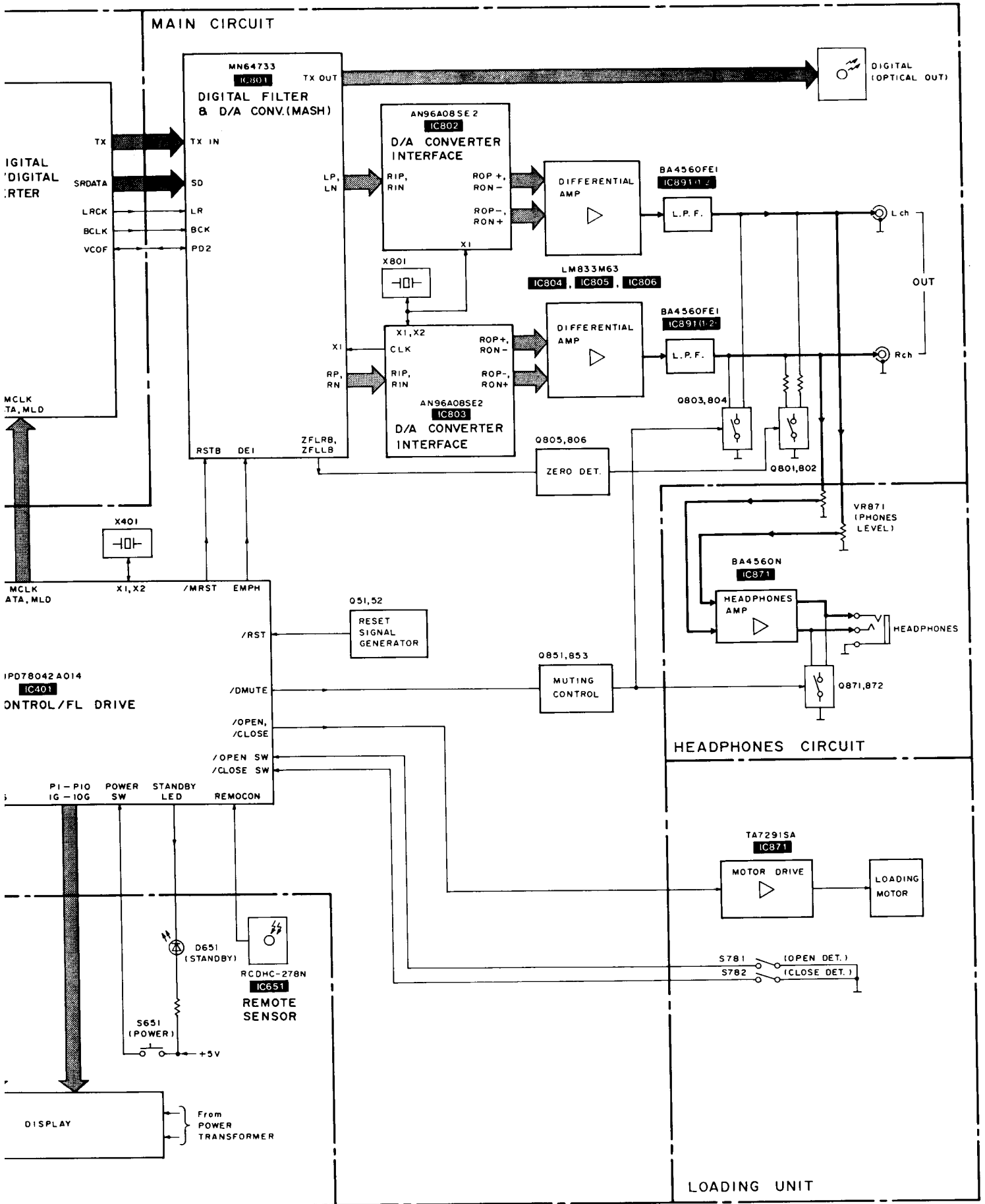

Schematic Diagram • Optical Pickup/Servo circuit (Parts list on Pages 34~37)

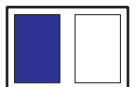
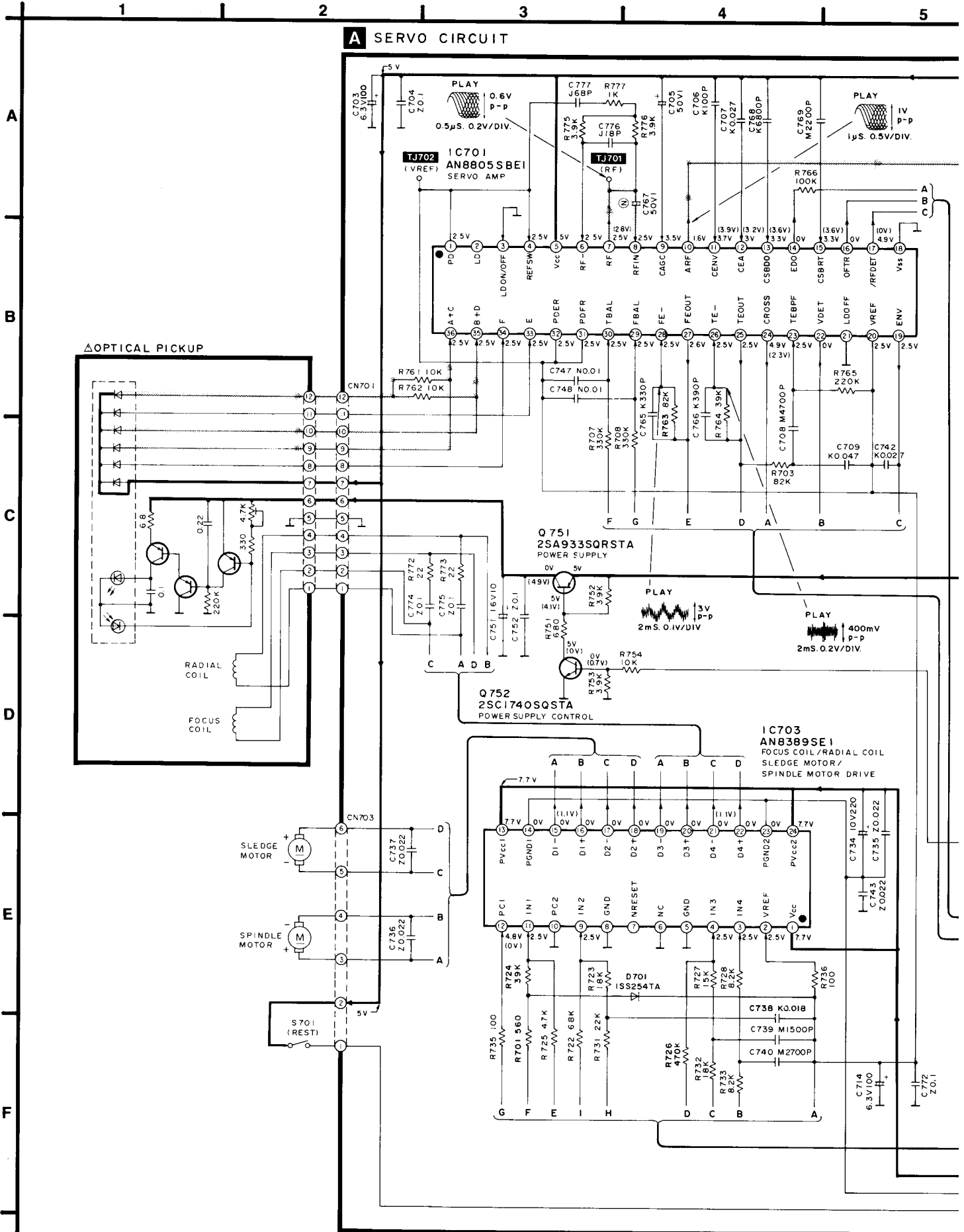

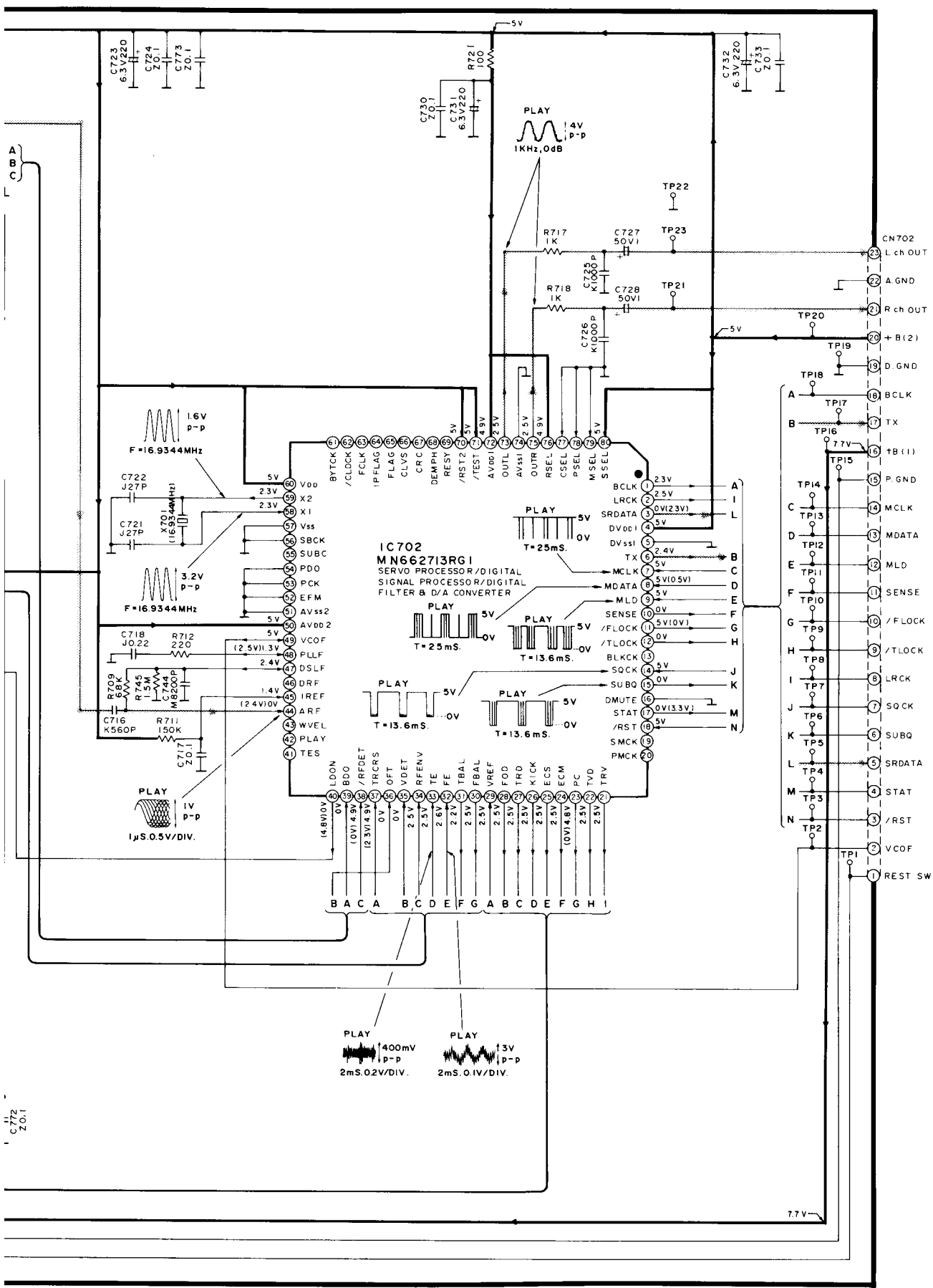

To E MAIN CIRCUIT (CN4011) (Page 20)

C772 Z0.1

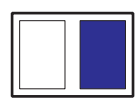

● Power Switch / Loading Motor / Operation / Power Supply / Headphones Jack / Main circuit

(Parts list on Pages 34~37)

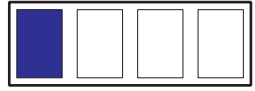
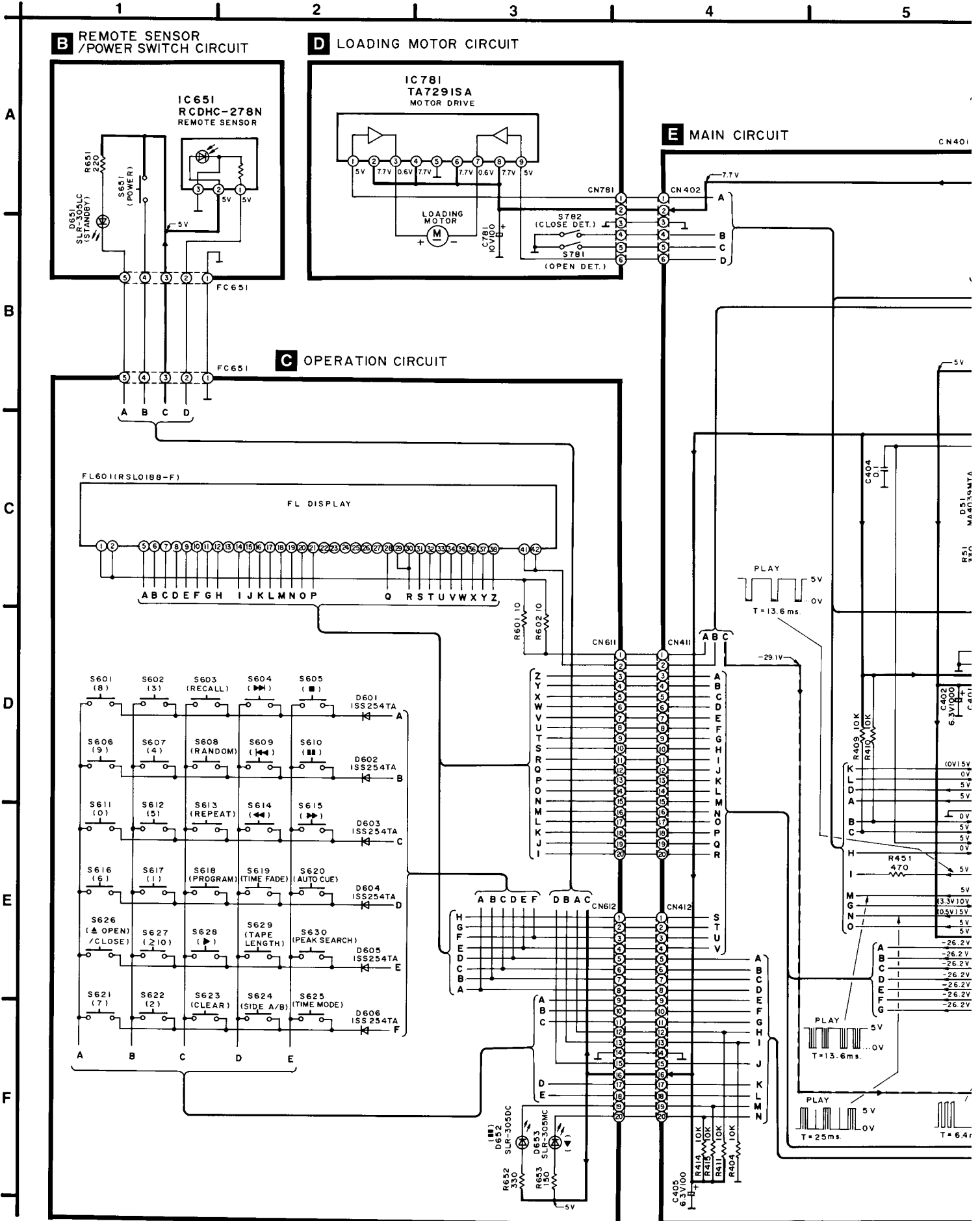

SL-PS770A

6

7

8

9

10

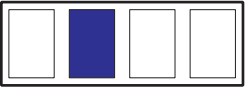
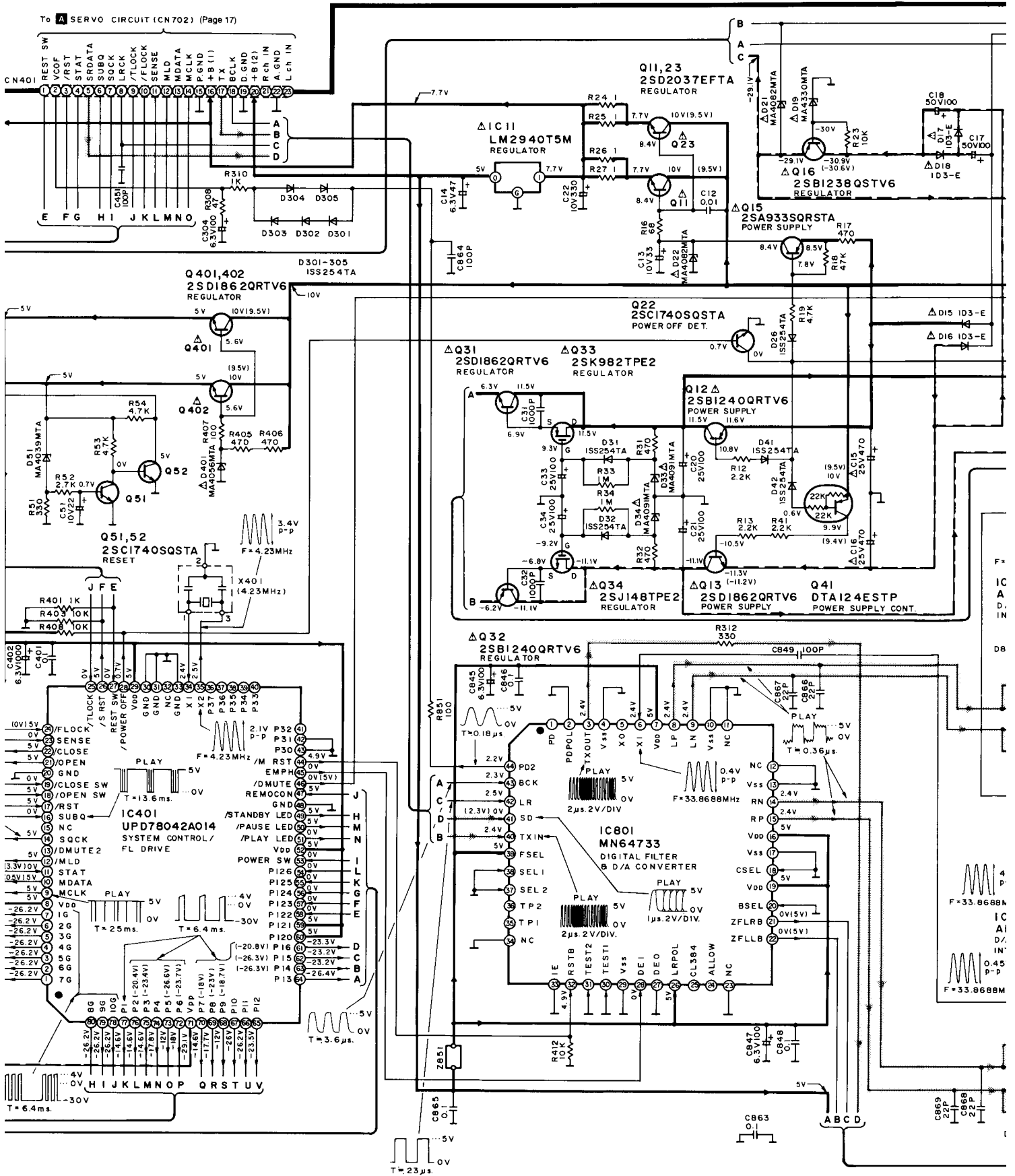

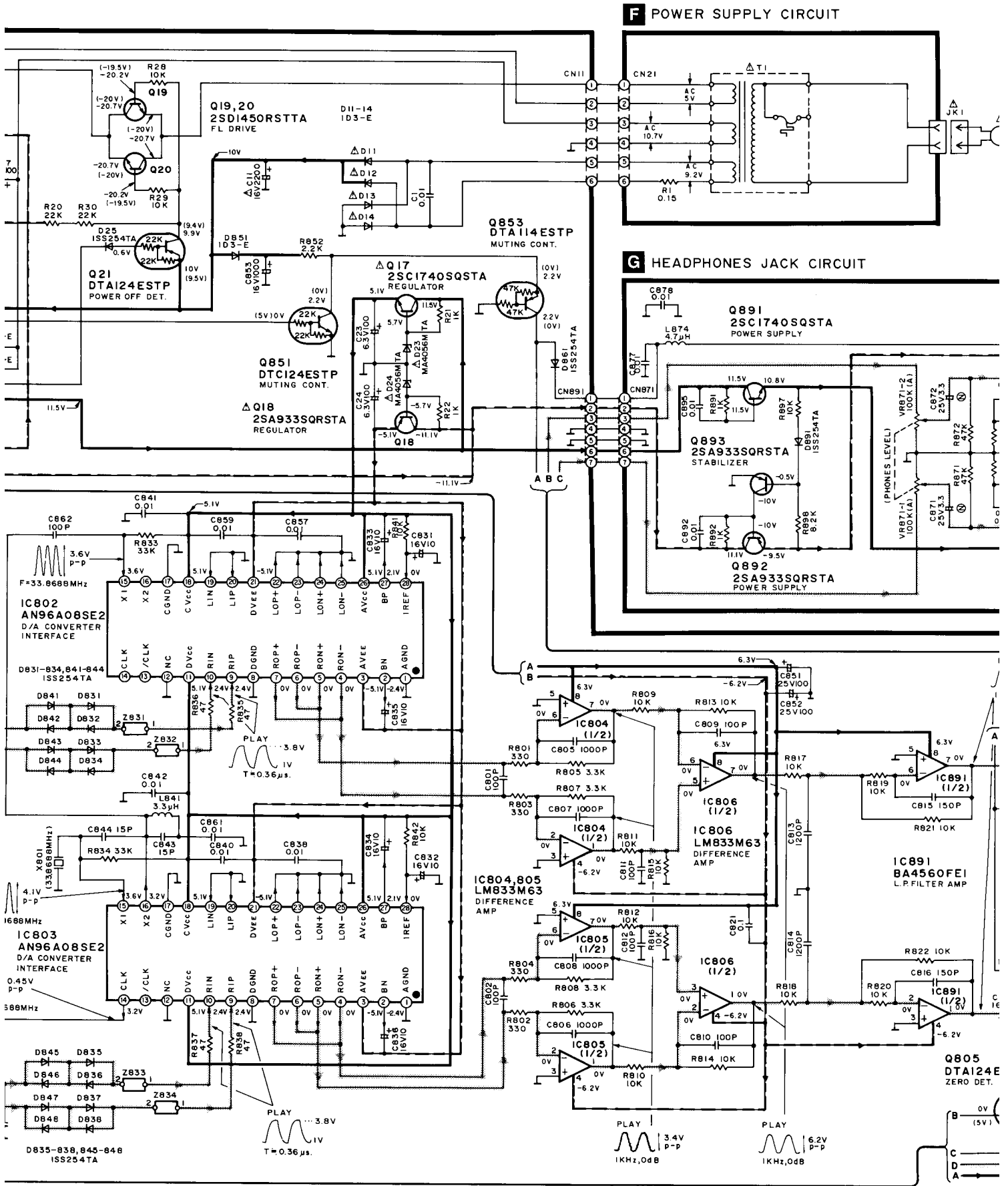

F POWER SUPPLY CIRCUIT

G HEADPHONES JACK CIRCUIT

Q805
DTA124E
ZERO DET.

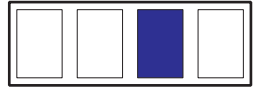

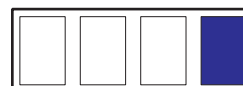
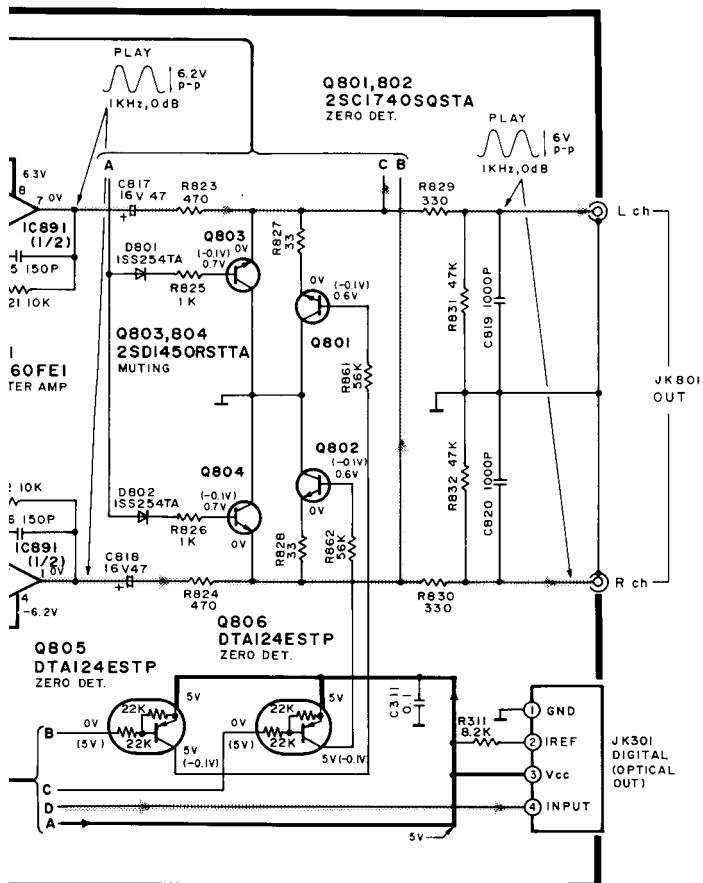
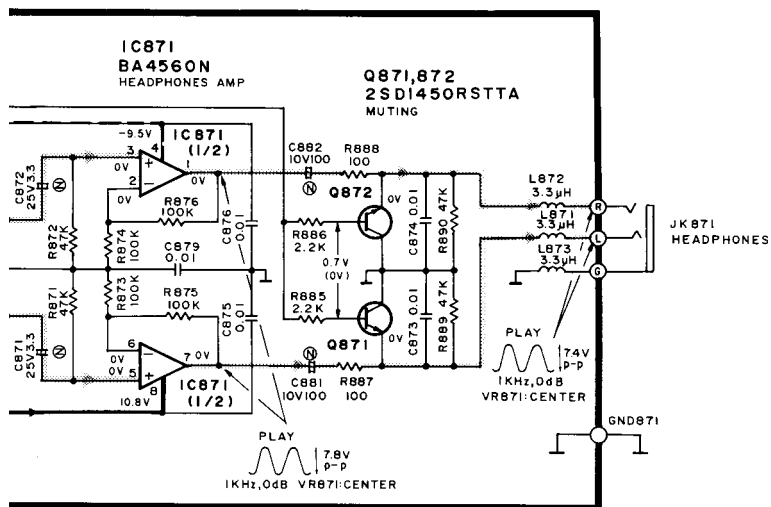
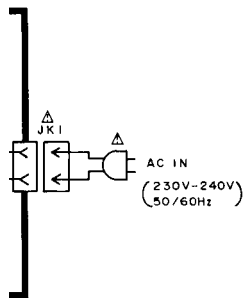

• Terminal guide of IC's, transistors and diodes

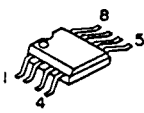
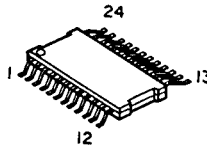
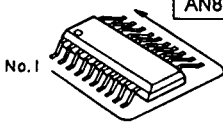
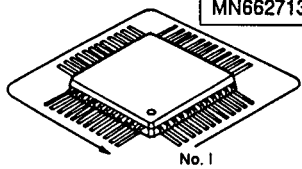
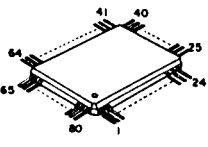
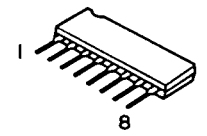
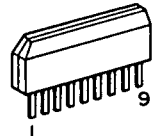
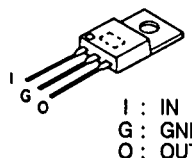
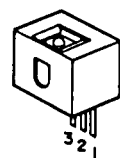
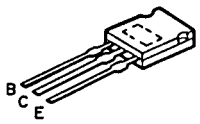
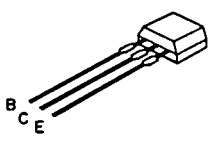
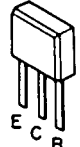
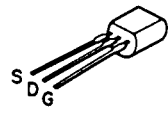
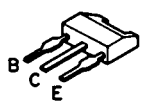
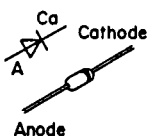
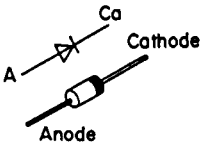
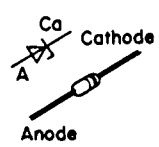
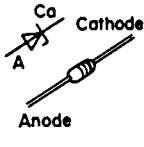
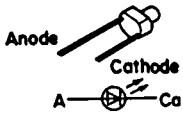
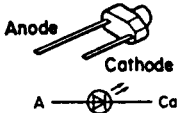
<p>BA4560FE1</p> 	<p>AN8389SE1</p> 	<table border="1" data-bbox="758 212 997 313"> <tr> <td>LM833M63</td> <td>8 Pin</td> </tr> <tr> <td>AN96A08SE2</td> <td>28 Pin</td> </tr> <tr> <td>AN8805SBE1</td> <td>36 Pin</td> </tr> </table> 	LM833M63	8 Pin	AN96A08SE2	28 Pin	AN8805SBE1	36 Pin	<table border="1" data-bbox="1236 212 1476 280"> <tr> <td>MN64733</td> <td>44 Pin</td> </tr> <tr> <td>MN662713RG1</td> <td>80 Pin</td> </tr> </table> 	MN64733	44 Pin	MN662713RG1	80 Pin
LM833M63	8 Pin												
AN96A08SE2	28 Pin												
AN8805SBE1	36 Pin												
MN64733	44 Pin												
MN662713RG1	80 Pin												
<p>UPD78042A014</p> 	<p>BA4560N</p> 	<p>TA7291SA</p> 	<p>LM2940T5</p>  <p>I : IN G : GND O : OUT</p>	<p>RCDHC-278N</p> 	<p>2SD2037EFTA</p> 								
	<p>2SD1450RTA</p> 	<p>2SK982TPE2 2SJ148TPE2</p> 	<p>2SB1238QSTV6 2SB1240-P 2SD1862QRTV6</p> 	<p>1SS254TA</p>  <p>Anode</p>									
<p>1D3-E</p>  <p>Anode</p>	<p>MA4330MTA</p>  <p>Anode</p>	 <p>Anode</p> <p>MA4039MTA MA4056MTA MA4082MTA MA4091-M</p>	<p>SLR-305LC</p>  <p>Anode</p> <p>A — ⊕ — Ca</p>	<p>SLR-305DC SLR-305MC</p>  <p>Anode</p> <p>A — ⊕ — Ca</p>									

Wiring Connection Diagram

NOTES:

- BLK Black
- BLU Blue
- BRN Brown
- GRY Gray
- GRN Green
- L.BLU... Light Blue
- ORG Orange
- PNK Pink
- RED Red
- SLD Shield Wire
- VLT Violet
- WHT White
- YEL Yellow

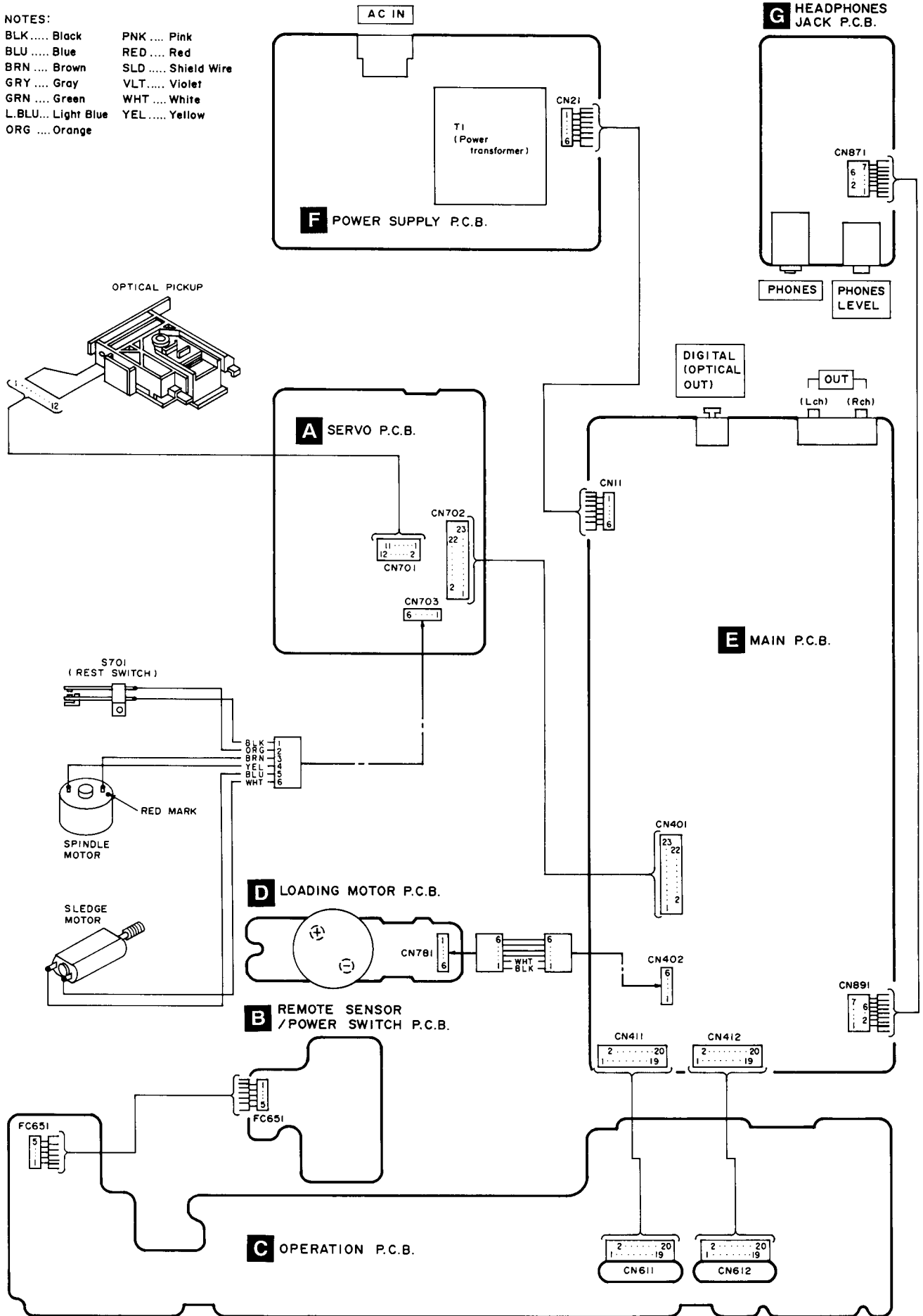

Automatic Adjustment Results Display Function

(Self-Check Function)

This unit has a function that uses the FL display board to indicate the results of automatic adjustment of the servo-circuit (tracking, focus, offset, etc.) as error codes. The error code display indicates the location of failures from automatic adjustment circuit.

The following procedure displays the error codes from the self-diagnostic function.

● Procedure for displaying automatic adjustment codes

1. Plug in the cord and wait for the STANDBY LED to flash, indicating the unit is in standby status.
2. Turn on the power supply switch while pressing the STOP (■), PAUSE (▢) and PLAY (▶) buttons at the same time.
3. The "F E C" code is displayed 2 or 3 seconds later to indicate the automatic adjustment results mode.
4. Push the OPEN/CLOSE button to open the disc tray and then load the test disc (SZZP1054C).
5. Push the OPEN/CLOSE button again to close the disc tray.
6. After automatic adjustment, the code display indicates the location of failures in the servo circuit.

● Troubleshooting using the automatic adjustment code

Notes:

1. If "E-00" is displayed as an error code, this means no error was found.
2. Check the disc and laser-detector lens for damage, contamination or stains.

- Take out the test disc and turn off the power, which terminates the automatic adjustment results mode.

FL error code display	Symptom	Probable cause	Signal to check		Normal voltage and waveform values	
			Location	Signal name	PLAY	STOP
E-01	Focus and tracking offset adjustments not completed in specified time period.	① Clocks X1 and X2, power supply VDD, and reset/RST, all on IC702. ② MDATA, MCLK, MLD, and SENSE signals to/from mechanism controller.	IC702 ⑧ pin	MDATA		4.8V
			IC702 ⑦ pin	MCLK		4.8V
			IC702 ⑨ pin	MLD		0V
			IC702 ⑩ pin	SENSE	0V	0V
			IC702 ⑱ pin	/RST	4.9V	4.9V
			IC702 ⑤⑧ pin	X1		
IC702 ⑤⑨ pin	X2					
E-03 E-05 E-07 E-09 E-0B E-0D E-0F	Disc play unstable	① Scratches or contaminants on disc surface ② Focus and Tracking servo circuits (check waveforms, voltages, and part values.) ③ Spindle driver circuit ④ Optical pickup	IC702 ③② pin	FE		2.4V
			IC702 ③③ pin	TE		2.4V
			IC702 ②⑧ pin	FOD	2.4V	2.4V
			IC702 ②⑦ pin	TRD	2.4V	2.4V
			IC702 ②⑥ pin	KICK	2.4V	2.4V
			IC702 ①① pin	/FLOCK	0V	4.9V
			IC702 ③⑧ pin	/RF DET	0V	4.8V
			TJ701	RF		3.4V
IC702 ①⑦ pin	STAT	4.9V	0V			
E-04 E-06 E-0C E-0E	Best "eye" (PD balance) adjustment not completed in specified time period.	① Scratches or contaminants on disc surface ② Focus servo circuits (check waveforms, voltages, and part values.) ③ Optical pickup	IC702 ③⑩ pin	FBAL	2.5V ± 1.25V	2.5V ± 1.25V
			TJ701	RF		3.4V
			IC702 ③② pin	FE		0V
			IC702 ③⑥ pin	OFT	0V	0V
			IC702 ①② pin	/TLOCK	0V	0V
E-08 E-0A	Focus or Tracking gain adjustment not completed in specified time period.	① Scratches or contaminants on disc surface ② Focus and Tracking servo circuit (check waveforms, voltages, and part values.) ③ Optical pickup	IC702 ③② pin	FE		2.4V
			IC702 ③③ pin	TE		2.4V
			IC702 ③⑥ pin	OFT	0V	0V
			IC702 ①② pin	/TLOCK	0V	0V

■ Function of IC Terminals

● IC401 (UPD78042A014)

Pin No.	Terminal Name	I/O	Function
1	7G	O	FL grid drive signal output
5	5		
7	1G		
8	VDD	—	Power supply (+ 5V)
9	MCLK	O	Microprocessor command clock
10	MDATA	O	Microprocessor command data
11	STAT	I	Status signal input
12	/MLD	O	Microprocessor command load signal
13	/DMUTE2	O	No used, open
14	SQCK	O	External clock for subcode Q register
15	NC	—	No used, open
16	SUBQ	I	Subcode Q input
17	/RST	I	Reset signal input
18	/OPEN SW	I	Disc tray "open" sense switch status
19	/CLOSE SW	I	Disc tray "close" sense switch status
20	GND	—	Connect to GND
21	/OPEN	O	Open Disc Tray command output
22	/CLOSE	O	Close Disc Tray command output
23	SENSE	I	Sense signal input
24	/FLOCK	I	Focus servo pull-in signal
25	/TLOCK	I	Tracking servo pull-in signal
26	/S RST	O	Reset signal output (for servo)
27	REST SW	I	Innermost track sense switch status
28	/POWER OFF	O	Power off command output
29	VDD	—	Power supply (+ 5V)
30	GND	—	Connect to GND
31	GND	—	Connect to GND
32	NC	—	No used, open
33	GND	—	Connect to GND
34	X1	I	Main clock (4.23 MHz) input
35	X2	O	Main clock output

● IC703 (AN8389SE1)

Pin No.	Terminal Name	I/O	Function
1	Vcc	—	Power supply
2	VREF	I	VREF input
3	IN4	I	Motor driver (4) input
4	IN3	I	Motor driver (3) input
5	GND	—	Ground connection
6	NC	—	Ground connection
7	NRESET	—	Reset input (no used, open)
8	GND	—	Ground connection
9	IN2	I	Motor driver (2) input
10	PC2	I	PC2 (power cut) input
11	IN1	I	Motor driver (1) input
12	PC1	I	PC1 (power cut) input

Pin No.	Terminal Name	I/O	Function
36	P37	I	No used, open
41	P32		
42	P31	I	Connect to GND
43	P30	I	
44	/MRST	O	Reset signal output for MASH (IC801)
45	EMPH	O	Emphasis signal output
46	/DMUTE	O	Muting signal output
47	REMOCON	I	Remote control signal input
48	GND	—	Connect to GND
49	/STANDBY LED	O	STANDBY LED control signal output
50	/PAUSE LED	O	PAUSE LED control signal output
51	/PLAY LED	O	PLAY LED control signal output
52	VDD	—	Power supply (+ 5V)
53	POWER SW	I	Power key switch signal input
54	P126	I	Key return signal input
58	P122		
59	P121	—	Connect to GND
60	P120		
61	P16	O	FL anode drive signal and key scan signal output
66	P11		
67	P10	O	FL anode drive signal output
70	P7		
71	VPP	—	Power supply terminal for FL drive (-32V)
72	P6	O	FL anode drive signal output
77	P1		
78	10G	O	FL grid drive signal output
80	8G		

Pin No.	Terminal Name	I/O	Function
13	PVcc1	—	Power supply (1) for driver
14	PGND1	—	Ground connection (1) for driver
15	D1-	O	Motor driver (1) reverse-action output
16	D1+	O	Motor driver (1) forward-action output
17	D2-	O	Motor driver (2) reverse-action output
18	D2+	O	Motor driver (2) forward-action output
19	D3-	O	Motor driver (3) reverse-action output
20	D3+	O	Motor driver (3) forward-action output
21	D4-	O	Motor driver (4) reverse-action output
22	D4+	O	Motor driver (4) forward-action output
23	PGND2	—	Ground connection (2) for driver
24	PVcc2	—	Power supply (2) for driver

● IC701 (AN8805SBE1)

Pin No.	Terminal Name	I/O	Function
1	PD	I	APC amplifier input
2	LD	O	APC amplifier output (No used, open)
3	LD ON/OFF	I	APC ON/OFF control signal
4	REFSW	I	Capacitor connection for CROSS
5	VCC	—	Power supply
6	RF-	I	RF amplifier inversion signal input
7	RF	O	RF amplifier signal output
8	RFIN	I	AGC signal input
9	CAGC	I	AGC loop filter connection
10	ARF	O	AGC signal output
11	CENV	I	Capacitor connection for RF detection
12	CEA	I	Capacitor connection for HPF amplifier
13	CSBDO	I	Capacitor connection for-RF envelope detection
14	EDO	O	BDO signal output
15	CSBRT	I	Capacitor connection for RF envelope detection
16	OFTR	O	OFTR signal output
17	/RFDET	O	RFDET signal output
18	Vss	—	GND
19	ENV	O	3TENV signal output
20	VREF	O	VREF signal output
21	LD OFF	—	APC OFF signal control
22	VDET	O	VDET signal output
23	TEBPF	I	VDET signal input
24	CROSS	O	CROSS signal output
25	TEOUT	O	TE amplifier signal output
26	TE-	I	TE amplifier inversion signal input
27	FEOUT	O	FE amplifier signal output
28	FE-	I	FE amplifier inversion signal input
29	FBAL	I	FBAL control signal
30	TBAL	I	TBAL control signal
31	PDFR	—	Adjustment for I-V amplifier conversion resistor
32	PDER	—	Adjustment for I-V amplifier conversion resistor
33	E	I	I-V amplifier signal input
34	F	I	I-V amplifier signal input
35	B+D	I	I-V amplifier signal input
36	A+C	I	I-V amplifier signal input

● IC702(MN662713RG1)

Pin No.	Terminal Name	I/O	Function
1	BCLK	O	Bit clock output for serial data
2	LRCK	—	LR identification signal output
3	SRDATA	—	Serial data output
4	DVdd1	—	Power supply input (for digital circuit)
5	DVss1	—	GND (for digital circuit)
6	TX	O	Digital audio interface signal output
7	MCLK	I	Microprocessor command clock signal input (Latches data at first transition)
8	MDATA	I	Microprocessor command data signal input
9	MLD	I	Microprocessor command load signal input
10	SENSE	O	Sense signal output (OFT, FESL, MAGEND, NAJEND, POSAD, SFG)
11	/FLOCK	O	Focus servo feeding signal output ("L": Feed)
12	/TLOCK	O	Tracking servo feeding signal output ("L": Feed)
13	BLKCK	O	Sub-code block clock signal output (fBLKCK = 75 Hz during normal playback) (no used, open)
14	SQCK	I	External clock signal input for sub-code Q resistor
15	SUBQ	O	Sub-code Q code output
16	DMUTE	I	Muting input ("H": Mute)
17	STAT	O	Status signal output (CRC, CUE, CLVS, TTSTVP, FCLV, SQCK)
18	/RST	I	Reset input
19	SMCK	—	1/2-divided clock signal of crystal oscillating at MSEL = "H" (fSMCK = 8.4672 MHz) 1/4-divided clock signal of crystal oscillating at MSEL = "L" (fSMCK = 4.2336 MHz) (no used, open)
20	PMCK	—	1/192-divided clock signal of crystal oscillating (fPMCK = 88.2 kHz) (no used, open)
21	TRV	O	Traverse forced feed output
22	TVD	O	Traverse drive output
23	PC	O	Spindle motor ON signal output ("L": ON)
24	ECM	O	Spindle motor drive signal output (forced mode output)
25	ECS	O	Spindle motor drive signal output (servo error signal output)
26	KICK	O	Kick pulse output
27	TRD	O	Tracking drive output
28	FOD	O	Focus drive output
29	VREF	I	D/A (drive) output (TVD, ECS, TRD, FOD, FBAL, TBAL) reference voltage input
30	FBAL	O	Focus balance adjustment output
31	TBAL	O	Tracking balance adjustment output

● IC702 Continued

Pin No.	Terminal Name	I/O	Function
32	FE	I	Focus error signal input (analog input)
33	TE	I	Tracking error signal input (analog input)
34	RFENV	I	RF envelope signal input
35	VDET	I	Vibration detection signal input ("H": detection)
36	OFT	I	Off-track signal input ("H": off track)
37	TRCRS	I	Track cross signal input
38	/RFDET	I	RF detection signal input ("L": detection)
39	BDO	I	Dropout signal input ("H": Dropout)
40	LDON	O	Laser on signal output ("H": ON)
41	TES	O	Tracking error shunt signal output ("H": shunt) (no used, open)
42	PLAY	O	Play signal out ("H": PLAY) (no used, open)
43	WVEL	O	Double speed status signal output ("H": Double speed) (no used, open)
44	ARF	I	RF signal input
45	IREF	I	Reference current input
46	DRF	—	DSL bias (no used, open)
47	DSLFB	I/O	DSL loop filter
48	PLLF	I/O	PLL loop filter
49	VCOF	I/O	VCO loop filter
50	AVdd2	—	Power supply input (for analog circuit)
51	AVss2	—	GND (for analog circuit)
52	EFM	—	EFM signal output (not used, open)
53	PCK	—	PLL extraction clock output (fPCK= 4.321MHz during normal playback) (no used, open)
54	PDO	—	Phase comparison signal of EFM and PCK signals (no used, open)
55	SUBC	O	Sub-code serial data output (no used, open)
56	SBCK	I	Clock input for sub-code serial data
57	Vss	—	GND
58	X1	I	Crystal oscillating circuit input (f = 16.9344MHz)
59	X2	O	Crystal oscillating circuit output (f = 16.9344MHz)
60	Vdd	—	Power supply input (for oscillating circuit)
61	BYTCK	—	Byte clock output (no used, open)
62	/CLDCK	O	Sub-code frame clock signal output (fCLDCK = 7.35kHz during normal playback)
63	FCLK	—	Crystal frame clock signal output (fFCLK = 7.35kHz, double = 14.7kHz)
64	IPFLAG	O	Interpolation flag output ("H": Interpolation) (no used, open)
65	FLAG	O	Flag output (no used, open)

Pin No.	Terminal Name	I/O	Function
66	CLVS	O	Spindle servo phase synchronizing signal output ("H": CLV, "L": rough servo) (no used, open)
67	CRC	O	Sub-code CRC checked output ("H": OK, "L": NG) (no used, open)
68	DEMPH	O	De-emphasis ON signal output ("H": ON) (no used, open)
69	RESY	—	Frame resynchronizing signal output (no used, open)
70	/RST2	I	Reset input through MASH circuit ("L": Reset)
71	/TEST	I	Test input
72	AVdd1	—	Power supply input (for analog circuit)
73	OUTL	O	Left channel audio signal output
74	AVss1	—	GND
75	OUTR	O	Right channel audio signal output
76	RSEL	I	RF signal polarity assignment input (at "H" level: RSEL = "H") (at "L" level: RSEL = "L")
77	CSEL	I	Crystal oscillating frequency designation input ("L": 16.9344MHz, "H": 33.8688MHz)
78	PSEL	I	Test input (normally, "L")
79	MSEL	I	Output frequency switching for SMCK terminal "H": SMCK = 8.4672MHz "L": SMCK = 4.2336MHz
80	SSEL	I	Output mode switching of SUBQ terminal ("H": Q code buffer mode)

● IC801 (MN64733)

Pin No.	Terminal Name	I/O	Function
1	PD	—	No used, open
2	PDPOL	—	No used (Connect to GND)
3	TXOUT	O	128 fs synchronization signal output for TXIN
4	VSS	—	Connect to GND
5	XO	O	No used, open
6	XI	I	Input for external clock signal
7	VDD	I	Power supply (+ 5V)
8	LP	O	L-ch positive-phase (PWM) detection signal output
9	LN	O	L-ch negative-phase (PWM) detection signal output
10	VSS	—	Connect to GND
11	NC	—	No used (Connect to GND)
12	NC	—	No used (Connect to GND)
13	VSS	—	Connect to GND
14	RN	O	R-ch negative-phase (PWM) detection signal output
15	RP	O	R-ch positive-phase (PWM) detection signal output
16	VDD	I	Power supply (+ 5V)
17	VSS	—	Connect to GND
18	CSEL	I	No used (Connect to GND)
19	VDD	I	Power supply (+ 5V)
20	BSEL	I	No used (Connect to GND)
21	ZFLRB	O	Output the internal detector signal for R-ch $-\infty$

Pin No.	Terminal Name	I/O	Function
22	ZFLLB	O	Output the internal detector signal for L-ch $-\infty$
23	NC	—	Connect to GND
24	ALLOW	O	No used, open
25	CL384	O	
26	LRPOL	I	Connect to VDD
27	DEO	I	Connect to GND
28	DEI	I	De-emphasis mode select signal input
29	VSS	—	Connect to GND
30	TEST1	I	No used (Connect to GND)
31	TEST2		
32	RSTB	I	Reset signal input
33	IE	—	No used (Connect to GND)
34	NC		
35	TP1	O	No used, open
36	TP2		
37	SEL2	I	No used (Connect to GND)
38	SEL1		
39	FSEL	I	Input the MASH clock mode select signal ("H": 64 fs)
40	TXIN	I	Digital audio interface signal input
41	SD	I	Serial data input
42	LR	I	L-ch/R-ch clock signal input
43	BCK	I	Serial data and bit clock signal input
44	PD2	O	Output the bit clock signal, 64 fs phase comparison signal

Cabinet Parts Location

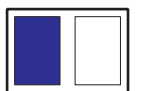
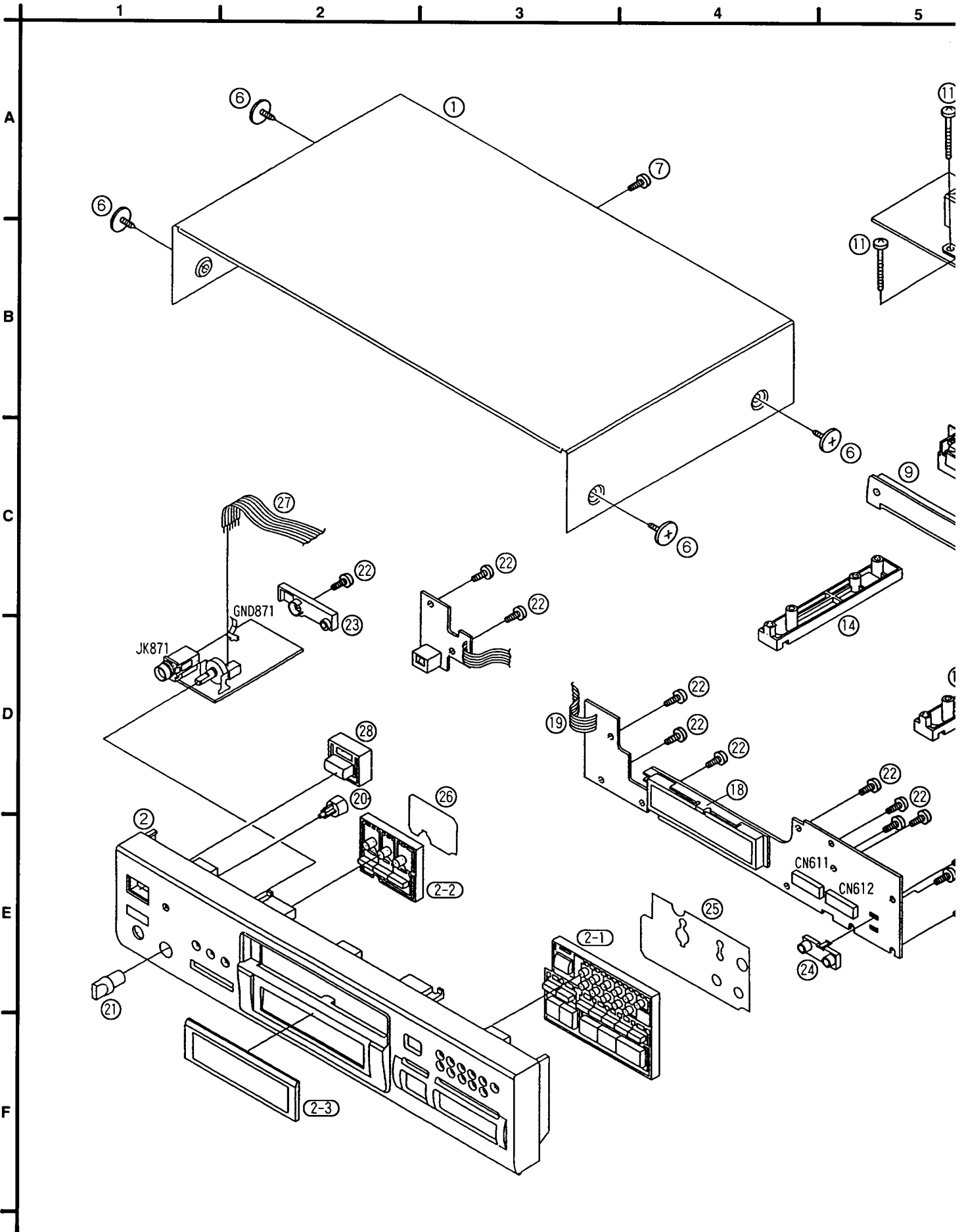

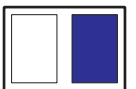
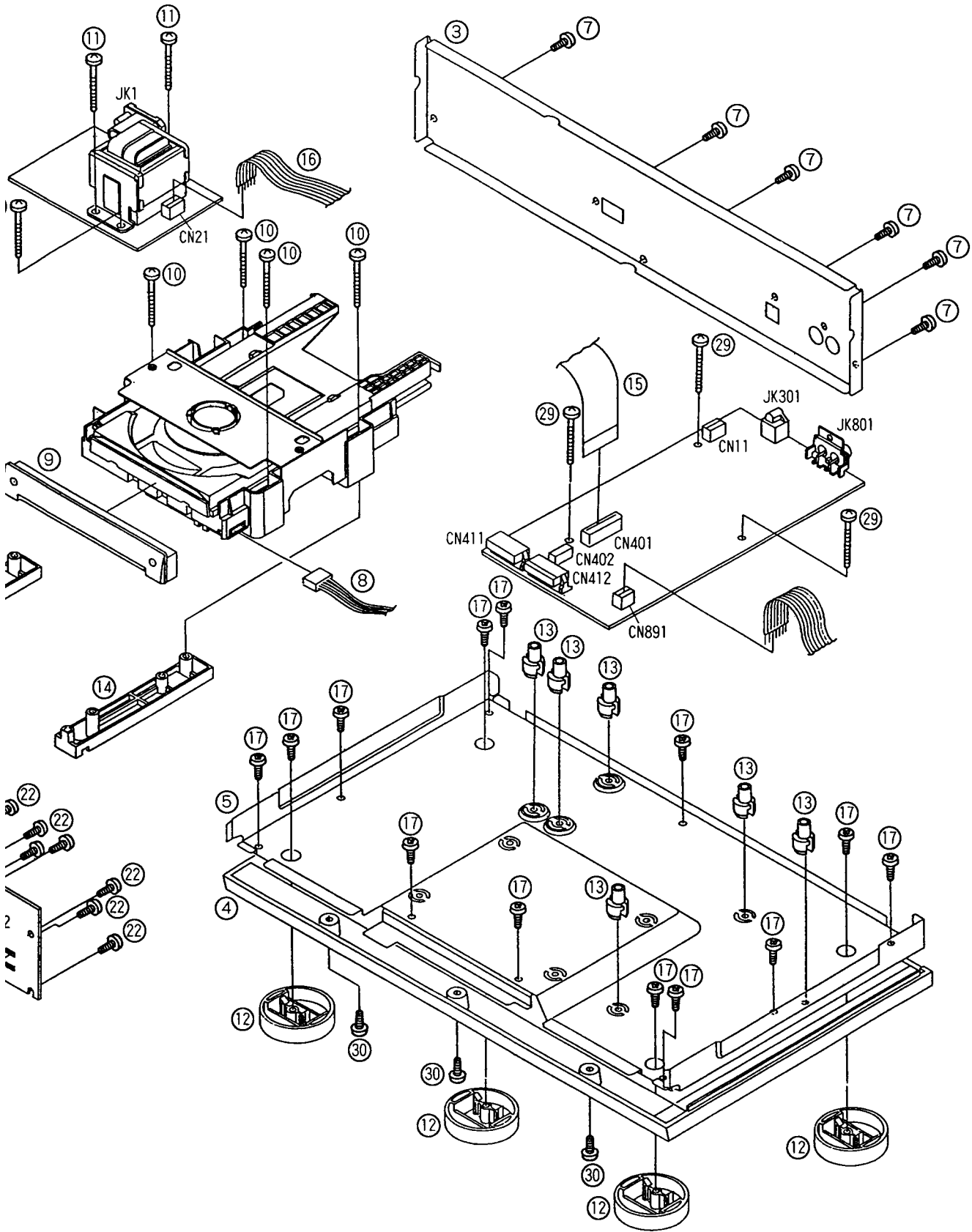

Loading Unit Parts Location

Note:

When changing mechanism parts, apply the specified grease to areas marked "xx" as shown in the drawing.

Ref No.	Part No.
①	RFKXEM30L

A
B
C
D
E
F

