

Service Manual

COMPACT
disc
DIGITAL AUDIO

DIGITAL

MASH[®]
multi-stage noise shaping

Compact Disc Player

SL-PS840

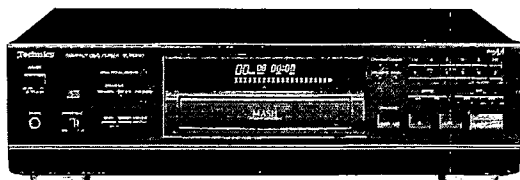

Colour

(K)... Black Type

Area

Suffix for Model No.	Area	Colour
(E)	Europe.	(K)
(EB)	Great Britain.	
(EG)	Germany & Italy.	
(GC)	Asia, Latin America, Middle Near east and Africa.	
(GN)	Oceania.	

- ※
- Technics (or Panasonic) developed the world's first MASH type DAC and ADC. MASH technology was invented by NTT (LSI Labs).
 - MASH is a trademark of NTT.

SL-P2000 MECHANISM SERIES (RAE0201-1)

SPECIFICATIONS

■ Audio

No. of channels	2 (left and right, stereo)
Frequency response	2–20,000 Hz, ± 0.3 dB
Output voltage	2.3 V (at 0 dB)
Dynamic range	99 dB
S/N	118 dB
Harmonic distortion	0.0015% (1 kHz, 0 dB)
Total harmonic distortion	0.0018% (1 kHz, 0 dB)
Channel separation	110 dB
Wow and flutter	Below measurable limit
DA converter	Advanced MASH (1 bit)
Output impedance	Approx. 1 k Ω
Load impedance	More than 10 k Ω
Headphone output level	15 mW max. 32 Ω (adjustable)

■ Pickup

Wavelength	780 nm
Laser Power	No hazardous radiation is emitted (with safety protection)

■ General

Power consumption	17 W
Power supply	
For (E, EB, EG, GN) areas.:	AC 50/60 Hz, 230–240 V
For (GC) area.:	AC 50/60 Hz, 110 V/127 V/220 V/240 V
Dimensions (W × H × D)	430 × 125 × 335 mm
Weight	6.3 kg

Note:

Design and specifications are subject to change without notice. Weight and dimensions are approximate.

Technics

CONTENTS

	Page		Page
ACCESSORIES	2	TROUBLESHOOTING GUIDE.....	19, 20
BEFORE TRANSPORTING THE UNIT	2	MEASUREMENTS AND ADJUSTMENTS	21, 22
PRECAUTION OF LASER DIODE.....	3	TERMINAL FUNCTION OF IC'S.....	23~27
FRONT PANEL CONTROLS AND FUNCTIONS	4, 5	INTERNAL CONNECTION OF FL	28
CAUTION FOR AC MAINS LEAD	5	BLOCK DIAGRAM.....	29~31
CONNECTIONS	6	SCHEMATIC DIAGRAM	32~38
CONCERNING THE REMOTE CONTROL	7	PRINTED CIRCUIT BOARDS	39~42
HANDLING PRECAUTIONS FOR OPTICAL PICKUP	8	WIRING CONNECTION DIAGRAM.....	43
DISASSEMBLY INSTRUCTIONS.....	9~14	REPLACEMENT PARTS LIST.....	44, 48~50
DISPLAY FUNCTION OF AUTOMATICALLY-ADJUSTED RESULTS (SELF-CHECK FUNCTION).....	15, 16	EXPLODED VIEWS	45~47
DIGITAL SERVO SYSTEM.....	17, 18	RESISTORS AND CAPACITORS	51, 52
		PACKAGING	52

ACCESSORIES

Note:

The configuration of the AC power supply cord differs according to area.

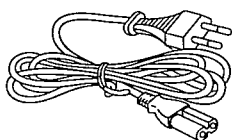

AC power supply cord 1 pc.
[RJA0019-2K (E, EG, GC)
VJA0733 (EB), SJA173 (GN)]

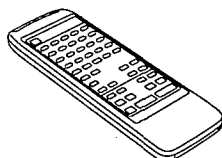

Remote control transmitter..... 1 pc.
(RAK-SL512W)

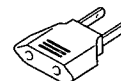

Power plug adaptor 1 pc.
[SJP5213-2 (GC)]

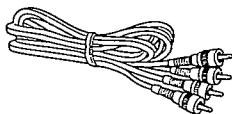

Stereo connection cable
[SJP2249-3]..... 1 pc.

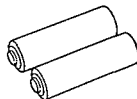

Batteries "AAA" (R03/UM-4)
for remote control transmitter .. 2 pcs.

Note: These are available on sale route.

BEFORE TRANSPORTING THE UNIT

To safeguard against damage in transit, be sure to secure the optical pickup by following the procedure below.

- 1 Remove the compact disc inside, and set the power switch to STANDBY \odot with the disc tray still open.**
- 2 Slowly push in the disc tray by hand.**
Do not tilt the unit while doing this.
If the disc tray is not pushed in slowly, the optical pick-up may not be secured properly.
- 3 Check that the lock mark can be seen in its entirety as shown in the figure on the right.**

The optical pickup will be automatically released when using the unit again.

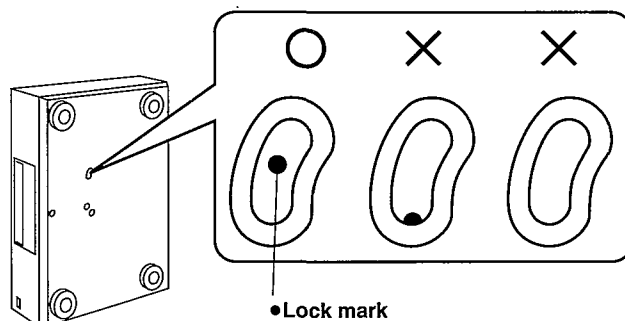

■ PRECAUTION OF LASER DIODE

CAUTION: This product utilizes a laser diode with the unit turned "on", invisible laser radiation is emitted from the pickup lens.
Wave length: 780nm
Maximum output radiation power from pickup: 100µW/VDE

Laser radiation from the pickup lens is safety level, but be sure the followings:

1. Do not disassemble the optical pickup unit, since radiation from exposed laser diode is dangerous.
2. Do not adjust the variable resistor on the pickup unit. It was already adjusted.
3. Do not look at the focus lens using optical instruments.
4. Recommend not to look at pickup lens for a long time.

ACHTUNG: Dieses Produkt enthält eine Laserdiode. Im eingeschalteten Zustand wird unsichtbare Laserstrahlung von der Lasereinheit abgestrahlt.

Wellenlänge: 780nm

Maximale Strahlungsleistung der Lasereinheit: 100µW/VDE

Die Strahlung an der Lasereinheit ist ungefährlich, wenn folgende Punkte beachtet werden:

1. Die Lasereinheit nicht zerlegen, da die Strahlung an der freigelegten Laserdiode gefährlich ist.
2. Den werkseitig justierten Einstellregler der Lasereinheit nicht verstellen.
3. Nicht mit optischen Instrumenten in die Fokussierlines blicken.
4. Nicht über längere Zeit in die Fokussierlinse blicken.

ADVASEL: I dette a apparat anvendes laser.

• Use of caution labels

Note: ○ Mark is used, × Mark is not used.

Areas	SQWD7	RQLS0021	RQLS0078
(EG)	○	○	○
(EB)	○	○	×
(GC)	○	○	×
(GN)	○	○	×

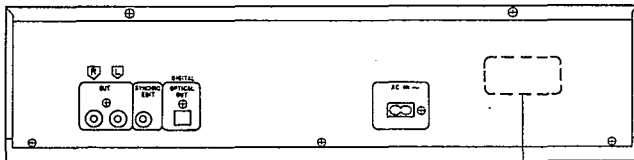

SQWD7



LUOKAN 1 LASERLAITE
KLASS 1 LASER APPARAT

RQLS0078

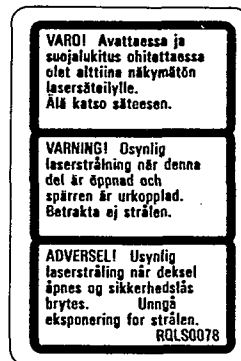

RQLS0021

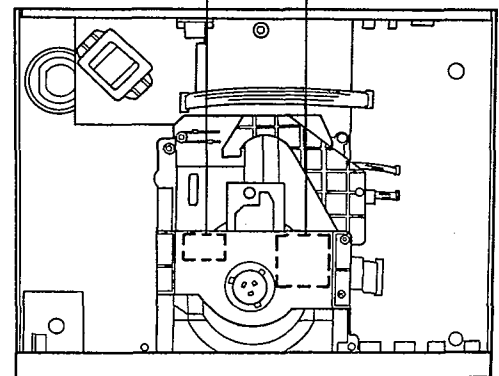

FRONT PANEL CONTROLS AND FUNCTIONS

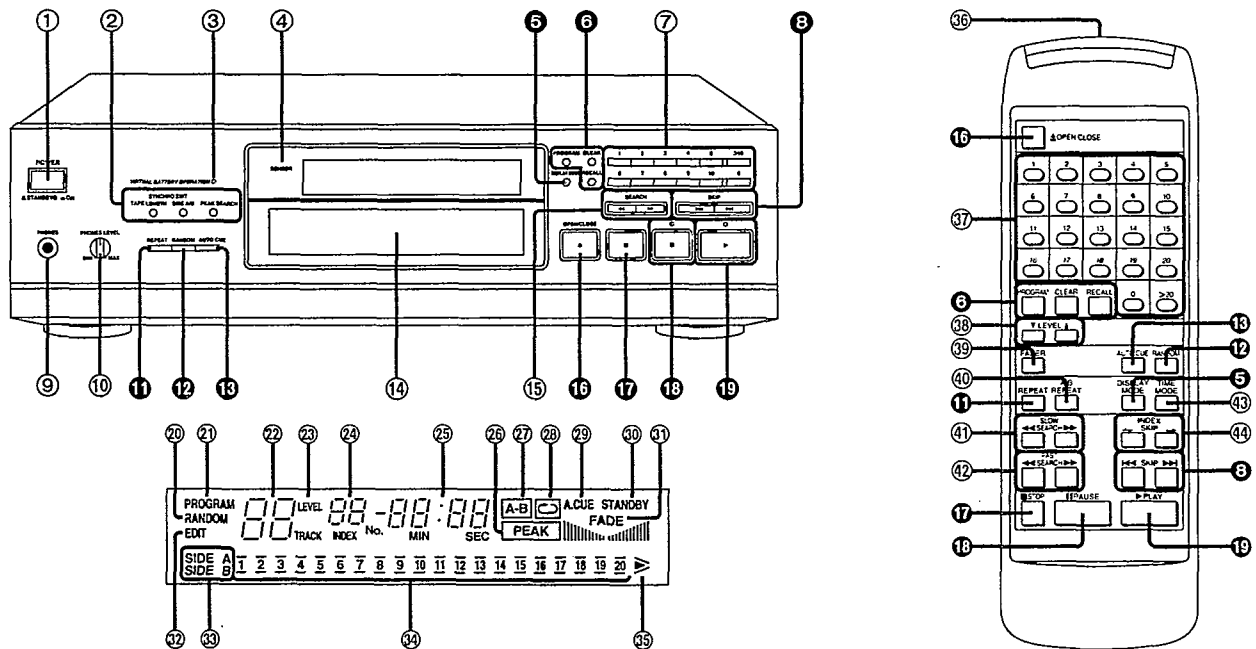

Control section

Numbers with black background (for example ⑤) indicate functions available on the remote control. (See page 5.)

- ① **Power “STANDBY \downarrow /ON” switch (POWER, \blacksquare STANDBY \downarrow ON)**
This switch switches ON and OFF the secondary circuit power only. The unit is in the “standby” condition when this switch is set to the STANDBY \downarrow position. Regardless of the switch setting, the primary circuit is always “live” as long as the power cord is connected to an electrical outlet.
- ② **Buttons for CD-Edit function**
 - Tape length button (TAPE LENGTH)
 - Tape side select button (SIDE A/B)
 - Peak search button (PEAK SEARCH)
- ③ **Virtual Battery Operation indicator (VIRTUAL BATTERY OPERATION)**
- ④ **Remote control signal sensor (SENSOR)**
- ⑤ **Display mode button (DISPLAY MODE)**
- ⑥ **Buttons for program function**
 - Program button (PROGRAM)
 - Recall button (RECALL)
 - Clear button (CLEAR)
- ⑦ **Numeric buttons (1–10, >10, 0)**
- ⑧ **Skip buttons (|◀◀ SKIP ▶▶|)**
- ⑨ **Headphones jack (PHONES)**
- ⑩ **Headphones volume control (PHONES LEVEL)**
- ⑪ **Repeat button (REPEAT)**
- ⑫ **Random button (RANDOM)**
- ⑬ **Auto cue button (AUTO CUE)**
- ⑭ **Disc tray**
- ⑮ **Search buttons (◀◀ SEARCH ▶▶)**
- ⑯ **Disc tray open/close button (\blacktriangle OPEN/CLOSE)**
- ⑰ **Stop button (\blacksquare)**
- ⑱ **Pause button and indicator (||)**
- ⑲ **Play button and indicator (\blacktriangleright)**

Display section

- ⑳ **Random play indicator (RANDOM)**
- ㉑ **Program indicator (PROGRAM)**
- ㉒ **Track number display**
- ㉓ **Level control indicator (LEVEL)**
- ㉔ **Index/program sequence display**
- ㉕ **Time display**
- ㉖ **Peak search indicator ($\boxed{\text{PEAK}}$)**
- ㉗ **A-B repeat indicator ($\boxed{\text{A-B}}$)**
- ㉘ **Repeat indicator ($\boxed{\text{REPEAT}}$)**
- ㉙ **Auto cue indicator (A.CUE)**
- ㉚ **Standby indicator (STANDBY)**
- ㉛ **Fade in/out indicator (FADE)**
- ㉜ **Compact disc edit indicator (EDIT)**
- ㉝ **Tape side indicator (SIDE A, SIDE B)**
- ㉞ **Track number indicator ($\boxed{1-20}$)**
- ㉟ **“Over” mark (\blacktriangleright)**

Remote control section

The functions ⑤, ⑥, ⑨, ⑪, ⑫, ⑬, ⑯, ⑰, ⑱ and ⑲ are described under "Control section" on page 4.

- ⑳ Remote control transmission window
- ㉑ Numeric buttons (1-20, 0, >20)
- ㉒ Level control buttons (▼ LEVEL ▲)
- ㉓ Fade in/out button (FADER)

- ㉔ A-B repeat button (A-B REPEAT)
- ㉕ Slow search button (◀◀ SLOW SEARCH ▶▶)
- ㉖ Fast search button (◀◀ FAST SEARCH ▶▶)
- ㉗ Time mode select button (TIME MODE)
- ㉘ Index skip button (◀ INDEX SKIP ▶)

CAUTION FOR AC MAINS LEAD

("EB" area code model only)

For your safety, please read the following text carefully.

This appliance is supplied with a moulded three pin mains plug for your safety and convenience.

A 5-ampere fuse is fitted in this plug.

Should the fuse need to be replaced please ensure that the replacement fuse has a rating of 5-ampere and that it is approved by ASTA or BSI to BS1362.

Check for the ASTA mark  or the BSI mark  on the body of the fuse.

If the plug contains a removable fuse cover you must ensure that it is refitted when the fuse is replaced.

If you lose the fuse cover the plug must not be used until a replacement cover is obtained.

A replacement fuse cover can be purchased from your local dealer.

CAUTION!

IF THE FITTED MOULDED PLUG IS UNSUITABLE FOR THE SOCKET OUTLET IN YOUR HOME THEN THE FUSE SHOULD BE REMOVED AND THE PLUG CUT OFF AND DISPOSED OF SAFELY.

THERE IS A DANGER OF SEVERE ELECTRICAL SHOCK IF THE CUT OFF PLUG IS INSERTED INTO ANY 13-AMPERE SOCKET.

If a new plug is to be fitted please observe the wiring code as shown below.

If in any doubt please consult a qualified electrician.

IMPORTANT

The wires in this mains lead are coloured in accordance with the following code:

Blue: Neutral

Brown: Live

As the colours of the wires in the mains lead of this appliance may not correspond with the coloured markings identifying the terminals in your plug, proceed as follows:

The wire which is coloured BLUE must be connected to the terminal in the plug which is marked with the letter N or coloured BLACK.

The wire which is coloured BROWN must be connected to the terminal in the plug which is marked with the letter L or coloured RED.

Under no circumstances should either of these wires be connected to the earth terminal of the three pin plug, marked with the letter E or the Earth Symbol .

Before use

Remove the connector cover as follows.

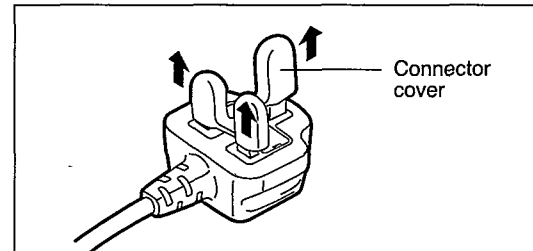

How to replace the fuse

1. Remove the fuse cover with a screwdriver.

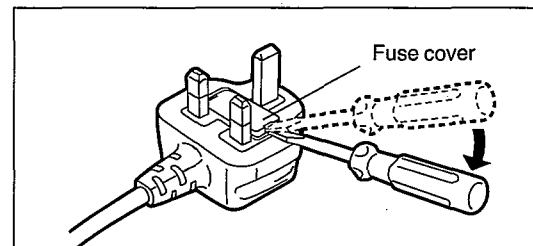

2. Replace the fuse and attach the fuse cover.

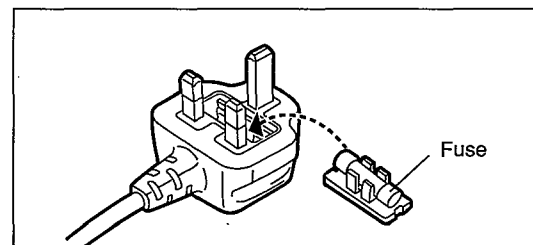

■ CONNECTIONS

Before making connections, be sure that the power of this unit and all other system components is first turned off. See the operating instructions of the amplifier or the cassette deck for details.

FOR UNITED KINGDOM ONLY
BE SURE TO READ THE CAUTION FOR AC POWER SUPPLY CORD ON PAGE 3 BEFORE PROCEEDING TO STEP 4.



LUOKAN 1 LASERLAITE KLASS 1 LASER APPARAT

Rear panel of this unit
 (Tutoteen takaosassa)
 (Apparatens baksida)

Note:
 The configuration of the AC outlet and AC power supply cord differs according to area.

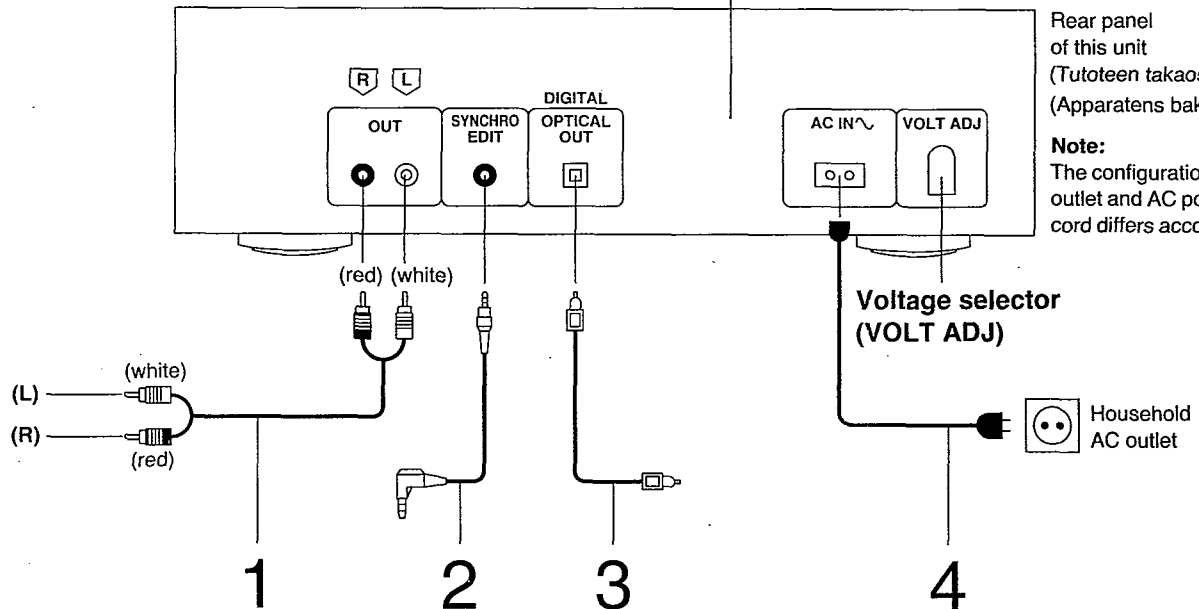

1 Connect the stereo connection cable (included) to the "CD" or "AUX" terminals of the amplifier.

When using the synchro edit function, be sure to connect the stereo connection cable to the amplifier even if the optical-fiber cable has been connected.

2 Connect the synchro edit cable (included with the cassette deck) to the "SYNCHRO EDIT" terminal of the Technics cassette deck.

3 Connect the optical-fiber cable (not included) to the "DIGITAL INPUT" terminal of the amplifier.

This terminal can be used for connection with other equipment that has a digital input terminal, such as an amplifier, by using an optical-fiber cable. A dust-protection cap is inserted in this terminal. Remove this cap only when a connection is to be made to this terminal.

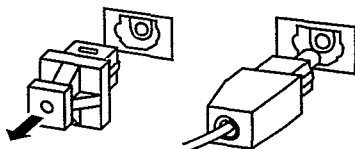

For (GC) area.

Set the voltage selector (VOLT ADJ) to the voltage setting for the area in which the unit will be used.

- Use a minus (-) screwdriver.
- Note that this unit will be seriously damaged if this setting is not made correctly.
- If the power supply in your area is 117 V or 120 V, set to the "127 V" position.

4 Connect the AC power supply cord (included) to the "AC OUTLET" of the amplifier or the household AC outlet.

For areas except Europe, Australia and New Zealand

If the power plug will not fit your socket, use the power plug adaptor (included).

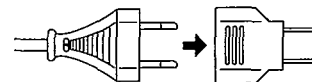

For areas except Australia and New Zealand
Insertion of Connector

Even when the connector is perfectly inserted, depending on the type of inlet used, the front part of the connector may jut out as shown in the drawing. However there is no problem using the unit.

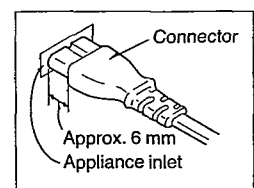

■ CONCERNING THE REMOTE CONTROL

Battery installation

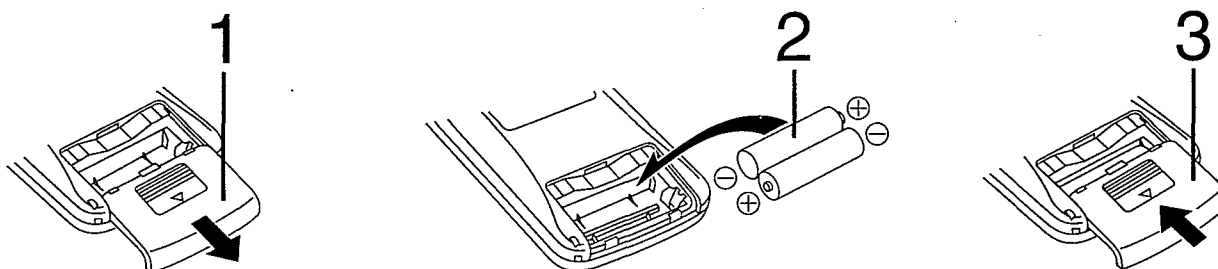

1 Open the cover.

Press gently and slide the cover out.

- Be sure to insert batteries so that their positive (+) and negative (-) polarities match the indications in the compartment. Batteries installed incorrectly may leak and cause damage.

2 Insert the batteries included with this unit.

- When you need to replace these batteries, use two UM-4 "AAA", IEC R03 (1.5 V) or equivalent batteries.

- Refer to "Use of batteries" below for additional information.

3 Close the cover.

Use of batteries

- Do not mix old and new batteries or batteries of different types (carbon and alkaline, etc.).
- The average battery life is about one year. Although the battery life varies depending on how often the device is used, you should generally replace the batteries about once a year.
- Replace the batteries if commands from the remote control transmitter do not operate the unit even when the transmitter is held close to the front panel.
- Never subject batteries to excessive heat or flame; do not attempt to disassemble them; and be sure they are not short-circuited.
- If you will not be using the remote control for a long period of time, remove the batteries and store in a cool, dark place.
- If a battery leaks, remove all batteries and dispose of them properly. Thoroughly clean the battery compartment before inserting new batteries.
- If the leaking electrolyte comes in contact with skin or clothes, flush with water immediately.
- Keep batteries out of reach of children.
- Do not use rechargeable-type (nickel-cadmium) batteries.
- Do not attempt to recharge alkaline or carbon batteries.
- Always remove old, weak, or worn-out batteries and dispose of them properly.
- Do not dispose of used batteries in household rubbish.

Operation notes

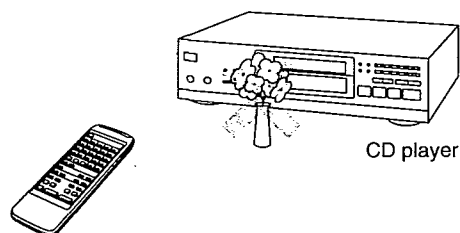

Aim the remote control's transmission window toward the CD player's sensor. Avoid any obstacles.

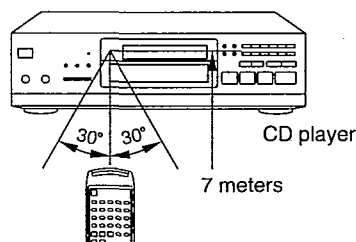
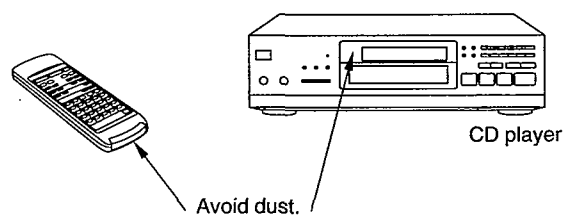

- Use the remote control with a 60-degree angle of the CD player.
- Maximum distance is within 7 meters directly facing toward the CD player.

- Be sure the transmission window and the CD player's sensor are free from dust. Excessive dust might prevent reception.
- If direct sunlight or another strong light source strikes the remote control signal sensor part of the CD player, it may impair the remote control's operation. If there is a problem, place the CD player away from the light source.
- If this unit is installed in a rack with glass doors, the glass doors' thickness or color might make it necessary to use the remote-control transmitter a shorter distance from the unit.

■ HANDLING PRECAUTIONS FOR OPTICAL PICKUP

The laser diode in the optical pickup may break down due to potential difference caused by static electricity of clothes or human body.

So, be careful of electrostatic breakdown during repair of the optical pickup.

• Handling of optical pickup

1. Do not subject the optical pickup to static electricity as it is extremely sensitive to electrical shock.
2. To prevent the breakdown of the laser diode, an antistatic shorting pin is inserted into the flexible board (FPC board).
When removing or connecting the short pin, finish the job in as short time as possible.
3. Take care not to apply excessive stress to the flexible board (FPC board).
4. Do not turn the variable resistor (laser power adjustment). It has already been adjusted.

• Grounding for electrostatic breakdown prevention

1. Human body grounding
Use the anti-static wrist strap to discharge the static electricity from your body.
2. Work table grounding
Put a conductive material (sheet) or steel sheet on the area where the optical pickup is placed, and ground the sheet.

Caution:

The static electricity of your clothes will not be grounded through the wrist strap. So, take care not to let your clothes touch the optical pickup.

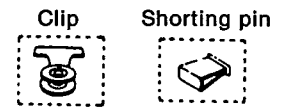

Be sure to short this position
(Use the shorting pin or clip.)

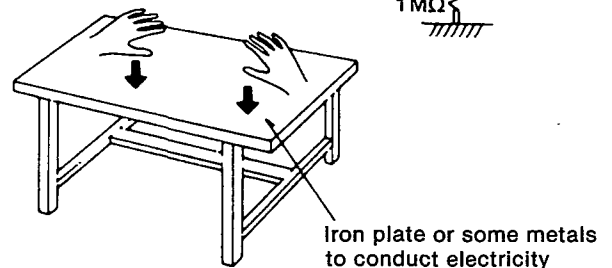
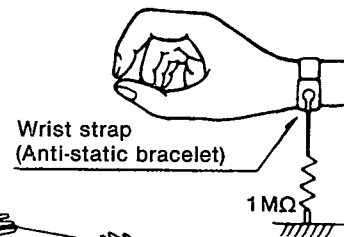
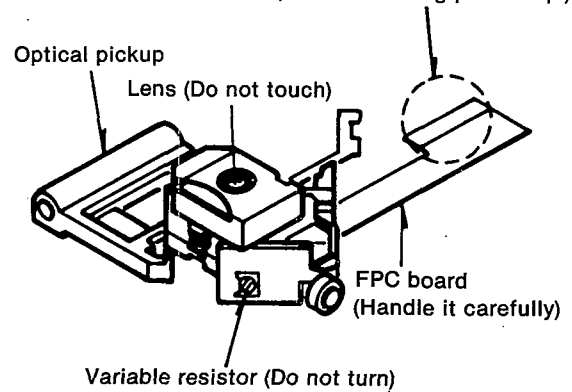

■ INSTRUCTIONS FOR TRAVERSE OIL (Part No. SZZ0L31)

The container contains 6g (approx. 3ml) of oil.
One application (one shaft) uses 0.05ml of oil.

How to Use

- (1) Remove the guide shaft in the traverse deck from the optical pickup and clean off any dust from the guide shaft.
- (2) Apply one drop of the SZZ0L31 to the tip of the guide shaft.
- (3) Hold the guide shaft so that its oiled end touches the optical pickup and insert it into the bearing while rotating it slowly.
- (4) After securing the guide shaft, move the optical pickup by hand several times to the left and right to distribute the oil on the guide shaft.

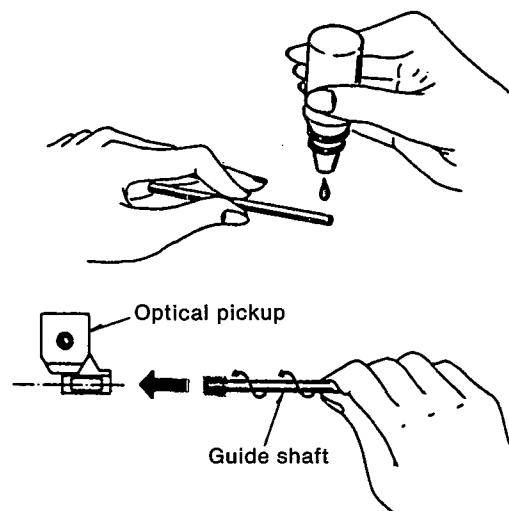

DISASSEMBLY INSTRUCTIONS

Warning: This product uses a laser diode. Refer to caution statements on page 3.

ACHTUNG: • Die lasereinheit nicht zerlegen.
• Die lasereinheit darf nur gegen eine vom hersteller spezifizierte einheit ausgetauscht werden.

※ This CD player is equipped with FPC boards, so handle them with care during disassembly and reassembly.

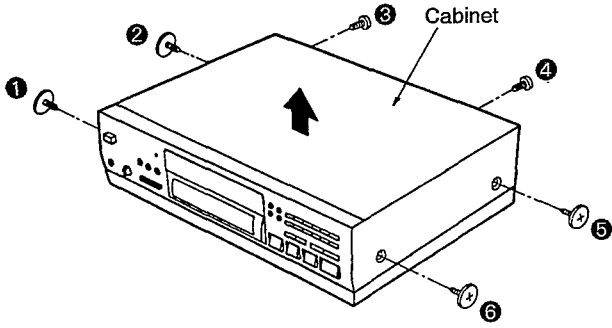
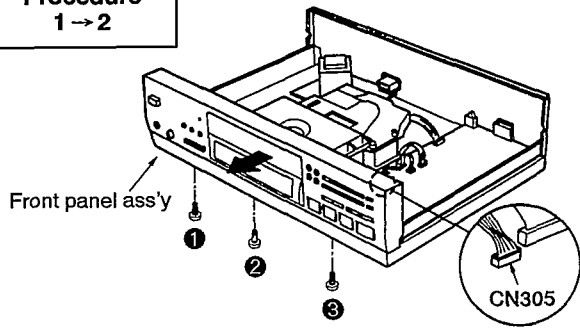
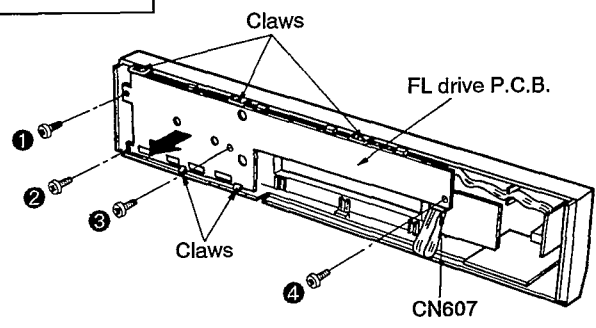
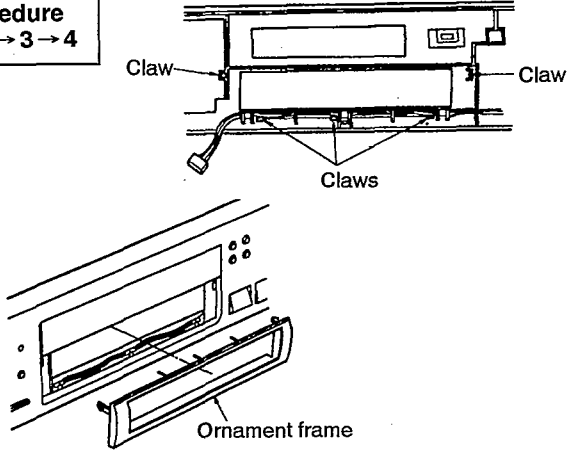
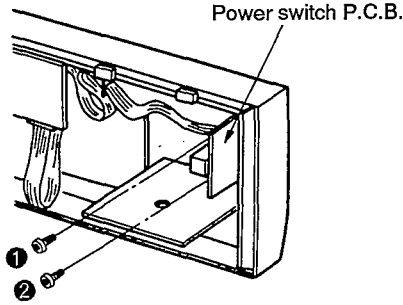
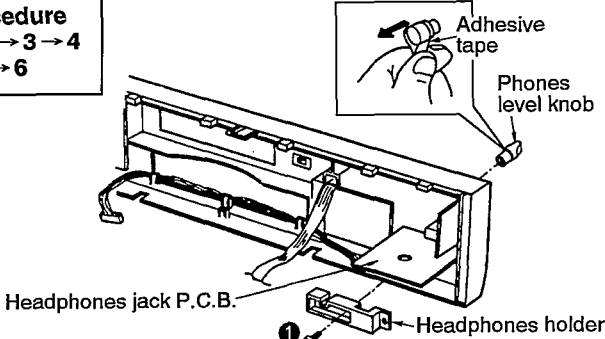
Ref.No. 1	Removal of the cabinet	Ref.No. 2	Removal of the front panel ass'y
Procedure 1	 <p>• Remove the 6 screws(①~⑥).</p>	Procedure 1→2	 <p>1. Remove the 1 connector(CN305). 2. Remove the 3 screws(①~③). 3. Remove the front panel ass'y in the direction of arrow.</p>
Ref.No. 3	Removal of the FL drive P.C.B.	Ref.No. 4	Removal of the ornament frame
Procedure 1→2→3	 <p>1. Remove the 1 connector(CN607). 2. Remove the 4 screws(①~④). 3. Release the 5 claws. 4. Remove the FL drive P.C.B. in the direction of arrow.</p>	Procedure 1→2→3→4	 <p>• Release the 5 claws.</p>
Ref.No. 5	Removal of the power switch P.C.B.	Ref.No. 6	Removal of the headphones jack P.C.B.
Procedure 1→2→5	 <p>• Remove the 2 screws(①, ②).</p>	Procedure 1→2→3→4 →6	 <p>1. Pull out the phones level knob. 2. Remove the 1 screw(①). 3. Remove the headphones holder.</p>

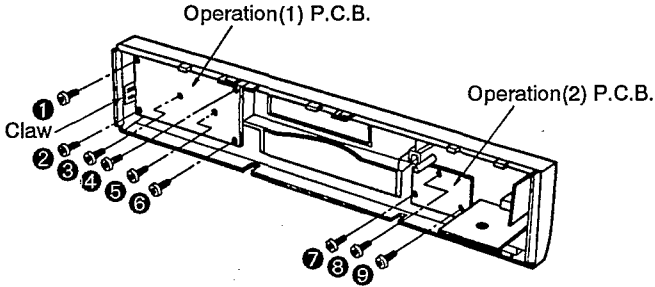
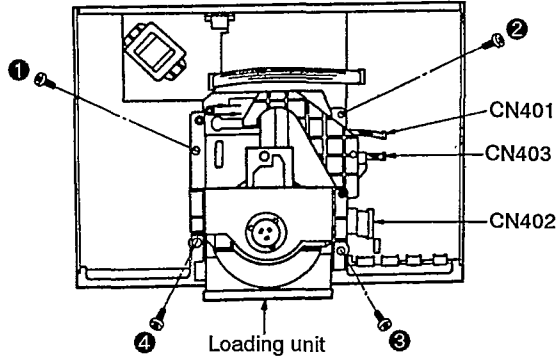
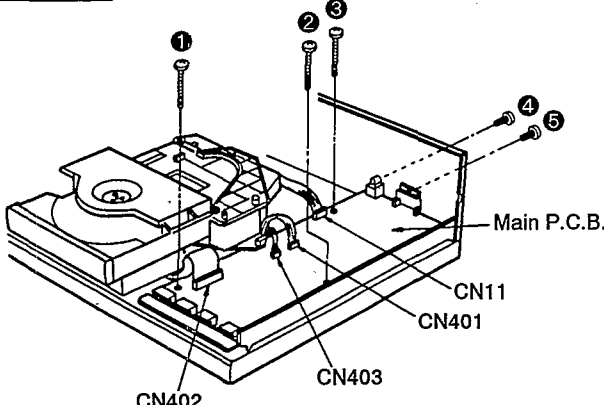
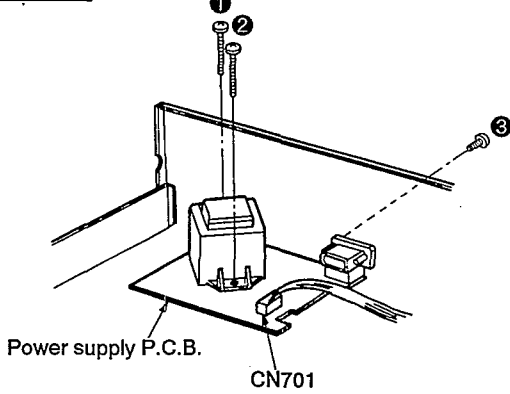
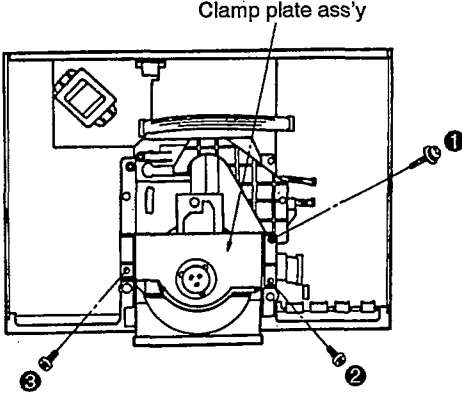
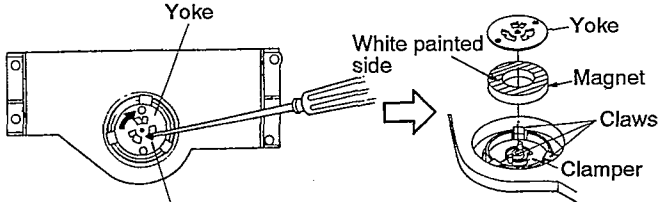
<p>Ref.No. 7</p>	<p>Removal of the operation(1) P.C.B. and operation(2) P.C.B.</p>	<p>Ref.No. 8</p>	<p>Removal of the loading unit</p>
<p>Procedure 1 → 2 → 3 → 7</p>		<p>Procedure 1 → 2 → 8</p>	
 <p>Operation(1) P.C.B. Operation(2) P.C.B. Claw</p> <p>1. Remove the 6 screws(❶ ~ ❹). 2. Release the 1 claw.</p> <p>■ Removal of the operation(2) P.C.B. • Remove the 3 screws(❷ ~ ❹).</p>		 <p>1. Remove the 3 flat cables(CN401, CN402, CN403). 2. Remove the 4 screws(❶ ~ ❹).</p>	
<p>Ref.No. 9</p>	<p>Removal of the main P.C.B.</p>	<p>Ref.No. 10</p>	<p>Removal of the power supply P.C.B.</p>
<p>Procedure 1 → 2 → 8 → 9</p>		<p>Procedure 1 → 10</p>	
 <p>1. Remove the 4 flat cables(CN11, CN401, CN402, CN403). 2. Remove the 5 screws(❶ ~ ❺).</p>		 <p>1. Remove the 1 flat cable(CN701). 2. Remove the 3 screws(❶ ~ ❸).</p>	
<p>Ref.No. 11</p>	<p>Removal of the clamp plate ass'y</p>	<p>Ref.No. 12</p>	<p>Removal of the yoke, magnet and clamber</p>
<p>Procedure 1 → 2 → 11</p>		<p>Procedure 1 → 2 → 11 → 12</p>	
 <p>• Remove the 3 screws(❶ ~ ❸).</p>		 <p>1. While lifting the claw with a screwdriver, rotate yoke in the direction of arrow and remove the yoke and magnet. 2. Release the 3 claws of the clamber.</p>	

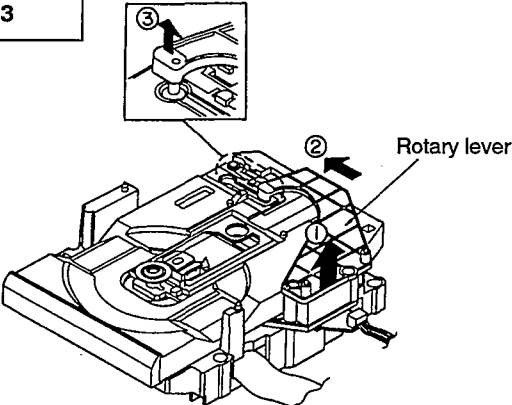
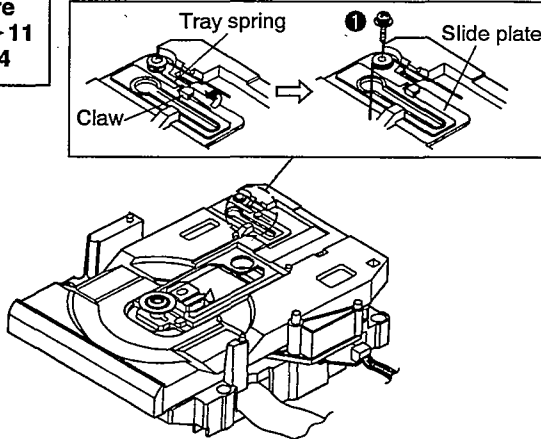
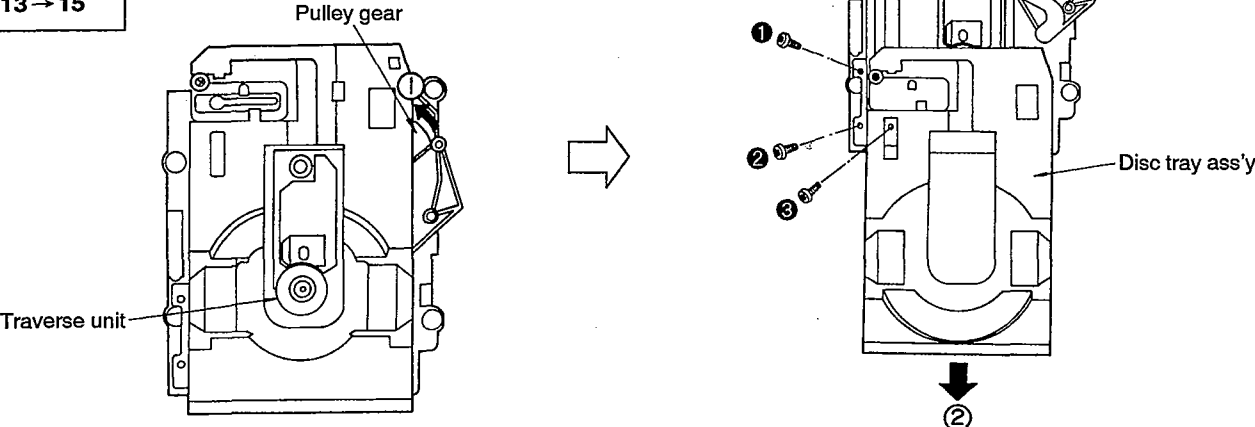
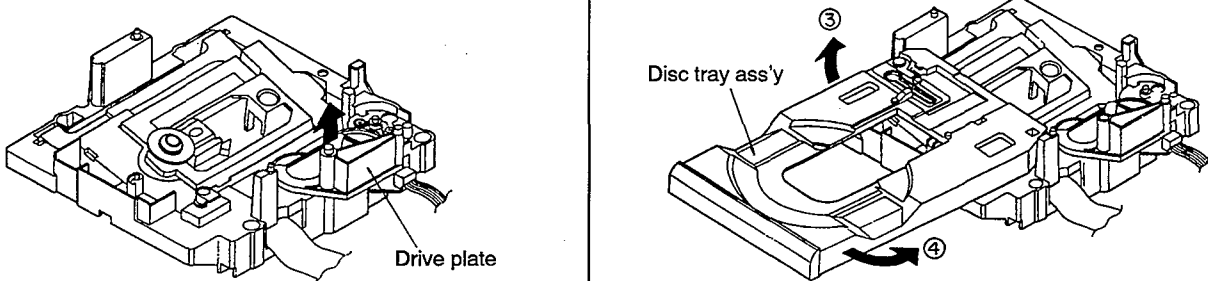
<p>Ref.No. 13</p>	<p>Removal of the rotary lever</p>	<p>Ref.No. 14</p>	<p>Removal of the slide plate</p>
<p>Procedure 1 → 2 → 8 → 11 → 13</p>	 <p>Rotary lever</p> <ul style="list-style-type: none"> Remove the rotary lever in the directions of arrows ①, ② and ③. 	<p>Procedure 1 → 2 → 8 → 11 → 13 → 14</p>	 <p>Tray spring Slide plate Claw</p> <ol style="list-style-type: none"> Remove the tray spring from the claw. Remove the 1 screw(①). Remove the tray spring and slide plate.
<p>Ref.No. 15</p>	<p>Removal of the disc tray ass'y</p>	 <p>Pulley gear Disc tray ass'y Disc tray ass'y</p> <ol style="list-style-type: none"> Turn the pulley gear in the direction of arrow ① until the traverse unit comes down. Pull the disc tray ass'y in the direction of arrow ②. Remove the 3 screws(① ~ ③). 	
<p>Ref.No. 16</p>	<p>Removal of the drive plate</p>	 <p>Drive plate Disc tray ass'y</p> <ol style="list-style-type: none"> Remove the drive plate in the direction of arrow. Remove the disc tray ass'y in the direction of arrows ③, ④. 	

Ref.No. 17	Removal of the traverse unit	<div data-bbox="226 291 678 593" data-label="Image"> </div> <div data-bbox="858 235 1324 604" data-label="Image"> </div> <div data-bbox="108 678 754 734" data-label="Text"> <p>1. Rotate the pulley gear in the direction of arrow ① until the traverse unit comes up.</p> </div> <div data-bbox="810 678 1412 734" data-label="Text"> <p>2. Remove the 1 screw (①). 3. Remove the traverse unit in the direction of arrow ②.</p> </div>
Ref.No. 18	Removal of the servo P.C.B.	<div data-bbox="108 835 280 891" data-label="Text"> <p>Procedure 1 → 2 → 8 → 18</p> </div> <div data-bbox="108 958 702 1048" data-label="List-Group"> <ol style="list-style-type: none"> 1. Remove the 3 screws (① ~ ③). 2. Unsolder the 2 terminals of spindle motor. 3. Remove the FPC board from the connector (CN101). </div> <div data-bbox="108 1075 702 1160" data-label="Text"> <p>Caution: To prevent the breakdown of the laser diode, antistatic shorting pin should be inserted into the FPC board.</p> </div> <div data-bbox="268 1176 534 1344" data-label="Image"> </div> <div data-bbox="853 884 1436 1288" data-label="Image"> </div>
Ref.No. 19	Removal of the optical pickup	<div data-bbox="108 1462 280 1541" data-label="Text"> <p>Procedure 1 → 2 → 8 → 18 → 19</p> </div> <div data-bbox="311 1500 766 1601" data-label="Text"> <p>Refer to the handling precautions on page 8 for guide shaft greasing when installing the optical pickup.</p> </div> <div data-bbox="108 1686 678 1742" data-label="List-Group"> <ol style="list-style-type: none"> 1. Remove the 2 screws (①, ②). 2. Unsolder the 2 terminals and the 2 screws (③, ④). </div> <div data-bbox="108 1769 678 1803" data-label="Text"> <p>Caution: Take care not to touch the brush terminal.</p> </div> <div data-bbox="869 1489 1436 1904" data-label="Image"> </div>

Ref.No. 20 **Removal of the spindle motor**

Procedure
 1 → 2 → 8 → 11
 → 13 → 15 → 16
 → 17 → 18 → 20

1. Loosen the 1 screw (❶) by using a 1.27mm allen wrench and remove the turntable.
2. Remove the 2 screws (❷, ❸).

Caution:

1. Turntable height adjustment is necessary any time the turntable or spindle motor is replaced.
2. The (+)terminal of the spindle motor is indicated by the red mark.

● Adjustment of turntable height

1. Insert a 0.9mm clearance gauge (RZZ0297) between the turntable and loading base as shown in the figure.
2. Tighten the turntable set-screw by using a 1.27mm allen wrench.

Caution:

Refer to turntable height adjustment (See page 21).

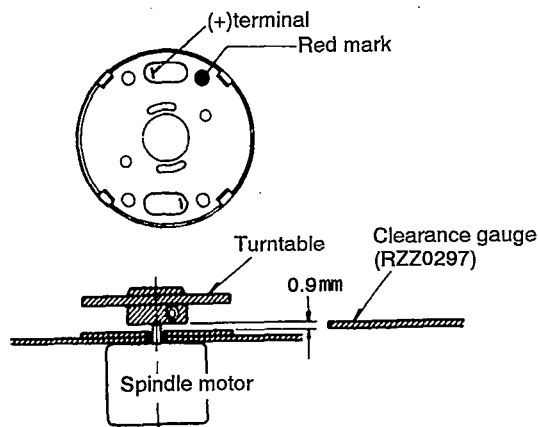
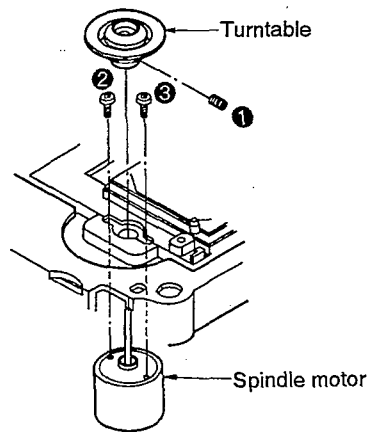

Ref.No. 21 **Removal of the loading motor ass'y**

Procedure
 1 → 2 → 8 → 11
 → 13 → 15 → 16
 → 21

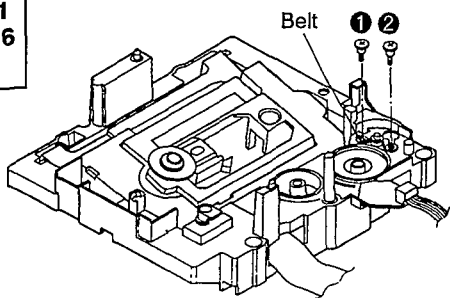

1. Remove the belt.
2. Remove the 2 screws (❶, ❷).

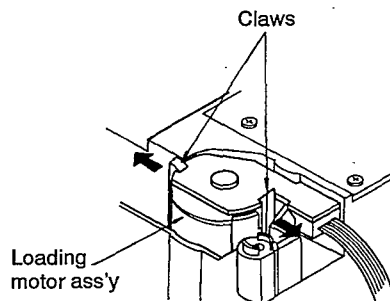

3. Release the 2 claws and then remove the loading motor ass'y.

Ref.No. 22 **Removal of the switch P.C.B.**

Procedure
 1 → 2 → 8 → 11
 → 13 → 15 → 16
 → 22

1. Remove the 1 screw (❶).
2. Release the 2 claws and then remove the switch P.C.B.

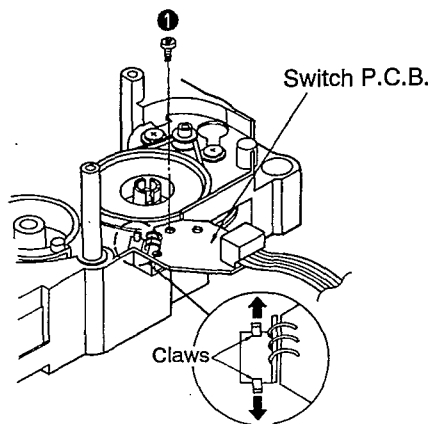

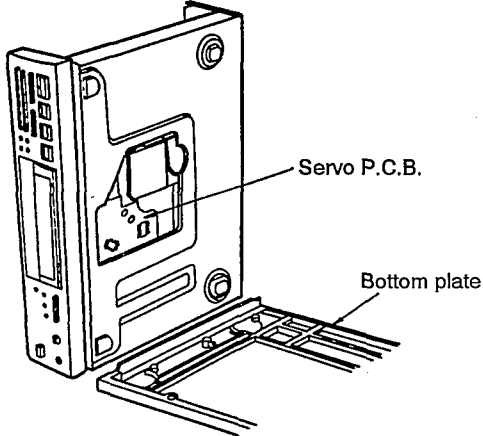
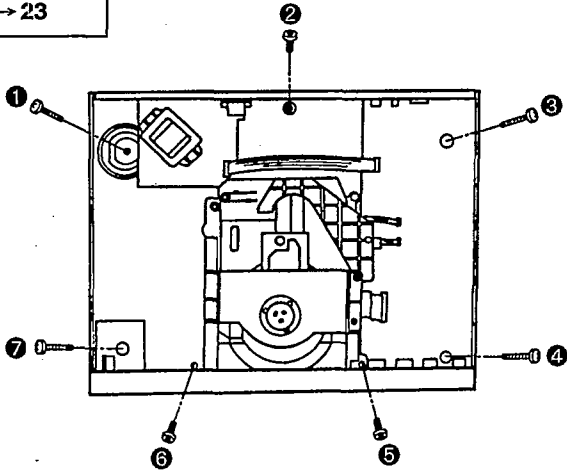
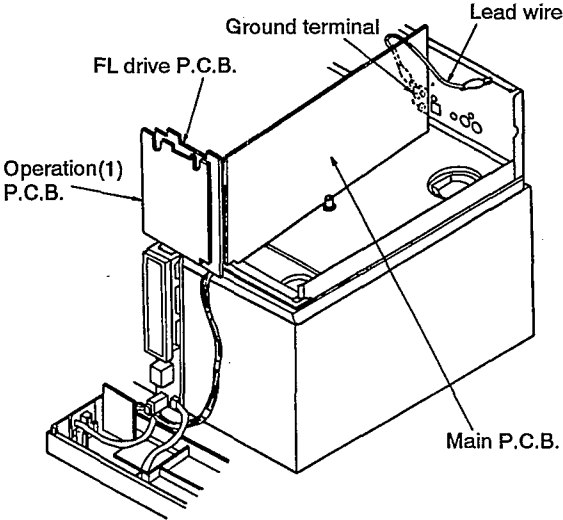
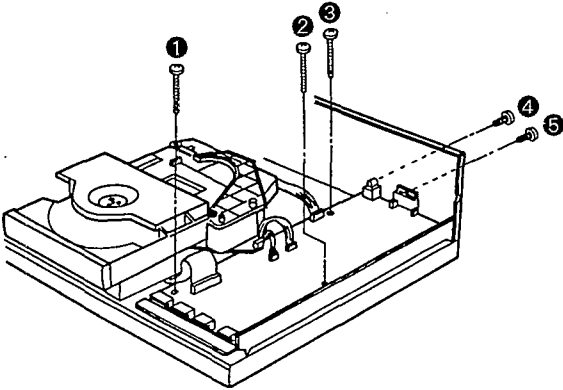
<p>Ref.No. 23</p>	<p>How to check the servo P.C.B.</p>	 <p>Servo P.C.B.</p> <p>Bottom plate</p>
<p>Procedure 1 → 23</p>	 <ol style="list-style-type: none"> 1. Remove the 7 screws (①~⑦). 2. Remove the bottom plate and then place the unit sideways. 3. When checking the servo P.C.B., do as shown above. 	
<p>Ref.No. 24</p>	<p>How to check the main P.C.B.</p>	 <p>Ground terminal</p> <p>Lead wire</p> <p>FL drive P.C.B.</p> <p>Operation(1) P.C.B.</p> <p>Main P.C.B.</p>
<p>Procedure 1 → 2 → 3 → 4 → 7 → 24</p>	 <ol style="list-style-type: none"> 1. Remove the 5 screws (①~⑤). 2. Place the main P.C.B. sideways and then install the operation (1) P.C.B. and the FL drive P.C.B. on the main P.C.B. 3. Connect the ground terminal(LINE OUT TERMINAL) of the main P.C.B. to the chassis with lead wire. 4. When checking the solder surface of the main P.C.B., do as shown above. 	

■ DISPLAY FUNCTION OF AUTOMATICALLY-ADJUSTED RESULTS (SELF-CHECK FUNCTION)

The unit contains a function which displays the result of the automatically adjustment of the servo circuits (tracking, focus servo, etc.) as an error code on the FL display.

The error code display serves as a repair guide showing the automatically adjustment circuit is at fault. The procedures for displaying the error codes are given below.



• Procedures to display the error code



- (1) While simultaneously pressing and holding the three keys, **STOP**, **PAUSE**, and **PLAY**, press the **POWER** key. When the unit is turned on and the FL display is lit up, immediately release the three keys.
- (2) Press the **OPEN/CLOSE** key to open the disc tray, load the test disc (SZZP1054C) on the tray, close the tray by pressing the **OPEN/CLOSE** key again. An error code will appear on the FL display (e.g. "E-00").
- (3) The error code provides a rough indication of which servo circuit is malfunctioning.

• Error code based troubleshooting

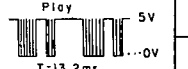
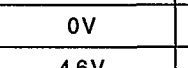
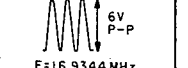
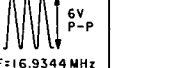
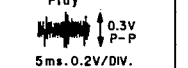
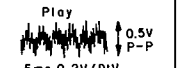
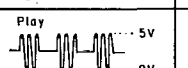
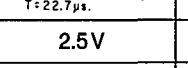
※ The unit is satisfactory if the error code is E-00 of E-02.

※ Before testing, check that the test disc is free of scratches and dirt and optical pickup is clean.

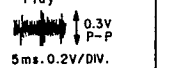
FL error code display	Symptom	Probable cause	Signal to check		Normal the values of voltage and waveform	
			Signal name	Location	PLAY	STOP
E-01	Incomplete focus, tracking or offset adjustment	1. Data transfer with IC401 2. IC102 setup condition	MDATA	IC102 ⑦ pin		4.7V
			MCLK	IC102 ⑧ pin		4.6V
			MLD	IC102 ⑨ pin		4.7V
			SENSE	IC102 ⑩ pin	0V	4.9V
			/RST	IC102 ⑪ pin	4.6V	4.6V
			XI	IC102 ⑫ pin		
E-03 E-05 E-07 E-09 E-11 E-13 E-15	Disc cannot be played reliably.	1. Scratched or dirty disc 2. Focus and tracking servo circuits 3. Spindle drive circuit 4. Optical pickup	FE	IC102 ⑬ pin		2.4V
			TE	IC102 ⑭ pin		2.5V
			FOD	IC102 ⑮ pin		2.5V
			TRD	IC102 ⑯ pin		
			KICK	IC102 ⑰ pin	2.5V	2.5V
			VR1	IC102 ⑱ pin	3.9V	3.9V
			VR2	IC102 ⑲ pin	0.9V	0.9V
			/FLOCK	IC102 ⑳ pin	0V	4.9V
			/RF DET	IC102 ㉑ pin	0V	4.7V
			RF	TJ101		2.5V
			STAT	IC301 ① pin	4.9V	0V

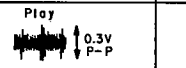
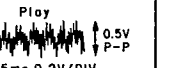
FL error code display	Symptom	Probable cause	Signal to check		Normal the values of voltage and waveform	
			Signal name	Location	PLAY	STOP
E-04 E-06	Incomplete focus gain adjustment	1. Scratched or dirty disc 2. Focus servo circuit 3. Optical pickup	FE	IC102 ⑬ pin		2.4V
			VR1	IC102 ⑱ pin	3.9V	3.9V
			VR2	IC102 ⑲ pin	0.9V	0.9V
			OFT	IC102 ⑳ pin	0V	4.7V
			/TLOCK	IC102 ㉑ pin	0V	4.9V
E-08 E-10 ※ See note	Incomplete tracking gain adjustment	1. Scratched or dirty disc 2. Tracking servo circuit 3. Optical pickup	TE	IC102 ⑭ pin		2.5V
			VR1	IC102 ⑱ pin	3.9V	3.9V
			VR2	IC102 ⑲ pin	0.9V	0.9V
			OFT	IC102 ⑳ pin	0V	4.7V
			/TLOCK	IC102 ㉑ pin	0V	4.9V
E-12 E-14	See error codes E-04, E-06, E-08 and E-10	See error codes E-04, E-06, E-08 and E-10	FE	IC102 ⑬ pin		2.4V
			TE	IC102 ⑭ pin		2.5V
			VR1	IC102 ⑱ pin	3.9V	3.9V
			VR2	IC102 ⑲ pin	0.9V	0.9V
			OFT	IC102 ⑳ pin	0V	4.7V
			/TLOCK	IC102 ㉑ pin	0V	4.9V

※ Note: For a unit showing error code E-08 or E-10, check the error code several times. If error code E-00 or E-02 appears, the unit can be assumed to be satisfactory.

DIGITAL SERVO SYSTEM

The newly-developed digital servo system is adopted in the servo circuit of the unit's CD player instead of the ordinary analog servo system.

- The diagrams shown below represent differences between the analog servo and digital servo systems. The HEAD AMP. output signals (i.e., focus error and tracking error output signals) are analog. These analog signals are converted to the 8-bit digital signals through the MN6650A. The MN6650A performs the following adjustments automatically; focus offset, tracking offset, focus gain, tracking gain, and tracking balance adjustments. The outputs from the MN6650A such as the focus coil driving signal, tracking coil driving signal, and traverse motor driving signal are converted to analog signals again and sent to the coils and motor to perform proper servo control for a disc.

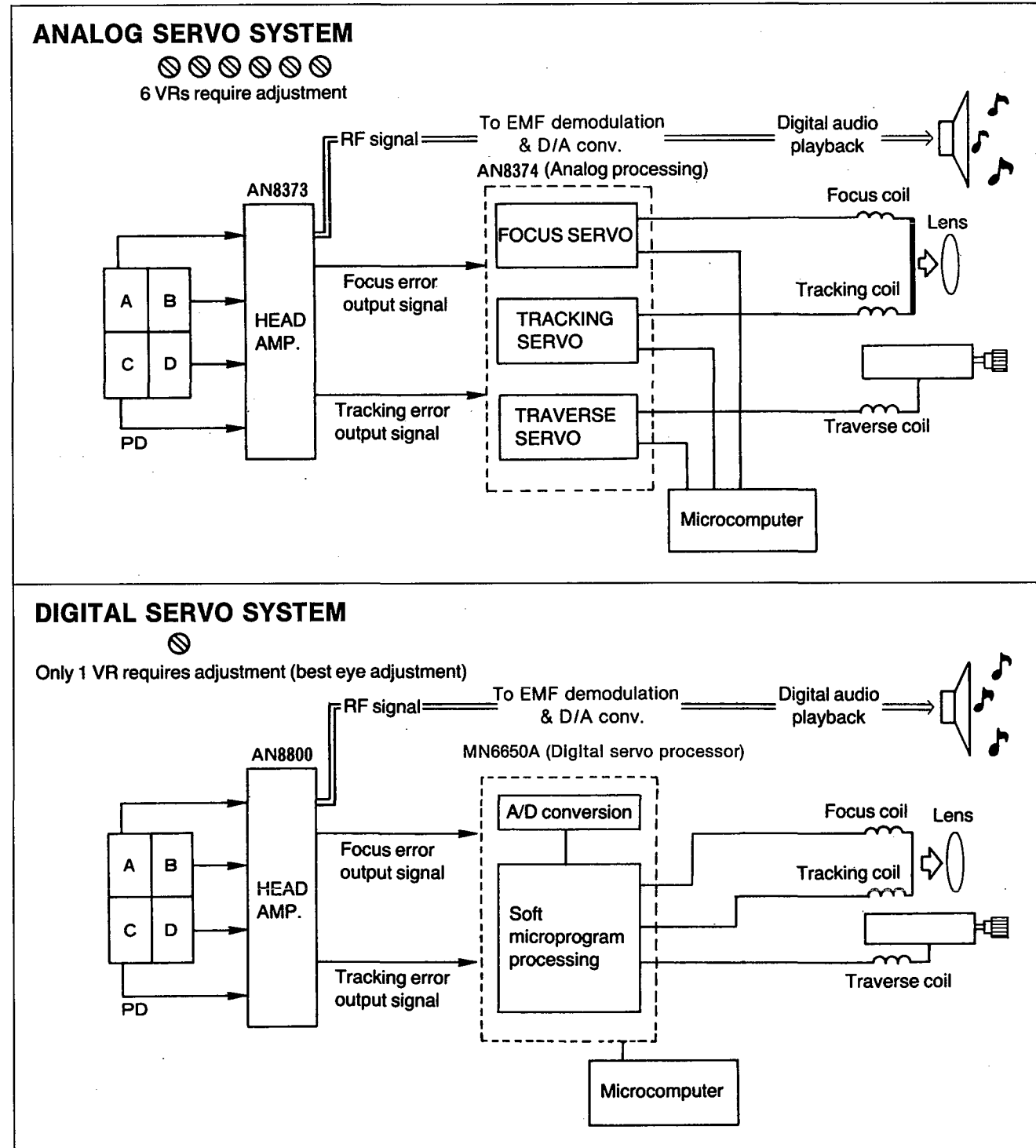

- The servo processor IC (MN6650A) of the newly-developed digital servo circuit automatically performs the following adjustments which were originally adjusted manually in the conventional analog servo circuit: (1) Focus offset, (2) Tracking offset, (3) Focus gain, (4) Tracking gain, and (5) Tracking balance. Therefore, you do not have to perform the above-mentioned electrical adjustments. The unit optimizes the servo for each loaded disc. [You must perform the best eye (PD balance) adjustment manually.]

The following flow chart shows the sequence of automatic adjustments.

Flow chart on automatic adjustment sequence

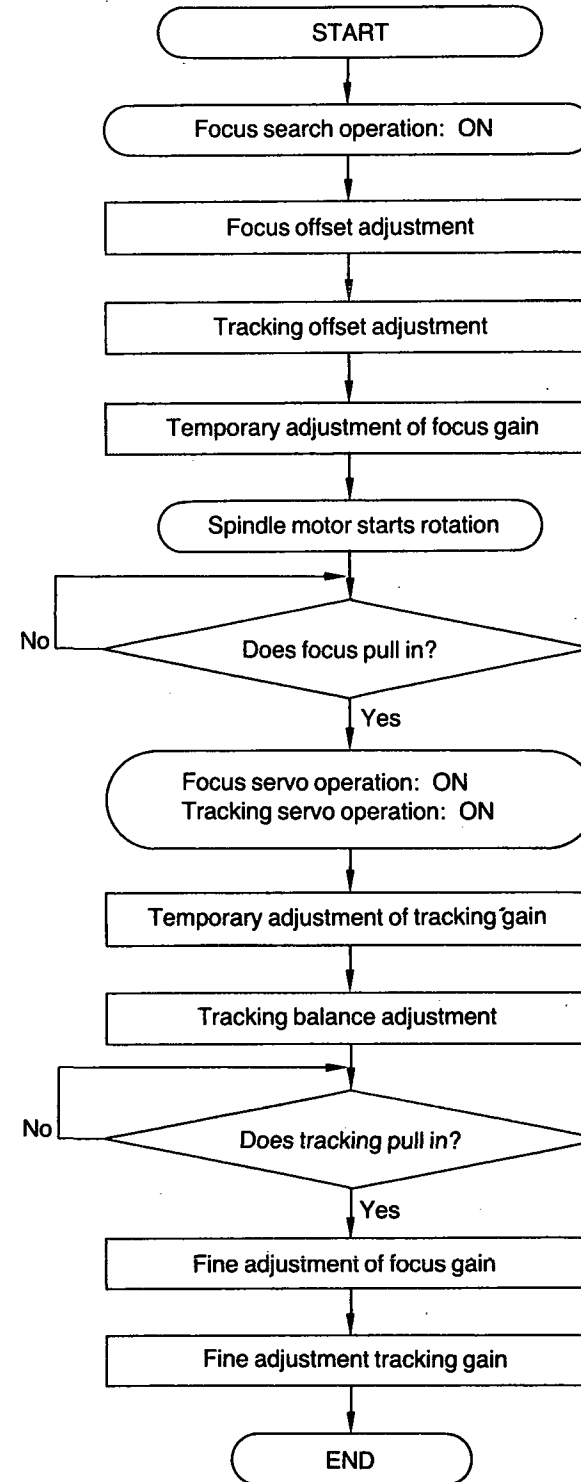

*Because the microcomputer precisely performs automatic adjustments as shown in the flow chart, it will take approx. 5 seconds to finish reading TOC data if a used disc is eccentric one or its surface is warped.

Approx. 2.5 sec.

■ TROUBLESHOOTING GUIDE

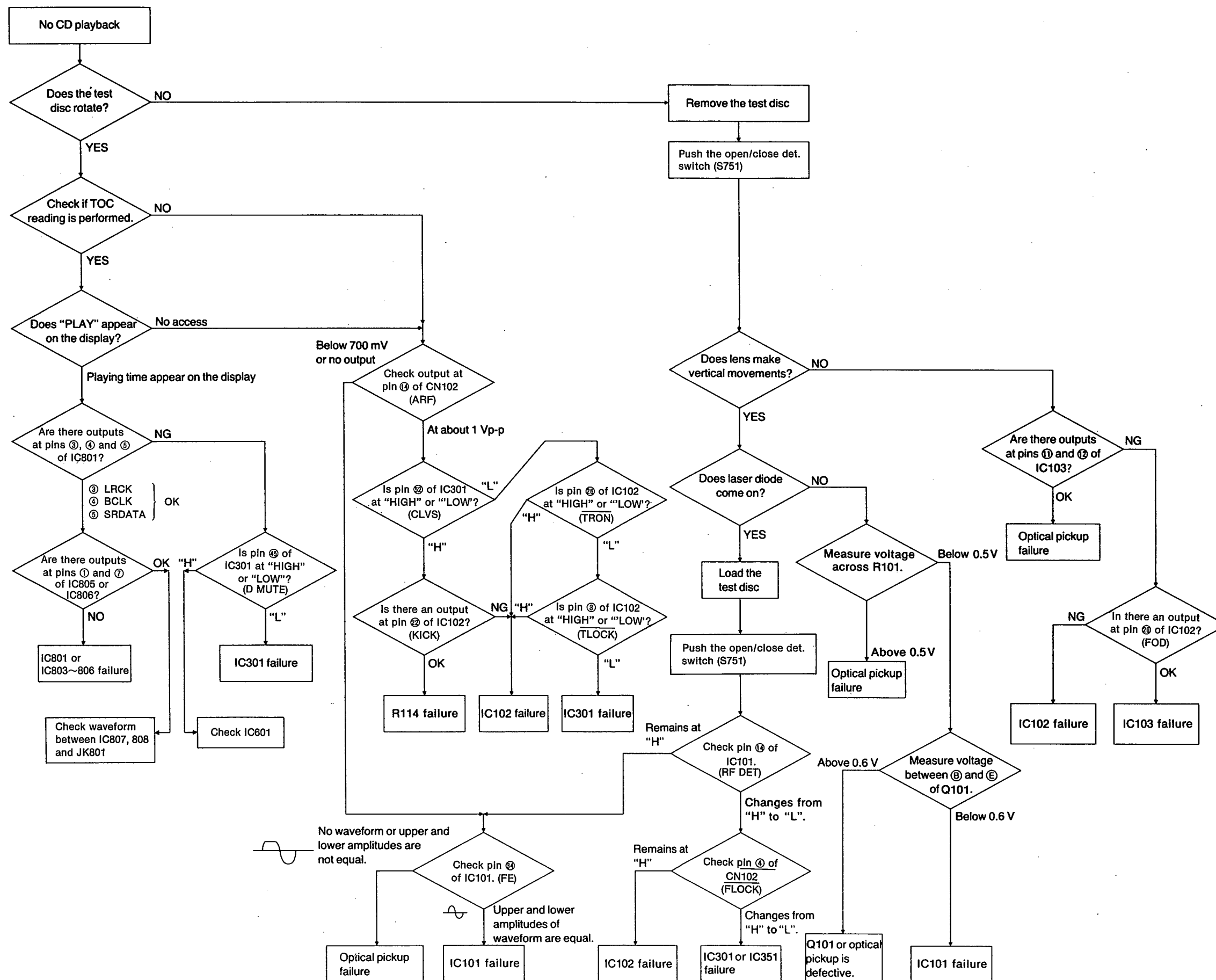

MEASUREMENTS AND ADJUSTMENTS

Warning: This product uses a laser diode. Refer to caution statements on page 2.

Measuring Instruments and Special Tools

- | | |
|---|-----------------------------------|
| * Test discs | * Allen wrench (M2.0) (SZZP1101C) |
| 1. Playability test disc (SZZP1054C) | * Allen wrench (M1.27) |
| 2. Uneven test disc (SZZP1056C) | * 0.9mm clearance gauge (RZZ0297) |
| * Musical program disc (ordinary) | * Filter |
| * Dual-beam oscilloscope with bandwidth of 30MHz or better (with EXT. trigger and 1:1 probe). | * Lock paint (RZZ0L01) |

PREPARATION

1. Remove the cabinet and front panel ass'y (See Ref. No. 1, 2 of the disassembly instructions).
2. Remove the clamp plate ass'y, yoke, magnet and clasper (see Ref. No. 11, 12 of the same).
3. Remove the rotation lever, disc tray ass'y and drive plate (see Ref. No. 13, 15, 16 of the same).
4. Attach the front panel ass'y to the unit.
5. Turn the pulley gear fully in the direction of arrow until traverse unit comes up.
6. Place the test disc and fix it by using the yoke, magnet and clasper.
7. Power switch to ON.
8. While pushing the open/close det. switch (S751) in the direction of arrow, push the play switch.

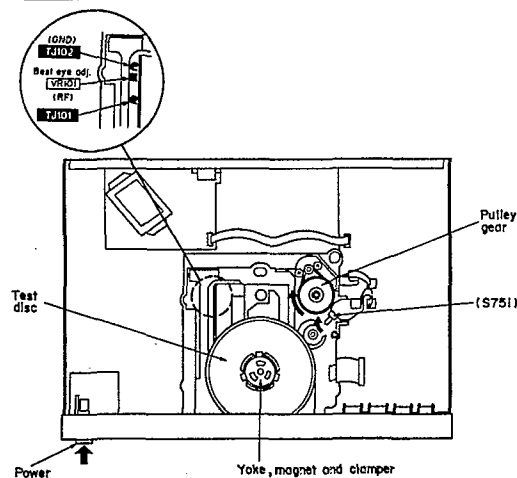

Fig. 1

Adjusting Procedure

* If you have replaced the optical pickup, spindle motor, or turntable, do the following adjustment:

(1) TURNTABLE HEIGHT ADJUSTMENT

1. Insert the 0.9mm clearance gauge (RZZ0297) between the turntable and the loading base. (Refer to Fig. 2).
2. Tighten the turntable retention screw with the 1.27mm allen wrench.
3. Connect the oscilloscope's CH. 1 probe across TP1 (+) and TP2 (-) terminal via a filter (Refer to Fig. 3).

Note: For the connection of oscilloscope's CH. 1 probe to servo P.C.B. on foil side, refer to fig. 2.

Oscilloscope setting: VOLT 500mV
SWEEP 5ms.
Input coupling..... DC

4. Adjust oscilloscope's DC zero balance.
5. Switch the play power ON, and play the test disc (SZZP1054C).
6. Measure the voltage amplitude of the signal on the oscilloscope.

7. Adjust the height until the voltage is $0 \pm 1.0V$.
If the voltage exceeds $+1.0V$, lower turntable.
If the voltage is below $-1.0V$, elevate the turn table.

Note: Measure the voltage as 0V as possible.

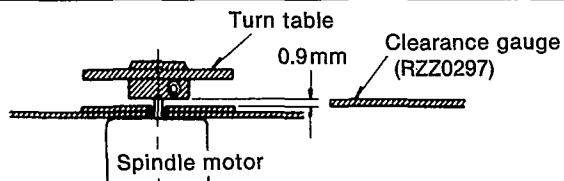

Fig. 2

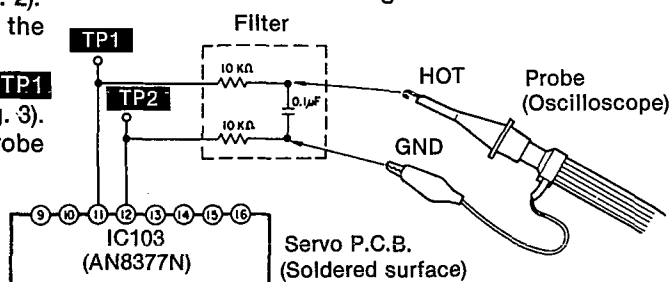
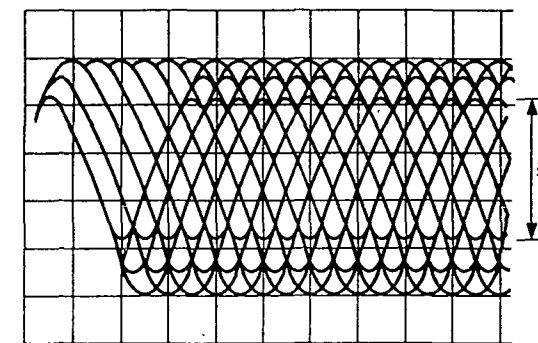

Fig. 3

(2) MECHANICAL ADJUSTMENT

1. Connect the oscilloscope's CH. 1 probe across TJ101 (+) and TJ102 (GND) on the servo P.C.B. (Refer to Fig. 1)
Oscilloscope setting: VOLT 100mV
SWEEP 0.5μs.
Input coupling..... AC
2. Switch the player power ON, and play track 7 on the test disc (SZZP1056C). (Playing any other track will prevent the HEX screws from being accessed.)
3. Leave the player in play mode and place it as shown Fig. 5.
4. Alternately adjust the HEX screws with the 2.0mm allen wrench (SZZP1101C) until the vertical fluctuation of RF signal is minimized and the eye pattern is most stretched. (Refer to Fig. 4)
5. After completing the adjustment, lock the HEX screws with lock paint (RZZ0L01).



※ Most stretched eye pattern.

Fig. 4

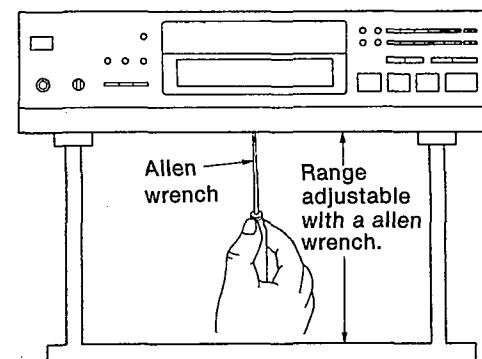
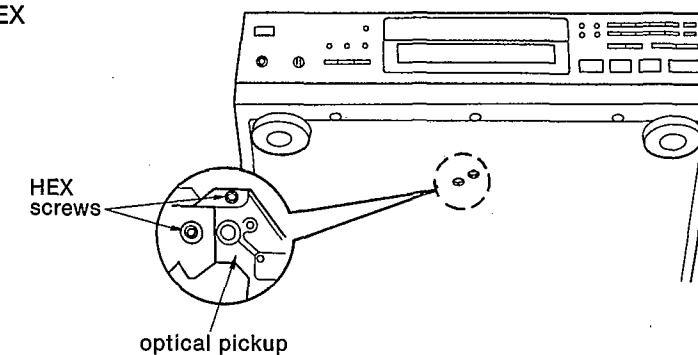
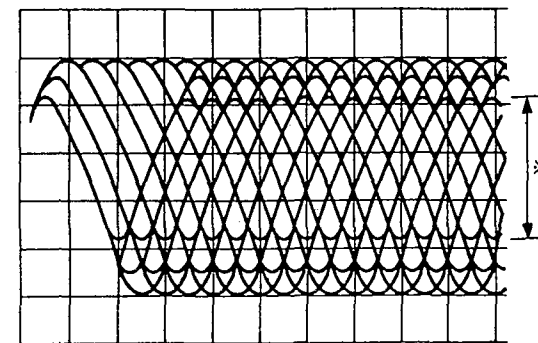

Fig. 5



(3) BEST EYE (PD BALANCE) ADJUSTMENT

1. Connect the oscilloscope's CH. 1 probe across TJ101 (+) and TJ102 (GND) on the servo P.C.B. (Refer to Fig. 1)
Oscilloscope setting: VOLT 100mV
SWEEP 0.5μs.
Input coupling..... AC
2. Switch the player power ON, and play the 1kHz (track 1) on the test disc (SZZP1054C).
3. Adjust VR101 until the vertical fluctuation of RF signal is minimized and the eye pattern is most stretched. (Refer to Fig. 6)



※ Most stretched eye pattern.

Fig. 6

(4) CHECK OF PLAY OPERATION AFTER ADJUSTMENT

* Checking Skip Search

1. Play an ordinary musical program disc.
2. Press the skip button to check for normal skip search operation (in both the forward and reverse directions).

* Checking Manual Search

1. Play an ordinary musical program disc.
2. Press the manual search button to check for smooth manual search operations at either low or high speed (in both the forward and reverse directions).

* Checking Playability

1. Play the 0.7mm black dot and the 0.7mm wedge on the playability test disc (SZZP1054C) and verify that no sound skip or noise occurs.
2. Play the middle tracks of the uneven test disc (SZZP1056C) and verify that no sound skip or noise occurs.

■ TERMINAL FUNCTION OF IC'S

• IC101 (AN8800SCE2): Servo amp

Pin No.	Mark	I/O Division	Function
1	LDG	I	APC loop gain select
2	LDP	I	APC monitor PD polarity select (Not used, open)
3	LD	O	Laser power auto control output
4	LPD	I	LD power monitor PD signal
5	GND	—	GND terminal
6	LDON	I	LD APC ON/OFF ("H": ON, "L": OFF)
7	AMP I	I	RF signal (X30 amp)
8	AMP O	O	
9	RF IN	I	RF AGC signal input
10	RF EQ	—	GND terminal
11	C. AGC	I	AGC detection capacitor input
12	ARF	O	RF signal output
13	C. SBDO	I	Dropout detection capacitor input
14	RF DET	O	RF detection signal ("L": detecting)
15	BDO	O	Dropout detection output
16	V _{CC}	I	Power supply terminal
17	SDO	O	Dropout detection pulse output
18	VAD+	O	Power supply terminal for A/D converter (+)
19	VREF	O	Reference voltage output
20	VAD-	O	Power supply terminal for A/D converter (-)
21	OFTR	O	Off track detection ("H": det.)

Pin No.	Mark	I/O Division	Function
22	PLAY	I	Play signal ("H": ON, "L": OFF)
23	WVEL	I	Double velocity ("H": double, "L": single)
24	TES	I	Tracking error shunt ("H": shunt, "L": output)
25	PTO	O	Potential amp output
26	PTI	I	Potential amp input
27	PBO	O	Potential buffer output
28	POT	I	Potential buffer input
29	CROSS	O	Tracking error zero cross output
30	TE	O	Tracking error signal
31	TE BAL	I	Oscillation det. signal
32	TBAL	I	Tracking balance adj. input
33	VDET	O	Oscillation det. signal ("H": det.)
34	FE	O	Focusing error signal
35	FBL 2	I	Focusing balance 2
36	FBL 1	I	Focusing balance 1
37	V _{CC}	I	Power supply terminal
38	GND	—	GND terminal
39	PDBD	I	Photo detector Bch input with delay
40	PDA	I	Photo detector Ach input without delay
41	PDB	I	Photo detector Ach input with delay
42	PDAD	I	Photo detector Bch input without delay

• IC102 (MN6650A): Digital servo processor

Pin No.	Mark	I/O Division	Function
1	TES	O	Tracking error shunt signal ("H": shunt)
2	PLAY	O	Play signal ("H": play)
3	/RFDET	I	RF det. signal ("L": det.)
4	DO	I	Dropout signal ("H": dropout)
5	OFT	I	Off track signal ("H": off track)
6	ARF	I	RF signal input
7	WVEL	O	Double velocity status signal ("H": double)
8	PBO	I	Potensio buffer signal (analog input)
9	TE	I	Tracking error signal (analog input)
10	FE	I	Focus error signal (analog input)
11	VR2	I	Reference voltage for A/D (Low)
12	VR1	I	Reference voltage for A/D (High)
13	LDON	O	Laser power control ("H": ON)
14	V _{SS}	—	GND terminal
15	AV _{SS}	—	GND terminal
16	AV _{DD}	I	Power supply terminal
17	V _{DD}	I	Power supply terminal
18	TRV	O	Traverse servo control output
19	TVD	O	Traverse drive signal output
20	FOD	O	Focus drive signal output
21	TRD	O	Tracking drive signal output

Pin No.	Mark	I/O Division	Function
22	KICK	O	Kick pulse output
23	/TEST	I	Test terminal
24	V _{SS}	—	GND terminal
25	CLVS	I	Spindle servo phase synchro signal ("H": CLV, "L": Rough servo)
26	/TRON	O	Tracking servo ON signal ("L": ON)
27	MDATA	I	Command data signal
28	MCLK	I	Command clock signal
29	MLD	I	Command load signal ("L": LOAD)
30	SENSE	O	Sense signal
31	/FLOCK	O	Optical servo condition (focus) output
32	/TLOCK	O	Optical servo condition (tracking) output
33	/RST	I	Reset signal ("L": reset)
34	XI	I	Clock input (f=16.9344 MHz)
35 38	T0 T3	O	Test terminal (Ordinary: open)
39 41	T4 T6	I	Test terminal (Ordinary: L)
42	VDET	I	Oscillation det. signal ("H": det.)
43	TBAL	O	Tracking balance adj. output
44	TRCRS	I	Track cross signal input

• IC301 (MN6626): Digital signal processor

Pin No.	Mark	I/O Division	Function
1	AVSS	—	GND terminal
2	IREF	I	Reference current input
3	ARF	I	RF signal input
4	DRF	I	DSL bias terminal (Not used, open)
5	DSLIF	I/O	DSL loop filter sterminal
6	PLLIF	I/O	PLL loop filter terminal
7	AVDD	I	Power supply terminal
8	RSEL	I	RF signal polarity setting terminal (Not used, connected to VDD)
9 16	TBUS7 TBUS0	O	Test terminal
17	FLAG	O	Flag terminal (Not used, open)
18	IPFLAG	O	Interpolation flag terminal (Not used, open)
19	FCLK	O	Crystal frame clock (Not used, open)
20	BYTCK	O	Byte clock (Not used, open)
21	WDCK	O	Word clock (Not used, open)
22	/RST	I	Reset terminal
23	TX	O	Digital audio signal (Not used, open)
24	LDG	O	Lch deglitch signal (Not used, open)
25	RDG	O	Rch deglitch signal (Not used, open)
26	SRDATA	O	Serial data output (MSB first)
27	SCK	O	Serial bit clock output
28	LRCK	O	L/R discriminating signal
29	XCK	O	Crystal OSC terminal (f=16.9344 MHz) (Not used, open)
30	PMCK	O	Frequency division clock signal (Not used, open) $(f = \frac{1}{192} \times CK = 88.2 \text{ kHz})$
31	CSEL	I	Test terminal (Connected to GND)
32	PSEL		
33	X1	I	Crystal OSC terminal (f=16.9344 MHz)
34	X2	O	Crystal OSC terminal (f=16.9344 MHz) (Not used, open)
35	VSS	—	GND terminal
36	SUBQ	O	Sub-code Q data
37	SQCK	I	Sub-code Q register clock

Pin No.	Mark	I/O Division	Function
38	/CLDCK	O	Sub-code frame clock (f=735kHz) (Not used, open)
39	BLKCK	O	Sub-code block clock (f=75Hz)
40	DEMPH	O	De-emphasis ON signal ("H": ON)
41	MEMP	I	Emphasis signal
42	MLD	I	Command load signal ("L": LOAD)
43	MCLK	I	Command clock signal
44	MDATA	I	Command data signal
45	D MUTE	I	Muting input ("H": MUTE)
46	SMCK	O	System clock (f=4.2336 MHz)
47	STAT	O	Status signal (CRC, CUE, CLVS, TTSTOP, FCLV, SQOK)
48	CRC	O	Sub-code CRC check terminal ("H": OK, "L" NG) (Not used, open)
49	SUBC	O	Sub-code serial output data (Not used, open)
50	SBCK	I	Sub-code serial output clock (Not used, open)
51	/TRON	I	Tracking servo ON signal ("L": ON)
52	CLVS	O	Turntable servo phase synchro signal ("H": CLV, "L": Rough servo)
53	PC	O	Turntable motor ON signal ("L": ON)
54	ECM	O	Turntable motor drive signal (Forced mode)
55	ECS	O	Turntable motor drive signal (Servo error signal)
56	VDD	I	Power supply terminal
57	/TEST	I	Test terminal (Normal: "H")
58	SSEL	I	"SUBQ" terminal mode select ("H": Q code buffer)
59	MSEL	I	"SMCK" terminal frequency select ("L": SMCK=4.2336 MHz)
60	RESY	O	Re-synchronizing signal of frame sync. (Not used, open)
61	DO	I	Drop-out detection signal ("H": Drop-out)
62	EFM	O	EFM signal (Not used, open)
63	PCK	O	PLL extract clock (f=4.3218 MHz) (Not used, open)
64	PDO	O	Phase comparated signal of EFM and PCK (Not used, open)

• IC103 (AN8377N): Tracking focus/Traverse coil drive

Pin No.	Mark	I/O Division	Function
1	PV _{CC}	I	Drive power supply
2	V _{CC}	I	Power supply terminal
3	TB	O	External transistor base driving output
4	VMON	O	Voltage output (connected to GND)
5	TVD1	I	Traverse error signal input
6	FD1	I	Focus error signal input
7	TD1	I	Tracking error signal input
8	VREF	I	Reference voltage input

Pin No.	Mark	I/O Division	Function
9	TD-	O	Non-inverting output of focus driver
10	TD+	O	Inverting output of focus driver
11	FD-	O	Non-inverting output of tracking driver
12	FD+	O	Inverting output of tracking driver
13	TVD-	O	Non-inverting output of traverse driver
14	TVD+	O	Inverting output of driver
15	$\overline{\text{RESET}}$	O	Reset signal output (Not used, open)
16	PC	I	PC input (connect to GND)

• IC801 (MN64761): Digital filter & D/A converter

Pin No.	Mark	I/O Division	Function
1	NC	—	Not connected
2	CSEL	I	Test terminal (Connected to power supply)
3	LRCLK	I	L/R discriminating signal
4	BCLK	I	Serial bit clock signal
5	SR DATA	I	Serial data signal
6	DV _{SS}	—	GND (digital) terminal
7	384FS	O	384 fs (16.9344 MHz) output
8	MDATA	I	Command data signal (Not used, connected to power supply)
9	MCLK	I	Command clock signal (Not used, connected to power supply)
10	MLD	I	Command load signal (Not used, connected to power supply)
11	RST	I	Reset terminal
12	TEST3	I	Test terminal (Connected to GND)
13	TP1	O	Test terminal
14	TP2		
15	TEST1	I	Test terminal (Connected to GND)
16	DV _{DD}	I	Power supply (digital) terminal
17	TEST2	I	Test terminal (Connected to GND)
18	BSEL	I	Not used, connected to GND
19	RSEL		
20	LSEL		

Pin No.	Mark	I/O Division	Function
21	A V _{DD1}	I	Power supply (analog) terminal
22	OUTL 2 (-)	O	Lch (-) audio signal
23	OUTL 2 (+)	O	Lch (+) audio signal
24	OUTL 1 (-)	O	Lch (-) audio signal
25	OUTL 1 (+)	O	Lch (+) audio signal
26	A V _{SS1}	—	GND (analog) terminal
27	NC	—	Not connected
28	A V _{SS2}	—	GND (analog) terminal
29	OUTR 1 (+)	O	Rch (+) audio signal
30	OUTR 1 (-)	O	Rch (-) audio signal
31	OUTR 2 (+)	O	Rch (+) audio signal
32	OUTR 2 (-)	O	Rch (-) audio signal
33	A V _{DD2}	I	Power supply (analog) terminal
34	D V _{DD1}	I	Power supply (digital) terminal
35	D V _{SS1}	—	GND (digital) terminal
36	X2	O	Crystal OSC terminal (F=33.8688MHz)
37	X1	I	
38	D V _{SS2}	—	GND (digital) terminal
39	NSUB	I	Sub-strate terminal (Not used, connected to power supply)
40	D V _{DD2}	I	Power supply (digital) terminal
41	NC	—	Not connected
42	ZFLGB	O	Zero input detector terminal

• IC601 (MND1617RJAA2): System control & FL drive

Pin No.	Mark	I/O Division	Function
1	VDD	I	Power supply terminal
2	OSC2	O	Crystal OSC terminal (F: 4.2336MHz)
3	OSC1	I	
4	V _{SS}	—	GND terminal
5	XI	—	Not used, connected to GND
6	XO	—	Not used, open
7	P47		
8	P46		
9 } 13	P45 } P41	I	Key return signal
14 } 18	P40 } P32	O	Key scan signal
19	P33	O	LED drive (PAUSE) terminal
20	P32	O	LED drive (PLAY) terminal
21	P31 (SENSE)	I	Sense signal
22	P30 (FLOCK)	I	Optical servo condition (focus) input
23	P27 (TLOCK)	I	Optical servo condition (tracking) input
24	P26 (RESET)	O	Reset signal ("L": reset)
25	P25 (DMUTE)	O	Muting signal ("H": MUTE)
26	P24 (STAT)	I	Status signal
27	P23 (EMPH)	O	Emphasis signal
28	P22 (REC. E)	I	Synchro rec control terminal
29	P21 (SINC. R)	O	
30	P20	—	Not used, connected to GND
31	IRQ1	I	Remote control terminal

Pin No.	Mark	I/O Division	Function
32	P14	—	Not used, connected to GND
33	P13 (OPEN)	O	Motor (OPEN) drive terminal
34	P12 (CLOSE)	O	Motor (CLOSE) drive terminal
35	P11 (OPEN SW)	I	Disc tray (OPEN) detect terminal
36	P10 (CLOSE SW)	I	Disc tray (CLOSE) detect terminal
37	/RST	I	Reset signal ("L": reset)
38	P05 (MCLK)	O	Command clock signal
39	P04 (MLD)	O	Command load signal ("L": load)
40	P03 (MDATA)	O	Command data signal
41	P02 (SQCK)	O	Sub-code Q register clock signal
42	P01 (SUBQ)	I	Sub-code Q data signal
43	P00 (BLKCK)	I	Sub-code block clock (F=75Hz) signal
44	P95 (MUTE)	O	Muting signal ("H": MUTE)
45	P94	O	Key scan signal
46	P93		
47 } 49	P92 } P90	I	Key return signal
50	GM	—	Not used, connected to GND
51	SYNC	—	Not used, open
52	V _{PP}	I	Power supply terminal
53	P70	O	LED drive (VIRTUAL BATTERY OPERATION) terminal
54	P71	—	Not used, open
55 } 68	DGT13 } DGT0	O	Digit signal of FL display
69 } 84	SEG0 } SEG15	O	Segment signal of FL display

BLOCK DIAGRAM

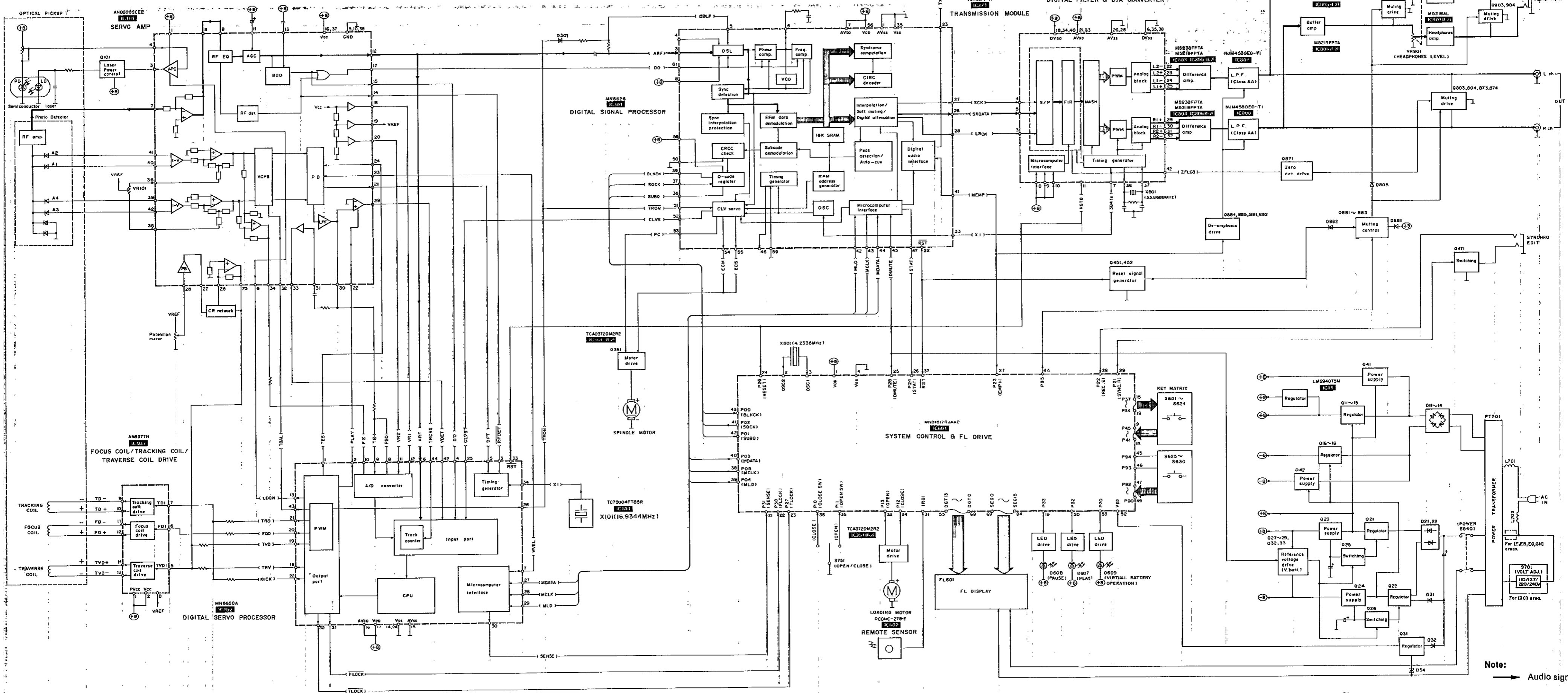

Note: → Audio signal

SCHEMATIC DIAGRAM (Parts list on pages 49~52.)

(This schematic diagram may be modified at any time with development of new technology.)

Note:

- S601~612: Numeric (0~10) switches.
[S601: 1, S602: 2, S603: 3, S604: 4, S605: 5, S606: 6, S607: 7, S608: 8, S609: 9, S610: 10, S611: >10, S612: 0]
- S613, 614: Skip (SKIP) switches.
[S613: ◀◀, S614: ▶▶]
- S615: Disc tray open/close (▲ OPEN/CLOSE) switch.
- S616: Stop (■ STOP) switch.
- S617: Pause (■ PAUSE) switch.
- S618: Play (▶ PLAY) switch.
- S619, 620: Search (◀◀ SEARCH ▶▶) switches.
[S619: ◀◀, S620: ▶▶]
- S621: Clear (CLEAR) switch.
- S622: Recall (RECALL) switch.
- S623: Program (PROGRAM) switch.
- S624: Display mode (DISPLAY MODE) switch.
- S625: Tape length (TAPE LENGTH) switch.
- S626: Tape side select (SIDE A/B) switch.
- S627: Peak search (PEAK SEARCH) switch.
- S628: Repeat (REPEAT) switch.
- S629: Random (RANDOM) switch.
- S630: Auto cue (AUTO CUE) switch.
- S640: Power (POWER) switch.
- S701: Voltage adj. switch in "240V" position.
[For (GC) area only.]
(110V ↔ 127V ↔ 220V ↔ 240V)

*The parenthesized are the values of voltage generated during playing (Test disc 1kHz, L+R, 0dB), others are voltage values in stop mode.

• Important safety notice:
Components identified by Δ mark have special characteristics important for safety. Furthermore, special parts which have purposes of fire-retardant (resistors), high-quality sound (capacitors), low-noise (resistors), etc. are used. When replacing any of components, be sure to use only manufacturer's specified parts shown in the parts list.

• The supply part number is described alone in the replacement parts list.

Part No.	Production Part No.	Supply Part No.
IC11	LM2940T5M	LM2940T5
IC602	RCDHC-278-E	RCDHC-278
IC803, 804	M5238FPTA	SVIM5238FP
IC805, 806	M5219FPTA	M5219FP
IC807, 808	NJM4580ED-T1	NJM4580ED

— / — : Positive voltage lines and negative voltage lines.
— : Digital/audio signal lines.

Caution!

- IC and LSI are sensitive to static electricity. Secondary trouble can be prevented by taking care during repair.
- Cover the parts boxes made of plastics with aluminum foil.
- Ground the soldering iron.
- Put a conductive mat on the work table.
- Do not touch the pins of IC or LSI with fingers directly.

• Terminal guide of IC's, transistors and diode

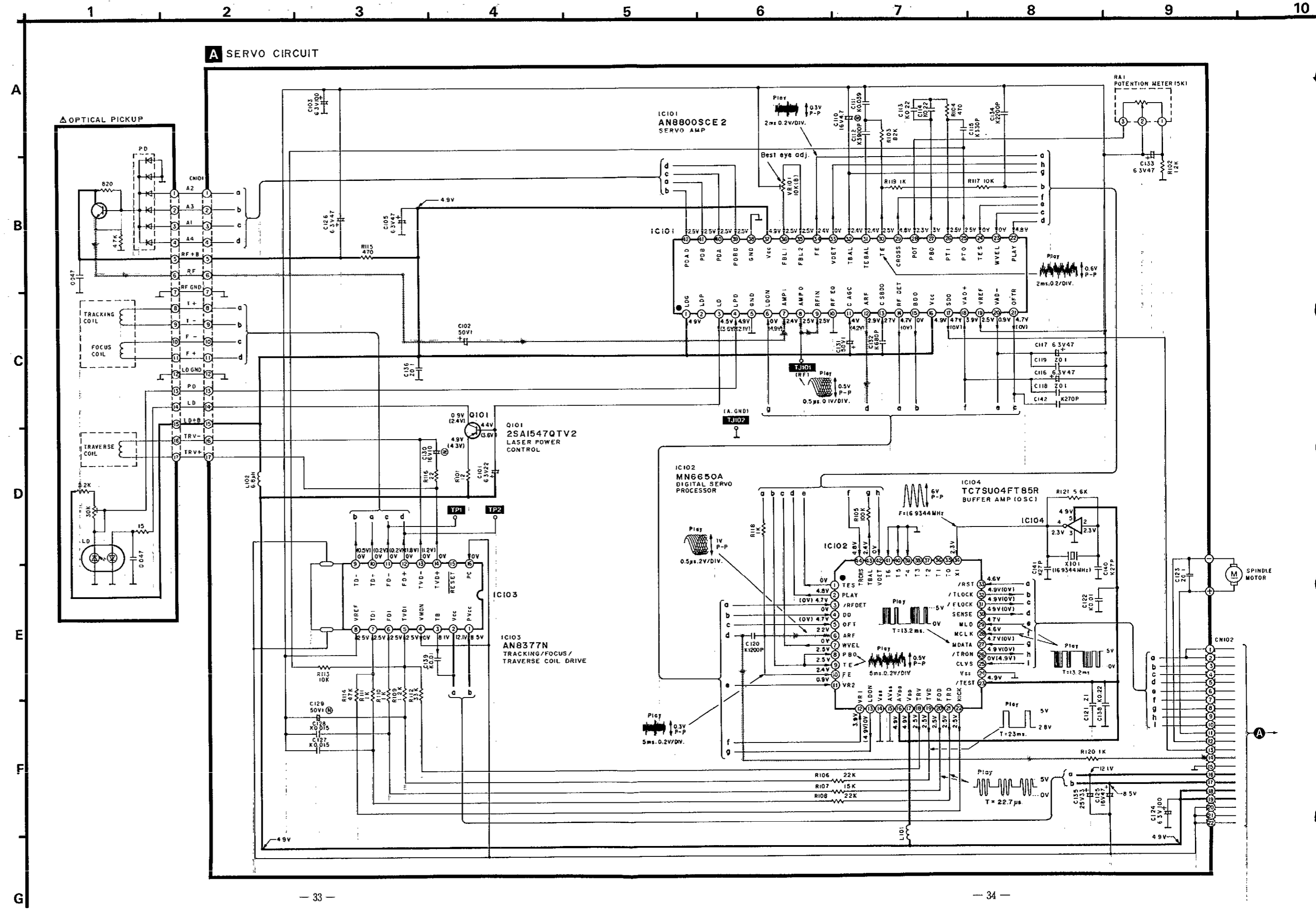

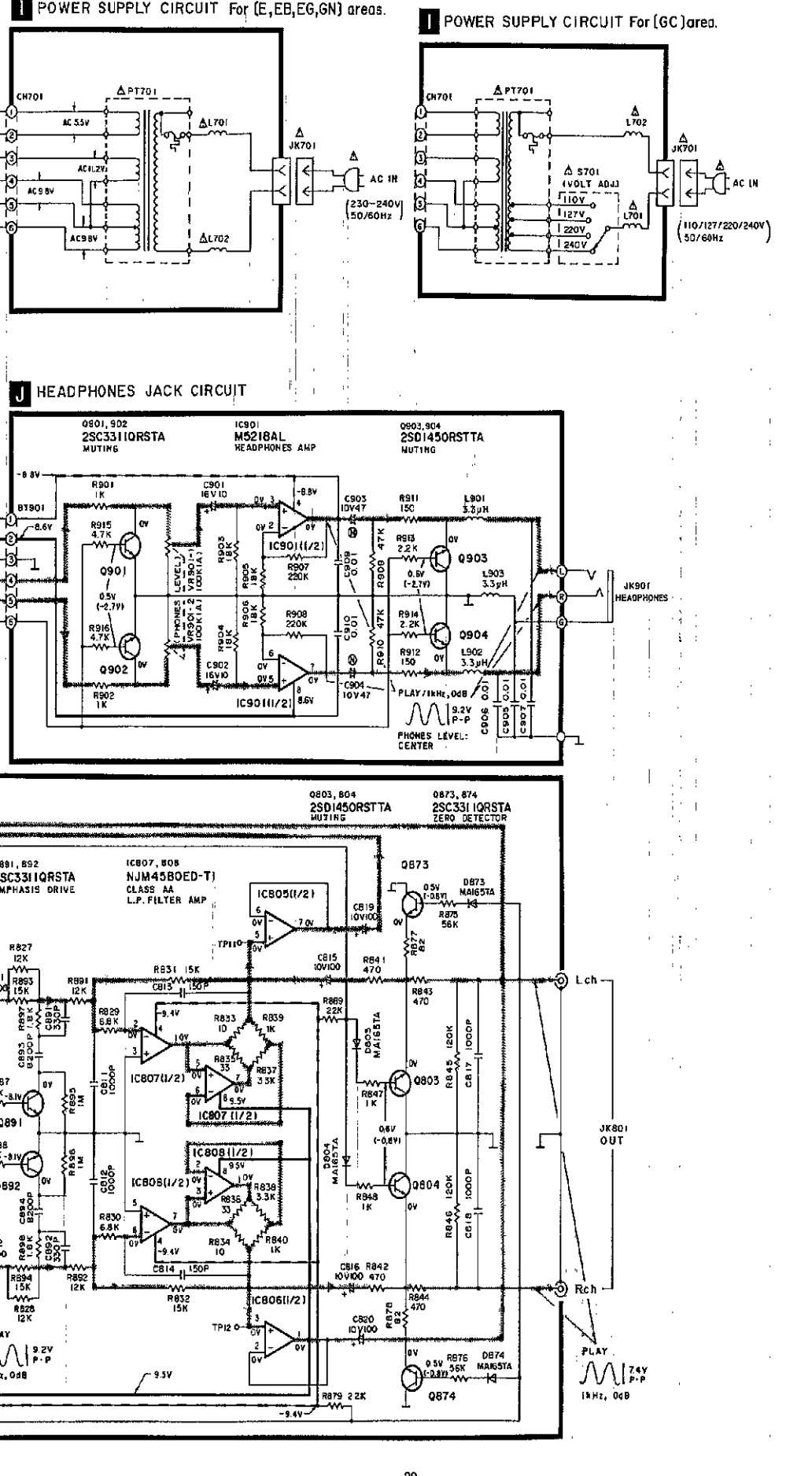
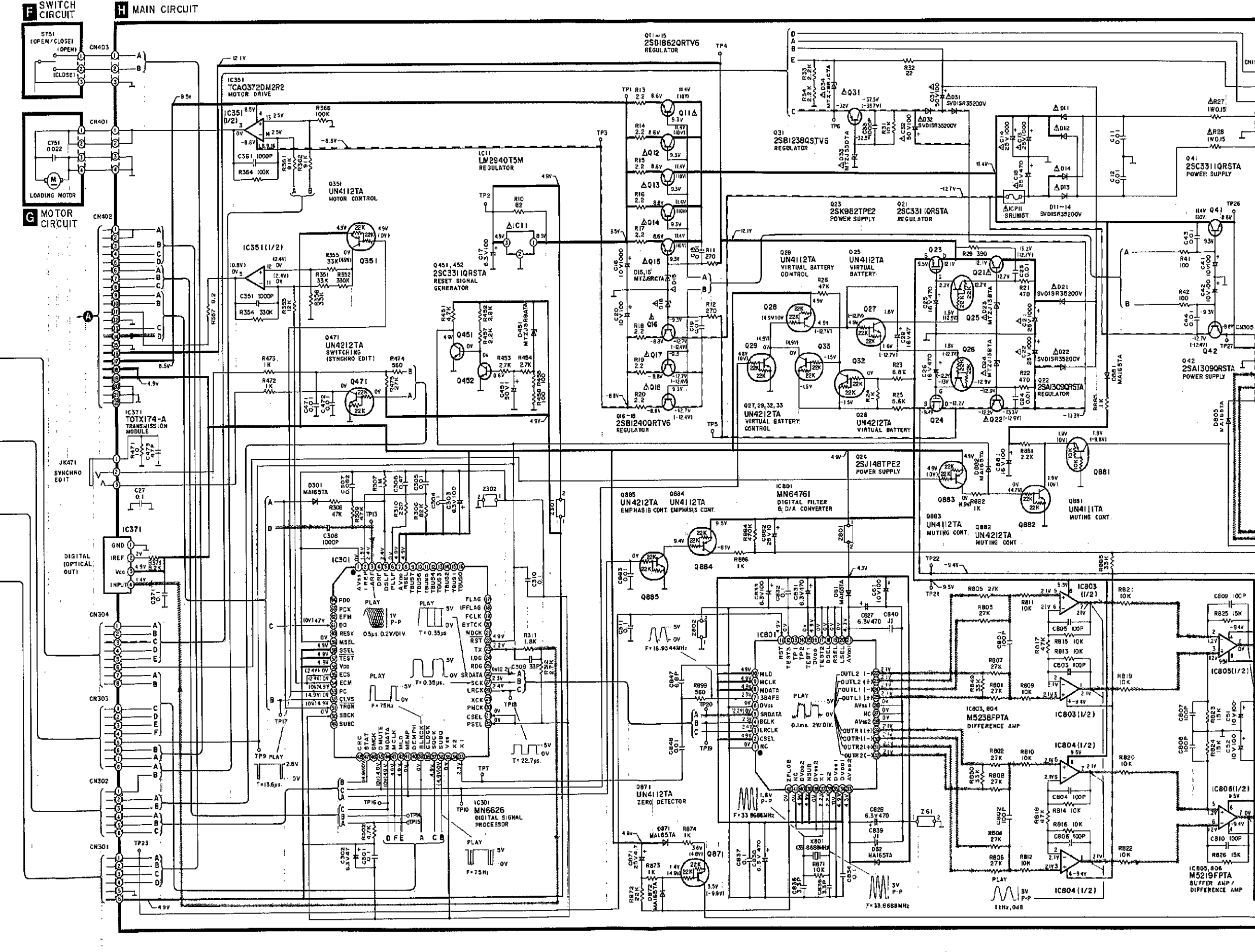
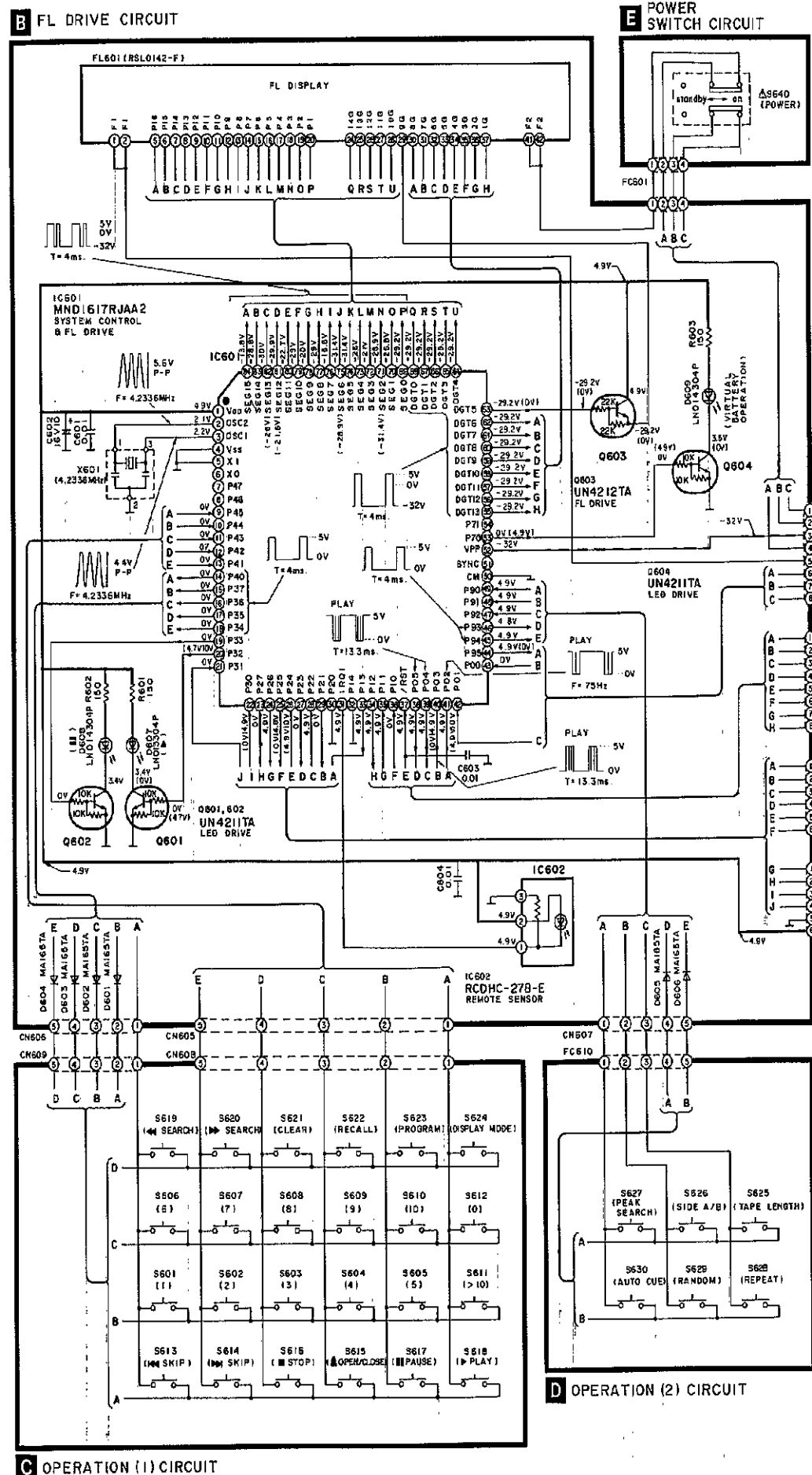

PRINTED CIRCUIT BOARDS

A SERVO P.C.B. (REP0766)

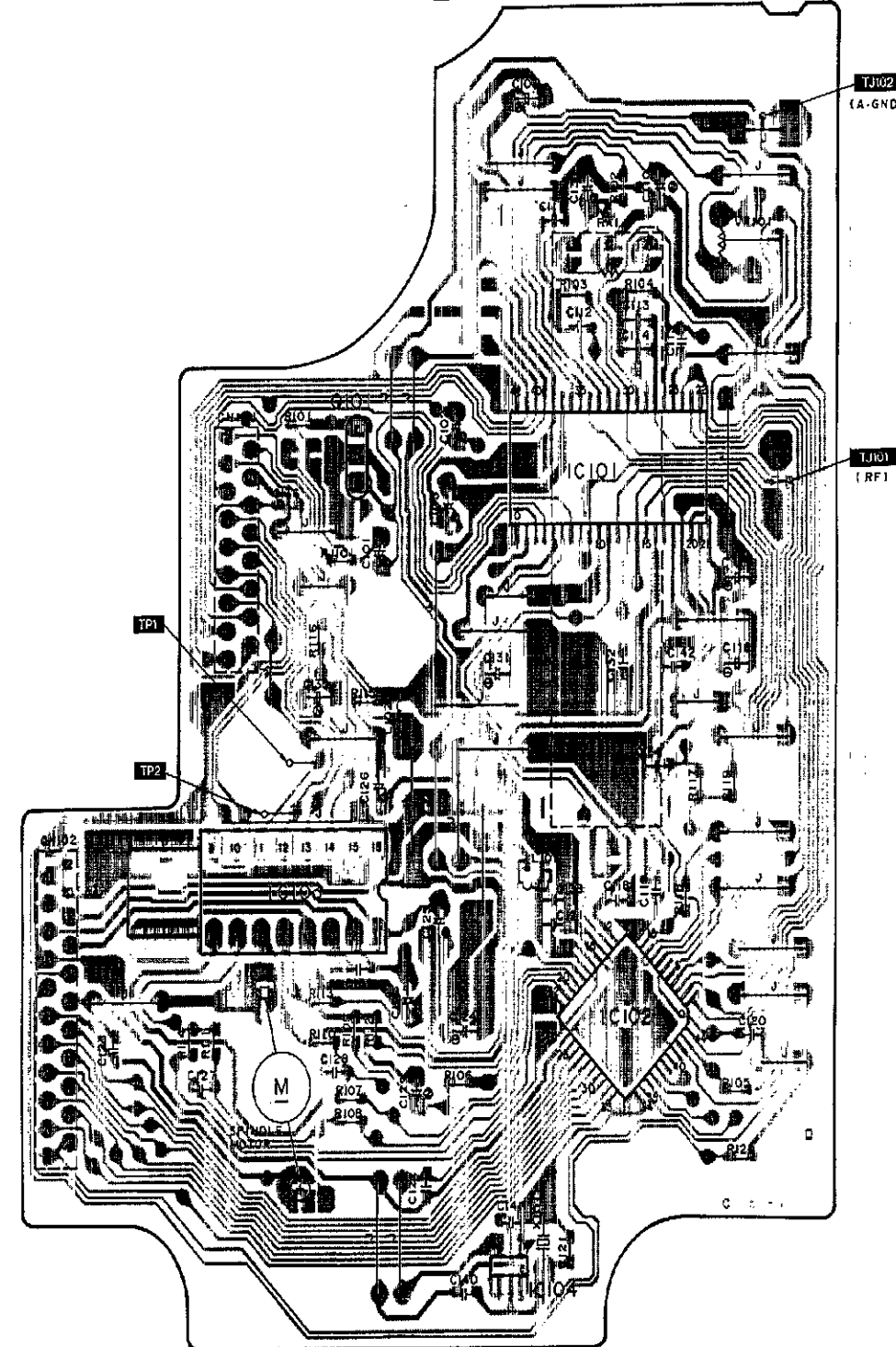

B FL DRIVE P.C.B. (REP1385A-S)

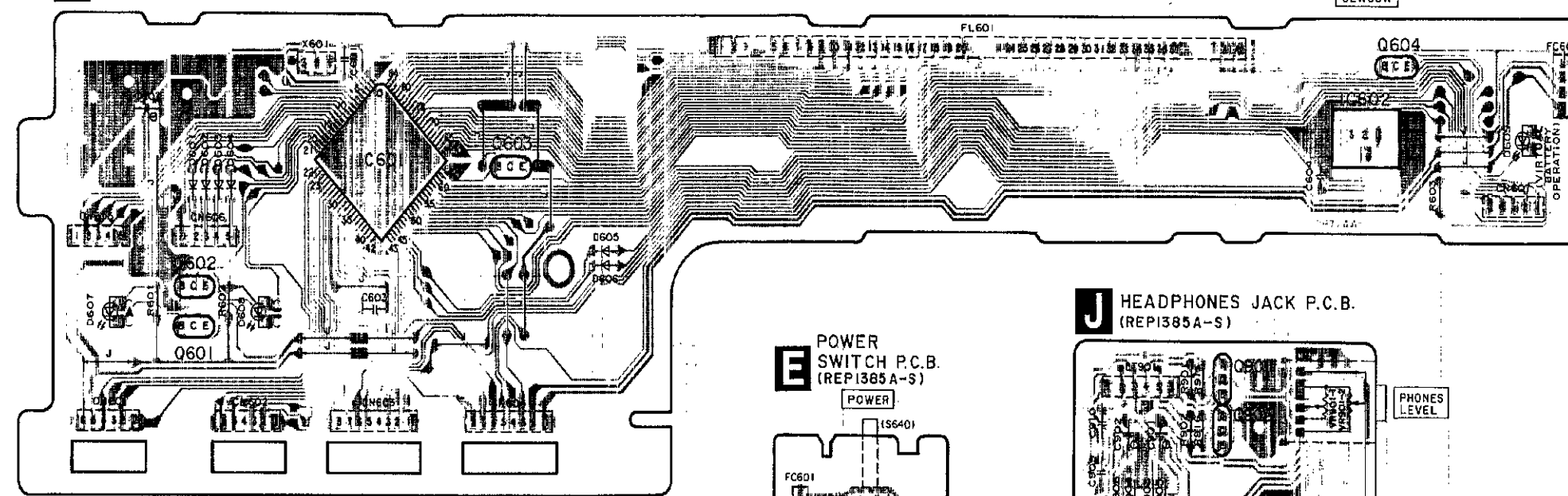

C OPERATION (1) P.C.B. (REP1385A-S)

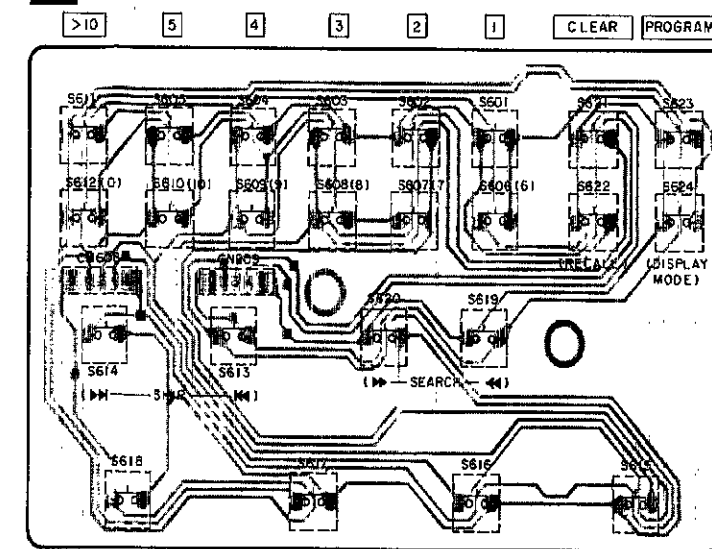

D OPERATION (2) P.C.B. (REP1385A-S)

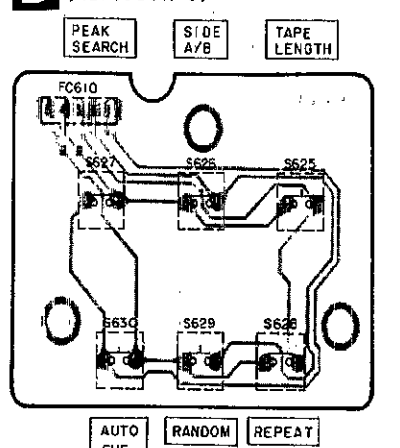

E POWER SWITCH P.C.B. (REP1385A-S)

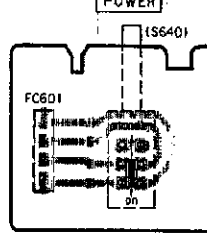

J HEADPHONES JACK P.C.B. (REP1385A-S)

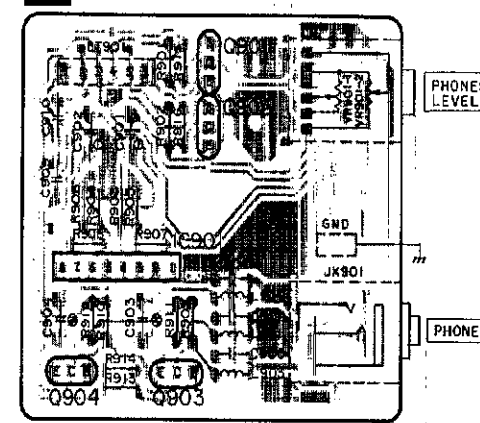

F SWITCH P.C.B. (REP0990)

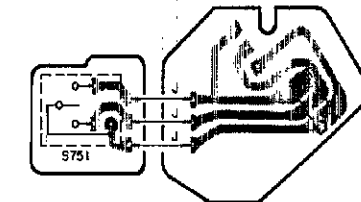

G MOTOR P.C.B. (REP0989)

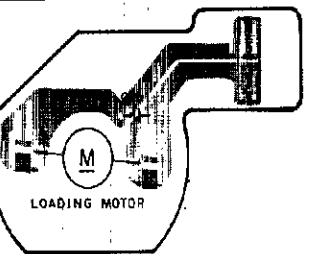

H MAIN P.C.B. (REP1384B-M)

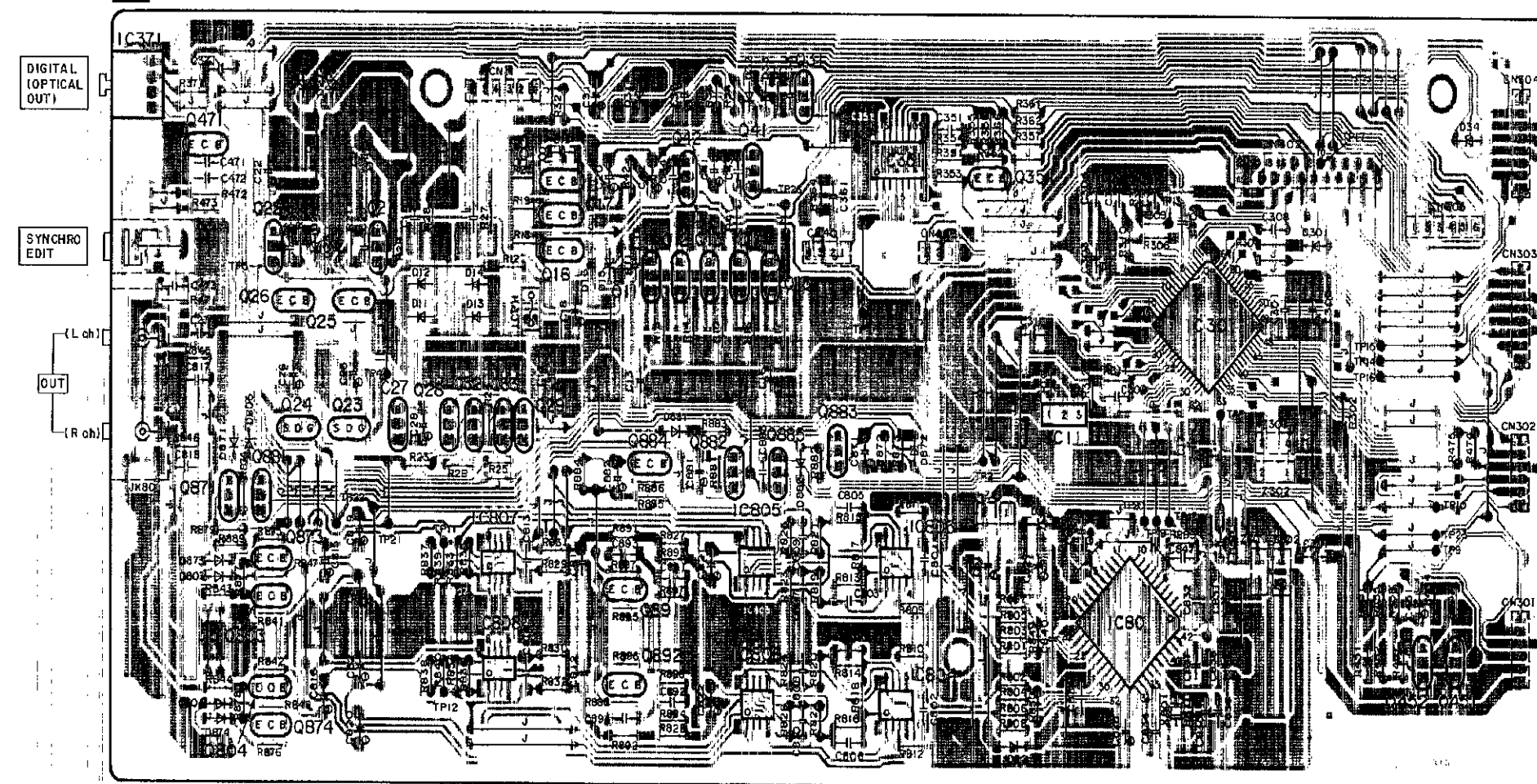

I POWER SUPPLY P.C.B. For (E,EB,EG,GN) areas. (REP1395C-P---(GN)
REP1395E-P---(E,EB,EG)

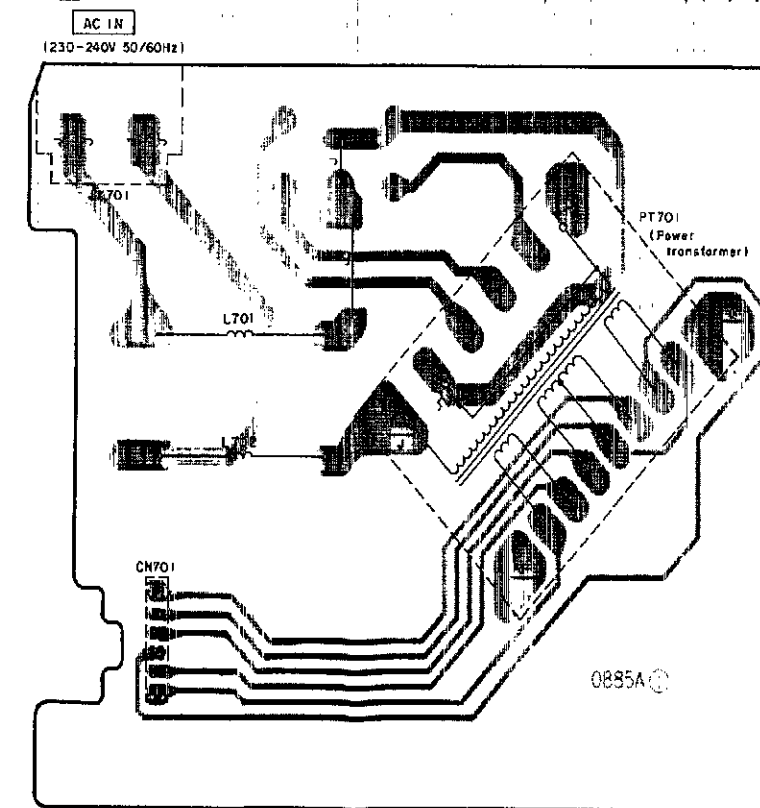

L POWER SUPPLY P.C.B. For (G) area. (REP1395B-P)

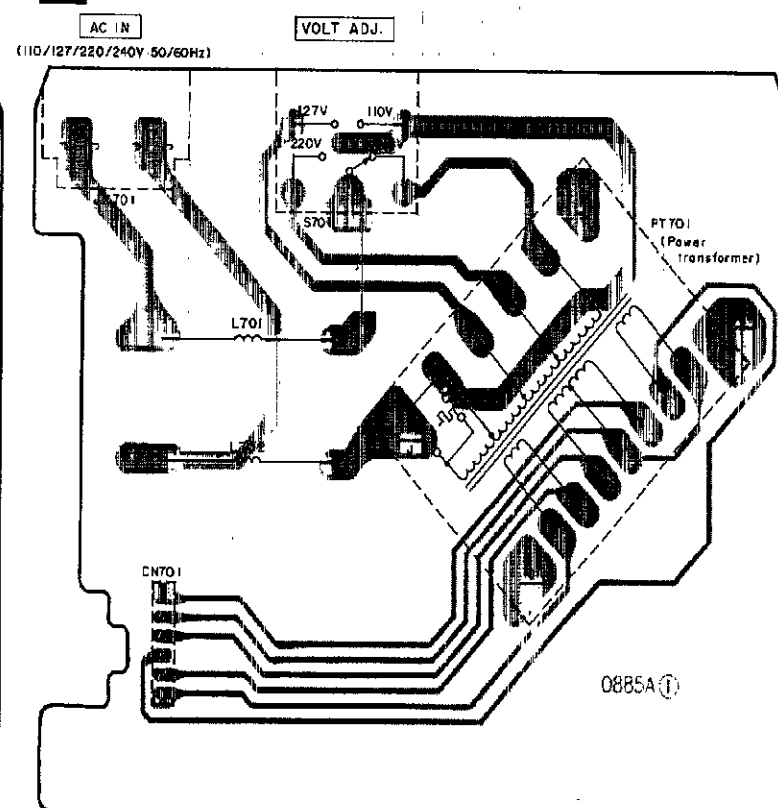

WIRING CONNECTION DIAGRAM

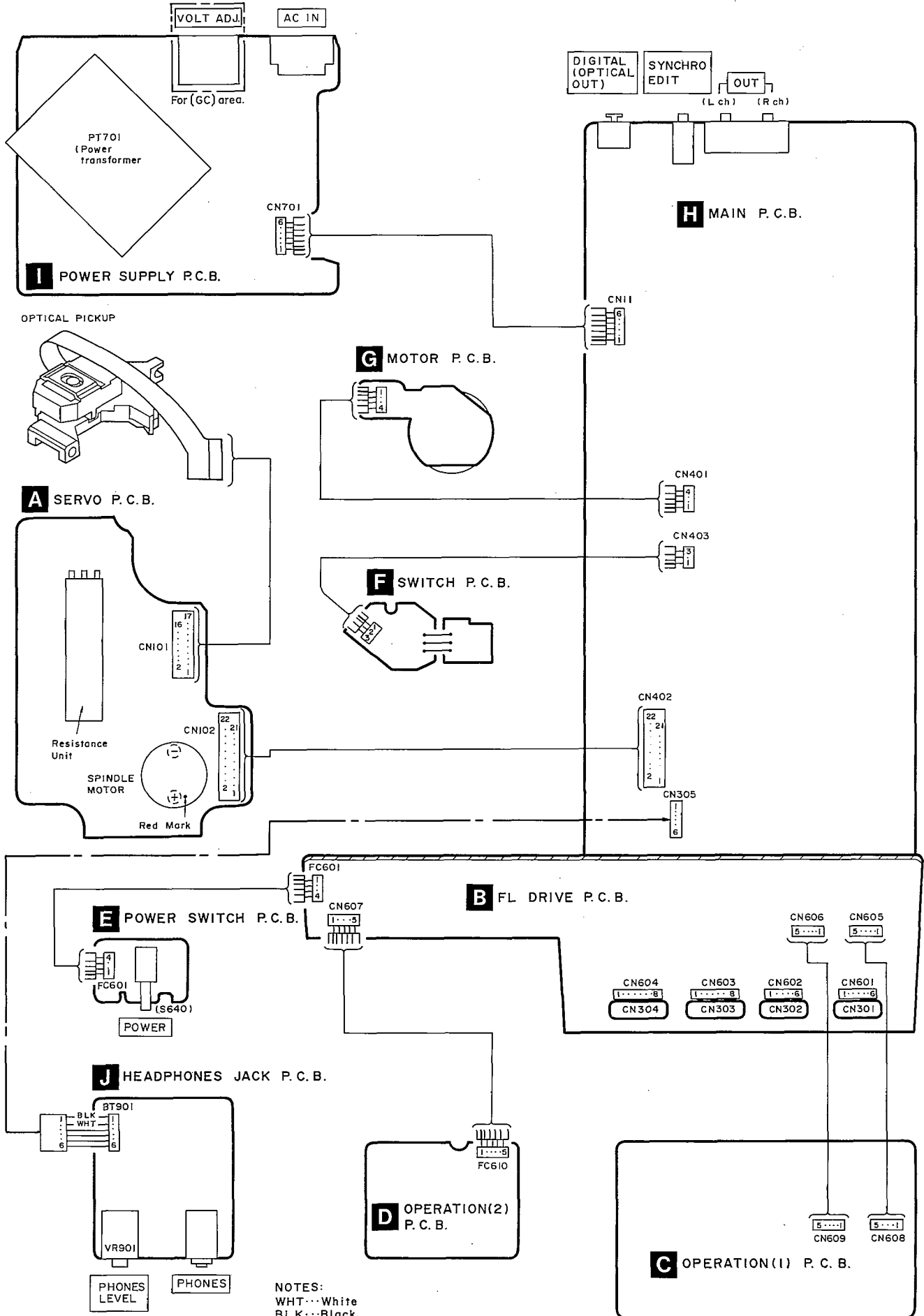

NOTES:
WHT...White
BLK...Black

REPLACEMENT PARTS LIST

Notes: *Important safety notice:

 Components identified by Δ mark have special characteristics important for safety.

Furthermore, special parts which have purposes of fire-retardant (resistors), high-quality sound (capacitors), low-noise (resistors), etc. are used.

When replacing any of components, be sure to use only manufacturer's specified parts shown in the parts list.

*The parenthesized indications in the Remarks columns specify the areas. (Refer to the cover page for area.)

Parts without these indications can be used for all areas.

*Remote Control Ass'y:

Supply period for three years from termination of production.

*Warning: This product uses a laser diode. Refer to caution statements on page 3.

*ACHTUNG: Die Lasereinheit nicht zerlegen.

Die Lasereinheit darf nur gegen eine vom Hersteller spezifizierte Einheit ausgetauscht werden.

Ref. No.	Part No.	Part Name & Description	Remarks	Ref. No.	Part No.	Part Name & Description	Remarks
		CABINET AND CHASSIS				PACKING MATERIAL	
1	RKMO210-1K	CABINET		P1	RPG1546	PACKING CASE	(E, EG, GC, GN)
2	SNE2129-1	SCREW		P1	RPG1418	PACKING CASE	(EB)
3	XTBS3+8JFZ1	SCREW		P2	RPN0654	CUSHION	(E, EG, GC, GN)
4	REZ0562	FLAT CABLE (6P)		P2	RPN0659	CUSHION	(EB)
5	RGK0508-1K	TRAY ORNAMENT		P3	RPQ0348	PAD	(E, EG, GC, GN)
6	RGK0510-T	BRACKET		P3	RPQ0281	PAD	(EB)
7	RFKHLPS840EK	REAR PANEL ASS'Y	(E)	P4	XZB60X65A01Z	PROTECTION BAG (UNIT)	
7	RFKHLPS840EB	REAR PANEL ASS'Y	(EB, GN)	P5	XZB22X20C03	PROTECTION BAG (CORD)	
7	RFKHLPS840EG	REAR PANEL ASS'Y	(EG)				
7	RFKHLPS840GC	REAR PANEL ASS'Y	(GC)			ACCESSORIES	
8	RKA0053-A	FOOT					
9	RKQ0089	P. C. B. SUPPORT		A1	RFKSLPS840EK	INSTRUCTION MANUAL ASS'Y	(E)
10	RKU0044A-K1	RUBBER BASE		A1	RQT1801-B	INSTRUCTION MANUAL	(EB)
11	RMA0615A	PUSH PLATE		A1	RFKSLPS840EG	INSTRUCTION MANUAL ASS'Y	(EG)
12	RMA0689	REINFORCING PLATE		A1	RFKSLPS840GC	INSTRUCTION MANUAL ASS'Y	(GC)
13	RMK0190	CHASSIS		A1	RQT1801-B	INSTRUCTION MANUAL	(GN)
14	RMCO186	EARTH PLATE		A2	RJA0019-2K	AC POWER SUPPLY CORD	(E, EG, GC) Δ
15	RMNO200	FL HOLDER		A2	VJA0733	AC POWER SUPPLY CORD	(EB) Δ
16	RFKGLPS840EK	FRONT PANEL ASS'Y		A2	SJA173	AC POWER SUPPLY CORD	(GN) Δ
16-1	RKWO246-K	FRONT ORNAMENT PLATE		A3	SJP2249-3	STEREO CONNECTION CABLE	
17	RGK0509-1K	ORNAMENT FRAME		A4	RQCB0169	SERVICENTER LIST	
18	RGU0030	POWER BUTTON		A5	RQA0013	WARRANTY CARD	(E, EB, EG)
19	RGU0814A-K	MAIN BUTTON		A5	RQX7433ZA	WARRANTY CARD	(GN)
20	RGU0816-K	SUB BUTTON		A6	RAK-SL512W	REMOTE CONTROL TRANSMITTER	
21	RGW0048	PHONES LEVEL KNOB		A6-1	RKK0020-K	BATTERY COVER	FOR R/C TRANSMITTER
22	RFKNLPS840PP	HEADPHONES HOLDER ASS'Y		A7	RQCA0235	INSTRUCTION MANUAL	
23	XTBS26+8J	SCREW		A8	RQLA0134	VOLTAGE CAUTION LABEL	(GC)
24	XTB3+14G	SCREW		A9	SJP5213-2	AC PLUG ADAPTOR	(GC) Δ
25	XTB3+20JFZ	SCREW					
26	XTB3+8F	SCREW					

EXPLODED VIEWS

• Cabinet and chassis parts

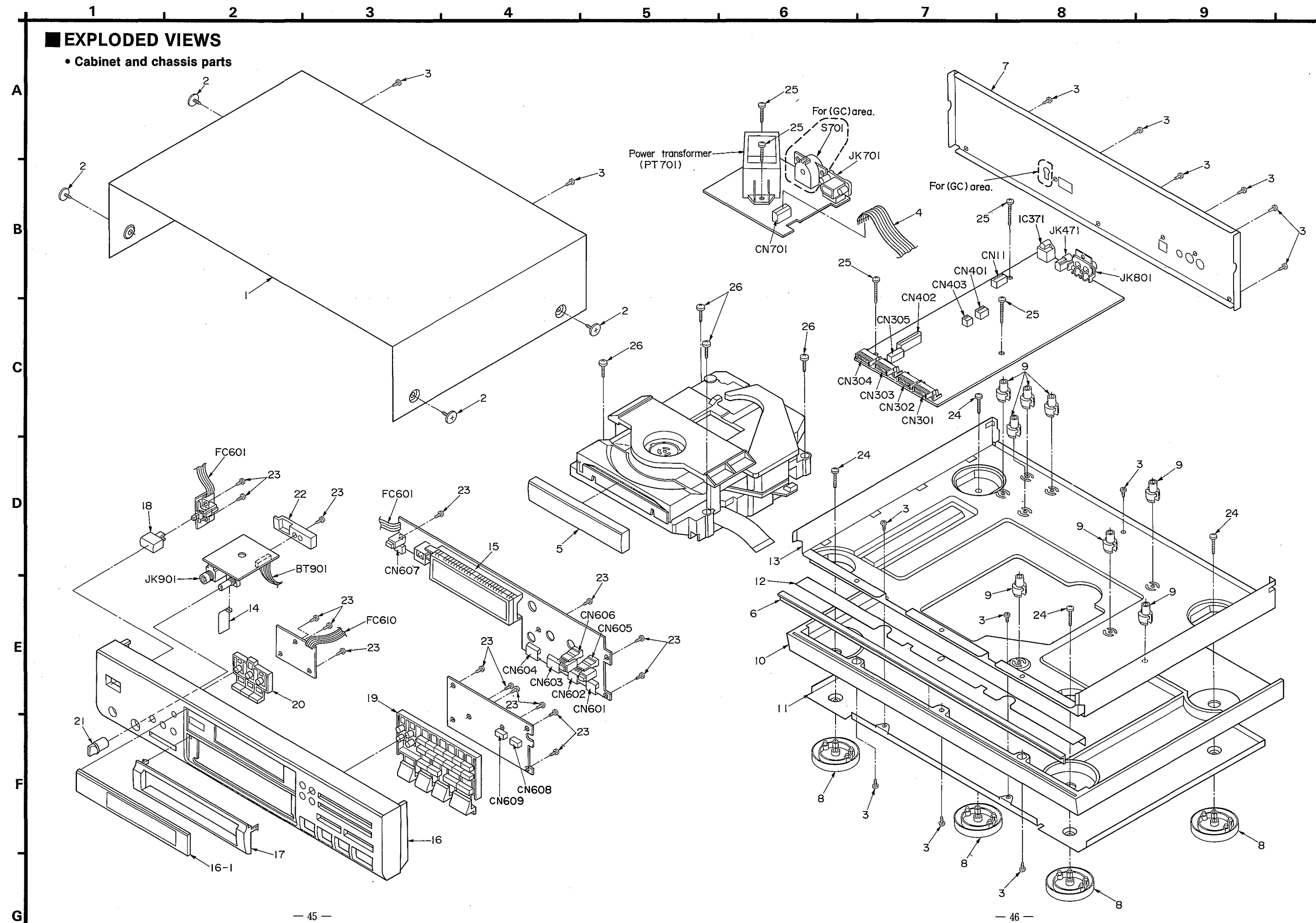

• Loading mechanism parts

Note: When changing loading mechanism parts, apply the specified grease to the areas marked "x" as shown in the drawing.

Ref. No.	Part No.
①	RZZ0L05
②	SZZ0L31

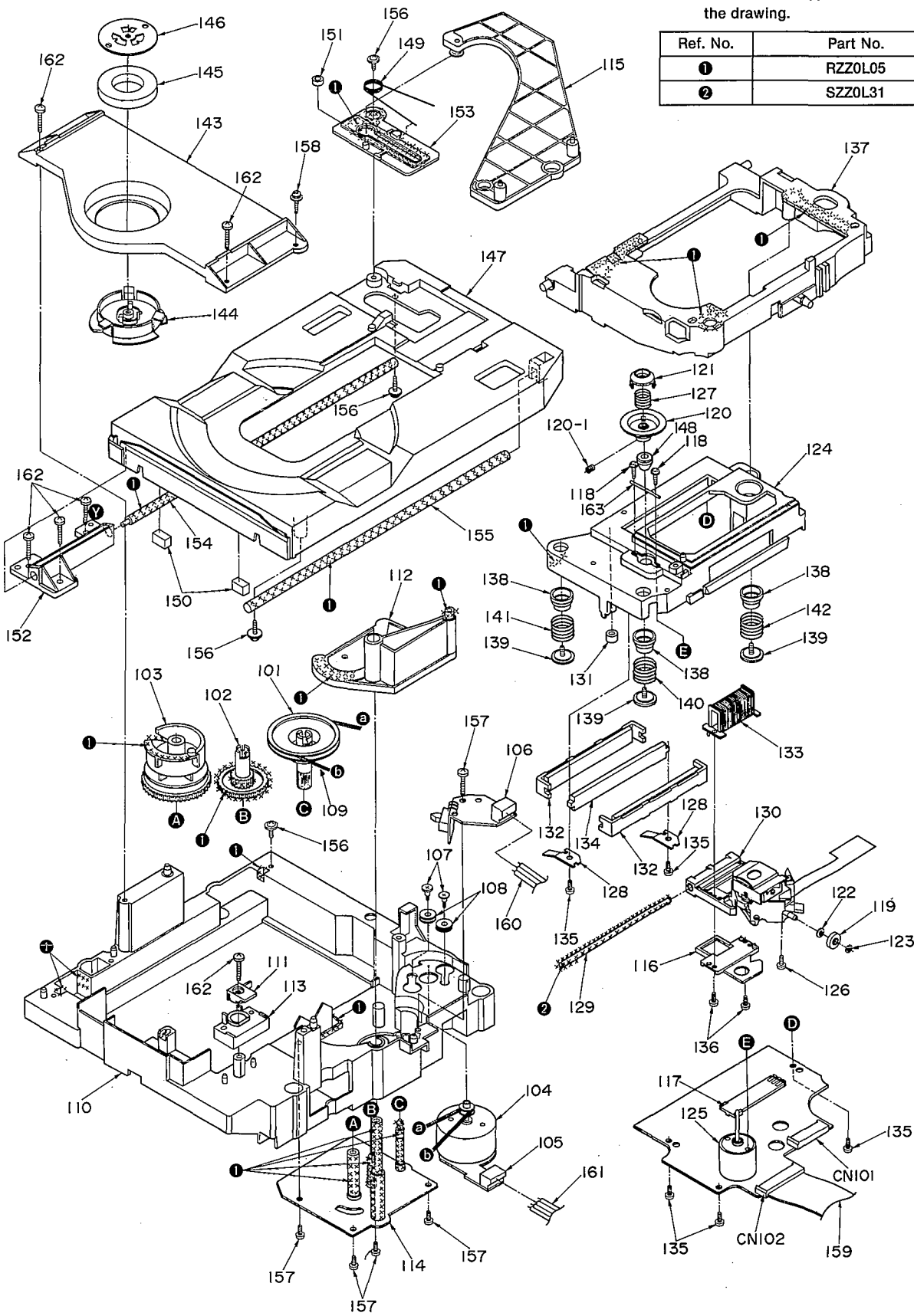

REPLACEMENT PARTS LIST

Notes: *Important safety notice:
 Components identified by Δ mark have special characteristics important for safety. Furthermore, special parts which have purposes of fire-retardant (resistors), high-quality sound (capacitors), low-noise (resistors), etc. are used. When replacing any of components, be sure to use only manufacturer's specified parts shown in the parts list.
 *The parenthesized indications in the Remarks columns specify the areas. (Refer to the cover page for area.)
 Parts without these indications can be used for all areas.
 *Warning: This product uses a laser diode. Refer to caution statements on page 3.
 *ACHTUNG: Die Lasereinheit nicht zerlegen.
 Die Lasereinheit darf nur gegen eine vom Hersteller spezifizierte Einheit ausgetauscht werden.

Ref. No.	Part No.	Part Name & Description	Remarks	Ref. No.	Part No.	Part Name & Description	Remarks
		LOADING MECHANISM		131	SHGD148	STOPPER RUBBER	
				132	RFKNLPC363P	YOKE (A) ASS'Y	
				133	SORD46-E	COIL ASS'Y	
101	RDG0154	PULLEY GEAR		134	SOYD22-1	YOKE (B)	
102	RDG0155	REDUCTION GEAR		135	XTB3+10G	SCREW	
103	RDK0015-1	DRIVE CAM		136	XTN2+5G	SCREW	
104	REMO026	LOADING MOTOR ASS'Y		137	RXQ0157	SUB BASE ASS'Y	
105	SJT30444-H	CONNECTOR (4P) (CN401)		138	SHGD153-1	FLOATING RUBBER	
106	SJT30344-H	CONNECTOR (3P) (CN403)		139	RHD30031	SCREW	
107	RHD26002	SCREW		140	SUSD136-1	FLOATING SPRING (A)	
108	RHG30322A	MOTOR CUSHION RUBBER		141	SUSD137-1	FLOATING SPRING (B)	
109	RMG0121	BELT		142	SUSD145-1	FLOATING SPRING (C)	
110	RMRO381-4	LOADING BASE		143	RFKNP2000EGC	CLAMP PLATE ASS'Y	(E)
111	RMRO384-3	SHAFT HOLDER (R)		143	RFKNP2000EBD	CLAMP PLATE ASS'Y	(EB, EG, GC, GN)
112	RMRO386-2	DRIVE PLATE		144	SIRD51-1	CLAMPER	
113	RMRO411-2	SHAFT HOLDER PLATE		145	SOMD4	MAGNET	
114	RXA0093	GEAR BASE ASS'Y		146	SOYD2	YOKE	
115	RXLO066	ROTARY LEVER		147	RFKNLPS840-K	DISC TRAY ASS'Y	
116	SHRD176-E	BRUSH HOLDER		148	RXQ0232	SIDE PRESSURE PULLEY	
117	SJED10	POTENTIOMETER HOLDER		149	REMO074	TRAY SPRING	
118	RMQ0299	SCREW		150	RMG0199	TRAY CUSHION RUBBER	
119	RMRO463	ROLLER		151	RMG0200	CUSHION RUBBER	
120	SDOD28-2E	TURNTABLE		152	RMRO383-1	SHAFT HOLDER (L)	
120-1	XXE26D5	SCREW		153	RMRO412-2	SLIDE PLATE	
121	SDOD29-2	RING		154	RMS0265-1	TRAY GUIDE SHAFT (L)	
122	SHWD33	WASHER		155	RMS0309-1	TRAY GUIDE SHAFT (R)	
123	SHWD34	WASHER		156	XTWS3+10Q	SCREW	
124	SISD22-7	TRAVERSE BASE		157	XTB3+10JFZ	SCREW	
125	SJGDRF310T-2	SPINDLE MOTOR		158	RHD30017-1	SCREW	
126	SNSD31	SCREW		159	REZ0328	FLAT CABLE (22P)	
127	SRQA010ND4	T. T. SPRING		160	REZ0338-1	FLAT CABLE (3P)	
128	SUWD112-2	SHAFT HOLDER		161	REZ0341	FLAT CABLE (4P)	
129	SUXD123-1	GUIDE SHAFT		162	XTB3+12JFZ	SCREW	
130	SOAD70A	OPTICAL PICKUP		163	RME0115	SIDE PRESSURE SPRING	

Ref. No.	Part No.	Part Name & Description	Remarks	Ref. No.	Part No.	Part Name & Description	Remarks
		INTEGRATED CIRCUIT(S)				DIODE(S)	
IC11	LM2940T5	IC, REGULATOR	△	D11-14	SVD1SR35200A	DIODE	△
IC101	AN8800SCE2	IC, SERVO AMP		D15, 16	MTZJ9R1CTA	DIODE	△
IC102	MN6650A	IC, DIGITAL SERVO PROCESSOR		D21, 22	SVD1SR35200A	DIODE	△
IC103	AN8377N	IC, COIL DRIVE		D23, 24	MTZJ13BTA	DIODE	△
IC104	TC7SU04FT85R	IC, INVERTER		D31, 32	SVD1SR35200A	DIODE	△
IC301	MN6626	IC, DIGITAL SIGNAL PROCESSOR		D33	MTZJ33DTA	DIODE	△
IC351	TCA0372DM2R2	IC, MOTOR DRIVE		D34	MTZJ9R1CTA	DIODE	△
IC371	TOTX174-A	IC, DIGITAL OUTPUT		D61, 62	MA165	DIODE	
IC601	MND1617RJAA2	IC, SYSTEM CONTROL&FL DRIVE		D301	MA165	DIODE	
IC602	RCDHC-278	IC, REMOTE SENSOR		D451	MTZJ3R9ATA	DIODE	
IC801	MN64761	IC, DIGITAL FILTER&D/A CONV.		D601-606	MA165	DIODE	
IC803, 804	SV1M5238FP	IC, DIFFERENCE AMP		D607	LN013304P	DIODE	
IC805, 806	M5219FP	IC, BUFFER AMP		D608, 609	LN014304P	DIODE	
IC807, 808	NJM4580ED	IC, CLASS AA L. P. F		D803-805	MA165	DIODE	
IC901	M5218AL	IC, HEADPHONES AMP		D871-874	MA165	DIODE	
		TRANSISTOR(S)		D881, 882	MA165	DIODE	
						IC PROTECTOR(S)	
Q11-15	2SD1862QRTV6	TRANSISTOR	△	ICP11	SRUN15	IC PROTECTOR	△
Q16-18	2SB1240-P	TRANSISTOR	△			VARIABLE RESISTOR(S)	
Q21	2SC3311A-Q	TRANSISTOR	△	VR101	EVND3AA00B14	V. R, BEST EYE ADJUSTMENT	
Q22	2SA1309A-R	TRANSISTOR	△	VR901	EVJCB0F02A15	V. R, HEADPHONES VOLUME	
Q23	2SK982TPE2	TRANSISTOR				COMPONENT COMBINATION(S)	
Q24	2SJ148TPE2	TRANSISTOR		Z61	BL02RN2R62T4	COMBINATION PART	
Q25	UN4112	TRANSISTOR		Z301, 302	BL02RN2R62T4	COMBINATION PART	
Q26, 27	UN4212TA	TRANSISTOR		Z801, 802	BL02RN2R62T4	COMBINATION PART	
Q28	UN4112	TRANSISTOR				COIL(S)	
Q29	UN4212TA	TRANSISTOR		L101	RLB0003	COIL	
Q31	2SB1238QSTV6	TRANSISTOR	△	L102	RELJHC6R8KTD	COIL	
Q32, 33	UN4212TA	TRANSISTOR		L701, 702	SLQX400-D	COIL	△
Q41	2SC3311A-Q	TRANSISTOR		L901-903	ELEXT3R3KA9	COIL	
Q42	2SA1309A-R	TRANSISTOR				TRANSFORMER(S)	
Q101	2SA1547QTV2	TRANSISTOR		PT701	RTP1K4B012	POWER TRANSFORMER	(E, EB, EG, GN) △
Q351	UN4112	TRANSISTOR		PT701	RTP1K4E020	POWER TRANSFORMER	(GC) △
Q451, 452	2SC3311A-Q	TRANSISTOR				OSCILLATOR(S)	
Q471	UN4212TA	TRANSISTOR		X101	RSXZ16M9M01T	OSCILLATOR (16. 934MHZ)	
Q601, 602	UN4211	TRANSISTOR		X601	RSXY4M23M01T	OSCILLATOR (4. 2336MHZ)	
Q603	UN4212TA	TRANSISTOR		X801	SVQ49U338S	OSCILLATOR (33. 868MHZ)	
Q604	UN4211	TRANSISTOR					
Q803, 804	2SD1450RTA	TRANSISTOR					
Q871	UN4112	TRANSISTOR					
Q873, 874	2SC3311A-Q	TRANSISTOR					
Q881	UN4111	TRANSISTOR					
Q882	UN4212TA	TRANSISTOR					
Q883, 884	UN4112	TRANSISTOR					
Q885	UN4212TA	TRANSISTOR					
Q891, 892	2SC3311A-Q	TRANSISTOR					
Q901, 902	2SC3311A-Q	TRANSISTOR					
Q903, 904	2SD1450RTA	TRANSISTOR					

Ref. No.	Part No.	Part Name & Description	Remarks	Ref. No.	Part No.	Part Name & Description	Remarks
				CN301, 302	RJU003K006M1	SOCKET (6P)	
		DISPLAY TUBE (S)		CN303, 304	RJU003K008M1	SOCKET (8P)	
				CN305	RJT029W06VT	CONNECTOR (6P)	
FL601	RSL0142-F	DISPLAY TUBE		CN401	RJS1A6604	SOCKET (4P)	
				CN402	RJS1A6822	SOCKET (22P)	
		SWITCH (ES)		CN403	RJS1A6603	SOCKET (3P)	
				CN601, 602	RJT003K006-1	CONNECTOR (6P)	
S601	EVQ21405R	SW, 1		CN603, 604	RJT003K008-1	CONNECTOR (8P)	
S602	EVQ21405R	SW, 2		CN605, 606	SJT30549BB1	CONNECTOR (5P)	
S603	EVQ21405R	SW, 3		CN607	SJT30544-H	CONNECTOR (5P)	
S604	EVQ21405R	SW, 4		CN608, 609	SJS50581BB	SOCKET (5P)	
S605	EVQ21405R	SW, 5		CN701	SJT30643-V	CONNECTOR (6P)	
S606	EVQ21405R	SW, 6				FLAT CABLE (S)	
S607	EVQ21405R	SW, 7					
S608	EVQ21405R	SW, 8		FC601	REZ0331	FLAT CABLE (4P)	
S609	EVQ21405R	SW, 9		FC610	REZ0563	FLAT CABLE (5P)	
S610	EVQ21405R	SW, 10					
S611	EVQ21405R	SW, >10				JACKS	
S612	EVQ21405R	SW, 0					
S613	EVQ21405R	SW, SKIP (R)		JK471	RJJ33T01	SYNCHRO EDIT	
S614	EVQ21405R	SW, SKIP (F)		JK701	SJS9236	AC INLET	(E, EB, EG, GC) Δ
S615	EVQ21405R	SW, OPEN/CLOSE		JK701	SJSD16	AC INLET	(GN) Δ
S616	EVQ21405R	SW, STOP		JK801	RJH3201A	OUTPUT	
S617	EVQ21405R	SW, PAUSE		JK901	QJA0455ZC-A	HEADPHONES	
S618	EVQ21405R	SW, PLAY				MAGNET RESISTOR ELEMENTS	
S619	EVQ21405R	SW, SEARCH (R)					
S620	EVQ21405R	SW, SEARCH (F)					
S621	EVQ21405R	SW, CLEAR					
S622	EVQ21405R	SW, RECALL		RA1	EWS7MOA00Q53	RESISTANCE UNIT	
S623	EVQ21405R	SW, PROGRAM					
S624	EVQ21405R	SW, DISPLAY MODE					
S625	EVQ21405R	SW, TAPE LENGTH					
S626	EVQ21405R	SW, SIDE A/B					
S627	EVQ21405R	SW, PEAK SEARCH					
S628	EVQ21405R	SW, REPEAT					
S629	EVQ21405R	SW, RANDOM					
S630	EVQ21405R	SW, AUTO CUE					
S640	SSH1230	SW, POWER	Δ				
S701	SSR187-1	SW, VOLTAGE ADJ.	(GC) Δ				
S751	RSH2B001	SW, OPEN/CLOSE DETECTOR					
		CONNECTOR ASS'Y (S)					
BT901	REX0476	CONNECTOR ASS'Y					
		CONNECTOR (S) AND SOCKET (S)					
CN11	RJS1A6606	SOCKET (6P)					
CN101	RJS1A6717-1Q	SOCKET (17P)					
CN102	RJS1A6722-1Q	SOCKET (22P)					

RESISTORS AND CAPACITORS

Notes : * Capacity values are in microfarads (uF) unless specified otherwise, P=Pico-farads (pF) F=Farads (F)
* Resistance values are in ohms, unless specified otherwise, 1K=1,000 (OHM), 1M=1,000k (OHM)

Ref. No.	Part No.	Values & Remarks	Ref. No.	Part No.	Values & Remarks	Ref. No.	Part No.	Values & Remarks
		RESISTORS	R364	ERDS2TJ104	1/4W 100K	R907, 908	ERDS2TJ224T	1/4W 220K
			R366	ERDS2TJ104	1/4W 100K	R909, 910	ERDS2TJ473	1/4W 47K
			R371	ERDS2TJ822	1/4W 8. 2K	R911, 912	ERDS2TJ151	1/4W 150
R10	ERDS2TJ820	1/4W 82	R451	ERDS2TJ472	1/4W 4. 7K	R913, 914	ERDS2TJ222	1/4W 2. 2K
R11, 12	ERDS2TJ271	1/4W 270	R452	ERDS2TJ222	1/4W 2. 2K	R915, 916	ERDS2TJ472	1/4W 4. 7K
R13-20	ERDS2TJ2R2T	1/4W 2. 2	R453, 454	ERDS2TJ272T	1/4W 2. 7K			CHIP JUMPER(S)
R21, 22	ERDS2TJ471	1/4W 470	R455	ERDS2TJ101	1/4W 100	RJ101	ERJ6GEYOR00V	CHIP JUMPER
R23	ERDAS3G682T	1/4W 6. 8K	R457	ERDS2TJ222	1/4W 2. 2K	TJ101, 102	ERD25VOR00T	CHIP JUMPER
R24	ERDAS3G102T	1/4W 1K	R458	ERDS2TJ101	1/4W 100			CAPACITORS
R25	ERDAS3G562T	1/4W 5. 6K	R471	ERDS2TJ100	1/4W 10			
R26	ERDS2TJ473	1/4W 47K	R472, 473	ERDS2TJ102	1/4W 1K			
R27, 28	ERQ16NKWR15E	1W 0. 15 Δ	R474	ERDS2TJ561	1/4W 560			
R29	ERDS2TJ391	1/4W 390	R475	ERDS2TJ273	1/4W 27K			
R31	ERDS2TJ103	1/4W 10K	R601-603	ERDS2TJ151	1/4W 150	C11, 12	ECBTIE103ZF	25V 0. 01U
R32	ERDS2TJ220T	1/4W 22	R801-808	ERDAS3G273T	1/4W 27K	C13, 14	ECA1EM102B	25V 1000U Δ
R33, 34	ERDS2TJ222	1/4W 2. 2K	R809-816	ERDAS3G103T	1/4W 10K	C15	ECBTIC103NS5	16V 0. 01U
R41, 42	ERDS2TJ101	1/4W 100	R817, 818	ERDAS3G473	1/4W 47K	C16	ECA1AM102B	10V 1000U
R101	ERJ6GEYJ120V	1/10W 12	R819-822	ERDAS3G103T	1/4W 10K	C17	ECEAOJKA101B	6. 3V 100U
R102	ERJ6GEYJ122V	1/10W 1. 2K	R823-826	ERDAS3G153T	1/4W 15K	C18	ECA1EM471B	25V 470U Δ
R103	ERJ6GEYJ823	1/10W 82K	R827, 828	ERDAS3G123T	1/4W 12K	C19	ECBTIC103NS5	16V 0. 01U
R104	ERJ6GEYJ471V	1/10W 470	R829, 830	ERDAS3G682T	1/4W 6. 8K	C20	ECEA1AKA101B	10V 100U
R105	ERJ6GEYJ104V	1/10W 100K	R831, 832	ERDAS3G153T	1/4W 15K	C21, 22	ECA1EPXS102E	25V 1000U Δ
R106	ERJ6GEYJ223V	1/10W 22K	R833, 834	ERDAS3G100T	1/4W 10	C23, 24	ECBTIC103NS5	16V 0. 01U
R107	ERJ6GEYJ153V	1/10W 15K	R835, 836	ERDAS3G330T	1/4W 33	C25, 26	ECA1CPXS471B	16V 470U
R108	ERJ6GEYJ223V	1/10W 22K	R837, 838	ERDAS3G332T	1/4W 3. 3K	C27	ECFRLE104ZF5	25V 0. 1U
R109	ERJ6GEYJ122V	1/10W 1. 2K	R839, 840	ERDAS3G102T	1/4W 1K	C28	ECEA1CKA470B	16V 47U
R110, 111	ERJ6GEYJ102V	1/10W 1K	R841-844	ERDAS3G471T	1/4W 470	C31, 32	ECEA1HU101	50V 100U Δ
R112	ERJ6GEYJ333V	1/10W 33K	R845, 846	ERDAS3G124T	1/4W 120K	C33	ECBT1H102KB5	50V 1000P
R113	ERJ6GEYJ103V	1/10W 10K	R847, 848	ERDS2TJ102	1/4W 1K	C41, 42	ECEA1AKA101B	10V 100U
R114	ERJ6GEYJ473V	1/10W 47K	R849, 850	ERDAS3G333	1/4W 33K	C43, 44	ECBTIC103NS5	16V 0. 01U
R115	ERJ6GEYJ471V	1/10W 470	R871	ERDS2TJ103	1/4W 10K	C51, 52	ECA1APXS101B	10V 100U
R116	ERJ6GEYJ220	1/10W 22	R872	ERDS2TJ223	1/4W 22K	C61	ECA1APXS101B	10V 100U
R117	ERJ6GEYJ103V	1/10W 10K	R873, 874	ERDS2TJ102	1/4W 1K	C101	ECEAOJKA220	6. 3V 22U
R118-120	ERJ6GEYJ102V	1/10W 1K	R875, 876	ERDS2TJ563	1/4W 56K	C102	ECEA1HKS010	50V 1U
R121	ERJ6GEYJ562V	1/10W 5. 6K	R877, 878	ERDS2TJ820	1/4W 82	C103	ECAOJKF101I	6. 3V 100U
R302	ERDS2TJ472	1/4W 4. 7K	R879	ERDS2TJ223	1/4W 22K	C105	ECEAOJKS470	6. 3V 47U
R306	ERDS2TJ823T	1/4W 82K	R881	ERDS2TJ222	1/4W 2. 2K	C110	ECEA1CSM4R7I	16V 4. 7U
R307	ERDS2TJ105T	1/4W 1M	R882, 883	ERDS2TJ102	1/4W 1K	C111	ECUV1C393KBN	16V 0. 039U
R308, 309	ERDS2TJ473	1/4W 47K	R884	ERDS2TJ474	1/4W 470K	C112	ECUV1H392KBN	50V 3900P
R310	ERDS2TJ221	1/4W 220	R885	ERDS2TJ333	1/4W 33K	C113, 114	ECUV1C224KBM	16V 0. 22U
R311	ERDS2TJ182	1/4W 1. 8K	R886-888	ERDS2TJ102	1/4W 1K	C115	ECUV1H331KBN	50V 330P
R312	ERDS2TJ272T	1/4W 2. 7K	R889	ERDS2TJ223	1/4W 22K	C116, 117	ECEAOJKA470I	6. 3V 47U
R351	ERDS2TJ333	1/4W 33K	R891, 892	ERDAS3G123T	1/4W 12K	C118, 119	ECUV1C104ZFN	16V 0. 1U
R352	ERDS2TJ334	1/4W 330K	R893, 894	ERDAS3G153T	1/4W 15K	C120	ECUV1H122KBN	50V 1200P
R353	ERDS2TJ123	1/4W 12K	R895, 896	ERDAS3G105T	1/4W 1M	C121	ECUV1C105ZFM	16V 1U
R354	ERDS2TJ334	1/4W 330K	R897, 898	ERDAS3G182	1/4W 1. 8K	C122	ECUV1E103KBN	25V 0. 01U
R355, 356	ERDS2TJ333	1/4W 33K	R899	ERDS2TJ561	1/4W 560	C123	ECUV1C104ZFN	16V 0. 1U
R357	ERDS2TJ8R2T	1/4W 8. 2	R901, 902	ERDS2TJ102	1/4W 1K	C124	ECAOJKF101I	6. 3V 100U
R361, 362	ERDS2TJ913	1/4W 91K	R903-906	ERDS2TJ183T	1/4W 18K	C125	ECEA1CKS470I	16V 47U

Ref. No.	Part No.	Values & Remarks	Ref. No.	Part No.	Values & Remarks	Ref. No.	Part No.	Values & Remarks
C126	ECEAOJKS470	6.3V 47U	C308	ECBT1H102KB5	50V 1000P	C831	ECAOJM471B	6.3V 470U
C127, 128	ECUV1E153KBN	25V 0.015U	C309	ECBT1H330J5	50V 33P	C832	ECBT1H104ZF5	50V 0.1U
C129	ECEA1HSNO10I	50V 1U	C310, 311	ECFR1E104ZF5	25V 0.1U	C833	ECEAOJKA101B	6.3V 100U
C130	ECEA1CSN100I	16V 10U	C351	ECBT1H102KB5	50V 1000P	C834	ECBT1H104ZF5	50V 0.1U
C131	ECEA1HKS010	50V 1U	C361	ECBT1H102KB5	50V 1000P	C835, 836	ECBT1H3R3K5	50V 3.3P
C132	ECUV1H681KBN	50V 680P	C371	ECFR1E104ZF5	25V 0.1U	C837	ECBT1H104ZF5	50V 0.1U
C133	ECEAOJKS470	6.3V 47U	C451	ECEA1HKA010B	50V 1U	C838	ECAOJM471B	6.3V 470U
C134	ECUV1H222KBN	50V 2200P	C471, 472	ECBT1C103NS5	16V 0.01U	C839, 840	ECQV1H105JM3	50V 1U
C135	ECEA1EKS330I	25V 33U	C473	ECBT1H470J5	50V 47P	C847	ECBT1H6R8K5	50V 6.8P
C136	ECUV1C104ZFN	16V 0.1U	C601	ECBT1C103NS5	16V 0.01U	C848	ECBT1C103NS5	16V 0.01U
C138	ECUV1C224KBM	16V 0.22U	C602	ECEA1CKS100L	16V 10U	C871	ECEA1EKA4R7B	25V 4.7U
C139	ECUV1E103KBN	25V 0.01U	C603, 604	ECBT1C103NS5	16V 0.01U	C881	ECEA1CKA101B	16V 100U
C140, 141	ECUV1H270KCN	50V 27P	C751	ECBT1E223ZF	25V 0.022U	C882	ECEA1EKA100B	25V 10U
C142	ECUV1H271KN	50V 270P	C801, 802	ECHR1H101JZ3	50V 100P	C883	ECBT1C103NS5	16V 0.01U
C301	ECFR1E104ZF5	25V 0.1U	C803-810	ECBT1H101KB5	50V 100P	C891, 892	ECHR1H331GZ3	50V 330P
C302	ECEAOJKA470B	6.3V 47U	C811, 812	ECHR1H102JZ3	50V 1000P	C893, 894	ECHR1H822GZ3	50V 8200P
C303	ECEAOJKA101B	6.3V 100U	C813, 814	ECHR1H151JZ3	50V 150P	C901, 902	ECEA1CKS100L	16V 10U
C304	ECFR1E104ZF5	25V 0.1U	C815, 816	ECA1APXS101B	10V 100P	C903, 904	ECEA1AN470S	10V 47U
C305	ECBT1C103NS5	16V 0.01U	C817, 818	ECHR1H102JZ3	50V 1000P	C905-907	ECBT1C103NS5	16V 0.01U
C306	ECQV1H474JM3	50V 0.47U	C819-822	ECA1APXS101B	10V 100U	C909, 910	ECBT1C103NS5	16V 0.01U
C307	ECQV1H823JM3	50V 0.082U	C827, 828	ECAOJPKS471B	6.3V 470U			

PACKAGING

