

Service Manual

Portable CD Player

SL-S118

COMPACT
disc
DIGITAL AUDIO

MASH*
multi-stage noise shaping

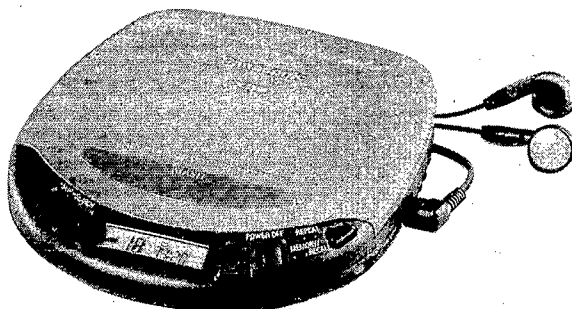

Colour (H) Gray Type
(A) Blue Type

Areas
E Europe.

* MASH is a trademark of NTT.

Please file and use this manual together with the service manual for Model No. SL-S120, Order No. AD9703050C8.

Note: • This simplified service manual is provided to indicate the main differences between the original model No. SL-S120(E) and the subsequent model No. SL-S118(E).

Traverse Deck: RAE0142Z Mechanism Series Specifications

Audio		Panasonic Alkaline dry cell batteries:(LR6, 2pcs.) : Approx. 10 h
No. of channels:	2 channels (left and right, stereo)	Rechargeable batteries (When rechargeable 3 hours.) : Approx. 3 h
Output voltage:	0.6 V(50 kohm) diameter 3.5 stereo mini jack	The play time may be less depending on the operating conditions.
Frequency response:	20 ~ 20,000 Hz (+0.5 dB, -1.5 dB)	
S/N:	more than 94 dB	
Wow and flutter:	Below measurable limit	General
DA converter:	1 bit, MASH*	Operation temperature range: 0-40 degree
Headphone output level:	max.9 mW+9 mW/16 ohm (variable)	Rechargeable temperature range: 5-40 degree
	stereo mini jack diameter 3.5	Power supply: DC 4.5 V
Digital filter:	8 times over sampling	Power consumption:
		AC adaptor; 5.5 W
Signal Format		Battery (DC 3V); 0.6 W
Correction system:	Technics New Super Decoding Algorithm	When recharging; 3.3 W
		Dimensions: 128(Wide)/28.0(High)/144(Depth)mm
Pickup		Weight: 220 g without batteries 265 g with batteries
Type:	One beam	
Light source:	Semiconductor laser	
Wavelength:	780 nm	
Lens:	Glass pressed lens	

Playing time

(When used in hold mode, at 25 degree temperature and on flat and stable surface.)

⚠ WARNING

This service information is designed for experienced repair technicians only and is not designed for use by the general public. It does not contain warnings or cautions to advise non-technical individuals of potential dangers in attempting to service a product. Products powered by electricity should be serviced or repaired only by experienced professional technicians. Any attempt to service or repair the product or products dealt with in this service information by anyone else could result in serious injury or death.

© 1997 Matsushita Electric Industrial Co., Ltd.
All rights reserved. Unauthorized copying and distribution is a violation of law.

Panasonic®

■ Schematic Diagram (See parts list on pages 8, 9.)

(This schematic diagram may be modified at any time with the development of new technology.)

Notes:

- S201: Laser ON/OFF switch in "OFF" position.
(It turns "ON" with disc holder closed.)
 - S202: Rest detector in "OFF" position.
(It turns "ON" when optical pickup comes to innermost periphery.)
 - S301: Memory/recall (MEMORY/RECALL) switch.
 - S302: Repeat (REPEAT) switch.
 - S303, 304: Skip/search (◀◀ -SKIP--SEARCH ▶▶) switches.
(S303: ◀◀ , S304: ▶▶)
 - S305: Stop/power off (■ POWER OFF) switch.
 - S306: Play/pause (▶ ||) switch.
 - S307: Play mode selector (MODE) in "RANDOM" position.
(RANDOM NORMAL RESUME)
 - S308: Hold (HOLD) switch in "ON" position.
 - S701: MODE (XBS ON/OFF) switch "ON" position.
- The voltage value and waveforms are the reference voltage of this measured by DC electronic voltmeter (high impedance) and oscilloscope on the basis of GND terminal (DC IN Jack). Accordingly, there may arise some errors in the voltage values and waveforms depending upon the internal impedance of the tester or measuring unit.
 - * The parenthesized is the voltage for test disc (1 kHz, L+R, 0 dB) in play mode, and the other, for no disc in stop mode.
 - * AC adaptor is used for power supply.
 - : Positive voltage lines.
 - : Audio signal lines.
 - Important safety notice:
Components identified by Δ mark have special characteristics important for safety. Furthermore, special parts which have purposes of fire-retardant (resistors), high-quality sound (capacitors), low-noise (resistors), etc. are used. When replacing any of components, be sure to use only manufacture's specified parts shown in the parts list.

Caution!

- IC and LSI are sensitive to static electricity. Secondary trouble can be prevented by taking care during repair.
- Cover the parts boxes made of plastics with aluminum foil.
 - Ground the soldering iron.
 - Put a conductive mat on the work table.
 - Do not touch the pins of IC or LSI with fingers directly.

■ Type Illustration of IC's, Transistors and Diodes

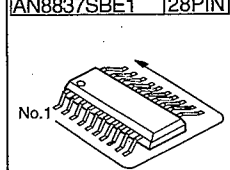
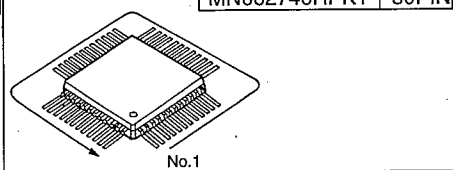
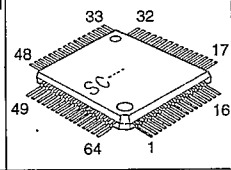
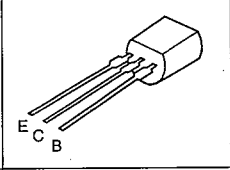
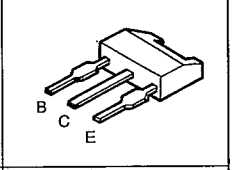
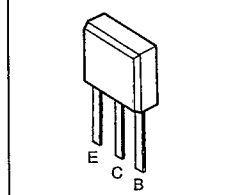
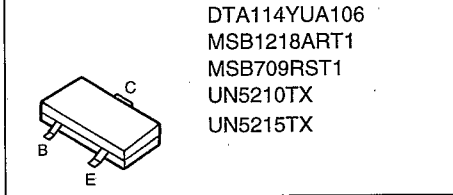
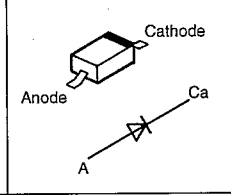
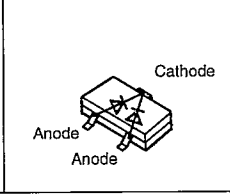
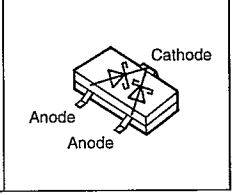
<table border="1"> <tr><td>NJU7082AMTE1</td><td>8PIN</td></tr> <tr><td>AN8837SBE1</td><td>28PIN</td></tr> </table> 	NJU7082AMTE1	8PIN	AN8837SBE1	28PIN	<table border="1"> <tr><td>BA6893KE2</td><td>44PIN</td></tr> <tr><td>MN662746RPK1</td><td>80PIN</td></tr> </table> 	BA6893KE2	44PIN	MN662746RPK1	80PIN	<p>SC440303CFU</p> 	<p>2SD1302STTA</p> 	<p>2SD2074HWRST</p> 
NJU7082AMTE1	8PIN											
AN8837SBE1	28PIN											
BA6893KE2	44PIN											
MN662746RPK1	80PIN											
<p>2SD1450STTA</p> 	<p>2SD1328RSTTX DTA114YUA106 MSB1218ART1 MSB709RST1 UN5210TX UN5215TX</p> 	<p>MA110TX</p> 	<p>M1MA141WKT1</p> 	<p>RB411DT146</p> 								

(P.C.Board: on page 7)

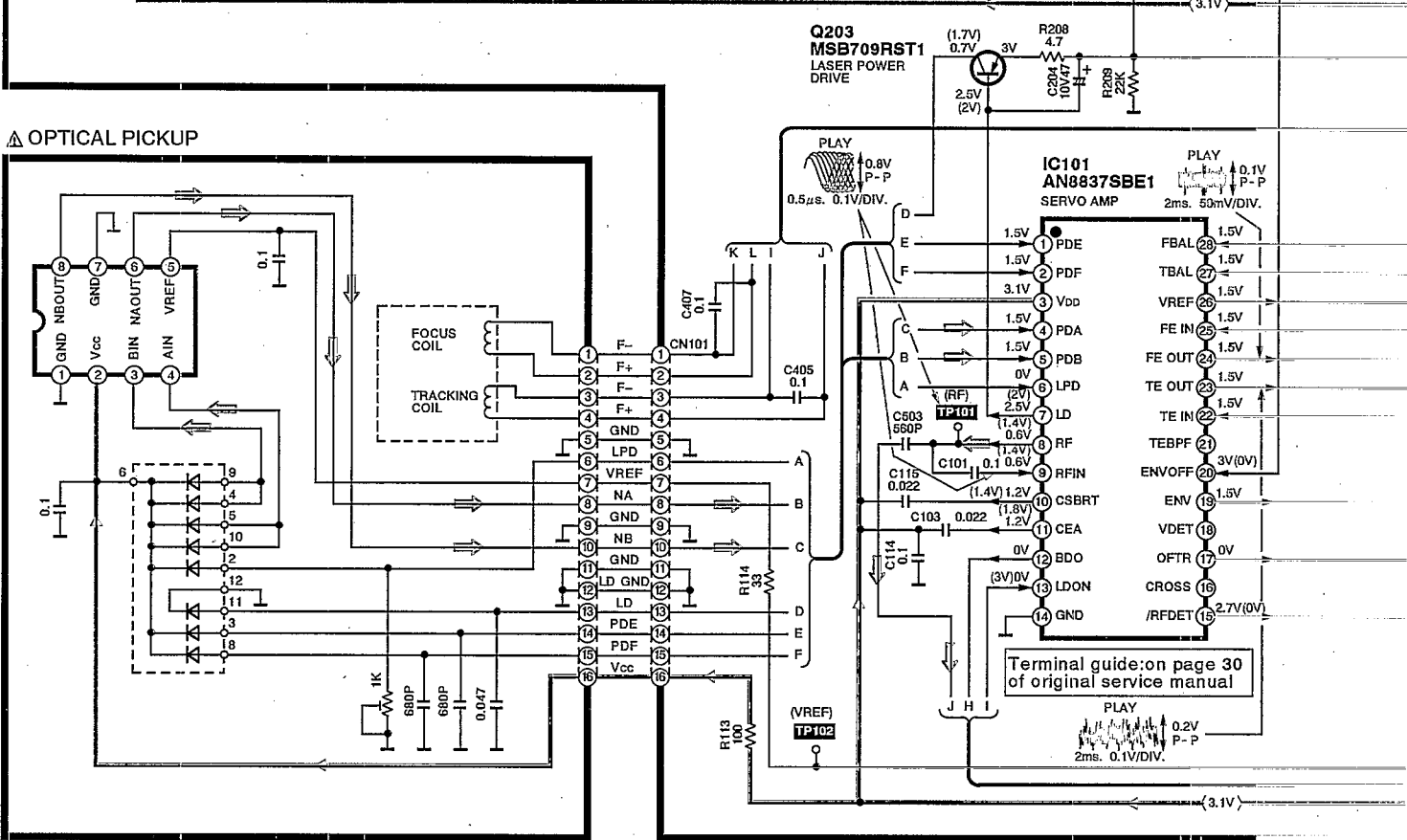
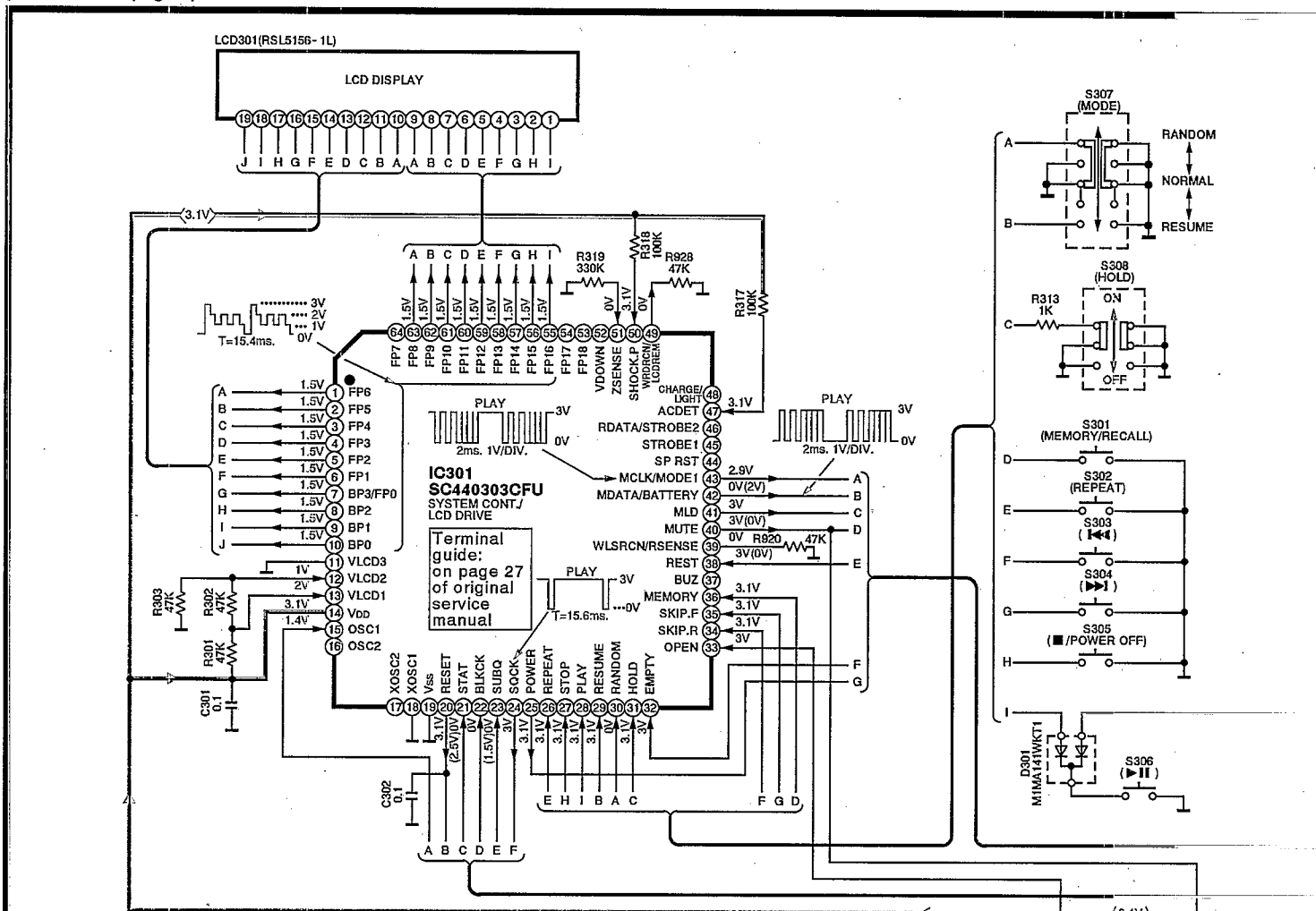

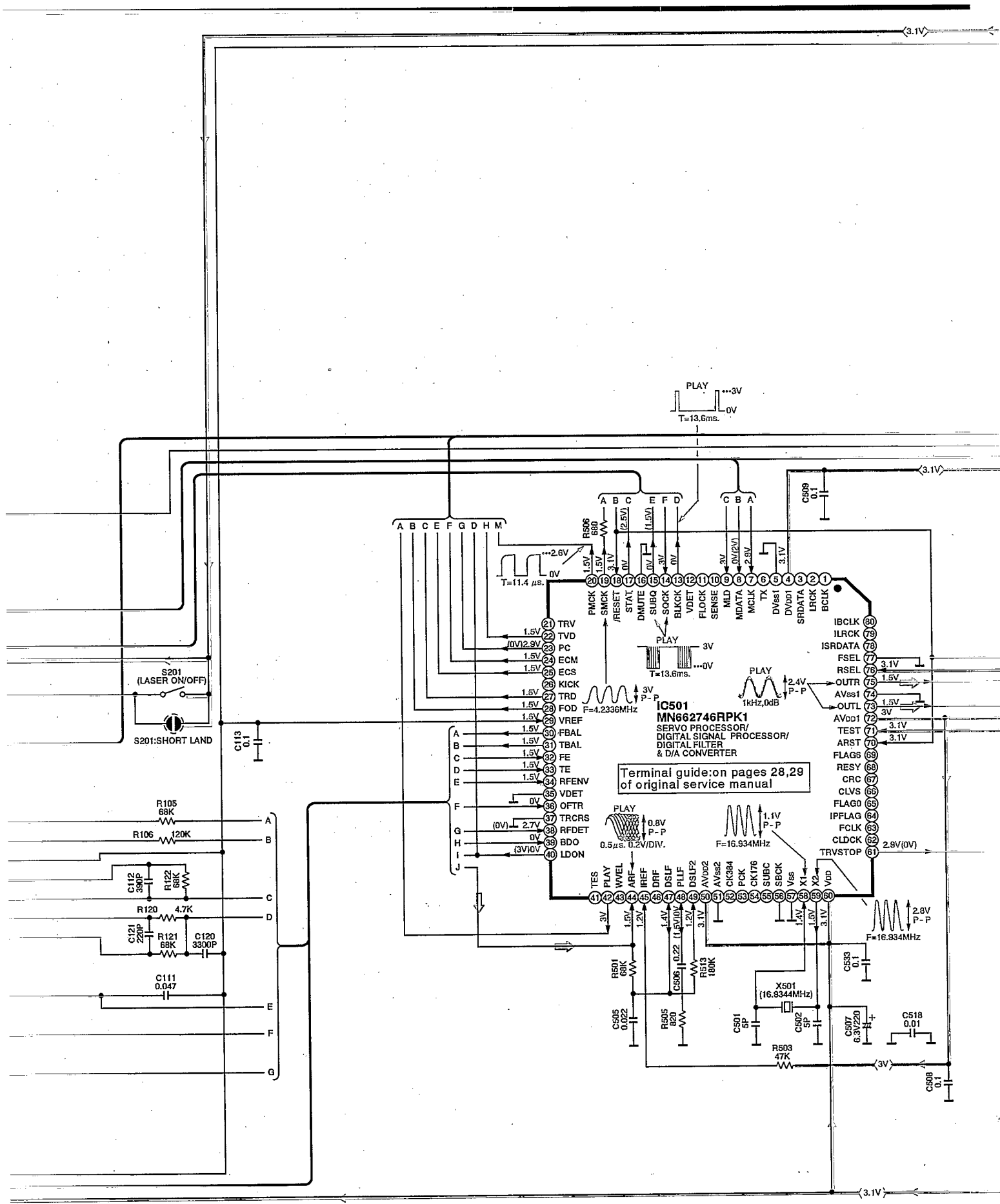

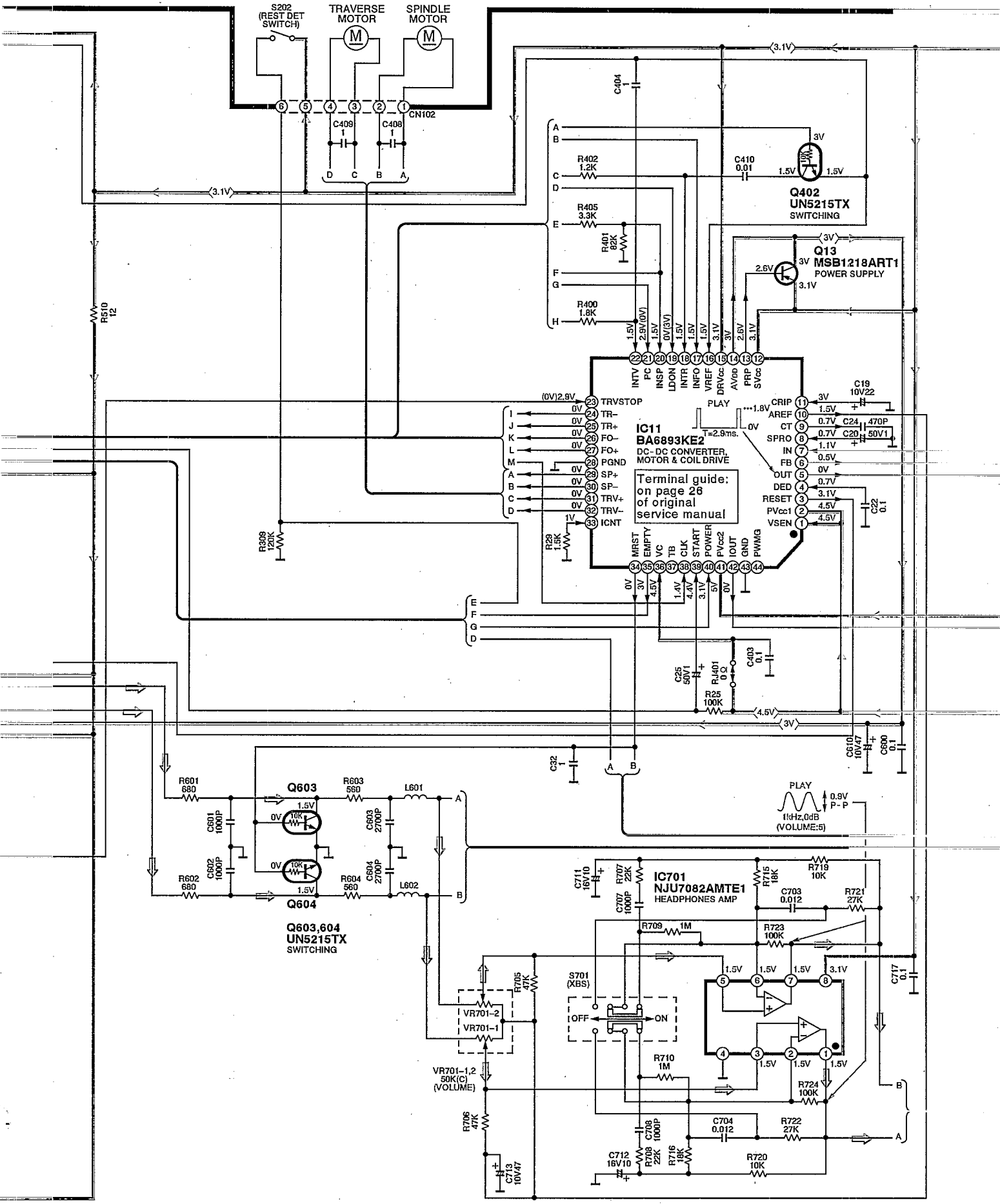

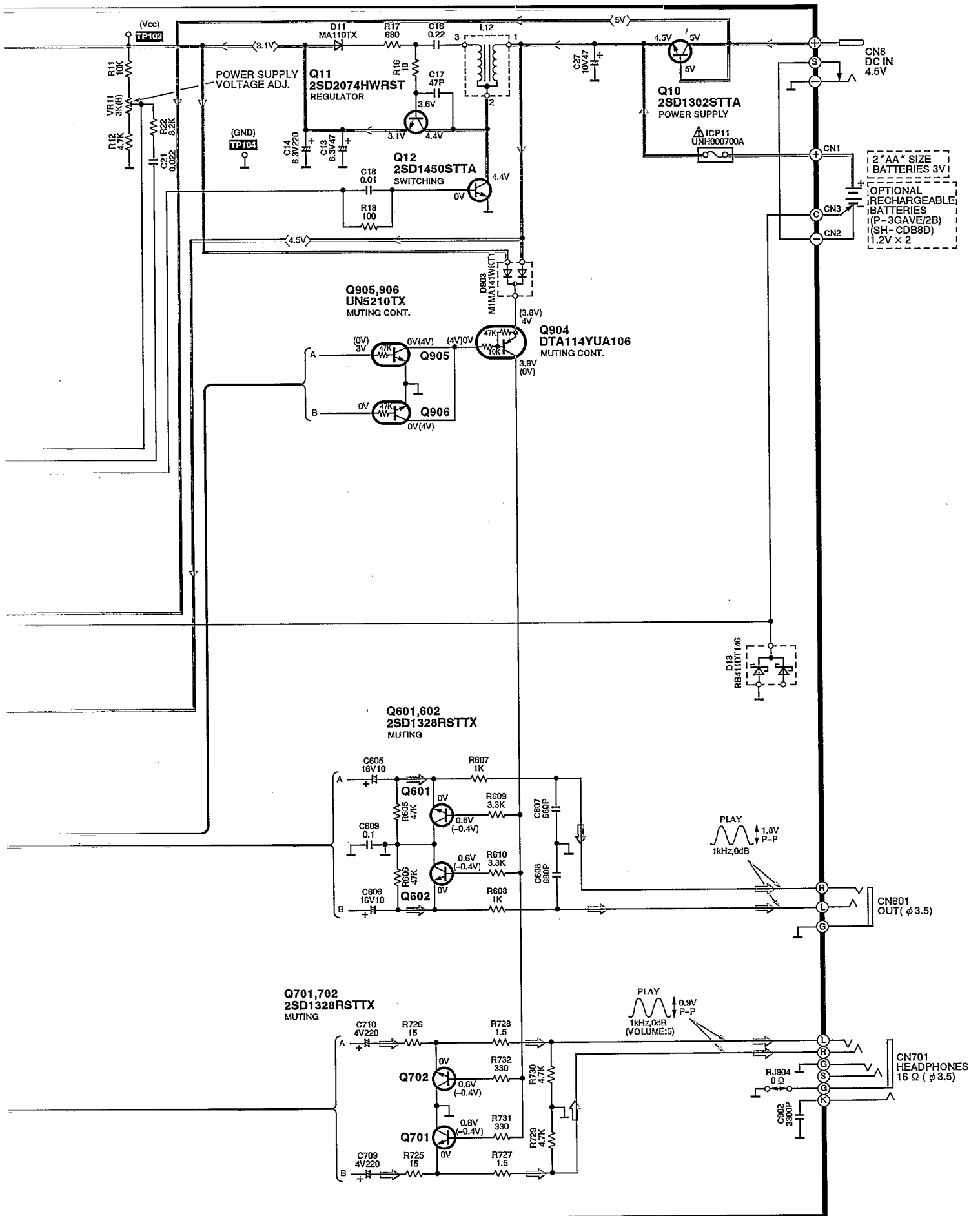

Printed Circuit Board and Wiring Connection Diagram

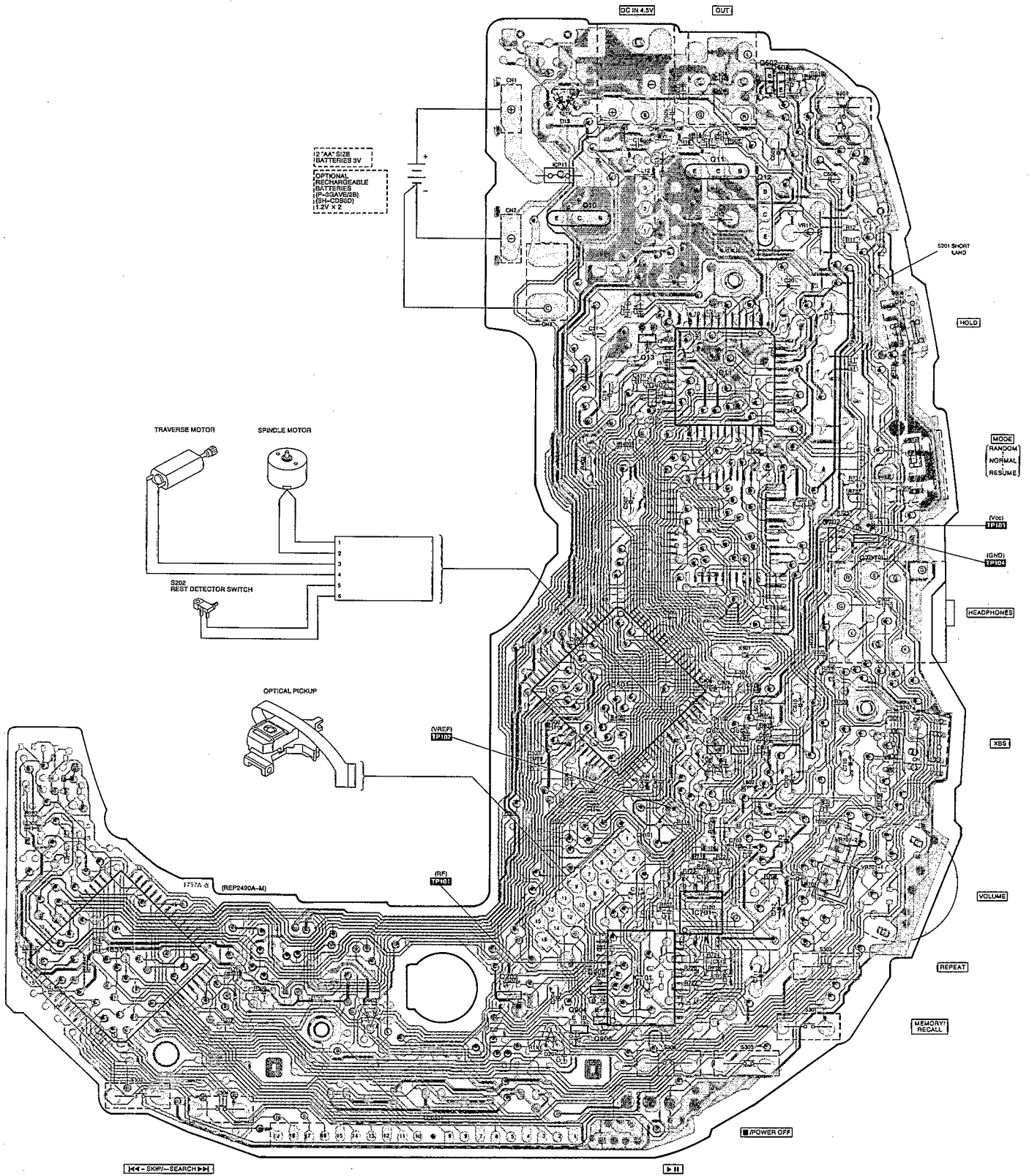

■ Replacement Parts List (Electrical)

Notes: *Important safety notice:

 Components identified by Δ mark have special characteristics important for safety.

Furthermore, special parts which have purposes of fire-retardant (resistors), high-quality sound (capacitors), low-noise (resistors), etc. are used.

When replacing any of components, be sure to use only manufacturer's specified parts shown in the parts list.

*The parenthesized indications in the Remarks columns specify the areas. (Refer to the cover page for area.)

Parts without these indications can be used for all areas.

*[M] Indicates in Remarks columns parts that are supplied by MESA.

Ref. No.	Part No.	Part Name & Description	Remarks	Ref. No.	Part No.	Part Name & Description	Remarks
		INTEGRATED CIRCUIT (S)		X501	RSXZ16M9M01T	OSCILLATOR	[M]
						CONNECTOR (S) /JACK (S)	
IC11	BA6893KE2	IC	[M]	CN1, 2	RJC93015-1	BATTERY TERMINAL	[M]
IC101	AN8837SBE1	IC	[M]	CN3	RJH5104	RECHARGEABLE TERMINAL	[M]
IC301	SC440303CFU	IC	[M]	CN8	RJJ43K09-C	DC IN JACK	[M]
IC501	MN662746RPK1	IC	[M]	CN101	RJS2A4716M1	CONNECTOR (16P)	[M]
IC701	NJU7082AMTE1	IC	[M]	CN102	RJS2A5106T1	CONNECTOR (6P)	[M]
		TRANSISTOR (S)		CN601	RJJD3S5ZB-C	OUT JACK	[M]
				CN701	RJJ33TK07-C	HEADPHONES JACK	[M]
Q10	2SD1302STTA	TRANSISTOR	[M]			DISPLAY	
Q11	2SD2074HWRST	TRANSISTOR	[M]	LCD301	RSL5156-1L	LCD	[M]
Q12	2SD1450STTA	TRANSISTOR	[M]			SWITCH (ES)	
Q13	MSB1218ART1	TRANSISTOR	[M]	S201	ESE11SV6	SW	[M]
Q203	MSB709RST1	TRANSISTOR	[M]	S301-306	EVQ21405R	SW	[M]
Q402	UN5215TX	TRANSISTOR	[M]	S307	RSS3A007-1A	SW	[M]
Q601, 602	2SD1328QRSTX	TRANSISTOR	[M]	S308	RSS2A010-1A	SW	[M]
Q603, 604	UN5215TX	TRANSISTOR	[M]	S701	RSS2B028-A	SW	[M]
Q701, 702	2SD1328QRSTX	TRANSISTOR	[M]				
Q904	DTA114YUA106	TRANSISTOR	[M]				
Q905, 906	UN5210TX	TRANSISTOR	[M]				
		DIODE (S)					
D11	MA110TX	DIODE	[M]				
D13	RB411DT146	DIODE	[M]				
D301	M1MA141WKT1	DIODE	[M]				
D903	M1MA141WKT1	DIODE	[M]				
		IC PROTECTOR (S)					
ICP11 Δ	UNH00700A	IC PROTECTOR	[M]				
		VARIABLE RESISTOR (S)					
VR11	EVNDXAA00B33	V. R	[M]				
VR701	EVUTUFB11C54	V. R	[M]				
		COIL (S)					
L12	RLZ0028T-0	COIL	[M]				
L601, 602	RLBV102V-Y	COIL	[M]				
		OSCILLATOR (S)					

Resistors and Capacitors

Notes : * Capacity values are in microfarads (μF) unless specified otherwise, P=Pico-farads (pF) F=Farads (F)
 * Resistance values are in ohms, unless specified otherwise, 1K=1,000 (OHM) , 1M=1,000k (OHM)

Ref. No.	Part No.	Values & Remarks	Ref. No.	Part No.	Values & Remarks	Ref. No.	Part No.	Values & Remarks
		RESISTORS	R731, 732	ERJ3GEYJ331V	1/16W 330 [M]	C600	ECUZNC104ZFV	25V 0.1U [M]
			R920	ERJ3GEYJ473V	1/16W 47K [M]	C601, 602	ECUV1H102KBV	50V 1000P [M]
			R928	ERJ3GEYJ473V	1/16W 47K [M]	C603, 604	ECUV1H272KBV	50V 2700P [M]
R11	ERJ3GEYJ103Z	1/16W 10K [M]				C605, 606	ECEA1CKA100I	16V 10U [M]
R12	ERJ3GEYJ472V	1/16W 4.7K [M]			CHIP JUMPER(S)	C607, 608	ECUV1H681KBV	50V 680P [M]
R16	ERJ3GEYJ100V	1/16W 10 [M]				C609	ECUZNC104ZFV	25V 0.1U [M]
R17	ERJ3GEYJ681V	1/16W 680 [M]	RJ401	ERJ3GEYOR00V	CHIP JUMPER [M]	C610	RCE1AKA470IG	10V 47U [M]
R18	ERJ3GEYJ101V	1/16W 100 [M]	RJ904	ERJ3GEYOR00V	CHIP JUMPER [M]	C703, 704	ECUV1E123KBV	25V 0.012U [M]
R22	ERJ3GEYJ822V	1/16W 8.2K [M]				C707	ECUV1H102KBN	50V 1000P [M]
R25	ERJ3GEYJ104Z	1/16W 100K [M]			CAPACITORS	C708	ECUV1H102KBV	50V 1000P [M]
R29	ERJ3GEYJ152V	1/16W 1.5K [M]				C709, 710	ECEA0GPK221I	4V 220U [M]
R105	ERJ3GEYJ683V	1/16W 68K [M]	C13	RCE0JSC4701X	6.3V 47U [M]	C711, 712	ECEA1CPK100I	16V 10U [M]
R106	ERJ3GEYJ124V	1/16W 120K [M]	C14	RCE0JKA221IG	6.3V 220U [M]	C713	RCE1AKA470IG	10V 47U [M]
R113	ERJ3GEYJ101V	1/16W 100 [M]	C16	ECUVNC224KBN	16V- 0.22U [M]	C717	ECUZNC104ZFV	16V 0.1U [M]
R114	ERJ3GEYJ330V	1/16W 33 [M]	C17	ECUV1H470KCV	50V 47P [M]	C902	ECUV1H332KBV	50V 3300P [M]
R120	ERJ3GEYJ472V	1/16W 4.7K [M]	C18	ECUV1E103KBV	25V 0.01U [M]			
R121, 122	ERJ3GEYJ683V	1/16W 68K [M]	C19	ECEA1AKA220I	10V 22U [M]			
R208	ERJ3GEYJ4R7V	1/16W 4.7 [M]	C20	ECEA1HKA010I	50V 1U [M]			
R209	ERJ3GEYJ223V	1/16W 22K [M]	C21	ECUV1C223KBV	16V 0.022U [M]			
R301-303	ERJ3GEYJ473V	1/16W 47K [M]	C22	ECUZNC104ZFV	16V 0.1U [M]			
R309	ERJ3GEYJ124V	1/16W 120K [M]	C24	ECUV1H471KBV	50V 470P [M]			
R313	ERJ3GEYJ102Z	1/16W 1K [M]	C25	ECEA1HKA010I	50V 1U [M]			
R317, 318	ERJ3GEYJ104Z	1/16W 100K [M]	C27	RCE1AKA470IG	10V 47U [M]			
R319	ERJ3GEYJ334V	1/16W 330K [M]	C32	ECUVNC105ZFN	16V 1U [M]			
R400	ERJ3GEYJ182V	1/16W 1.8K [M]	C101	ECUV1C104KBV	16V 0.1U [M]			
R401	ERJ3GEYJ823V	1/16W 82K [M]	C103	ECUV1C223KBV	16V 0.022U [M]			
R402	ERJ3GEYJ122V	1/16W 1.2K [M]	C111	ECUVNC473KBV	16V 0.047U [M]			
R405	ERJ3GEYJ332V	1/16W 3.3K [M]	C112	ECUV1H391KBV	50V 390P [M]			
R501	ERJ3GEYJ683V	1/16W 68K [M]	C113	ECUVNE104ZFN	25V 0.1U [M]			
R503	ERJ3GEYJ473V	1/16W 47K [M]	C114	ECUZNC104ZFV	16V 0.1U [M]			
R505	ERJ3GEYJ821V	1/16W 820 [M]	C115	ECUV1C223KBV	16V 0.022U [M]			
R506	ERJ3GEYJ681V	1/16W 680 [M]	C120	ECUV1H332KBV	50V 3300P [M]			
R510	ERJ3GEYJ120V	1/16W 12 [M]	C121	ECUV1H221KBV	50V 220P [M]			
R513	ERJ3GEYJ184V	1/16W 180K [M]	C204	RCE1AKA470IG	10V 47U [M]			
R601, 602	ERJ3GEYJ681V	1/16W 680 [M]	C301, 302	ECUZNC104ZFV	16V 0.1U [M]			
R603, 604	MCR03PZHJ561	1/16W 560 [M]	C403	ECUZNC104ZFV	16V 0.1U [M]			
R605, 606	ERJ3GEYJ473V	1/16W 47K [M]	C404	ECUVNC105ZFN	16V 1U [M]			
R607, 608	ERJ3GEYJ102Z	1/16W 1K [M]	C405	ECUV1C104KBV	16V 0.1U [M]			
R609, 610	ERJ3GEYJ332V	1/16W 3.3K [M]	C407	ECUZNC104ZFV	16V 0.1U [M]			
R705, 706	ERJ3GEYJ473V	1/16W 47K [M]	C408, 409	ECUVNC105ZFN	16V 1U [M]			
R707, 708	ERJ3GEYJ223V	1/16W 22K [M]	C410	ECUV1E103KBV	25V 0.01U [M]			
R709, 710	ERJ3GEYJ105V	1/16W 1M [M]	C501, 502	ECUV1H050CCV	50V 5P [M]			
R715, 716	ERJ3GEYJ183V	1/16W 18K [M]	C503	ECUV1H561KBV	50V 560P [M]			
R719, 720	ERJ3GEYJ103Z	1/16W 10K [M]	C505	ECUV1C223KBV	16V 0.022U [M]			
R721, 722	ERJ3GEYJ273V	1/16W 27K [M]	C506	ECUVNC224KBN	16V 0.22U [M]			
R723, 724	ERJ3GEYJ104Z	1/16W 100K [M]	C507	RCE0JKA221IG	6.3V 220U [M]			
R725, 726	ERJ3GEYJ150V	1/16W 15 [M]	C508, 509	ECUZNC104ZFV	25V 0.1U [M]			
R727, 728	ERJ3GEYJ1R5V	1/16W 1.5 [M]	C518	ECUV1E103KBV	25V 0.01U [M]			
R729, 730	ERJ3GEYJ472V	1/16W 4.7K [M]	C533	ECUZNC104ZFV	25V 0.1U [M]			

540

■ Replacement Parts List

● Cabinet Colour (H)Gray Type, (A)Blue Type

Ref. No.	Change of Part No.		Part Name & Description	Remarks
	SL-S120 (E)	➔ SL-S118 (E)		
CABINET PARTS				
1	RFKJLS120E-H	RFKJLS118E-H	BOTTOM CABINET ASS'Y	[M]
7	RYF0441-H	RYF0441C-H	CD COVER ASS'Y (H)	[M]
7	RYF0441-A	RYF0441C-A	CD COVER ASS'Y (A)	[M]
PACKING MATERIALS				
P1	RPK0896	RPK0836	GIFT BOX (H)	[M]
P1	RPK0834	RPK0897	GIFT BOX (A)	[M]
P2	RPQ0753	RPQ0752	SPACER	[M]
ACCESSORIES				
A1△	RFEA401E-3S	_____	AC ADAPTER	[M] Deletion
A5	_____	RQT3743-D	INSTRUCTION MANUAL	[M] Addition <IA>
A5	_____	RQT3744-H	INSTRUCTION MANUAL	[M] Addition <IB>
A5	_____	RQT3985-J	INSTRUCTION MANUAL	[M] Addition <IC>
A7	RP-BP60EYS	_____	BATTERY	[M] Deletion
A7-1	RFKNLS370-K	_____	BATTERY CASE	[M] Deletion

Note:

The " <IA>, <IB> and <IC> " mark in Remarks indicate language of instruction manual.

<IA> : German, Italian

<IB> : French, Dutch

<IC> : Danish