

# Service Manual

**COMPACT**  
**disc**  
**DIGITAL AUDIO**

Please file and use this manual together with the service manual for Model No. SL-S230, Order No. AD9803046C1.

## Portable CD Player SL-S230

### Colour

(S) ..... Silver Type  
(A) ..... Blue Type

### Areas

(EB) ..... Great Britain.  
(EG) ..... Germany.  
(GC) ..... Asia, Latin America, Middle East and Africa.  
(GN) ..... Australia, New Zealand.

**MASH** \*1  
multi-stage noise shaping

**Notes:** • This simplified service manual is provided to indicate the differences between the original No. SL-S230 (P)(PC) and the subsequent model No. SL-S230 (EB)(EG)(GC)(GN).

## Traverse Deck: RAE0145Z Mechanism Series

## Specifications

### Audio

No. of channels: 2 channels (left and right, stereo)  
Frequency response: 20 to 20,000 Hz (+0.5 dB to -1.5dB)  
Output voltage: 0.6 V (50 kΩ)  
S/N: more than 94 dB\*2  
Wow and flutter: Below measurable limit  
DA converter: 1 bit, MASH\*1  
Headphones output level: max. 9 mW+9 mW/16 Ω (adjustable)

### Pick up

Light source: Semiconductor laser  
Wavelength: 780 nm

### General

Operational temperature range: 0°C – 40°C (32°F – 104°F)  
Rechargeable temperature range: 5°C – 40°C (41°F – 104°F)  
Power supply: DC 4.5 V  
Power consumption:

Power source	Anti-shock OFF/ON
AC adaptor	3.0 W/ 3.2 W
Battery (DC 3 V)	0.4 W/ 0.4 W

When recharging: 3.6 W

### Play time:

When used in hold mode, at 25°C (77°F) temperature and on flat and stable surface.

Batteries used	Anti-shock OFF/ON	Area
2 alkaline batteries*3	About 20 h/ 20 h	All areas
Rechargeable batteries (P-3GAVE/2B)*3	About 10 h/ 10 h	(EB)(EG)
Rechargeable battery (P-3GAVT/2B)*3	About 10 h/ 10 h	(GC)(GN)
Rechargeable battery (SH-CDB8D)*3	About 6 h/ 6 h	All areas

• The play time may be less depending on the operating conditions.

### Recharging time:

P-3GAVE/2B; About 5 h [for (EB)(EG) areas]  
P-3GAVT/2B; About 5 h [for (GC)(GN) areas]  
SH-CDB8D; About 3 h [for all areas]

### Dimensions (W×H×D):

128 × 27.8 × 144 mm  
Weight: 265 g with batteries  
220 g without batteries

**Notes:** Specifications are subject to change without notice.

Weight and dimensions are approximate.

\*1 MASH is a trademark of NTT.

\*2 This specification was measured in Anti-shock OFF mode.

\*3 These batteries are not included.

## Replacement Parts List (Cabinet Parts)

Note: \* [A]...Blue

Ref. No.	Change of Parts No.		Part Name & Description	Remarks
	(P)	→ (EB/EG/GC/GN)		
<b>CABINET PARTS</b>				
1	RFKJLS230P-S	RFKJLS230EBA	BOTTOM CABINET ASS'Y	(EB)
		RFKJLS230EGA		(EG)
		RFKJLS230GCS		(GC)
		RFKJLS230GNS		(GN)
7	—————	RYF0460-A	CD COVER ASS'Y	[A]

### ⚠ WARNING

This service information is designed for experienced repair technicians only and is not designed for use by the general public. It does not contain warnings or cautions to advise non-technical individuals of potential dangers in attempting to service a product.

Products powered by electricity should be serviced or repaired only by experienced professional technicians. Any attempt to service or repair the product or products dealt with in this service information by anyone else could result in serious injury or death.

**Panasonic**®

© 1998 Matsushita Electric Industrial Co., Ltd.  
All rights reserved. Unauthorized copying and distribution is a violation of law.

## ■ Replacement Parts List (Accessories and Packing Materials)

**Notes:**

- \* Important safety notice:  
Components identified by  $\triangle$  mark have special characteristics important for safety.  
Furthermore, special parts which have purposes of fire-retardant (resistors), high-quality sound (capacitors), low-noise (resistors), etc. are used.  
When replacing any of components, be sure to use only manufacturer's specified parts shown in the parts list.
- \* All parts are supplied by MESA.  
The "<IA> <IB> <IC> <ID> <IE>" marks in Remarks indicate language of instruction manual.  
<IA> : English  
<IB> : English, Spanish, Chinese  
<IC> : English, Spanish, Swedish  
<ID> : German, Italian, French  
<IE> : Dutch, Danish, Russian
- \* [A]...Blue [S]...Silver

Ref. No.	Part No.	Part Name & Description	Pcs.	Remarks
<b>ACCESSORIES</b>				
$\triangle$ A1	RFEA403A-S	AC ADAPTOR	1	(GN)
$\triangle$ A1	RFEA403Z-S	AC ADAPTOR	1	(GC)
$\triangle$ A1	RFEA403B-S	AC ADAPTOR	1	(EB)
$\triangle$ A1	RFEA414E-M	AC ADAPTOR	1	(EG)
A2	RFEV317P-KS	STEREO HEADPHONES	1	
A3	RQCB0169	SERVICE CENTER LIST	1	
A4	RQT4324-B	OPERATING INSTRUCTIONS	1	(GN) <IA>
A5	RQT4331-K	OPERATING INSTRUCTIONS	1	(GC) <IB>
A6	RQT4325-E	OPERATING INSTRUCTIONS	1	(EG) <IC>
A7	RQT4327-D	OPERATING INSTRUCTIONS	1	(EG) <ID>
A8	RQT4328-H	OPERATING INSTRUCTIONS	1	(EG) <IE>
$\triangle$ A9	SJP5213-1	PLUG	1	(GC)
<b>PACKING MATERIALS</b>				
P1	RPK0996	PACKING CASE	1	[S]
P1	RPK1045	PACKING CASE	1	[A]
P2	RPQ0753	SPACER	1	(EB)(EG)(GN)
P3	RPQ0836	PAD	1	
P4	RPF0046	PROTECTION BAG (F.B.)	1	
P5	RPF0111	PROTECTION BAG (UNIT)	1	
P6	RPQ0683	PAD	1	(GC)

## ■ Packaging

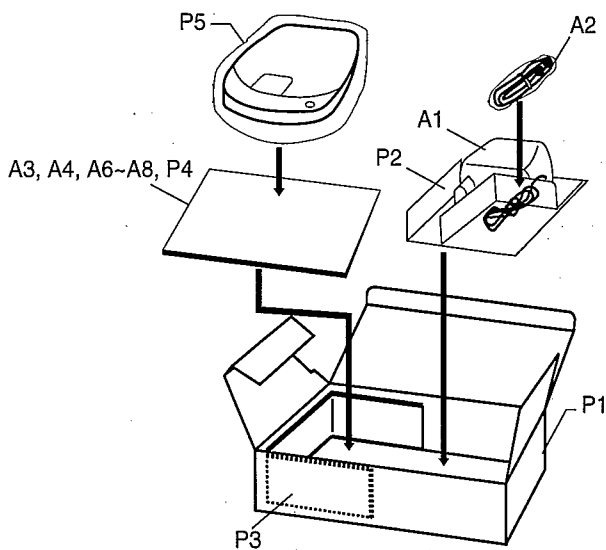

For (EB) (EG) (GN) areas

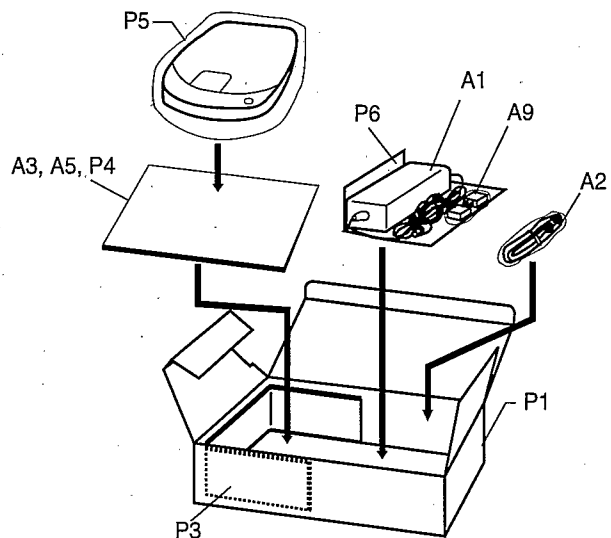

For (GC) area

# Service Manual

## Portable CD Player SL-S230



SL-S230(P)

**COMPACT**  
**disc**  
**DIGITAL AUDIO**

**MASH\***  
multi-stage noise shaping

\* MASH is a trademark of NTT.

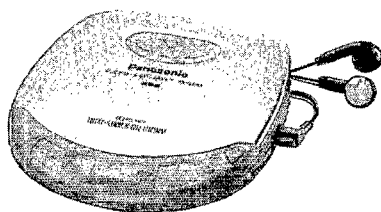

SL-S230(PC)

**Colour**  
(S) ..... Silver Type

**Areas**  
(P) ..... U.S.A.  
(PC) ..... Canada.

### Traverse Deck: RAE0145Z Mechanism Series

## Specifications

#### Audio

**No. of channels:** 2 channels (left and right, stereo)  
**Frequency response:** 20 to 20,000 Hz (+0.5 dB to -1.5 dB)  
**Output voltage:** 0.6 V (50 k $\Omega$ )  
diameter 3.5 stereo mini jack  
**S/N:** more than 94 dB  
(Anti-shock memory OFF)  
**Wow and flutter:** Below measurable limit  
**DA converter:** 1 bit, MASH\*  
**Headphone output level:** max.9 mW+9 mW/16  $\Omega$  (adjustable)  
stereo mini jack diameter 3.5

#### Pickup

**Light source:** Semiconductor laser  
**Wavelength:** 780 nm

#### General

**Operation temperature range:** 0-40 degree (32-104 fahrenheit)  
**Rechargeable temperature range:** 5-40 degree (41-104 fahrenheit)  
**Power supply:** DC 4.5 V

**Power consumption:** Anti-shock memory OFF/ON  
**AC adaptor;** 2.8 W / 3.0 W  
**Battery (DC 3V);** 0.4 W / 0.4 W  
**When recharging;** 3.6 W

#### Playing time

(When used in hold mode, at 25 degree (77 fahrenheit) temperature and on flat and stable surface.)

**Battery used:** Anti-shock memory OFF/ON  
**Panasonic Alkaline dry cell batteries(LR6, 2pcs.);**  
Approx. 20 h / 20 h

**Optional Rechargeable batteries (P-3GAVA/2B);**  
Approx. 10 h / 10 h

The play time may be less depending on the operating conditions.

#### Recharging time:

**P-3GAVA;** Approx. 5 h

#### Dimensions (W x H x D):

128 x 27.8 x 144 mm  
(5<sup>1</sup>/<sub>16</sub>" / 1<sup>3</sup>/<sub>32</sub>" / 5<sup>11</sup>/<sub>16</sub>" )

#### Weight:

265 g (9.4 ounce) with batteries  
220 g (7.8 ounce) without batteries

**Note:** Specifications are subject to change without notice.  
Weight and dimensions are approximate.

### ! WARNING

This service information is designed for experienced repair technicians only and is not designed for use by the general public. It does not contain warnings or cautions to advise non-technical individuals of potential dangers in attempting to service a product. Products powered by electricity should be serviced or repaired only by experienced professional technicians. Any attempt to service or repair the product or products dealt with in this service information by anyone else could result in serious injury or death.

# Panasonic<sup>®</sup>

© 1998 Matsushita Electric Industrial Co., Ltd.  
All rights reserved. Unauthorized copying and distribution is a violation of law.

## ■ Contents

	Page		Page
Precaution of Laser Diode .....	2	Checking the Operation Problems	
Location of Controls .....	2	on the Traverse Deck (Optical Pickup) .....	11
HOLD Function .....	2	Automatic Adjustment Results Display Function	
Accessories .....	2	(Self-check Function) .....	12,13
Power Supply Preparations .....	3	Measurement and Adjustments .....	13,14
Troubleshooting Guide .....	3	Schematic Diagram .....	15~20
Sequential Play .....	4	Type Illustration of IC's, Transistors and Diodes .....	15
Other Play Methods .....	5	Terminal Function of IC's .....	21~25
Anti-Shock Function .....	5	Printed Circuit Board and Wiring Connection Diagram .....	26,27
Using the Unit Optional Accessories .....	6	Block Diagram .....	28~31
Cautions .....	6	Replacement Parts List .....	32~34
Handling Precaution for Traverse Deck .....	7	Cabinet Parts Location .....	34
Outline of 10 - Second Keeper Technique Used		Packaging .....	35
for Prevention of Sound from Skipping .....	7		
Operation Checks			
and Component Replacement Procedures .....	8~10		

## ■ Precaution of Laser Diode

**CAUTION:** This unit utilizes a class 1 laser. Invisible laser radiation is emitted from the optical pickup lens when the unit is turned on :

1. Do not look directly into the pickup lens.
2. Do not use optical instruments to look at the pickup lens.
3. Do not adjust the preset variable resistor on the optical pickup.
4. Do not disassemble the optical pickup unit.
5. If the optical pickup is replaced, use the manufactures specified replacement pickup only.
6. Use of control or adjustments or performance of procedures other than those specified herein may result in hazardous radiation exposure.

## ■ Location of Controls

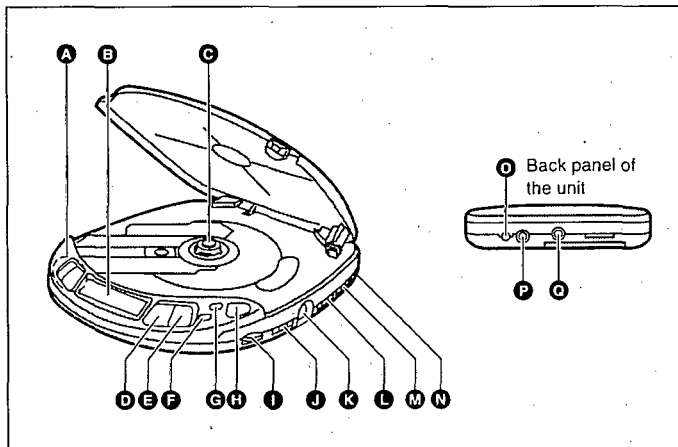

- |  |  |
|--|--|
| <p><b>A</b> Skip/search buttons<br/>( ◀◀, ▶▶  •SKIP = SEARCH)</p> <p><b>B</b> Display</p> <p><b>C</b> CD release button (PUSH)</p> <p><b>D</b> Play/pause button (▶   )</p> <p><b>E</b> Stop/power off button<br/>(■, POWER OFF)</p> <p><b>F</b> Memory/recall button<br/>(MEMORY/RECALL)</p> <p><b>G</b> Repeat button (REPEAT)</p> <p><b>H</b> Open button (OPEN)</p> <p><b>I</b> Headphones volume control<br/>(VOLUME)</p> | <p><b>J</b> XBS selector (XBS)</p> <p><b>K</b> Headphones jack (Ω)</p> <p><b>L</b> Play mode selector<br/>(RESUME, NORMAL, RANDOM)</p> <p><b>M</b> Hold switch (HOLD)</p> <p><b>N</b> Anti-shock switch<br/>(ANTI-SHOCK)</p> <p><b>O</b> Out jack (OUT)</p> <p><b>P</b> DC in jack<br/>(⊕ ⊖ DC IN 4.5 V)</p> <p><b>Q</b> Hole for car insulator mounting screw</p> |
|--|--|

## ■ HOLD Function

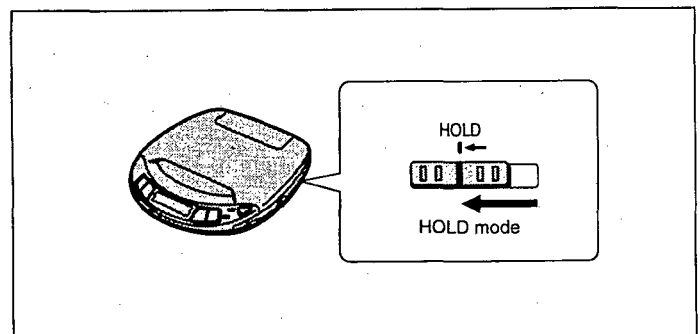

This function causes the unit to ignore short, accidental button presses. (The disc lid can still be opened and closed.)

**The HOLD function prevents the following:**

- Powering on the unit accidentally (which can cause the batteries to go dead).
- Play being cut off unexpectedly in the middle of a selection.

**To use the HOLD function**  
Set HOLD to the HOLD position.

### "hold" indication

When the unit is in hold status, pressing any button (other than the OPEN button) causes the indication "hold" to appear on the display.

### When the unit is powered off

The "hold" indication appears only when ▶ || button is pressed.

**Before operating the buttons**  
Be sure to move HOLD to release the unit from the hold mode.

## ■ Accessories

AC adaptor (RFEA415C-S) .....	1pc.	Stereo headphones (For U.S.A) (RFEV705P-KS) .....	1pc.	Stereo earphones (For Canada) (RFEV317P-KS) .....	1pc.
----------------------------------	------	--	------	--	------

## Power Supply Preparations

Refer to the specifications for information on operating times when using rechargeable batteries or dry-cell batteries.

### Using the AC adaptor

#### Connect the AC adaptor supplied.

The configuration of the AC adaptor differs according to the model.

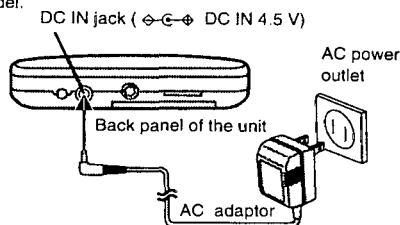

### 2 Connect the AC adaptor.

Refer to "Using the AC adaptor" for connection instructions.

When recharging starts, the "⏻" charging indicator flashes on and off on the unit's display.

#### Length of time needed to fully recharge

##### Optional batteries

P-3GAVA/2B: about 5 hours

SH-CDB8D: about 3 hours

(After recharging of the batteries is complete, the "⏻" charging indicator will continue to flash.)

### 3 When recharging is complete, unplug the AC adaptor from the power outlet and the DC IN jack.

### Using rechargeable batteries

Obtain the optional rechargeable batteries for SL-S230.

Be sure to recharge the batteries before using them. The unit cannot be used to charge rechargeable batteries other than those specifically designed for it.

- Supplied batteries (RP-BP60)
- Optional batteries (P-3GAVA/2B, SH-CDB8D)

#### Recharging procedure

### 1 Insert the special rechargeable batteries into the unit.

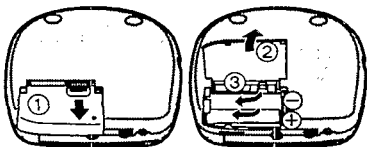

#### Notes

- Rechargeable batteries have a service life of approximately 300 charge-discharge cycles. If the operating time on one full charge becomes noticeably shorter than it used to be, the battery has reached the end of its service life and should be replaced.
- You can operate the unit with the AC adaptor while recharging the batteries, but it will lengthen the recharging time.
- The AC adaptor and rechargeable batteries may become warm while recharging is in progress. This is not a malfunction.

#### If the battery lid comes loose

Slide the lid back into place horizontally.

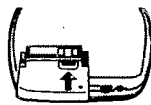

#### Removing batteries

Push up on the battery in the direction indicated by the arrow. Then lift it out.

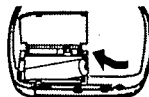

### Using the car adaptor

Be sure to obtain the car adaptor (SH-CDC9) for SL-S230, available as an optional accessory. The car adaptor can be used to recharge the unit's batteries while in the car.

#### CAUTION:

Use only car adaptor, Model: SH-CDC9 manufactured by Matsushita Electric Industrial Co., Ltd.

### Using dry-cell batteries (not included)

After disconnecting the AC adaptor, insert two "AA" (LR6) alkaline batteries.

The procedure for inserting and removing dry-cell batteries is identical to that for rechargeable batteries.

### Battery indicator

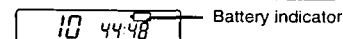

This indicator flashes on and off when the batteries are almost out of power. Power is cut off completely a short while later.

**Rechargeable batteries: Recharge batteries.**

**Dry-cell batteries: Replace batteries with new ones.**

#### Notes

- The length of time the unit will continue to operate between when the battery indicator starts flashing and when the power is cut off differs depending on the type of batteries used.
- The battery indicator may not flash if rechargeable batteries, other than those designated by Panasonic, are used.

If the unit malfunctions or freezes during use, then disconnect the power sources (the AC adaptor and batteries). Re-connect the power source and continue operation.

## Troubleshooting Guide

Problem	Check this
Cannot close cover.	Is the disc properly secured in place?
Cannot play discs.	<ul style="list-style-type: none"> <li>• Is the unit in hold status?</li> <li>• Is the disc properly secured in place?</li> <li>• Is there condensation on the lens? (Wait for about an hour and then try again.)</li> </ul>
Cannot remove disc.	Did you press the PUSH button to release the disc?
Tracks on disc do not play in order, starting with the first track.	Is the RESUME, NORMAL, RANDOM (play mode selector) slider in the NORMAL position?
Cannot hear music—too noisy.	<ul style="list-style-type: none"> <li>• Is the headphones/earphones plug inserted all the way?</li> <li>• Is the plug dirty? (Wipe away dirt on plug.)</li> </ul>
TV picture is distorted. Radio reception is noisy.	Are you using the unit body too near a TV or tuner? (If the TV or tuner is connected to a simple indoor antenna, connect it to an outdoor antenna.)

# Sequential Play

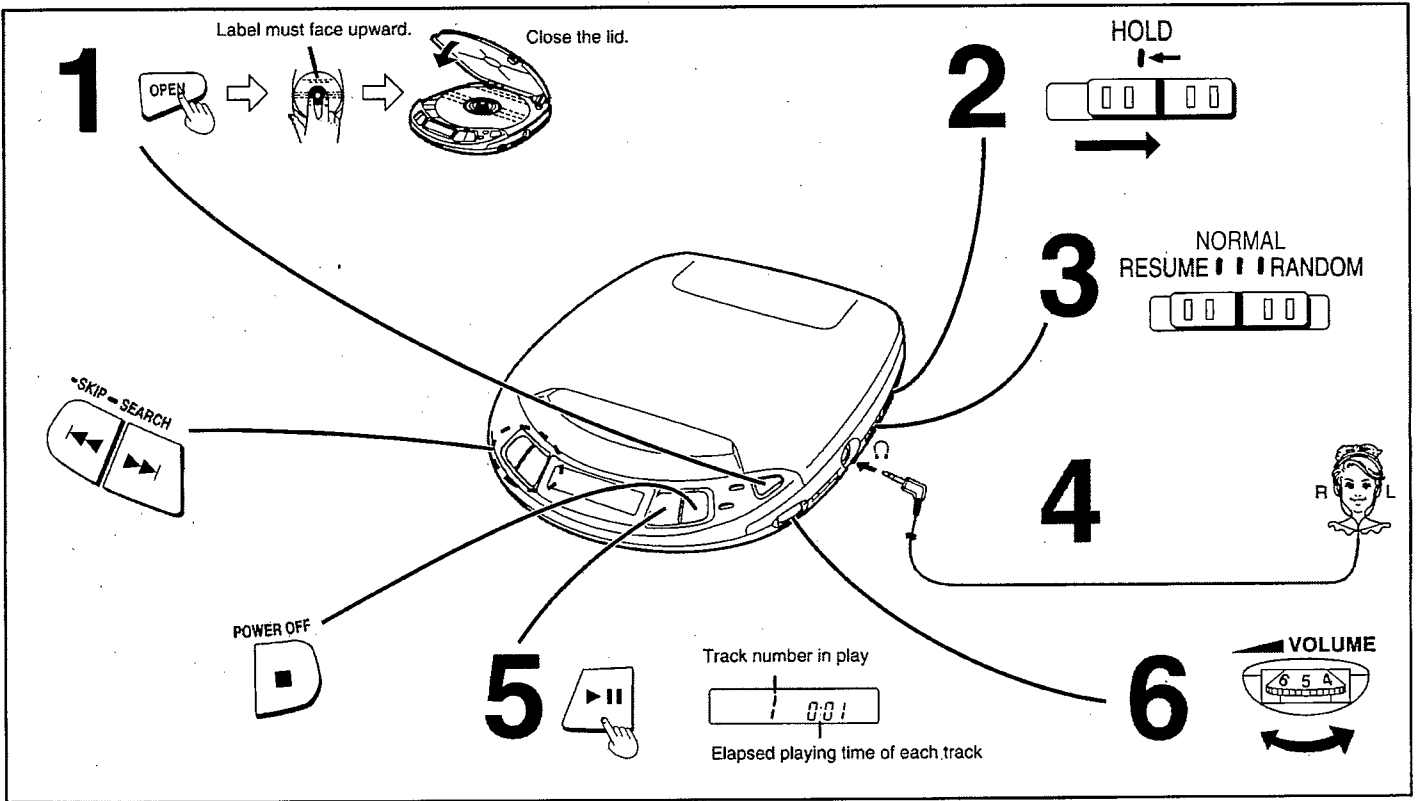

**Following steps 1-6.**

In step 4, connect the stereo headphones/earphones to the jack. (Plug in firmly.)

- Play stops automatically when all the tracks have been played.
- If the unit has been connected to the car audio system, adjust the volume level between 4 and 6 on the unit; then adjust the volume level on the system.

**For your reference:**

**"no disc" indication**

This indication appears for about 30 seconds if the button is pressed when no disc is loaded in the unit or if the disc is not completely seated.

**"OPEN" indication**

This indication appears for about 10 minutes when the cover is opened. (However, the indication does not appear when the unit is powered off.)

**Note**

Never insert foreign objects into the unit body.

**Removing discs**

After the disc has stopped rotating, press the PUSH button to release the disc. (To protect the disc, never open the cover while it is playing.)

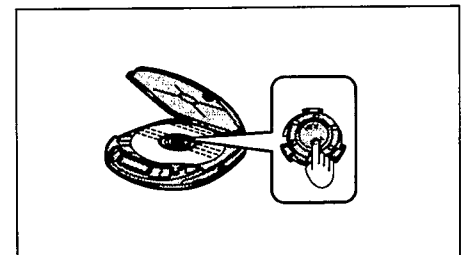

**Auto power off function**  
 If the unit is left in stop or paused status for approximately 10 minutes, the unit powers itself off automatically in order to prevent the battery from running down.  
 (If no disc is loaded in the unit, it powers itself off in 30 seconds.)

Operation	Button	Display/reference
<b>To pause play</b>	Press during play. 	 Press again to resume play
<b>To stop play</b> <b>Stop mode</b>	Press during play. 	Total number of tracks  Total playing time
<b>To turn off the unit</b> <b>Off mode</b>	Press during stop mode. 	
<b>Skip forward/backward</b> <b>(skip function)</b>	Press during play. (Backward) (Forward) 	<ul style="list-style-type: none"> <li>• During program play, these buttons are used to skip forward or back through the programmed sequence of tracks</li> <li>• During random play, the skip buttons cannot be used to skip back to tracks that were played previously in the random sequence.</li> <li>• During program play, random play or 1 track repeat play, search operation is limited to the current track only.</li> </ul>
<b>Rapid forward/backward</b> <b>(search function)</b>	 Keep depressed during play.	



## Other Play Methods

The letter such as **A** in the various illustrations in the "Location of Control" section.

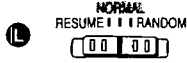

### Skip play

The disc plays from the specific track through to the end, then play stops automatically.

**Preparation:** Put unit in stop mode.

- 1 
- 2 **Select the desired track.** 
- 3 

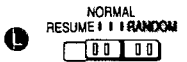
### Random play

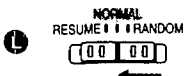
- 1 
  - 2 
- Release** 

#### For your reference:

- It is also possible to press the **▶▶** while the unit is in stop status to change the first track to be played. (All tracks are played eventually, regardless of which is played first.)
- Program play is not possible in the random mode.

### Resume play

This function allows you to listen from the beginning of the track where play stopped because the unit was powered off (or switched to stop status). It is useful when listening to CDs in the car, etc.

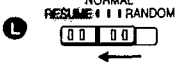
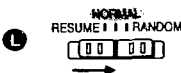
- 1 
- 2 **Release** 





#### For your reference:

- If the RESUME, NORMAL, RANDOM (play mode selector) slider is put in the RESUME position, the all-repeat function will be activated automatically as soon as the unit is powered on.
- If power is cut off near the end of a track (power off status), playback may resume from the beginning of the next track.
- If the unit is powered off while a disc was playing and then a new disc is inserted, play will begin from the middle of the new disc because the unit remembers the position where play stopped on the old disc.

### Program play

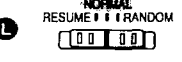
Up to 24 tracks can be entered in the program.

**Preparation:** Put unit in stop mode.

- 1 
- 2 **Select the desired track.** 
- 3 **Register in sequence.** (The indication "M" and the programmed sequence appear on the display panel.) 
- 4 **Repeat steps 2 and 3 to program all the desired tracks.**
- 5 

- **To program the same track in the sequence more than once**

After step 3, press MEMORY/RECALL the desired number of times.

- **If "F" is displayed**

No more tracks may be added to the sequence.

- **To confirm the contents of the programmed sequence**

Press MEMORY/RECALL while the disc is playing. (The number of the programmed tracks appear on the display panel in sequence.)

- **To delete the entire programmed sequence**

Press **■**, POWER OFF.

### Repeat function

Press REPEAT while disc is playing or when unit is in stop status.



#### For your reference:

If REPEAT is pressed during program play, only the tracks in the program are repeated. (The indication "ALL" is not displayed.)

The setting is switched in the sequence indicated below each time REPEAT is pressed.

**1-track repeat (1 ↻)** ←

One track is repeated.

**All-track repeat (ALL ↻)**

All the tracks on the disc are repeated.

**Cancel** \_\_\_\_\_

### Changing the sound quality

#### XBS ON:

Select this setting to boost the low-range response.

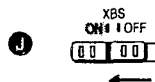



#### OFF:

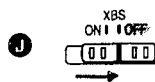



Select this setting to turn off the XBS function.

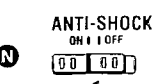

## Anti-Shock Function

Anti-shock works by reading audio data and storing it in memory (up to 10 seconds worth). The unit then fills in interruptions caused by bumps and vibrations with data from the memory. This unit also incorporates a powerful anti-shock mechanism that prevents skipping caused when play speed is changed by swiving of the unit.

- 1 
- 2 

M.RESERVE indicator status	Unit body status	Play status (audio data status)
	Stable	Normal (plenty of data is stored)
	Bump encountered	Normal (stored data is used)
	Bumping stops	Normal (data again starts to be stored)
	Bumps continue repeatedly	Sound is interrupted (data buffer empty)

#### Notes

- The position of the ANTI-SHOCK slider can be changed during play but this may cause a slight interruption in the sound because the disc's rotation speed changes.
- During anti-shock operation, the disc rotates at a higher rate than usual in order to collect extra audio data. This may cause the batteries to run out faster and could result in a slight increase in disc rotation noise.

#### Using the unit with an audio system

The ANTI-SHOCK uses digital signal compression technology. It is recommended that the ANTI-SHOCK be kept in the OFF position if the unit is connected to a home audio system.

## Using the Unit Optional Accessories

### Using the unit with an audio system

Using a stereo connection cable (not included), you can hear CDs on your audio system.

- Connect the cable to the amplifier after turning off its power.
- Do not connect the cable to the PHONO jacks on the amplifier.
- Obtain the optional connecting cable if the amplifier comes with mini-phone jacks.
- Adjust the volume on the amplifier.

#### Note

Sound quality changes when XBS is selected, but volume is reduced by approximately fifty percent.

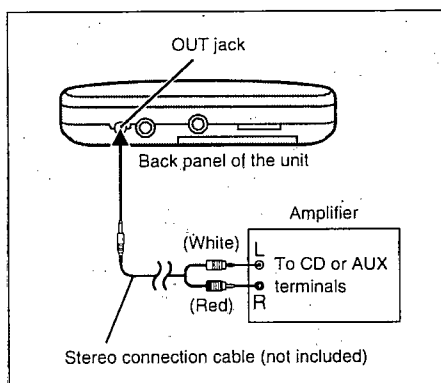

### Using the unit with a car audio system

#### Items to be purchased

For connection to the car audio system:  
Car stereo cassette adaptor (SH-CDM10A)

**Connect the car stereo cassette adaptor to the unit's headphones jack. (When doing this, keep the unit's VOLUME control at a setting between 4 and 6.)**

#### For securing the unit and connecting the power supply:

- Car adaptor (SH-CDC9)
- Car mounting kit (SH-CDF7)  
Car mounting arm, Car insulator

#### Note

It may not be possible to use the unit with some types of car stereo owing to restrictions imposed by the construction of the car stereo cassette adaptor.

For further details, refer to the instructions of the part concerned.

## Cautions

### Listening caution



Do not play your headphones or earphones at a high volume. Hearing experts advise against continuous extended play.

If you experience a ringing in your ears, reduce volume or discontinue use.

Do not use while operating a motorized vehicle. It may create a traffic hazard and is illegal in many areas.

You should use extreme caution or temporarily discontinue use in potentially hazardous situations:

Even if your headphones or earphones is an open-air type designed to let you hear outside sounds, don't turn up the volume so high that you can't hear what's around you.

Sound can be deceiving. Over time your hearing "comfort level" adapts to higher volumes of sound. So what sounds "normal" can actually be loud and harmful to your hearing.

Guard against this by setting your equipment at a safe level BEFORE your hearing adapts.

To establish a safe level:

- Start your volume control at a low setting.
- Slowly increase the sound until you can hear it comfortably and clearly, and without distortion.

Once you have established a comfortable sound level:

- Set the dial and leave it there.

### Rechargeable batteries

- Only the RP-BP60, P-3GAVA/2B, SH-CDB8D batteries can be recharged.
- If the power delivered by the batteries lasts for a very short time after recharging, it means that the batteries' service life is over. Do not use them any more.
- Recharging already charged batteries will shorten their service life.
- When recharging batteries for the first time or when they have not been used for a long period of time, the play time may be shorter than usual. In a case like this, repeatedly recharge and discharge the batteries. This will restore them to their regular state.
- Do not allow any metal objects to touch the terminals of rechargeable batteries since this may cause short-circuiting which is dangerous.
- Do not peel off the plastic covering on the rechargeable batteries. Short-circuiting may occur which is dangerous.

### Dry cell batteries/rechargeable batteries

To prevent damage to the batteries and electrolyte leakage, heed the following points.

- Align the ⊕ and ⊖ polarities properly when inserting the batteries.
- Do not mix different types or makes of batteries or old and new batteries.
- Remove the batteries if you do not plan to use the unit for a long period of time.
- Do not throw batteries into a fire, and do not short-circuit, disassemble or subject them to excessive heat.
- Do not attempt to recharge dry cell batteries.

### Carrying dry cell batteries/rechargeable batteries around

When putting dry cell or rechargeable batteries in a pocket or bag, ensure that no other metal objects such as a necklace are placed together with them. Contact with metal may cause short-circuiting which, in turn, may cause a fire.

Be absolutely sure to carry the rechargeable batteries in the battery carrying case.

### When purchasing rechargeable batteries

As a safety precaution, the portable CD players made by Panasonic have a construction designed to make it impossible to recharge ordinary batteries.

To use rechargeable batteries, be absolutely sure to purchase the rechargeable Ni-Cd batteries designed especially for this unit.

**Special rechargeable Ni-Cd batteries:  
P-3GAVA/2B, SH-CDB8D (set of 2)**

For details, check with your dealer.

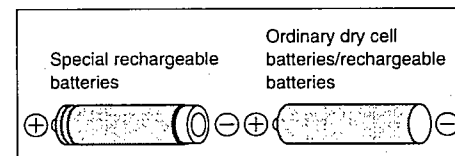

### When driving a car

In the interest of traffic safety, do not operate the unit while driving.



## ■ Handling Precautions for Traverse Deck

The laser diode in the traverse deck (optical pickup) may break down due to potential difference caused by static electricity of clothes or human body.

So, be careful of electrostatic breakdown during repair of the traverse deck (optical pickup).

### ● Handling of traverse deck (optical pickup)

1. Do not subject the traverse deck (optical pickup) to static electricity as it is extremely sensitive to electrical shock.
2. To protect the laser diode against electrostatic breakdown, short the flexible board (FFC board) with a clip or similar object.
3. Take care not to apply excessive stress to the flexible board (FFC board).
4. Do not turn the variable resistor (laser power adjustment). It has already been adjusted.

### ● Grounding for electrostatic breakdown prevention

1. Human body grounding  
Use the anti-static wrist strap to discharge the static electricity from your body.
2. Work table grounding  
Put a conductive material (sheet) or steel sheet on the area where the traverse deck (optical pickup) is placed, and ground the sheet.

#### Caution:

The static electricity of your clothes will not be grounded through the wrist strap. So, take care not to let your clothes touch the traverse deck (optical pickup).

#### Caution when Replacing the Traverse Deck:

The traverse deck has a short point shorted with solder to protect the laser diode against electrostatic breakdown. Be sure to remove the solder from the short point before making connections.

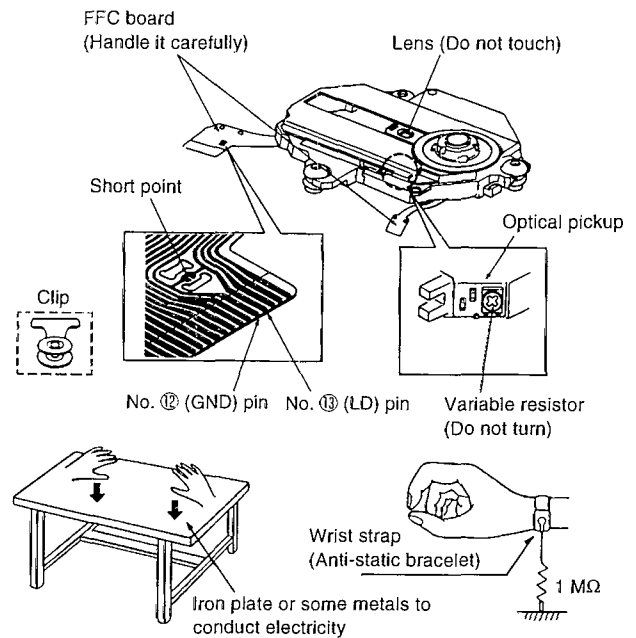

## ■ Outline of 10 - Second Sound Keeper Technique Used for Prevention of Sound from Skipping

### 1. Conventional Shockproofing Technique

Input information read out of the CD at double speed is demodulated, stored in the memory, and while sound-marking signal is supplied at normal speed from the memory to the D/A converter, the residual data is accumulated in the memory.

If reaccess to the break point is accomplished before the memory becomes empty, apparent playback sound is entirely kept free from breaking even when information pauses due to vibration, etc. It was necessary to use the 4M bits memory for securing the accumulation time of about 10 seconds.

The data compression technique has conducted to reduction of required memory capacity from 4M bits to 1M bit for securing the accumulation time equivalent to the conventional.

### 2. Compression-shockproofing [Outline]

Fig. 1 is a block diagram showing the compression-shockproofing mechanism, the difference of which from the conventional mechanism is as follows: Input information read out at double speed undergoes data compression (16 bits → 4 bits) by the encoder in the ADPCM (Adaptive Difference PCM) and stored in the external memory; the stored memory information undergoes data elongation (4 bits → 16 bits) by the decoder in the ADPCM and supplied at the normal speed to the D/A converter

#### All-inclusive Block Diagram

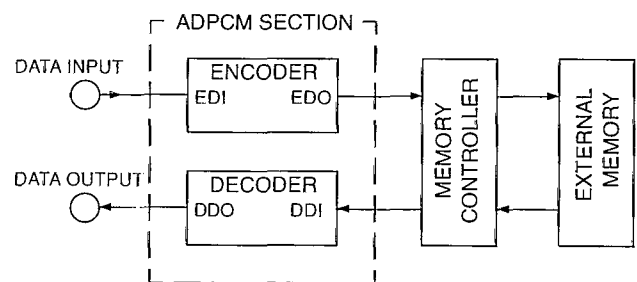

# Operation Checks and Component Replacement Procedures

- NOTE**
1. This section describes procedures for checking the operation of the major printed circuit boards and replacing the main components.
  2. For reassembly after operation checks or replacement, reverse the respective procedures. Special reassembly procedures are described only when required.
  3. [ ] indicates parts No.

## 1. Checking for the P.C.B.

〈Checking for the P.C.B. (A side)〉

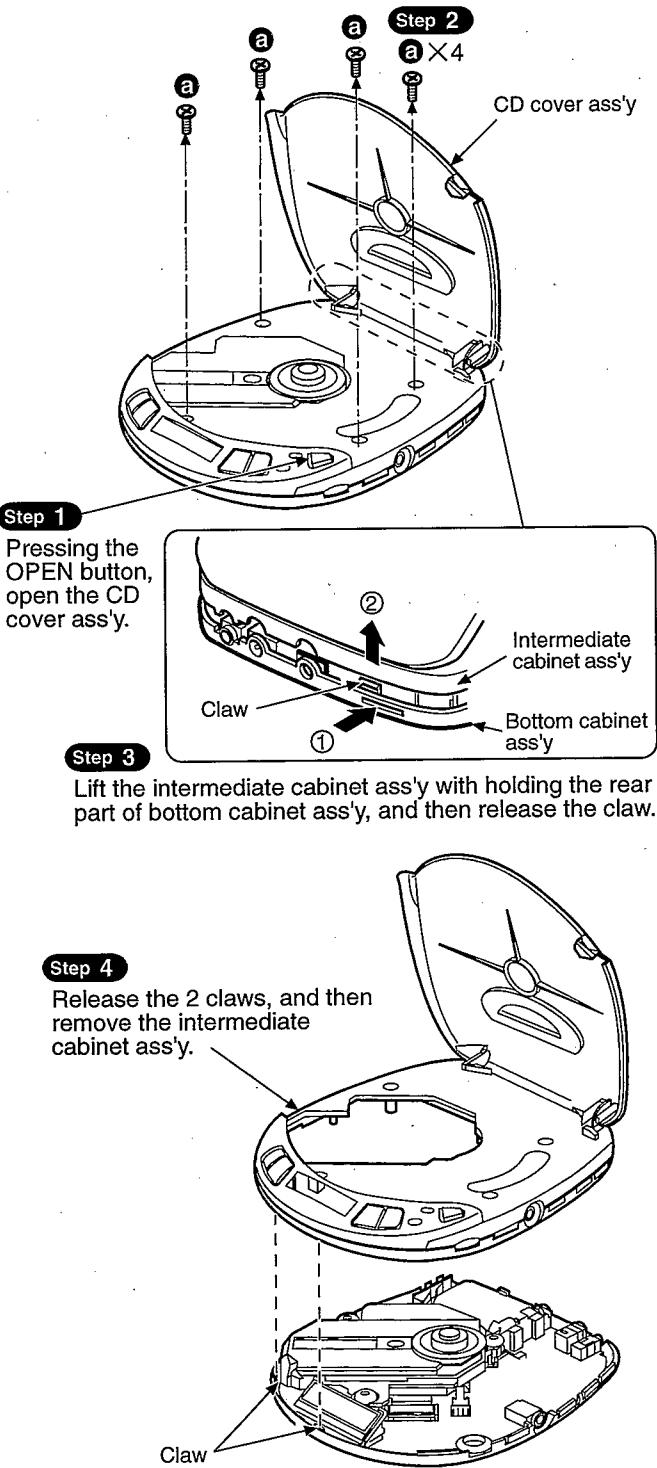

## NOTE

- After checking, unsolder the short land to open circuit.
- The tip of screw must not protrude above the floating rubber.
- To keep insulation, place the insulator sheet (paper etc.) between the P.C.B. and the head of screws.

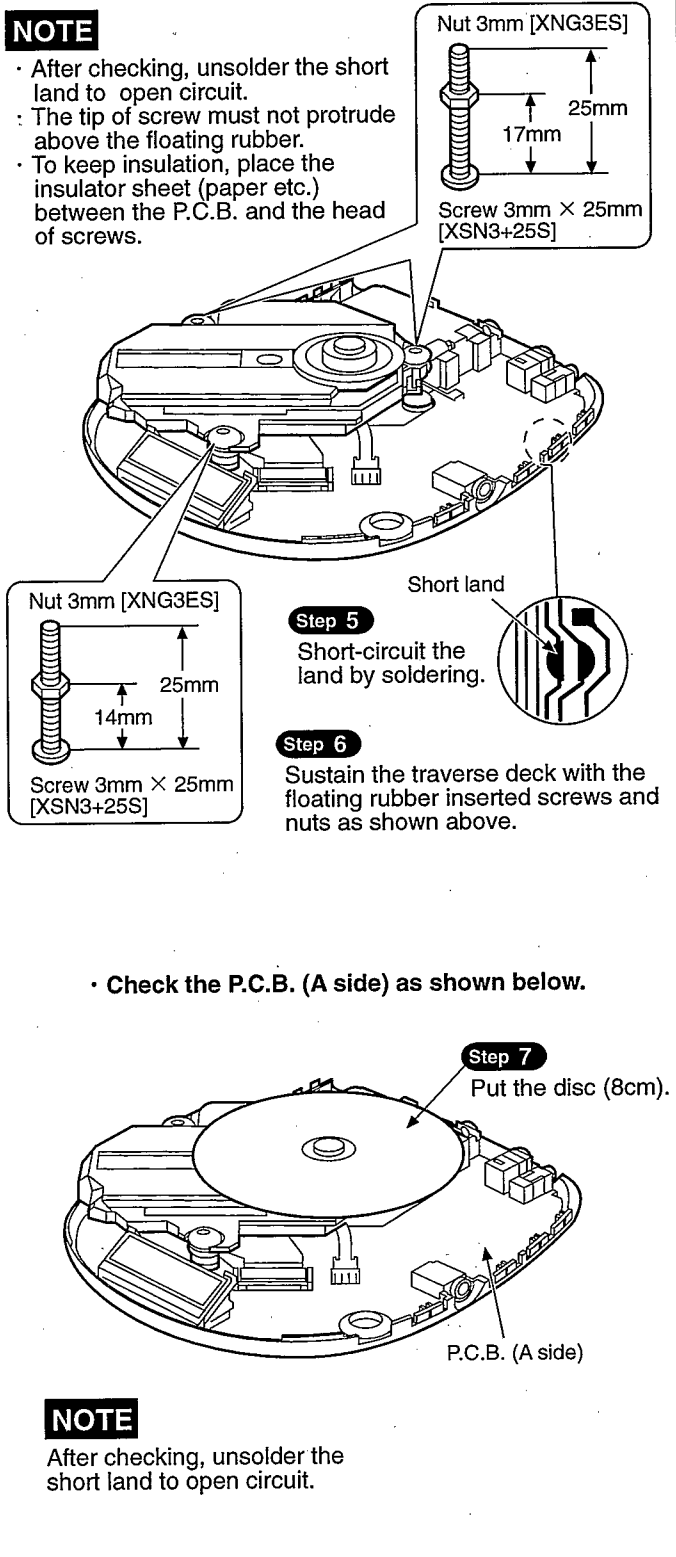

## NOTE

After checking, unsolder the short land to open circuit.

〈Checking for the P.C.B. (B side)〉

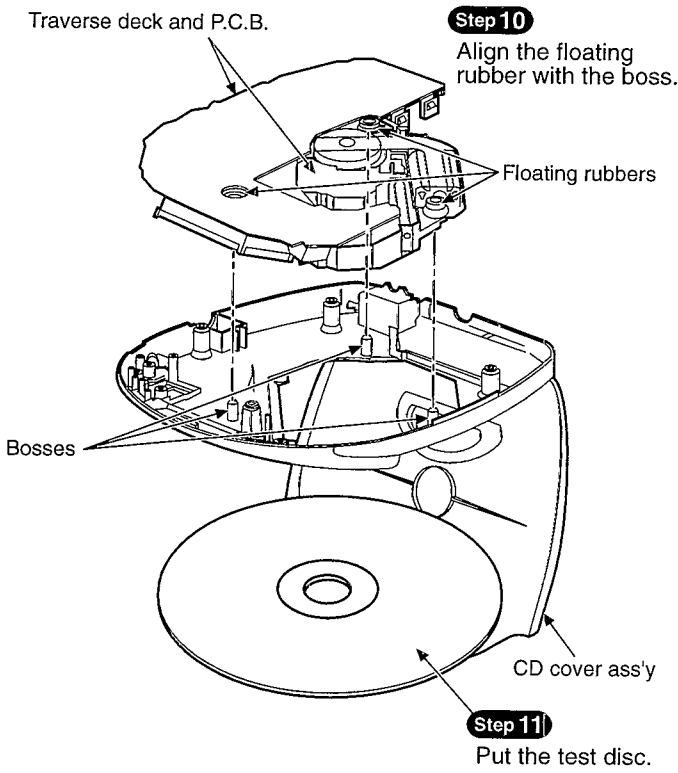
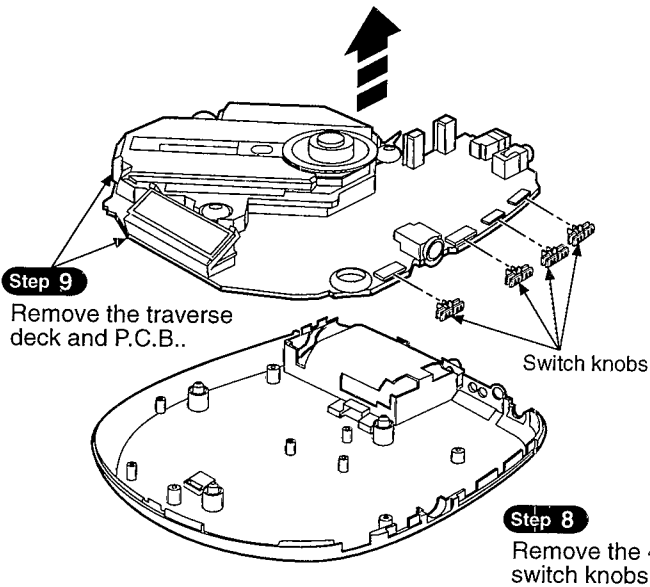

• Check the P.C.B. (B side) as shown below.

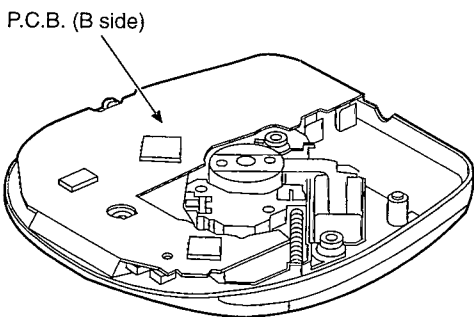

**NOTE**

After checking, unsolder the short land to open circuit.

**Notice for installation of switch knobs**

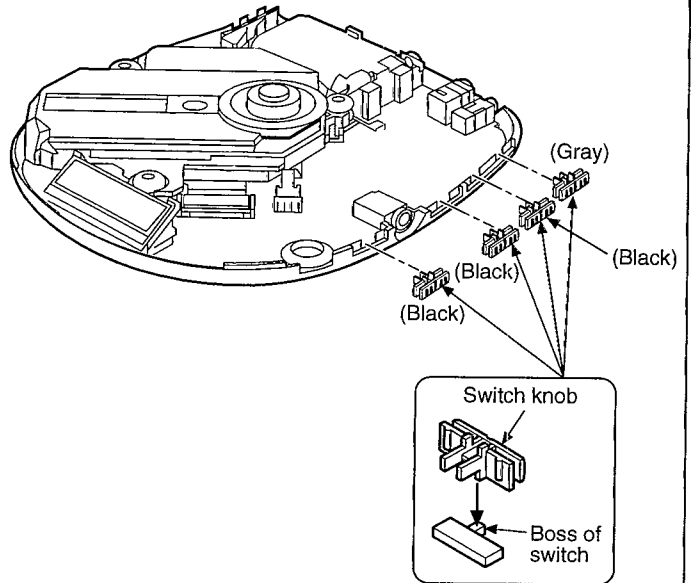

**2. Replacement for the traverse deck**

• Follow the **Step 1.** ~ **Step 4** in item 1 on page 8.

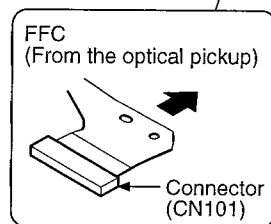
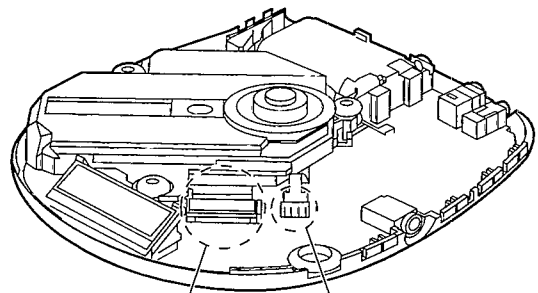

**Step 1**

Pull out the FFC from connector (CN101).

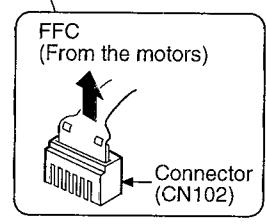

**Step 2**

Pull out the FFC from connector (CN102).

**NOTE**

Solder the point between pin ⑫ (LD GND) and pin ⑬ (LD) of FFC board.  
(Refer to "Handling Precautions for Traverse Deck" on page 7.)

### 3. Replacement for the CD cover ass'y

Follow the **Step 1** ~ **Step 4** in item 1 on page 8.

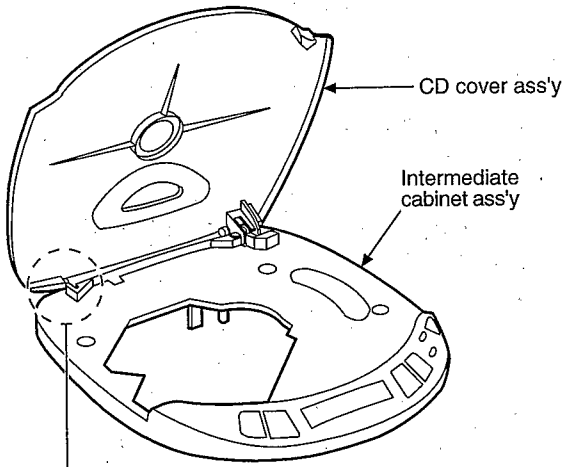

#### Step 1

Push the rid in the direction of arrow with thin tip of minus screwdriver, and then remove the CD cover ass'y.

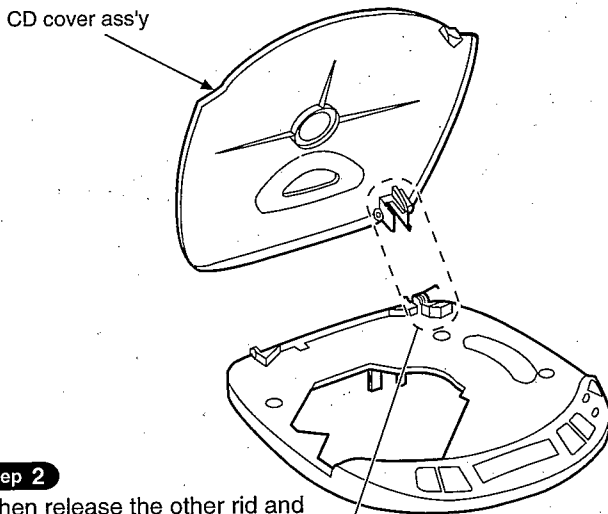
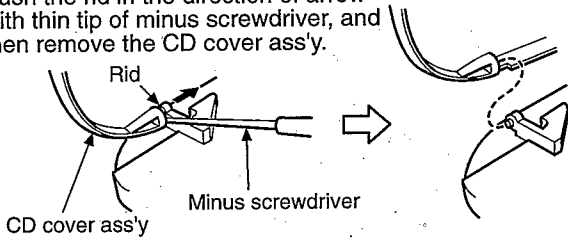

#### Step 2

Then release the other rid and remove the CD cover ass'y.

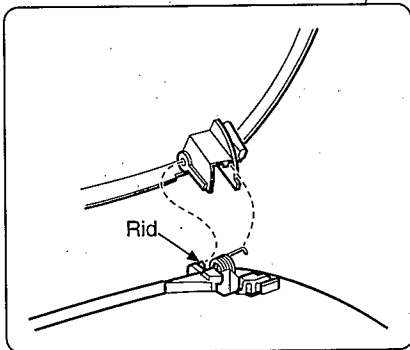

## ■ Checking the Operation Problems on the Traverse Deck (Optical Pickup)

Make sure to follow the procedures below to check the operation problems of the traverse deck (optical pickup) before replacing it. Replace the traverse deck only after the problem is identified.

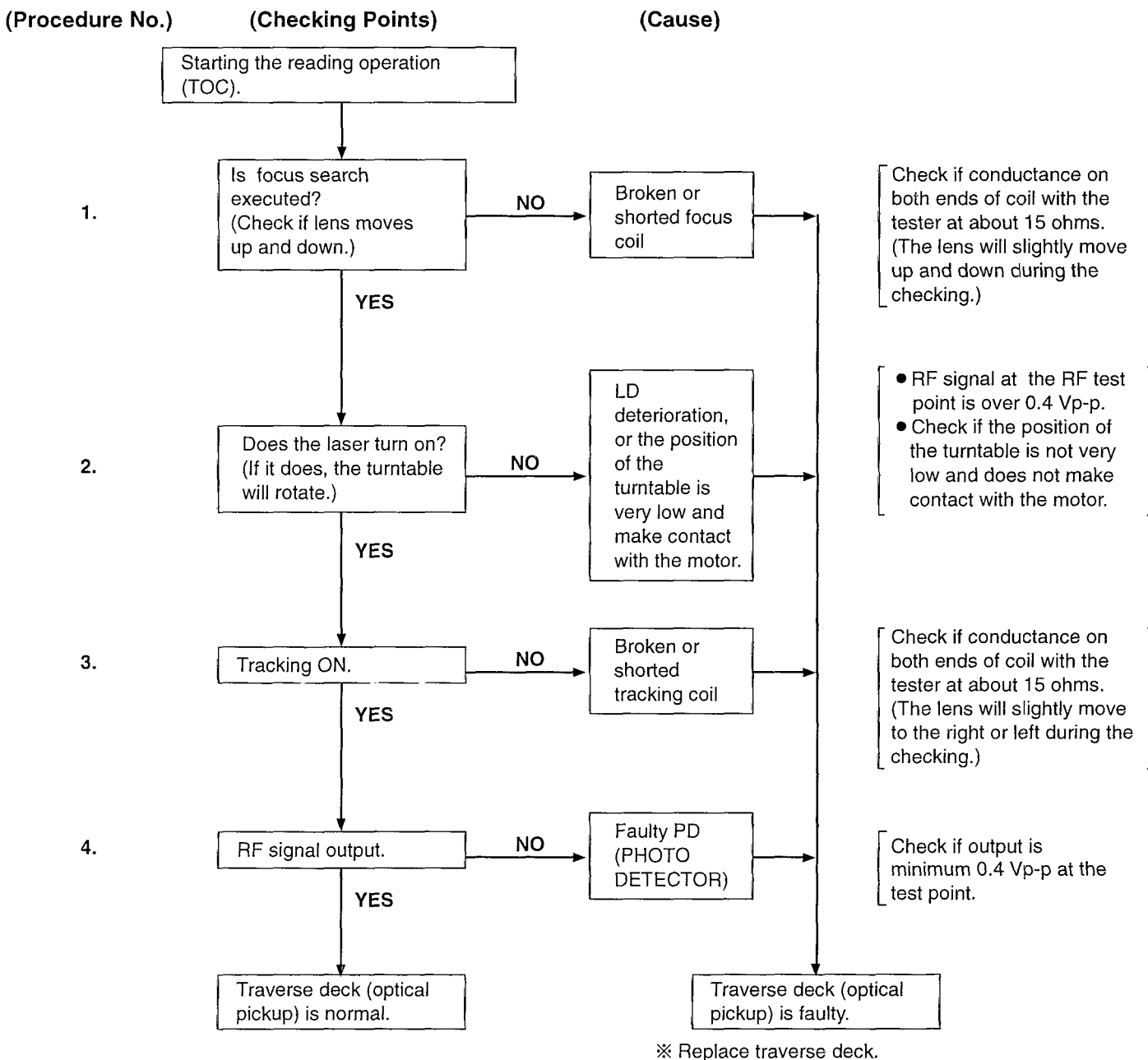

- Check electrical circuit.
- Check for flaws on disc or if it is wrapped or not centered.
- Check the operations described below on the traverse deck after replacing it.

\* Checking Skip Search

1. Play an ordinary musical program disc.
2. Press the skip button to check for normal skip search operation (in both the forward and reverse directions).

\* Checking Manual Search

1. Play an ordinary musical program disc.
2. Press the manual search button to check for smooth manual search operations at either low or high speed (in both the forward and reverse directions).

\* Checking Playability

1. Play the 0.7 mm black dot and the 0.7 mm wedge on the playability test disc (SZZP1054C) and verify that no sound skip or noise occurs.
2. Play the middle tracks of the uneven test disc (SZZP1056C) and verify that no sound skip or noise occurs.

## Automatic Adjustment Results Display Function (Self-check Function)

On the unit (SL-S230), each automatic adjustment result are displayed on the LCD. This function is convenient to check or identify which automatic adjustment circuit is incorrect. The followings are the contents of the automatic adjustment result displays (self-check function).

### How to display automatic adjustment results

1. Load the test disc (SZZP1054C).
2. Press the ◀◀ (SKIP/SEARCH) and ▶▶ (SKIP/SEARCH) Buttons simultaneously and hold them, and additionally press the ▶/|| (PLAY/PAUSE) Button.
3. Press the ■ (STOP/POWER OFF) Button once.
4. An automatic adjustment result is displayed on the LCD.

### Display of automatic adjustment results (self-check function)

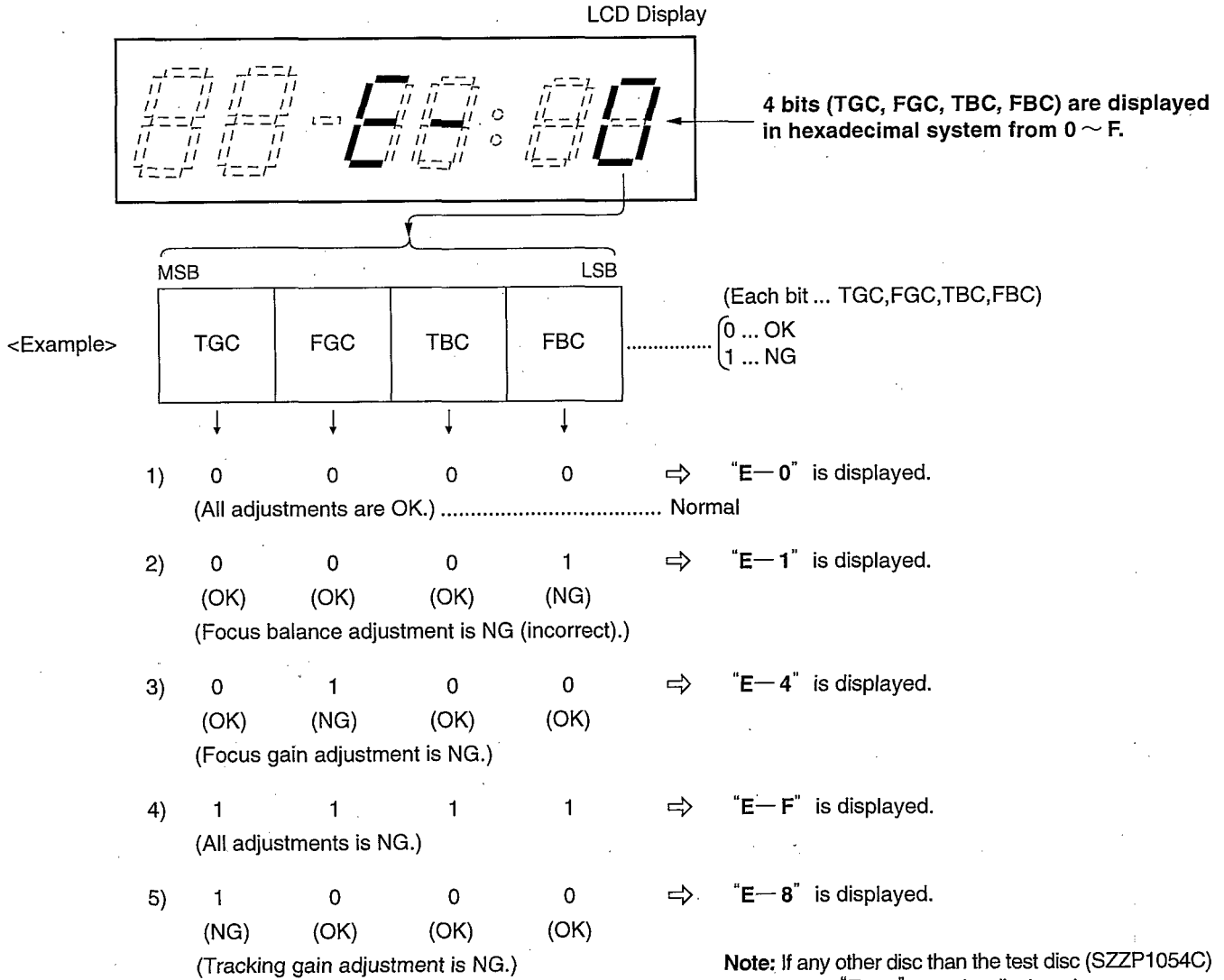

**Note:** If any other disc than the test disc (SZZP1054C) is used, an “E-8” may be displayed.

<Example> **Follow the below steps when "E-1" is displayed.**

(Cause: Focus balance (FBC) is set beyond the limit.)

- Check if
  - (1) the waveform or voltage of the focus servo circuit is correct, and
  - (2) the optical pickup returns to the normal state by exchanging the traverse deck.

**Follow the below steps when "E-4" is displayed.**

(Cause: Focus gain (FGC) is set beyond the limit.)

- Check if
  - (1) the waveform or voltage of the focus servo circuit is correct,
  - (2) the focus coil of the optical pickup is correct (around 15 ohms), and
  - (3) the optical pickup returns to the normal state by exchanging the traverse deck.

**Follow the below steps when "E-F" is displayed.**

(Cause: All adjustments (TGC,FGC,TBC,FBC) are set beyond the limit.)

- Check if
  - (1) the optical pickup returns to the normal state by exchanging the traverse deck, and
  - (2) the waveform or voltage of the servo IC's(IC101,501) are correct.

**Note:**

It is not always necessary to exchange the traverse deck when an error message is displayed. Be sure to check if the circuit is defective or not before exchanging the traverse deck.

**Note:**

If any other disc than the test disc (SZZP1054C) is used, an error message may be displayed. This is not a malfunction.

## ■ Measurements and Adjustments

**Warning:** This product uses a laser diode. Refer to caution statements on frontcover.

### ● Measuring instruments and special tools

- |  |  |
|--|--|
| <ul style="list-style-type: none"> <li>● <b>Test discs</b> <ol style="list-style-type: none"> <li>1. Playability test disc (SZZP1054C)</li> <li>2. Uneven test disc (SZZP1056C)</li> </ol> </li> </ul> | <ul style="list-style-type: none"> <li>● Musical program disc (ordinary)</li> <li>● DC voltmeter</li> <li>● Lead wire (for test points)</li> </ul> |
|--|--|

### ● Test short land

Short-circuit the lands of the laser ON/OFF switch (S201) by soldering them. It turns "ON" position. (Refer to below Fig. 1. or printed circuit board and wiring connection diagram for short land location on page 26.)

**Note:** Remove the solders from the lands after adjustment.

### ● Adjustment point

- Notes:** 1. Please refer to the printed circuit board and wiring connection diagram for test point locations.  
2. Take care to connect CN101 (as shown in Fig.1).

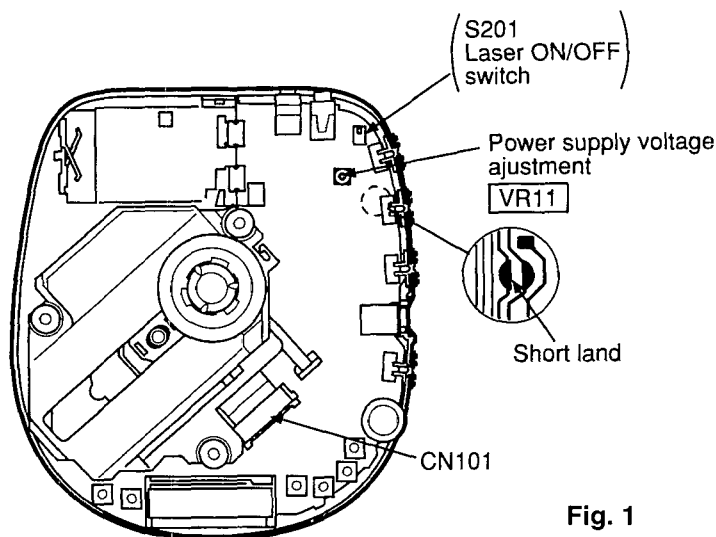

Fig. 1

• Adjustment procedure

**(1) POWER SUPPLY VOLTAGE ADJUSTMENT**

- |   |  |
|---|--|
| <ol style="list-style-type: none"> <li>1. Connect the DC voltmeter to <b>TP103</b> (VCC) (+) and <b>TP104</b> (GND) on the P.C.B.</li> <li>2. Connect the AC adaptor cord to the DC (IN) port and move the PLAY switch to the ON position. Anti-shock is set in OFF position. (Use a new dry cell battery or a rechargeable battery that is full charged.)</li> </ol> | <ol style="list-style-type: none"> <li>3. Insert the test disc, and switch the player power ON.</li> <li>4. Adjust <b>VR11</b> on the P.C.B. at <math>2.50 \pm 0.02V</math>, as shown in Fig.1.</li> </ol> |
|---|--|

**(2) CHECK OF PLAY OPERATION**

- |   |   |
|---|---|
| <p><b>* Checking Skip Search</b></p> <ol style="list-style-type: none"> <li>1. Play an ordinary musical program disc.</li> <li>2. Press the skip button to check for normal skip search operation (in both the forward and backward directions).</li> </ol> <p><b>* Checking Manual Search</b></p> <ol style="list-style-type: none"> <li>1. Play an ordinary musical program disc.</li> <li>2. Press the manual search button to check for smooth manual search operations at either low or high speed (in both the forward and backward directions).</li> </ol> | <p><b>* Checking Playability</b></p> <ol style="list-style-type: none"> <li>1. Play the 0.7 mm black dot and the 0.7 mm wedge on the playability test disc (SZZP1054C) and verify that no sound skip or noise occurs.</li> <li>2. Play the middle tracks of the uneven test disc (SZZ1056C) and verify that no sound skip or noise occurs.</li> </ol> |
|---|---|

• Automatic adjustment

On our conventional type portable CD player, there were mounted 6 semi-fixed controls for each adjustment. Since the SL-S230 servo circuit is equipped with an automatic adjusting circuit, these controls are removed from SL-S230.

On conventional portable CD player Use for Old Servo IC (AN8373SE2, AN8374SE2)	➔	On SL-S230 Use for New Servo IC (AN8339NSBE1, MN662780RPS2)
1. Tracking Offset Adjustment VR (TOC) <input type="checkbox"/>	➔	Non Adjustment
2. Focus Offset Adjustment VR (FOC) <input type="checkbox"/>	➔	Non Adjustment
3. Tracking Gain Adjustment VR (TGC) <input type="checkbox"/>	➔	Automatic Adjusting Circuit
4. Focus Gain Adjustment VR (FGC) <input type="checkbox"/>	➔	Automatic Adjusting Circuit
5. Tracking Balance Adjustment VR (TBC) <input type="checkbox"/>	➔	Automatic Adjusting Circuit
6. Focus Balance Adjustment VR (FBC) <input type="checkbox"/>	➔	Automatic Adjusting Circuit
Total 6 Adjustment VRs	➔	No Adjustment VR



Although all discs are manufactured according to the same specifications, their characteristics are not always precisely the same because they are produced by different manufacturers in various lots, or have different warp etc. SL-S230 automatically controls the servo circuit to obtain optimum performance according to any disc's characteristics. Therefore, no malfunction occurs because of mis-adjustment.



## ■ Schematic Diagram

(This schematic diagram may be modified at any time with the development of new technology.)

### Notes:

- S201 : Laser ON/OFF switch in "OFF" position.  
(It turns "ON" with disc holder closed.)
  - S202 : Rest detector in "OFF" position.  
(It turns "ON" when optical pickup comes to innermost periphery.)
  - S301 : Memory/recall (MEMORY/RECALL) switch.
  - S302 : Repeat (REPEAT) switch.
  - S303, 304: Skip/search (|◀◀ -SKIP/--SEARCH ▶▶|) switches.  
(S303:|◀◀ ,S304:▶▶|)
  - S305 : Stop/power off (■ POWER OFF) switch.
  - S306 : Play/pause (▶ ||) switch.
  - S307 : Play mode selector (MODE) in "RESUME" position.  
(RANDOM ↔ NORMAL ↔ RESUME)
  - S308 : Hold (HOLD) switch in "OFF" position.
  - S501 : Anti-shock (ANTI-SHOCK) switch in "OFF" position.
  - S701 : XBS Selector (XBS) switch in "OFF" position.
  - VR11 : Power supply voltage adjustment VR.
  - VR701-1, VR701-2 : Volume control VR.
- The voltage value and waveforms are the reference voltage of this measured by DC electronic voltmeter (high impedance) and oscilloscope on the basis of GND terminal (DC IN Jack). Accordingly, there may arise some errors in the voltage values and waveforms depending upon the internal impedance of the tester or measuring unit.
  - The parenthesized is the voltage for test disc (1kHz, L+R, 0 dB) in play mode, and the other, for no disc in stop mode.
  - AC adaptor is used for power supply.
  -  : Positive voltage lines.
  -  : Audio signal lines.
  - Important safety notice:  
Components identified by  $\Delta$  mark have special characteristics important for safety. Furthermore, special parts which have purposes of fire-retardant (resistors), high-quality sound (capacitors), low-noise (resistors), etc. are used. When replacing any of components, be sure to use only manufacture's specified parts shown in the parts list.

### Caution!

- IC and LSI are sensitive to static electricity.  
Secondary trouble can be prevented by taking care during repair.
- Cover the parts boxes made of plastics with aluminum foil.
  - Ground the soldering iron.
  - Put a conductive mat on the work table.
  - Do not touch the pins of IC or LSI with fingers directly.

## ■ Type Illustration of IC's, Transistor and Diodes

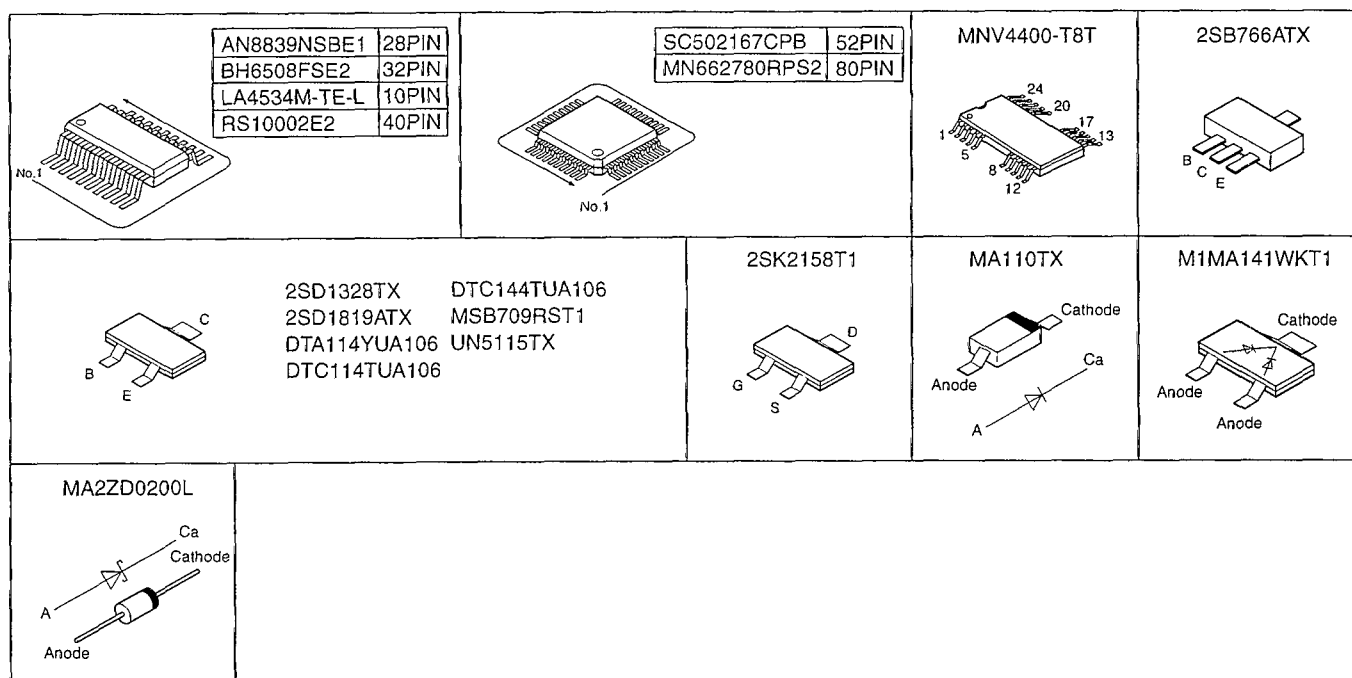

— : Positive voltage lines.    ⇨ : Audio signal lines.

(P.C.Board: on pages 26,27)

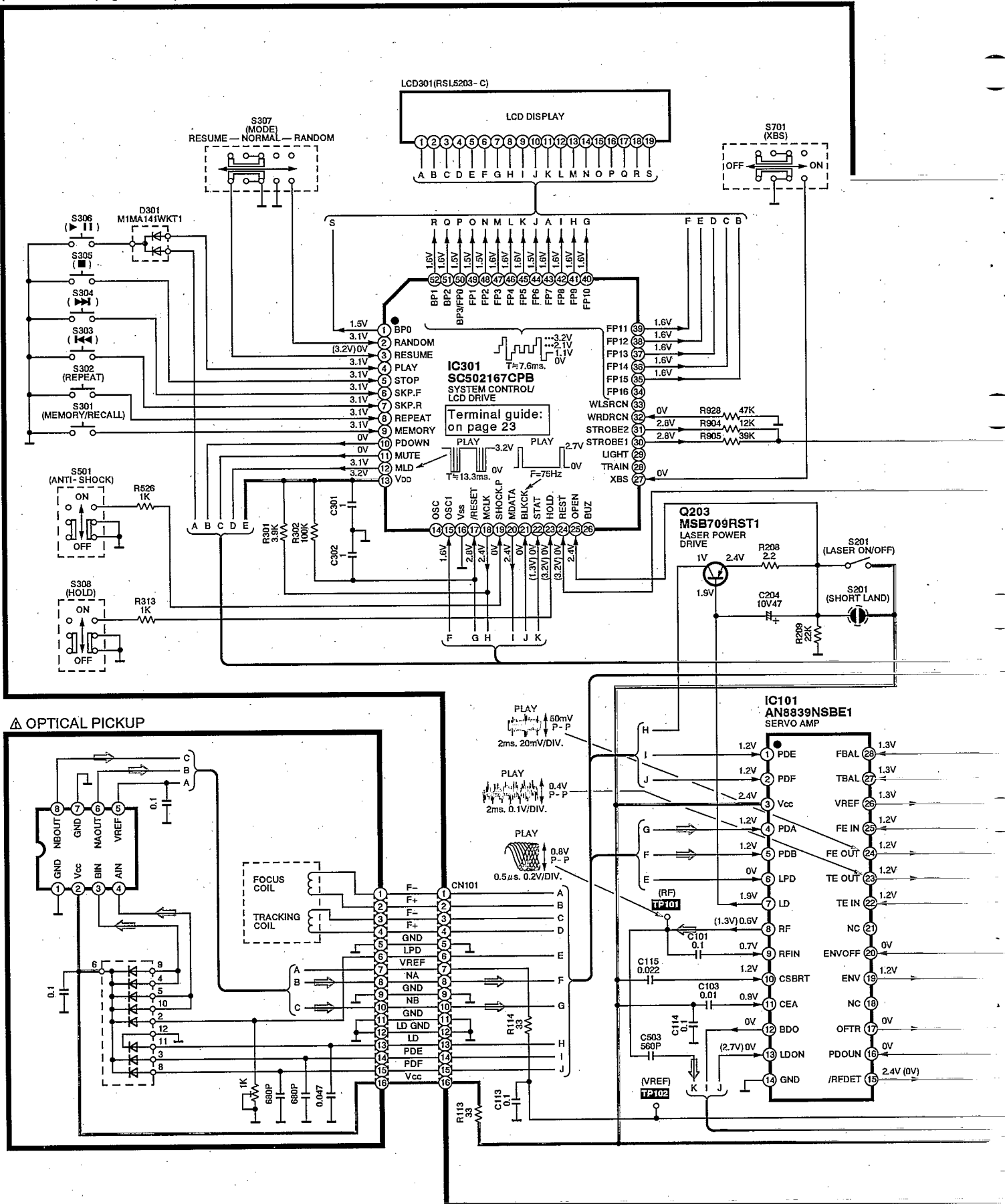

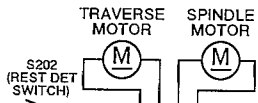

TRVERSE MOTOR  
SPINDLE MOTOR

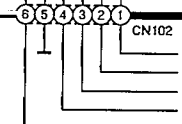

R916  
82K

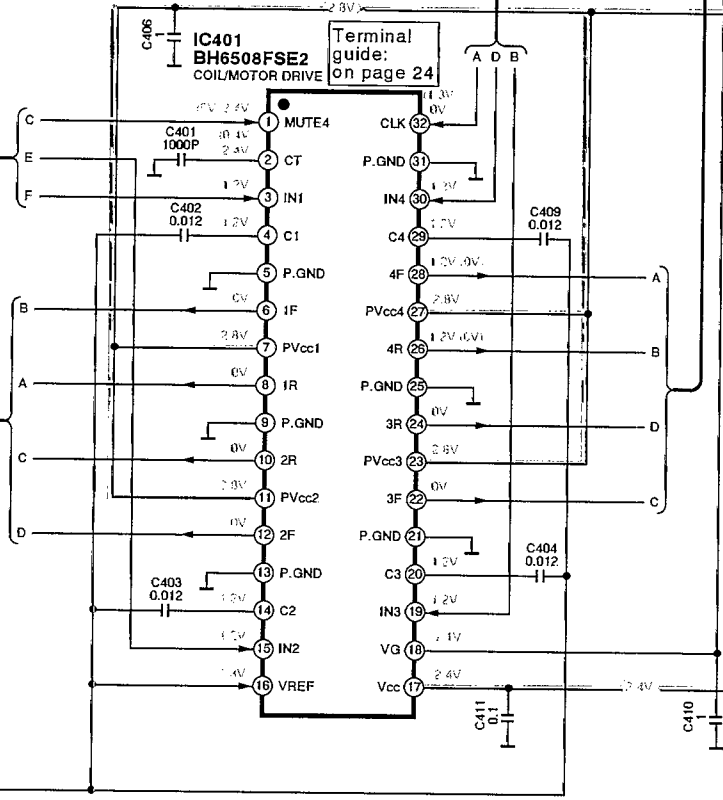

Terminal guide:  
on page 24

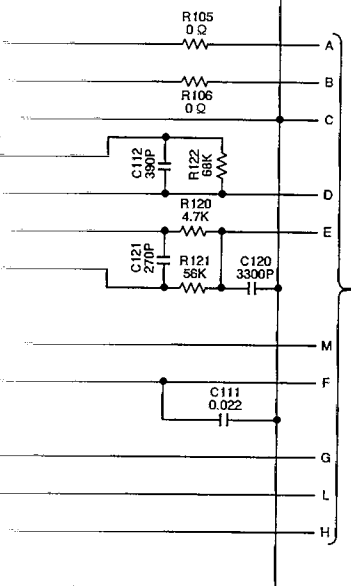

IC503  
MNV4400-T8T  
4M DRAM  
Terminal guide:  
on page 22

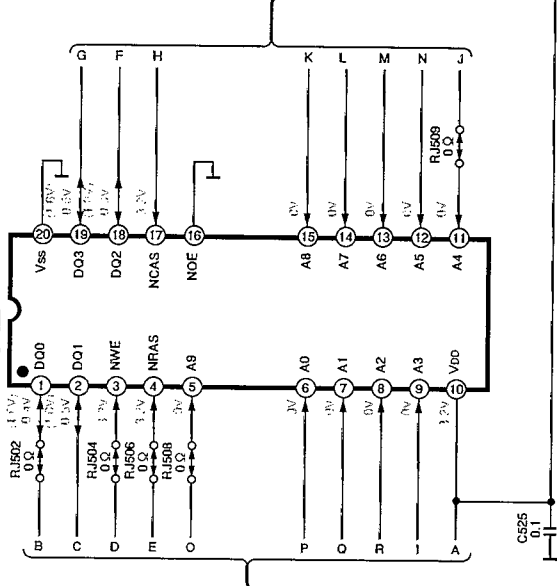

— : Positive voltage lines.    ⇨ : Audio signal lines.

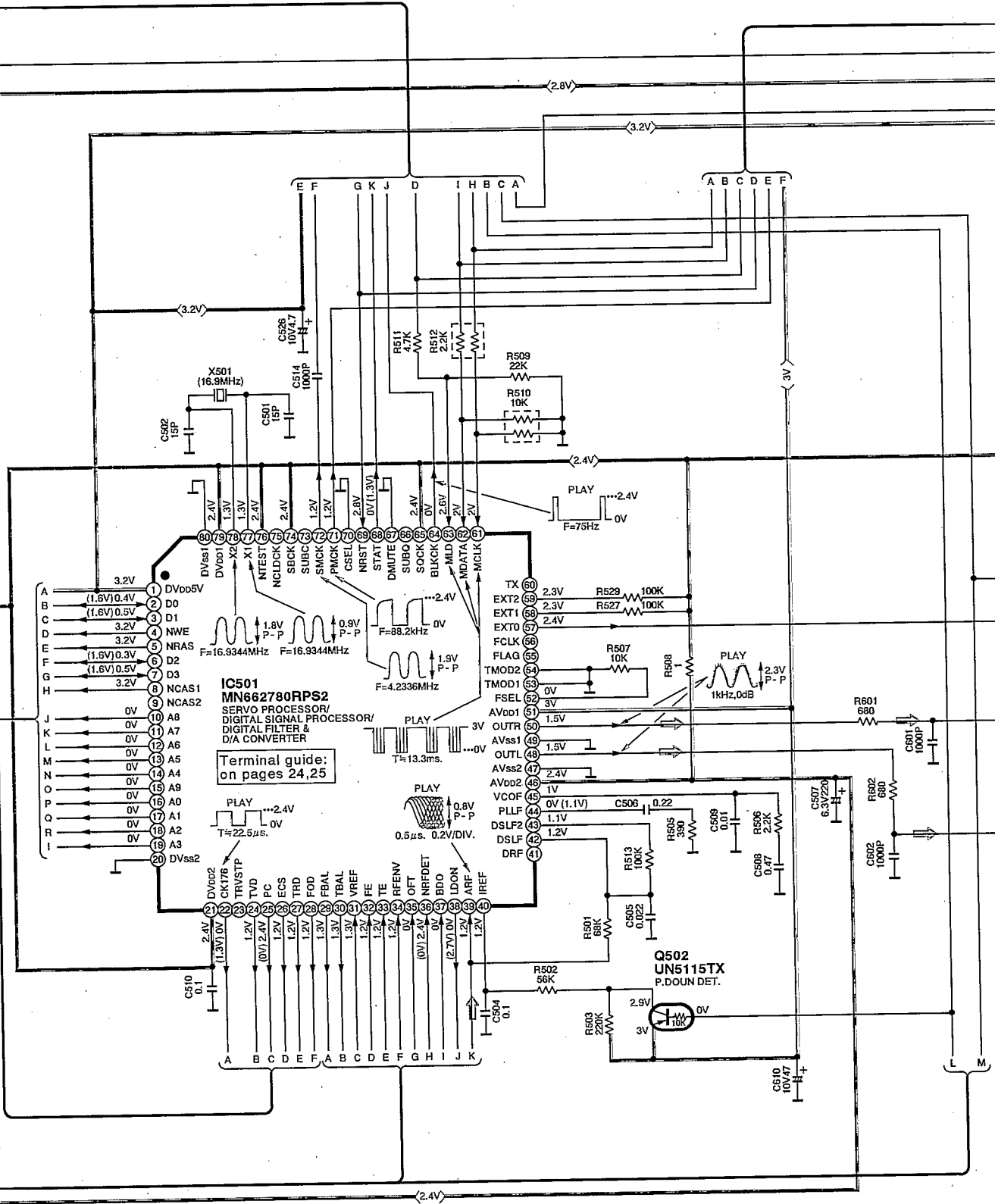

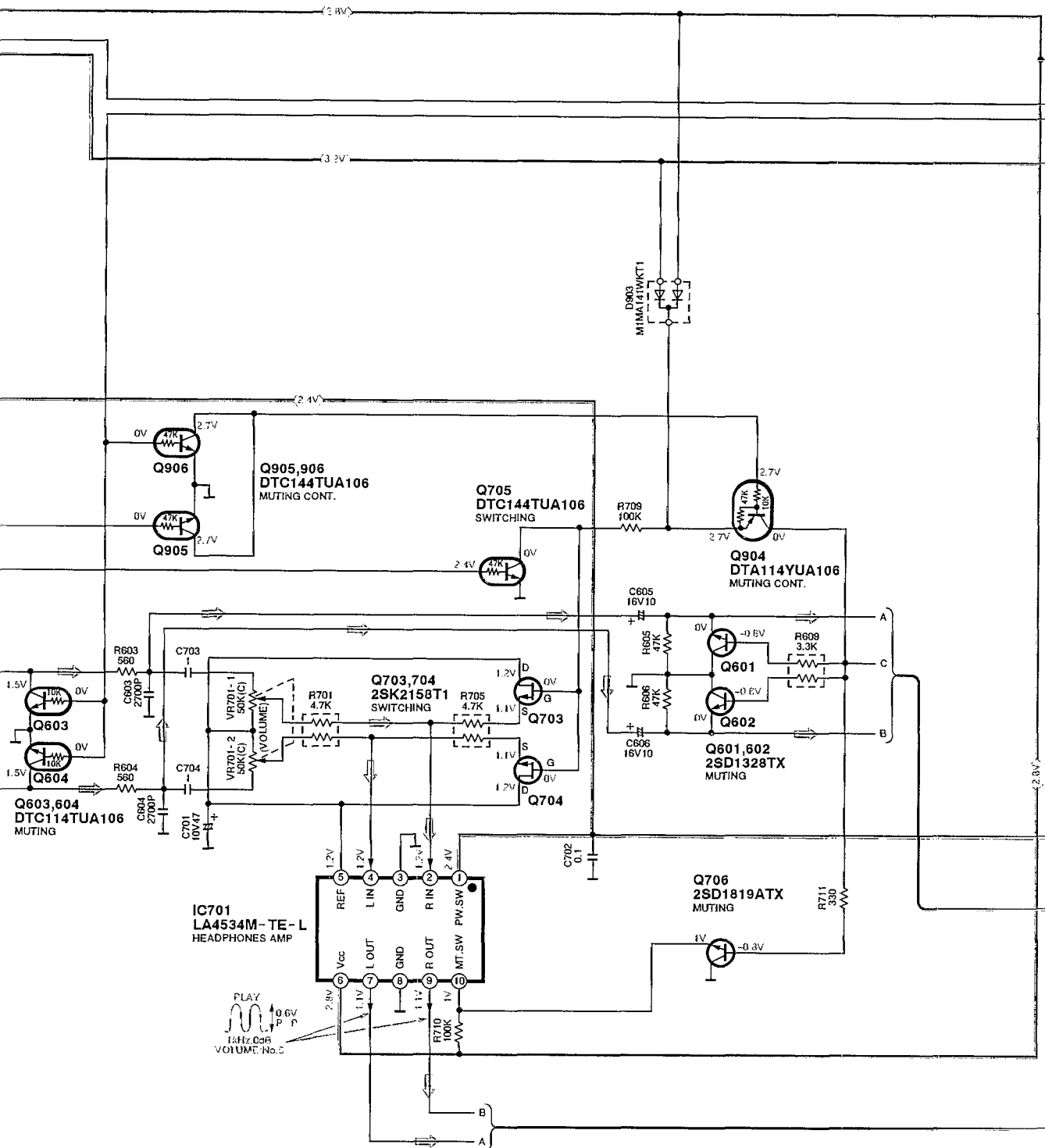

— : Positive voltage lines.    ⇨ : Audio signal lines.

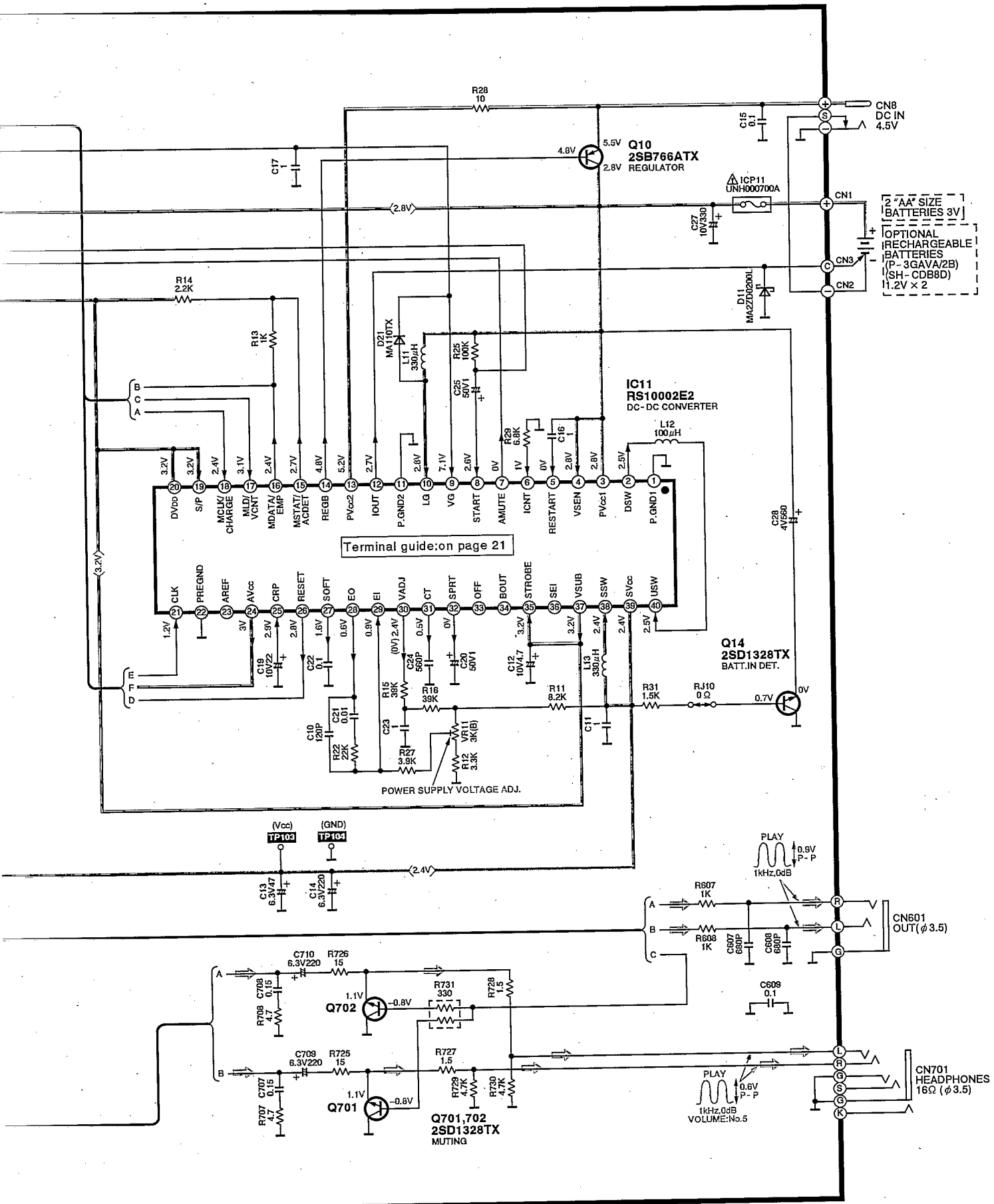

## ■ Terminal Function of IC's

### ● IC11 (RS10002E2): DC-DC Converter

Pin No.	Terminal Name	I/O	Function
1	PGND1	-	GND terminal
2	DSW	O	DC/DC converter coil drive terminal
3	PVCC1	I	Power supply terminal
4	VSEN	I	Empty supply terminal (Power supply terminal)
5	RESTART	I	DC/DC converter drive terminal
6	ICNT	I	Charge current setting terminal
7	AMUTE	O	Muting signal output terminal
8	START	I	DC/DC converter start terminal
9	VG	I	Power supply terminal
10	LG	I	Connected to power supply
11	PGND2	-	GND terminal
12	IOUT	O	Charge signal output terminal
13	PVCC2	I	Power supply terminal
14	PEGB	O	Regulator drive signal output terminal
15	MSTAT/ AC DET	O	DC jack detect signal output terminal
16	M DATA/ EMP	O	Decline voltage detect output terminal
17	MLD/VCNT	I	Regulator voltage select input terminal
18	MCLK/ CHARGE	I	Charge ON/OFF terminal
19	S/P	I	Serial/Parallel select terminal (Connected power supply)
20	DVDD	I	Power supply terminal

Pin No.	Terminal Name	I/O	Function
21	CLK	I	Clock signal input terminal
22	PREGND	-	GND terminal
23	AREF	O	Audio reference output terminal
24	AVCC	O	Ripple filter output terminal
25	CRP	I	Connected to capacitor
26	RESET	O	Reser detect signal output terminal
27	SOFT	O	Soft start setting terminal (Connected to capacitor)
28	EO	O	DC/DC converter error amp output terminal
29	EI	I	DC/DC converter error amp input terminal
30	VADJ	O	DC/DC converter variable output terminal
31	CT	O	Triangular wave output terminal (Connected to capacitor)
32	SPRT	O	Power off time-constat setting terminal (Connected to capacitor)
33	OFF	I	DC/DC converter off terminal (Not used, open)
34	BOUT	O	Amp output terminal
35	STROBE	I	Strobe input terminal
36	SEI	I	Sub DC/DC converter, error amp input terminal (Not used, open)
37	VSUB	I	Power supply terminal
38	SSW		
39	SVCC		
40	USW	I	DC/DC converter coil drive terminal

## ● IC101 (AN8839NSBE1): Servo Amp

Pin No.	Terminal Name	I/O	Function
1	PDE	I	Tracking signal input terminal (1)
2	PDF	I	Tracking signal input terminal (2)
3	Vcc	I	Power supply terminal
4	PDA	I	Focus signal input terminal (1)
5	PDB	I	Focus signal input terminal (2)
6	LPD	I	APC amp input terminal
7	LD	O	APC amp output terminal
8	RF	O	RF summing output terminal
9	RF IN	I	RF signal input terminal
10	CSBRT	I	Capacitor connection terminal for OFTR
11	CEA	I	Capacitor connection terminal for H.P.F. amp
12	BDO	O	Dropout signal output terminal ("H" : Dropout)
13	LDON	I	APC control input terminal
14	GND	-	GND terminal

Pin No.	Terminal Name	I/O	Function
15	/RFDET	O	RF det. signal output terminal ("L" : Det.)
16	PDOWN	O	Power down input terminal
17	OFTR	O	Off track signal output terminal ("H" : Off track)
18	NC	-	Not used, open
19	ENV	O	RF envelope signal output terminal
20	ENV OFF	I	ENV control input terminal
21	NC	-	Not used, open
22	TE IN	I	Tracking error amp input terminal
23	TE OUT	O	Tracking error amp output terminal
24	FE OUT	O	Focus error amp output terminal
25	FE IN	I	Focus error amp input terminal
26	VREF	O	Reference voltage output terminal
27	TBAL	I	Tracking balance signal input terminal
28	FBAL	I	Focus balance signal input terminal

## ● IC503 (MNV4400-T8T): 4M DRAM

Pin No.	Terminal Name	I/O	Function
1	DQ0	I/O	Data 0 input/output terminal
2	DQ1	I/O	Data 1 input/output terminal
3	NWE	I	Write enable terminal
4	NRAS	I	Row address strobe input terminal
5	A9	I	Address 9 input terminal
6	A0	I	Address 0 input terminal
7 } 9	A1 } A3	I	Address 1~3 input terminal

Pin No.	Terminal Name	I/O	Function
10	VCC	I	Power supply terminal
11 } 15	A4 } A8	I	Address 4~8 output terminal
16	NOE	I	Output enable terminal
17	NCAS	I	Column address strobe terminal
18	DQ2	I/O	Data 2 input/output terminal
19	DQ3	I/O	Data 3 input/output terminal
20	VSS	-	GND terminal



## ● IC301 (SC502167CPB): System Control / LCD Drive

Pin No.	Terminal Name	I/O	Function
1	BP0	O	LCD segment signal output terminal
2	RANDOM	I	RANDOM switch input terminal
3	RESUME	I	RESUME switch input terminal
4	PLAY	I	PLAY key input terminal
5	STOP	I	STOP key input terminal
6	SKP.F	I	SKIP.F key input terminal
7	SKP.R	I	SKIP.R key input terminal
8	REPEAT	I	REPEAT key input terminal
9	MEMORY	I	MEMORY key input terminal
10	PDOWN	O	Head amp OFF output terminal
11	MUTE	O	Hard muting output terminal
12	MLD	O	Serial command latch output terminal
13	VDD	I	Power supply terminal
14	OSC	-	Not used, open
15	OSC1	I	System clock input terminal
16	VSS	-	GND terminal
17	/RESET	O	Reset signal output terminal
18	MCLK	O	Serial command output terminal
19	SHOCK.P	I	SHOCK.P key input terminal
20	MDATA	I	Command data output terminal

Pin No.	Terminal Name	I/O	Function
21	BLKCK	I	Block clock input terminal
22	STAT	I	Status signal input terminal
23	HOLD	I	HOLD switch input terminal
24	REST	I	REST (innermost position) detection input terminal
25	OPEN	I	CD cover open detection terminal
26	BUZ	O	Beep control output terminal
27	XBS	I	XBS switch input terminal
28	TRAIN	-	Not used, open
29	LIGHT	-	Not used, open
30	STROBE1	O	Remote control data signal output terminal
31	STROBE2		
32	WRDRCN	-	Not used, connected to GND
33	WLSRCN	-	Not used, open
34	FP16	-	Not used, open
35 } 49	FP15 } FP1	O	LCD segment signal output terminal
50	BP3/FP0		
51	BP2	O	LCD segment signal output terminal
52	BP1		

## ● IC401 (BH6508FSE2): Motor Drive

Pin No.	Terminal Name	I/O	Function
1	MUTE4	I	CH4 muting terminal
2	CT	O	Triangular wave output terminal (Connected to capacitor)
3	IN1	I	CH1 input terminal
4	C1	O	CH1 filter terminal (Connected to capacitor)
5	PGND	-	GND terminal
6	1F	O	Focus coil driver output terminal
7	PVCC1	I	Power supply terminal
8	1R	O	Focus coil driver output terminal
9	PGND	-	GND terminal
10	2R	O	Tracking coil driver output terminal
11	PVCC2	I	Power supply terminal
12	2F	O	Tracking coil driver output terminal
13	PGND	-	GND terminal
14	C2	O	CH2 filter terminal (Connected to capacitor)
15	IN2	I	CH2 input terminal
16	VREF	I	Reference voltage output terminal

Pin No.	Terminal Name	I/O	Function
17	VCC	I	Power supply terminal
18	VG	I	Power supply terminal
19	IN3	I	CH3 input terminal
20	C3	O	CH3 filter terminal (Connected to capacitor)
21	PGND	-	GND terminal
22	3F	O	Traverse motor drive output terminal
23	PVCC3	I	Power supply terminal
24	3R	O	Traverse motor drive output terminal
25	PGND	-	GND terminal
26	4R	O	Spindle motor drive output terminal
27	PVCC4	I	Power supply terminal
28	4F	O	Spindle motor drive output terminal
29	C4	O	CH4 filter terminal (Connected to capacitor)
30	IN4	I	CH4 input terminal
31	GND	-	GND terminal
32	CLK	I	Clock input terminal

## ● IC501 (MN662780RPS2): Servo Processor / Digital Signal Processor / Digital Filter / D/A Converter

Pin No.	Terminal Name	I/O	Function
1	DVDD	I	Power supply terminal
2	D0	I/O	Data 0 input/output terminal
3	D1	I/O	Data 1 input/output terminal
4	NWE	O	Write enable output terminal
5	NRAS	O	RAS control signal output terminal
6	D2	I/O	Data 2 input/output terminal
7	D3	I/O	Data 3 input/output terminal
8	NCAS0	O	CAS control 0 signal output terminal
9	NCAS1	O	Address/0 signal output terminal
10 }	A8 }	O	Address 8~4 output terminal
14	A4		

Pin No.	Terminal Name	I/O	Function
15	A9	O	Address 9 output terminal
16 }	A0 }	O	Address 0~3 output terminal
19	A3		
20	VSS2	-	GND terminal
21	DVDD2	I	Power supply terminal
22	CK176	O	Clock output terminal (88.2kHz/44.1kHz)
23	TRVSTP	O	Traverse motor stop control terminal ("H" : Stop mode) (Not used, open)
24	TVD	O	Traverse drive signal output terminal
25	PC	O	Spindle motor drive signal output terminal ("L" : ON)
26	ECS	O	Spindle motor drive signal output terminal
27	TRD	O	Tracking drive kick pulse output terminal

Pin No.	Terminal Name	I/O	Function
28	FOD	O	Focus drive output terminal
29	FBAL	O	Focus balance adj. output terminal
30	TBAL	O	Tracking balance adj. output terminal
31	VREF	I	Reference voltage input terminal
32	FE	I	Focus error signal input terminal
33	TE	I	Tracking error signal input terminal
34	RFENV	I	RF envelope signal input terminal
35	OFT	I	OFF track signal input terminal ("H" : off track)
36	NRFDET	I	RF detect signal input terminal ("L" : detect)
37	BD0	I	Drop out signal input terminal ("H" : drop out)
38	LDON	O	Laser on signal output terminal ("H" : ON)
39	ARF	I	RF signal input terminal
40	IREF	I	Reference current input terminal
41	DRF	I	DSL bias terminal (Not used, open)
42	DSLFL	O	DSL loop filter output terminal
43	DSLFL2	O	DSL anbalance current correction output terminal
44	PLLFL	O	PLL loop filter output terminal
45	VCOFL	O	Loop filter output terminal
46	AVDD2	I	Power supply terminal
47	AVSS2	-	GND terminal
48	OUTL	O	Audio Lch output terminal
49	AVSS1	-	GND terminal
50	OUTR	O	Audio Rch output terminal
51	AVDD1	I	Power supply terminal
52	FSEL	-	Noise filter select terminal ("H" : ON, "L" : OFF)
53	TMOD1	-	Terminal mode select 1 terminal ("L" : normal)
54	TMOD2	-	Terminal mode select 2 terminal ("L" : normal)

Pin No.	Terminal Name	I/O	Function
55	FLAG	-	Flag signal output terminal (Not used, open)
56	PCLK	-	Crystal frame clock signal output terminal (Not used, open)
57	EXT0	O	Expansion port 0 output terminal
58	EXT1	-	Expansion port 1 output terminal (Not used, open)
59	EXT2	-	Expansion port 2 output terminal (Not used, open)
60	TX	O	Digital audio interface signal output terminal (Not used, open)
61	MCLK	I	Micon command clock signal input terminal
62	MDATA	I	Micon command data input terminal
63	MLD	I	Micon command load signal input terminal ("L" : load)
64	BLKCK	O	Sub code block clock signal output terminal (fBLKCK=75kHz)
65	SQCK	I	Sub code Q resistor clock input terminal
66	SUBQ	-	Sub code Q data output terminal (Not used, open)
67	DMUTE	-	Muting input terminal ("H" : mute) (Not used, connected to GND)
68	STAT	O	Status signal output terminal (RESY,CLVS,NTTSTOP,SQCK,FLAG6, SENSE,NTLOCK,BSSEL,SUBQ DATA, CD TEXT DATA,ANTISHOCK LOAD DATA)
69	NRST	I	Reset input terminal ("L" : reset)
70	ARST	-	Test terminal ("L" : normal)
71	PMCK	O	Clock signal output terminal (88.2kHz)
72	SMCK	O	Clock signal output terminal (4.2336MHz)
73	SUBC	O	Sub code output terminal (Not used, open)
74	SBCK	I	Sub code output clock input terminal
75	NCLDCK	O	Sub code frame clock output terminal (fCLOCK=7.35kHz) (Not used, open)
76	NTEST	I	Test terminal ("H" : normal)
77	X1	I	Crystal oscillator input terminal (f=16.9344MHz)
78	X2	O	Crystal oscillator output terminal (f=16.9344MHz)
79	DVDD1	I	Power supply terminal
80	DVSS1	-	GND terminal

# Printed Circuit Board and Wiring Connection Diagram

• This circuit board diagram may be modified at any time with the development of new technology.

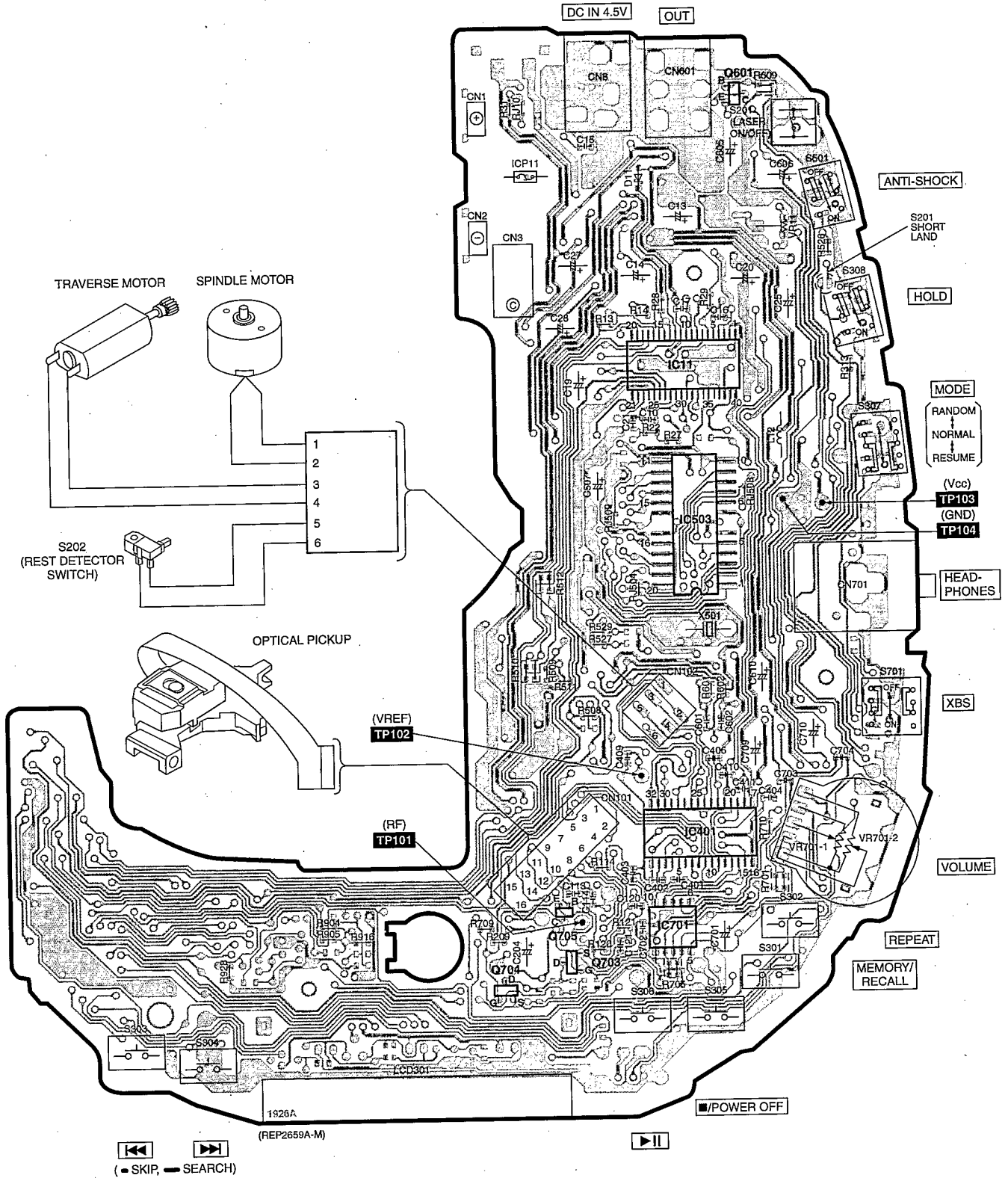

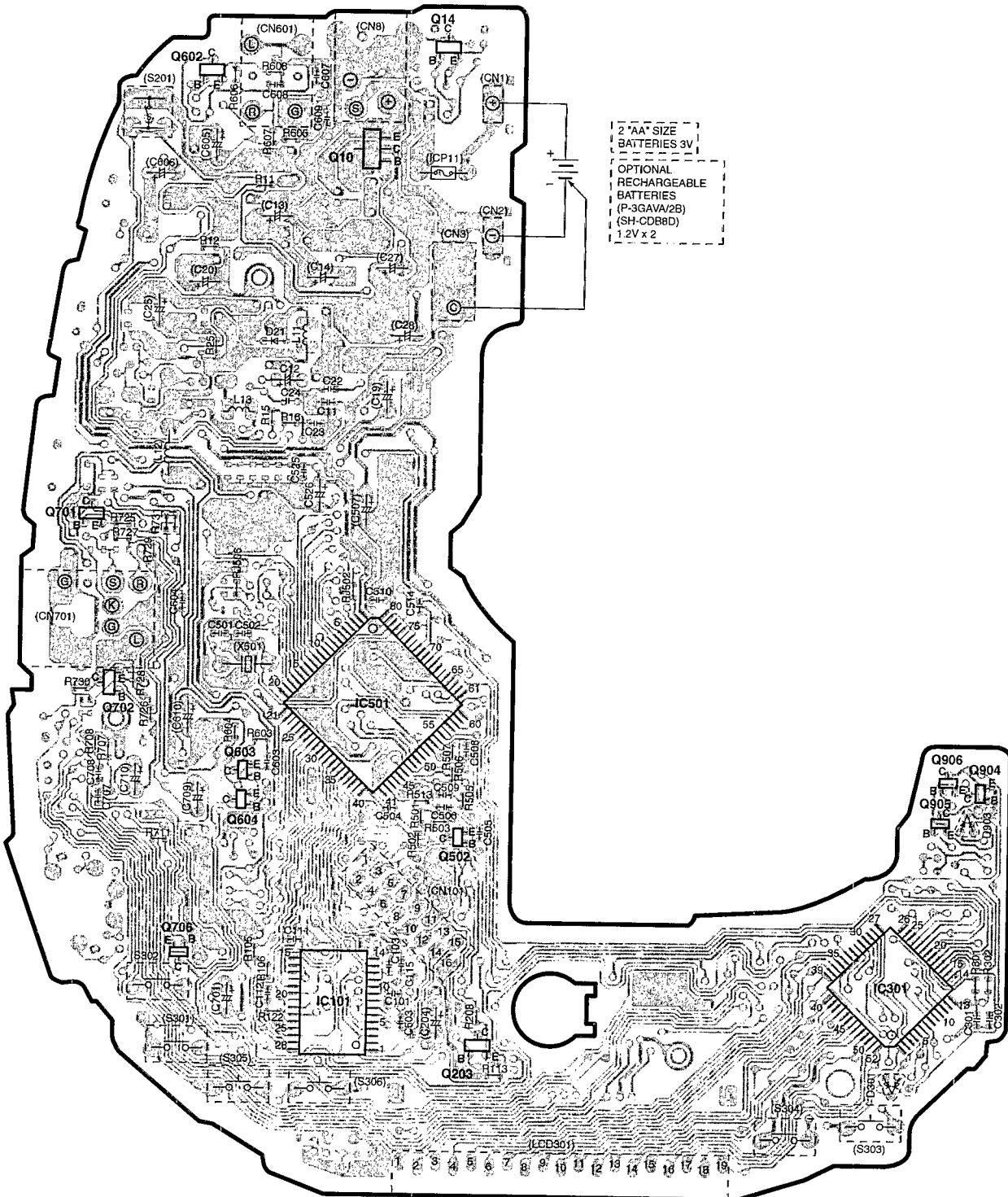

2 AA SIZE  
BATTERIES 3V  
OPTIONAL  
RECHARGEABLE  
BATTERIES  
(P-3GAVA/2B)  
(SH-CDB8D)  
1.2V x 2

# Block Diagram

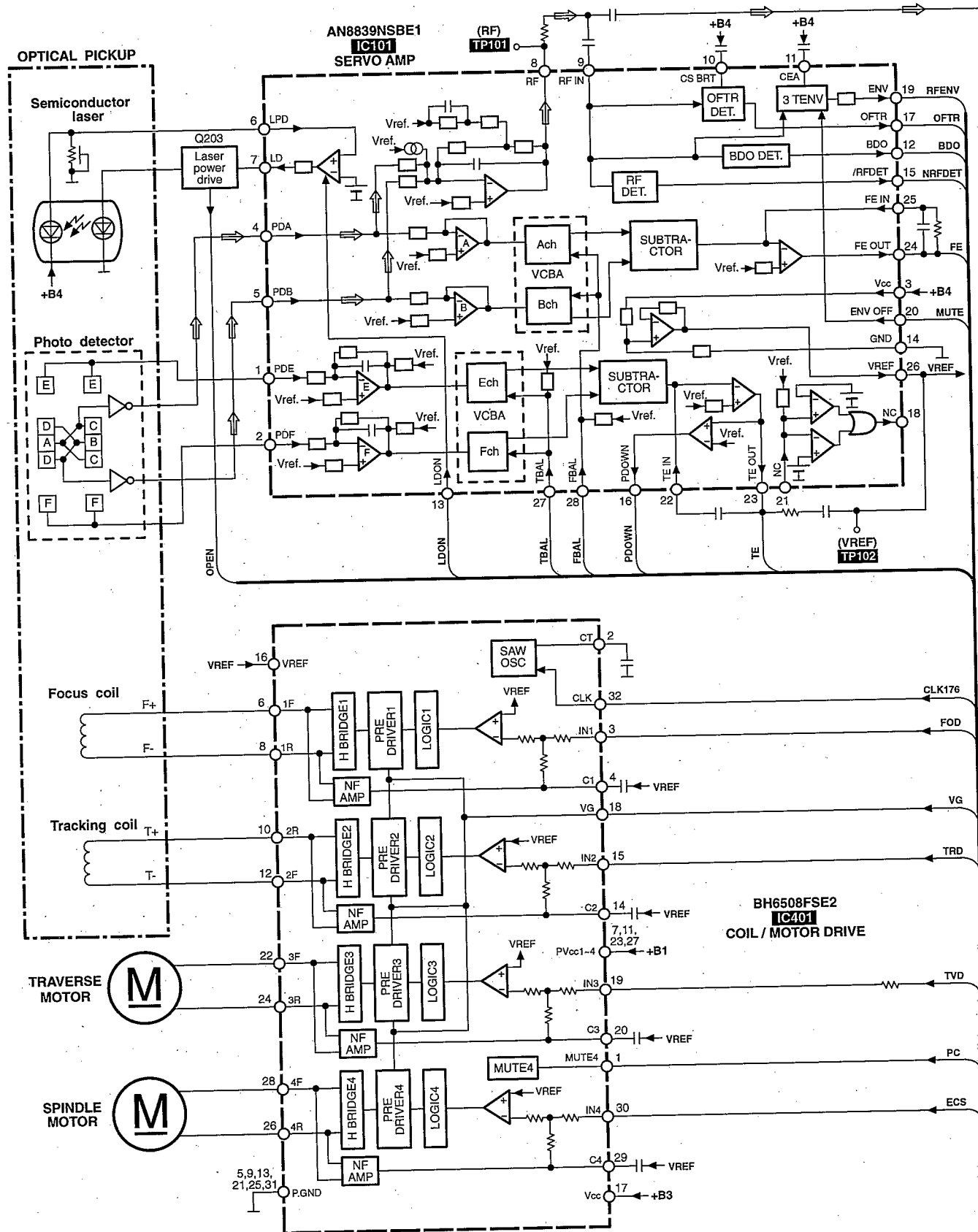

MN662780RPS2  
**IC501**  
 SERVO PROCESSOR / DIGITAL SIGNAL PROCESSOR  
 DIGITAL FILTER & D/A CONVERTER

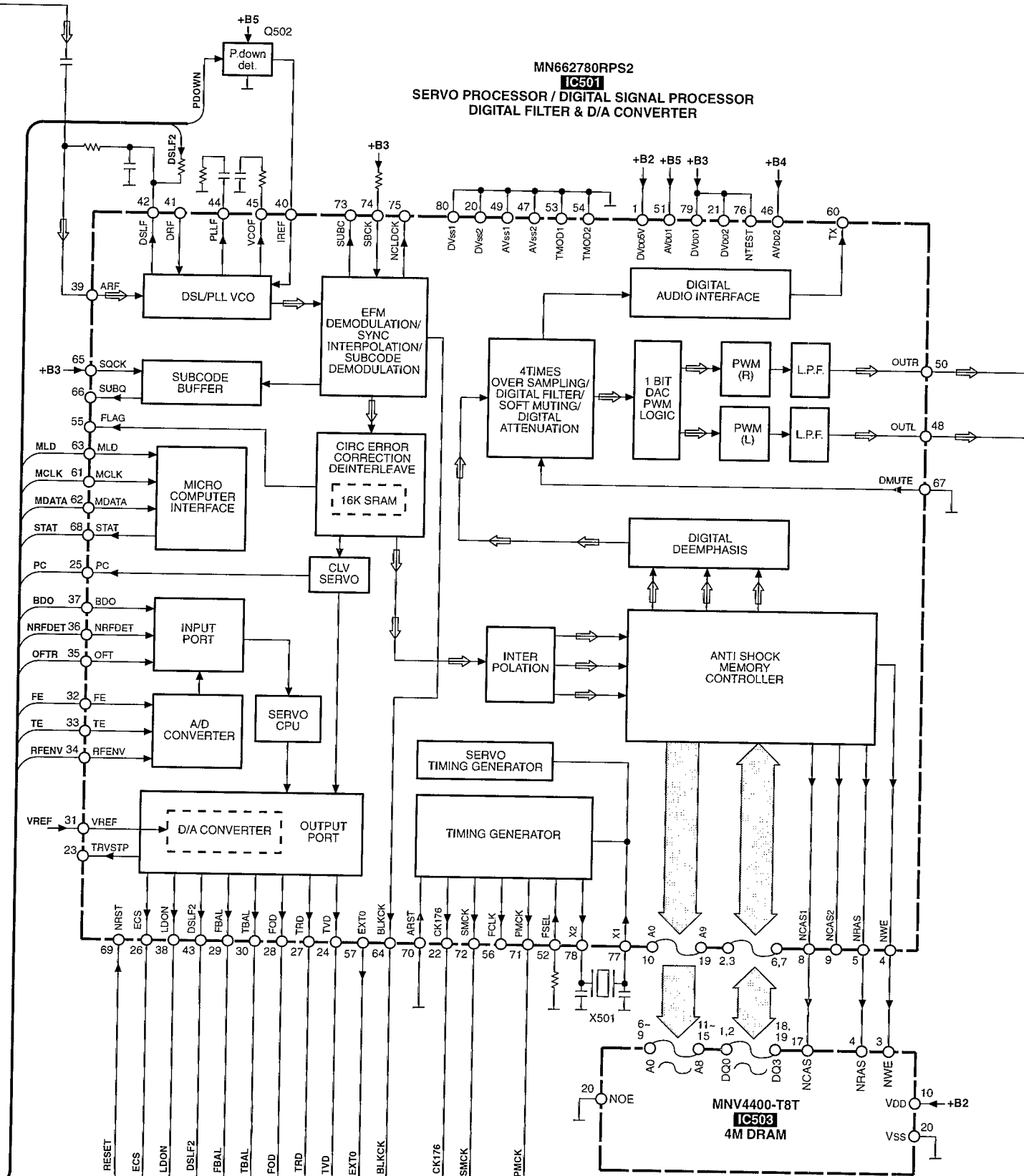

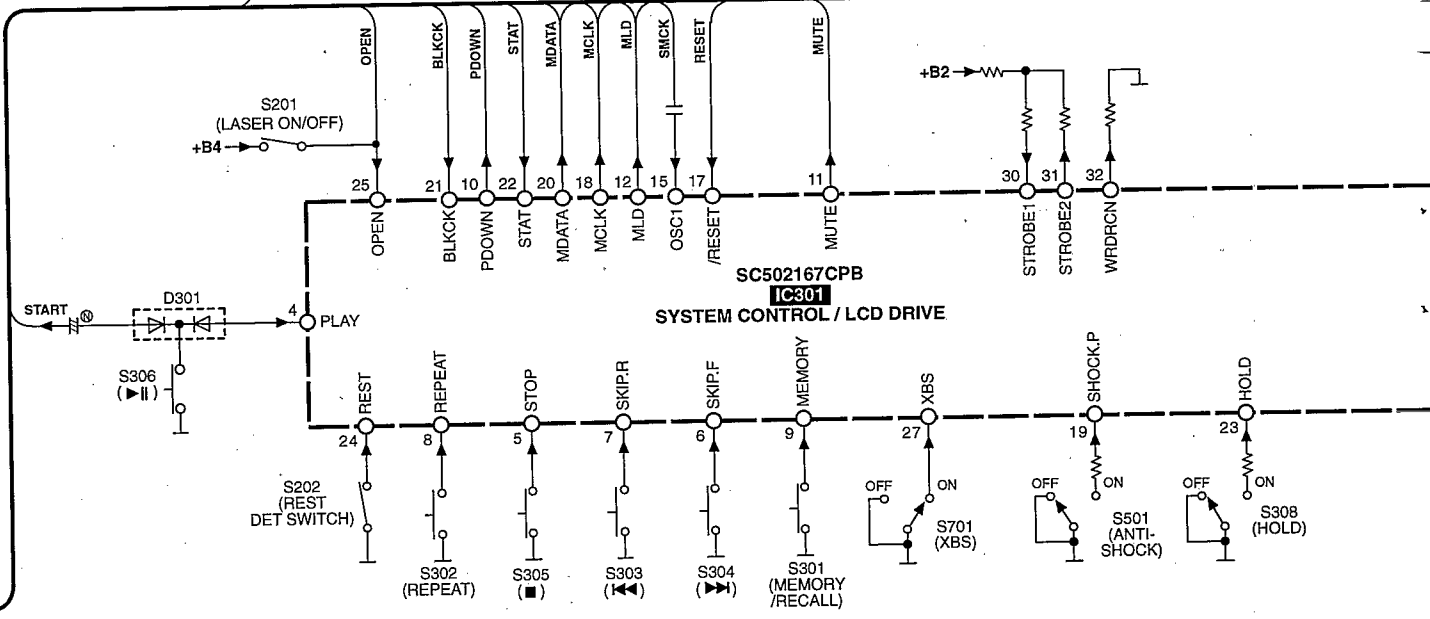
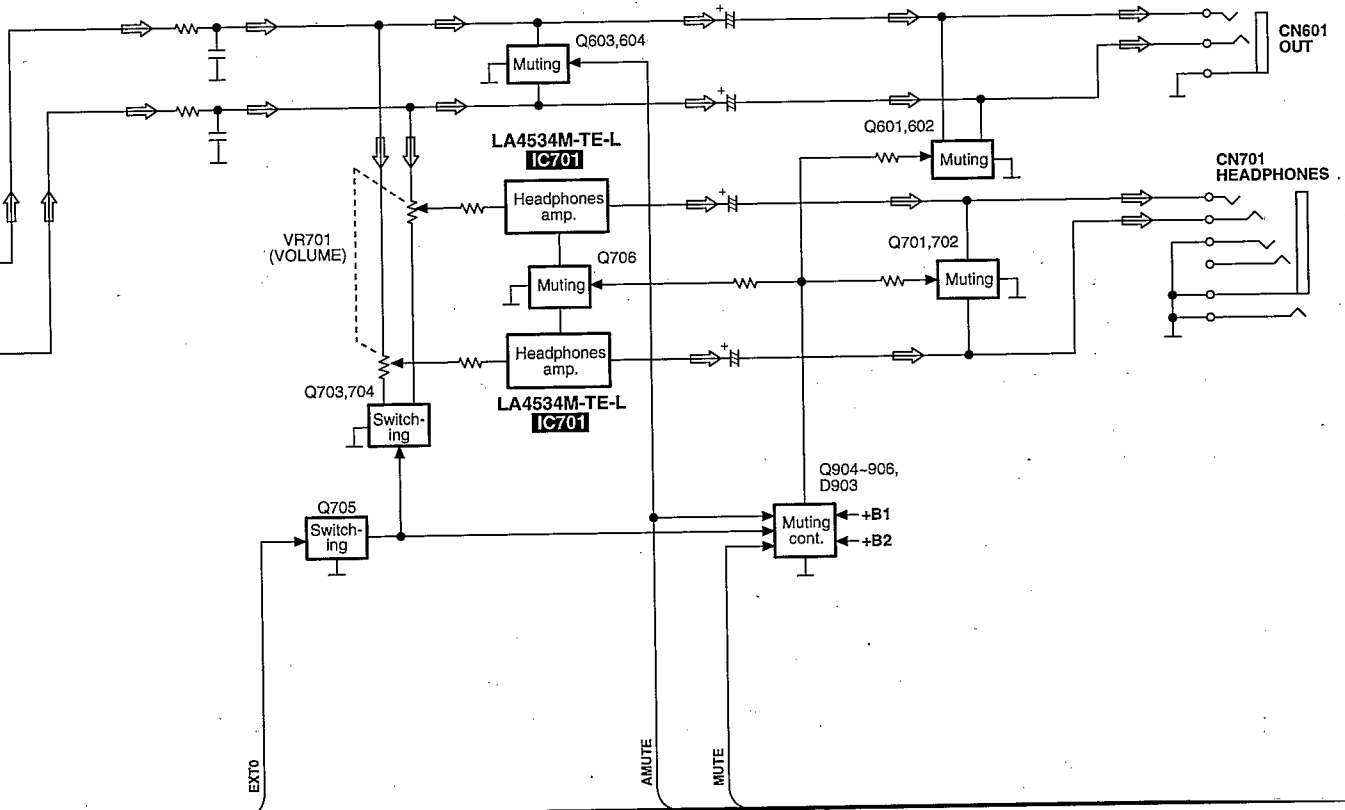



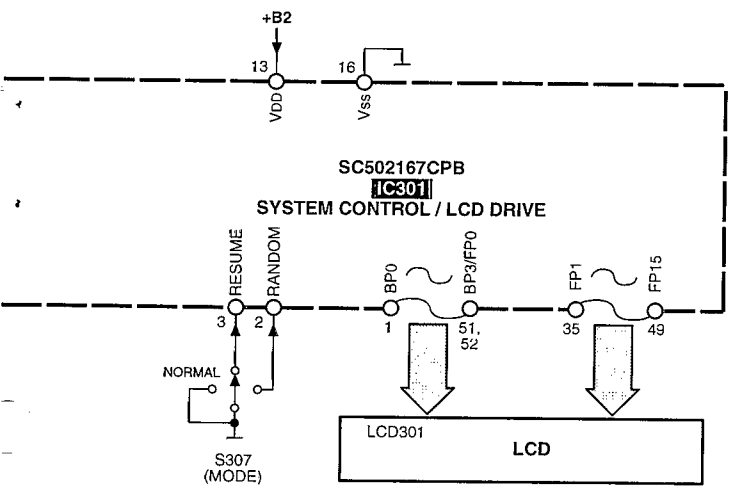
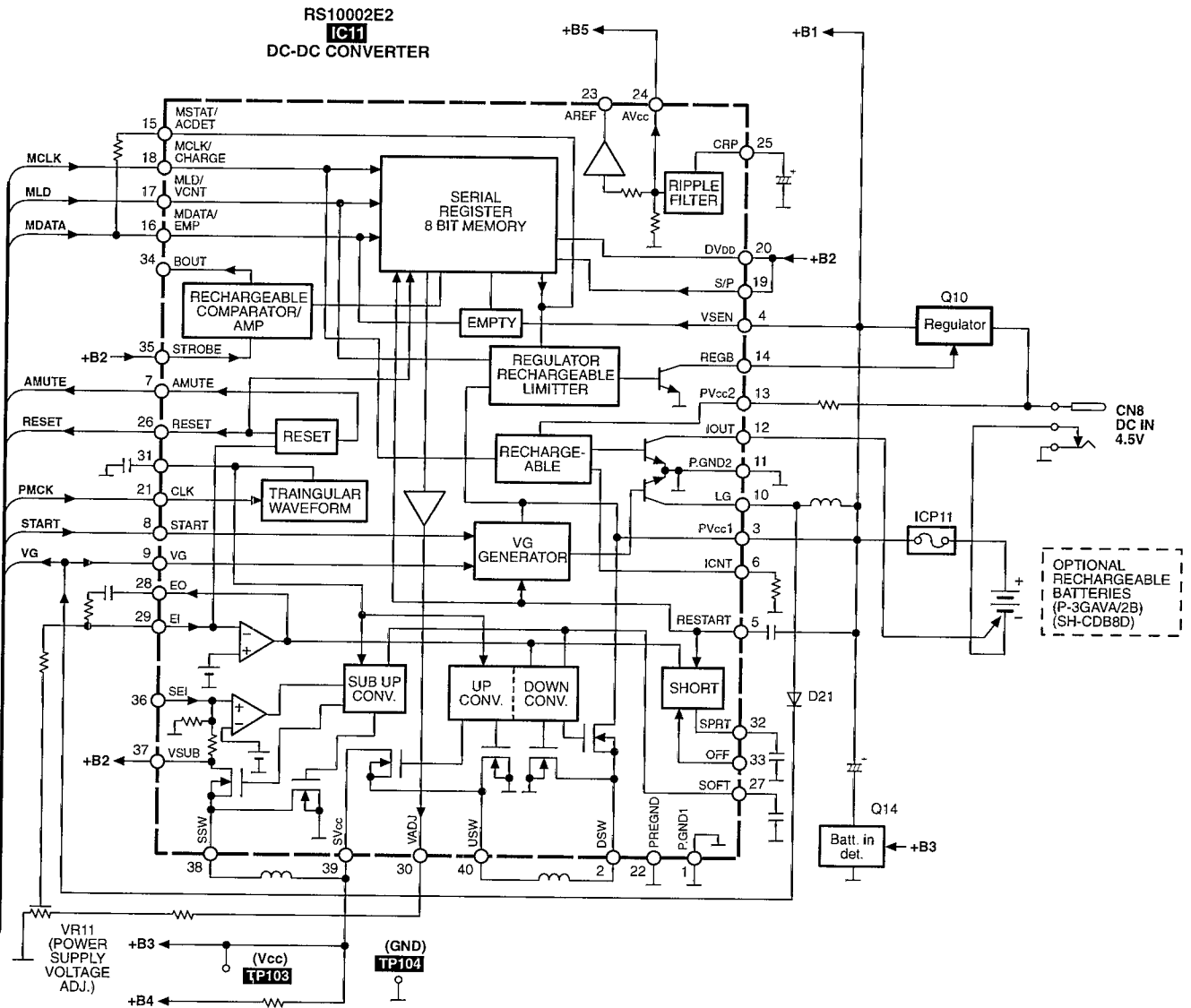

Note → : Audio signal

# Replacement Parts List

**Notes:**

- Important safety notice:

Components identified by  $\Delta$  mark have special characteristics important for safety.

Furthermore, special parts which have purposes of fire-retardant (resistors), high-quality sound (capacitors), low-noise (resistors), etc. are used.

When replacing any of components, be sure to use only manufacturer's specified parts shown in the parts list.

- The parenthesized indications in the Remarks columns specify the areas. (Refer to the cover page for area.)

- ALL parts are supplied by MESA.

- "<IA>," <IB>" marks in Remarks indicate language of instruction manual. [ $\Delta$ <IA>: English, <IB>: Canadian/French]

- \* This item is not attached to merchandise, but it is supplied as a replacement parts.

Ref.No.	Part No.	Part Name & Description	Pcs	Remarks
1	RFKJLS230P-S	BOTTOM CABINET ASS'Y	1	
1-1	RKAD063-K	FOOT	2	
2	RKK0102-K	BATTERY COVER	1	
3	RJF0030	LCD HOLDER	1	
4	RGV0200-K	SLIDE KNOB	3	
5	RJC93020	COMMON BATTERY TERMINAL	1	
6	RMA0677	REAR ORNAMENT PLATE	1	
7	RYF0460-S	CD COVER ASS'Y	1	
8	RYK0718A-H	INTERMEDIATE CABINET ASS'	1	
8-1	RGU1495-H	KNOB	1	
8-2	RGU1494-H	KNOB	1	
8-3	RME0241	SPRING	1	
8-4	RWL0472	STOPPER	1	
9	XTN17+6GFZ	SCREW	4	
$\Delta$ 10	RAE0145Z	TRAVERSE DECK	1	
10-1	RMG0449-H	FLOATING RUBBER	3	
11	RGV0200-H	SLIDE KNOB	1	
12	RJC93015-1	BATT. TERMINAL (+) (-)	2	
13	RJH5104	RECHARGE. BATT. TERMINAL	1	
$\Delta$ A1	RFEA415C-S	AC ADAPTOR	1 (P)	
A2	RFEV705P-KS	STEREO HEADPHONES	1 (P)	
A3	RQT4322-P	INSTRUCTION MANUAL	1 (P)<IA>	
$\Delta$ A10	RFEA415C-S	AC ADAPTOR	1 (PC)	
A11	RFEV317P-KS	STEREO HEADPHONES	1 (PC)	
A12	SQX9131	SERVICE CENTER LIST	1 (PC)	
A13	RQT4322-P	INSTRUCTION MANUAL	1 (PC)<IA>	
A14	RQT4323-C	INSTRUCTION MANUAL	1 (PC)<IB>	
A15*	RKB205ZA-0	EAR PADS	1 (PC)	
C10	ECUV1H121KCV	50V 120P	1	
C11	ECUVNA105ZV	10V 1U	1	
C12	RCST1AY475RE	10V 4.7U	1	
C13	RCE0JSC4701X	6.3V 47U	1	
C14	RCE0JKA2211G	6.3V 220U	1	
C15	ECUZNC104ZV	16V 0.1U	1	
C16, 17	ECUVNA105ZV	10V 1U	2	
C19	ECEA1AKA220I	16V 22U	1	
C20	ECEA1HKA010I	50V 1U	1	
C21	ECUV1E103KBV	25V 0.01U	1	
C22	ECUZNC104ZV	16V 0.1U	1	
C23	ECUVNA105ZV	10V 1U	1	
C24	ECUV1H561KBV	50V 560P	1	
C25	ECEA1HKA010I	50V 1U	1	
C27	RCE1AMT3311V	10V 330U	1	
C28	RCE0GMT5611V	4V 560U	1	
C101	ECUV1C104KBV	16V 0.1U	1	
C103	ECUV1E103KBV	25V 0.01U	1	

Ref.No.	Part No.	Part Name & Description	Pcs	Remarks
C111	ECUV1C223KBV	16V 0.022U	1	
C112	ECUV1H391KBV	50V 390P	1	
C113, 14	ECUZNC104ZV	16V 0.1U	2	
C115	ECUV1C223KBV	16V 0.022U	1	
C120	ECUV1H332KBV	50V 3300P	1	
C121	ECUV1H271KBV	50V 270P	1	
C204	RCE1AKA4701G	10V 47U	1	
C301, 02	ECUVNA105ZV	10V 1U	2	
C401	ECUV1H102KBV	50V 1000P	1	
C402-04	ECUV1E123KBV	25V 0.012U	3	
C406	ECUVNA105ZV	10V 1U	1	
C409	ECUV1E123KBV	25V 0.012U	1	
C410	ECUVNA105ZV	10V 1U	1	
C411	ECUZNC104ZV	16V 0.1U	1	
C501, 02	ECUV1H150KCV	50V 15P	2	
C503	ECUV1H561KBV	50V 560P	1	
C504	ECUZNC104ZV	16V 0.1U	1	
C505	ECUV1C223KBV	16V 0.022U	1	
C506	ECUVNA224KBV	10V 0.22U	1	
C507	RCE0JKA2211G	6.3V 220U	1	
C508	ECUV0J474KBV	6.3V 0.47U	1	
C509	ECUV1E103KBV	25V 0.01U	1	
C510	ECUZNC104ZV	16V 0.1U	1	
C514	ECUV1H102KBV	50V 1000P	1	
C525	ECUZNC104ZV	16V 0.1U	1	
C526	RCST1AY475RE	10V 4.7U	1	
C601, 02	ECUV1H102KBV	50V 1000P	2	
C603, 04	ECUV1H272KBV	50V 2700P	2	
C605, 06	ECEA1CKA100I	16V 10U	2	
C607, 08	ECUV1H681KBV	50V 680P	2	
C609	ECUZNC104ZV	16V 0.1U	1	
C610	RCE1AKA4701G	10V 47U	1	
C701	RCE1AKA4701G	10V 47U	1	
C702	ECUZNC104ZV	16V 0.1U	1	
C703, 04	ECUVNA105ZV	10V 1U	2	
C707, 08	ECUVNA154KBV	10V 0.15U	2	
C709, 10	ECA0JAK2211X	6.3V 220U	2	
CN8	RJJ43K09-C	JACK, DC 1N	1	
CN101	RJS2A4716M1	CONNECTOR (16P)	1	
CN102	RJS2A5106T1	CONNECTOR (6P)	1	
CN601	RJD3S5ZA-C	JACK, OUT	1	
CN701	RJJ33TK07-C	JACK, HEADPHONES	1	
D11	MA2ZD0200L	DIODE	1	
D21	MA110TX	DIODE	1	
D301	M1MA141WKT1	DIODE	1	
D903	M1MA141WKT1	DIODE	1	
IC11	RST0002E2	IC	1	
IC101	AN8839NSBEI	IC	1	
IC301	SC502167CPB	IC	1	
IC401	BH6508FSE2	IC	1	
IC501	MN662780RPS2	IC	1	
IC503	MNV4400-T8T	IC	1	
IC701	LA4534M-TE-L	IC	1	
$\Delta$ ICP11	UNH000700A	IC PROTECTOR	1	
L11	RLQU331KT-W	COIL	1	
L12	RLQB101KT-D	COIL	1	
L13	RLQU331KT-W	COIL	1	
L601, 02	ERJ3GEY0R00V	CHIP JUMPER	2	
LCD301	RSL5203-C	LCD	1	
P1	RPN1044	COVER	1 (P)	
P2	RPN1124	TRAY	1 (P)	
P3	RPQ0850	GROUND PAPER	1 (P)	
P10	RPQ0999	PACKING CASE	1 (PC)	
P11	RPQ0752	SPACER	1 (PC)	
P12	RPQ0836	PAD	1 (PC)	
P13	RPQ0046	PROTECTION BAG (F.B.)	1 (PC)	
P14	RPQ0111	PROTECTION BAG (UNIT)	1 (PC)	

Ref. No.	Part No.	Part Name & Description	Pcs	Remarks	Ref. No.	Part No.	Part Name & Description	Pcs	Remarks
Q10	2SB766ATX	TRANSISTOR	1		S301-06	EVQ11G05R	SW	6	
Q14	2SD1328TX	TRANSISTOR	1		S307	RSS3A007-1A	SW	1	
Q203	MSB709RST1	TRANSISTOR	1		S308	RSS2A010-1A	SW	1	
Q502	UN5115TX	TRANSISTOR	1		S501	RSS2A010-1A	SW	1	
Q601, 02	2SD1328TX	TRANSISTOR	2		S701	RSS2A010-1A	SW	1	
Q603, 04	DTC114TUA106	TRANSISTOR	2		VR11	RRN3A05B33WL	V. R.	1	
Q701, 02	2SD1328TX	TRANSISTOR	2		VR701	EVUTUF811C54	V. R.	1	
Q703, 04	2SK2158T1	TRANSISTOR	2		X501	RSXZ16M9M01T	OSCILLATOR	1	
Q705	DTC144TUA106	TRANSISTOR	1						
Q706	2SD1819ATX	TRANSISTOR	1						
Q904	DTA114YUA106	TRANSISTOR	1						
Q905, 06	DTC144TUA106	TRANSISTOR	2						
R11	ERJ3GEYJ822V	1/16W 8.2K	1						
R12	ERJ3GEYJ332V	1/16W 3.3K	1						
R13	ERJ3GEYJ102Z	1/16W 1K	1						
R14	ERJ3GEYJ222V	1/16W 1	1						
R15, 16	ERJ3GEYJ393V	1/16W 39K	2						
R22	ERJ3GEYJ223V	1/16W 22K	1						
R25	ERJ3GEYJ104Z	1/16W 100K	1						
R27	ERJ3GEYJ392V	1/16W 3.9K	1						
R28	ERJ3GEYJ100V	1/16W 10	1						
R29	ERJ3GEYJ682V	1/16W 6.8K	1						
R31	ERJ3GEYJ152V	1/16W 1.5	1						
R105, 06	ERJ3GEYR00V	CHIP JUMPER	2						
R113, 14	ERJ3GEYJ330V	1/16W 33	2						
R120	ERJ3GEYJ472V	1/16W 4.7K	1						
R121	ERJ3GEYJ563V	1/16W 56K	1						
R122	ERJ3GEYJ683V	1/16W 68K	1						
R208	ERJ3GEYJ2R2V	1/16W 2.2	1						
R209	ERJ3GEYJ223V	1/16W 22K	1						
R301	ERJ3GEYJ392V	1/16W 3.9K	1						
R302	ERJ3GEYJ104Z	1/16W 100K	1						
R313	ERJ3GEYJ102Z	1/16W 1K	1						
R501	ERJ3GEYJ683V	1/16W 68K	1						
R502	ERJ3GEYJ563V	1/16W 56K	1						
R503	ERJ3GEYJ224V	1/16W 220K	1						
R505	ERJ3GEYJ391V	1/16W 390	1						
R506	ERJ3GEYJ222V	1/16W 2.2K	1						
R507	ERJ3GEYJ103Z	1/16W 10K	1						
R508	ERJ3GEYJ1R0V	1/16W 1	1						
R509	ERJ3GEYJ223V	1/16W 22K	1						
R510	EXBV4V103JV	1/32W 10K	1						
R511	ERJ3GEYJ472V	1/16W 4.7K	1						
R512	EXBV4V222JV	1/32W 2.2K	1						
R513	ERJ3GEYJ104Z	1/16W 100K	1						
R526	ERJ3GEYJ102Z	1/16W 1K	1						
R527	ERJ3GEYJ104Z	1/16W 100K	1						
R529	ERJ3GEYJ104Z	1/16W 100K	1						
R601, 02	ERJ3GEYJ681V	1/16W 680	2						
R603, 04	ERJ3GEYJ561V	1/16W 560	2						
R605, 06	ERJ3GEYJ473V	1/16W 47K	2						
R607, 08	ERJ3GEYJ102Z	1/16W 1K	2						
R609	EXBV4V332JV	1/32W 3.3K	1						
R701	EXBV4V472JV	1/32W 4.7K	1						
R705	EXBV4V472JV	1/32W 4.7K	1						
R707, 08	ERJ3GEYJ4R7V	1/16W 4.7	2						
R709, 10	ERJ3GEYJ104Z	1/16W 100K	2						
R711	ERJ3GEYJ331V	1/16W 330	1						
R725, 26	ERJ3GEYJ150V	1/16W 15	2						
R727, 28	ERJ3GEYJ1R5V	1/16W 1.5	2						
R729, 30	ERJ3GEYJ472V	1/16W 4.7K	2						
R731	EXBV4V331JV	1/32W 330	1						
R904	ERJ3GEYJ123V	1/16W 12K	1						
R905	ERJ3GEYJ393V	1/16W 39K	1						
R916	ERJ3GEYJ823V	1/16W 82K	1						
R928	ERJ3GEYJ473V	1/16W 47K	1						
RJ10	ERJ3GEYR00V	CHIP JUMPER	1						
RJ502	ERJ3GEYR00V	CHIP JUMPER	1						
RJ504	ERJ3GEYR00V	CHIP JUMPER	1						
RJ508	ERJ3GEYR00V	CHIP JUMPER	1						
RJ508, 09	ERJ3GEYR00V	CHIP JUMPER	2						
S201	ESE11SV6	SW	1						

# ■ Cabinet Parts Location

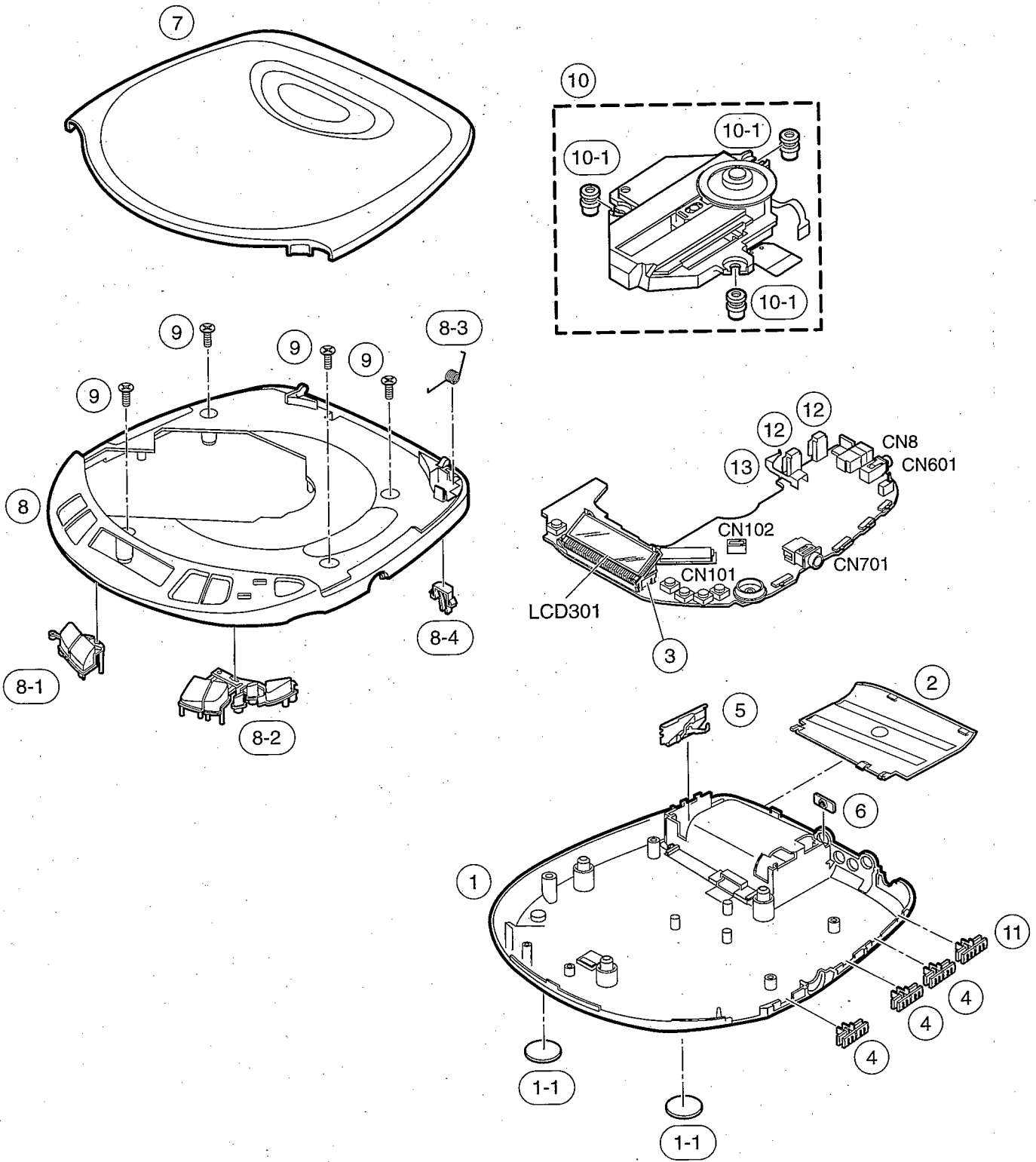

# ■ Packaging

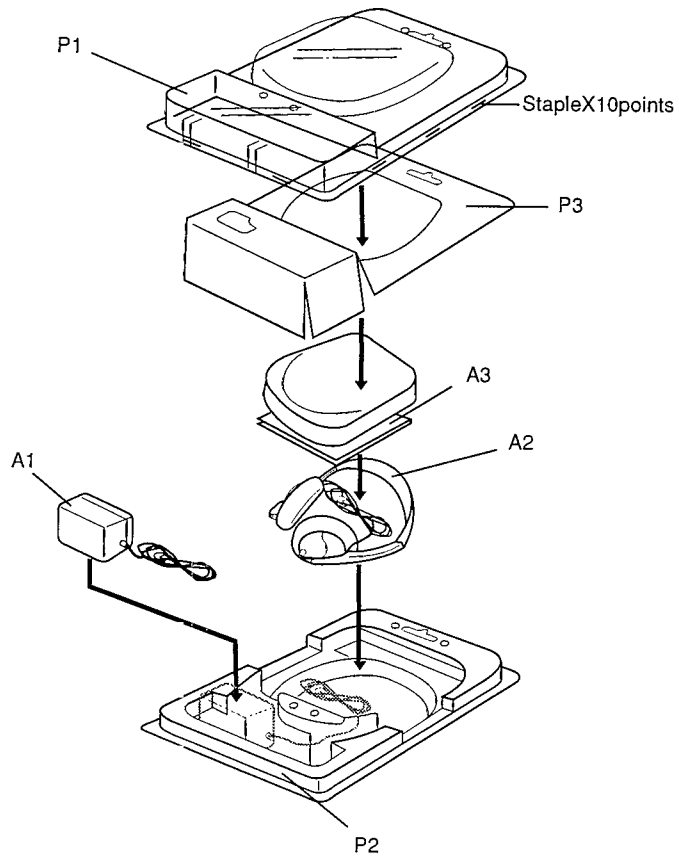

SL-S230(P)

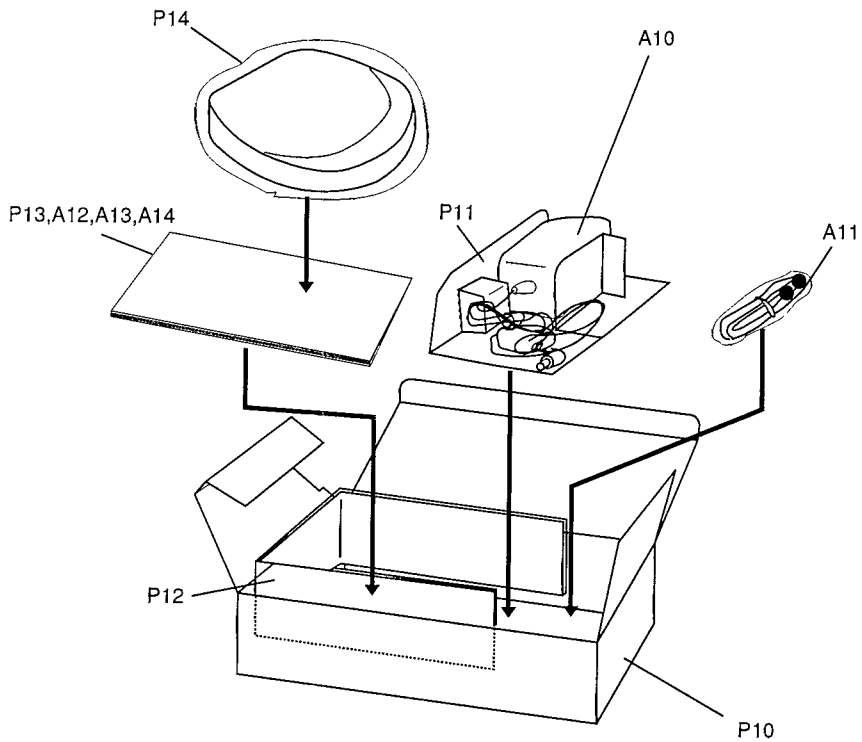

SL-S230(PC)

599