

Service Manual

COMPACT
disc
DIGITAL AUDIO

MASH[®]
multi-stage noise shaping

Portable CD Player
SL-S270

Colour

(K) Black Type

※ MASH is a trademark of NTT.

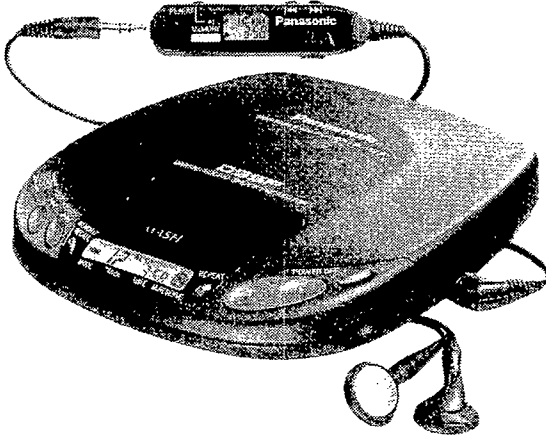

Areas

Suffix for Model No.	Areas	Colour
[GK]	China	(K)
[GH]	Hong Kong	

TRAVERSE DECK: RAE0141Z MECHANISM SERIES

■ SPECIFICATIONS

■ Audio

No. of channels: 2 channels (left and right, stereo)
Output voltage: 0.6 V (50 kΩ) ϕ 3.5 stereo mini jack
Frequency response: 20~20,000 Hz (+0.5 dB, -1.5 dB)
S/N: more than 94 dB*
Wow and flutter: Below measurable limit
DA converter: 1 bit, MASH*
Headphone output level: max. 9 mW+9 mW/16Ω (variable)
 stereo mini jack ϕ 3.5
Digital filter: 8 times over sampling

■ Signal Format

Correction system: Technics New
Super Decoding Algorithm

■ Pickup

Type: One beam
Light source: Semiconductor laser
Wavelength: 780 nm
Lens: Glass pressed lens

■ Playing time;

[When used in hold mode, at 25°C (77°F) temperature and on flat and stable surface.]

Batteries used	DSSP OFF/ON
Rechargeable batteries	About 3 hours/ About 2 hours 30 minutes
Panasonic alkaline dry cell batteries	About 10 hours/ About 7 hours 30 minutes

The play time may be less depending on the operating conditions.

Recharging time;

About 3 hours

■ General

Power requirement:

AC; with an included Panasonic AC adaptor
 RFEA401E-3S (GK)
 RFEA401E-2S (GH)
 Batteries; DC 3 V (two "AA" size batteries, not included)
 (Panasonic R6P/LR6 or equivalent, not included)
 Rechargeable Batteries; DC 2.4 V with an optional Panasonic Rechargeable Batteries (SH-CDB8D set of 2)
 Car Battery; with an optional Panasonic car adaptor (SH-CDC9)
 DC 4.5 V \diamond \ominus \diamond

DC IN:

Operation temperature range:

0°C-40°C (32°F-104°F)

Rechargeable

temperature range:

5°C-40°C (41°F-104°F)

Power supply:

DC 4.5 V

Power consumption:

Power source	DSSP OFF/ON
Using AC adaptor	5.5W/5.7W

Dimensions (W×H×D):

128×29×140 mm

Weight:

225 g without batteries
 270 g with batteries

*These specifications were measured in the DSSP OFF mode.

Note: Design and specifications are subject to change without notice. Weight and dimensions are approximate.

Panasonic[®]



Panasonic/Technics

© 1997 Matsushita Electric Industrial Co., Ltd.
 All rights reserved. Unauthorized copying and distribution is a violation of law.

⚠ WARNING

This service information is designed for experienced repair technicians only and is not designed for use by the general public. It does not contain warnings or cautions to advise non-technical individuals of potential dangers in attempting to service a product. Products powered by electricity should be serviced or repaired only by experienced professional technicians. Any attempt to service or repair the product or products dealt with in this service information by anyone else could result in serious injury or death.

■ CONTENTS

	Page		Page
PRECAUTION OF LASER DIODE	2	AUTOMATIC ADJUSTMENT RESULTS	
ACCESSORIES	3	DISPLAY FUNCTION (SELF-CHECK FUNCTION)	12, 13
LOCATION OF CONTROLS	3	MEASUREMENTS AND ADJUSTMENTS	13, 14
POWER SUPPLY PREPARATIONS	3, 4	BLOCK DIAGRAM.....	15~18
ACCIDENTAL OPERATION PREVENTION FUNCTION	4	SCHEMATIC DIAGRAM.....	19~23
SEQUENTIAL PLAY	5	PRINTED CIRCUIT BOARD AND	
USING THE WIRED REMOTE CONTROLLER	6	WIRING CONNECTION DIAGRAM.....	24
USING THE UNIT WITH OPTIONAL ACCESSORIES	6	REPAIRING THE PRINTED RESISTOR.....	25
HANDLING PRECAUTIONS FOR TRAVERSE DECK	7	TERMINAL GUIDE.....	26~31
OPERATION CHECKS AND MAIN		CABINET PARTS LOCATION	32
COMPONENT REPLACEMENT PROCEDURES	8~10	REPLACEMENT PARTS LIST	33, 34
CHECKING THE OPERATION PROBLEMS ON		PACKAGING	34
THE TRAVERSE DECK (OPTICAL PICKUP)	11	RESISTORS AND CAPACITORS	35

■ PRECAUTION OF LASER DIODE

CAUTION: This unit utilizes a class 1 laser. Invisible laser radiation is emitted from the optical pickup lens when the unit is turned on :

1. Do not look directly into the pickup lens.
2. Do not use optical instruments to look at the pickup lens.
3. Do not adjust the preset variable resistor on the optical pickup.
4. Do not disassemble the optical pickup unit.
5. If the optical pickup is replaced, use the manufactures specified replacement pickup only.
6. Use of control or adjustments or performance of procedures other than those specified herin may result in hazardous radiation exposure.

Caution:

This is a laser product.

Improper process of control, adjustment and operation not written in this hand book may cause serious radiation leakage.

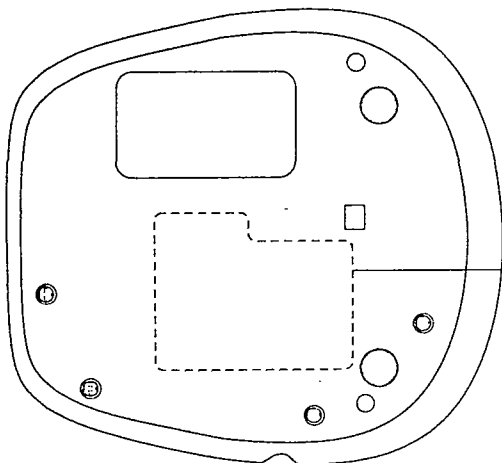

(Bottom Side)

RQLS0077-2

CLASS 1 LASER PRODUCT		<p>VARO! Avattaessa ja suojalukitus ohitettaessa olet alttiina näkymätön lasersäteilylle. Älä katso säteeseen.</p> <p>VARNING! Osynlig laserstrålning när denna del är öppnad och spårren är urkopplad. Beträkta ej strålen.</p>
<p>ADVARSEL USYMLIG LASERSTRÅLING VED ÅBNING, NÅR SIKKERHEDSÅF-BRYDERE ER UDE AF FUNKTION. UNDGÅ UDSÆTTELSE FOR STRÅLING</p>		
<p>VORSICHT Unsichtbare Laserstrahlung wenn Abdeckung geöffnet und Sicherheitsverriegelung überdruckt. Nicht dem Strahl aussetzen</p>	<p>DANGER Invisible Laser radiation when open and interlock defeated. AVOID DIRECT EXPOSURE TO BEAM</p>	<p>ADVERSEL! Usynlig laserstrålning när deksel åpnes og sikkerhedsås brytes. Unngå eksponering for strålen. RQLS0077-2</p>

ACCESSORIES

AC adaptor..... 1
(RFEA401E-3S) (GK)
(RFEA401E-2S) (GH)

Remote control..... 1
(RFEV002PCK1S)

Stereo earphones..... 1
(RFEV315P-KS)

Battery case..... 1
(RFA0708-K)

LOCATION OF CONTROLS

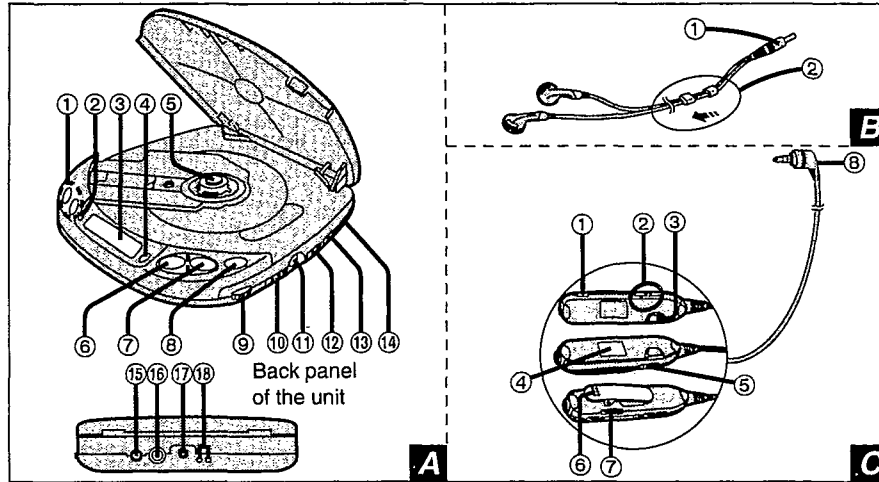

Main unit **A**

- ① Skip/search buttons (◀, ▶) •SKIP/SEARCH
- ② Memory/recall button (MEMORY/RECALL)
- ③ Display
- ④ Repeat button (REPEAT)
- ⑤ Push button (PUSH)
- ⑥ Play/pause button (▶ II)
- ⑦ Stop/power off button (■/POWER OFF)
- ⑧ Open button (OPEN)
- ⑨ Headphones volume control (VOLUME)
- ⑩ Train, S-XBS selector (TRAIN, S-XBS, OFF)
- ⑪ Headphones jack (Ⓜ) 16 Ω φ 3.5

- ⑫ Play mode selector (MODE)
- ⑬ Hold switch (HOLD)
- ⑭ Digital sound shock protector switch (DSSP)
- ⑮ Out jack (OUT)
- ⑯ DC in jack (DC IN 4.5 V ⚡)
- ⑰ Hole for car mounting base/battery case
- ⑱ Connection terminal for battery case

Stereo earphones **B**

- ① Plug
- ② Slider
Slide up to prevent entangling of the cord when the stereo earphones are not in use.

Wired remote controller **C**

- ① Repeat button (REPEAT)
- ② Skip/search buttons (◀, ▶)
- ③ Play/stop/off button
- ④ Display
- ⑤ Hold switch (HOLD)
- ⑥ Clip
- ⑦ Volume control (VOL)
- ⑧ Plug

POWER SUPPLY PREPARATIONS

Refer to the specifications (page 12) for the duration of the play time provided when rechargeable or dry cell batteries are used.

Using the rechargeable batteries (not included)

Obtain the optional rechargeable batteries (SH-CDB8D).

Make sure that the rechargeable batteries have been recharged before use.

Recharging procedure

- 1** Place the rechargeable batteries inside the unit.

(No batteries other than SH-CDB8D can be recharged.)

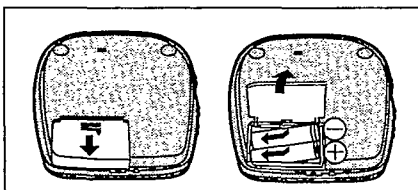

- 2** Connect the AC adaptor.

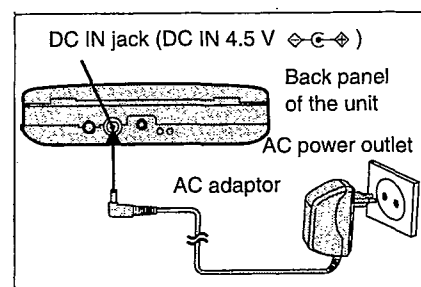

It takes about 3 hours to recharge the batteries fully.

- 3** Upon completion of the recharging, disconnect the AC adaptor from the DC IN jack and power outlet.

- The batteries can be used for about 10 months (300 times) if they are used every day. They will need to be replaced if the duration of their operation drops drastically.
- You can operate the unit with the AC adaptor while recharging the batteries, but it will lengthen the recharging time.
- Recharging should be performed at 5°C–40°C.
- While recharging, the AC adaptor and rechargeable batteries may get warm. This is normal.

Removing the batteries

Push the batteries upward in the direction of the arrow to remove them.

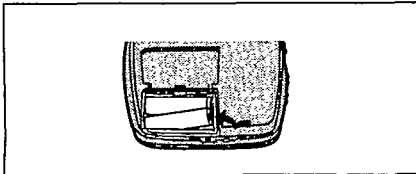

If the battery compartment lid becomes disengaged

Position it horizontally and press it back into position.

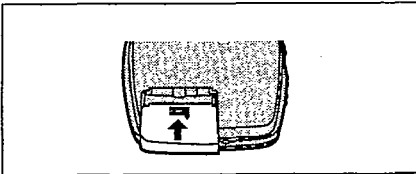

Using dry cell batteries (not included)

Disconnect the AC adaptor and then install two LR6 (UM-3) alkaline batteries.

The batteries are inserted and removed in the same way as for the rechargeable batteries.

To play for even longer durations

Disc play can be enjoyed for an even longer duration by using two additional size LR6 (UM-3) alkaline dry cell batteries.

1 Open the battery case lid, and insert the dry cell batteries.

Insert the ⊖ end first.

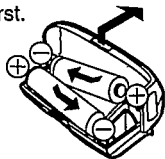

ACCIDENTAL OPERATION PREVENTION FUNCTION

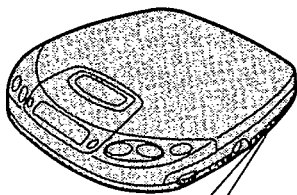

HOLD mode

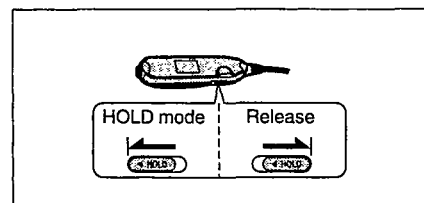
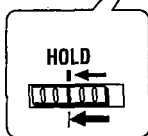

2 Attach the battery case to the player.

Align the protrusions on the case with the five cutouts in the player.

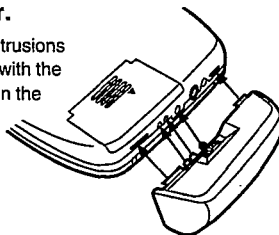

3 Lock the case into place using the screw.

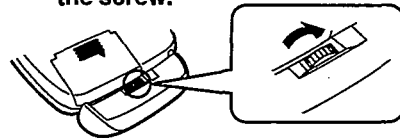

To disengage the case, follow the above procedure in reverse.

Notes

- Do not insert rechargeable batteries in the battery case.
- If rechargeable batteries and dry cell batteries are to be used at the same time, use fully charged rechargeable batteries and new dry cell batteries.
- If four dry cell batteries are to be used, do not use old and new batteries at the same time.

For your reference:

- The player can be powered by the batteries in the battery case alone no batteries need to be loaded in the player.
- The play time differs according to the type of batteries (rechargeable or dry) which are loaded in the player.

If the battery case lid becomes disengaged:

Fit the cutouts on both sides of the battery case lid over the protrusions on the case.

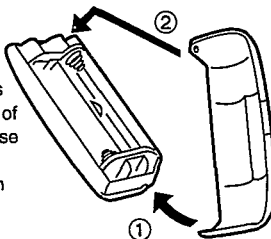

Battery indicator



This starts flashing when the batteries have run down, and after a short while the power is automatically cut off.

(The amount of time during which play continues after the indicator has started flashing differs slightly depending on the type of batteries used.)

Type of battery	Action
Rechargeable batteries	Recharge the batteries again.
Dry cell batteries	Replace with new batteries.

(The battery indicator may not flash if rechargeable batteries, other than those designated by our company, are used.)

Using the AC adaptor

Connect the AC adaptor supplied. Refer to the section on "Using rechargeable batteries" for details on the connections.

Using the car adaptor (not included)

Be sure to obtain the car adaptor (SH-CDC9), available as an optional accessory.

The batteries can be recharged inside the car using the car adaptor.

"hold" / "HOLD" indicator

[Unit]

If the unit is in the hold mode, the "hold" indicator appears when any of the unit's function buttons (except OPEN) is pressed.

When the unit is turned off

The "hold" indicator appears only when ► II is pressed.

[Wired remote controller]

The HOLD indicator appears when the wired remote controller is set to the hold mode.

[In the off mode (see pages 4 and 8), the HOLD indicator appears only when Play/stop/off button is pressed.]

Before operating the buttons

Be absolutely sure to move HOLD to release the unit from the hold mode.

To use the accidental operation prevention function

Set HOLD to the HOLD position.

The unit and the wired remote controller has a HOLD switch, each of which works independently.

SEQUENTIAL PLAY

1 Press OPEN to open the lid, and insert the disc.

Label must face upward.
Press the area near the center hole of the disc until it clicks into position.
Close the lid.

2 Release the hold mode.

3 Set MODE to NORMAL.

4 Connect the stereo earphones/wired remote controller to the jack.
(Plug in firmly)

5 Press ►||.
Play now starts.
Track number in play
Elapsed playing time of each track

6 Adjust the volume level.
(If the unit has been connected to the car audio system, adjust the volume level between 4 and 6 on the unit, then adjust the volume level on the system.)

Operation	Button	Display
Pause: Press during play/press again to resume play	►	7 0:18
To stop play: Press during play Stop mode	■	Total number of tracks 10 44:48 Total playing time
To turn off the unit: Press during stop mode Off mode	■	
Skip forward/backward (skip function): Press during play Rapid forward/backward (search function): Keep depressed during play.	►►: Forward direction ◄◄: Backward direction	—

Skip and search functions

- During program play (see page 6) the tracks are skipped in the forward or backward direction in the programmed sequence.
- During program play, random play or 1-track repeat play (see page 6), only the track being played is searched.
- During random play, it is not possible to skip to the track which has already been played.

For your reference:

"no disc" display

This appears for about 30 seconds when a disc has not been inserted or when a disc has not been inserted properly and then ►|| is pressed.

"open" display

This appears for about 10 minutes after the lid is opened. (It does not appear when the unit is turned off.)

Removing the disc

After the disc has stopped rotating, press PUSH and release the disc. (Do not open the lid during play.)

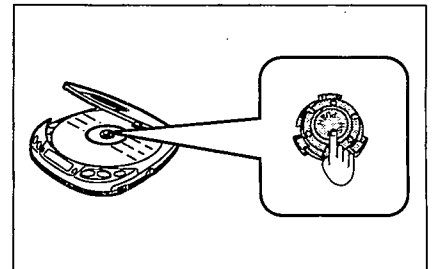

Note

Do not put anything inside the unit.

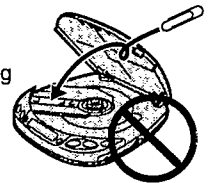

Automatic Shut-OFF function

When the unit is left for about 10 minutes in the stop or pause mode, this function automatically shuts off the power in order to prevent the batteries, etc. from discharging needlessly.

■ USING THE WIRED REMOTE CONTROLLER

The wired remote controller can be operated regardless of the hold mode of the unit.

Preparation:

Release the remote controller from the hold mode.

To adjust the volume

When adjusting the volume using the remote controller, position the volume control on the unit to between 4 and 6.

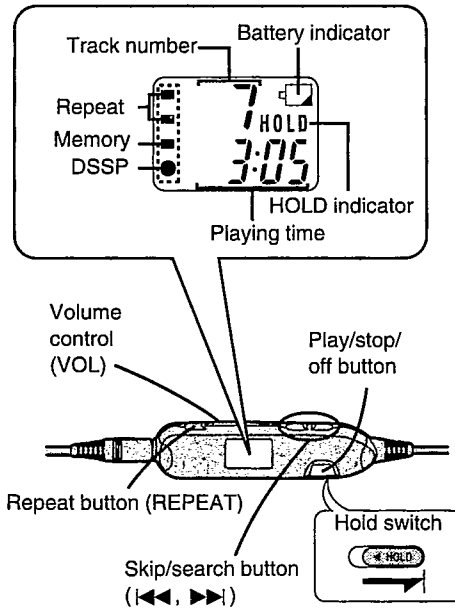

How to use the wired remote controller

How to use the play/stop/off button

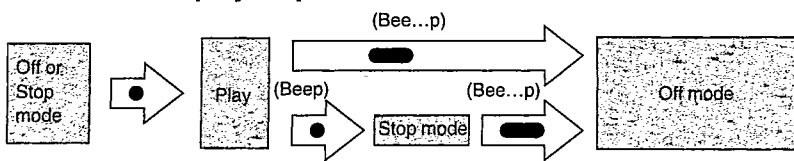

Parentheses represent confirmations tones.

- Press once.
- ▬ Press and hold.

An operations tone ("Beep") sounds whenever the remote controller button is pressed. In addition, a confirmation tone sounds following every operation.

How to use the skip/search buttons (|<< and >>|)

- Skip forward/backward:** Press during play.
- Rapid forward/backward:** Keep depressed during play.
- Listening from a desired track:** Press during stop mode to select a desired track, and then press play/stop/off button.

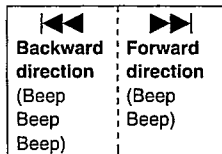

How to use the repeat button

Operation is the same as for the same button on the unit. (Except a beep is heard when a key is operated.)

Each time you press REPEAT, the repeat function will change as follows.

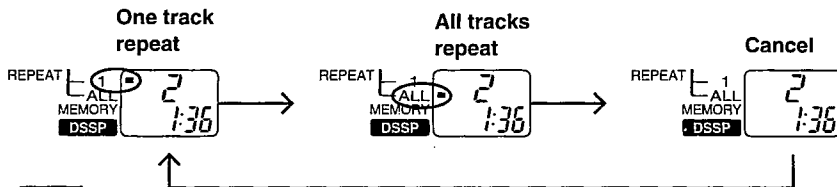

Note

When the repeat button is operated, the sound will be interrupted for an instant. This is normal and not indicative of a malfunction.

For you reference:

When the unit is in the programmed play mode.



When the unit's DSSP switch is ON.



■ USING THE UNIT WITH OPTIONAL ACCESSORIES

Using the unit with an audio system

Using the stereo connection cable (not included), you can hear CDs on your audio system.

- Connect the cable to the amplifier after turning off its power.
- Do not connect the cable to the PHONO jacks on the amplifier.
- Obtain the optional connecting cable if the amplifier comes with mini-phone jacks.
- Adjust the volume level on the amplifier.

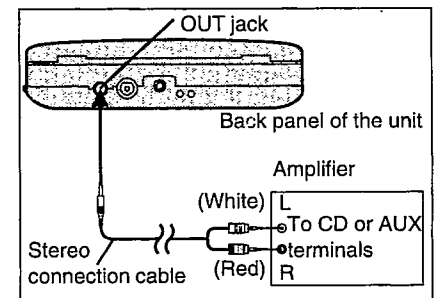

Using the unit with a car stereo

Items to be purchased

- For connection to the car audio system:** Car stereo cassette adaptor (SH-CDM9A)
- For securing the unit and connecting the power supply:**
 - Car adaptor (SH-CDC9)
 - Car mounting kit (SH-CDF7)
 - Car mounting arm, Car mounting base

Note

It may not be possible to use the unit with some types of car stereos owing to restrictions imposed by the construction of the car stereo cassette adaptor or car mounting kit.

For further details, refer to the instructions of the part concerned.

■ HANDLING PRECAUTIONS FOR TRAVERSE DECK

The laser diode in the traverse deck (optical pickup) may break down due to potential difference caused by static electricity of clothes or human body.

So, be careful of electrostatic breakdown during repair of the traverse deck (optical pickup).

● Handling of traverse deck (optical pickup)

1. Do not subject the traverse deck (optical pickup) to static electricity as it is extremely sensitive to electrical shock.
2. The short land between the No. ⑬ (LD) and No. ⑫ (GND) pins on the flexible board (FFC) is shorted with a solder build-up to prevent damage to the laser diode. To connect to the PC board, be sure to open by removing the solder build-up, and finish the work quickly.
3. Take care not to apply excessive stress to the flexible board (FFC).
4. Do not turn the variable resistor (laser power adjustment). It has already been adjusted.

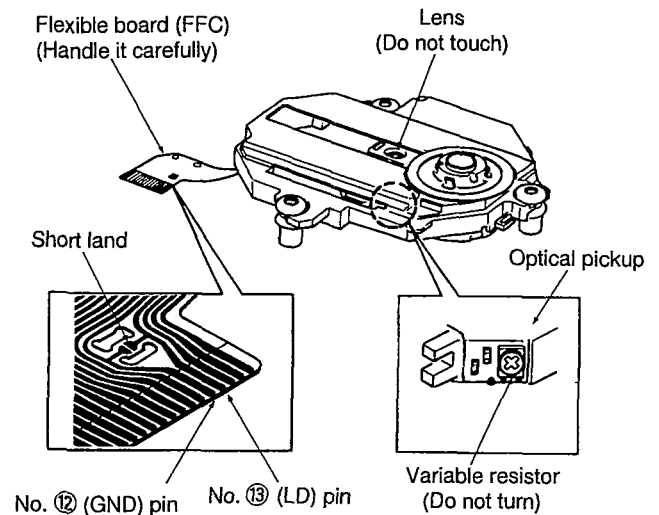

● Grounding for electrostatic breakdown prevention

1. **Human body grounding**
Use the anti-static wrist strap to discharge the static electricity from your body.
2. **Work table grounding**
Put a *conductive material (sheet) or steel sheet* on the area where the optical pickup is placed, and ground the sheet.

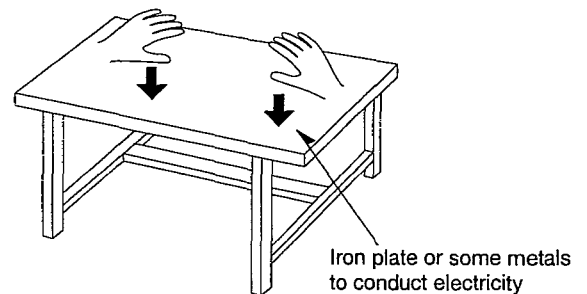
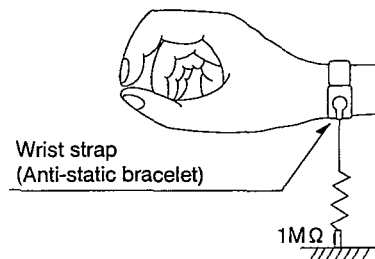

Caution:

The static electricity of your clothes will not be grounded through the wrist strap. So, take care not to let your clothes touch the traverse deck (optical pickup).

OPERATION CHECKS AND MAIN COMPONENT REPLACEMENT PROCEDURES

Warning: This product uses a laser diode. Refer to caution statements on page 2.

- NOTE**
1. This section describes procedures for checking the operation of the major printed circuit boards and replacing the main components.
 2. For reassembly after operation checks or replacement, reverse the respective procedures. Special reassembly procedures are described only when required.
 3. Illustrated screws are equivalent to actual size.
 4. [] indicates parts No.

1. Checking for the P.C.B.

Step 3

Lift up the intermediate cabinet ass'y

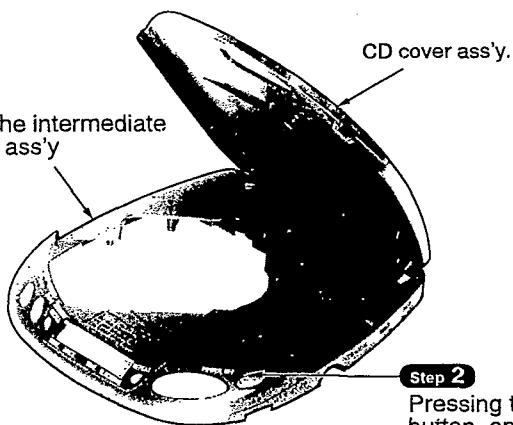

Step 2

Pressing the OPEN button, open the CD cover ass'y.

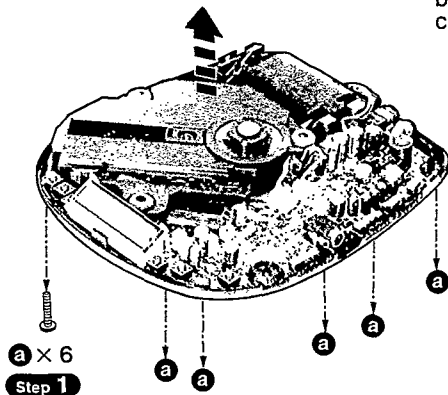

a x 6
Step 1

Things to be careful about when connecting the terminal for battery case:

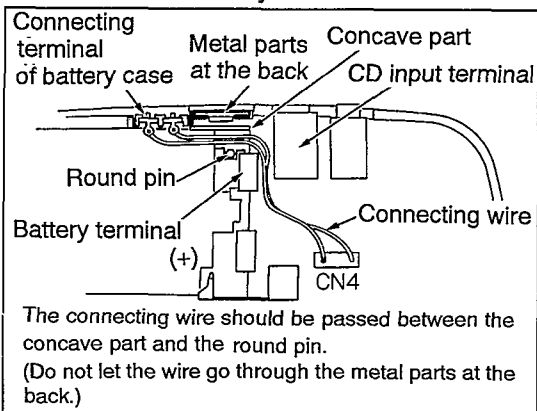

Step 4

1. Remove the 4 switch knobs.

Step 4

2. Remove the battery case.

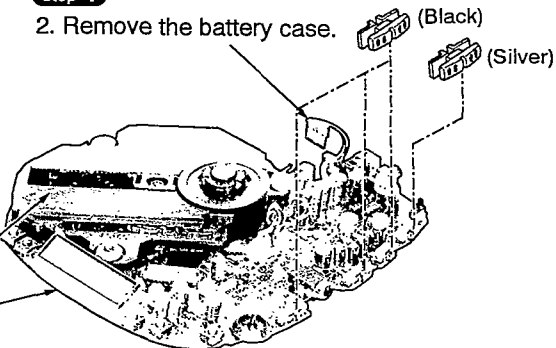

Step 5

Remove the traverse deck and P.C.B..

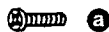
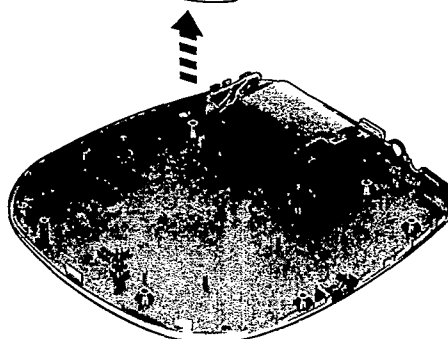

[XTN17+6GFZ] (Black)

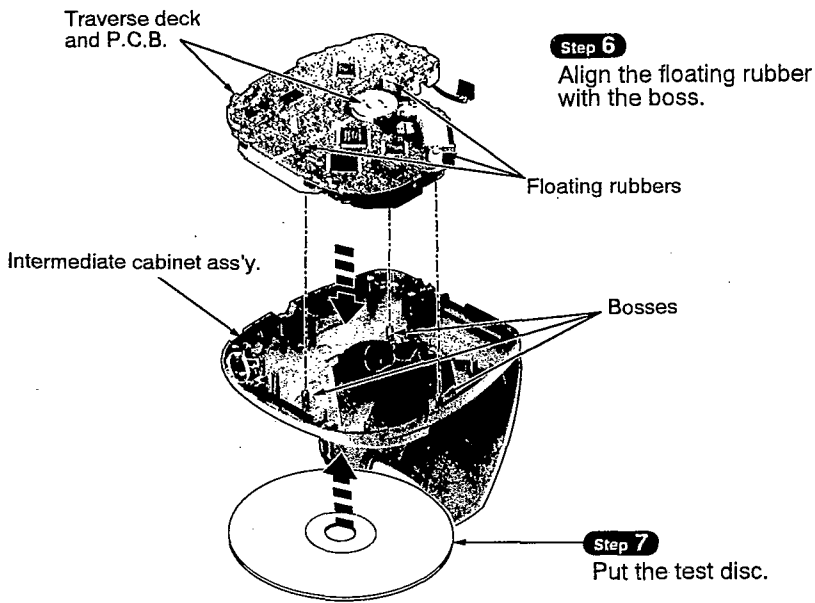

• Check the P.C.B. (Solder side) as shown below.

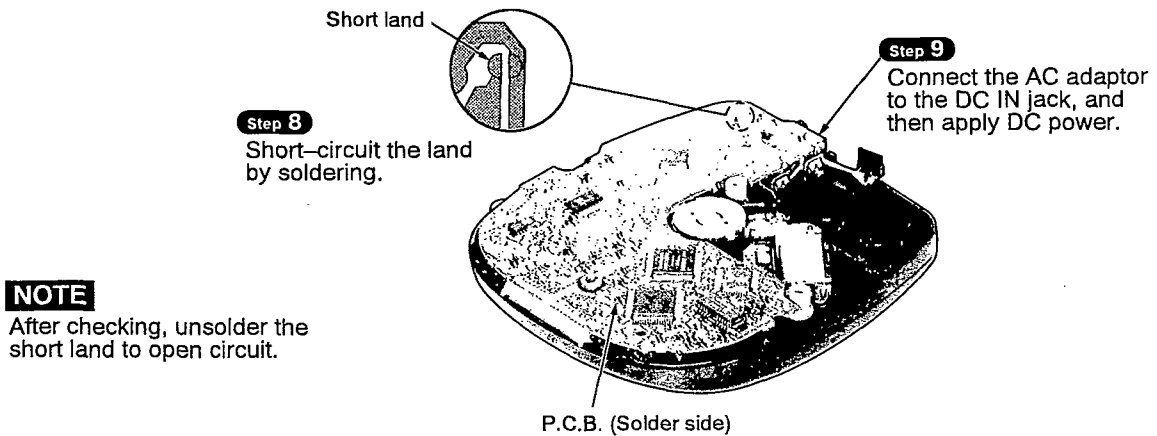

2. Replacement for the traverse deck

• Follow the **Step 1** ~ **Step 3** in item 1.

NOTE

Solder the point between pin 4 (LD) and pin 5 (GND) of FFC board.
(Refer to "Handling Precautions for Traverse Deck" on page 7.)

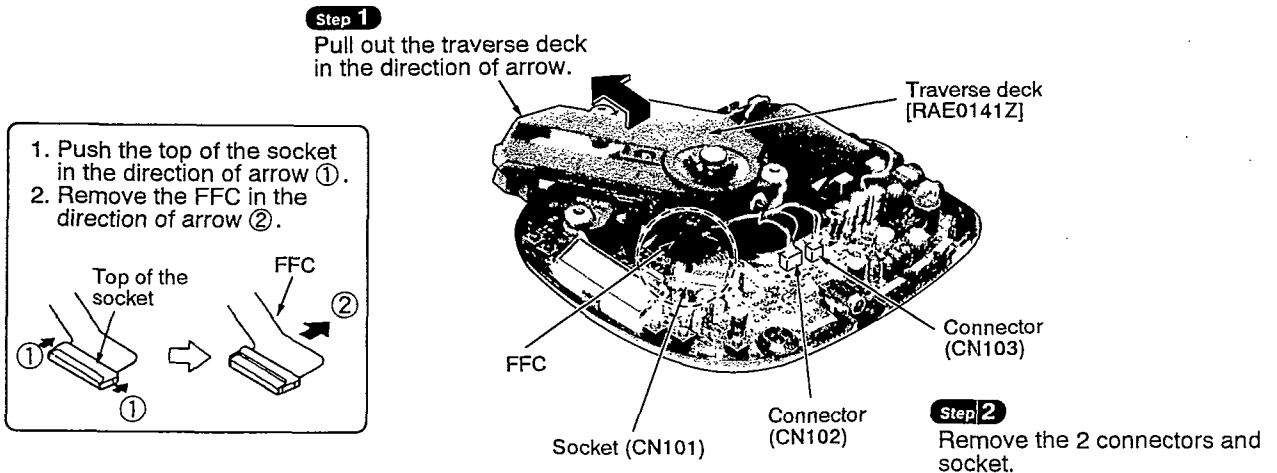

3. Replacement for the CD cover ass'y

• Follow the **Step 1** ~ **Step 3** in item 1.

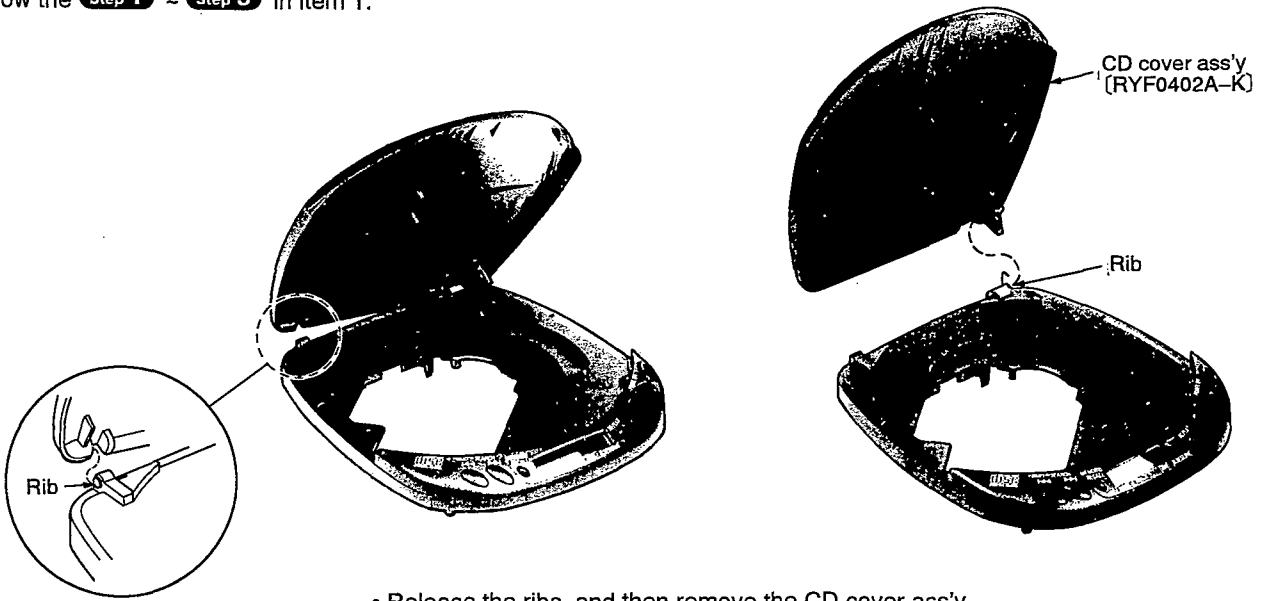

• Release the ribs, and then remove the CD cover ass'y.

• Terminal guide of IC's, transistors and diodes

<table border="1"> <tr> <td>NJU7082AMTE1</td> <td>8PIN</td> </tr> <tr> <td>AN8837SBE1</td> <td>28PIN</td> </tr> </table> <p>No.1</p>	NJU7082AMTE1	8PIN	AN8837SBE1	28PIN	<table border="1"> <tr> <td>AN8788FB</td> <td>44PIN</td> </tr> <tr> <td>SM5856A1F</td> <td>44PIN</td> </tr> <tr> <td>MN662745RPC</td> <td>80PIN</td> </tr> </table> <p>No.1</p>	AN8788FB	44PIN	SM5856A1F	44PIN	MN662745RPC	80PIN	<p>SC440301FU</p>	<p>LH6456K2</p>
NJU7082AMTE1	8PIN												
AN8837SBE1	28PIN												
AN8788FB	44PIN												
SM5856A1F	44PIN												
MN662745RPC	80PIN												
<p>FMW1T98 FMG4T148</p>	<p>2SD1450STTA</p>	<p>2SB1218QRSTX 2SB709QRSTX 2SB970RSTX 2SD1328RSTTX 2SD1819QRSTX DTA143TUT107 UN5113TX UN5114TX</p>	<p>UN5211TX UN5213TX UN5215TX</p> <p>2SD2074HWRST</p>										
<p>MA8047MTX MA8051MTX</p>	<p>1SS355TE17</p>	<p>SS14G11</p>	<p>MA151WKTX</p>										

■ CHECKING THE OPERATION PROBLEMS ON THE TRAVERSE DECK (OPTICAL PICKUP)

Make sure to follow the procedures below to check the operation problems of the traverse deck (optical pickup) before replacing it. Replace the traverse deck only after the problem is identified.

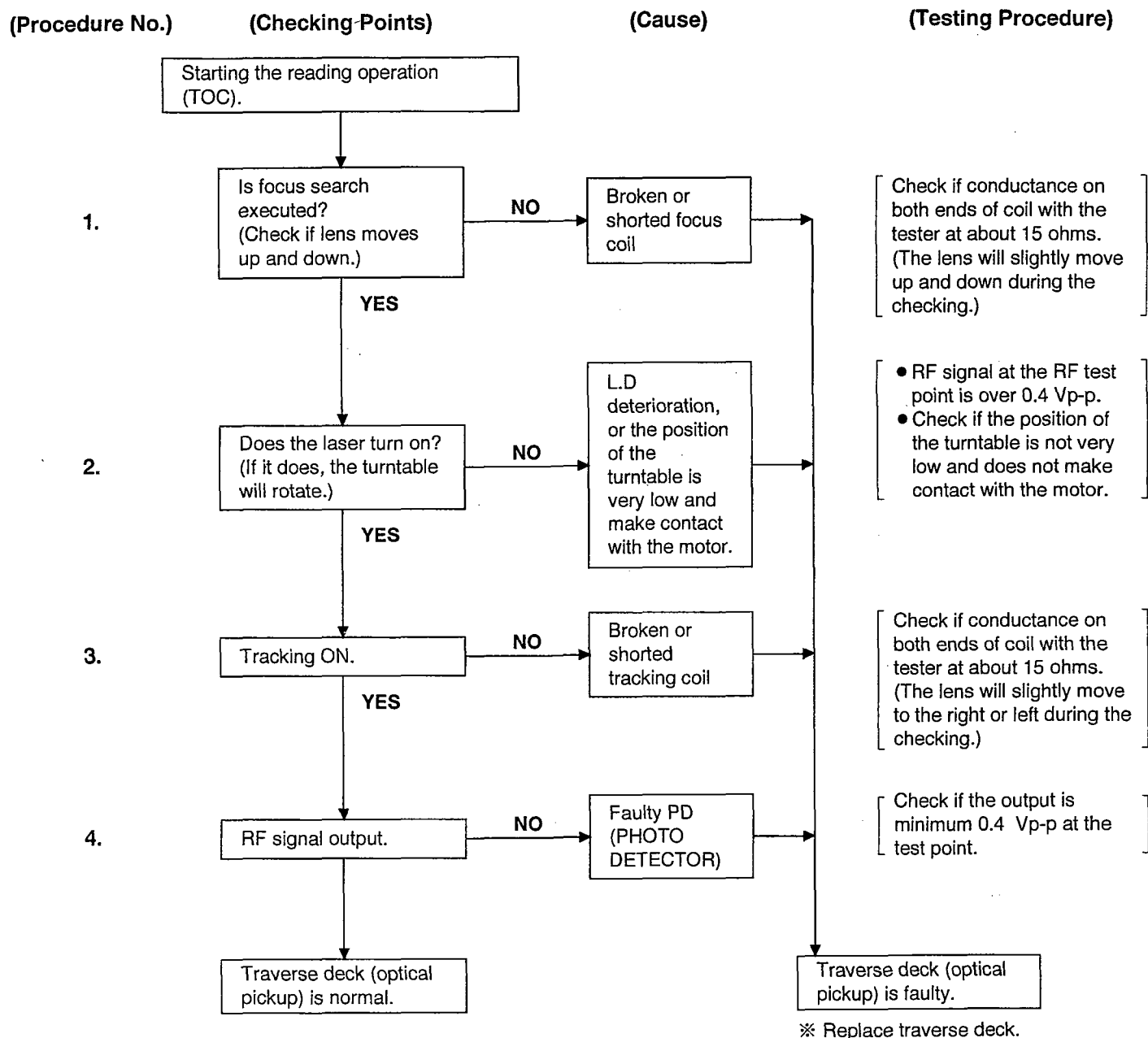

- Check electrical circuit.
- Check for flaws on disc or if it is warped or not centered.

• Check the operations described below on the traverse deck after replacing it.

* Checking Skip Search

1. Play an ordinary musical program disc.
2. Press the skip button to check for normal skip search operation (in both the forward and reverse directions).

* Checking Manual Search

1. Play an ordinary musical program disc.
2. Press the manual search button to check for smooth manual search operations at either low or high speed (in both the forward and reverse directions).

* Checking Playability

1. Play the 0.7 mm black dot and the 0.7 mm wedge on the playability test disc (SZZP1054C) and verify that no sound skip or noise occurs.
2. Play the middle tracks of the uneven test disc (SZZP1056C) and verify that no sound skip or noise occurs.

■ AUTOMATIC ADJUSTMENT RESULTS DISPLAY FUNCTION (SELF-CHECK FUNCTION)

On this unit (SL-S240), each automatic adjustment result are displayed on the LCD. This function is convenient to check or identify which automatic adjustment circuit is incorrect. The followings are the contents of the automatic adjustment result displays (self-check function).

● How to display automatic adjustment results

1. Load the test disc (SZZP1054C).
2. Press the ◀◀ (SKIP/SEARCH) and ▶▶ (SKIP/SEARCH) Buttons simultaneously and hold them, and additionally press the ▶ / ⏸ (PLAY/PAUSE) Button.
3. Press the ■ (STOP/POWER OFF) Button once.
4. An automatic adjustment result is displayed on the LCD.

● Display of automatic adjustment results (self-check function)

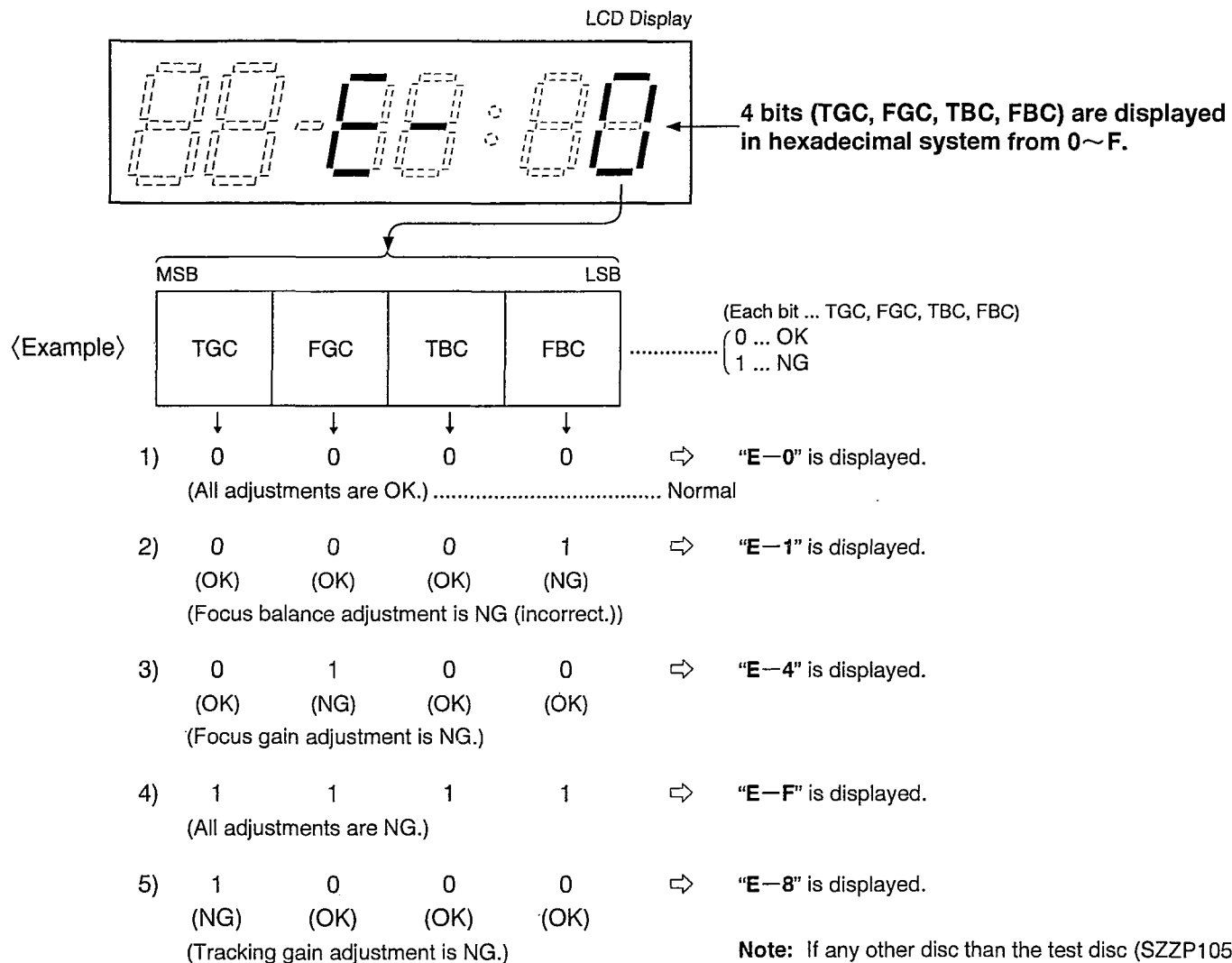

〈Example〉 Follow the below steps when "E-1" is displayed.

(Cause: Focus balance (FBC) is set beyond the limit.)

- Check if
 - (1) the waveform or voltage of the focus servo circuit is correct, and
 - (2) the optical pickup returns to the normal state by exchanging the traverse deck.

Follow the below steps when "E-4" is displayed.

(Cause: Focus gain (FGC) is set beyond the limit.)

- Check if
 - (1) the waveform or voltage of the focus servo circuit is correct,
 - (2) the focus coil of the optical pickup is correct (around 15 ohms), and
 - (3) the optical pickup returns to the normal state by exchanging the traverse deck.

Follow the below steps when "E-F" is displayed.

(Cause : All adjustments (TGC, FGC, TBC, FBC) are set beyond the limit.)

- Check if
 - (1) the optical pickup returns to the normal state by exchanging the traverse deck, and
 - (2) the waveform or voltage of the servo IC's (IC101, 501) are correct.

Note:

It is not always necessary to exchange the traverse deck when an error message is displayed.
Be sure to check if the circuit is defective or not before exchanging the traverse deck.

Note:

If any other disc than the test disc (SZZP1054C) is used, an error message may be displayed. This is not a malfunction.

MEASUREMENTS AND ADJUSTMENTS

Warning: This product uses a laser diode. Refer to caution statements on page 2.

Measuring instruments and special tools

● Test discs

1. Playability test disc (SZZP1054C)
2. Uneven test disc (SZZP1056C)

● Musical program disc (ordinary)

- DC voltmeter
- Lead wire (for test points)

Test short land

Short-circuit the lands of the laser ON/OFF switch (S201) by soldering them. It turns "ON" position. (Refer to below figure or printed circuit board and wiring connection diagram for short land location on page 24.)

Note: Remove the solders from the lands after adjustment.

Adjustment point

Notes: 1. Please refer to the printed circuit board and wiring connection diagram for test point locations.
2. Take care to connect CN101.

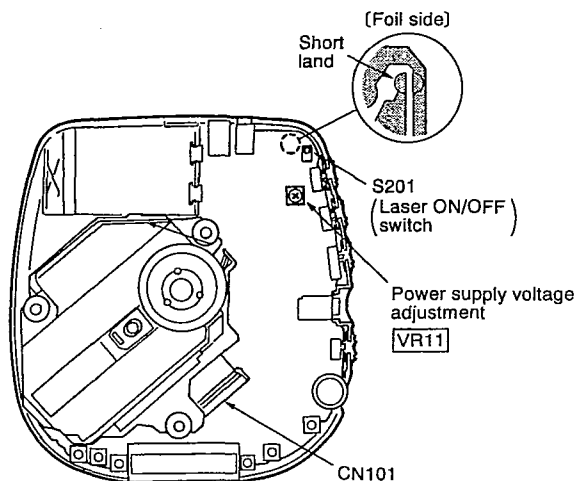

● Adjustment procedure

(1) POWER SUPPLY VOLTAGE ADJUSTMENT

1. Connect the DC voltmeter to **TP2** (VCC) (+) and **TP3** (GND) on the P.C.B.
2. Connect the AC adaptor cord to the DC (IN) port and move the PLAY switch to the ON position.
(Use a new dry cell battery or a rechargeable battery that is full charged.)
3. Insert the test disc, and switch the player power ON.
4. Adjust VR11 on the P.C.B. at 3.32 ± 0.02 V.

(2) CHECK OF PLAY OPERATION

* Checking Skip Search

1. Play an ordinary musical program disc.
2. Press the skip button to check for normal skip search operation (in both the forward and backward directions).

* Checking Manual Search

1. Play an ordinary musical program disc.
2. Press the manual search button to check for smooth manual search operations at either low or high speed (in both the forward and backward directions).

* Checking Playability

1. Play the 0.7 mm black dot and the 0.7 mm wedge on the playability test disc (SZZP1054C) and verify that no sound skip or noise occurs.
2. Play the middle tracks of the uneven test disc (SZZP1056C) and verify that no sound skip or noise occurs.

● Automatic adjustment

On our conventional type portable CD player, there were mounted 6 semi-fixed controls for each adjustment. Since the SL-S270 servo circuit is equipped with an automatic adjusting circuit, these controls are removed from SL-S270.

On conventional portable CD player Use for Old Servo IC (AN8373SE2, AN8374SE2)	➔	On SL-S270 Use for New Servo IC (AN8837SBE1, MN662745RPC)
1. Tracking Offset Adjustment VR (TOC) <input type="checkbox"/>	➔	Non Adjustment
2. Focus Offset Adjustment VR (FOC) <input type="checkbox"/>	➔	Automatic Adjusting Circuit
3. Tracking Gain Adjustment VR (TGC) <input type="checkbox"/>	➔	
4. Focus Gain Adjustment VR (FGC) <input type="checkbox"/>	➔	
5. Tracking Balance Adjustment VR (TBC) <input type="checkbox"/>	➔	
6. Focus Balance Adjustment VR (FBC) <input type="checkbox"/>	➔	
Total 6 Adjustment VRs		➔ No Adjustment VR

Although all discs are manufactured according to the same specifications, their characteristics are not always precisely the same because they are produced by different manufacturers in various lots, or have different warp etc.

SL-S270 automatically controls the servo circuit to obtain optimum performance according to any disc's characteristics.

Therefore, no malfunction occurs because of mis-adjustment.

BLOCK DIAGRAM

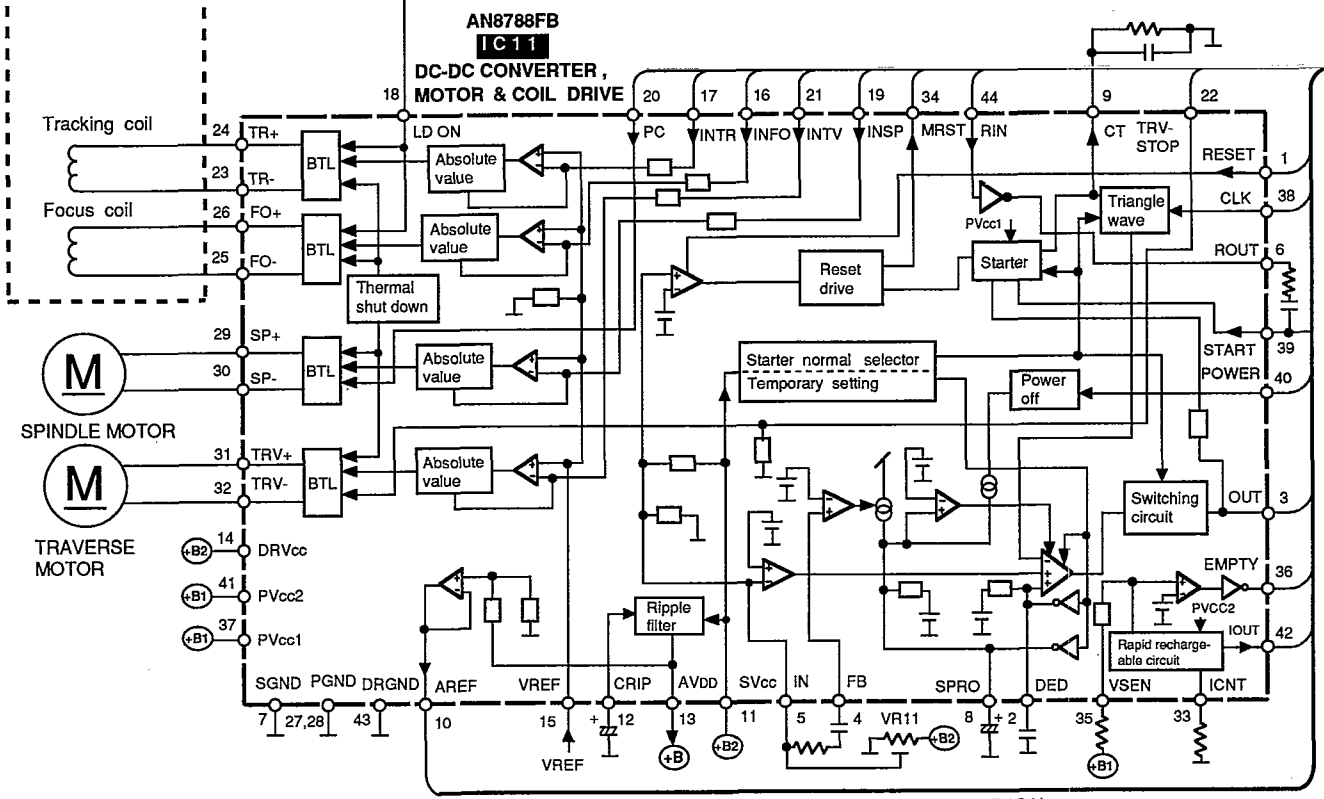
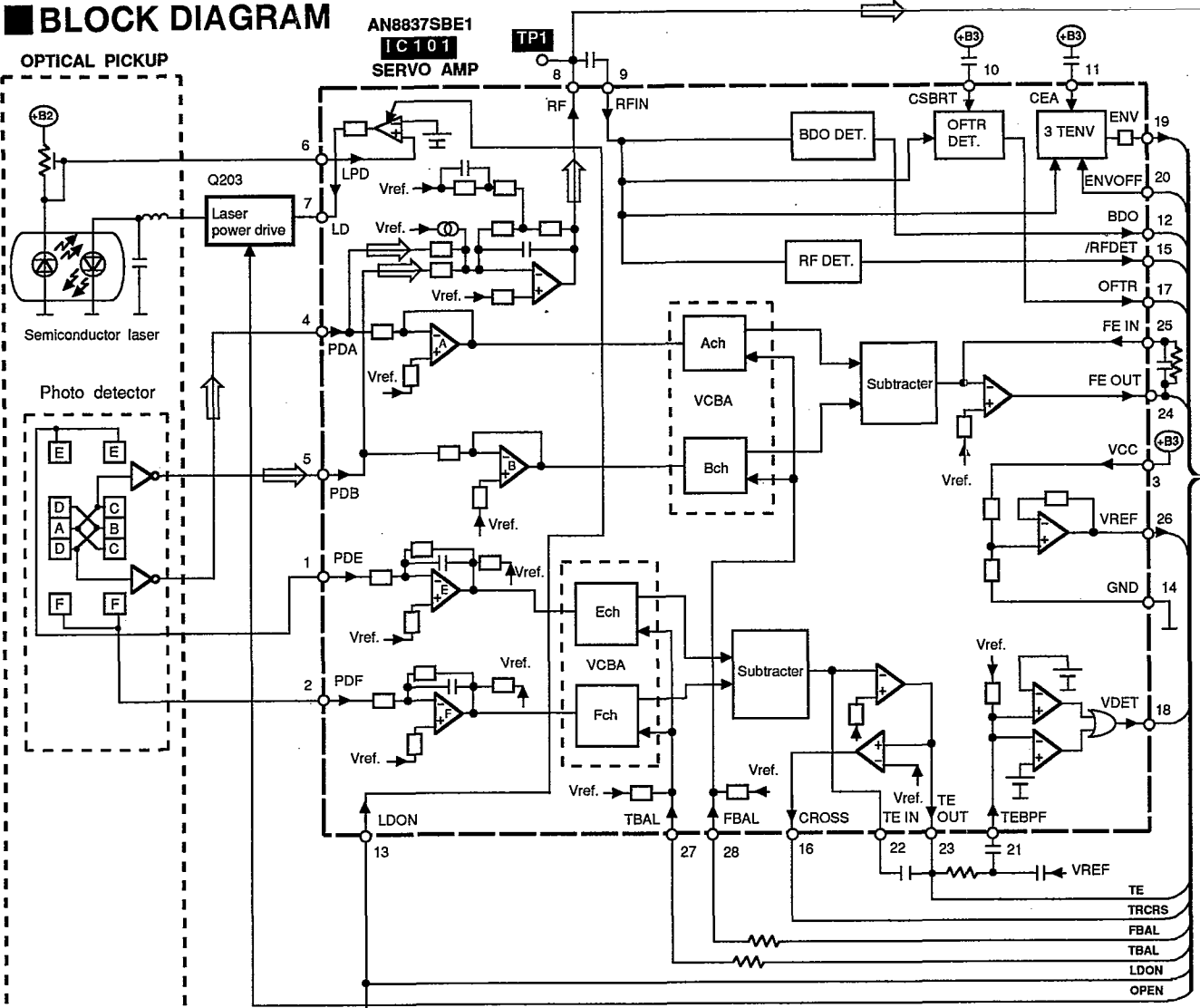

● Signal line ➡ : Audio signal

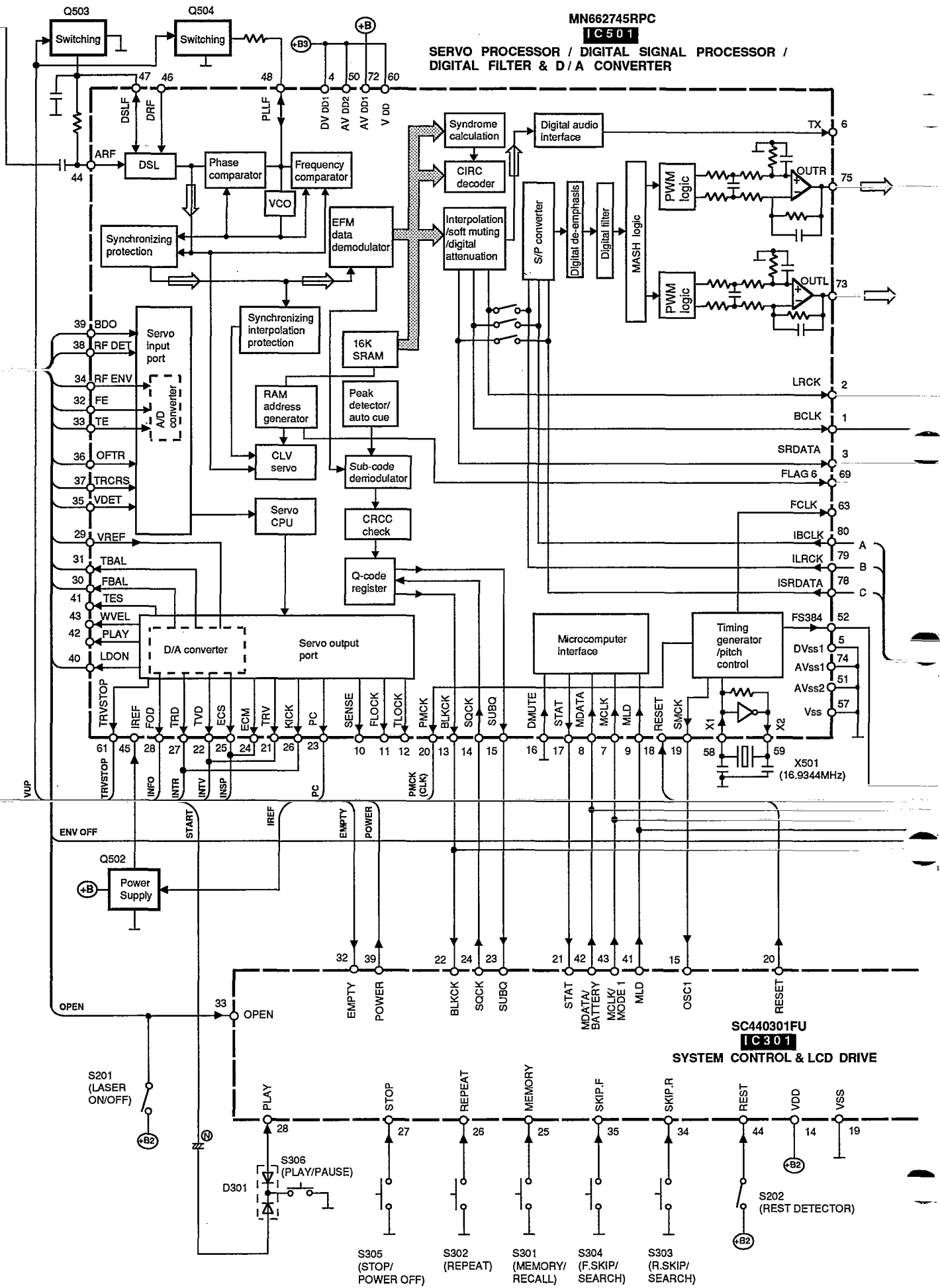

● Signal line ⇨ : Audio signal

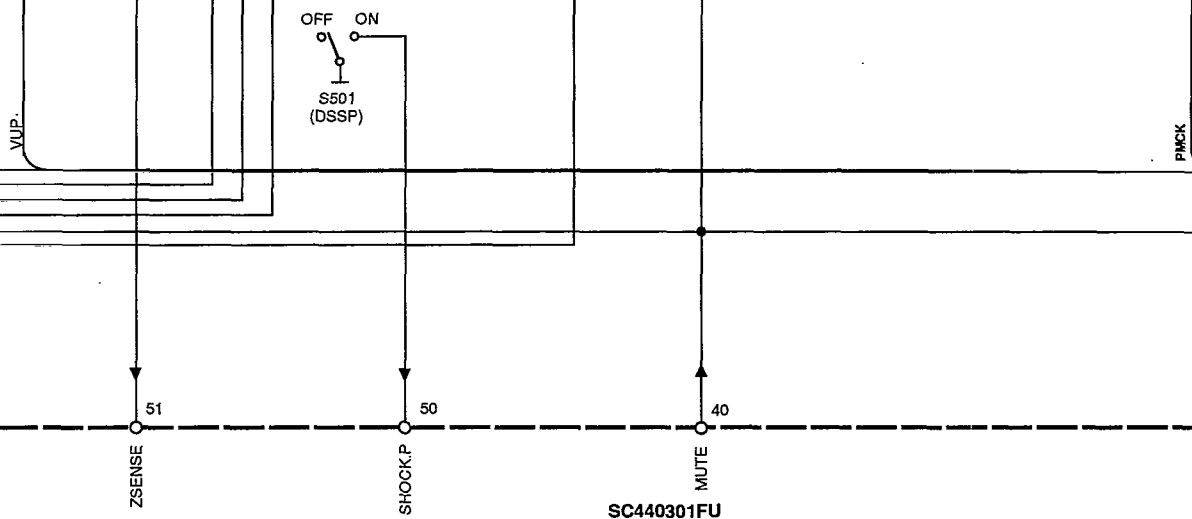
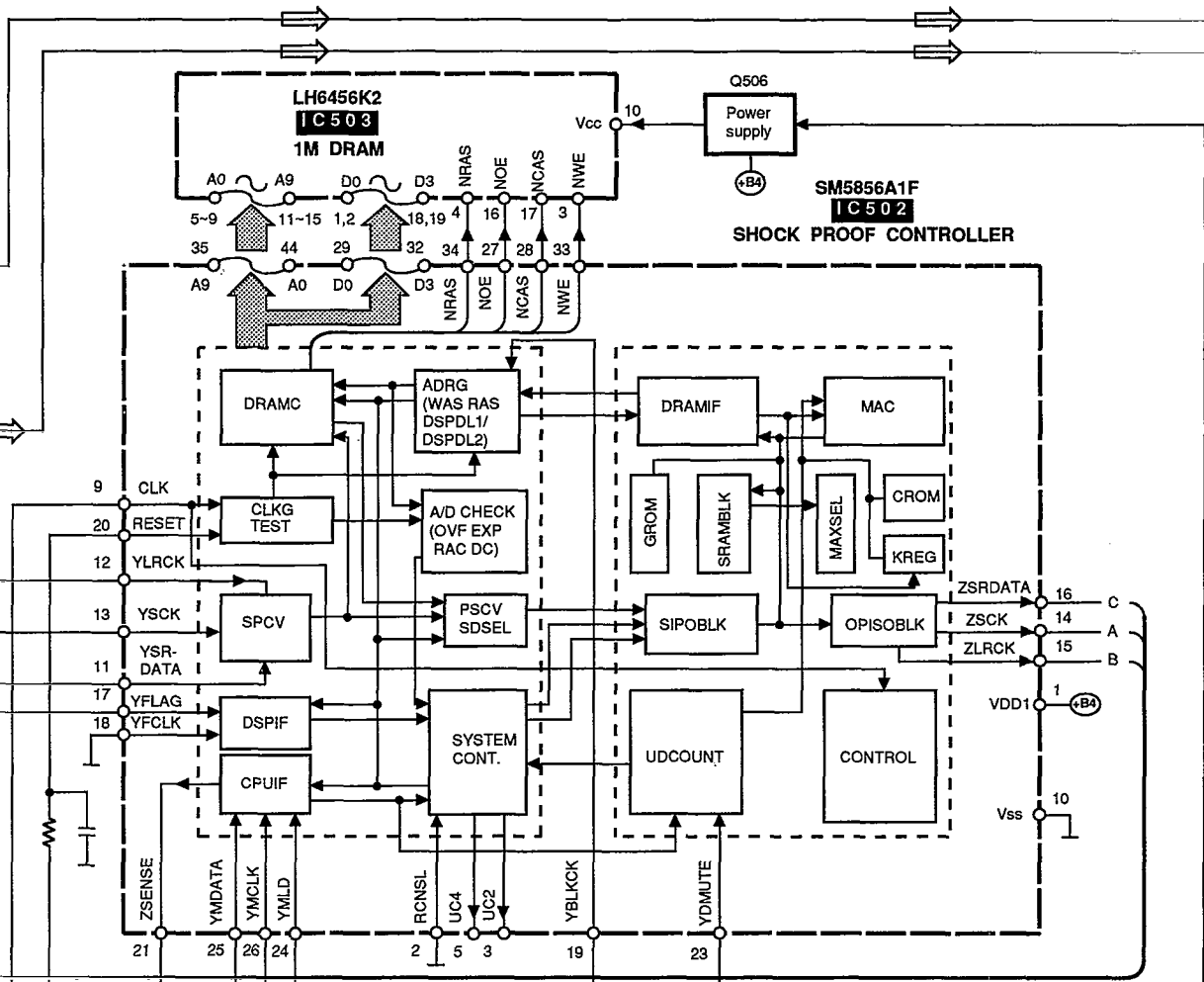

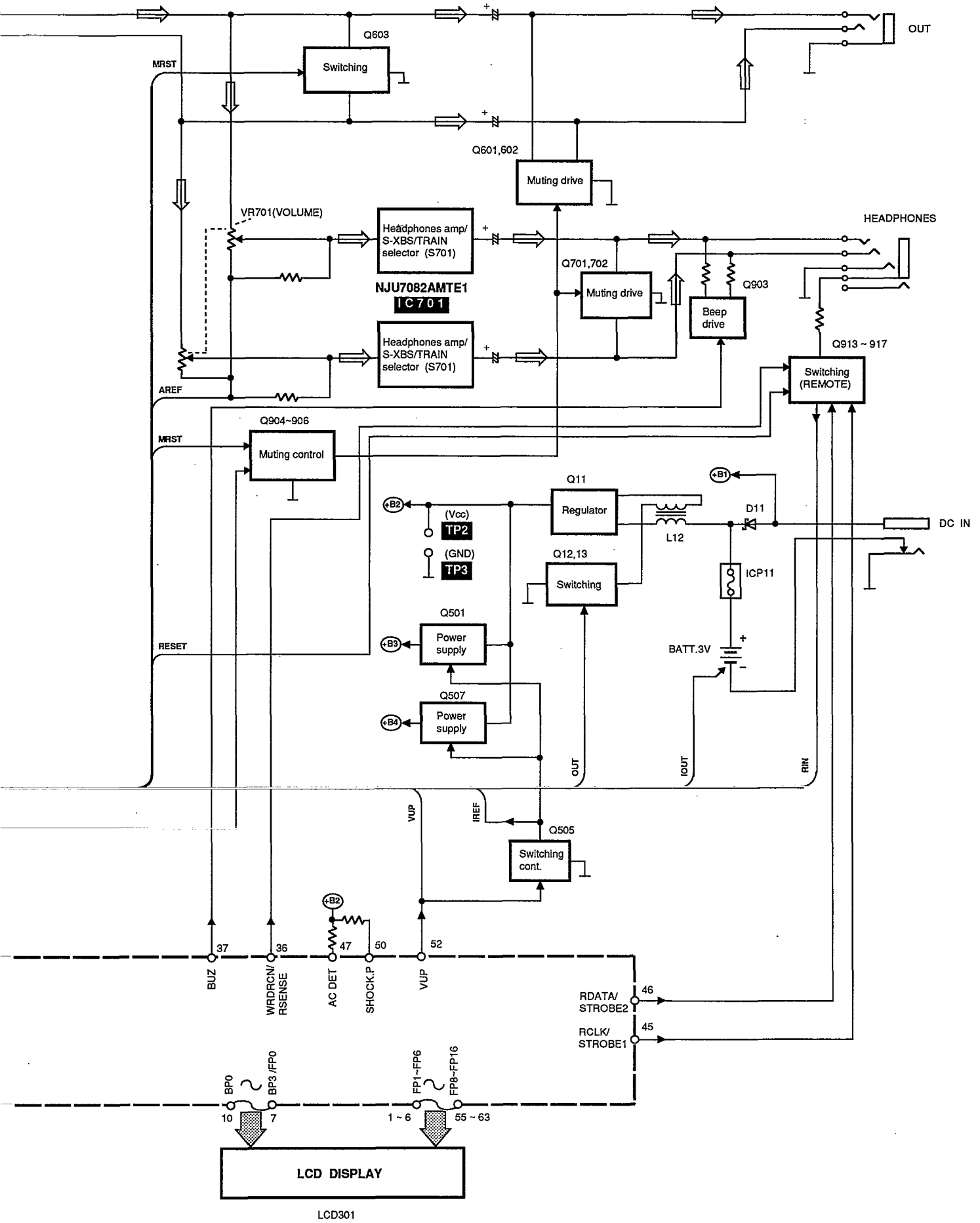

■ SCHEMATIC DIAGRAM (See parts list on pages 33 ~ 35)

(This schematic diagram may be modified at any time with the development of new technology.)

Notes:

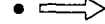
- **S201:** Laser ON/OFF switch in "OFF" position.
(It turns "ON" with disc holder closed.)
- **S202:** Rest detector in "OFF" position.
(It turns "ON" when optical pickup comes to innermost periphery.)
- **S301:** Memory/recall (MEMORY/RECALL) switch.
- **S302:** Repeat (REPEAT) switch.
- **S303, 304:** Skip/search (◀◀-SKIP/-SEARCH ▶▶) switches.
(S303: ◀◀, S304: ▶▶)
- **S305:** Stop/power off (■ POWER OFF) switch.
- **S306:** Play/pause (▶ ||) switch.
- **S307:** Play mode selector (MODE) in "RANDOM" position.
(RANDOM↔NORMAL↔RESUME)
- **S308:** Hold (HOLD) switch in "ON" position.
- **S501:** Anti-shock (ANTI-SHOCK) switch.
- **S701:** XBS selector in "ON" position.
- The voltage value and waveforms are the reference voltage of this measured by DC electronic voltmeter (high impedance) and oscilloscope on the basis of GND terminal (DC IN Jack). Accordingly, there may arise some errors in the voltage values and waveforms depending upon the internal impedance of the tester or measuring unit.
* The parenthesized is the voltage for test disc (1 kHz, L+R, 0 dB) in play mode, and the other, for no disc in stop mode.
* AC adaptor is used for power supply.
-  : Positive voltage lines.
-  : Audio signal lines.
- Important safety notice:
Components identified by Δ mark have special characteristics important for safety. Furthermore, special parts which have purposes of fire-retardant (resistors), high-quality sound (capacitors), low-noise (resistors), etc. are used. When replacing any of components, be sure to use only manufacture's specified parts shown in the parts list.
- ※marks indicate printed resistor.

Caution!

IC and LSI are sensitive to static electricity.

Secondary trouble can be prevented by taking care during repair.

- Cover the parts boxes made of plastics with aluminum foil.
- Ground the soldering iron.
- Put a conductive mat on the work table.
- Do not touch the pins of IC or LSI with fingers directly.

• \rightarrow : Audio signal lines.

(P.C.Board: on page 24)

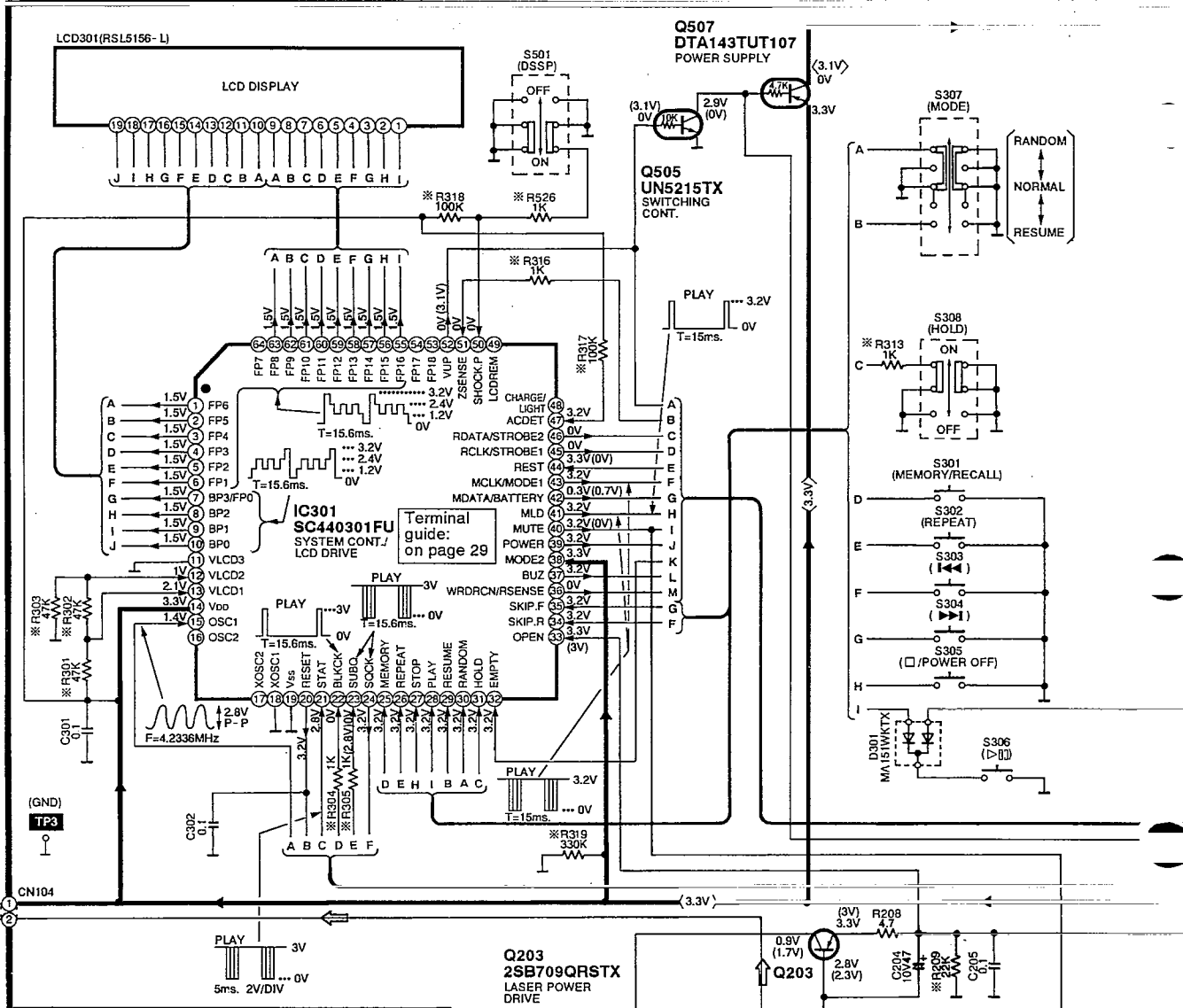

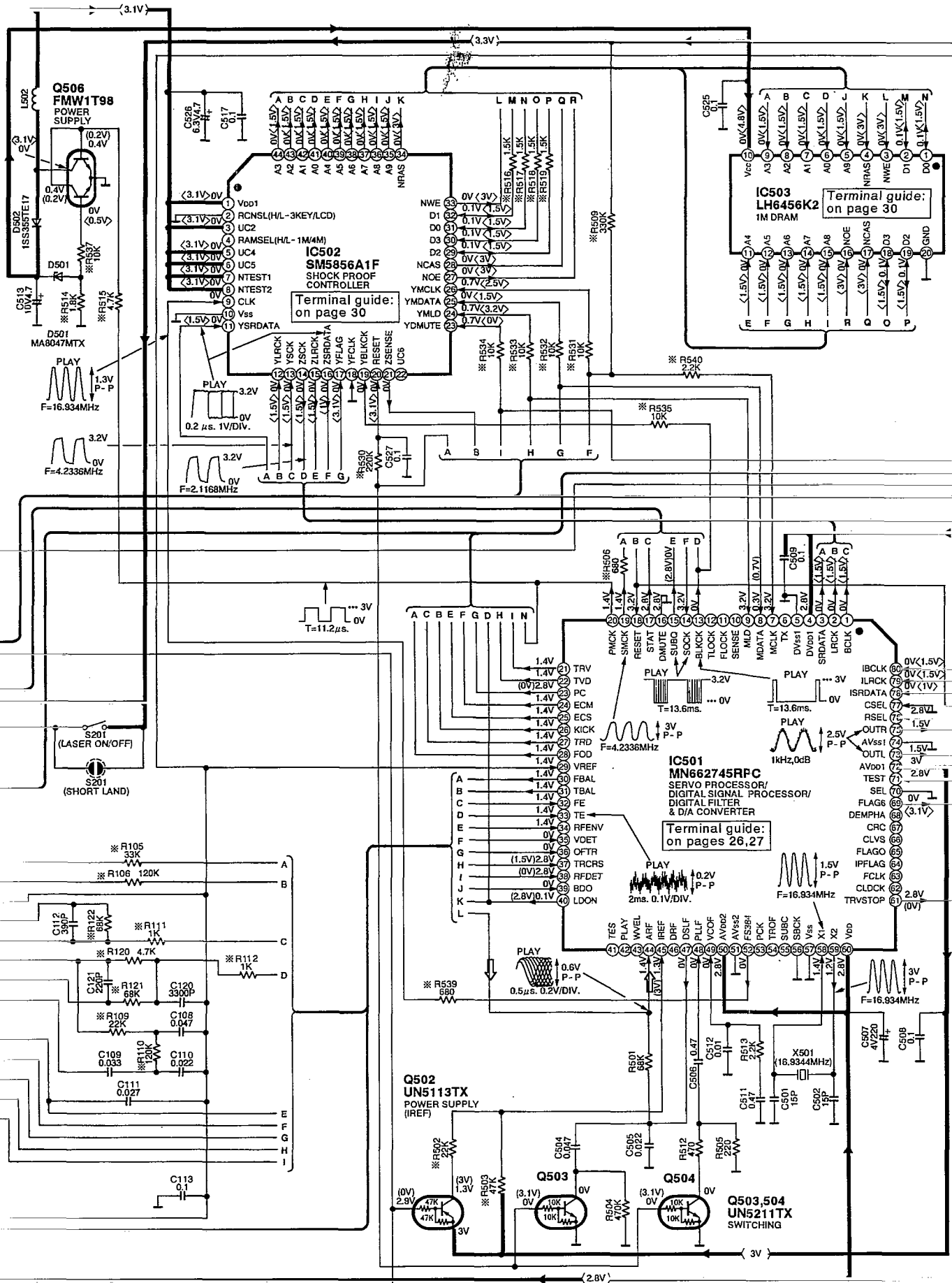

• → : Audio signal lines.

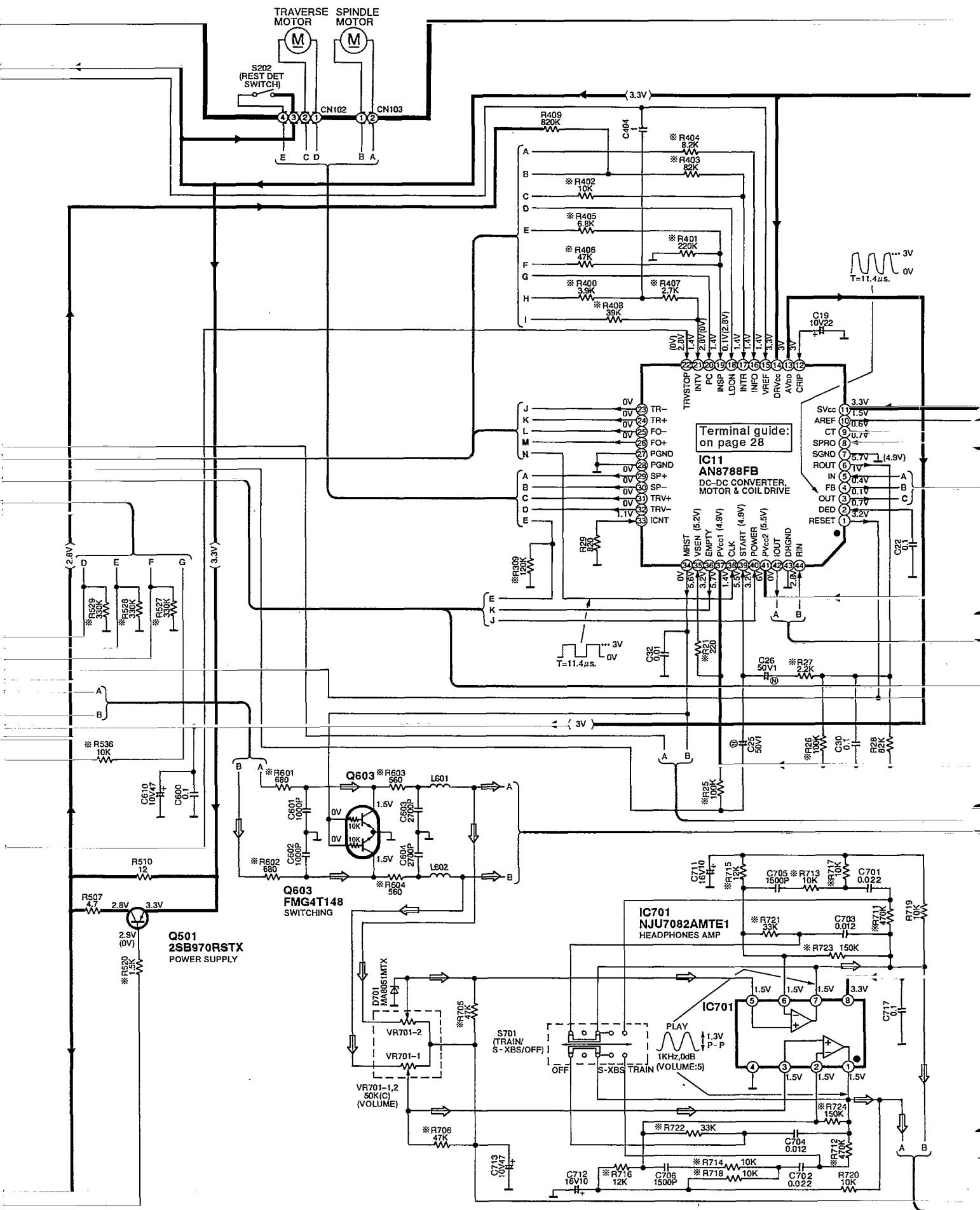

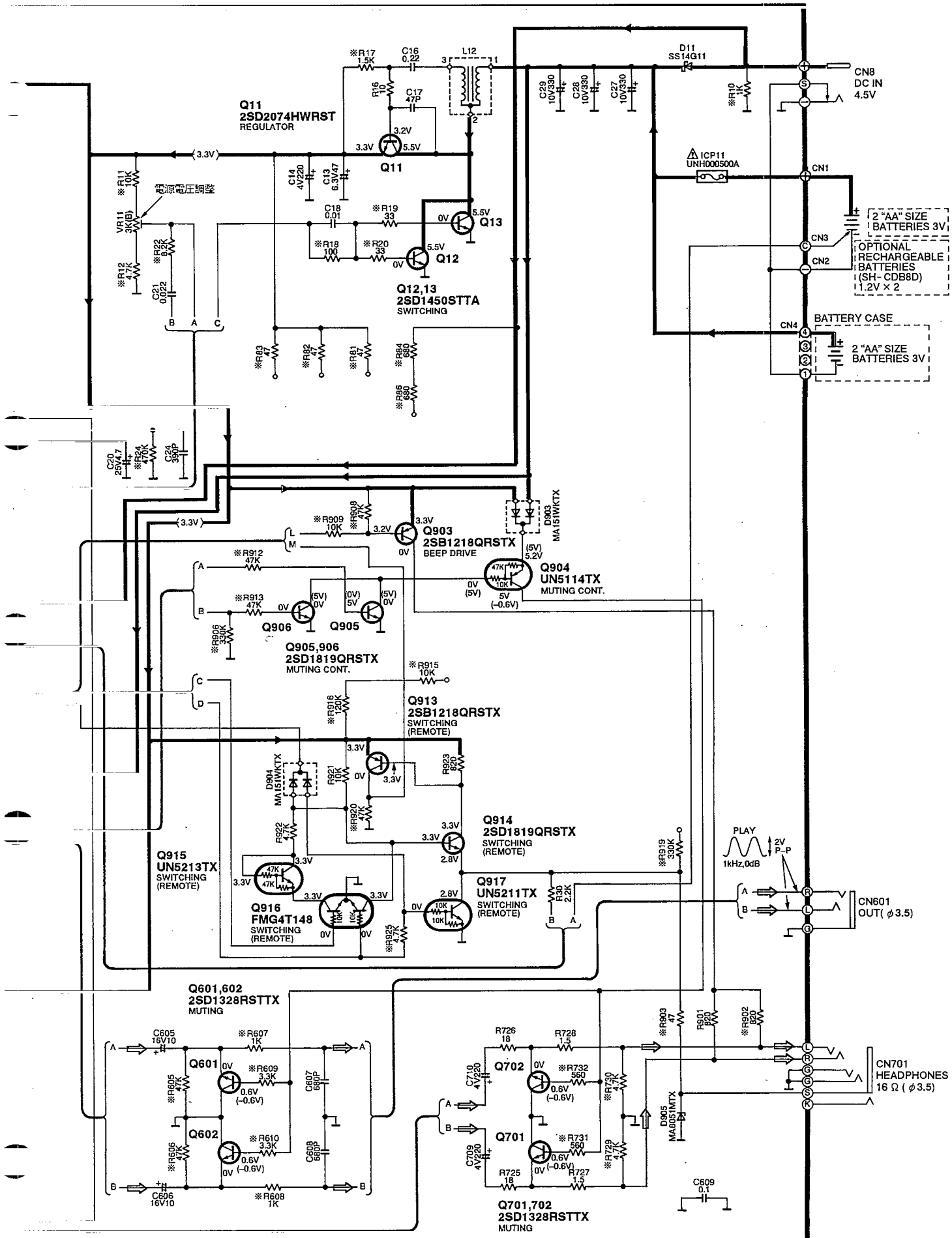

PRINTED CIRCUIT BOARD AND WIRING CONNECTION DIAGRAM

Notes:

- In this printed circuit board diagram, the parts and foil patterns on the board facing toward you are printed in black. The opposite side is printed in blue.
- The "●" mark denotes the connection points of double-faced foil patterns (through holes) on both sides of the printed circuit board.
- This printed circuit board diagram may be modified at any time with the development of new technology.

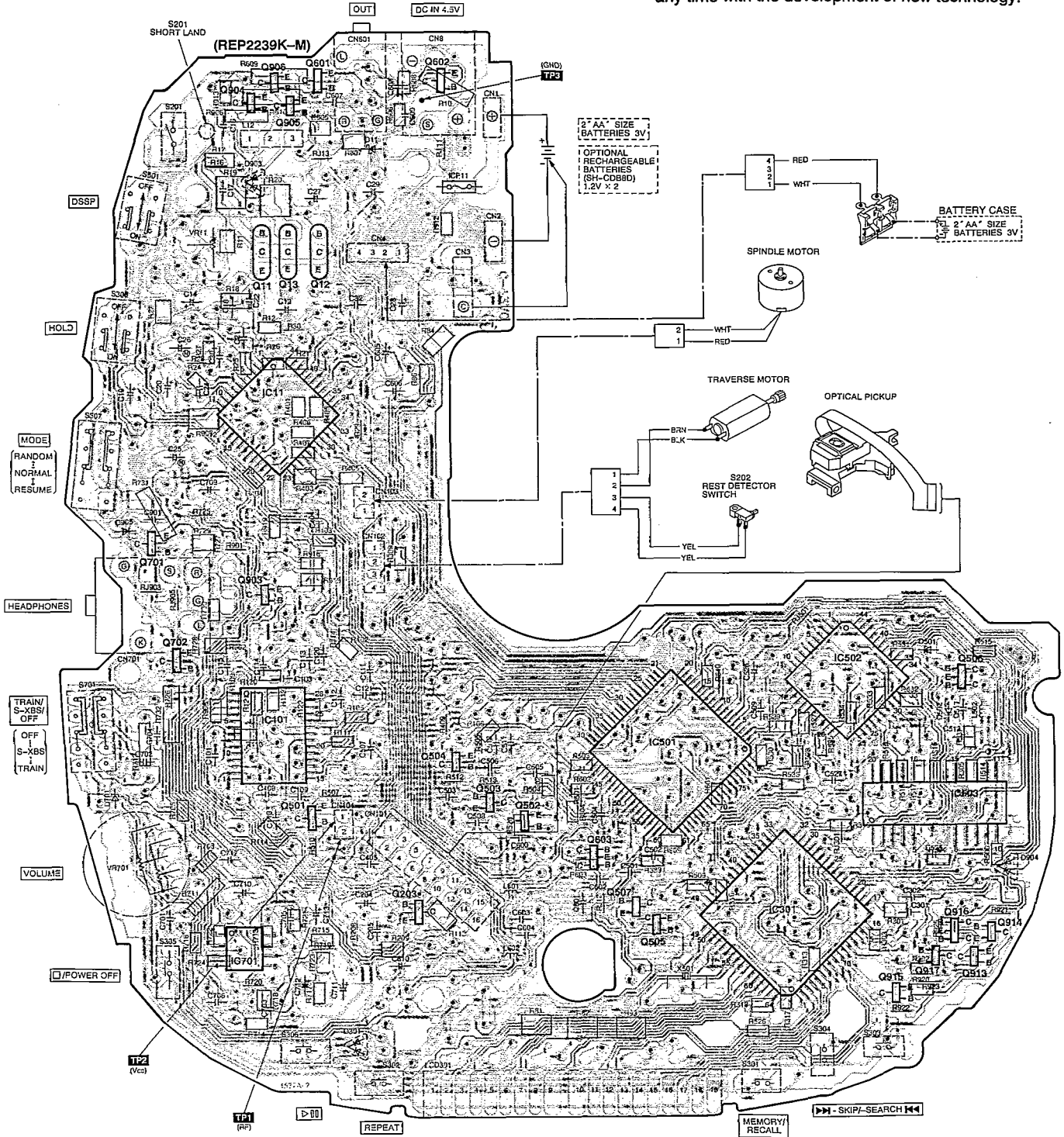

REPAIRING THE PRINTED RESISTOR

This unit uses a printed resistor for the printed circuit board. If the printed resistor is insulated, all maintenance should be done with reference to the following repair parts connection diagram and repair parts list.

Note: Reading the repair parts connection diagram.

- The pattern foil and repair parts are printed in blue.
- The connection points (•W•) for the pattern foil and repair parts are printed in black.

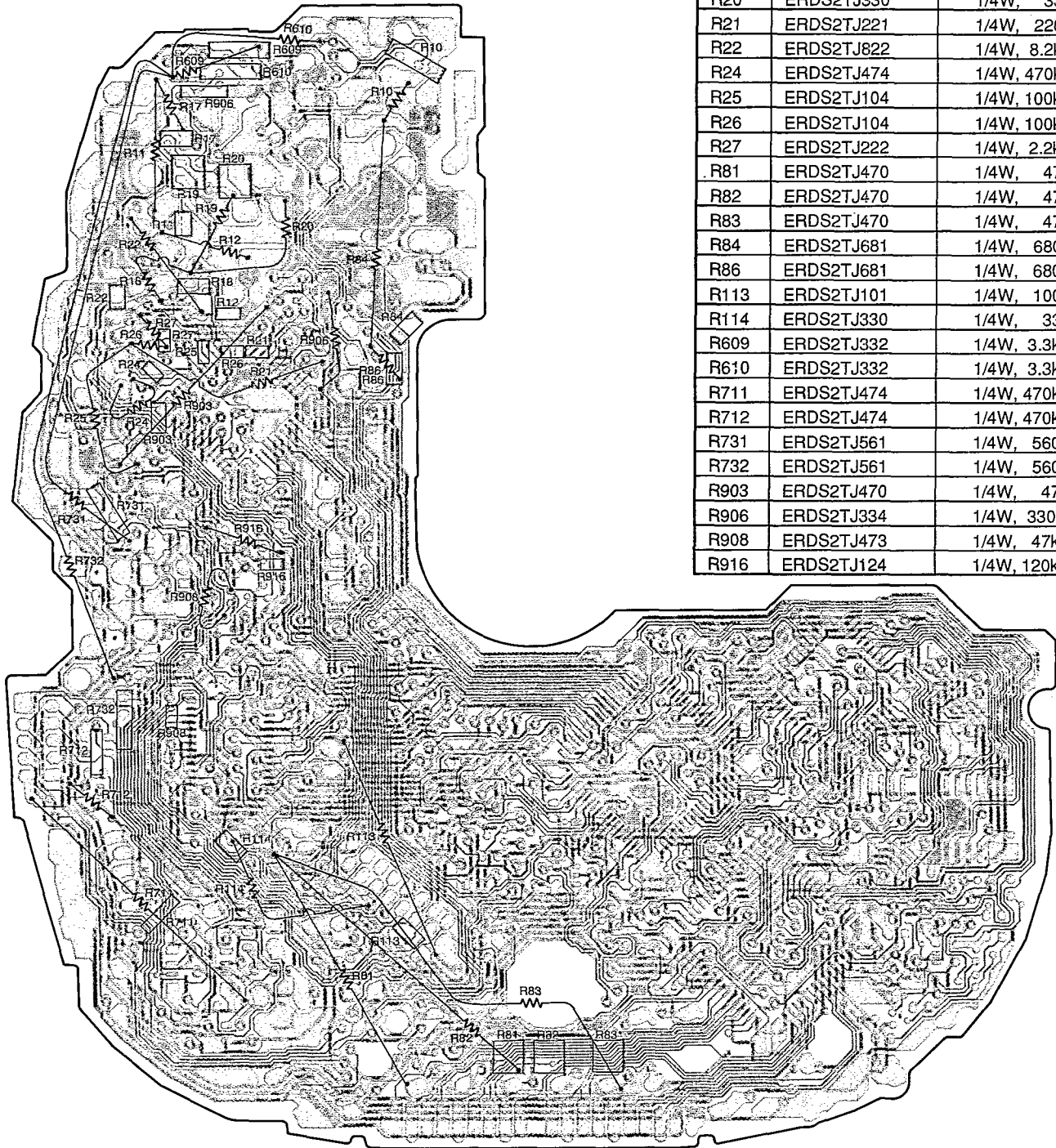

REPLACEMENT PARTS LIST		
Ref. No.	Part No.	Values & Remarks
R10	ERDS2TJ102	1/4W, 1k Ω
R11	ERDS2TJ103	1/4W, 10k Ω
R12	ERDS2TJ472	1/4W, 4.7k Ω
R17	ERDS2TJ152	1/4W, 1.5k Ω
R18	ERDS2TJ101	1/4W, 100 Ω
R19	ERDS2TJ330	1/4W, 33 Ω
R20	ERDS2TJ330	1/4W, 33 Ω
R21	ERDS2TJ221	1/4W, 220 Ω
R22	ERDS2TJ822	1/4W, 8.2k Ω
R24	ERDS2TJ474	1/4W, 470k Ω
R25	ERDS2TJ104	1/4W, 100k Ω
R26	ERDS2TJ104	1/4W, 100k Ω
R27	ERDS2TJ222	1/4W, 2.2k Ω
R81	ERDS2TJ470	1/4W, 47 Ω
R82	ERDS2TJ470	1/4W, 47 Ω
R83	ERDS2TJ470	1/4W, 47 Ω
R84	ERDS2TJ681	1/4W, 680 Ω
R86	ERDS2TJ681	1/4W, 680 Ω
R113	ERDS2TJ101	1/4W, 100 Ω
R114	ERDS2TJ330	1/4W, 33 Ω
R609	ERDS2TJ332	1/4W, 3.3k Ω
R610	ERDS2TJ332	1/4W, 3.3k Ω
R711	ERDS2TJ474	1/4W, 470k Ω
R712	ERDS2TJ474	1/4W, 470k Ω
R731	ERDS2TJ561	1/4W, 560 Ω
R732	ERDS2TJ561	1/4W, 560 Ω
R903	ERDS2TJ470	1/4W, 47 Ω
R906	ERDS2TJ334	1/4W, 330k Ω
R908	ERDS2TJ473	1/4W, 47k Ω
R916	ERDS2TJ124	1/4W, 120k Ω

■ TERMINAL GUIDE

● IC501 (MN662745RPC): Servo processor/Digital signal processor/Digital filter/D/A converter

Pin No.	Mark	I/O Division	Function
1	BCLK	O	Serial bit clock output
2	LRCK	O	L/R discriminating signal output
3	SRDATA	O	Serial data signal output
4	DVDD1	I	Power supply (digital circuit) terminal
5	DVSS1	—	GND (digital circuit) terminal
6	TX	—	Digital audio interface signal (Not used, open)
7	MCLK	I	Command clock signal
8	MDATA	I	Command data signal
9	MLD	I	Command load signal ("L" : LOAD)
10	SENSE	—	Sense signal (OFT, FESL, NACEND, NAJEND, POSAD, SFG) (Not used, open)
11	FLOCK	—	Optical servo condition (focus) ("L" : lead-in) (Not used, open)
12	TLOCK	—	Optical servo condition (tracking) ("L" : lead-in) (Not used, open)
13	BLKCK	O	Sub-code block clock (f=75 Hz)
14	SQCK	I	Sub-code Q register clock
15	SUBQ	O	Sub-code Q data
16	DMUTE	I	Muting input ("H" : MUTE) (Not used, connected to GND)
17	STAT	O	Status signal (CRC, CUE, CLVS, TTSTOP, FCLV, SQCK)
18	RESET	I	Reset signal ("L" : reset)
19	SMCK	O	System clock (f=4.2336 MHz)
20	PMCK	O	Frequency division clock signal ($f = \frac{1}{1.92} \times ck = 88.2 \text{ kHz}$)
21	TRV	O	Traverse servo control

Pin No.	Mark	I/O Division	Function
22	TVD	O	Traverse drive signal
23	PC	O	Turntable motor drive signal ("L" : ON)
24	ECM	O	Turntable motor drive signal (Forced mode)
25	ECS	O	Turntable motor drive signal (Servo error signal)
26	KICK	O	Kick pulse output
27	TRD	O	Tracking drive signal output
28	FOD	O	Focus drive signal output
29	VREF	I	D/A drive output (TVD, ECS, TRD, FOD, FBAL, TBAL) normal voltage input terminal
30	FBAL	O	Focus balance adj. output (Not used, open)
31	TBAL	O	Tracking balance adj. output
32	FE	I	Focus error signal (analog input)
33	TE	I	Tracking error signal (analog input)
34	RFENV	I	RF envelope signal
35	VDET	I	Oscillation det. signal ("H" : det.)
36	OFTR	I	Off track signal ("H" : Off track)
37	TRCRS	I	Track cross signal input
38	RFDET	I	RF detection signal ("L" : detection)
39	BDO	I	Dropout detection signal ("H" : dropout)
40	LDON	O	Laser power control ("H" : ON)
41	TES	—	Tracking error shunt output ("H" : dropout) (Not used, open)
42	PLAY	—	Play signal ("H" : play) (Not used, open)

Pin No.	Mark	I/O Division	Function
43	WVEL	—	Double velocity status signal ("H" : double) (Not used, open)
44	ARF	I	RF signal input
45	IREF	I	Reference current input
46	DRF	—	DSL bias terminal (Not used, connected to GND)
47	DSL F	O	DSL loop filter terminal
48	PLL F	I	PLL loop filter terminal
49	VCO F	I	VCO loop filter terminal (Not used, connected to AVDD2)
50	AVDD2	I	Power supply (analog circuit) terminal (2)
51	AVSS2	—	GND (analog circuit) terminal
52	FS384	—	384 fs (16.9344 MHz) output (Not used, open)
53	PCK	—	PLL extract clock (f=4.3218 MHz) (Not used, open)
54	TROF	—	Tracking servo OFF signal (Not used, open)
55	SUBC	—	Sub-code serial output data (Not used, open)
56	SBCK	—	Sub-code serial input clock (Not used, connected to GND)
57	VSS	—	GND terminal
58	X1	I	Crystal oscillator terminal (f=16.9344 MHz)
59	X2	O	
60	VDD	I	Power supply terminal
61	TRVSTOP	O	Traverse motor stop control terminal
62	CLDCK	—	Sub-code frame clock signal (f CLDCK=7.35 kHz: Normal) (Not used, open)

Pin No.	Mark	I/O Division	Function
63	FCLK	—	Crystal frame clock (Not used, open)
64	IPFLAG	—	Interpolation flag terminal
65	FLAGO	—	Flag terminal
66	CLVS	—	Turntable servo phase synchro signal ("H" : CLV, "L" : Rough servo) (Not used, open)
67	CRC	—	Sub-code CRC check terminal ("H" : OK, "L" : NG) (Not used, open)
68	DEMPHA	—	De-emphasis ON signal ("H" : ON) (Not used, open)
69	FLAG6	—	Flag terminal
70	SEL	—	Not used, connected to GND
71	TEST	I	Test terminal (Normal: "H")
72	AVDD1	I	Power supply (analog circuit) terminal (1)
73	OUTL	O	Lch audio signal
74	AVSS1	—	GND (analog circuit) terminal (1)
75	OUTR	O	Rch audio signal
76	RSEL	I	Polarity direction control terminal of RF signal (Not used, connected to power supply)
77	CSEL	I	Frequency control terminal of crystal oscillator (Not used, connected to GND)
78	ISRDATA	I	Serial data signal input
79	ILRCK	I	L/R discriminating signal input
80	IBCLK	I	Serial bit clock input

● IC11 (AN8788FB): DC-DC converter & motor drive

Pin No.	Mark	I/O Division	Function
1	RESET	O	Reset signal input terminal
2	DED	I	Dead time input terminal
3	OUT	O	DC-DC converter output terminal
4	FB	O	Error amp output terminal
5	IN	I	Error amp input terminal
6	ROUT	O	Remote control interface output terminal
7	SGND	—	GND terminal
8	SPRO	I	Short protection input terminal
9	CT	I	Triangular wave oscillator terminal
10	AREF	O	1/2 AVDD output terminal
11	SV _{CC}	I	Power supply terminal
12	CRIP	I	Capacitor connection terminal for ripple filter
13	AV _{DD}	O	Ripple filter output terminal
14	DRV _{CC}	I	Power supply terminal
15	VREF	I	1/2 VCC input terminal
16	INFO	I	Focus coil driver input terminal
17	INTR	I	Tracking coil driver input terminal
18	LDON	I	Laser ON/ OFF driver control terminal
19	INSP	I	Spindle motor drive input terminal
20	PC	I	Spindle motor driver ON/OFF control terminal
21	INTV	I	Traverse motor driver control terminal
22	TRVSTOP	I	Traverse motor ON/ OFF control terminal

Pin No.	Mark	I/O Division	Function
23	TR-	O	Tracking coil driver output terminal
24	TR+		
25	FO-	O	Focus coil driver output terminal
26	FO+		
27 28	PGND	—	GND terminal
29	SP+	O	Spindle motor driver output terminal
30	SP-		
31	TRV+	O	Traverse motor driver output terminal
32	TRV-		
33	ICNT	I	Rechargeable current setting terminal
34	MRST	O	Muting reset output terminal
35	VSEN	I	Empty det. input terminal
36	EMPTY	O	Empty det. output terminal
37	PV _{CC1}	I	Power supply terminal
38	CLK	I	External synch. clock input terminal
39	START	I	Start oscillator input terminal
40	POWER	I	Power ON/ OFF input terminal
41	PV _{CC2}	I	Power supply terminal
42	I OUT	O	Rechargeable and battery det. terminal
43	DRGND	—	GND terminal
44	RIN	I	Remote control signal input terminal

● IC301 (SC440301FU): System control & LCD drive

Pin No.	Mark	I/O Division	Function
1 } 6	FP6 } FP1	O	LCD segment signal output terminal
7	BP3/FP0		
8 } 10	BP2 } BP0		
11 } 13	VLCD3 } VLCD1	I	Voltage control input terminal
14	V _{DD}	I	Power supply terminal
15	OSC1	I	Main system clock input terminal
16	OSC2	—	Not used, open
17	XOSC2	—	Not used, open
18	XOSC1	—	Not used, connected to GND
19	V _{SS}	—	GND terminal
20	RESET	O	Reset signal output terminal
21	STAT	I	Status signal input (CRC, CUE, CLVS, TT STOP, FCLV, SQOK)
22	BLKCK	I	Sub-code block clock (F=75Hz with normal play)
23	SUBQ	I	Sub-code Q data input terminal
24	SQCK	O	Sub-code Q register clock signal output terminal
25	MEMORY	I	Key switch input terminal (MEMORY)
26	REPEAT	I	Key switch input terminal (REPEAT)
27	STOP	I	Key switch input terminal (STOP)
28	PLAY	I	Key switch input terminal (PLAY/PAUSE)
29	RESUME	I	Key switch input terminal (RESUME)
30	RANDOM	I	Key switch input terminal (RANDOM)
31	HOLD	I	Key switch input terminal (HOLD)
32	EMPTY	I	Empty det. input terminal

Pin No.	Mark	I/O Division	Function
33	OPEN	I	Disc holder open det. terminal ("L" with open)
34	SKIP. R	I	Key switch input terminal (SKIP/SEARCH. R)
35	SKIP. F	I	Key switch input terminal (SKIP/SEARCH. F)
36	WRDRCN/ RSENSE	I/O	Remote control signal terminal
37	BUZ	O	Beep control signal output terminal
38	MODE2	—	Not used, connected to GND
39	POWER	O	Power ON/OFF signal output terminal
40	MUTE	O	Muting signal output terminal ("H" : mute)
41	MLD	O	Command load signal output terminal ("L" : load)
42	MDATA/ BATTERY	O	Command data signal output terminal
43	MCLK/ MODE1	O	Command clock signal output terminal
44	REST	I	Rest det. input terminal
45	RCLK/ STROBE1	O	Remote control clock signal output terminal
46	RDATA/ STROBE2	I/O	Remote control data signal terminal
47	ACDET	I	Power det. input terminal
48	CHARGE/ LIGHT	—	Not used, open
49	LCDREM	—	Not used, open
50	SHOCK. P	I	Key switch input terminal (not used connected to power supply)
51	ZSENSE	I	Sense signal input terminal
52	VUP	O	Reference current control output terminal
53 }	FP18 }	—	Not used, open
54	FP17		
55 } 63	FP16 } FP8	O	LCD segment signal output terminal
64	FP7	—	Not used, open

● IC502 (SM5856A1F) : Shock proof controller

Pin No.	Mark	I/O Division	Function
1	V _{DD} 1	I	Power supply terminal
2	UC1	I	Key input terminal (ANTI-SHOCK MEMORY)
3	XBS	—	Key input terminal (Not used, open)
4	BASS	—	Not used, open
5	ASC	—	Sound quality/sound field control terminal (Not used, open)
6	UC5	O	Sound quality/sound field control terminal
7	NTEST1	—	Test terminal (Not used, open)
8	NTEST2		
9	CLK	I	Clock signal input (f=16.9344MHz)
10	V _{SS}	—	GND terminal
11	YSRDATA	I	Serial data input terminal
12	YLCK	I	L/R clock input terminal
13	YSCK	I	Serial bit clock input terminal
14	ZSCK	O	Serial bit clock output terminal
15	ZLCK	O	L/R clock output terminal
16	ZSRDATA	O	Serial data output terminal
17	YFLAG	I	RAM over-flow flag terminal

Pin No.	Mark	I/O Division	Function
18	YFCLK	I	Crystal frame clock input
19	YBLKCK	I	Sub-cord block clock input terminal
20	RESET	I	Reset input terminal
21	ZSENSE	O	Microcomputer states output terminal
22	RAMSEL	I	Not used, open
23	YDMUTE	I	Mute input terminal
24	YMLD	I	Microcomputer latch clock input terminal
25	YMDATA	I	Microcomputer serial data input terminal
26	YMCLK	I	Microcomputer shift clock input terminal
27	NOE	O	D-RAM output enable terminal
28	NCAS	O	D-RAM column address strobe terminal
29 ┆ 32	D0 ┆ D3	I/O	D-RAM data input/output terminal
33	NWE	O	D-RAM write enable terminal
34	NRAS	O	D-RAM low address strobe terminal
35 ┆ 44	A0 ┆ A9	O	D-RAM address output terminal

● IC503 (LH6456K2) : 1M DRAM

Pin No.	Mark	I/O Division	Function
1	D0	I/O	Data input/output terminal
2	D1	I/O	Data input/output terminal
3	NWE	I	Write enable terminal
4	NRAS	I	Low address strobe terminal
5	A9	I	Address input terminal
6	A0	I	Address input terminal
7 ┆ 9	A1 ┆ A3	I	Address input terminal

Pin No.	Mark	I/O Division	Function
10	VCC	I	Power supply terminal
11 ┆ 15	A4 ┆ A8	I	Address input terminal
16	NOE	I	Output enable terminal
17	NCAS	I	Column address strobe terminal
18	D3	I	Data input terminal
19	D2	I	Data input terminal
20	GND	—	GND terminal

● IC101 (AN8837SBE1): Servo amp.

Pin No.	Mark	I/O Division	Function
1	PDE	I	Tracking signal input terminal (1)
2	PDF	I	Tracking signal input terminal (2)
3	V _{CC}	I	Power supply terminal
4	PDA	I	Focus signal input terminal (1)
5	PDB	I	Focus signal input terminal (2)
6	LPD	I	APC amp input terminal
7	LD	O	APC amp output terminal
8	RF	O	RF summing output terminal
9	RF IN	I	RF signal input terminal
10	CSBRT	O	Capacitor connection terminal for OFTR
11	CEA	O	Capacitor connection terminal for H.P.F. amp
12	BDO	O	Dropout signal output terminal ("H" : Dropout)
13	LDON	I	APC control input terminal
14	GND	—	GND terminal

Pin No.	Mark	I/O Division	Function
15	/RFDET	O	RF det. signal output terminal ("L" : Det.)
16	CROSS	O	Track cross signal output terminal
17	OFTR	O	Off track signal output terminal ("H" : Off track)
18	VDET	O	Vibration det. signal output terminal ("H" : Det.)
19	ENV	O	RF envelope signal output terminal
20	ENV OFF	I	ENV control input terminal
21	TEBPF	I	VDET input terminal
22	TE IN	I	Tracking error amp input terminal
23	TE OUT	O	Tracking error amp output terminal
24	FE OUT	O	Focus error amp output terminal
25	FE IN	I	Focus error amp input terminal
26	VREF	O	Reference voltage output terminal
27	TBAL	I	Tracking balance signal input terminal
28	FBAL	I	Focus balance signal input terminal

CABINET PARTS LOCATION

Note: When changing loading mechanism parts, apply the specified grease to the areas marked "X" as shown in the drawing.

Ref. No.	Part No.
A	RFKXPG671

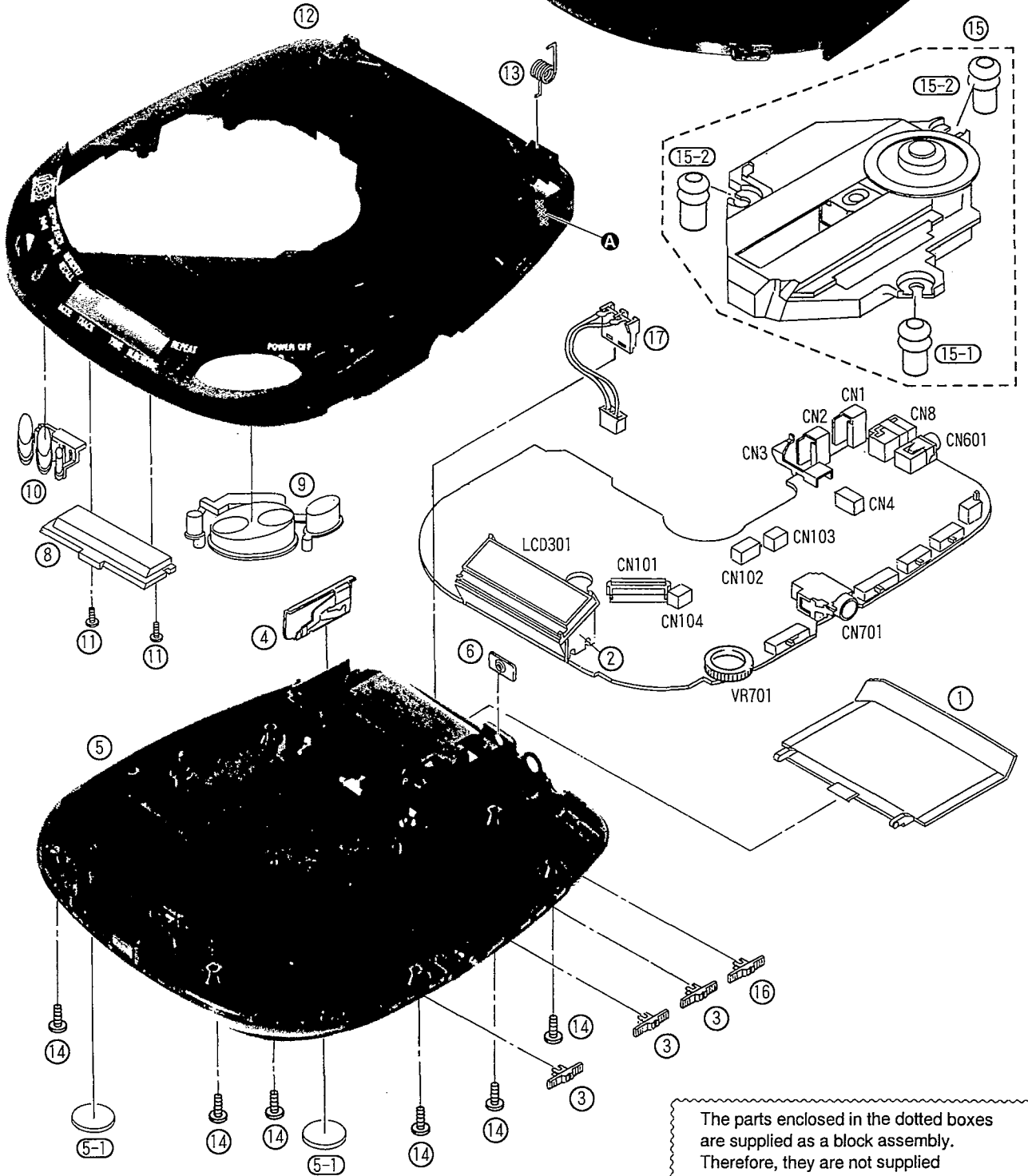
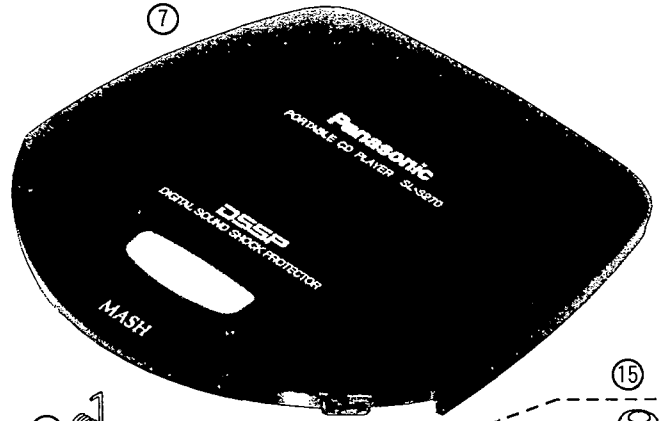

The parts enclosed in the dotted boxes are supplied as a block assembly. Therefore, they are not supplied separately except parts indicated with Ref. No.

REPLACEMENT PARTS LIST

Notes: * Important safety notice:

 Components identified by Δ mark have special characteristics important for safety.

Furthermore, special parts which have purposes of fire-retardant (resistors), high-quality sound (capacitors), low-noise (resistors), etc. are used.

When replacing any of components, be sure to use only manufacturer's specified parts shown in the parts list.

* Warning: This product uses a laser diode. Refer to caution statements on page 2.

Ref. No.	Part No.	Part Name & Description	Remarks	Ref. No.	Part No.	Part Name & Description	Remarks
		CABINET AND CHASSIS		Q603	FMG4T148	TRANSISTOR	
				Q701, 702	2SD1328QRSTX	TRANSISTOR	
				Q903	2SB1218QRSTX	TRANSISTOR	
1	RKK0065-KJ	BATTERY COVER		Q904	UN5114TX	TRANSISTOR	
2	RJF0026	LCD HOLDER		Q905, 906	2SD1819QRSTX	TRANSISTOR	
3	RGV0145-K	XBS/MODE/HOLD KNOB		Q913	2SB1218QRSTX	TRANSISTOR	
4	RJC93020	COMMON BATTERY TERMINAL		Q914	2SD1819QRSTX	TRANSISTOR	
5	RFKJLS270GKK	BOTTOM CABINET ASS'Y		Q915	UN5213TX	TRANSISTOR	
5-1	RKAD063-K	FOOT		Q916	FMG4T148	TRANSISTOR	
6	RMA1008	REAR ORNAMENT		Q917	UN5211TX	TRANSISTOR	
7	RYF0402-K	CD COVER ASS'Y				DIODE (S)	
8	RGPO538-Q	LCD PANEL					
9	RGU1368-H	OPERATION BUTTON (A)		D11	SS14G11	DIODE	
10	RGU1369-H	OPERATION BUTTON (B)		D301	MA151WKT-X	DIODE	
11	RHE5119YA	SCREW		D501	MA8047MTX	DIODE	
12	RFKJLS270-K	INTERMEDIATE CABINET ASS'Y		D502	1SS355TE17	DIODE	
13	RME0210	OPEN SPRING		D701	MA8051MTX	DIODE	
14	XTN17+6GFZ	SCREW		D903, 904	MA151WKT-X	DIODE	
15	RAE0141Z	TRAVERSE DECK	Δ	D905	MA8051MTX	DIODE	
15-1	SHGD157	FLOATING RUBBER(1)				IC PROTECTOR (S)	
15-2	SHGD165	FLOATING RUBBER(2)					
16	RGV0145-H	ANTI-SHOCK KNOB					
17	REX0819	BATTERY CASE TERMINAL (4P)					
		INTEGRATED CIRCUIT (S)		ICP11	UNH000500A	IC PROTECTOR	Δ
						VARIABLE RESISTOR (S)	
IC11	AN8788FB	DC-DC CONV. /MOTOR DRIVE					
IC101	AN8837SBE1	SERVE AMP		VR11	EVNDXAA00B33	POWER SUPPLY VOLTAGE ADJ.	
IC301	SC440301FU	SYSTEM CONT. /LCD DRIVE		VR701	EVUT2FA26C54	VOLUME	
IC501	MN662745RPC	SERVO PROCESSOR				COIL (S)	
IC502	SM5856A1F	SHOCK PROOF CONTROLLER					
IC503	LH6456K2	1M DRAM		L12	RLZ0028T-0	COIL	
IC701	NJU7082AMTE1	HEADPHONES AMP		L502	RLQU331KT-W	COIL	
		TRANSISTOR(S)		L601, 602	RLB0003	COIL	
						OSCILLATOR (S)	
Q11	2SD2074HWRST	TRANSISTOR					
Q12, 13	2SD1450STTA	TRANSISTOR		X501	RSXZ16M9M01T	OSCILLATOR (16.9344MHz)	
Q203	2SB709QRSTX	TRANSISTOR				LCD (S)	
Q501	2SB970RSTX	TRANSISTOR					
Q502	UN5113TX	TRANSISTOR					
Q503, 504	UN5211TX	TRANSISTOR		LCD301	RSL5156-L	LCD	
Q505	UN5215TX	TRANSISTOR				SWITCHES	
Q506	FMW1T98	TRANSISTOR					
Q507	DTA143TUT107	TRANSISTOR					
Q601, 602	2SD1328QRSTX	TRANSISTOR					

Ref. No.	Part No.	Part Name & Description	Remarks	Ref. No.	Part No.	Part Name & Description	Remarks
S201	ESE11SV1	LASER ON/OFF		P3	RPF0111	PROTECTION BAG (UNIT)	
S202	SSHD1-2	REST DETECTOR		P4	RPF0046	PROTECTION BAG (F. B.)	
S301	EVQ21405R	MEMORY/RECALL		P5	RQLA0262	PL LABEL	(GK)
S302	EVQ21405R	REPEAT					
S303	EVQ21405R	SKIP/SEARCH (R)				ACCESSORIES	
S304	EVQ21405R	SKIP/SEARCH (F)					
S305	EVQ21405R	STOP/POWER OFF		A1	RFKLS270GKK	INSTRUCTION MANUAL ASS'Y	
S306	EVQ21405R	PLAY/PAUSE		A2	RFEA401E-3S	AC ADAPTOR	(GK) △
S307	ESD11H230	PLAY MODE SELECTOR		A2	RFEA401E-2S	AC ADAPTOR	(GH) △
S308	ESD11H220	HOLD		A3	RFEV315P-KS	STEREO EARPHONES	
S501	ESD11H220	DSSP		A4	RQCBO169	SERVICENTER LIST	
S701	ESD11H230	TRAIN/S-XBS/OFF		A5* 1	RKB205ZA-0	EAR PADS	
		CONNECTOR (S) AND JACK (S)		A6	RFA0708-K	BATTERY CASE	
				A7	RFEV002PCK1S	REMOTE CONTROL	
CN1	RJC93015-1	BATTERY TERMINAL (+)				<PRINTED CIRCUIT BOARD	
CN2	RJC93015-1	BATTERY TERMINAL (-)				ASS'Y>	
CN3	RJH5102-1	RECHARGEABLE BATT. TERMINAL		PCB1	REP2239K-M	MAIN P. C. B. ASS'Y	(RTL)
CN4	RJT068W04V	CONNECTOR (4P)				<GREASE OR JIG/TOOL>	
CN8	RJJ43K09-C	DC IN JACK				TEST DISC	
CN101	RJU035T016-1	SOCKET (16P)					
CN102	RJT068W04V	CONNECTOR (4P)		SA1	SZZP1054C	PLAYABILITY TEST DISC	
CN103, 104	RJT068W02V	CONNECTOR (2P)		SA2	SZZP1056C	UNEVEN TEST DISC	
CN601	RJJD3S52B-C	OUT JACK				GREASE	
CN701	RJJ36T02-C	HEADPHONES JACK		SA3	RFKXPG671	MOLYCOAT GREASE PG671	
		PACKING MATERIAL					
P1	RPK0783	PACKING CASE					
P2	RPQ0660	SPACER					

*1: This item can be provided only when listed on the replaceable part list.

The marked items (RTL) will be in stock for a limited period. These items will be provided only in a specified period after the discontinuance of production. Valid period will differ depending on types of parts, and accord with the concerned regulations about parts and products in stock.

■ PACKAGING

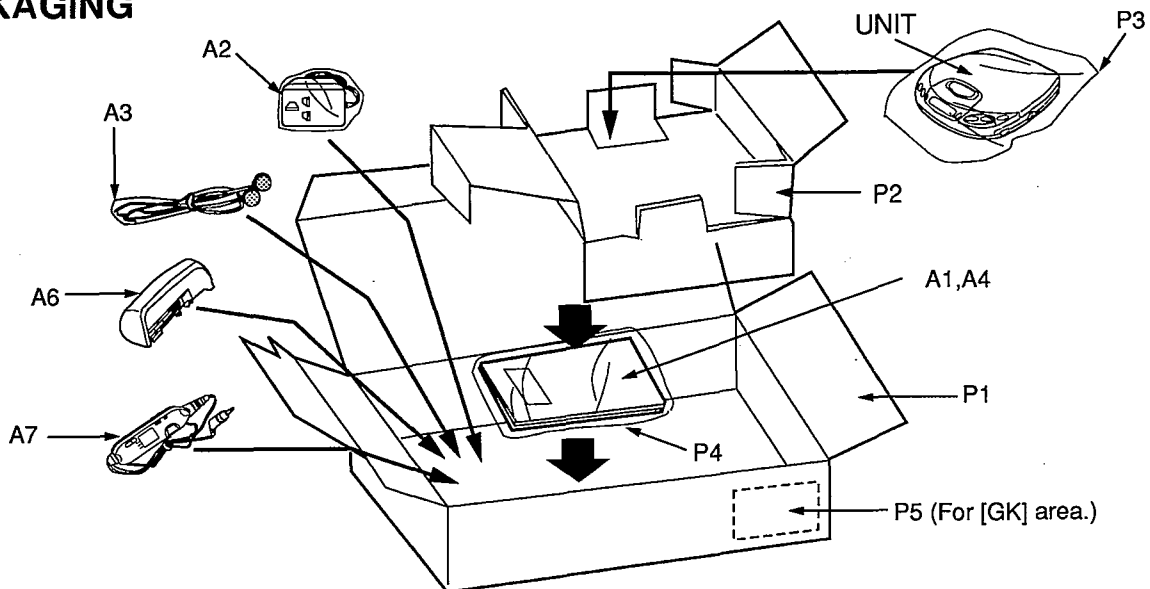

RESISTORS AND CAPACITORS

Notes: * Capacity values are in microfarads (μF) unless specified otherwise, P=Pico-farads (pF) F=Farads (F)
* Resistance values are in ohms, unless specified otherwise, 1K=1,000 (OHM), 1M=1,000k (OHM)

Ref. No.	Part No.	Values & Remarks	Ref. No.	Part No.	Values & Remarks
		RESISTORS	C103	ECUV1E273KBN	25V 0.027U
			C108	ECUV1C473KBN	16V 0.047U
			C109	ECUV1C333KBN	16V 0.033U
R16	ERJ6GEYJ100	1/10W 10	C110	ECUV1E223KBN	25V 0.022U
R28	ERJ6GEYJ823	1/10W 82K	C111	ECUV1E273KBN	25V 0.027U
R29	ERJ6GEYJ821V	1/10W 820	C112	ECUV1H391KBN	50V 390P
R30	ERJ6GEYJ222V	1/10W 2.2K	C113, 114	ECUVNE104ZFN	25V 0.1U
R208	ERJ6GEYJ4R7V	1/10W 4.7	C115	ECUV1E223KBN	25V 0.022U
R409	ERJ6GEYJ824V	1/10W 820K	C120	ECUV1H332KBN	50V 3300P
R501	ERJ6GEYJ683V	1/10W 68K	C121	ECUV1H221KBN	50V 220P
R504	ERJ6GEYJ474V	1/10W 470K	C204	RCE1AKA470IG	10V 47U
R505	ERJ6GEYJ221V	1/10W 220	C205	ECUVNE104ZFN	25V 0.1U
R507	ERJ6GEYJ4R7V	1/10W 4.7	C301, 302	ECUVNE104ZFN	25V 0.1U
R510	ERJ6GEYJ120V	1/10W 12	C404	ECUVNC105ZFN	16V 1U
R512	ERJ6GEYJ471V	1/10W 470	C405	ECUVNE104KBN	25V 0.1U
R513	ERJ6GEYJ222V	1/10W 2.2K	C501, 502	ECUV1H150KCN	50V 15P
R719, 720	ERJ6GEYJ103V	1/10W 10K	C503	ECUV1H561KBN	50V 560P
R725, 726	ERJ6GEYJ180V	1/10W 18	C504	ECUV1C473KBN	16V 0.047U
R727, 728	ERJ6GEYK1R5V	1/10W 1.5	C505	ECUV1E223KBN	25V 0.022U
R901	ERJ6GEYJ821V	1/10W 820	C506	ECUVNC474KBN	16V 0.47U
R921	ERJ6GEYJ103V	1/10W 10K	C507	ECEA0GKA221	4V 220U
R922	ERJ6GEYJ472V	1/10W 4.7K	C508, 509	ECUVNE104ZFN	25V 0.1U
R923	ERJ6GEYJ821V	1/10W 820	C511	ECUVNC474KBN	16V 0.47U
		CHIP JUMPERS	C512	ECUV1E103KBN	25V 0.01U
			C513	RCST1AY475RE	10V 4.7U
			C517	ECUVNE104ZFN	25V 0.1U
RJ11-14	ERJ6GEYOR00V	CHIP JUMPER	C525	ECUVNE104ZFN	25V 0.1U
RJ301	ERJ6GEYOR00V	CHIP JUMPER	C526	RCST0JY475LE	6.3V 4.7U
RJ501	ERJ6GEYOR00V	CHIP JUMPER	C527	ECUVNE104ZFN	25V 0.1U
RJ903	ERJ6GEYOR00V	CHIP JUMPER	C600	ECUVNE104ZFN	25V 0.1U
RJ905	ERJ6GEYOR00V	CHIP JUMPER	C601, 602	ECUV1H102KBN	50V 1000P
		CAPACITORS	C603, 604	ECUV1H272KBN	50V 2700P
			C605, 606	ECEA1CKA100I	16V 10U
			C607, 608	ECUV1H681KBN	50V 680P
C13	RCE0JSL470IX	6.3V 47U	C609	ECUVNE104ZFN	25V 0.1U
C14	ECEA0GKA221	4V 220U	C610	RCE1AKA470IG	10V 47U
C16	ECUVNC224KBN	16V 0.22U	C701, 702	ECUV1E223KBN	25V 0.022U
C17	ECUV1H470KCN	50V 47P	C703, 704	ECUV1E123KBN	25V 0.012U
C18	ECUV1E103KBN	25V 0.01U	C705, 706	ECUV1H152KBN	50V 1500P
C19	ECEA1AKA220I	10V 22U	C709, 710	ECEA0GPK221I	4V 220U
C20	ECEA1EKA4R7I	25V 4.7U	C711, 712	ECEA1CPK100I	16V 10U
C21	ECUV1E223KBN	25V 0.022U	C713	RCE1AKA470IG	10V 47U
C22	ECUVNE104KBN	25V 0.1U	C717	ECUVNE104ZFN	25V 0.1U
C24	ECUV1H391KBN	50V 390P			
C25, 26	ECEA1HKNO10I	50V 1U			
C27-29	RCE1AMT3311V	10V 330U			
C30	ECUVNE104ZFN	25V 0.1U			
C32	ECUV1E103KBN	25V 0.01U			
C101	ECUVNE104KBN	25V 0.1U			

1636