

Service Manual

Portable CD Player

SL-SW404



MASH^{*}
multi-stage noise shaping

※ • MASH is a trademark of NTT.

Colour (A)...Blue Type

Areas

(EB).....Great Britain.
(EG).....Europe.
(GN).....Oceania.

Traverse Deck: RAE0141Z Mechanism Series Specifications

Audio

No. of channels: 2 channels (left and right, stereo)
Output voltage: 0.6 V(50 kohm) diameter 3.5 stereo mini jack
Frequency response: 20~20,000 Hz (+0.5 dB, -1.5 dB)
S/N: more than 94 dB^{*}
Wow and flutter: Below measurable limit
DA converter: 1 bit, MASH^{*}
Headphone output level: max. 9 mW+9 mW/16 ohm (variable)
stereo mini jack diameter 3.5
Digital filter: 8 times over sampling

Signal Format

Correction system: Technics New
Super Decoding Algorithm

Pickup

Type: One beam
Light source: Semiconductor laser
Wavelength: 780 nm
Lens: Glass pressed lens

Playing time; (When used in hold mode, at 25 degree temperature and on flat and stable surface.)

Batteries used Extra anti-shock OFF/ON
Rechargeable batteries About 3 hours/
About 2 hours 30 minutes
Panasonic alkaline dry cell batteries About 10 hours/
About 7 hours 30 minutes
The play time may be less depending on the operating conditions.

Recharging time; About 3 hours

General

Power requirement:

AC; with an included panasonic AC adaptor
RFEA401E-2S (EG)
RFEA404B-1W (EB)
RFEA403A-S (GN)
Batteries; DC 3 V (two "AA" size batteries, not included)
(Panasonic R6P/LR6 or equivalent, not included)
Rechargeable Batteries; DC 2.4 V with an optional Panasonic
Rechargeable Batteries (SH-CDB8D set of 2)
Car Battery; with an optional Panasonic car adaptor (SH-CDC9)

DC IN: DC 4.5 V

Operation temperature range: 0-40 degree

Rechargeable temperature range: 5-40 degree

Power supply: DC 4.5 V

Power consumption:

Power source; Extra anti-shock OFF/ON
Using AC adaptor; 5.5 W/5.7W

Dimensions (W×H×D): 133×31.5×150.5 mm

Weight: 312 g without batteries
357 g with batteries

*These specifications were measured in the extra anti-shock OFF mode.

Note: Design and specifications are subject to change without notice.
Weight and dimensions are approximate.

⚠ WARNING

This service information is designed for experienced repair technicians only and is not designed for use by the general public. It does not contain warnings or cautions to advise non-technical individuals of potential dangers in attempting to service a product. Products powered by electricity should be serviced or repaired only by experienced professional technicians. Any attempt to service or repair the product or products dealt with in this service information by anyone else could result in serious injury or death.

Panasonic[®]

© 1996 Matsushita Electric Industrial Co., Ltd.
All rights reserved. Unauthorized copying and distribution is a violation of law.

Contents

	Page
Precaution of Laser Diode.....	2
Accessories	3
Location of Controls	3
Power Supply Preparations.....	3, 4
Accidental Operation Prevention Function	4
Sequential Play.....	5
Using the Unit with Optional Accessories.....	6
Extra Anti-shock Function.....	6
Cautions	7
Handling Precautions for Traverse Deck.....	8
Operation Checks and Main Component Replacement Procedures	9~12
Checking the Operation Problems on the Traverse Deck (Optical Pickup).....	13

	Page
Automatic Adjustment Results Display Function (Self-check Function).....	14, 15
Mesurements and Adjustments	15, 16
Block Diagram	17~20
Schematic Diagram	21~25
Printed Circuit Board and Wiring Connection Diagram	26
Repairing the Printed Resistor.....	27
Terminal Guide	28~33
Cabinet Parts Location	34
Replacement Parts List.....	35,36
Resistors and Capacitors.....	37
Packaging	37

Precaution of Laser Diode

CAUTION: This product utilizes a laser diode with the unit turned "on", invisible laser radiation is emitted from the pickup lens.

Wave length: 780 nm

Maximum output radiation power from pickup: 100 μ W/VDE

Laser radiation from the pickup lens is safety level, but be sure the followings:

1. Do not disassemble the optical pickup unit, since radiation from exposed laser diode is dangerous.
2. Do not adjust the variable resistor on the pickup unit. It was already adjusted.
3. Do not look at the focus lens using optical instruments.
4. Recommend not to look at pickup lens for a long time.

ACHTUNG: Dieses Produkt enthält eine Laserdiode. Im eingeschalteten Zustand wird unsichtbare Laserstrahlung von der Lasereinheit abgestrahlt.

Wellenlänge: 780 nm

Maximale Strahlungsleistung der Lasereinheit: 100 μ W/VDE

Die Strahlung an der Lasereinheit ist ungefährlich, wenn folgende Punkte beachtet werden:

1. Die Lasereinheit nicht zerlegen, da die Strahlung an der freigelegten Laserdiode gefährlich ist.
2. Den werkseitig justierten Einstellregler der Lasereinheit nicht verstellen.
3. Nicht mit optischen Instrumenten in die Fokussierlines blicken.
4. Nicht über längere Zeit in die Fokussierlines blicken.

ADVARSEL: I dette a apparat anvendes laser.

VARO! Avattaessa ja suoja lukitus ohitettaessa olet aittilina näkymätön lasersäteilyle. Älä katso säteesen.

VARNING! Osynlig laserstråling när denna del är öppnad och spärren är urkopplad. Betrakta ej strålen.

ADVERSEL! Usynlig laserstråling når deksel åpnes og sikkerhedslås brytes. Unngå eksponering for strålen.

(Tuotteen pohjassa)
(Apparatens undersida)
(Produktets underside)

DANGER-Invisible laser radiation when open and interlock defeated. AVOID DIRECT EXPOSURE TO BEAM.

(Bottom of the product)

ADVARSEL: USYNLIG LASERSTRÅLING VED ÅBNING, NÅR SIKKERHEDSAFBRYDERE ER UDE AF FUNKTION. UNDGÅ UDSÆTTELSE FOR STRÅLING.

(Påsat under apparatet)

CAUTION!

THIS PRODUCT UTILIZES A LASER. USE OF CONTROLS OR ADJUSTMENTS OR PERFORMANCE OF PROCEDURES OTHER THAN THOSE SPECIFIED HEREIN MAY RESULT IN HAZARDOUS RADIATION EXPOSURE. DO NOT OPEN COVERS AND DO NOT REPAIR YOURSELF. REFER SERVICING TO QUALIFIED PERSONNEL.

Marking sign is located on bottom of the unit.

Bottom of the unit
Parte inferior del aparato
Apparatens undersida
Komponentens underside
Produktets underside

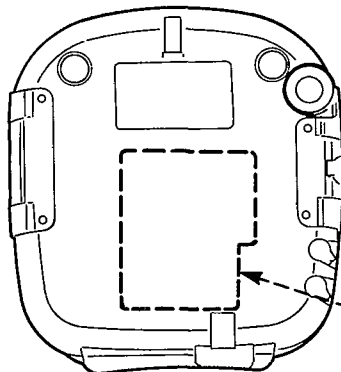

**CLASS 1
LASER PRODUCT**

**LUOKAN 1 LASERLAITE
KLASS 1 LASER APPARAT**

Accessories

- AC adaptor.....1 pc.
(RFEA401E-2S).....For (EG) area only.
(RFEA404B-1W).....For (EB) area only.
(RFEA403A-S).....For (GN) area only.
- Stereo headphones.....1 pc.
(RFEV701P-A1S)
- Rechargeable battery.....2 pcs.
(RP-BP60EYS1).....For (EB),(EG) areas.
(RP-BP60SYS2).....For (GN) area only.
- Battery carrying case.....1 pc.
(RFKNLS370-K)

Location of Controls

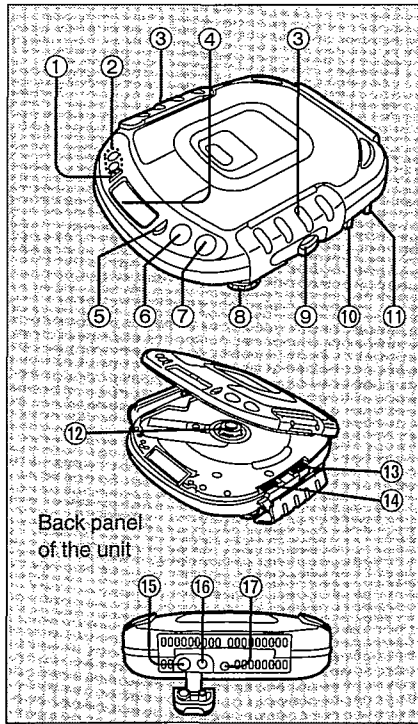

- ① Memory/recall button (MEMORY/RECALL)
- ② Skip/search buttons (◀◀, ▶▶ •SKIP/SEARCH)
- ③ Dual lock
- ④ Display
- ⑤ Repeat button (REPEAT)
- ⑥ Play/pause button (▶ ||)
- ⑦ Stop/power off button (■/POWER OFF)
- ⑧ Headphones volume control (VOLUME)
- ⑨ Headphones jack (⌀) 16Ω ϕ 3.5
- ⑩ Hold switch (HOLD)
- ⑪ Extra anti-shock switch (EXTRA ANTI-SHOCK)
- ⑫ Push button (PUSH)
- ⑬ Play mode selector (MODE)
- ⑭ XBS switch (XBS)
- ⑮ Out jack (OUT)
- ⑯ DC in jack (DC IN 4.5 V ⚡)
- ⑰ Hole for car mounting base

Power Supply Preparations

Refer to the specifications (front cover) for the duration of the play time provided when rechargeable or dry cell batteries are used.

Using rechargeable batteries

Make sure that the rechargeable batteries have been recharged before use.

Recharging procedure

1 Open the disc lid.

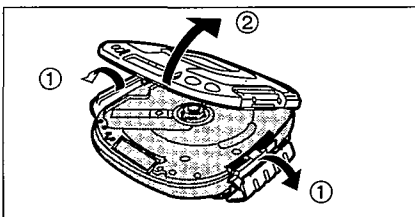

2 Open the battery compartment lid, and place the rechargeable batteries inside the unit.

No batteries other than the special rechargeable batteries can be recharged.

- Accessories (RP-BP60)
- Options (SH-CDB8D)

Note

Be absolutely sure to close the battery compartment lid properly to avoid the damage to the disc.

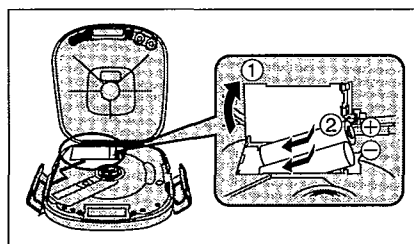

If the battery compartment lid becomes disengaged, insert the protrusions on the lid into the cutouts on both sides of the unit.

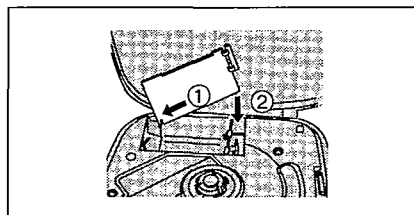

3 Take off the attached rubber cap and connect the AC adaptor.

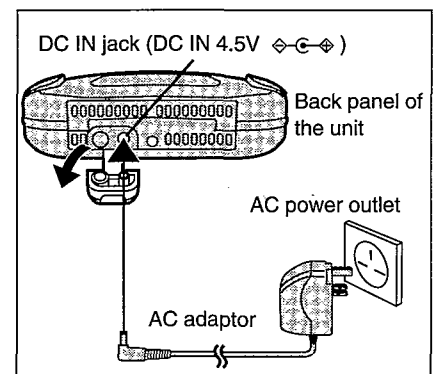

Note

The configuration of the AC adaptor differs according to the area.

- It takes about 3 hours to fully recharge the batteries.

4 Upon completion of the recharging, disconnect the AC adaptor from the DC IN jack and power outlet.

Removing the batteries

Push the batteries upward in the direction of the arrow to remove them.

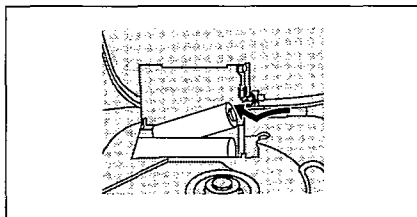

- The batteries can be used for about 10 months (300 times) if they are used every day. They will need to be replaced if the duration of their operation drops drastically.
- You can operate the unit with the AC adaptor while recharging the batteries, but it will lengthen the recharging time.
- Recharging should be performed at 5°C~40°C.
- While recharging, the AC adaptor and rechargeable batteries may get warm. This is normal.

Using the dry cell batteries (not included)

Disconnect the AC adaptor and then install two LR6 (UM-3) type alkaline batteries. The batteries are inserted and removed in the same way as for the rechargeable batteries.

Using the AC adaptor

Connect the AC adaptor supplied. Refer to the section on "Using the rechargeable batteries" for details on the connections.

Note

The unit is in the standby condition when the AC adaptor is connected. The primary circuit is always "live" as long as the AC adaptor is connected to an electrical outlet.

Using the car adaptor (not included)

Be sure to obtain the car adaptor (SH-CDC9), available as an optional accessory. The batteries can be recharged inside the car using the car adaptor.

Battery indicator

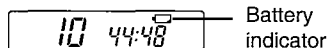

It starts flashing when the batteries have run down. After a short while the power is automatically cut off.

(The amount of time the unit will continue to play after the indicator has started flashing differs slightly, depending on the type of batteries used.)

Type of battery	Action
Rechargeable batteries	Recharge the batteries again.
Dry cell batteries	Replace with new batteries.

(The battery indicator may not flash if rechargeable batteries, other than those designated by Panasonic, are used.)

Accidental Operation Prevention Function

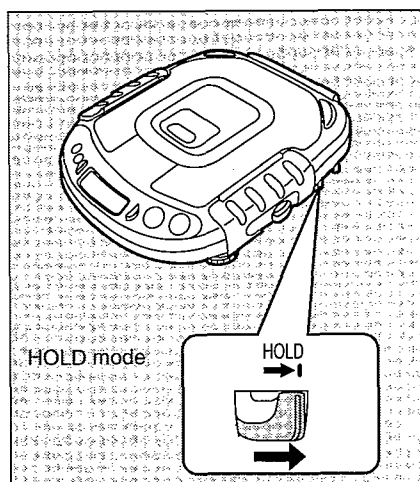

This function prevents the unit from operating even if a control button is pressed in error. (The disc lid can still be opened and closed.)

Use the function to prevent the following situations:

Example 1: While the unit is not in use, the power is inadvertently turned on and the batteries run down.

Example 2: Play is interrupted while the unit is in use.

To use the accidental operation prevention function

Set HOLD to the HOLD position.

"hold" indicator

If the unit is in the hold mode, the "hold" indicator appears when any of the unit's function buttons is pressed.

When the unit is turned off

The "hold" indicator appears only when ►II is pressed.

Before operating the buttons
Be absolutely sure to move HOLD to release the unit from the hold mode.

Be sure to cover the headphones jack, OUT jack and DC IN jack with attached rubber cap when these jacks are not in use.

Side panel of the unit

Back panel of the unit

Sequential Play

- 1 Open the lid, and set MODE to NORMAL.**
- 2 Insert the disc and close the lid.**
 Label must face upward.
 Press the area near the center hole of the disc until it clicks into position.
- 3 Release the hold mode.**
- 4 Take off the attached rubber cap and connect the stereo headphones to the jack.**
 (Plug in firmly)
- 5 Press ► II**
 Play now starts.
 Track number in play

Elapsed playing time of each track
 Play stops automatically when all the tracks have been played.
- 6 Adjust the volume level.**

Operation	Button	Display
Pause: Press during play/press again to resume play	► II	7 0:18
To stop play: Press during play Stop mode	■	Total number of tracks 10 44:48 Total playing time
To turn off the unit: Press during stop mode Off mode	■	
Skip forward/backward (skip function): Press during play Rapid forward/backward (search function): Keep depressed during play	►►: Forward direction ◄◄: Backward direction	—

Removing the disc

After the disc has stopped rotating, open lid, press PUSH to release the disc. (Do not open the lid during play.)

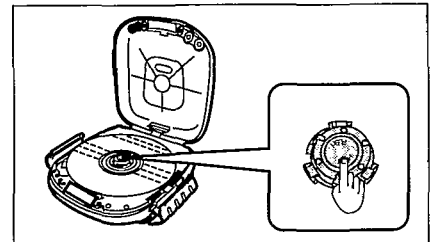

Note

When you open and/or close the lid, be sure to disconnect the stereo headphones plug from the headphones jack to avoid accidental breakage.

Skip and search functions

- During program play the tracks are skipped in the forward or backward direction in the programmed sequence.
- During program play, random play or 1-track repeat play, only the track being played is searched.
- During random play, it is not possible to skip to the track which has already been played.

For your reference:

“no disc” display

This appears for about 30 seconds when a disc has not been inserted or when a disc has not been inserted properly and then ► II is pressed.

“OPEN” display

This appears for about 10 minutes after the lid is opened. (It does not appear when the unit is turned off.)

Note

Do not put anything inside the unit.

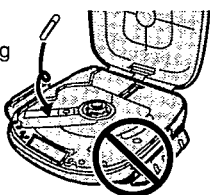

Automatic Shut-OFF function

When the unit is left for about 10 minutes in the stop or pause mode, this function automatically shuts off the power in order to prevent the batteries, etc. from discharging needlessly.

Using the Unit with Optional Accessories

Using the unit with an audio system

Using the stereo connection cable (not included), you can hear CDs on your audio system.

- Connect the cable to the amplifier after turning off its power.
- Do not connect the cable to the PHONO jacks on the amplifier.
- Obtain the optional connecting cable if the amplifier comes with mini-phone jacks.
- Adjust the volume level on the amplifier.

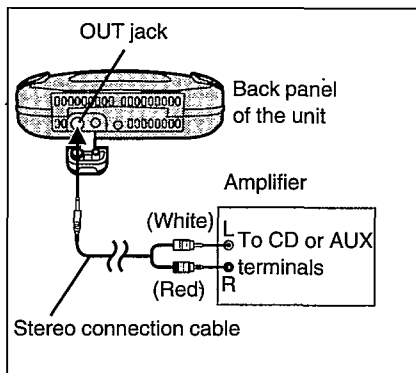

Using the unit with a car audio system

Items to be purchased

For connection to the car audio system:
Car stereo cassette adaptor (SH-CDM9A)

For securing the unit and connecting the power supply:

- Car adaptor (SH-CDC9)
- Car Mount Kit (SH-CDF20)
Car mounting arm, Car mounting base

Note

It may not be possible to use the unit with some types of car audio systems owing to restrictions imposed by the construction of the car stereo cassette adaptor or car Mount kit.

For further details, refer to the instructions of the part concerned.

Extra Anti-shock Function

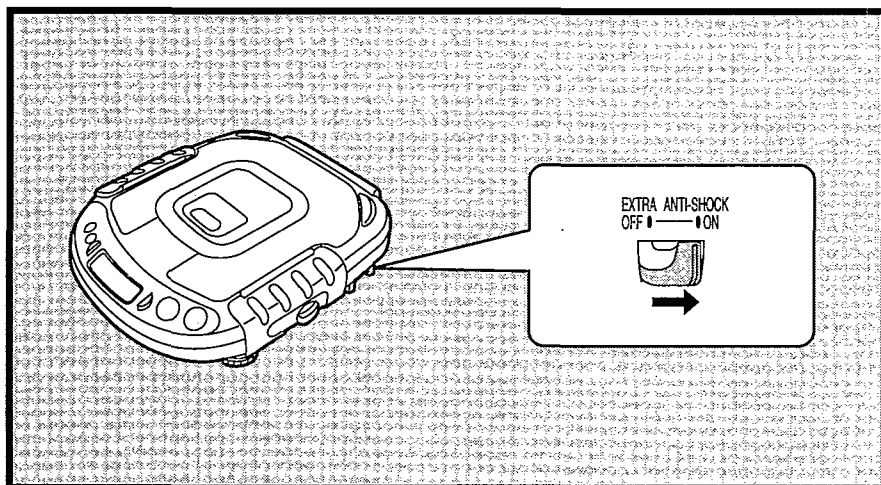

This function minimizes sound interruptions due to vibration when listening to a disc while walking about or in a moving vehicle or train.

Once the extra anti-shock function has been activated, play data of up to 10 seconds can be stored in the memory. Therefore, even if the unit sustains an external impact, the data stored in the memory is sent to minimize sound interruptions during play.

- 1 Set EXTRA ANTI-SHOCK to ON.
- 2 Press ► II.

The function starts to store the play data, and the M.RESERVE indicator on the display shows how much data is stored.

Notes

- The EXTRA ANTI-SHOCK can be set during play but doing so will produce a slight gap in the sound due to a change in the disc speed.
- While the extra anti-shock function is on, the life span of the batteries is shortened and sound made by the rotation of the disc increases somewhat because the disc rotates faster and the play data is stored.

M.RESERVE indicator

M.RESERVE mode	Unit mode	Play mode (play data mode)
	Stable.	Sound is heard (sufficient data has been stored).
	Unit sustains a shock.	Sound is heard (stored data is used).
	Shock subsides.	Sound is heard (data storage commences).
	Unit sustains continuous shocks.	Sound is interrupted (no more data is stored).

Listening to sound with the unit connected to an audio system

The extra anti-shock function incorporates digital signal compression technology. When listening to sound with the unit connected to an audio system at home, it is recommended that the extra anti-shock switch be set to the OFF position.

Cautions

Water Resistant (Splash Proof)

This unit is splash-proof and is not designed to be used under water.

Please note the following points to avoid possible damage to the unit and the included headphones.

- Do not drop them into water and dash much water.
- Since water in the headphones jack, OUT jack and DC IN jack may cause damage, cover it properly with attached rubber cap when these jacks are not in use.
- To prevent water from entering the unit dual locks should be locked to close the disc lid.
- If the unit or the headphones get wet with water or sweat, dry them with a soft cloth.
- Do not open the disc lid near water or sand. Before opening or closing the disc lid, be sure to wipe off water, dust or sand on the unit and operate with a dry hand.
- Make sure of no sand and dust around the disc lid. If there is sand or dust, the disc lid will not close properly and water will get into, which may cause a trouble.
- Do not expose the unit or the headphones to salt water. If the unit and headphones are immersed in salt water, wash them in a little fresh water then dry with soft cloth. Never wash them under running water.
- Do not place the unit and the headphones for a long period of time in high temperature and high humidity area such as bathrooms or damp basements, etc.

AC adaptor

- Handle the AC adaptor carefully. Improper handling is dangerous.
 - Do not touch it with wet hands.
 - Do not place heavy objects on top of it.
 - Do not forcibly bend it.
- Be sure to connect only the AC adaptor provided with the unit.
- Disconnect the AC adaptor from the power outlet if the unit is not going to be used for a long time.

Unit

No altering or remodeling

This can cause malfunctioning.

No dropping or strong impacts

This may damage the unit.

Locations to be avoided

Avoid using the unit in the following locations since they can cause malfunctioning.

1. Bathrooms and other moisture-prone places
2. Warehouses and other dusty places
3. Very hot places near heating appliances, etc.

Do not leave the unit exposed to direct sunlight for long periods of time

This may deform or discolor the cabinet and may also cause malfunctioning.

Rechargeable batteries

- Only the RP-BP60/SH-CDB8D batteries can be recharged.
- If the power delivered by the batteries lasts for a very short time after recharging, it means that the batteries' service life is over. Do not use them any more, please replace the batteries.
- Recharging already charged batteries will shorten their service life.
- When recharging batteries for the first time or when they have not been used for a long period of time, the play time may be shorter than usual. In a case like this, repeatedly recharge and discharge the batteries. This will restore them to their regular charged state.
- Do not allow any metal objects to touch the terminals of rechargeable batteries since this may cause short-circuiting which is dangerous.
- Do not peel off the plastic covering on the rechargeable batteries. Short-circuiting may occur, which is dangerous.

Dry cell batteries/rechargeable batteries

To prevent damage to the batteries and electrolyte leakage, heed the following points into the unit.

- Align the ⊕ and ⊖ polarities properly when inserting the batteries.
- Do not mix different types or makes of batteries or old and new batteries.
- Remove the batteries if you do not plan to use the unit for an extended period of time.
- Do not throw batteries into a fire, and do not short-circuit, disassemble or subject them to excessive heat.
- Do not attempt to recharge dry cell batteries.

Carrying dry cell batteries or rechargeable batteries around

When putting dry cell or rechargeable batteries in a pocket or bag, ensure that no other metal objects, such as a necklace, are placed in the pocket or bag with them. Contact with metal may cause short-circuiting which, in turn, may cause a fire.

Be absolutely sure to carry the rechargeable batteries in the battery carrying case.

When driving a car

For safety reasons, do not operate the unit while driving.

Precautions for Listening with the Headphones or Earphones

- Do not play your headphones or earphones at a high volume. Hearing experts advise against continuous extended play.
- If you experience a ringing in your ears, reduce volume or discontinue use.
- Do not use while operating a motorized vehicle. It may create a traffic hazard and is illegal in many areas.
- You should use extreme caution or temporarily discontinue use in potentially hazardous situations.
- Even if your headphones or earphones is an open-air type designed to let you hear outside sounds, don't turn up the volume so high that you can't hear what's around you.

When purchasing rechargeable batteries

As a safety precaution, the portable CD players made by our company have a construction designed to make it impossible to recharge ordinary batteries.

To use rechargeable batteries, be absolutely sure to purchase the rechargeable Ni-Cd batteries designed especially for this unit.

Special rechargeable Ni-Cd batteries: SH-CDB8D (set of 2)

For details, check with your dealer.

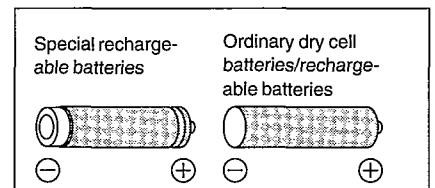

(For United Kingdom)

Notice about the rechargeable battery

The battery is designated recyclable. Please follow your local recycling regulations.

■ Handling Precautions for Traverse Deck

The laser diode in the traverse deck (optical pickup) may break down due to potential difference caused by static electricity of clothes or human body.

So, be careful of electrostatic breakdown during repair of the traverse deck (optical pickup).

● Handling of traverse deck (optical pickup)

1. Do not subject the traverse deck (optical pickup) to static electricity as it is extremely sensitive to electrical shock.
2. The short land between the No. ④ (LD) and No. ⑤ (GND) pins on the flexible board (FFC) is shorted with a solder build-up to prevent damage to the laser diode. To connect to the PC board, be sure to open by removing the solder build-up, and finish the work quickly.
3. Take care not to apply excessive stress to the flexible board (FFC).
4. Do not turn the variable resistor (laser power adjustment). It has already been adjusted.

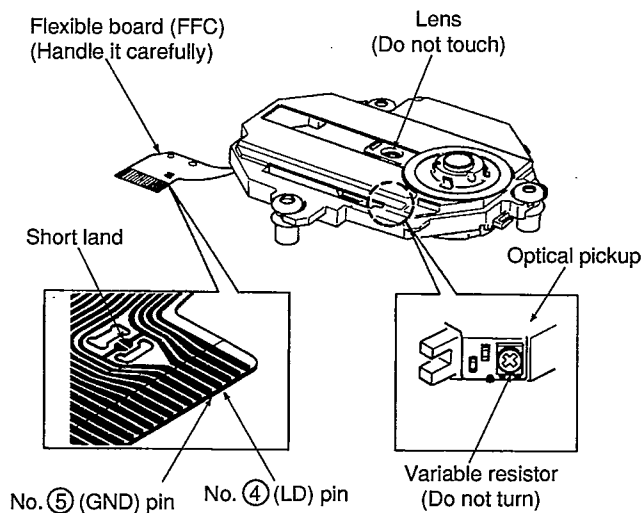

● Grounding for electrostatic breakdown prevention

1. **Human body grounding**
Use the anti-static wrist strap to discharge the static electricity from your body.
2. **Work table grounding**
Put a conductive material (sheet) or steel sheet on the area where the optical pickup is placed, and ground the sheet.

Caution:

The static electricity of your clothes will not be grounded through the wrist strap. So, take care not to let your clothes touch the traverse deck (optical pickup).

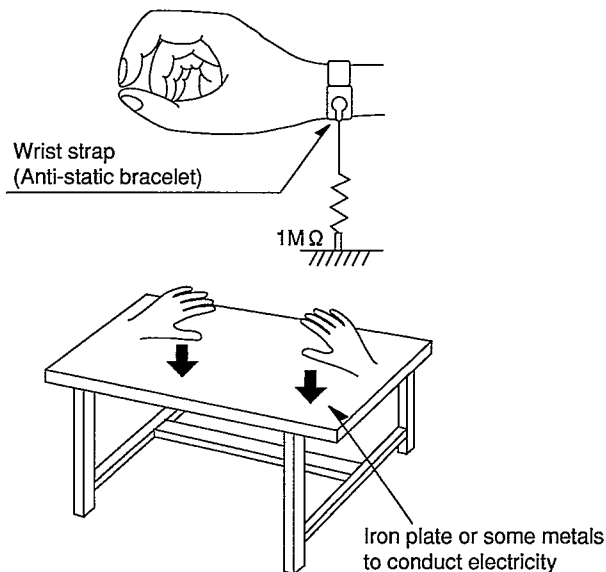

Operation Checks and Main Component Replacement Procedures

Warning: This product uses a laser diode. Refer to caution statements on page 2.

ACHTUNG: • Die Lasereinheit nicht zerlegen.

• Die Lasereinheit darf nur gegen eine vom Hersteller spezifizierte Einheit ausgetauscht werden.

- NOTE**
1. This section describes procedures for checking the operation of the major printed circuit boards and replacing the main components.
 2. For reassembly after operation checks or replacement, reverse the respective procedures. Special reassembly procedures are described only when required.
 3. [] indicates parts No.

1. Checking for the P.C.B.

Step 2

Release the buckle, and then open the CD cover ass'y.

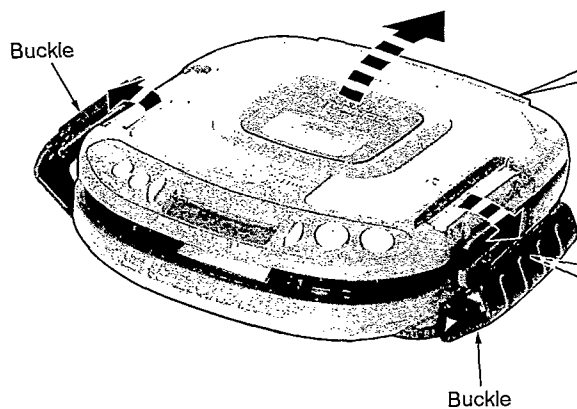

Step 1 Open the water proof cover (A)/(B).

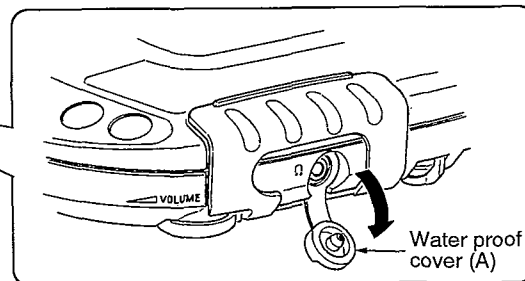
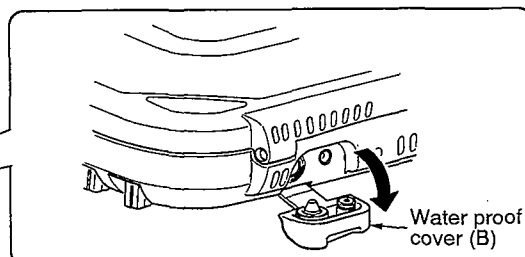

Step 4

Open the battery cover.

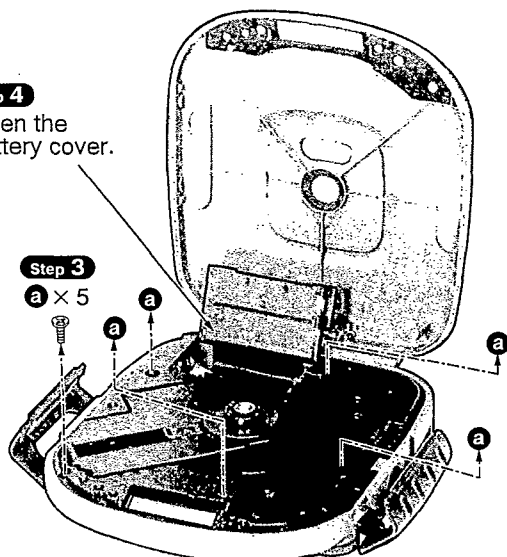

Step 5

Release the intermediate chassis.

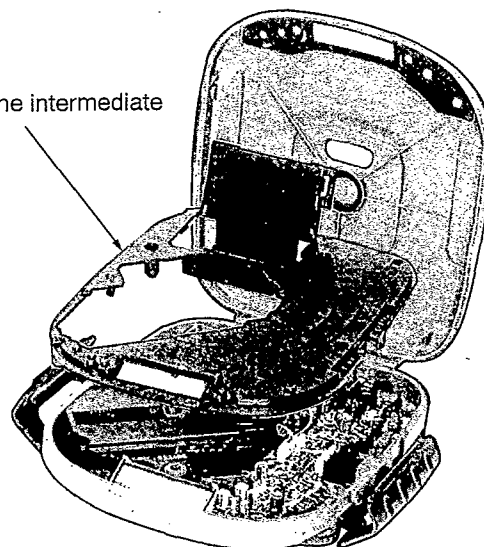

ø1.7 × 6 mm
[XTN17+6GFZ] (Black)

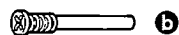

[RHD20039-K] (Black)

Step 7
Remove the CD cover ass'y.

Step 8
Remove the headphones jack ass'y in the direction of arrow.

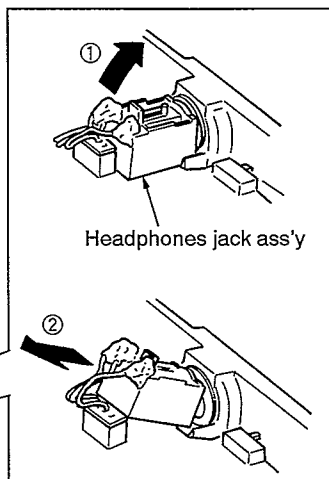
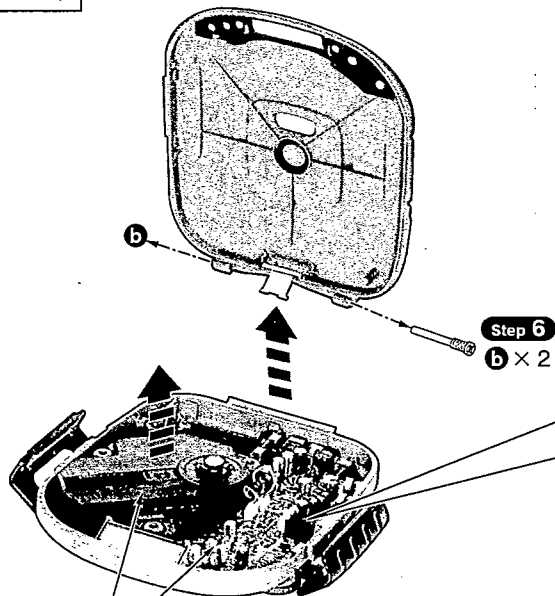

Step 9
Remove the traverse deck and P.C.B..

Traverse deck and P.C.B.

Step 10
Align the bosses of intermediate chassis with the floating rubber of traverse deck ass'y.

• Check the P.C.B. (Solder side) as shown below.

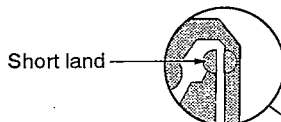
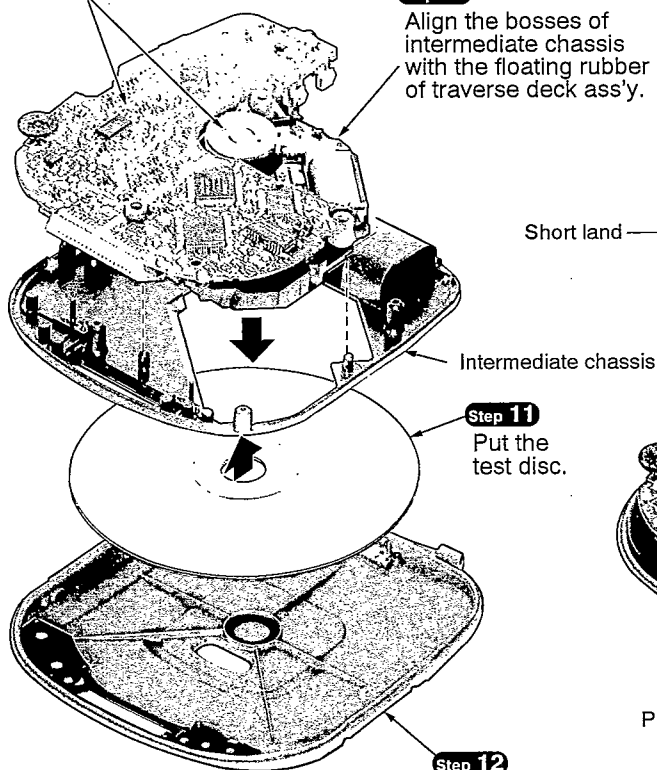

Step 13
Short-circuit the land by soldering.

Step 14
Connect the AC adaptor to the DC IN jack, and then apply DC power.

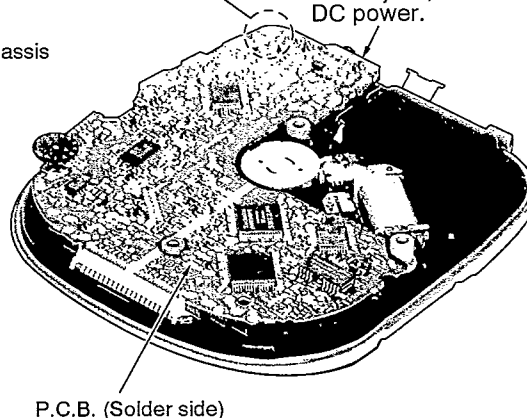

Step 12
Locate the items on the CD cover ass'y.

NOTE
After checking, unsolder the short land to open circuit.

Notice for Installation

1. Installing the P.C.B. to the bottom cabinet ass'y.

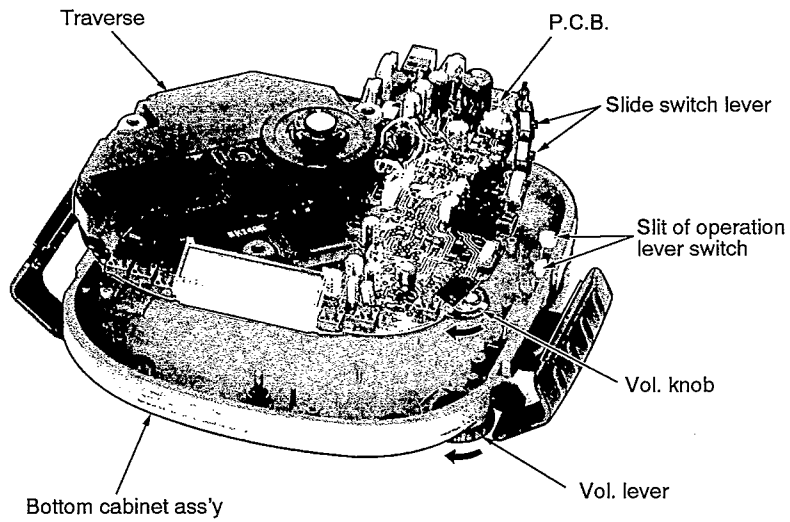

- The Vol. knob and lever should be rotated in the direction of arrow.
- Align the slide switch lever with the slit of lever operation.

2. Installing the intermediate chassis.

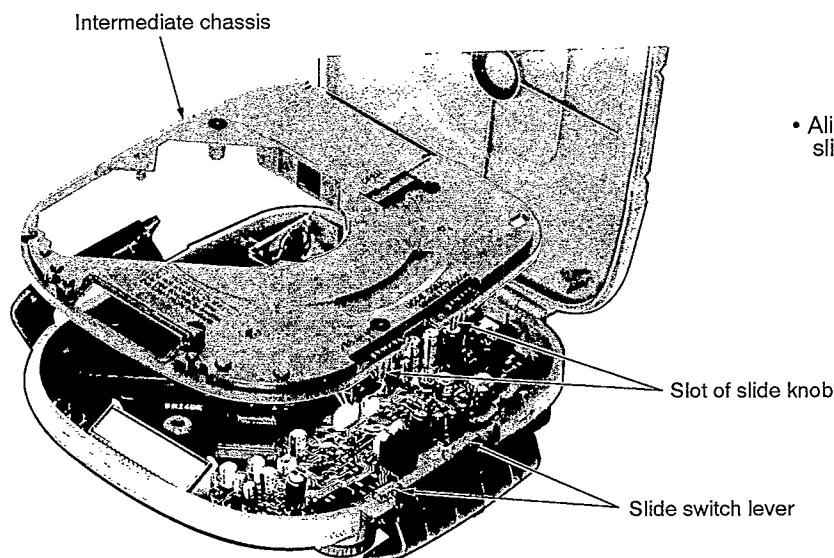

- Align the slot of slide knob with the slide switch lever.

2. Replacement for the traverse deck

• Follow the **Step 1** ~ **Step 5** in item 1.

NOTE

Solder the point between pin 4 (LD) and pin 5 (GND) of FFC board.
(Refer to "Handling Precautions for Traverse Deck" on page 8.)

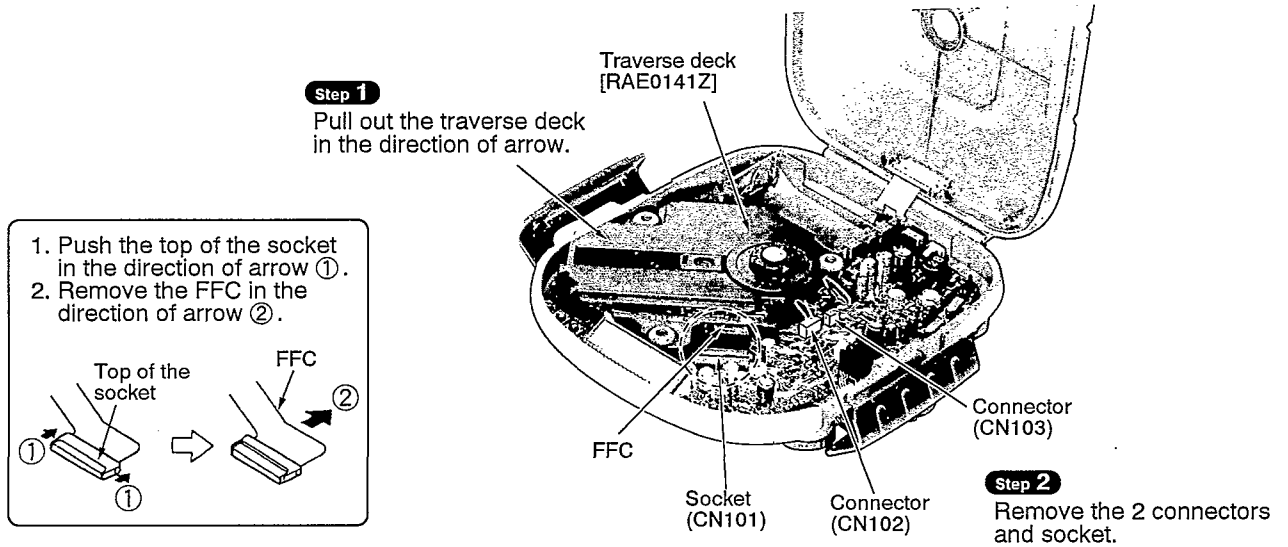

3. Replacement for the CD cover ass'y

• Follow the **Step 1** ~ **Step 7** in item 1.

a
ø1.4 × 4 mm
[RHE5119YA]

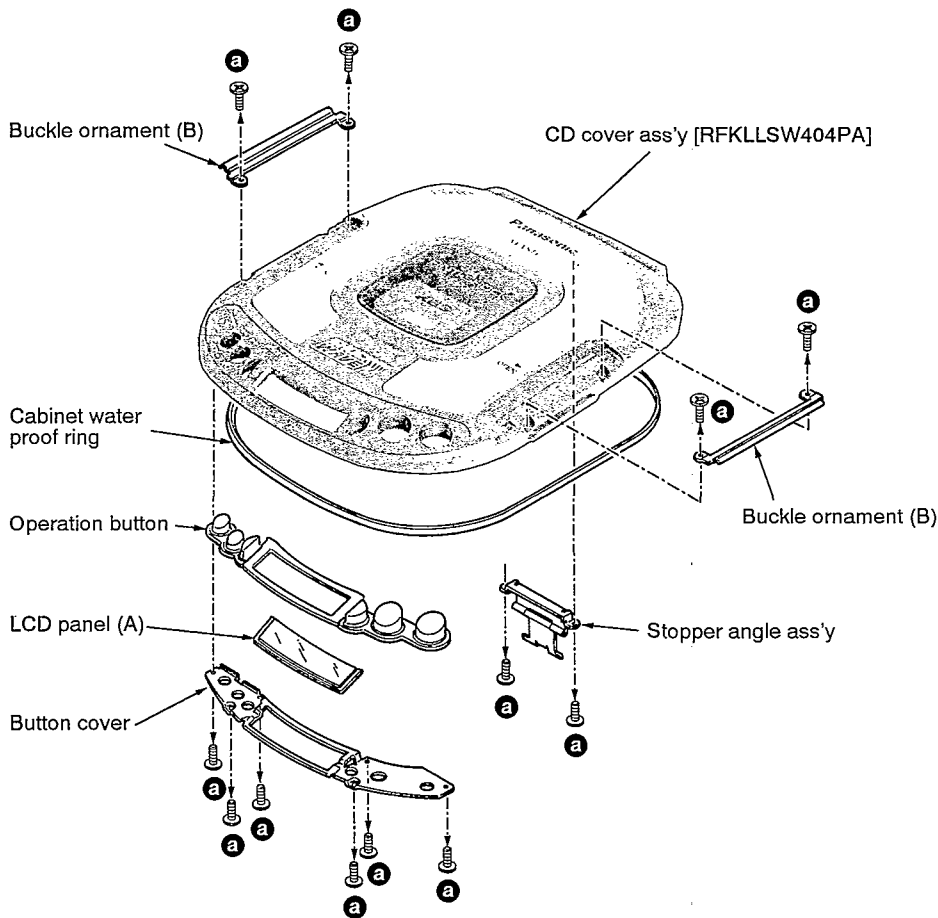

• Notice for installation of CD cover ass'y

The lock angle and open spring should be positioned as shown below.

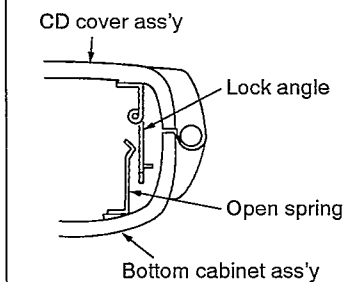

■ Checking the Operation Problems on the Traverse Deck (Optical Pickup)

Make sure to follow the procedures below to check the operation problems of the traverse deck (optical pickup) before replacing it. Replace the traverse deck only after the problem is identified.

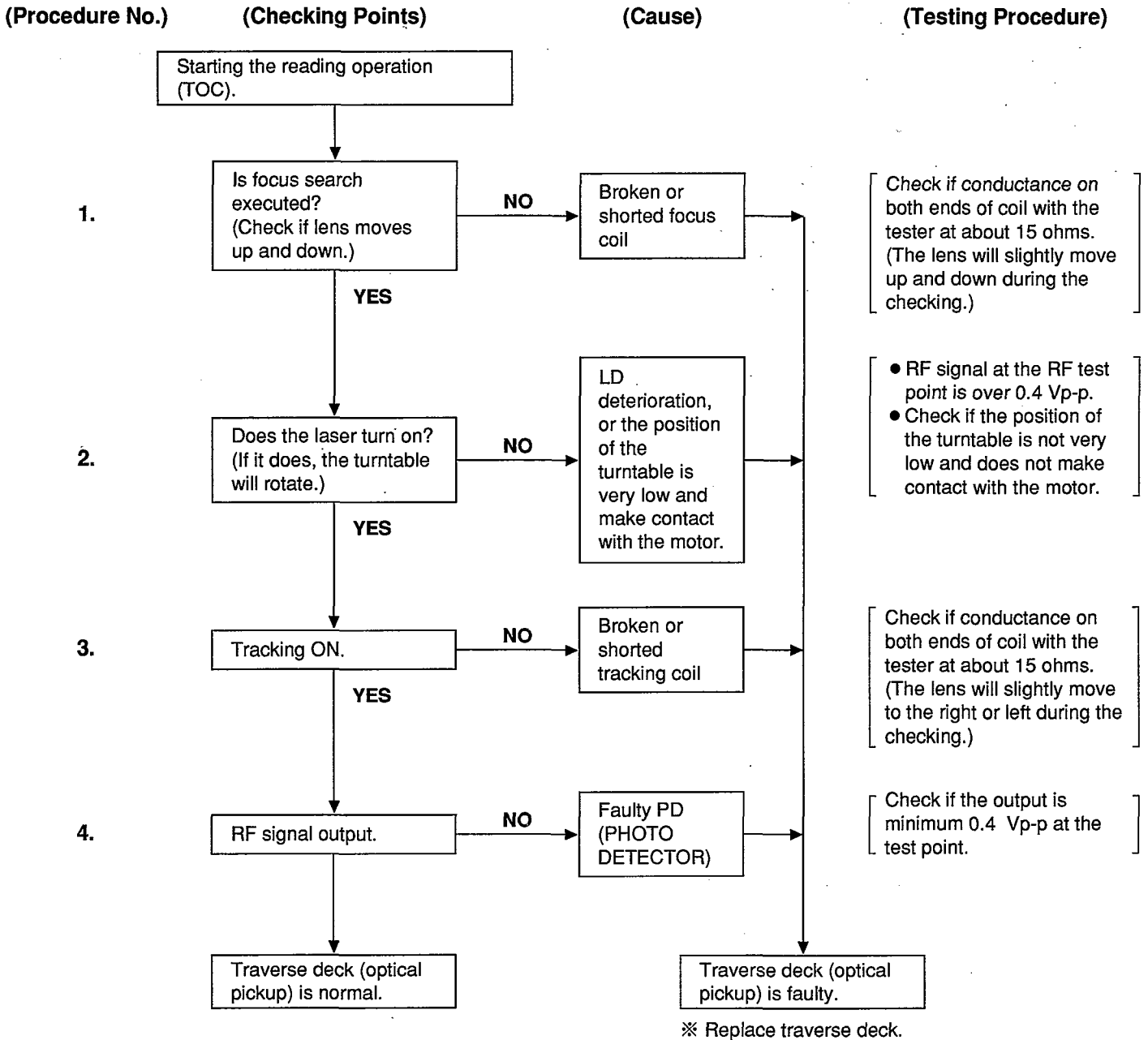

- Check electrical circuit.
- Check for flaws on disc or if it is warped or not centered.

● Check the operations described below on the traverse deck after replacing it.

* Checking Skip Search

1. Play an ordinary musical program disc.
2. Press the skip button to check for normal skip search operation (in both the forward and reverse directions).

* Checking Manual Search

1. Play an ordinary musical program disc.
2. Press the manual search button to check for smooth manual search operations at either low or high speed (in both the forward and reverse directions).

* Checking Playability

1. Play the 0.7 mm black dot and the 0.7 mm wedge on the playability test disc (SZZP1054C) and verify that no sound skip or noise occurs.
2. Play the middle tracks of the uneven test disc (SZZP1056C) and verify that no sound skip or noise occurs.

■ Automatic Adjustment Results Display Function (Self-check Function)

On this unit (SL-SW404), each automatic adjustment result are displayed on the LCD. This function is convenient to check or identify which automatic adjustment circuit is incorrect. The followings are the contents of the automatic adjustment result displays (self-check function).

● How to display automatic adjustment results

1. Load the test disc (SZZP1054C).
2. Press the ◀◀ (SKIP/SEARCH) and ▶▶ (SKIP/SEARCH) Buttons simultaneously and hold them, and additionally press the ▶ / || (PLAY/PAUSE) Button.
3. Press the ■ (STOP/POWER OFF) Button once.
4. An automatic adjustment result is displayed on the LCD.

● Display of automatic adjustment results (self-check function)

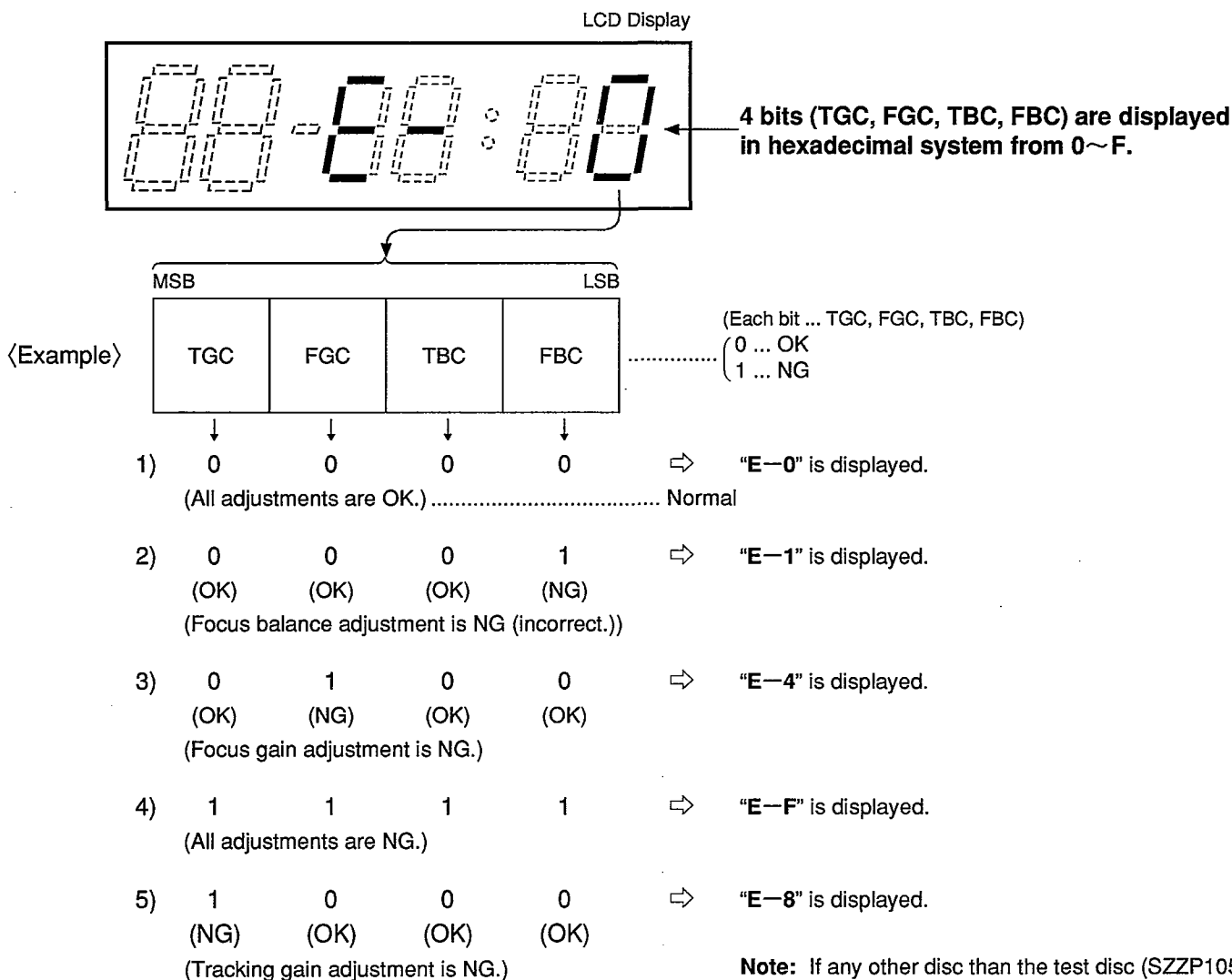

〈Example〉 **Follow the below steps when “E-1” is displayed.**

(Cause: Focus balance (FBC) is set beyond the limit.)

● Check if

- (1) the waveform or voltage of the focus servo circuit is correct, and
- (2) the optical pickup returns to the normal state by exchanging the traverse deck.

Follow the below steps when “E-4” is displayed.

(Cause: Focus gain (FGC) is set beyond the limit.)

● Check if

- (1) the waveform or voltage of the focus servo circuit is correct,
- (2) the focus coil of the optical pickup is correct (around 15 ohms), and
- (3) the optical pickup returns to the normal state by exchanging the traverse deck.

Follow the below steps when “E-F” is displayed.

(Cause : All adjustments (TGC, FGC, TBC, FBC) are set beyond the limit.)

● Check if

- (1) the optical pickup returns to the normal state by exchanging the traverse deck, and
- (2) the waveform or voltage of the servo IC's (IC101, 501) are correct.

Note:

It is not always necessary to exchange the traverse deck when an error message is displayed.
Be sure to check if the circuit is defective or not before exchanging the traverse deck.

Note:

If any other disc than the test disc (SZZP1054C) is used, an error message may be displayed. This is not a malfunction.

■ Measurements and Adjustments

Warning: This product uses a laser diode. Refer to caution statements on page 2.

ACHTUNG: ● Die lasereinheit nicht zerlegen.

- Die lasereinheit darf nur gegen eine vom hersteller spezifizierte einheit ausgetauscht werden.

● Measuring instruments and special tools

● **Test discs**

1. Playability test disc (SZZP1054C)
2. Uneven test disc (SZZP1056C)

● Musical program disc (ordinary)

- DC voltmeter
- Lead wire (for test points)

● Test short land

Short-circuit the lands of the laser ON/OFF switch (S201) by soldering them. It turns “ON” position. (Refer to below **Fig. 1** or printed circuit board and wiring connection diagram for short land location on page 26.)

Note: Remove the solders from the lands after adjustment.

● Adjustment point

- Notes:** 1. Please refer to the printed circuit board and wiring connection diagram for test point locations.
2. Take care to connect CN101, as shown in **Fig. 1**.

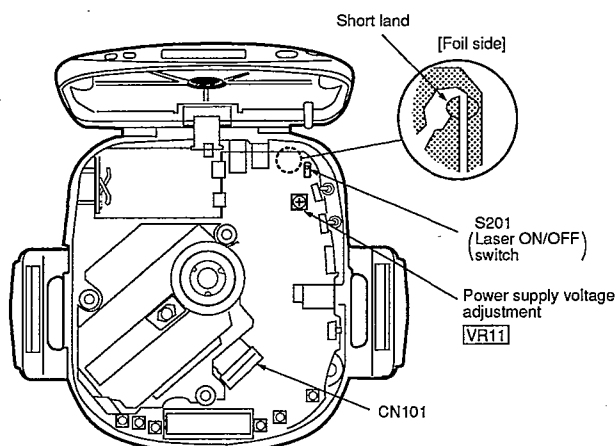

Fig. 1

● Adjustment procedure

(1) POWER SUPPLY VOLTAGE ADJUSTMENT

1. Connect the DC voltmeter to **TP2** (VCC) (+) and **TP3** (GND) on the P.C.B.
2. Connect the AC adaptor cord to the DC (IN) port and move the PLAY switch to the ON position.
(Use a new dry cell battery or a rechargeable battery that is full charged.)
3. Insert the test disc, and switch the player power ON.
4. Adjust **VR11** on the P.C.B. at 3.32 ± 0.02 V, as shown in **Fig. 1**.

(2) CHECK OF PLAY OPERATION

*Checking Skip Search

1. Play an ordinary musical program disc.
2. Press the skip button to check for normal skip search operation (in both the forward and backward directions).

*Checking Manual Search

1. Play an ordinary musical program disc.
2. Press the manual search button to check for smooth manual search operations at either low or high speed (in both the forward and backward directions).

*Checking Playability

1. Play the 0.7 mm black dot and the 0.7 mm wedge on the playability test disc (SZZP1054C) and verify that no sound skip or noise occurs.
2. Play the middle tracks of the uneven test disc (SZZP1056C) and verify that no sound skip or noise occurs.

● Automatic adjustment

On our conventional type portable CD player, there were mounted 6 semi-fixed controls for each adjustment. Since the SL-SW404 servo circuit is equipped with an automatic adjusting circuit, these controls are removed from SL-SW404.

On conventional portable CD player
Use for Old Servo IC (AN8373SE2, AN8374SE2)

1. Tracking Offset Adjustment VR (TOC)
2. Focus Offset Adjustment VR (FOC)
3. Tracking Gain Adjustment VR (TGC)
4. Focus Gain Adjustment VR (FGC)
5. Tracking Balance Adjustment VR (TBC)
6. Focus Balance Adjustment VR (FBC)

On SL-SW404
Use for New Servo IC (AN8837SBE1, MN662745RPC)

- ➔ Non Adjustment
- ➔ Automatic Adjusting Circuit

Total 6 Adjustment VRs

➔ No Adjustment VR

Although all discs are manufactured according to the same specifications, their characteristics are not always precisely the same because they are produced by different manufacturers in various lots, or have different warp etc. SL-SW404 automatically controls the servo circuit to obtain optimum performance according to any disc's characteristics. Therefore, no malfunction occurs because of mis-adjustment.

● Signal line ➡ : Audio signal

Block Diagram

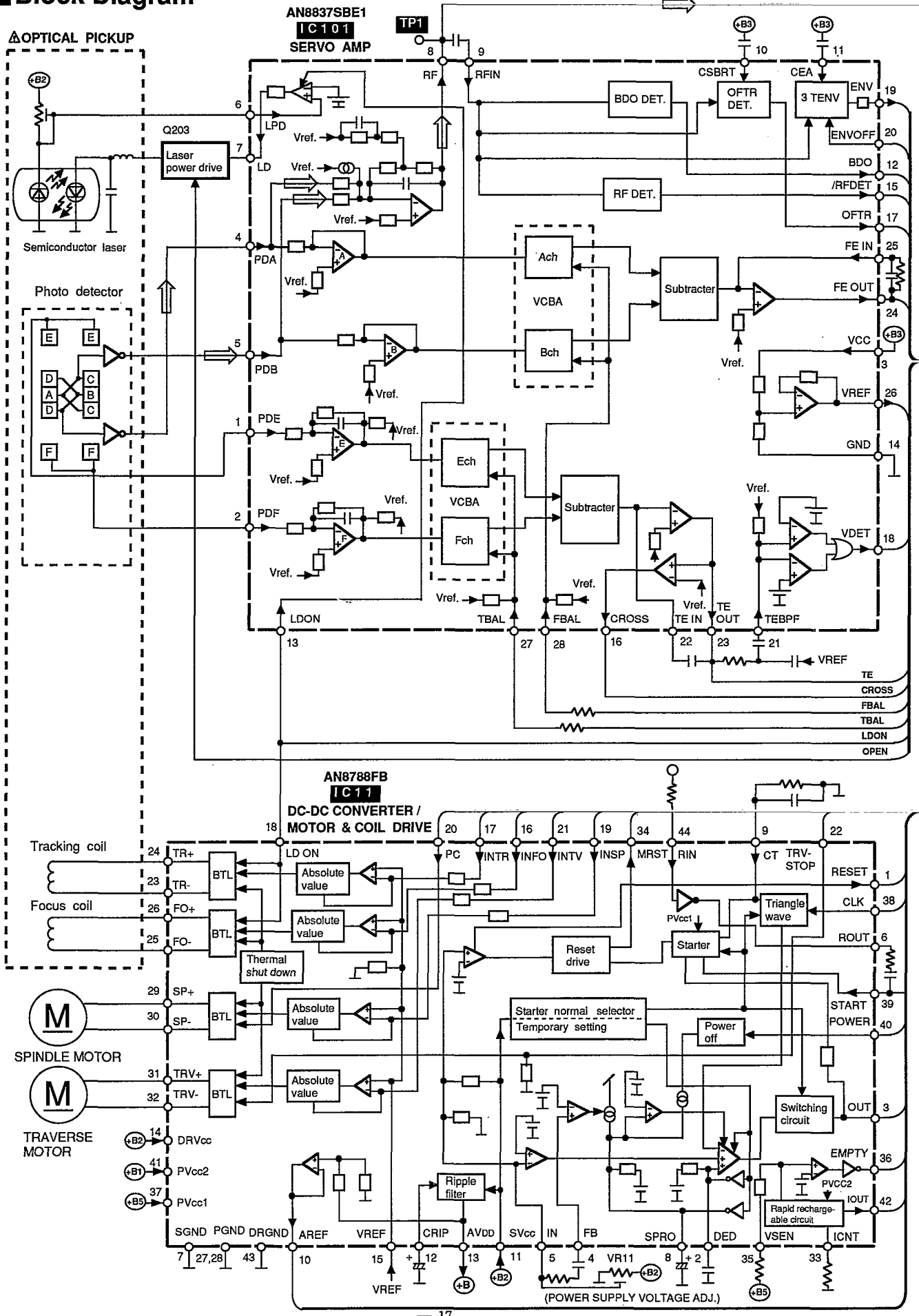

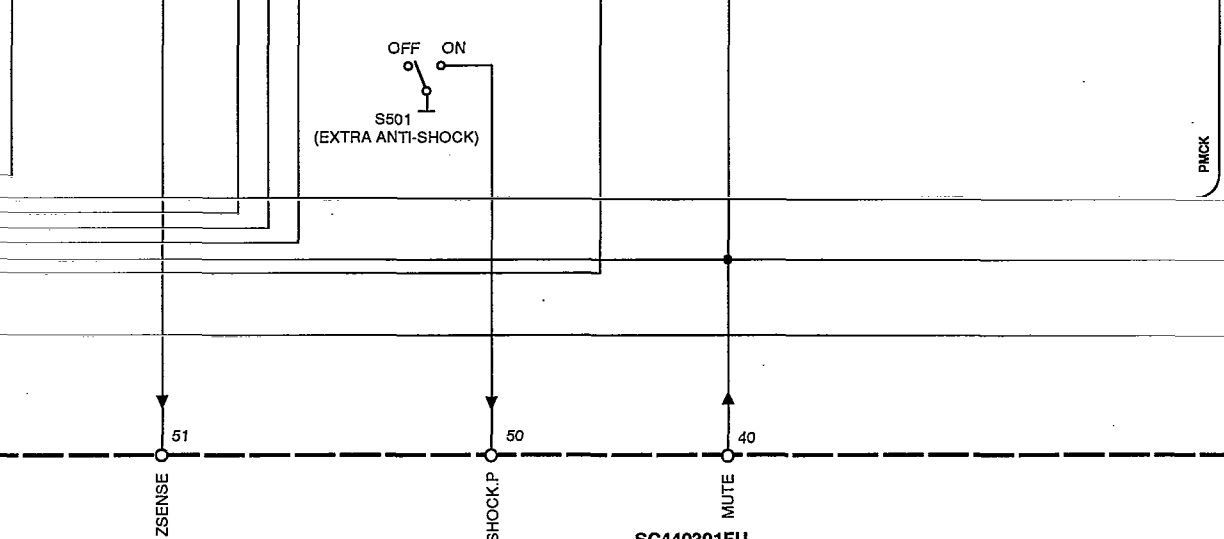
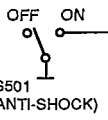
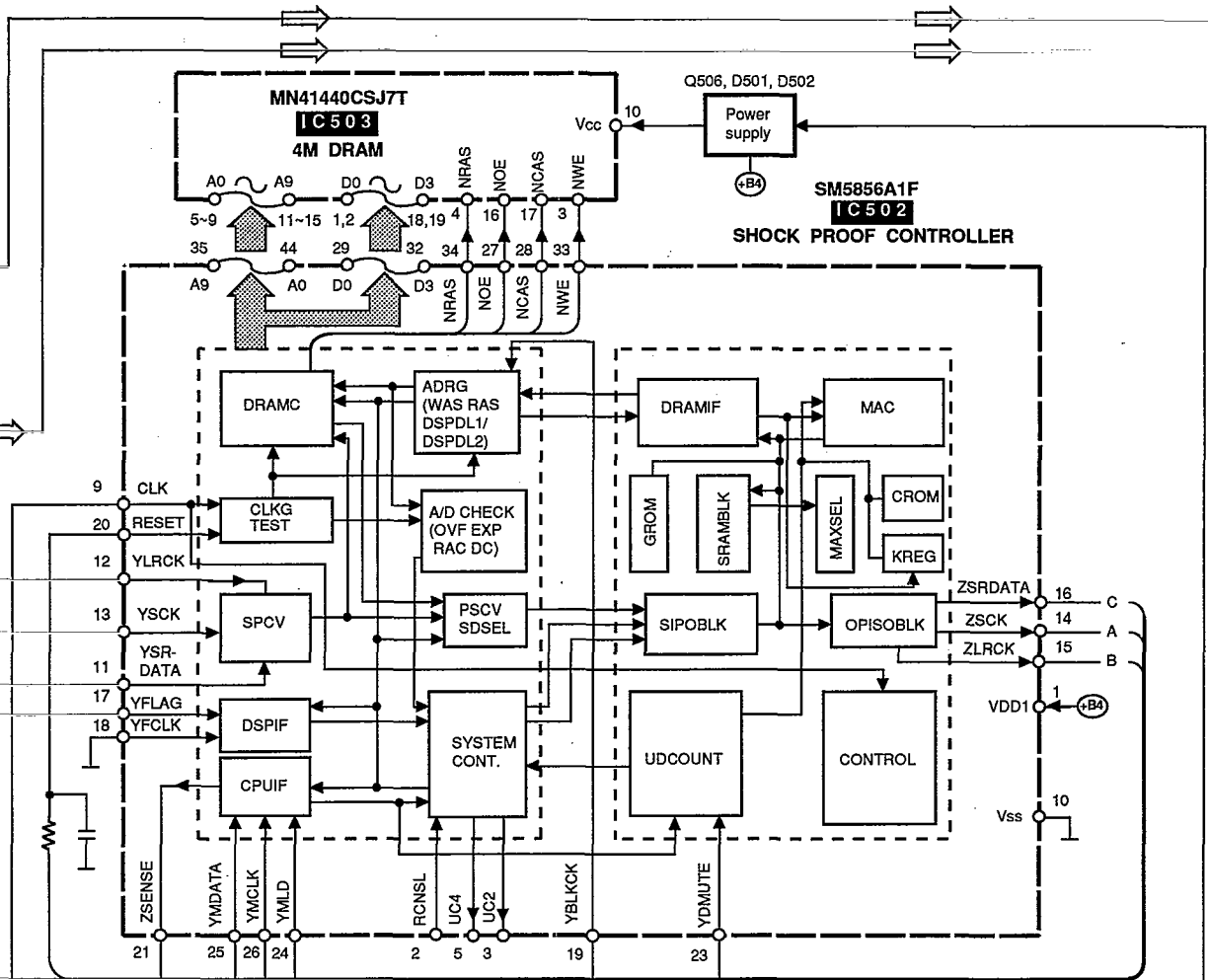

● Signal line ⇨ : Audio signal

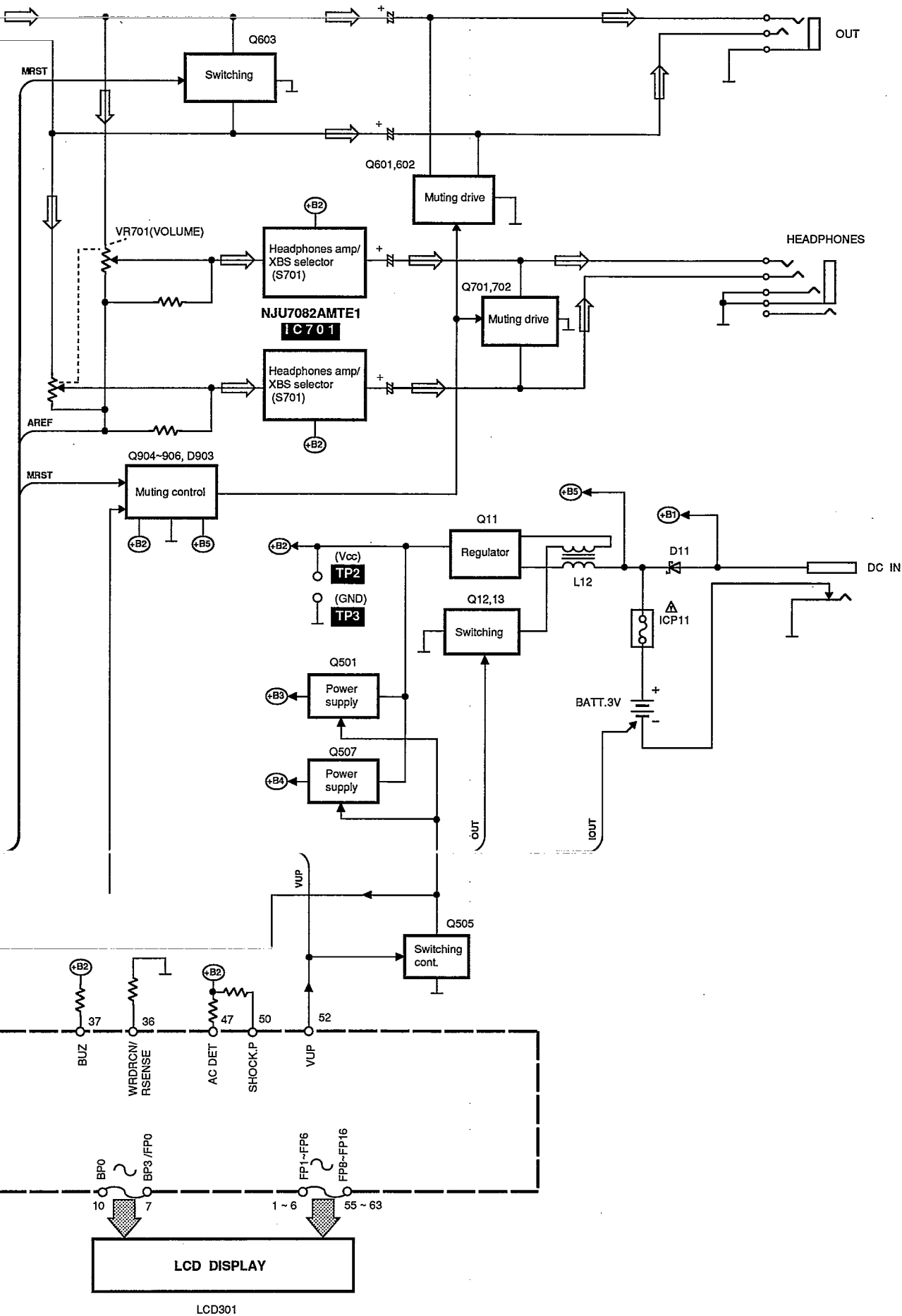

Schematic Diagram (See parts list on pages 35~37.)

(This schematic diagram may be modified at any time with the development of new technology.)

Notes:

- **S201**: Laser ON/OFF switch in "OFF" position.
(It turns "ON" with disc holder closed.)
- **S202**: Rest detector in "OFF" position.
(It turns "ON" when optical pickup comes to innermost periphery.)
- **S301**: Memory/recall (MEMORY/RECALL) switch.
- **S302**: Repeat (REPEAT) switch.
- **S303, 304**: Skip/search (◀◀-SKIP/--SEARCH▶▶) switches.
(S303: ▶▶, S304 : ◀◀)
- **S305**: Stop/power off (■ POWER OFF) switch.
- **S306**: Play/pause (▶ ||) switch.
- **S307**: Play mode selector (MODE) in "RANDOM" position.
(RANDOM↔NORMAL↔RESUME)
- **S308**: Hold (HOLD) switch in "ON" position.
- **S501**: Extra anti-shock switch in "ON" position.
- **S701**: XBS selector in "ON" position.
- The voltage value and waveforms are the reference voltage of this measured by DC electronic voltmeter (high impedance) and oscilloscope on the basis of GND terminal (DC IN Jack). Accordingly, there may arise some errors in the voltage values and waveforms depending upon the internal impedance of the tester or measuring unit.

*The parenthesized is the voltage for test disc (1 kHz, L+R, 0 dB) in play mode, and the other, for no disc in stop mode.
* AC adaptor is used for power supply.

●  : Positive voltage lines.

●  : Audio signal lines.

● Important safety notice:

Components identified by  mark have special characteristics important for safety. Furthermore, special parts which have purposes of fire-retardant (resistors), high-quality sound (capacitors), low-noise (resistors), etc. are used. When replacing any of components, be sure to use only manufacture's specified parts shown in the parts list.

● * marks indicate printed resistor.

Caution!

IC and LSI are sensitive to static electricity.

Secondary trouble can be prevented by taking care during repair.

● Cover the parts boxes made of plastics with aluminum foil.

● Ground the soldering iron.

● Put a conductive mat on the work table.

● Do not touch the pins of IC or LSI with fingers directly.

Terminal guide of IC's, transistors and diodes

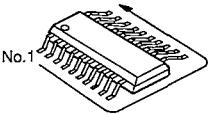
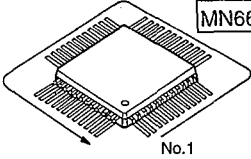
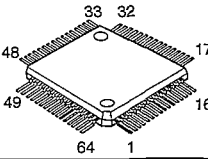
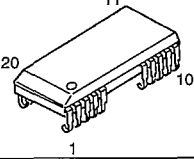
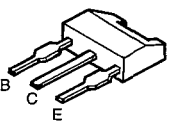
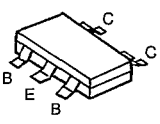
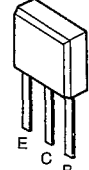
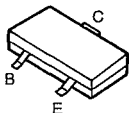
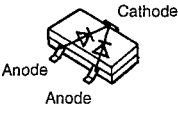
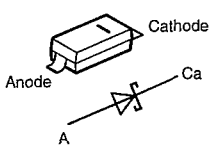
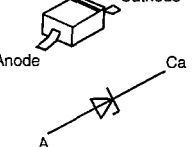
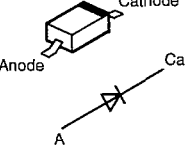
<table border="1"> <tr> <td>NJU7082AMTE1</td> <td>8PIN</td> </tr> <tr> <td>AN8837SBE1</td> <td>28PIN</td> </tr> </table>  <p>No.1</p>	NJU7082AMTE1	8PIN	AN8837SBE1	28PIN	<table border="1"> <tr> <td>AN8788FB</td> <td>44PIN</td> </tr> <tr> <td>SM5856A1F</td> <td>44PIN</td> </tr> <tr> <td>MN662745RPC</td> <td>80PIN</td> </tr> </table>  <p>No.1</p>	AN8788FB	44PIN	SM5856A1F	44PIN	MN662745RPC	80PIN	<p>SC440301FU</p> 	<p>MN41440CSJ7T</p> 
NJU7082AMTE1	8PIN												
AN8837SBE1	28PIN												
AN8788FB	44PIN												
SM5856A1F	44PIN												
MN662745RPC	80PIN												
<p>2SD2074HWRST</p> 	<p>FMG4T148 FMW1T98</p> 	<p>2SD1450STTA</p> 	<p>2SB709QRSTX</p> 	<p>2SB970RSTX 2SD1328RSTTX 2SD1819QRSTX DTA114YUA106 DTA143TUT107 UN5113TX UN5211TX UN5215TX</p> <p>MA151WKTX</p> 									
<p>SS14G11</p> 	<p>MA8047MTX</p> 	<p>1SS355TE17</p> 											

• → : Audio signal lines.
(P.C.Board: on page 26)

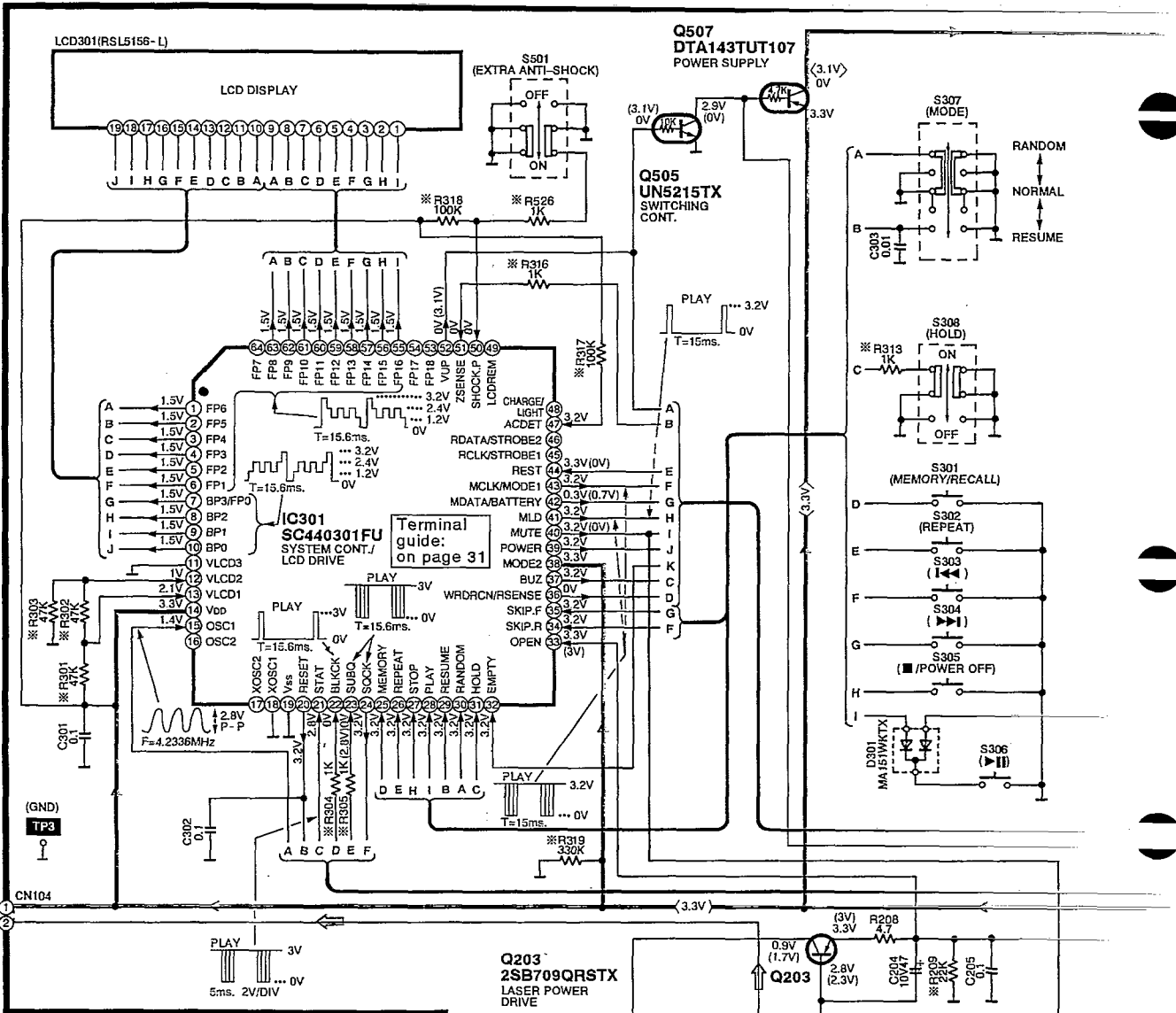

△ OPTICAL PICKUP

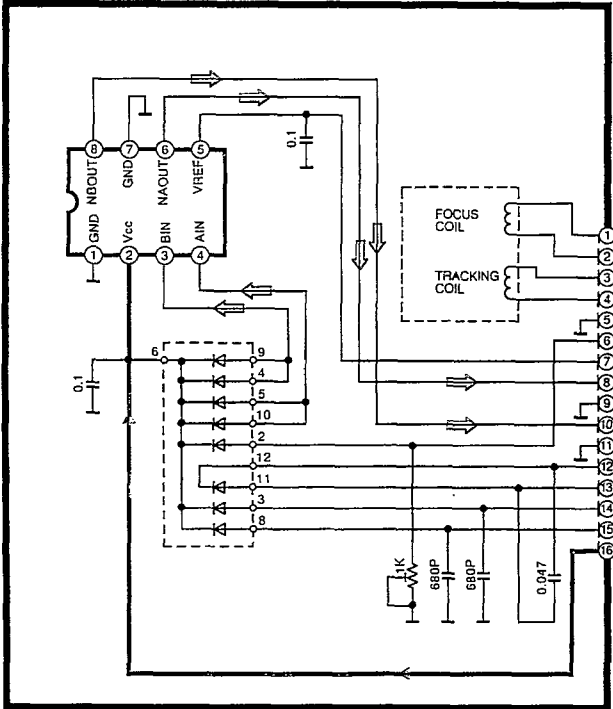

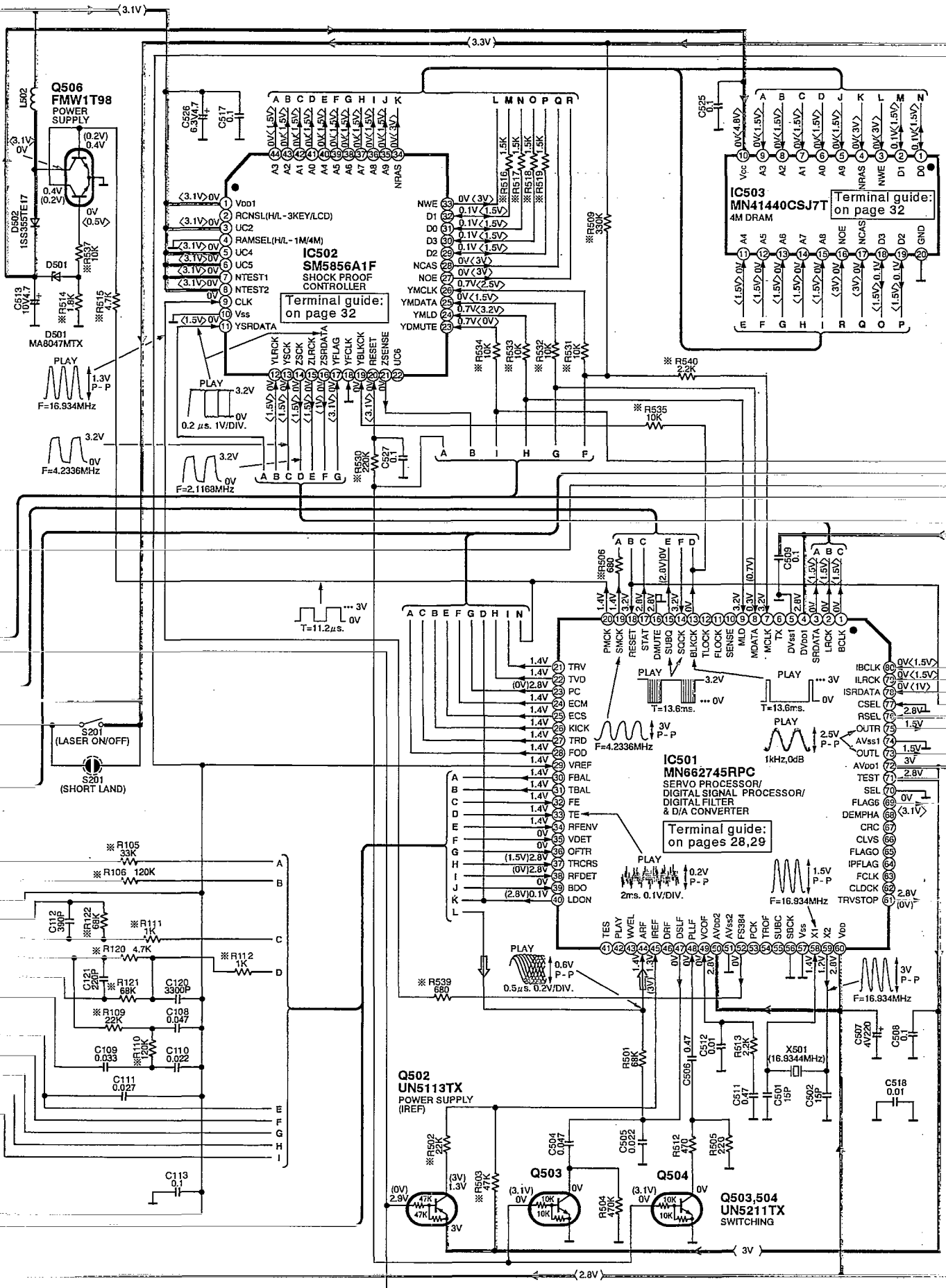

➔ : Audio signal lines.

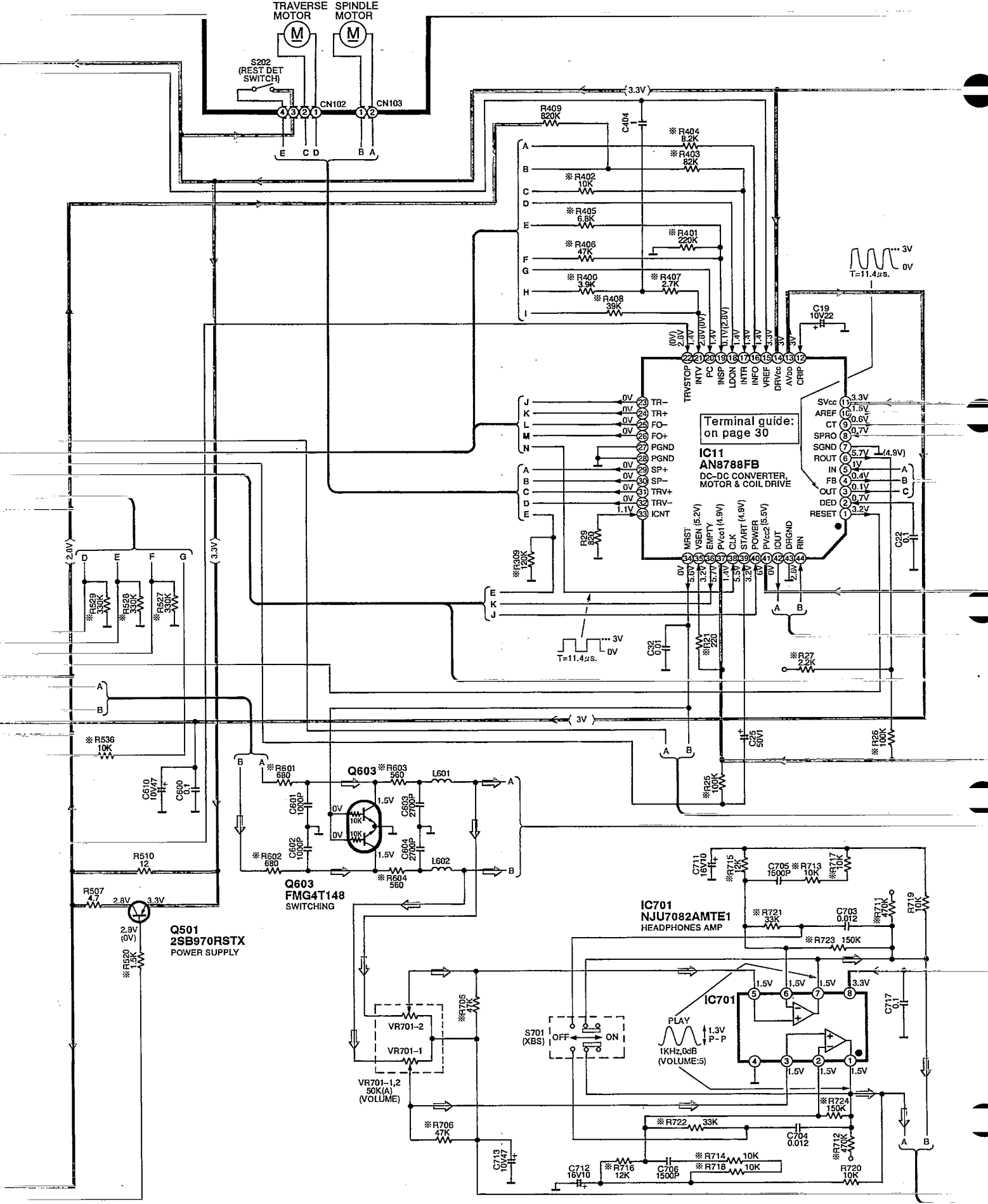

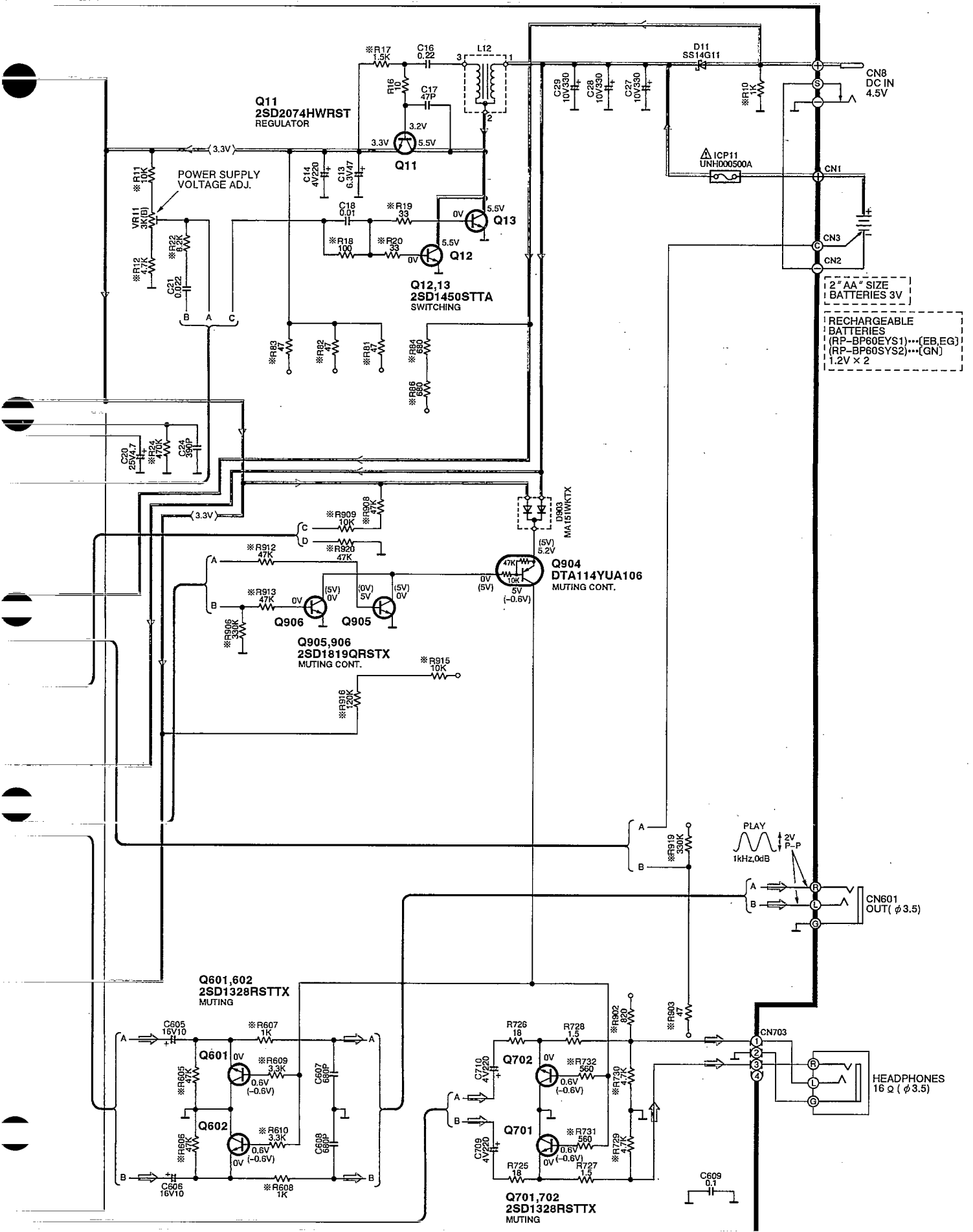

Printed Circuit Board and Wiring Connection Diagram

Notes:

- In this printed circuit board diagram, the parts and foil patterns on the board facing toward you are printed in black. The opposite side is printed in blue.
- The "●" mark denotes the connection points of double-faced foil patterns (through holes) on both sides of the printed circuit board.
- This printed circuit board diagram may be modified at any time with the development of new technology.

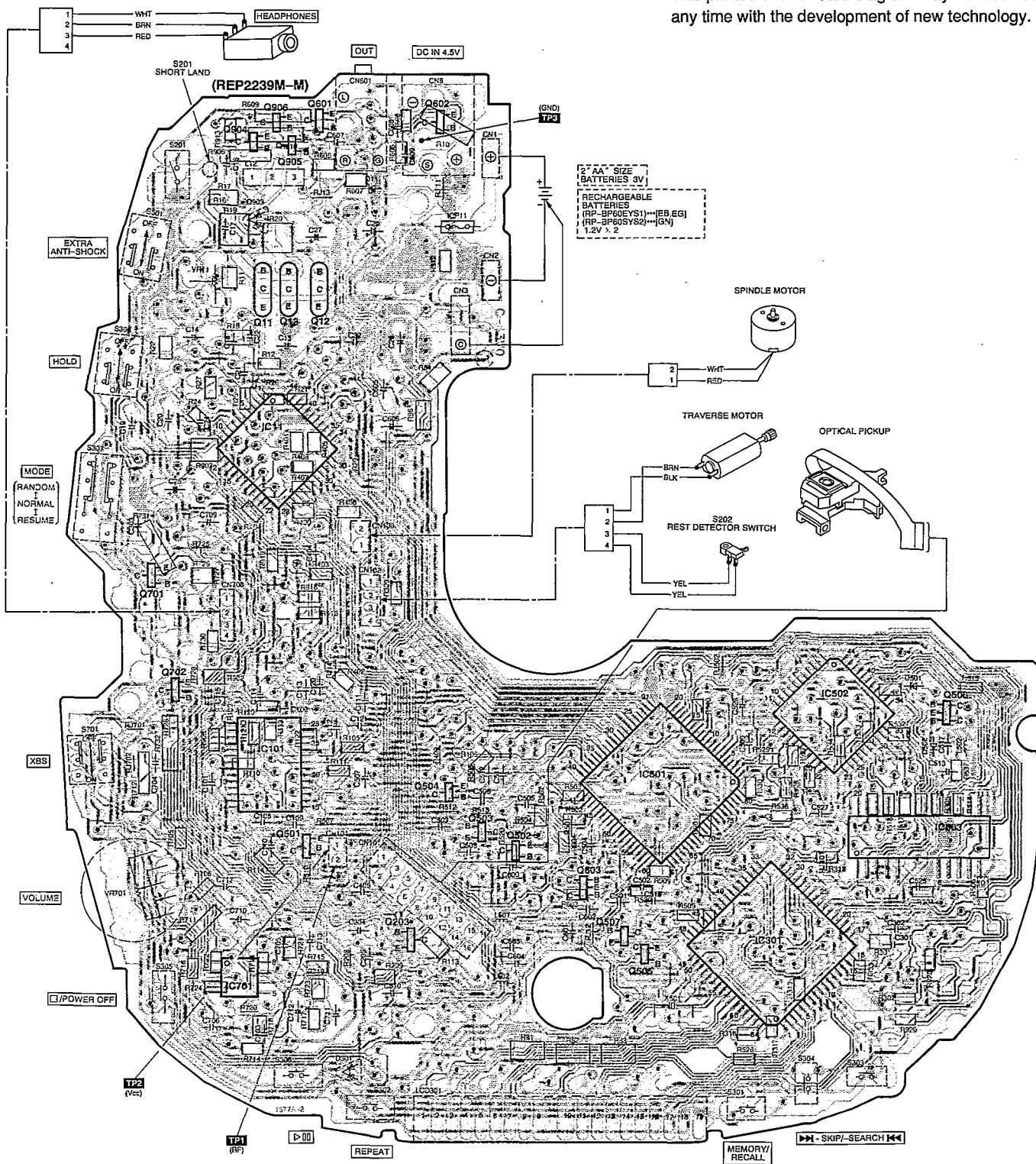

■ Repairing the Printed Resistor

This unit uses a printed resistor for the printed circuit board. If the printed resistor is insulated, all maintenance should be done with reference to the following repair parts connection diagram and repair parts list.

Note: Reading the repair parts connection diagram.

- The pattern foil and repair parts are printed in blue.
- The connection points (•—W—•) for the pattern foil and repair parts are printed in black.

Replacement Parts List		
Ref.No.	Parts No.	Value & Remarks
R10	ERDS2TJ102	1/4W, 1kΩ
R11	ERDS2TJ103	1/4W, 10kΩ
R12	ERDS2TJ472	1/4W, 4.7kΩ
R17	ERDS2TJ152	1/4W, 1.5kΩ
R18	ERDS2TJ101	1/4W, 100Ω
R19	ERDS2TJ330	1/4W, 33Ω
R20	ERDS2TJ330	1/4W, 33Ω
R21	ERDS2TJ221	1/4W, 220Ω
R22	ERDS2TJ822	1/4W, 8.2kΩ
R24	ERDS2TJ474	1/4W, 470kΩ
R25	ERDS2TJ104	1/4W, 100kΩ
R26	ERDS2TJ104	1/4W, 100kΩ
R27	ERDS2TJ222	1/4W, 2.2kΩ
R81	ERDS2TJ470	1/4W, 47Ω
R82	ERDS2TJ470	1/4W, 47Ω
R83	ERDS2TJ470	1/4W, 47Ω
R84	ERDS2TJ681	1/4W, 680Ω
R86	ERDS2TJ681	1/4W, 680Ω
R113	ERDS2TJ101	1/4W, 100Ω
R114	ERDS2TJ330	1/4W, 33Ω
R609	ERDS2TJ332	1/4W, 3.3kΩ
R610	ERDS2TJ332	1/4W, 3.3kΩ
R711	ERDS2TJ474	1/4W, 470kΩ
R712	ERDS2TJ474	1/4W, 470kΩ
R731	ERDS2TJ561	1/4W, 560Ω
R732	ERDS2TJ561	1/4W, 560Ω
R903	ERDS2TJ470	1/4W, 47Ω
R906	ERDS2TJ334	1/4W, 330kΩ
R908	ERDS2TJ473	1/4W, 47kΩ
R916	ERDS2TJ124	1/4W, 120kΩ

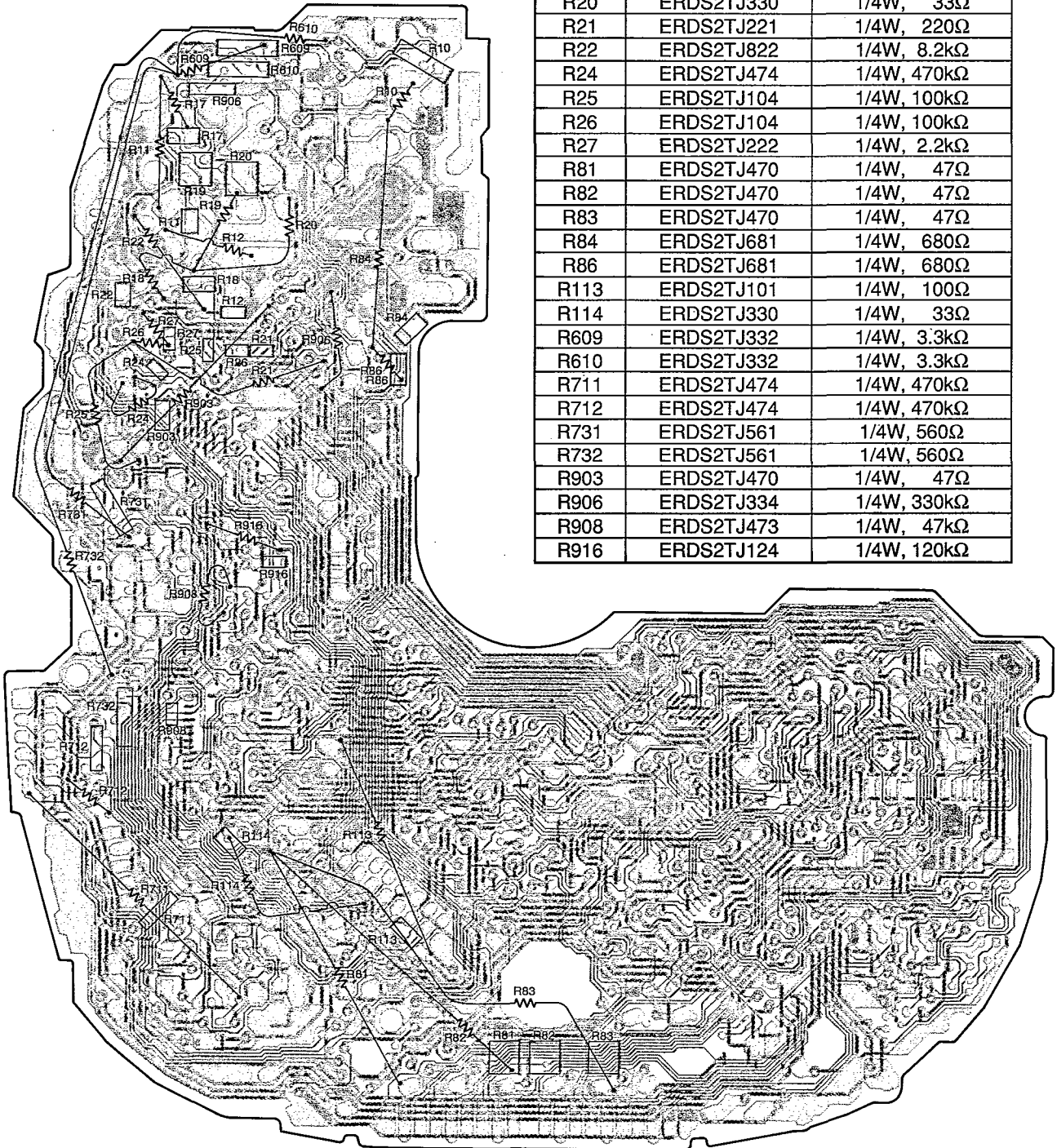

Terminal Guide

• IC501 (MN662745RPC): Servo processor/Digital signal processor/Digital filter/D/A converter

Pin No.	Mark	I/O Division	Function
1	BCLK	O	Serial bit clock output
2	LRCK	O	L/R discriminating signal output
3	SRDATA	O	Serial data signal output
4	DVDD1	I	Power supply (digital circuit) terminal
5	DVSS1	—	GND (digital circuit) terminal
6	TX	—	Digital audio interface signal (Not used, open)
7	MCLK	I	Command clock signal
8	MDATA	I	Command data signal
9	MLD	I	Command load signal ("L" : LOAD)
10	SENSE	—	Sense signal (OFT, FESL, NACEND, NAJEND, POSAD, SFG) (Not used, open)
11	FLOCK	—	Optical servo condition (focus) ("L" : lead-in) (Not used, open)
12	TLOCK	—	Optical servo condition (tracking) ("L" : lead-in) (Not used, open)
13	BLKCK	O	Sub-code block clock (f=75 Hz)
14	SQCK	I	Sub-code Q register clock
15	SUBQ	O	Sub-code Q data
16	DMUTE	I	Muting input ("H" : MUTE) (Not used, connected to GND)
17	STAT	O	Status signal (CRC, CUE, CLVS, TTSTOP, FCLV, SQCK)
18	RESET	I	Reset signal ("L" : reset)
19	SMCK	O	System clock (f=4.2336 MHz)
20	PMCK	O	Frequency division clock signal ($f = \frac{1}{1.92} \times ck = 88.2 \text{ kHz}$)
21	TRV	O	Traverse servo control

Pin No.	Mark	I/O Division	Function
22	TVD	O	Traverse drive signal
23	PC	O	Turntable motor drive signal ("L" : ON)
24	ECM	O	Turntable motor drive signal (Forced mode)
25	ECS	O	Turntable motor drive signal (Servo error signal)
26	KICK	O	Kick pulse output
27	TRD	O	Tracking drive signal output
28	FOD	O	Focus drive signal output
29	VREF	I	D/A drive output (TVD, ECS, TRD, FOD, FBAL, TBAL) normal voltage input terminal
30	FBAL	O	Focus balance adj. output (Not used, open)
31	TBAL	O	Tracking balance adj. output
32	FE	I	Focus error signal (analog input)
33	TE	I	Tracking error signal (analog input)
34	RFENV	I	RF envelope signal
35	VDET	I	Oscillation det. signal ("H" : det.)
36	OFTR	I	Off track signal ("H" : Off track)
37	TRCRS	I	Track cross signal input
38	RFDET	I	RF detection signal ("L" : detection)
39	BDO	I	Dropout detection signal ("H" : dropout)
40	LDON	O	Laser power control ("H" : ON)
41	TES	—	Tracking error shunt output ("H" : dropout) (Not used, open)
42	PLAY	—	Play signal ("H" : play) (Not used, open)

Pin No.	Mark	I/O Division	Function
43	WVEL	—	Double velocity status signal ("H" : double) (Not used, open)
44	ARF	I	RF signal input
45	IREF	I	Reference current input
46	DRF	—	DSL bias terminal (Not used, connected to GND)
47	DSLFL	O	DSL loop filter terminal
48	PLLF	I	PLL loop filter terminal
49	VCOF	I	VCO loop filter terminal (Not used, connected to AVDD2)
50	AVDD2	I	Power supply (analog circuit) terminal (2)
51	AVSS2	—	GND (analog circuit) terminal
52	FS384	—	384 fs (16.9344 MHz) output (Not used, open)
53	PCK	—	PLL extract clock (f=4.3218 MHz) (Not used, open)
54	TROF	—	Tracking servo OFF signal (Not used, open)
55	SUBC	—	Sub-code serial output data (Not used, open)
56	SBCK	—	Sub-code serial input clock (Not used, connected to GND)
57	VSS	—	GND terminal
58	X1	I	Crystal oscillator terminal (f=16.9344 MHz)
59	X2	O	
60	VDD	I	Power supply terminal
61	TRVSTOP	O	Traverse motor stop control terminal
62	CLDCK	—	Sub-code frame clock signal (f CLDCK=7.35 kHz: Normal) (Not used, open)

Pin No.	Mark	I/O Division	Function
63	FCLK	—	Crystal frame clock (Not used, open)
64	IPFLAG	—	Interpolation flag terminal
65	FLAGO	—	Flag terminal
66	CLVS	—	Turntable servo phase synchro signal ("H" : CLV, "L" : Rough servo) (Not used, open)
67	CRC	—	Sub-code CRC check terminal ("H" : OK, "L" : NG) (Not used, open)
68	DEMPHA	—	De-emphasis ON signal ("H" : ON) (Not used, open)
69	FLAG6	—	Flag terminal
70	SEL	—	Not used, connected to GND
71	TEST	I	Test terminal (Normal: "H")
72	AVDD1	I	Power supply (analog circuit) terminal (1)
73	OUTL	O	Lch audio signal
74	AVSS1	—	GND (analog circuit) terminal (1)
75	OUTR	O	Rch audio signal
76	RSEL	I	Polarity direction control terminal of RF signal (Not used, connected to power supply)
77	CSEL	I	Frequency control terminal of crystal oscillator (Not used, connected to GND)
78	ISRDATA	I	Serial data signal input
79	ILRCK	I	L/R discriminating signal input
80	IBCLK	I	Serial bit clock input

● IC11 (AN8788FB): DC-DC converter & motor drive

Pin No.	Mark	I/O Division	Function
1	RESET	O	Reset signal input terminal
2	DED	I	Dead time input terminal
3	OUT	O	DC-DC converter output terminal
4	FB	O	Error amp output terminal
5	IN	I	Error amp input terminal
6	ROUT	O	Remote control interface output terminal
7	SGND	—	GND terminal
8	SPRO	I	Short protection input terminal
9	CT	I	Triangular wave oscillator terminal
10	AREF	O	1/2 AVDD output terminal
11	SV _{CC}	I	Power supply terminal
12	CRIP	I	Capacitor connection terminal for ripple filter
13	AV _{DD}	O	Ripple filter output terminal
14	DRV _{CC}	I	Power supply terminal
15	VREF	I	1/2 VCC input terminal
16	INFO	I	Focus coil drive input terminal
17	INTR	I	Tracking coil drive input terminal
18	LDON	I	Laser ON/ OFF drive control terminal
19	INSP	I	Spindle motor drive input terminal
20	PC	I	Spindle motor drive ON/OFF control terminal
21	INTV	I	Traverse motor drive control terminal
22	TRVSTOP	I	Traverse motor ON/ OFF control terminal

Pin No.	Mark	I/O Division	Function
23	TR-	O	Tracking coil drive output terminal
24	TR+		
25	FO-	O	Focus coil drive output terminal
26	FO+		
27 28	PGND	—	GND terminal
29	SP+	O	Spindle motor drive output terminal
30	SP-		
31	TRV+	O	Traverse motor drive output terminal
32	TRV-		
33	ICNT	I	Rechargeable current setting terminal
34	MRST	O	Muting reset output terminal
35	VSEN	I	Empty det. input terminal
36	EMPTY	O	Empty det. output terminal
37	PV _{CC1}	I	Power supply terminal
38	CLK	I	External synch. clock input terminal
39	START	I	Start oscillator input terminal
40	POWER	I	Power ON/ OFF input terminal
41	PV _{CC2}	I	Power supply terminal
42	I OUT	O	Rechargeable and battery det. terminal
43	DRGND	—	GND terminal
44	RIN	I	Remote control signal input terminal

● IC301 (SC440301FU): System control/LCD drive

Pin No.	Mark	I/O Division	Function
1 └ 6	FP6 └ FP1	O	LCD segment signal output terminal
7	BP3/FP0		
8 └ 10	BP2 └ BP0		
11 └ 13	VLCD3 └ VLCD1	I	Voltage control input terminal
14	V _{DD}	I	Power supply terminal
15	OSC1	I	Main system clock input terminal
16	OSC2	—	Not used, open
17	XOSC2	—	Not used, open
18	XOSC1	—	Not used, connected to GND
19	V _{SS}	—	GND terminal
20	RESET	O	Reset signal output terminal
21	STAT	I	Status signal input (CRC, CUE, CLVS, TT STOP, FCLV, SQOK)
22	BLKCK	I	Sub-code block clock (F=75Hz with normal play)
23	SUBQ	I	Sub-code Q data input terminal
24	SQCK	O	Sub-code Q register clock signal output terminal
25	MEMORY	I	Key switch input terminal (MEMORY)
26	REPEAT	I	Key switch input terminal (REPEAT)
27	STOP	I	Key switch input terminal (STOP)
28	PLAY	I	Key switch input terminal (PLAY/PAUSE)
29	RESUME	I	Key switch input terminal (RESUME)
30	RANDOM	I	Key switch input terminal (RANDOM)
31	HOLD	I	Key switch input terminal (HOLD)
32	EMPTY	I	Empty det. input terminal

Pin No.	Mark	I/O Division	Function
33	OPEN	I	Disc holder open det. terminal ("L" with open)
34	SKIP. R	I	Key switch input terminal (SKIP/SEARCH. R)
35	SKIP. F	I	Key switch input terminal (SKIP/SEARCH. F)
36	WRDRCN/ RSENSE	I/O	Remote control signal terminal
37	BUZ	O	Beep control signal output terminal
38	MODE2	—	Not used, connected to GND
39	POWER	O	Power ON/OFF signal output terminal
40	MUTE	O	Muting signal output terminal ("H" : mute)
41	MLD	O	Command load signal output terminal ("L" : load)
42	MDATA/ BATTERY	O	Command data signal output terminal
43	MCLK/ MODE1	O	Command clock signal output terminal
44	REST	I	Rest det. input terminal
45	RCLK/ STROBE1	O	Remote control clock signal output terminal
46	RDATA/ STROBE2	I/O	Remote control data signal terminal
47	ACDET	I	Power det. input terminal
48	CHARGE/ LIGHT	—	Not used, open
49	LCDREM	—	Not used, open
50	SHOCK. P	I	Key switch input terminal (not used connected to power supply)
51	ZSENSE	I	Sense signal input terminal
52	VUP	O	Reference current control output terminal
53 └ 54	FP18 └ FP17	—	Not used, open
55 └ 63	FP16 └ FP8	O	LCD segment signal output terminal
64	FP7	—	Not used, open

● IC502 (SM5856A1F) : Shock proof controller

Pin No.	Mark	I/O Division	Function
1	V _{DD} 1	I	Power supply terminal
2	UC1	I	Key input terminal (ANTI-SHOCK MEMORY)
3	XBS	—	Key input terminal (Not used, open)
4	BASS	—	Not used, open
5	ASC	—	Sound quality/sound field control terminal (Not used, open)
6	UC5	O	Sound quality/sound field control terminal
7	NTEST1	—	Test terminal (Not used, open)
8	NTEST2		
9	CLK	I	Clock signal input (f=16.9344MHz)
10	V _{SS}	—	GND terminal
11	YSRDATA	I	Serial data input terminal
12	YLCK	I	L/R clock input terminal
13	YSCK	I	Serial bit clock input terminal
14	ZSCK	O	Serial bit clock output terminal
15	ZLCK	O	L/R clock output terminal
16	ZSRDATA	O	Serial data output terminal
17	YFLAG	I	RAM over-flow flag terminal

Pin No.	Mark	I/O Division	Function
18	YFCLK	I	Crystal frame clock input
19	YBLKCK	I	Sub-cord block clock input terminal
20	RESET	I	Reset input terminal
21	ZSENSE	O	Microcomputer states output terminal
22	RAMSEL	I	Not used, open
23	YDMUTE	I	Mute input terminal
24	YMLD	I	Microcomputer latch clock input terminal
25	YMDATA	I	Microcomputer serial data input terminal
26	YMCLK	I	Microcomputer shift clock input terminal
27	NOE	O	D-RAM output enable terminal
28	NCAS	O	D-RAM column address strobe terminal
29 ┆ 32	D0 ┆ D3	I/O	D-RAM data input/output terminal
33	NWE	O	D-RAM write enable terminal
34	NRAS	O	D-RAM low address strobe terminal
35 ┆ 44	A0 ┆ A9	O	D-RAM address output terminal

● IC503 (MN41440CSJ7T) : 4M DRAM

Pin No.	Mark	I/O Division	Function
1	D0	I/O	Data input/output terminal
2	D1	I/O	Data input/output terminal
3	NWE	I	Write enable terminal
4	NRAS	I	Low address strobe terminal
5	A9	I	Address input terminal
6	A0	I	Address input terminal
7 ┆ 9	A1 ┆ A3	I	Address input terminal

Pin No.	Mark	I/O Division	Function
10	VCC	I	Power supply terminal
11 ┆ 15	A4 ┆ A8	I	Address input terminal
16	NOE	I	Output enable terminal
17	NCAS	I	Column address strobe terminal
18	D3	I	Data input terminal
19	D2	I	Data input terminal
20	GND	—	GND terminal

● IC101 (AN8837SBE1): Servo amp.

Pin No.	Mark	I/O Division	Function
1	PDE	I	Tracking signal input terminal (1)
2	PDF	I	Tracking signal input terminal (2)
3	Vcc	I	Power supply terminal
4	PDA	I	Focus signal input terminal (1)
5	PDB	I	Focus signal input terminal (2)
6	LPD	I	APC amp input terminal
7	LD	O	APC amp output terminal
8	RF	O	RF summing output terminal
9	RF IN	I	RF signal input terminal
10	CSBRT	O	Capacitor connection terminal for OFTR
11	CEA	O	Capacitor connection terminal for H.P.F. amp
12	BDO	O	Dropout signal output terminal ("H" : Dropout)
13	LDON	I	APC control input terminal
14	GND	—	GND terminal

Pin No.	Mark	I/O Division	Function
15	/RFDET	O	RF det. signal output terminal ("L" : Det.)
16	CROSS	O	Track cross signal output terminal
17	OFTR	O	Off track signal output terminal ("H" : Off track)
18	VDET	O	Vibration det. signal output terminal ("H" : Det.)
19	ENV	O	RF envelope signal output terminal
20	ENV OFF	I	ENV control input terminal
21	TEBPF	I	VDET input terminal
22	TE IN	I	Tracking error amp input terminal
23	TE OUT	O	Tracking error amp output terminal
24	FE OUT	O	Focus error amp output terminal
25	FE IN	I	Focus error amp input terminal
26	VREF	O	Reference voltage output terminal
27	TBAL	I	Tracking balance signal input terminal
28	FBAL	I	Focus balance signal input terminal

Cabinet Parts Location

Note: When changing loading mechanism parts, apply the specified grease to the areas marked "XX" as shown in the drawing.

Ref. No.	Part No.
A	RFKXPG671

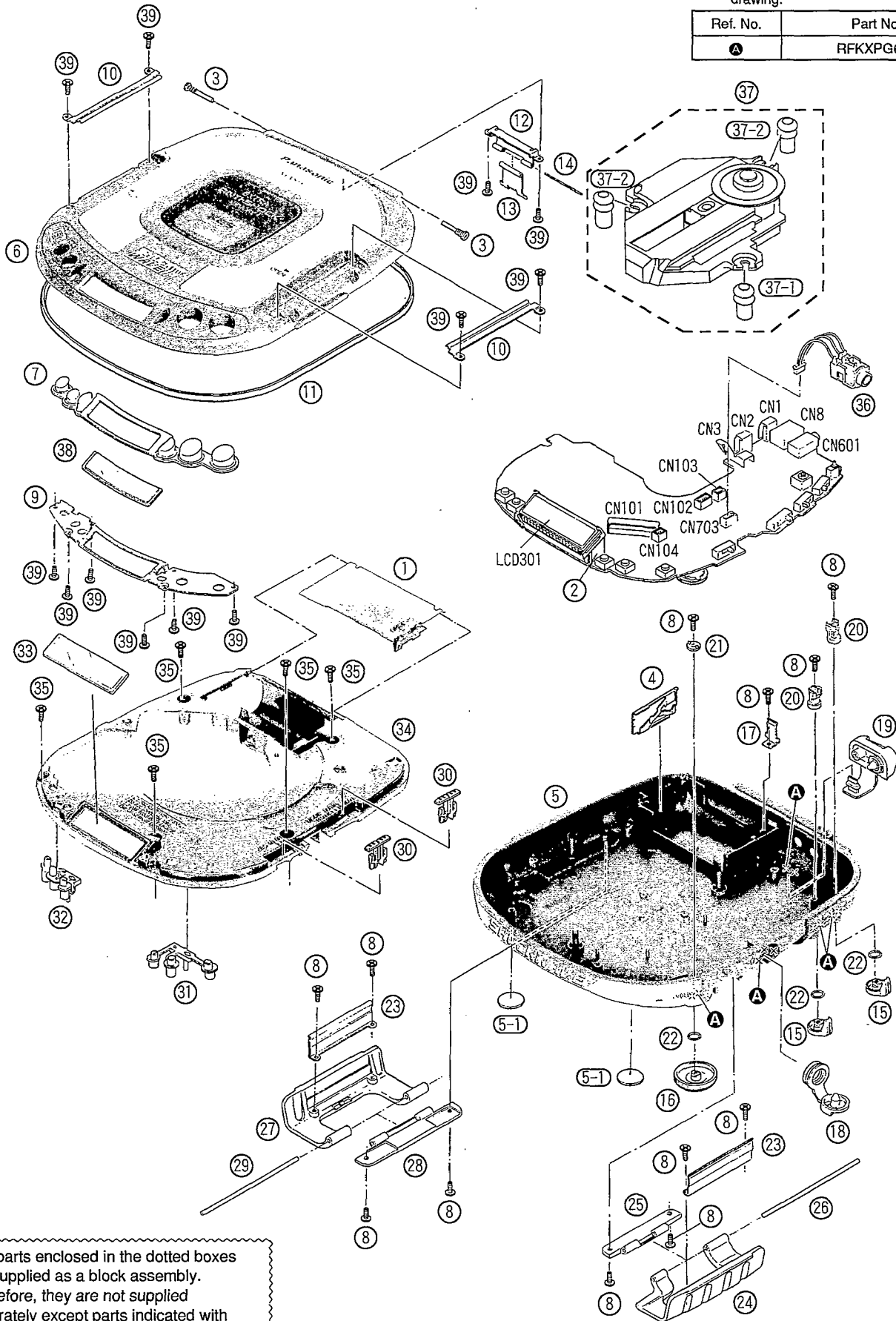

The parts enclosed in the dotted boxes are supplied as a block assembly. Therefore, they are not supplied separately except parts indicated with Ref. No.

Replacement Parts List

Notes: * Important safety notice:

 Components identified by Δ mark have special characteristics important for safety.

Furthermore, special parts which have purposes of fire-retardant (resistors), high-quality sound (capacitors), low-noise (resistors), etc. are used.

When replacing any of components, be sure to use only manufacturer's specified parts shown in the parts list.

* The parenthesized indications in the Remarks columns specify the areas. (Refer to the cover page for area.)

Parts without these indications can be used for all areas.

* Warning: This product uses a laser diode. Refer to caution statements on page 2.

* ACHTUNG: Die Lasereinheit nicht zerlegen.

Die Lasereinheit darf nur gegen eine vom Hersteller spezifizierte Einheit ausgetauscht werden.

Ref. No.	Part No.	Part Name & Description	Remarks	Ref. No.	Part No.	Part Name & Description	Remarks
		CABINET AND CHASSIS		38	RKW0456-Q	LCD PANEL (A)	
				39	RHE5119YA	SCREW	
1	RKK0096-K	BATTERY COVER				INTEGRATED CIRCUIT(S)	
2	RJF0026	LCD HOLDER		IC11	AN8788FB	IC	
3	RHD20039-K	SCREW		IC101	AN8837SBE1	IC	
4	RJC93020	COMMON BATTERY TERMINAL		IC301	SC440301FU	IC	
5	RFKJLSW404EB	BOTTOM CABINET ASS'Y	(EB)	IC501	MN662745RPC	IC	
5	RFKJLSW404EG	BOTTOM CABINET ASS'Y	(EG)	IC502	SM5856A1F	IC	
5	RFKJLSW404GN	BOTTOM CABINET ASS'Y	(GN)	IC503	MN41440CSJ7T	IC	
5-1	RKA0063-K	FOOT		IC701	NJU7082AMTE1	IC	
6	RFKLLSW404PA	CD COVER ASS'Y				TRANSISTOR(S)	
7	RGU1414-D	OPERATION BUTTON		Q11	2SD2074HWRST	TRANSISTOR	
8	RHE5079YA	SCREW		Q12, 13	2SD1450STTA	TRANSISTOR	
9	RKU0071-K	BUTTON COVER		Q203	2SB709QRSTX	TRANSISTOR	
10	RMA0961	BUCKLE ORNAMENT(B)		Q501	2SB970RSTX	TRANSISTOR	
11	RMG0424-D	CABINET WATER PROOF RING		Q502	UN5113TX	TRANSISTOR	
12	RMA0959	STOPPER ANGLE		Q503, 504	UN5211TX	TRANSISTOR	
13	RMA0984	LOCK ANGLE		Q505	UN5215TX	TRANSISTOR	
14	RMS0550	STOPPER SHAFT		Q506	FMW1T98	TRANSISTOR	
15	RGV0173-H	HOLD/EXTRA ANTI-SHOCK KNOB		Q507	DTA143TUT107	TRANSISTOR	
16	RGW0250-H	VOLUME KNOB		Q601, 602	2SD1328QRSTX	TRANSISTOR	
17	RMCO306	OPEN SPRING		Q603	FMG4T148	TRANSISTOR	
18	RMG0425-H	WATER PROOF COVER(A)		Q701, 702	2SD1328QRSTX	TRANSISTOR	
19	RMG0426-H	WATER PROOF COVER(B)		Q904	DTA114YUA106	TRANSISTOR	
20	RML0452	OPERATION LEVER		Q905, 906	2SD1819QRSTX	TRANSISTOR	
21	RML0453	VOLUME LEVER				DIODE(S)	
22	RMX0122	WATER PROOF RING		D11	SS14G11	DIODE	
23	RMA0960	BUCKLE ORNAMENT(A)		D301	MA151WKTX	DIODE	
24	RMRI002-K	BUCKLE (A)		D501	MA8047MTX	DIODE	
25	RMRI003-K	BUCKLE SHAFT PLATE (A)		D502	1SS355TE17	DIODE	
26	RMS0544	BUCKLE SHAFT (A)		D903	MA151WKTX	DIODE	
27	RMRI002A-K	BUCKLE (B)				IC PROTECTOR(S)	
28	RMRI003A-K	BUCKLE SHAFT PLATE (B)		ICP11	UNH000500A	IC PROTECTOR	Δ
29	RMS0544A	BUCKLE SHAFT (B)				VARIABLE RESISTOR(S)	
30	RGV0172-K	MODE/XBS KNOB		VR11	EVNDXAA00B33	V. R	
31	RGZ0030-K	OPERATION KEY TOP(A)					
32	RGZ0031-K	OPERATION KEY TOP(B)					
33	RKW0457-K	LCD PANEL (B)					
34	RMK0333	INTERMEDIATE CHASSIS					
35	XTN17+6GFZ	SCREW					
36	REX0818	HEADPHONES JACK ASS'Y					
37	RAE0141Z	TRAVERSE DECK	Δ				
37-1	SHGD157	FLOATING RUBBER(1)					
37-2	SHGD165	FLOATING RUBBER(2)					

Ref. No.	Part No.	Part Name & Description	Remarks	Ref. No.	Part No.	Part Name & Description	Remarks
VR701	EVUTOVA05A54	V. R					
		COIL (S)				PACKING MATERIAL	
L12	RL20028T-0	COIL		P1	RPK0754	PACKING CASE	
L502	RLQU331KT-W	COIL		P2	RPQ0654	SPACER	(EB, EG)
L601, 602	RLB0003	COIL		P2	RPQ0657	SPACER	(GN)
		OSCILLATOR (S)		P3	RPF0111	PROTECTION BAG (UNIT)	
X501	RSXZ16M9M01T	OSCILLATOR		P4	RPF0046	PROTECTION BAG (F. B.)	
		LCD (S)		P5	RPQ0638	PAD	
LCD301	RSL5156-L	LCD				ACCESSORIES	
		SWITCH (ES)		A1	RQT3534-B	INSTRUCTION MANUAL	(EB, GN)
S201	ESE11SV1	SW		A1	RFKLSW404EG	INSTRUCTION MANUAL ASS' Y	(EG)
S202	SSH1-2	SW		A2	RFEA404B-1W	AC ADAPTOR	△ (EB)
S301-306	EVQ21405R	SW		A2	RFEA401E-2S	AC ADAPTOR	△ (EG)
S307	ESD11H230	SW		A2	RFEA403A-S	AC ADAPTOR	△ (GN)
S308	ESD11H220	SW		A3	RFEV701P-AS	STEREO HEADPHONES	
S501	ESD11H220	SW		A4	RQA0117	WARRANTY CARD	(EB, EG)
S701	ESD11H220	SW		A4	RQX7433ZA	WARRANTY CARD	(GN)
		CONNECTOR (S) AND JACK (S)		A5	RQC80169	SERVICENTER LIST	
CN1	RJC93015-1	BATTERY TERMINAL (+)		A6	RP-BP60EYS1	RECHARGEABLE BATTERY	(EB, EG)
CN2	RJC93015-1	BATTERY TERMINAL (-)		A6	RP-BP60SYS2	RECHARGEABLE BATTERY	(GN)
CN3	RJR0166	RECHARGEABLE BATT. TERMINAL		A6-1	RFKNLS370-K	BATTERY CARRING CASE	
CN8	RJJ43K09-C	DC IN JACK				<PRINTED CIRCUIT BOARD ASS' Y>	
CN101	RJU035T016-1	SOCKET (16P)		PCB1	REP2239M-M	MAIN P. C. B. ASS' Y	(RTL)
CN102	RJT068W04V	CONNECTOR (4P)				<GREASE OR JIG/TOOL>	
CN103, 104	RJT068W02V	CONNECTOR (2P)				TEST DISC	
CN601	RJJD3S5ZB-C	OUT JACK		SA1	SZZP1054C	PLAYABILITY TEST DISC	
CN703	RJT068W04V	CONNECTOR (4P)		SA2	SZZP1056C	UNEVEN TEST DISC	
						GREASE	
				SA3	RFKXPG671	MOLYCOAT GREASE PG671	

Note: • The marking (RTL) indicates that the Retention Time is limited for this item. After the discontinuation of this assembly in production, the item will continue to be available for a specific period of time. The retention period of availability is dependant on the type of assembly, and in accordance with the laws governing part and product retention. After the end of this period, the assembly will no longer be available.

Resistors and Capacitors

Notes: * Capacity values are in microfarads (uF) unless specified otherwise, P=Pico-farads (pF) F=Farads (F)
 * Resistance values are in ohms, unless specified otherwise, 1K=1,000 (OHM), 1M=1,000k (OHM)

Ref. No.	Part No.	Values & Remarks	Ref. No.	Part No.	Values & Remarks	Ref. No.	Part No.	Values & Remarks
		RESISTORS	C16	ECUVNC224KBN	16V 0.22U	C503	ECUV1H561KBN	50V 560P
			C17	ECUV1H470KCN	50V 47P	C504	ECUV1C473KBN	16V 0.047U
			C18	ECUV1E103KBN	25V 0.01U	C505	ECUV1E223KBN	25V 0.022U
R16	ERJ6GEYJ100	1/10W 10	C19	ECEA1AKA220I	10V 22U	C506	ECUVNC474KBN	16V 0.47U
R29	ERJ6GEYJ821V	1/10W 820	C20	ECEA1EKA4R7I	25V 4.7U	C507	ECEA0GKA22I	4V 220U
R208	ERJ6GEYJ4R7V	1/10W 4.7	C21	ECUV1E223KBN	25V 0.022U	C508, 509	ECUVNE104ZFN	25V 0.1U
R409	ERJ6GEYJ824V	1/10W 820K	C22	ECUVNE104KBN	25V 0.1U	C511	ECUVNC474KBN	16V 0.47U
R501	ERJ6GEYJ683V	1/10W 68K	C24	ECUV1H391KBN	50V 390P	C512	ECUV1E103KBN	25V 0.01U
R504	ERJ6GEYJ474V	1/10W 470K	C25	ECEA1HKA010I	50V 1U	C513	RCST1AY475RE	10V 4.7U
R505	ERJ6GEYJ221V	1/10W 220	C27-29	RCE1AMT331IV	10V 330U	C517	ECUVNE104ZFN	25V 0.1U
R507	ERJ6GEYJ4R7V	1/10W 4.7	C32	ECUV1E103KBN	25V 0.01U	C518	ECUV1E103KBN	25V 0.01U
R510	ERJ6GEYJ120V	1/10W 12	C101	ECUVNE104KBN	25V 0.1U	C525	ECUVNE104ZFN	25V 0.1U
R512	ERJ6GEYJ471V	1/10W 470	C103	ECUV1E273KBN	25V 0.027U	C526	RCST0JY475LE	6.3V 4.7U
R513	ERJ6GEYJ222V	1/10W 2.2K	C108	ECUV1C473KBN	16V 0.047U	C527	ECUVNE104ZFN	25V 0.1U
R719, 720	ERJ6GEYJ103V	1/10W 10K	C109	ECUV1C333KBN	16V 0.033U	C600	ECUVNE104ZFN	25V 0.1U
R725, 726	ERJ6GEYJ180V	1/10W 18	C110	ECUV1E223KBN	25V 0.022U	C601, 602	ECUV1H102KBN	50V 1000P
R727, 728	ERJ6GEYK1R5V	1/10W 1.5	C111	ECUV1E273KBN	25V 0.027U	C603, 604	ECUV1H272KBN	50V 2700P
		CHIP JUMPERS	C112	ECUV1H391KBN	50V 390P	C605, 606	ECEA1CKA100I	16V 10U
			C113, 114	ECUVNE104ZFN	25V 0.1U	C607, 608	ECUV1H681KBN	50V 680P
			C115	ECUV1E223KBN	25V 0.022U	C609	ECUVNE104ZFN	25V 0.1U
RJ11-14	ERJ6GEYOR00V	CHIP JUMPER	C120	ECUV1H332KBN	50V 3300P	C610	RCE1AKA470IG	10V 47U
RJ301	ERJ6GEYOR00V	CHIP JUMPER	C121	ECUV1H221KBN	50V 220P	C703, 704	ECUV1E123KBN	25V 0.012U
RJ502	ERJ6GEYOR00V	CHIP JUMPER	C204	RCE1AKA470IG	10V 47U	C705, 706	ECUV1H152KBN	50V 1500P
RJ701, 702	ERJ6GEYOR00V	CHIP JUMPER	C205	ECUVNE104ZFN	25V 0.1U	C709, 710	ECEA0GPK221I	4V 220U
		CAPACITORS	C301, 302	ECUVNE104ZFN	25V 0.1U	C711, 712	ECEA1CPK100I	16V 10U
			C303	ECUV1E103KBN	25V 0.01U	C713	RCE1AKA470IG	10V 47U
			C404	ECUVNC105ZFN	16V 1U	C717	ECUVNE104ZFN	25V 0.1U
C13	RCE0JSL470IX	6.3V 47U	C405	ECUVNE104KBN	25V 0.1U			
C14	ECEA0GKA22I	4V 220U	C501, 502	ECUV1H150KCN	50V 15P			

Packaging

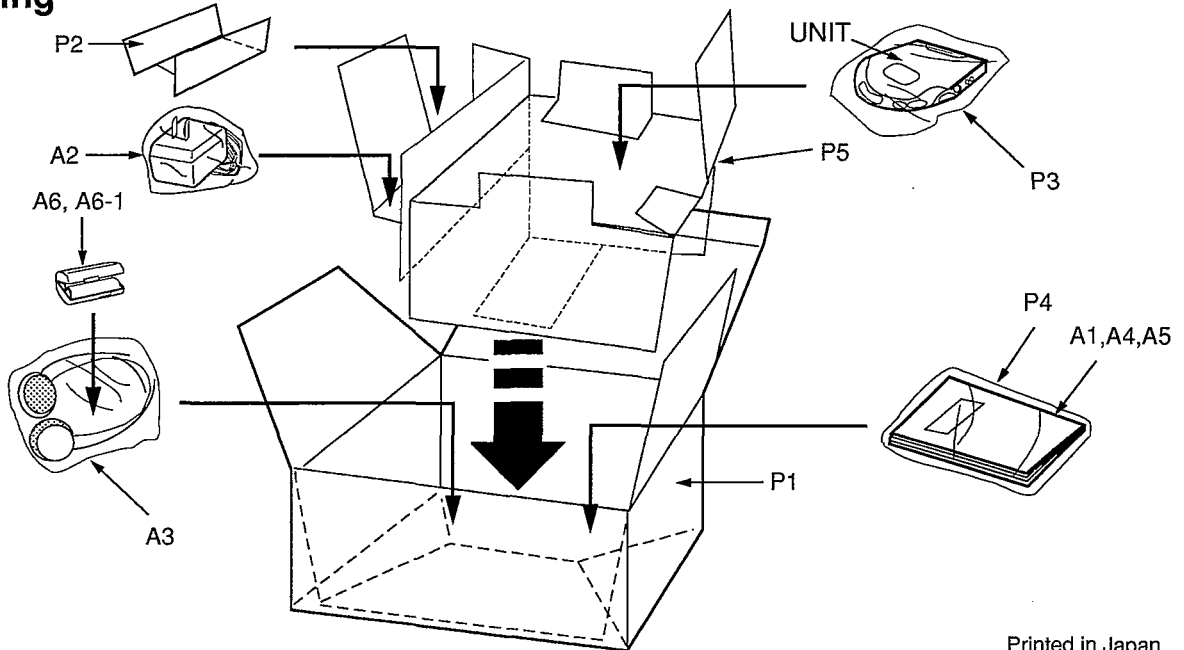

MEMO



MEMO

864