

Service Manual

COMPACT
disc
DIGITAL AUDIO

MASH^{*}
multi-stage noise shaping

※ • MASH is a trademark of NTT.

Portable CD Player

SL-SX300

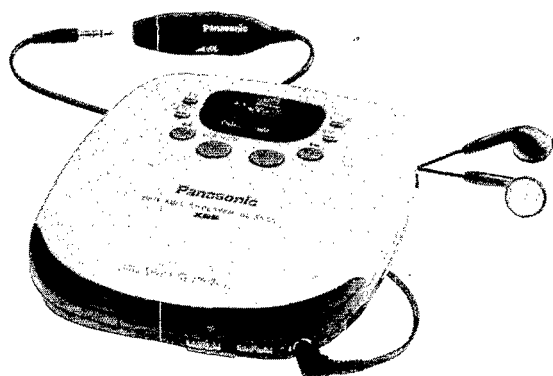

Colour

(A) Blue Type
(S) Silver Type

Areas

EB Great Britain.
EG Germany and
Italy, etc.
GN Oceania.

Areas and Colors

EB (A) (S)
EG (A) (S)
GN (S)

Traverse Deck: RAE0145Z Mechanism Series

Specifications

Audio

No. of channels: 2 channels (left and right, stereo)
Output voltage: 0.6 V (50 kohm)
Frequency response: 20 ~ 20,000 Hz (+0.5 dB, -1.5 dB)
S/N: more than 96 dB*
Wow and flutter: Below measurable limit
DA converter: 1 bit, MASH ※
Headphones output level: max. 9 mW+9 mW/16 ohm (variable)

Pickup

Light source: Semiconductor laser
Wavelength: 780 nm

Play time

(When used in hold mode, at 25 degree (77 fahrenheit) temperature and on flat and stable surface.)

Batteries used	ANTI-SHOCK OFF/ON
2 Alkaline batteries	About 20h/ About 21h
Rechargeable batteries	About 10h/About 10.5h
4 Alkaline batteries	About 45h/About 48h
2 Rechargeable and 2 Alkaline batteries	About 29h/ About 30h

The play time may be less depending on the operating conditions.

General

Operation temperature range: 0 - 40 degree (32 - 104 fahrenheit)
Rechargeable temperature range: 5 - 40 degree (41 - 104 fahrenheit)
Power supply: DC 4.5 V

Power consumption

Power source	ANTI-SHOCK OFF/ON
When using AC adaptor	3.1 W/3.3 W
When recharging	Approx. 5.9 W

Dimensions: 128(Wide)/25.7(High)/134.5(Depth) mm
(5¹/₁₆" X 1" X 5³/₁₆")

Weight: 225 g (9.0 oz) without batteries
270 g (10.6 oz) with batteries

Recharging time: About 3 h

*These specifications were measured in the ANTI-SHOCK OFF mode.

Note: Specifications are subject to change without notice.
Weight and dimensions are approximate.

⚠ WARNING

This service information is designed for experienced repair technicians only and is not designed for use by the general public. It does not contain warnings or cautions to advise non-technical individuals of potential dangers in attempting to service a product. Products powered by electricity should be serviced or repaired only by experienced professional technicians. Any attempt to service or repair the product or products dealt with in this service information by anyone else could result in serious injury or death.

Panasonic[®]

© 1998 Matsushita Electric Industrial Co., Ltd.
All rights reserved. Unauthorized copying and distribution is a violation of law.

Contents

	Page		Page
Precaution of Laser Diode	2	Checking the Operation Problems on the	
Accessories	3	Traverse Deck (Optical Pickup)	16
Power Supply Preparations	3, 4	Automatic Adjustment Results	
Location of Controls	5	Display Function (Self-check Function)	17, 18
Hold Function	5	Measurements and Adjustments	18, 19
Using the Remote Control	6	Outline of 10-Second Sound Keeper Technique	
Anti-Shock Function	6	Used for Prevention of Sound from Skipping	20
Sequential Play (Basic Play)	7	Type Illustration of IC's, Transistors and Diodes	20
Other Play Methods	8, 9	Schematic Diagram	21 ~ 26
Using the Unit with Optional Accessories	9	Printed Circuit Board and	
Concerning Compact Discs	10	Wiring Connection Diagram	27, 28
Troubleshooting Guide	10	Block Diagram	29 ~ 32
Maintenance	10	Terminal Function of IC's	33 ~ 37
Handling Precautions for Traverse Deck	11	Cabinet Parts Location	38
Operation Checks and		Replacement Parts List	39, 40
Main Component Replacement Procedures	12 ~ 15	Packaging	41

Precaution of Laser Diode

CAUTION: This product utilizes a laser diode with the unit turned "on", invisible laser radiation is emitted from the pickup lens.
Wave length: 780 nm
Maximum output radiation power from pickup: 100 μ W/VDE

Laser radiation from the pickup lens is safety level, but be sure the followings:

1. Do not disassemble the optical pickup unit, since radiation from exposed laser diode is dangerous.
2. Do not adjust the variable resistor on the pickup unit. It was already adjusted.
3. Do not look at the focus lens using optical instruments.
4. Recommend not to look at pickup lens for a long time.

ACHTUNG: Dieses Produkt enthält eine Laserdioden. Im eingeschalteten Zustand wird unsichtbare Laserstrahlung von der Lasereinheit abgestrahlt.

Wellenlänge: 780 nm
Maximale Strahlungsleistung der Lasereinheit: 100 μ W/VDE

Die Strahlung an der Lasereinheit ist ungefährlich, wenn folgende Punkte beachtet werden:

1. Die Lasereinheit nicht zerlegen, da die Strahlung an der freigelegten Laserdioden gefährlich ist.
2. Den werkseitig justierten Einstellregler der Lasereinheit nicht verstellen.
3. Nicht mit optischen Instrumenten in die Fokussierlines blicken.
4. Nicht über längere Zeit in die Fokussierlines blicken.

ADVARSEL: I dette a apparat anvendes laser.

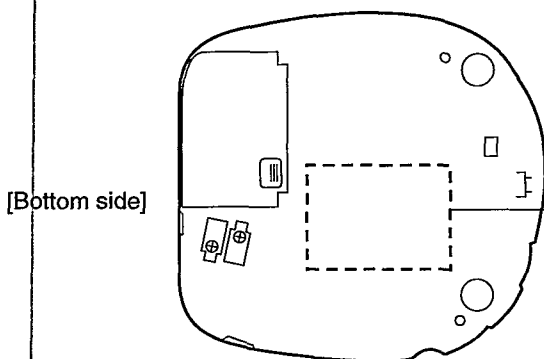

RQLS0196

CLASS 1 LASER PRODUCT		<p>VARO! Avattaessa ja suojalukitus ohitettaessa olet alttiina näkymätön laseriteille. Älä katso säteeseen.</p>
<p>ADVARSEL: USYNLIG LASERSTRÅLING VED ÅBNING, NÅR SIKKERHEDSAFBRYDERE ER UDE AF FUNKTION. UNDGÅ UDSÆTTELSE FOR STRÅLING.</p>		<p>WARNING! Osynlig laserstråling når denna del är öppnad och spärrar är urkopplad. Betrakta ej strålen.</p>
<p>VORSICHT - Unsichtbare Laserstrahlung, wenn Abdeckung geöffnet und Sicherheitsverriegelung überbrückt. Nicht dem Strahl aussetzen.</p>	<p>DANGER - Invisible laser radiation when open and interlock defeated. AVOID DIRECT EXPOSURE TO BEAM.</p>	<p>ADVARSEL! Usynlig laserstråling når deksel åpnes og sikkerhedslås brytes. Unngå eksponering for strålen.</p> <p>A pleine puissance, l'écoute prolongée du baladeur peut endommager l'oreille de l'utilisateur. RQLS0196</p>

Accessories

- AC adaptor 1 pc.
For (EB) area: (RFEA404B-1W)
- For (EG) area: (RFEA401E-3S)
- For (GN) area: (RFEA403A-S)
- Stereo earphones (RFEV316P-K1S) 1 pc.
- Wired remote control (RFEV015PCKS) 1 pc.
- Battery case (RFA0627-K4) 1 pc.

Power Supply Preparations



Refer to the specifications (cover page) for information on operating times when using rechargeable batteries or dry-cell batteries.

Using rechargeable batteries (not included)

Obtain the optional rechargeable batteries. Make sure to recharge the batteries before using them. The unit cannot be used to charge rechargeable batteries other than those specifically designed for it.

- Optional batteries (P-3GAVE/2B, SH-CDB8D)

Recharging procedure

- 1** Insert the special rechargeable batteries into the unit. 
- 2** Connect the AC adaptor. 

 - ④ DC IN jack (DC IN 4.5 V \leftrightarrow \leftrightarrow)
 - ⑤ Back panel of the unit
 - ⑥ AC adaptor
 - ⑦ AC power outlet

When charging is commenced, the charging indicator "G" flashes on the display.

When the rechargeable batteries are fully recharged, the charging indicator disappears.

- 3** When recharging is complete, unplug the AC adaptor from the power outlet and the DC IN jack.

Notes

- Rechargeable batteries have a service life of approximately 300 charge-discharge cycles. If the operating time on one full charge becomes noticeably shorter than it used to be, the battery has reached the end of its service life and should be replaced.
- Recharging may only be performed when the unit is powered off. (It is not possible to recharge the batteries while playing a CD.)
- The AC adaptor and rechargeable batteries may become warm while recharging is in progress. This is not a malfunction.

If the battery lid compartment comes loose  Slide the lid back into place horizontally.

Removing batteries  Push up on the battery in the direction indicated by the arrow. Then lift it out.

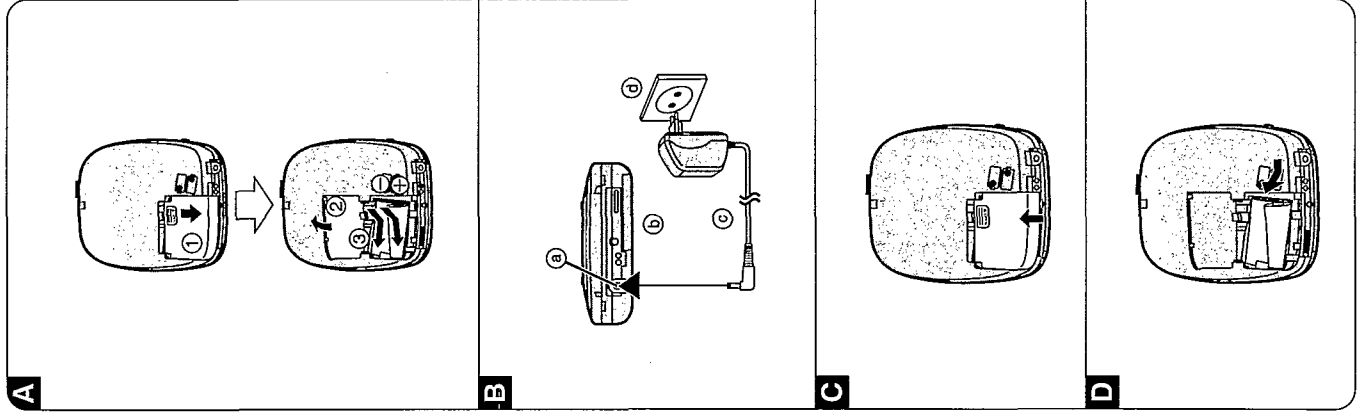

Using the AC adaptor

Connect the AC adaptor supplied. [A]

- Ⓐ DC IN Jack (DC IN 4.5 V ⚡)
- Ⓑ Back panel of the unit
- Ⓒ AC adaptor
- Ⓓ AC power outlet

Note

The unit is in the standby condition when the AC adaptor is connected. The primary circuit is always "live" as long as the AC adaptor is connected to an electrical outlet.

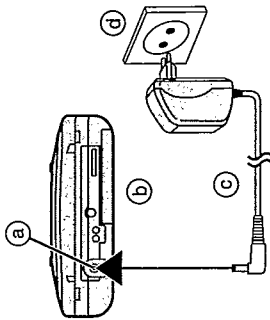

A

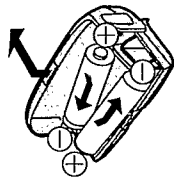

Using dry-cell batteries (not included)

After disconnecting the AC adaptor, insert two LR6 (UM-3) alkaline batteries.

The procedure for inserting and removing dry-cell batteries is identical to that for rechargeable batteries.

Battery indicator [B]

Ⓒ Battery indicator

This indicator flashes on and off when the batteries are almost out of power. Power is cut off completely a short while later.

Rechargeable batteries: Recharge batteries.

Dry-cell batteries: Replace batteries with new ones.

Notes

- The length of time the unit will continue to operate between when the battery indicator starts flashing and when the power is cut off differs depending on the type of batteries used.
- The battery indicator may not flash if rechargeable batteries other than those designated by Panasonic are used.

Using the car adaptor (not included)

Be sure to obtain the car adaptor (SH-CDC9), available as an optional accessory. The car adaptor can be used to recharge the unit's batteries while in the car.

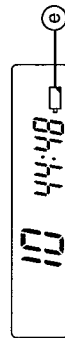

B

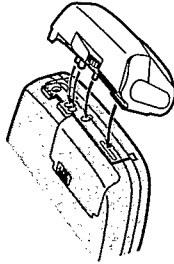

C



D

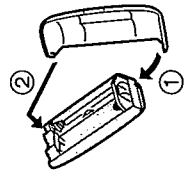

Using the battery case

The battery case allows you to extend the maximum playing time of the unit by loading an additional two LR6 (UM-3) alkaline batteries.

Notes

- When using the battery case, always insert batteries in the unit body as well. (The unit cannot be operated on the batteries in the external battery case alone.)
- Though you can use rechargeable batteries in the battery case, it does not recharge them. (Use dry cell batteries if possible.)
- If rechargeable batteries and dry-cell batteries are used together, make sure to use fully charged rechargeable batteries and new dry-cell batteries.
- When using four dry-cell batteries, do not mix new and old batteries.

1 Open the cover of the battery case and insert the batteries. [A]

Insert the end marked (-) first.

2 Mount the battery case on the unit body. [B]

Insert the protrusions on the battery case into the four indentations in the unit body.

3 Secure in place with the screw. [C]

Reverse the above procedure to remove the external battery case.

For your reference:

The maximum playing time will differ depending on the type of batteries (rechargeable/dry-cell) loaded in the unit body.

[D] If the cover of the battery case comes loose:

Insert the protrusions into the holes on either end of the lid.

If the unit malfunctions or freezes during use, then disconnect the power sources (the AC adaptor and batteries). Re-connect the power source and continue operation.

Location of Controls

A

Portable CD player

- A** Skip/search buttons (◀◀, ▶▶, ▶▶/◀◀, ▶▶▶)
- B** Memory/recall button (MEMORY/RECALL)
- C** EQ button (EQ)
- D** Stop/operation off button (■, POWER OFF)
- E** Play/pause button (▶ ||)
- F** Display
- G** Anti-shock button (ANTI-SHOCK)
- H** Repeat button (REPEAT)
- I** Out jack (OUT)
- J** Headphones volume control (VOLUME)
- K** Headphones jack (⌀)
- L** Play mode selector (RESUME, NORMAL, RANDOM)
- M** Hold switch (HOLD)
- N** Open switch (OPEN)
- O** CD release button (PUSH)
- P** DC in jack (DC IN 4.5 V ⚡)
- Q** Connection terminal for battery case
- R** Hole for car mounting base/battery case

B

Back panel of the unit

- P** DC in jack (DC IN 4.5 V ⚡)
- Q** Connection terminal for battery case
- R** Hole for car mounting base/battery case

B

- A** Plug
- B** Slider

C

- A** Skip/search buttons (+, -)
- B** HOLD switch (HOLD)
- C** Play/stop/off button
- D** Plug
- E** Volume control (VOL)

Hold Function

A

B

This function causes the unit to ignore short, accidental button presses. (The disc lid can still be opened and closed.)

The HOLD function prevents the following:

- Powering on the unit accidentally (which can cause the batteries to go dead).
- Play being cut off unexpectedly in the middle of a section.

The unit and wired remote control have HOLD switches, each of which works independently.

To use the HOLD function
Set HOLD to the HOLD position.

- A** HOLD mode

"ho / d" Indication

When the unit is in hold status, pressing any button causes the indication "ho / d" to appear on the display.

When the unit is powered off

The "ho / d" indication appears only when the ▶ || button is pressed.

■ Anti-Shock Function

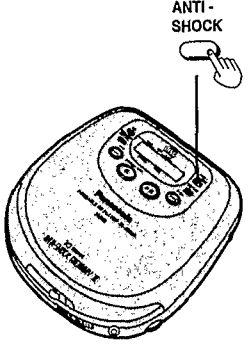

ANTI-SHOCK

A



B

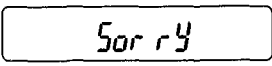

Anti-shock works by reading audio data and storing it in memory (up to 10 seconds worth). The unit then fills in interruptions caused by bumps and vibrations with data from the memory. This unit also incorporates a powerful anti-shock mechanism that prevents skipping caused when play speed is changed by swinging of the unit.

Press ANTI-SHOCK during play or stop mode.

The following indicator appears on the display panel. **A**

When bumps continue repeatedly **B**

The following indicator appears on the display and sound is interrupted.

To cancel anti-shock function

Press ANTI-SHOCK again.

Notes

- The ANTI-SHOCK setting can be changed during play, but this may cause a slight interruption in the sound because the disc's rotation speed changes.
- During the anti-shock operation, the disc rotates at a higher rate than usual in collecting extra audio data. This could result in a slight increase in disc rotation noise.

Listening to sound with the unit connected to an audio system

The anti-shock function incorporates digital signal compression technology. It is recommended that the anti-shock function be canceled if the unit is connected to a home audio system.

■ Using the Remote Control

A

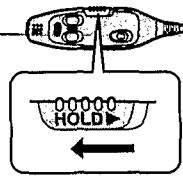

B

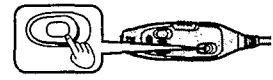

(Beep)

C



(Beep...Beep)

D



(Beep...Beep...p)

E



(Beep Beep)



(Beep Beep Beep)

F



The remote control can be operated regardless of the hold mode of the unit.

■ Operation confirmation tones

When an operation button is pressed, a confirmation tone sounds. Refer to the parentheses in the illustration for the different types of confirmation tones.

How to use the remote control

Preparation:

Release the remote control from the hold mode. **A**

To start play **B**

Press once during off or stop mode.

To stop play **C**

Press once during play.

To turn off the unit **D**

Press and hold during play or stop mode.

Skip forward/backward **E**

Press during play.

+: Forward direction
-: Backward direction

Rapid forward/backward **F**

Press and hold during play.

To adjust the volume **F**

When adjusting the volume using the remote control, position the volume control on the unit to between 4 and 6.

Sequential Play (Basic Play)

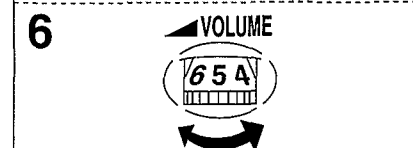
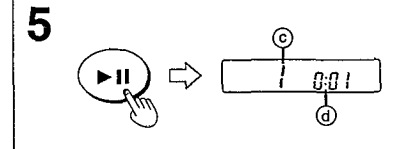
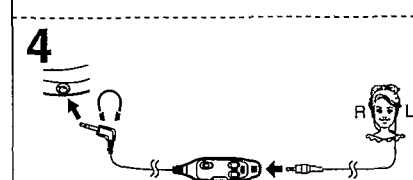
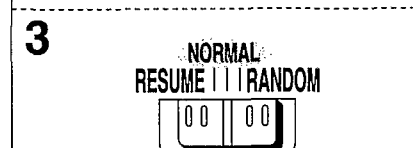
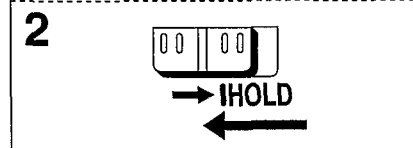
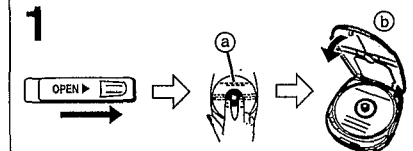
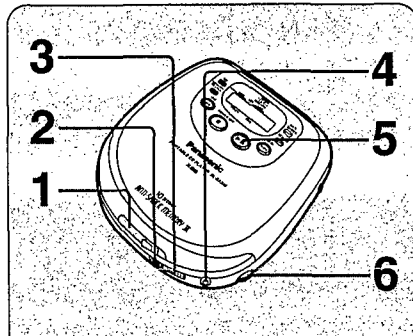

1 Slide OPEN to open the lid, and insert the disc.

- Ⓐ Label must face upward.
Press the area near the center hole of the disc until it clicks into position.
- Ⓑ Close the lid.

2 Release the hold mode.

3 Set play mode selector to NORMAL.

4 Connect the wired remote control and the stereo earphones to the jack.

(Plug in firmly.)

5 Press ► II.

- Play now starts.
- Ⓒ Track number in play
- Ⓓ Elapsed playing time of each track
- Play stops automatically when all the tracks have been played.

6 Adjust the volume level.

(If the unit has been connected to the car audio system, adjust the volume level between 4 and 6 on the unit, then adjust the volume level on the system.)

For your reference:

"no disc" indication
This indication appears for about 30 seconds if ► II is pressed when no disc is loaded in the unit or if the disc is not completely seated.

"OPEN" indication
This indication appears for about 10 minutes when the cover is opened. (However, the indication does not appear when the unit is powered off.)

Auto power off function

If the unit is left in stop or paused status for approximately 10 minutes, the unit powers itself off automatically in order to prevent the battery from running down.
(If no disc is loaded in the unit, it powers itself off in about 30 seconds.)

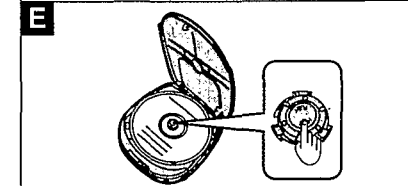
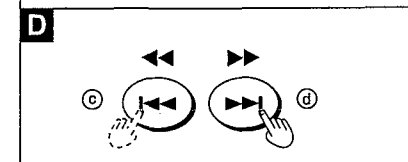
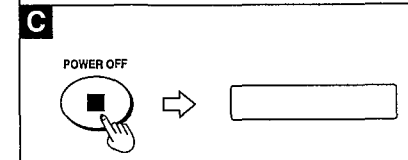
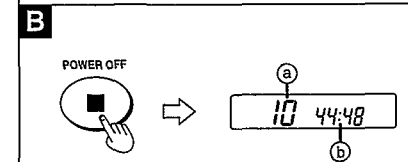
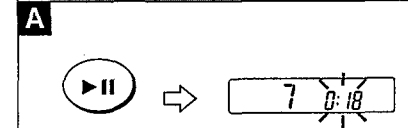
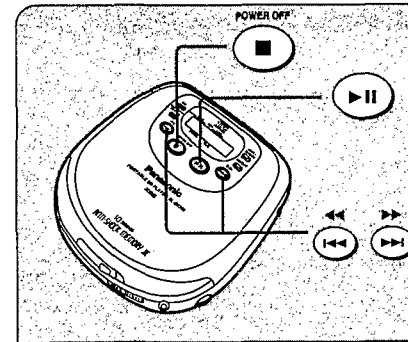

To pause play [A]

Press during play
Press again to resume play

To stop play [Stop mode] [B]

Press during play
Ⓐ Total number of tracks
Ⓑ Total playing time

To turn off the unit [Off mode] [C]

Press during stop mode

Skip forward/backward (skip function) [D]

Press during play
Ⓒ Backward direction
Ⓓ Forward direction

Rapid forward/backward (search function) [E]

Press and hold during play.

Ⓒ Backward direction
Ⓓ Forward direction

• During program play (see page 8), these buttons are used to skip forward or back through the programmed sequence of tracks.

• During random play (see page 8), the skip buttons cannot be used to skip back to tracks that were played previously in the random sequence.

• During program play (see page 8), random play (see page 8) or 1 track repeat play (see page 9), search operation is limited to the current track only.

Removing discs [E]

After the disc has stopped rotating, press the PUSH button to release the disc. (To protect the disc, never open the cover while it is playing.)

Note

Never insert foreign objects into the unit body.

Other Play Methods

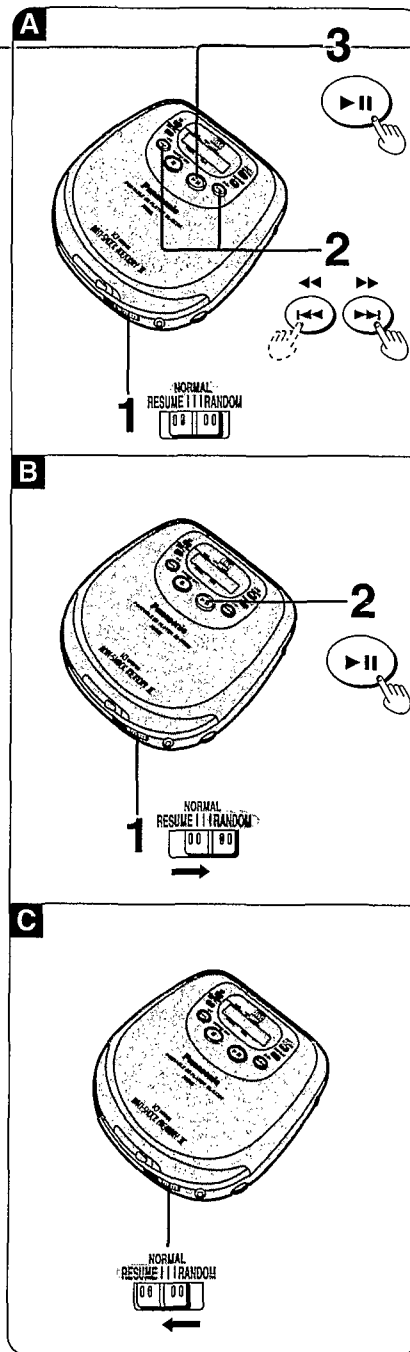

Skip play

The disc plays from the specific track through to the end, then play stops automatically.

Preparation: Put unit in stop mode. (See page 7.)

Follow steps 1-3.

In step 2, select the desired track.

Random play

Follow steps 1-2.

To cancel the random mode

Set play mode selector to NORMAL.

For your reference:

- It is also possible to press the ►► button while the unit is in stop status to change the first track to be played. (All tracks are played eventually, regardless of which is played first.)
- Program play is not possible in the random mode.

Resume play

This function allows you to listen from the beginning of the track where play stopped because the unit was powered off (or switched to stop status). It is useful when listening to CDs in the car, etc.

To cancel the resume mode

Set play mode selector to NORMAL.

For your reference:

- If the RESUME, NORMAL, RANDOM (play mode) selector is put in the RESUME position, the all-repeat function will be activated automatically as soon as the unit is powered on.
- If power is cut off near the end of a track (power off status), playback may resume from the beginning of the next track in some cases.
- If the unit is powered off while a disc was playing and then a new disc is inserted, play will begin from the middle of the new disc because the unit remembers the position where play stopped on the previous disc.

Program play

Up to 24 tracks can be entered in the programmed sequence.

Preparation: Put unit in stop mode. (See page 7.)

Follow steps 1-5.

In step 2, select the desired track.

In step 3, register in sequence.

(The indication "M" and the programmed sequence appear on the display panel.)

■ To program the same track in the sequence more than once

After step 3, press MEMORY/RECALL the desired number of times.

■ If "f" is displayed

No more tracks can be added to the sequence.

■ To confirm the contents of the program

Press MEMORY/RECALL while the disc is playing. (The number of the programmed tracks appear on the display panel in sequence.)

■ To delete the entire programmed sequence

Press , POWER OFF.

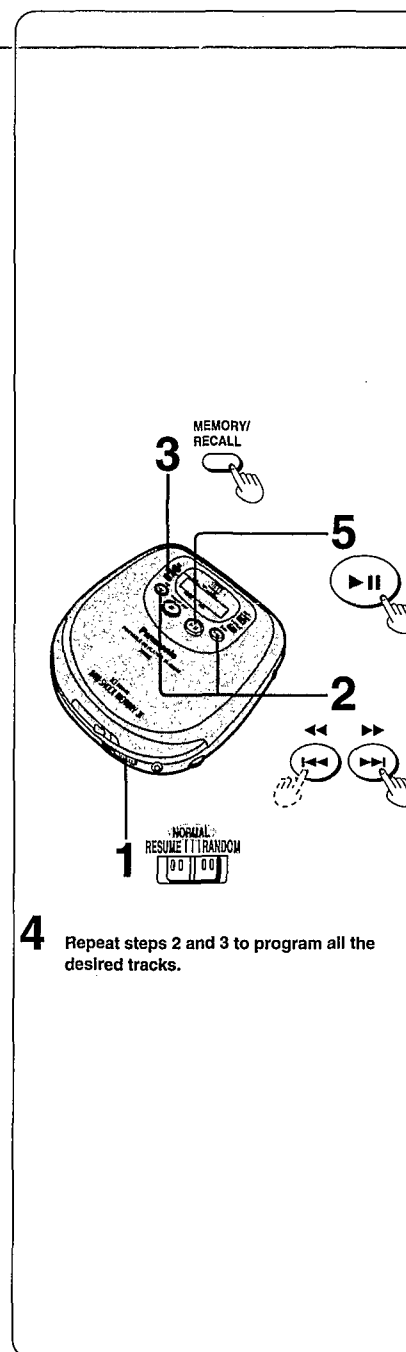

Repeat steps 2 and 3 to program all the desired tracks.

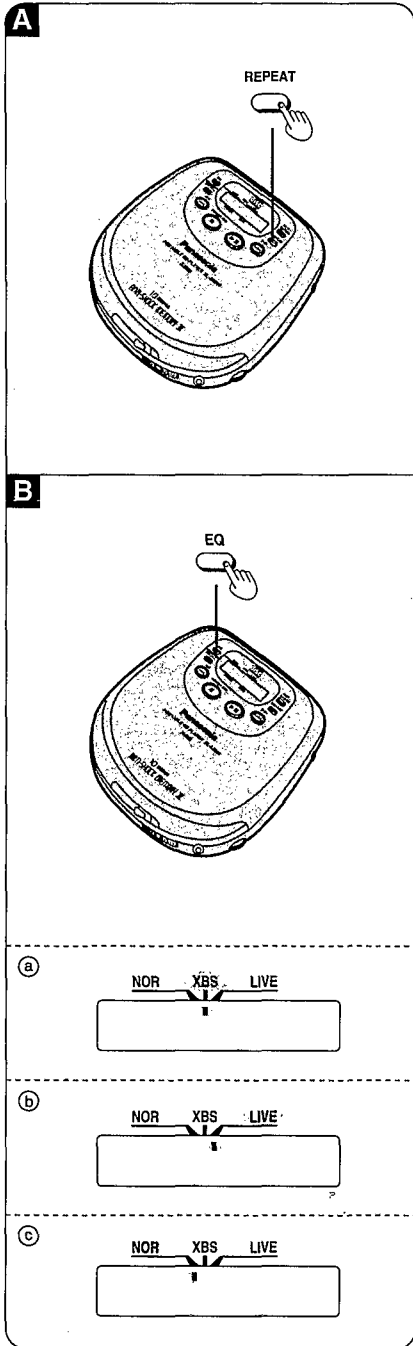

Repeat function

Press REPEAT while disc is playing or when unit is in stop status.

The setting is switched in the sequence indicated below each time REPEAT is pressed.

- 1-track repeat (1) ←
- One track is repeated.
- ↓
- All-track repeat (ALL)
- All the tracks on the disc are repeated.
- ↓
- Cancel

For your reference:
If REPEAT is pressed during program play, only the tracks in the programmed sequence are repeated. (The indication "ALL" is not displayed.)

Changing the sound quality

Press EQ while disc is playing or when unit is in stop status.

The setting is switched in the sequence indicated below each time EQ is pressed.
NOR → XBS → LIVE

- Ⓐ XBS:
Select this setting to boost the low-range response.
- Ⓑ LIVE:
Select this setting to reproduce the sound as it would be heard in a concert hall.
- Ⓒ NOR:
Select this setting to turn off the XBS, LIVE function. Normal sound is heard.

Using the Unit with Optical Accessories

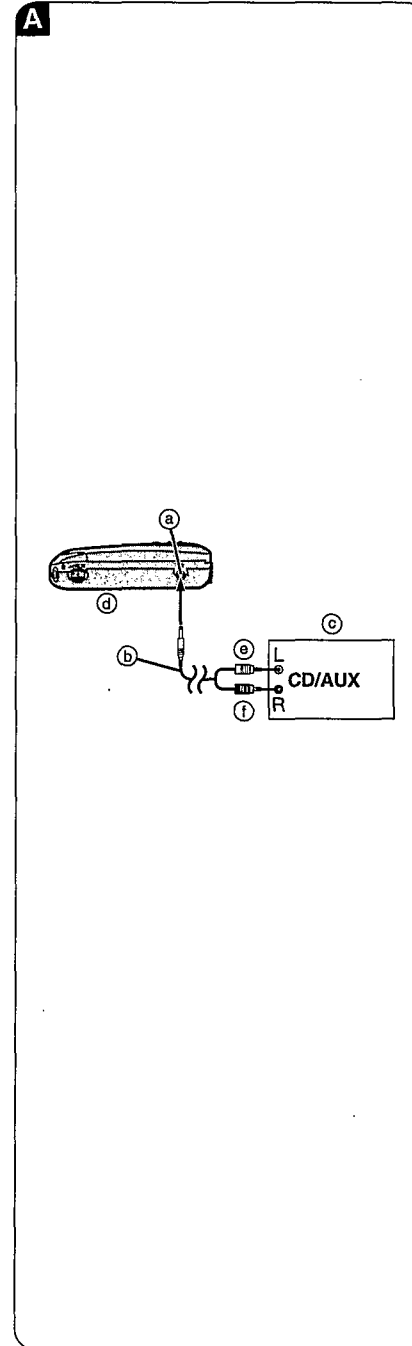

Using the unit with an audio system

Using a stereo connection cable (not included), you can listen to CDs on your audio system.

- Connect the cable to the amplifier after turning off its power.
- Do not connect the cable to the PHONO jacks on the amplifier.
- Obtain the optional connecting cable if the amplifier comes with mini-phone jacks.
- Adjust the volume level on the amplifier.
- Ⓐ OUT jack
- Ⓑ Stereo connection cable (not included)
- Ⓒ Amplifier
- Ⓓ Side panel of the unit
- Ⓔ (White)
- Ⓕ (Red)

Notes

- Sound quality changes when XBS or LIVE is selected, but volume is reduced by approximately fifty percent.
- When using active speakers or other speakers, ensure that they have an input impedance of 1 kΩ or less.

Using the unit with a car audio system stereo

- Items to be purchased**
- For connection to the car audio system:**
- Car stereo cassette adaptor (SH-CDM10A)

Connect the car stereo cassette adaptor to the unit's headphones jack. (When doing this, keep the unit's VOLUME control at a setting between 4 and 6.)

- For securing the unit and connecting the power supply:**
- Car adaptor (SH-CDC9)
 - Car mounting kit (SH-CDF20)

Note

It may not be possible to use the unit with some types of car stereos owing to restrictions imposed by the construction of the car stereo cassette adaptor.

For further details, refer to the instructions of the part concerned.

Concerning Compact Disc

A



Only compact discs bearing this mark can be used with this unit. **A**

However, continued use of irregular shape CDs can damage the unit. **B**

How to remove a disc from its case **C**

How to store the disc in its case **D**

ⓐ Label side

How to hold a disc **E**

If the surface is dirty **F**

ⓑ Play surface (shiny surface)

Wipe it with a damp cloth and then wipe dry. Wipe from the center toward the circumference.

If moisture has formed on a disc

When moisture has formed because the disc was brought suddenly into a warm room from a cold environment, wipe it off using a soft dry cloth.

When storing discs

- Avoid locations which are
- Exposed to direct sunlight.
 - Susceptible to high levels of humidity or dust.
 - Directly exposed to heat from a heating appliance.
 - On top of a car dashboard or near the rear window.

Handling precautions

- On the label side (the side with writing)
 - Do not write anything using a pencil, ball-point pen, etc. Do not stick paper or labels.
- On the disc (shiny) side
 - Handle this side carefully to keep it free from fingerprints or scratches. Do not use record cleaners, solvents, etc.
 - Do not attach labels or stickers to CD's.
 - Do not use CDs with exposed adhesive from tape or left over peeled off stickers.
 - Do not use scratch-proof protectors or covers other than those specified for use with this unit.

B



C

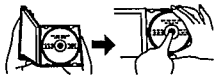

D



E

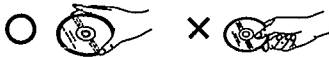

F

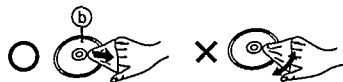

Troubleshooting Guide

First, consult the table below. If the problem persists, contact the dealer from whom you purchased the unit.

Problem	Check this
Cannot close cover.	Is the disc properly secured in place?
Cannot play discs.	<ul style="list-style-type: none"> ● Is the unit in hold status? ● Is the disc properly secured in place? ● Is there condensation on the lens? (Wait for about an hour and then try again.)
Cannot remove disc.	Did you press the PUSH button to release the disc?
Tracks on disc do not play in order, starting with the first track.	Is the RESUME, NORMAL, RANDOM (play mode) selector in the NORMAL position?
Cannot hear music—too noisy.	<ul style="list-style-type: none"> ● Has earphones and the wired remote control plug been inserted as far as it will go? ● Are the plugs dirty? (Wipe away dirt on plug)
TV picture is distorted. Radio reception is noisy.	Are you using the unit body too near a TV or tuner? (If the TV or tuner is connected to a simple indoor antenna, connect it to an outdoor antenna.)

Maintenance

Maintaining the unit

- Wipe the unit with a soft cloth. Remove stubborn dirt using a cloth which has been dipped in water or soapy water and wrung out, and then wipe dry.
- If you intend to use a chemical cleaning cloth, read its directions first.
 - Do not use alcohol or paint thinners.

Maintaining the lens

Open the lid and clean the lens as shown in the figure. Use a cotton swab to gently wipe off any finger-prints. Recommended product: Lens cleaner kit (SZZP1038C)

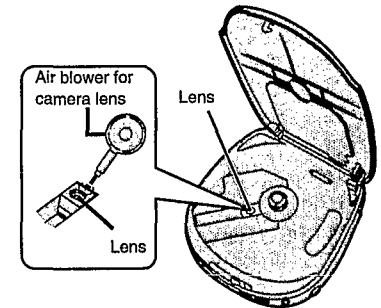

■ Handling Precautions for Traverse Deck

The laser diode in the traverse deck (optical pickup) may break down due to potential difference caused by static electricity of clothes or human body.

So, be careful of electrostatic breakdown during repair of the traverse deck (optical pickup).

● Handling of traverse deck (optical pickup)

1. Do not subject the traverse deck (optical pickup) to static electricity as it is extremely sensitive to electrical shock.
2. The short land between the No. ⑫ (LD GND) and No. ⑬ (LD) pins on the flexible board (FFC) is shorted with a solder build-up to prevent damage to the laser diode. To connect to the PC board, be sure to open by removing the solder build-up, and finish the work quickly.
3. Take care not to apply excessive stress to the flexible board (FFC).
4. Do not turn the variable resistor (laser power adjustment). It has already been adjusted.

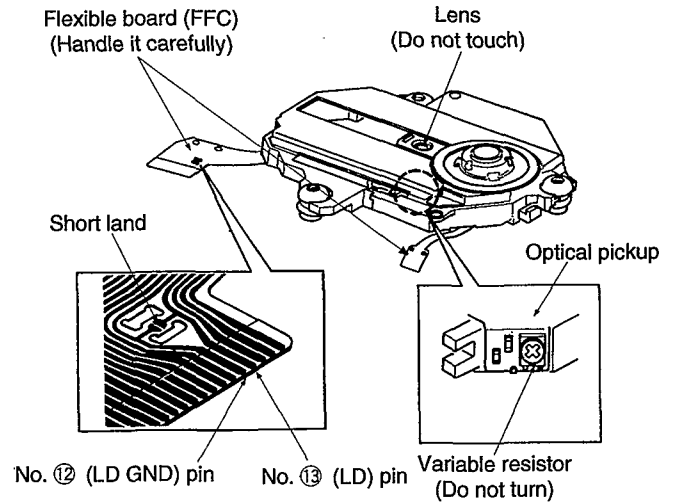

● Grounding for electrostatic breakdown prevention

1. **Human body grounding**
Use the anti-static wrist strap to discharge the static electricity from your body.
2. **Work table grounding**
Put a conductive material (sheet) or steel sheet on the area where the optical pickup is placed, and ground the sheet.

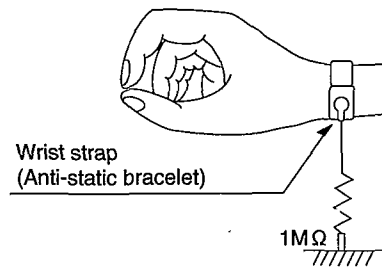

Caution:

The static electricity of your clothes will not be grounded through the wrist strap. So, take care not to let your clothes touch the traverse deck (optical pickup).

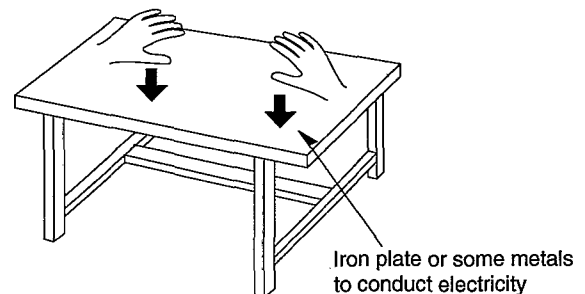

■ Operation Checks and Component Replacement Procedures

- NOTE**
1. This section describes procedures for checking the operation of the major printed circuit boards and replacing the main components.
 2. For reassembly after operation checks or replacement, reverse the respective procedures. Special reassembly procedures are described only when required.
 3. [] indicates parts No.

● Contents

■ Checking Procedures for each P.C.B.	Page.
1. Checking for the main P.C.B.	12~14.
■ Main Component Replacement Procedures	
1. Replacement for the traverse deck.	14.
2. Replacement for the CD cover ass'y and LCD.	14,15.

■ Checking Procedures for each P.C.B.

1. Checking for the main P.C.B.

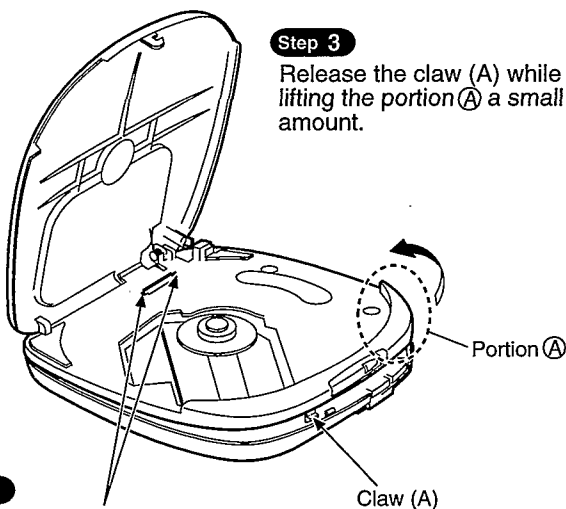
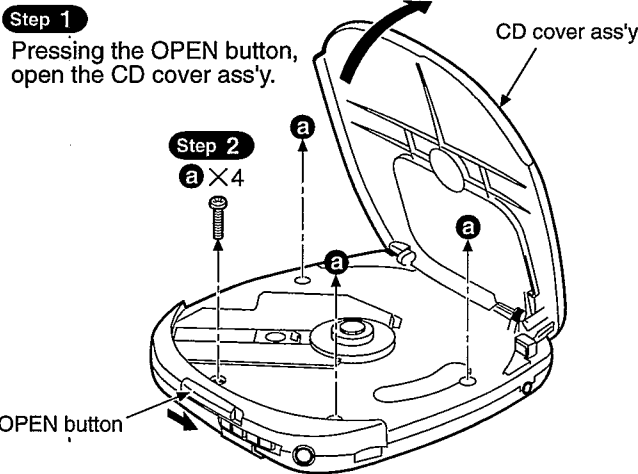

Step 5
Release the 3 claws (C) at the rear of unit.

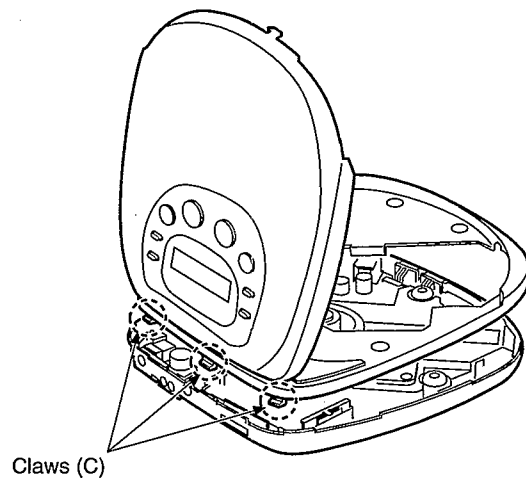

Step 6
Move the intermediate cabinet ass'y in the direction of arrow.

Intermediate cabinet ass'y

Step 7

Sustain the traverse deck with the floating rubber inserted screws and nuts as shown above.

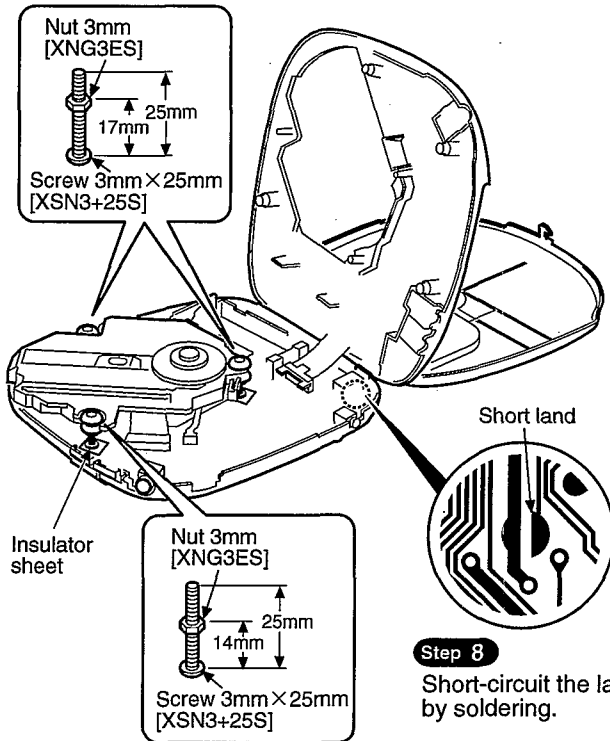

Step 8
Short-circuit the land by soldering.

NOTE

- After checking, unsolder the short land to open circuit.
- The tip of screw must not protrude above the floating rubber.
- To keep insulation, place the insulator sheet (paper etc.) between the P.C.B. and the head of screws.

• Check the main P.C.B. (A side) as shown below.

Step 9

Put the disc (8cm).

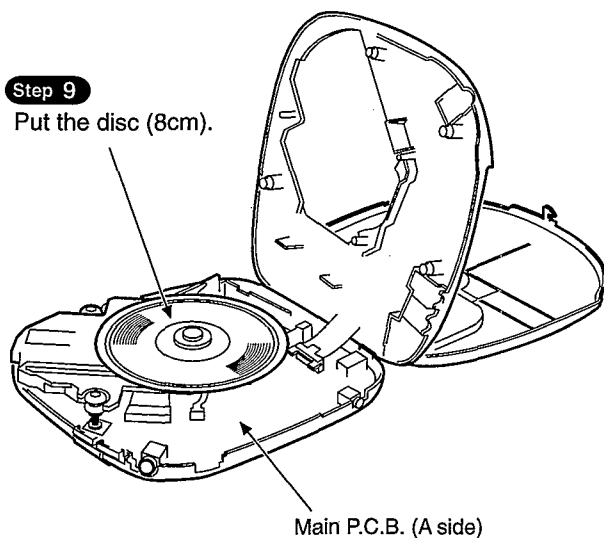

⟨Checking for the main P.C.B. (B side)⟩

Step 3

Remove the traverse deck and main P.C.B..

Step 2

Remove the 2 switch knobs.

Step 1

Short-circuit the land by soldering.

Step 4

Align the floating rubber with the boss.

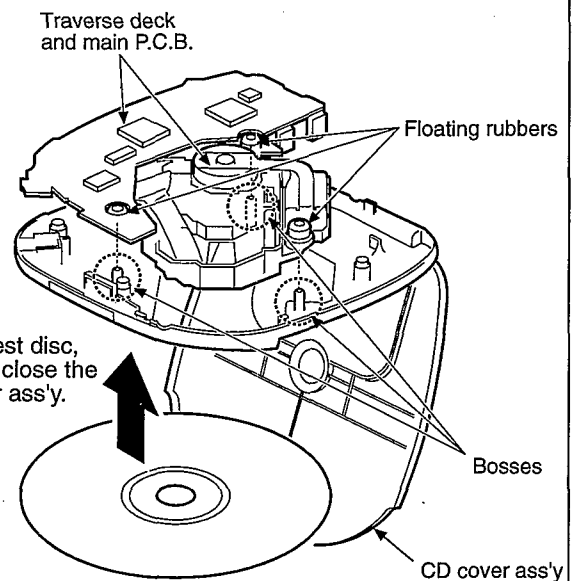

Step 5

Put the test disc, and then close the CD cover ass'y.

• Check the main P.C.B. (B side) as shown below.

Main P.C.B. (B side)

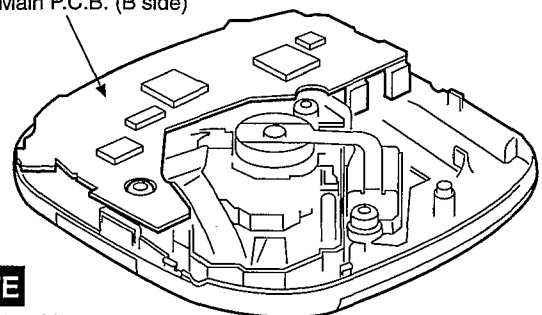

NOTE

After checking, unsolder the short land to open circuit.

Notice for installation of switch knobs

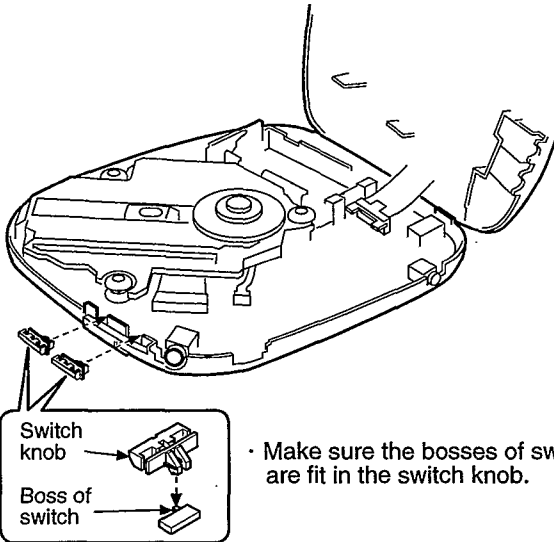

• Make sure the bosses of switch are fit in the switch knob.

Main Component Replacement Procedures

1. Replacement for the traverse deck

• Follow the **Step 1** ~ **Step 6** of the item 1 in checking procedure for each P.C.B. on page 12.

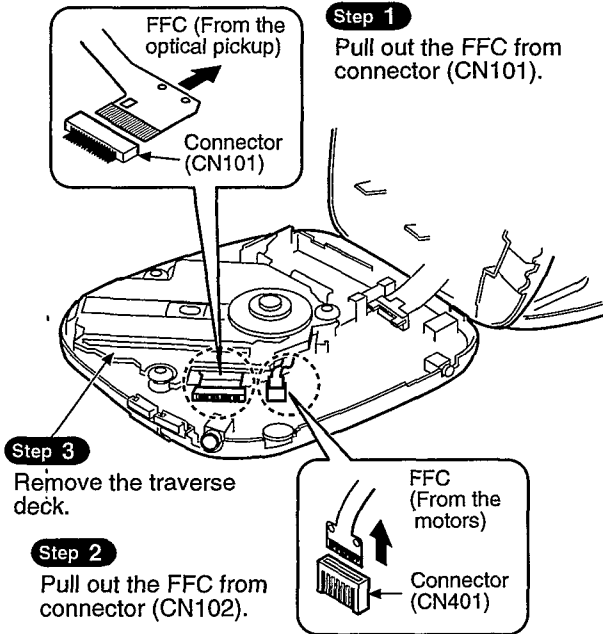

NOTE

Solder the point between pin ⑫ (LD GND) and pin ⑬ (LD) of FFC.
 (Refer to "Handling Precautions for Traverse Deck" on page 11.)

2. Replacement for the CD cover ass'y and LCD

• Follow the **Step 1** ~ **Step 6** of the item 1 in checking procedure for each P.C.B. on page 12.

Step 1

Remove the FFC from connector (CN301).

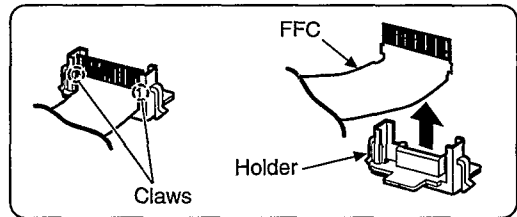
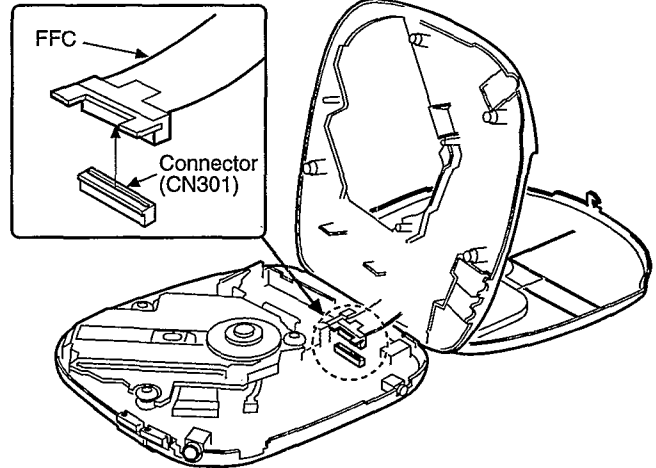

Step 2

Release the 2 claws, and then remove the FFC.

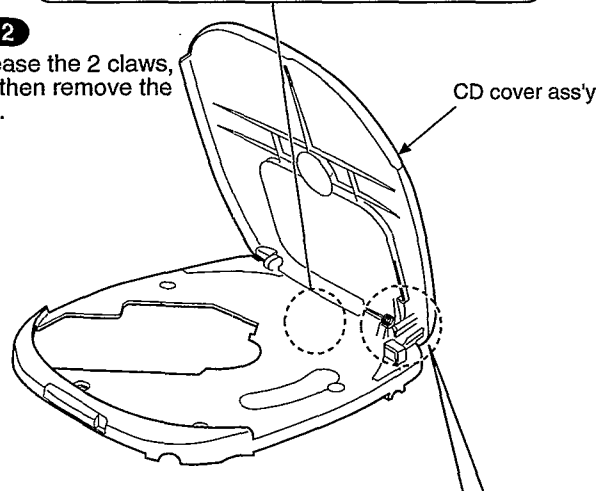

Minus screwdriver

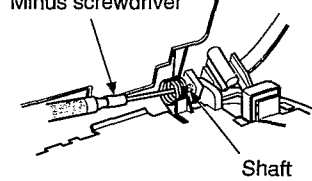

Step 3

Extrude the shaft with thin tip of minus screwdriver.

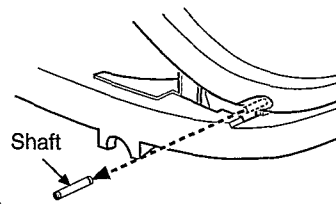

Step 4

Draw the projected shaft.

Step 4

Release the CD cover ass'y from the rib of intermediate cabinet.

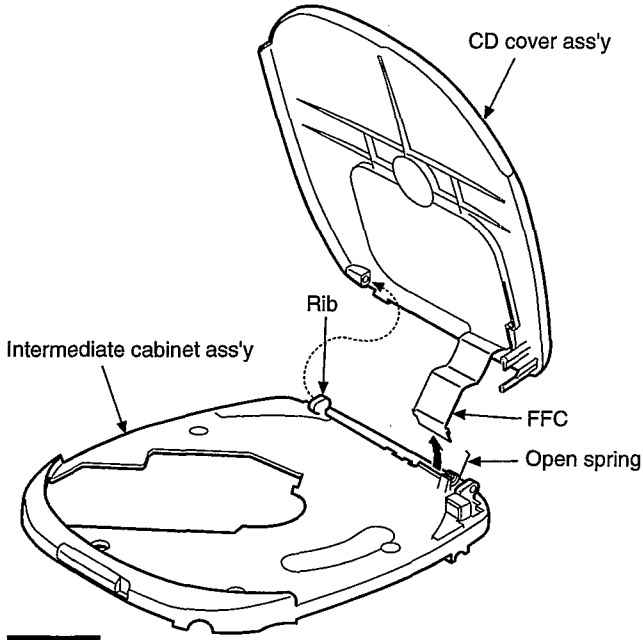

NOTE

1. Take care not to damage the FFC.
2. Take care not lose the open spring.

Step 5

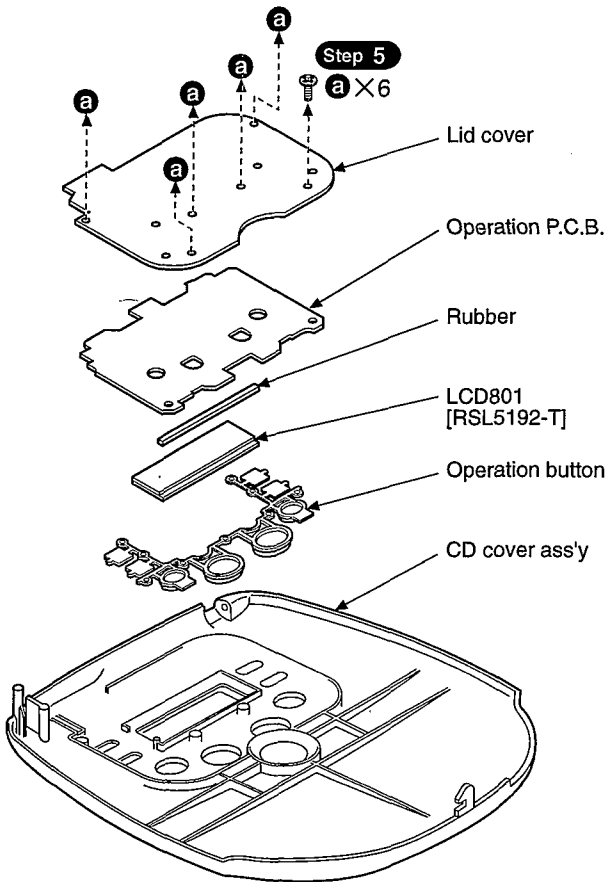

NOTE

Be careful not to be applied the dust or smudge on the surface of rubber.

Installation of CD cover ass'y

Step 1

Align the end of spring with the slot, and then locate the spring on the intermediate cabinet ass'y.

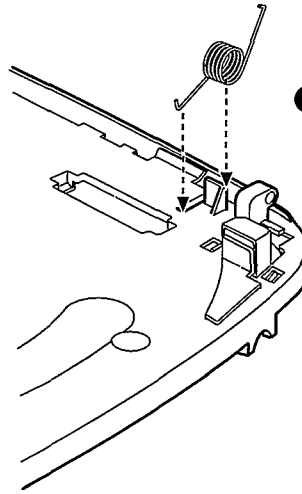

Step 2

Install the CD cover ass'y to the intermediate cabinet ass'y in order items ①, ②, ③, ④.

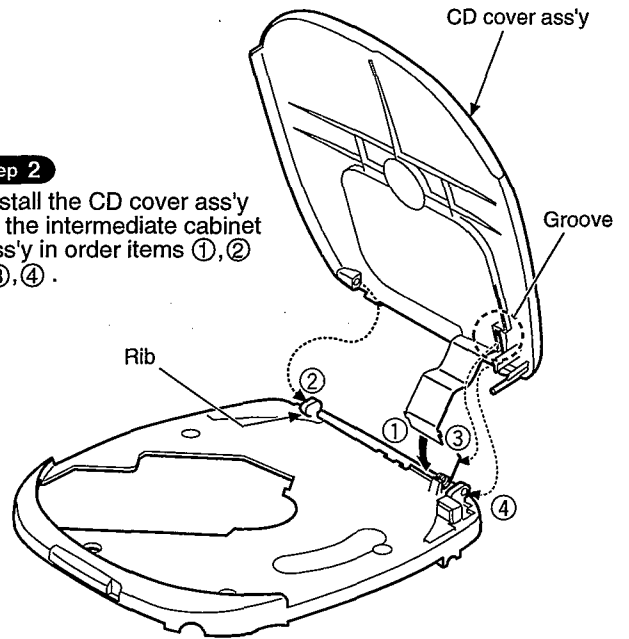

Step 3

Close the CD cover ass'y.

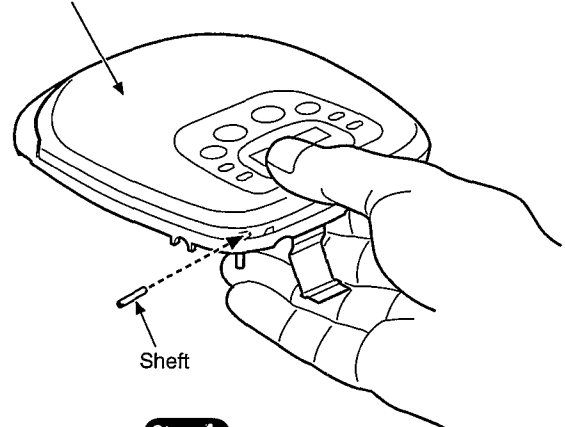

Step 4

Hold the CD cover ass'y with finger, and then put the shaft into CD cover ass'y.

■ Checking the Operation Problems on the Traverse Deck (Optical Pickup)

Make sure to follow the procedures below to check the operation problems of the traverse deck (optical pickup) before replacing it. Replace the traverse deck only after the problem is identified.

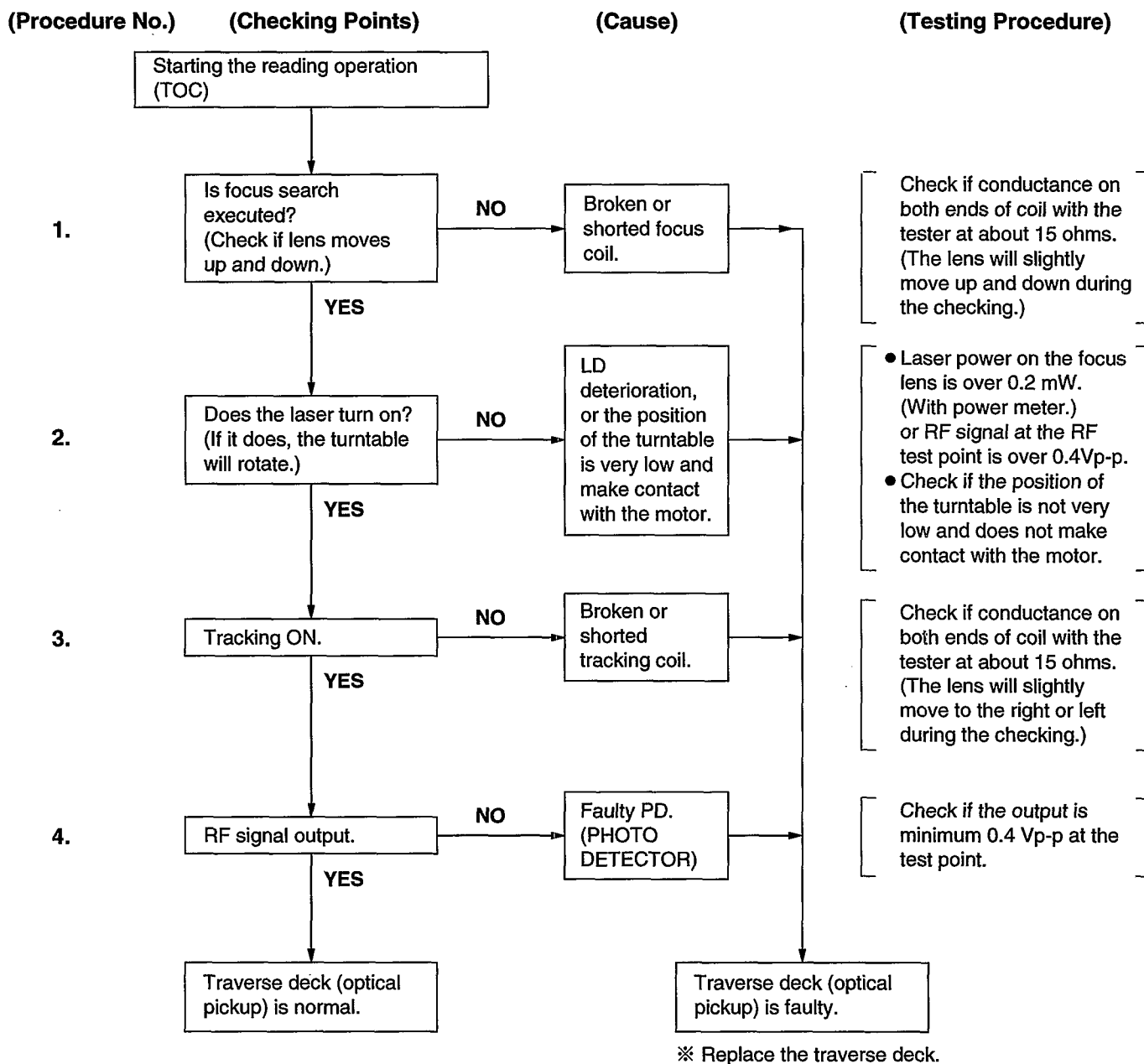

- Check electrical circuit. (IC, etc.)
- Check for flaws on disc or if it is warped or not centered.

● Check the operations described below on the traverse deck after replacing it.

* Checking Skip Search

1. Play an ordinary musical program disc.
2. Press the skip button to check for normal skip search operation (in both the forward and reverse directions).

* Checking Manual Search

1. Play an ordinary musical program disc.
2. Press the manual search button to check for smooth manual search operations at either low or high speed (in both the forward and reverse directions).

* Checking Playability

1. Play the 0.7 mm black dot and the 0.7 mm wedge on the playability test disc (SZZP1054C) and verify that no sound skip or noise occurs.
2. Play the middle tracks of the uneven test disc (SZZP1056C) and verify that no sound skip or noise occurs.

■ Automatic Adjustment Results Display Function (Self-check Function)

On this unit (SL-SX300), each automatic adjustment result are displayed on the LCD. This function is convenient to check or identify which automatic adjustment circuit is incorrect. The followings are the contents of the automatic adjustment result displays (self-check function).

● How to display automatic adjustment results

1. Load the test disc (SZZP1054C).
2. Press the ◀◀ (SKIP/SEARCH) and ▶▶ (SKIP/SEARCH) Buttons simultaneously and hold them, and additionally press the ▶/|| (PLAY/PAUSE) Button.
3. Press the ■ (STOP/POWER OFF) Button once.
4. An automatic adjustment result is displayed on the LCD.

● Display of automatic adjustment results (self-check function)

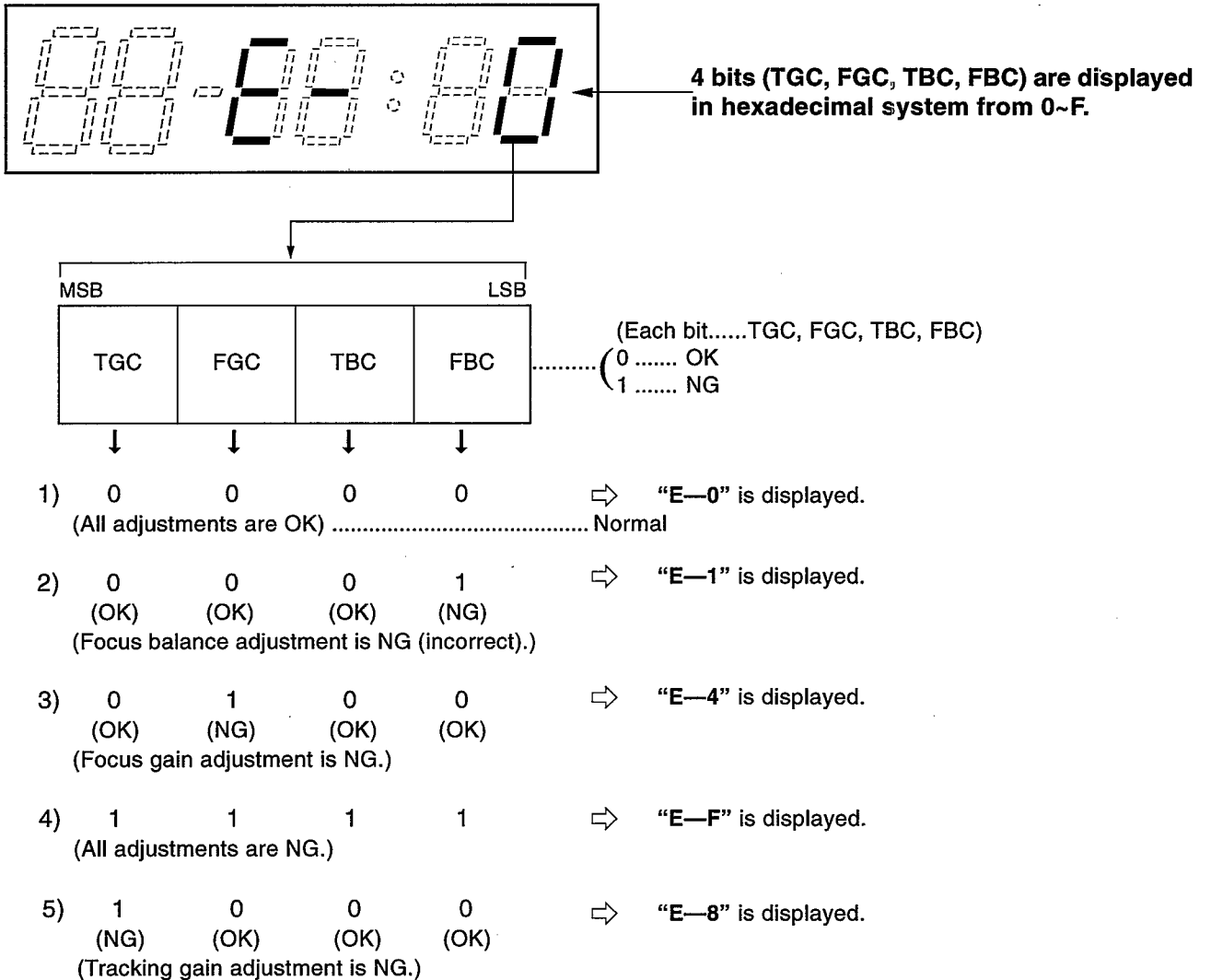

Note: If any other disc than the test disc (SZZP1054C) is used, an "E—8" may be displayed.

<Example> **Follow the below steps when "E-1" is displayed.**

(Cause: Focus balance (FBC) is set beyond the limit.)

- Check if
 - (1) the waveform or voltage of the focus servo circuit is correct.
 - (2) the optical pickup returns to the normal state by exchanging the traverse deck.

Follow the below steps when "E-4" is displayed.

(Cause: Focus gain (FGC) is set beyond the limit.)

- Check if
 - (1) the waveform or voltage of the focus servo circuit is correct.
 - (2) the focus coil of the optical pickup is correct (around 15 ohms).
 - (3) the optical pickup returns to the normal state by exchanging the traverse deck.

Follow the below steps when "E-F" is displayed.

(Cause : All adjustments (TGC, FGC, TBC, FBC) are set beyond the limit.)

- Check if
 - (1) the optical pickup returns to the normal state by exchanging the traverse deck.
 - (2) the waveform or voltage of the servo IC's are correct.

Note:

It is not always necessary to exchange the traverse deck when an error message is displayed. Be sure to check if the circuit is defective or not before exchanging the traverse deck.

Note:

If any other disc than the test disc (SZZP1054C) is used, an error message may be displayed. This is not a malfunction.

■ Measurements and Adjustments

Warning: This product uses a laser diode. Refer to caution statements on page 2.

ACHTUNG: ● Die lasereinheit nicht zerlegen.

- Die lasereinheit darf nur gegen eine vom hersteller spezifizierte einheit ausgetauscht werden.

● Measuring instruments and special tools

● **Test discs**

1. Playability test disc (SZZP1054C)
2. Uneven test disc (SZZP1056C)

- Musical program disc (ordinary)

- DC voltmeter
- Lead wire (for test points)

● Test short land

Short-circuit the lands of the laser ON/OFF switch (S201) by soldering them. It turns "ON" position. (Refer to below **Fig. 1** or printed circuit board and wiring connection diagram for short land location on page 27.)

Note: Remove the solders from the lands after adjustment.

- Adjustment point

Notes: 1. Please refer to the printed circuit board and wiring connection diagram for test point locations on page 27.

2. Take care to connect CN101 and CN102, as shown in **Fig. 1**.

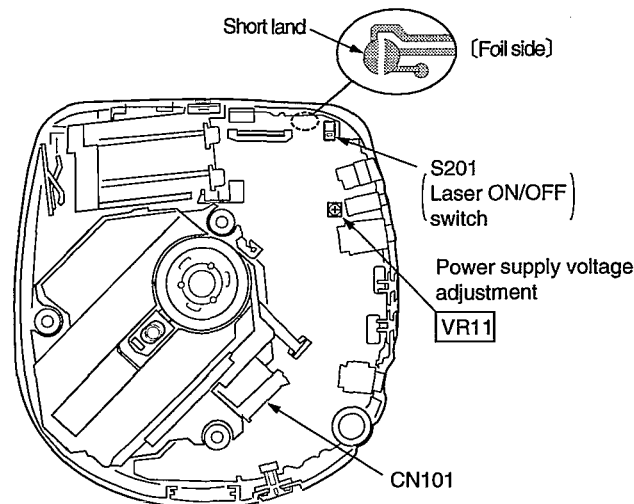

Fig. 1

(1) POWER SUPPLY VOLTAGE ADJUSTMENT

1. Connect the DC voltmeter to **TP103** (VCC) (+) and **TP104** (GND) on the P.C.B.
2. Connect the AC adaptor cord to the DC (IN) port and move the PLAY switch to the ON position.
(Use a new dry cell battery or a rechargeable battery that is full charged.)
3. Insert the test disc, and switch the player power ON.
4. Adjust **VR11** on the P.C.B. at 2.75 ± 0.02 V, as shown in Fig. 1.

(2) CHECK OF PLAY OPERATION*** Checking Skip Search**

1. Play an ordinary musical program disc.
2. Press the skip button to check for normal skip search operation (in both the forward and backward directions).

*** Checking Manual Search**

1. Play an ordinary musical program disc.
2. Press the manual search button to check for smooth manual search operations at either low or high speed (in both the forward and backward directions).

*** Checking Playability**

1. Play the 0.7 mm black dot and the 0.7 mm wedge on the playability test disc (SZZP1054C) and verify that no sound skip or noise occurs.
2. Play the middle tracks of the uneven test disc (SZZP1056C) and verify that no sound skip or noise occurs.

• Automatic adjustment

On our conventional type portable CD player, there were mounted 6 semi-fixed controls for each adjustment. Since the SL-SX300 servo circuit is equipped with an automatic adjusting circuit, these controls are removed from SL-SX300.

On conventional portable CD player
Use for Old Servo IC (AN8373, AN8374)

On SL-SX300
Use for New Servo IC (AN8839NSBE1, MN662780RPS2)

- | | | | |
|---|--------------------------|---|-----------------------------|
| 1. Tracking Offset Adjustment VR (TOC) | <input type="checkbox"/> | ➔ | Non Adjustment |
| 2. Focus Offset Adjustment VR (FOC) | <input type="checkbox"/> | | |
| 3. Tracking Gain Adjustment VR (TGC) | <input type="checkbox"/> | | |
| 4. Focus Gain Adjustment VR (FGC) | <input type="checkbox"/> | ➔ | Automatic Adjusting Circuit |
| 5. Tracking Balance Adjustment VR (TBC) | <input type="checkbox"/> | | |
| 6. Focus Balance Adjustment VR (FBC) | <input type="checkbox"/> | | |

Total 6 Adjustment VRs

➔ No Adjustment VR

Although all discs are manufactured according to the same specifications, their characteristics are not always precisely the same because they are produced by different manufacturers in various lots, or have different warp etc. SL-SX300 automatically controls the servo circuit to obtain optimum performance according to any disc's characteristics. Therefore, no malfunction occurs because of mis-adjustment.

Outline of 10-Second Sound Keeper Technique Used for Prevention of Sound from Skipping

1. Conventional Shockproofing Technique

Input information read out of the CD at double speed is demodulated, stored in the memory, and while sound-marking signal is supplied at normal speed from the memory to the D/A converter, the residual data is accumulated in the memory.

If reaccess to the break point is accomplished before the memory becomes empty, apparent playback sound is entirely kept free from breaking even when information pauses due to vibration, etc. It was necessary to use the 4M bit memory for securing the accumulation time of about 10 seconds.

2. Compression-shockproofing [Outline]

Fig. 1 is a block diagram showing the compression-shockproofing mechanism, the difference of which from the conventional mechanism is as follows: Input information read out at double speed undergoes data compression (16 bits → 4 bits) by the encoder in the ADPCM (Adaptive Difference PCM) and stored in the external memory; the stored memory information undergoes data elongation (4 bits → 16 bits) by the decoder in the ADPCM and supplied at normal speed to the D/A converter.

The data compression technique has conducted to reduction of required memory capacity from 4M bits to 1M bit for securing the accumulation time equivalent to the conventional.

All-inclusive Block Diagram

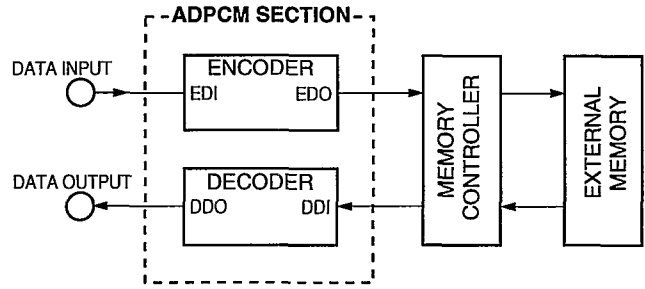
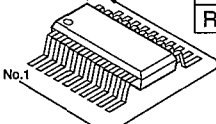
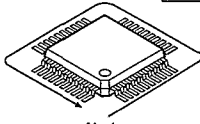
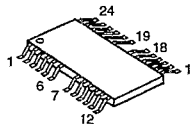
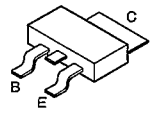
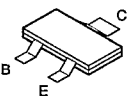
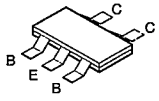
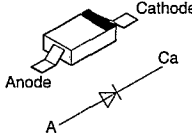
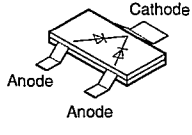
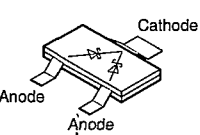
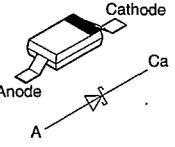

Fig. 1

Type Illustration of IC's, Transistors and Diodes

 <table border="1" data-bbox="279 1075 518 1187"> <tr><td>NJU7082BVTE1</td><td>8PIN</td></tr> <tr><td>AN8839NSBE1</td><td>28PIN</td></tr> <tr><td>BH6508FSE2</td><td>32PIN</td></tr> <tr><td>RS10002E2</td><td>40PIN</td></tr> </table>	NJU7082BVTE1	8PIN	AN8839NSBE1	28PIN	BH6508FSE2	32PIN	RS10002E2	40PIN	 <table border="1" data-bbox="726 1075 973 1131"> <tr><td>SC440307CFU</td><td>64PIN</td></tr> <tr><td>MN662780RPS2</td><td>80PIN</td></tr> </table>	SC440307CFU	64PIN	MN662780RPS2	80PIN	<p>MNV4400-T8T</p> 	<p>2SB1182TLPQR</p> 
NJU7082BVTE1	8PIN														
AN8839NSBE1	28PIN														
BH6508FSE2	32PIN														
RS10002E2	40PIN														
SC440307CFU	64PIN														
MN662780RPS2	80PIN														
 <p>2SB1218ATX 2SB709ATX 2SD1328TX 2SD1328STTX</p> <p>2SD1819ATX DTA114YUA106 UN5115TX UN5213TX</p>	<p>XN1210TX XN1215TX</p> 	<p>MA111TX</p> 	<p>MA142WKTX</p> 												
<p>MA741WKTX</p> 	<p>MA2ZD0200L</p> 														

■ Schematic Diagram (See parts list on pages 39, 40.)

(This schematic diagram may be modified at any time with the development of new technology.)

Notes:

- **S201** : Laser ON/OFF switch in "OFF" position.
(It turns "ON" with disc holder closed.)
 - **S202** : Rest detector in "OFF" position.
(It turns "ON" when optical pickup comes to innermost periphery.)
 - **S301** : Play mode selector (MODE) in "RANDAM" position.
[NORMAL↔RANDOM↔RESUME]
 - **S302** : Hold lock (HOLD) switch in "ON" position.
 - **S801** : Play/pause (▶▶||) switch.
 - **S802** : Stop/power off (■, POWER OFF) switch.
 - **S803** : Skip/search (▶▶|/▶▶) switch.
 - **S804** : Skip/search (|◀◀/◀◀) switch.
 - **S805** : Repeat (REPEAT) switch.
 - **S806** : Memory/recall (MEMORY/RECALL) switch.
 - **S807** : XBS/VMSS/OFF selector (XBS/VMSS/OFF) switch in "OFF" position.
 - **S808** : Anti-shock (EXTRA ANTI-SHOCK) switch in "OFF" position.
 - **S809** : Battery check (BATT CHECK) switch.
 - **VR701** : Headphones volume (VOLUME) switch.
- The voltage value and waveforms are the reference voltage of this measured by DC electronic voltmeter (high impedance) and oscilloscope on the basis of GND terminal (DC IN Jack). Accordingly, there may arise some errors in the voltage values and waveforms depending upon the internal impedance of the tester or measuring unit.

● Measurement conditions:

- * ()...Anti-shock: ON
- * Set the hold lock switch to ON.
- * The parenthesized is the voltage for test disc (1 kHz, L + R, 0 dB) in play mode, and the other, for no disc in stop mode.
- * AC adaptor is used for power supply.

-  : Positive voltage lines.

-  : Audio signal lines.

● Important safety notice:

Components identified by Δ mark have special characteristics important for safety. Furthermore, special parts which have purposes of fire-retardant (resistors), high-quality sound (capacitors), low-noise (resistors), etc. are used. When replacing any of components, be sure to use only manufacture's specified parts shown in the parts list.

Caution!

IC and LSI are sensitive to static electricity.

Secondary trouble can be prevented by taking care during repair.

- Cover the parts boxes made of plastics with aluminum foil.
- Ground the soldering iron.
- Put a conductive mat on the work table.
- Do not touch the pins of IC or LSI with fingers directly.

B MAIN CIRCUIT (P.C.Board: on pages 27, 28)

A OPERATION CIRCUIT
(P.C.Board: on page 27)

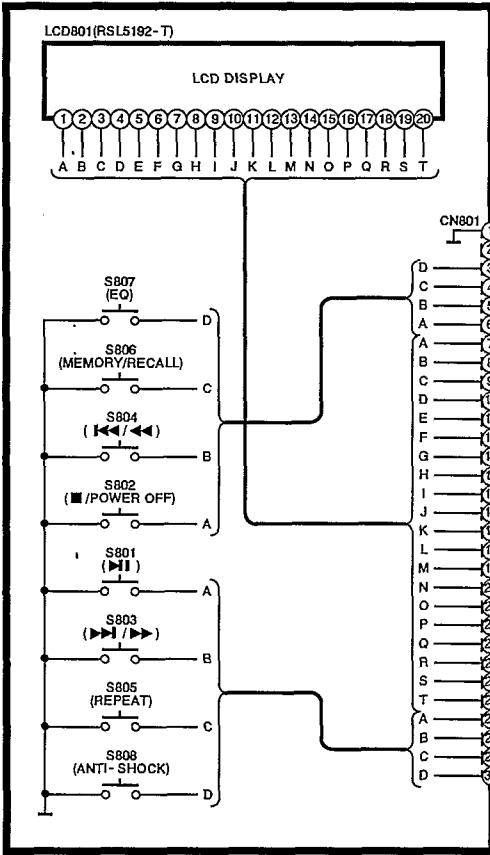

Δ OPTICAL PICKUP

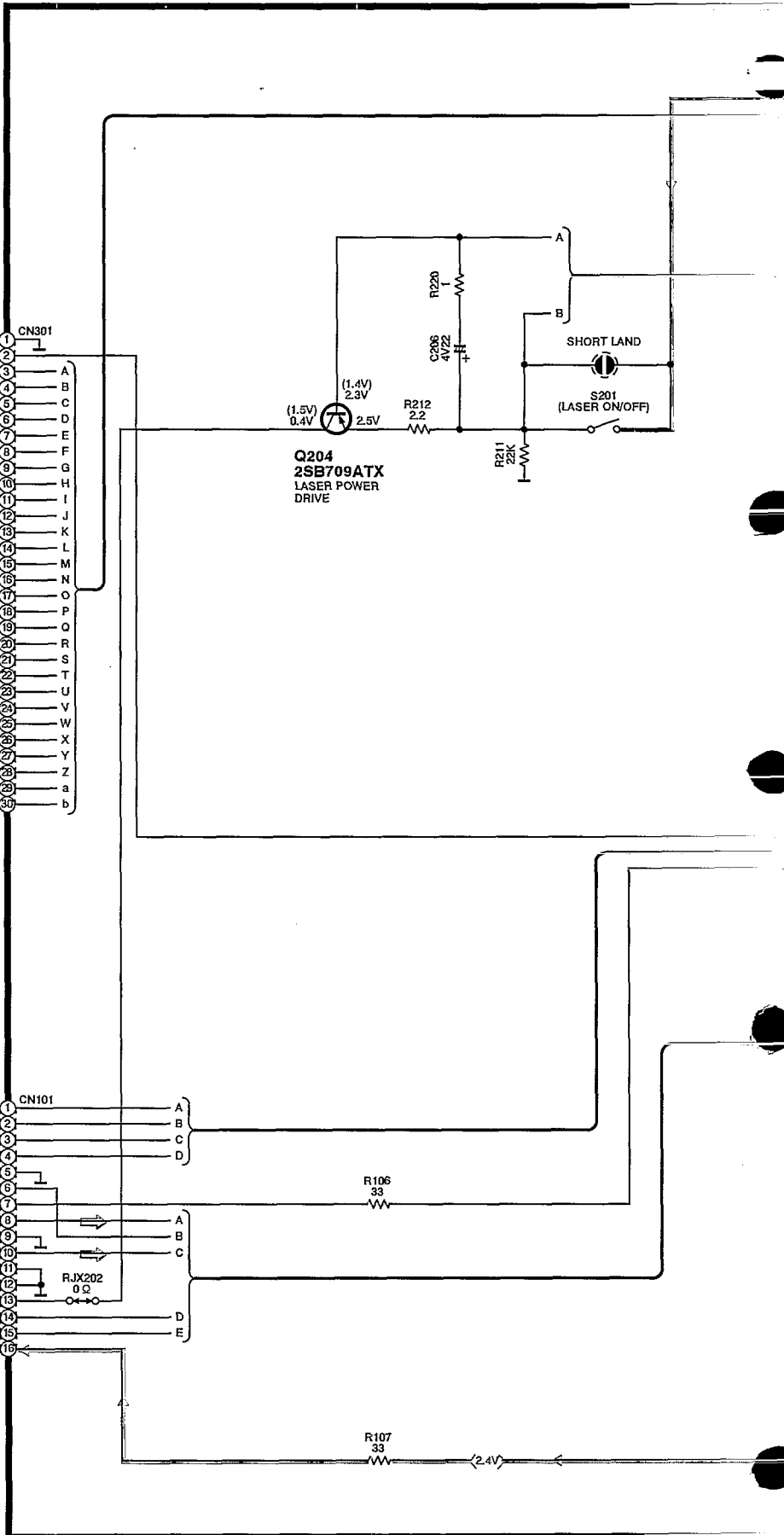
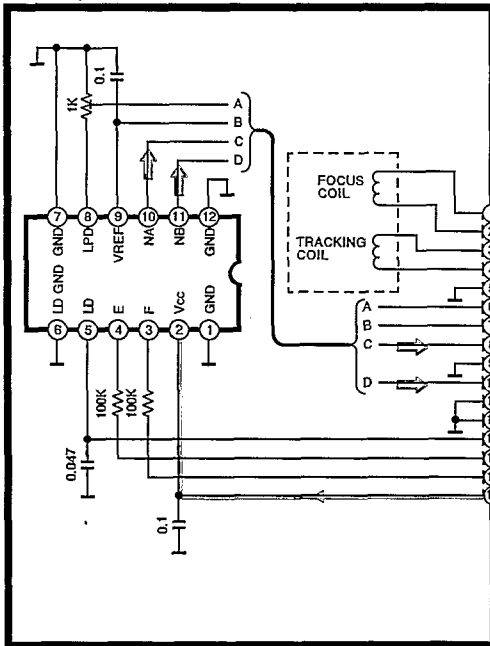

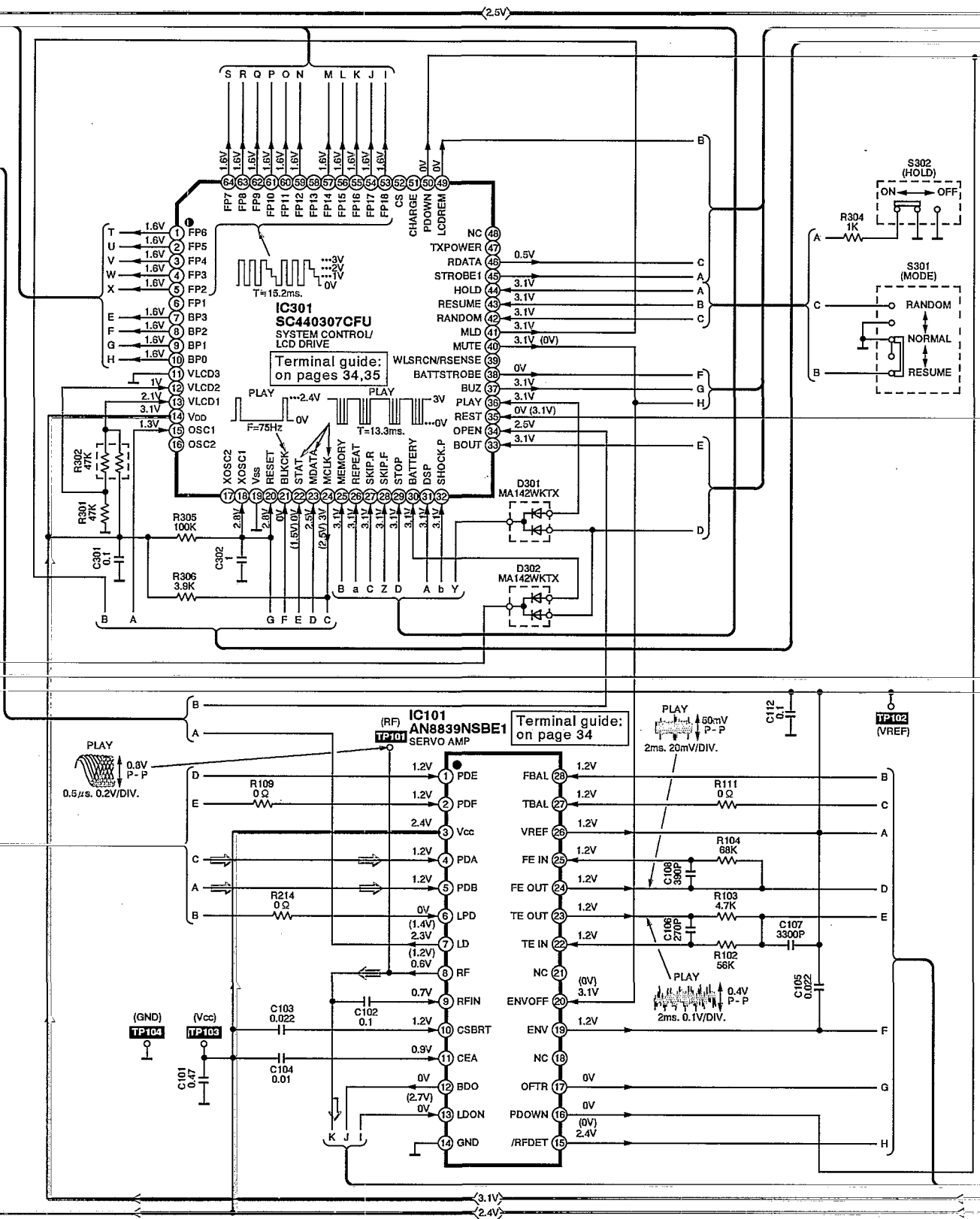

B MAIN CIRCUIT (P.C.Board: on pages 27,28)

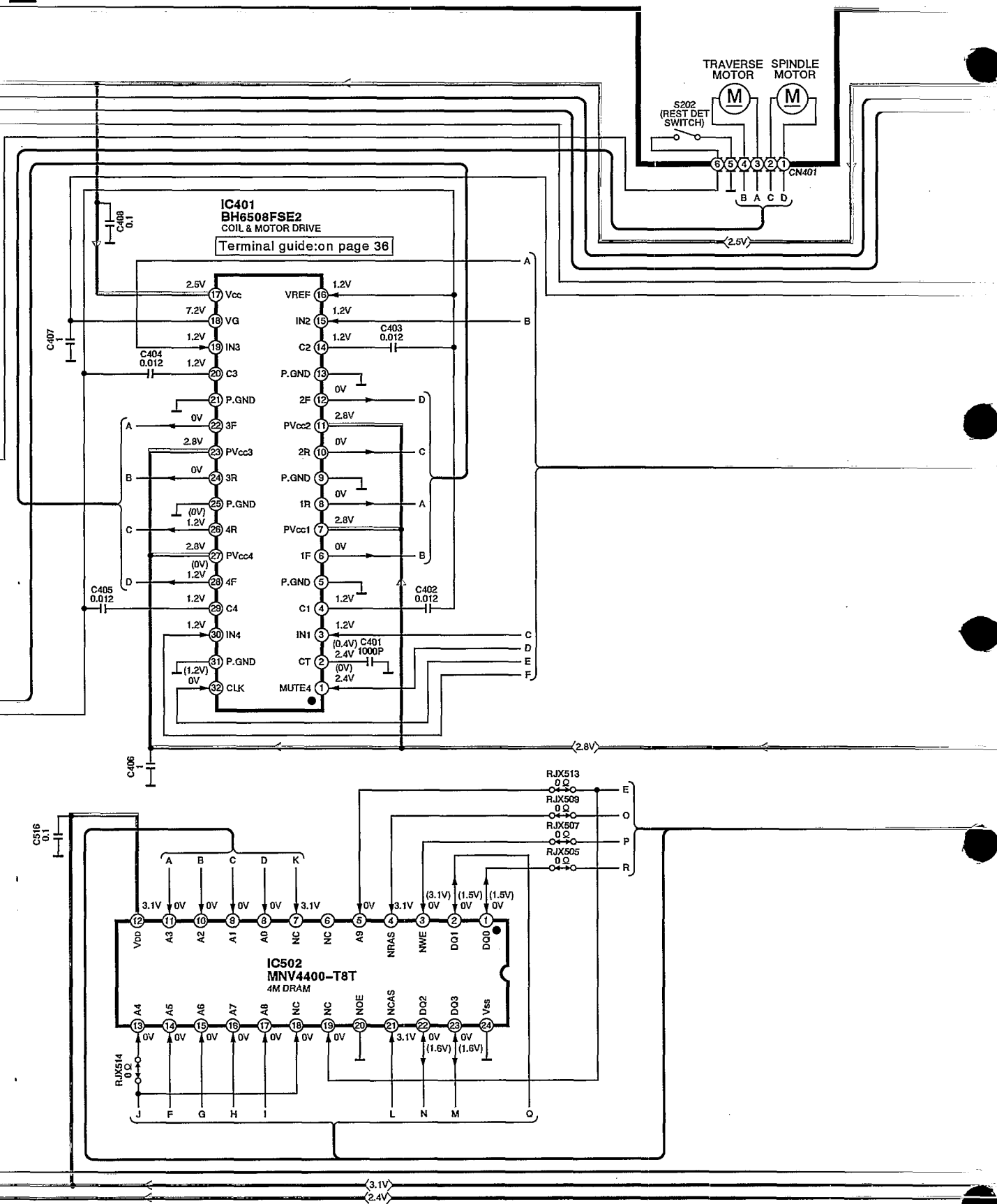

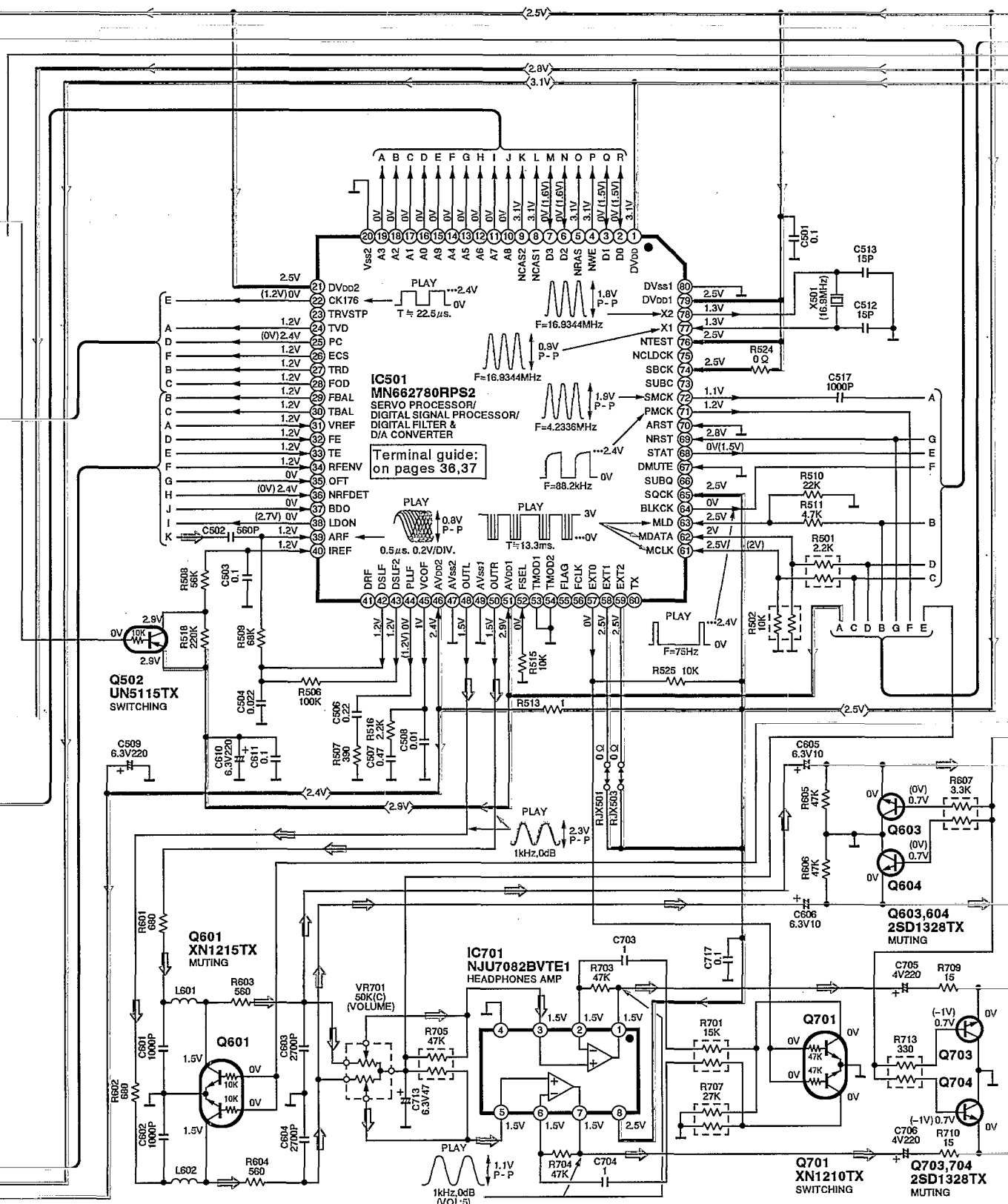

B MAIN CIRCUIT (P.C.Board: on pages 27,28)

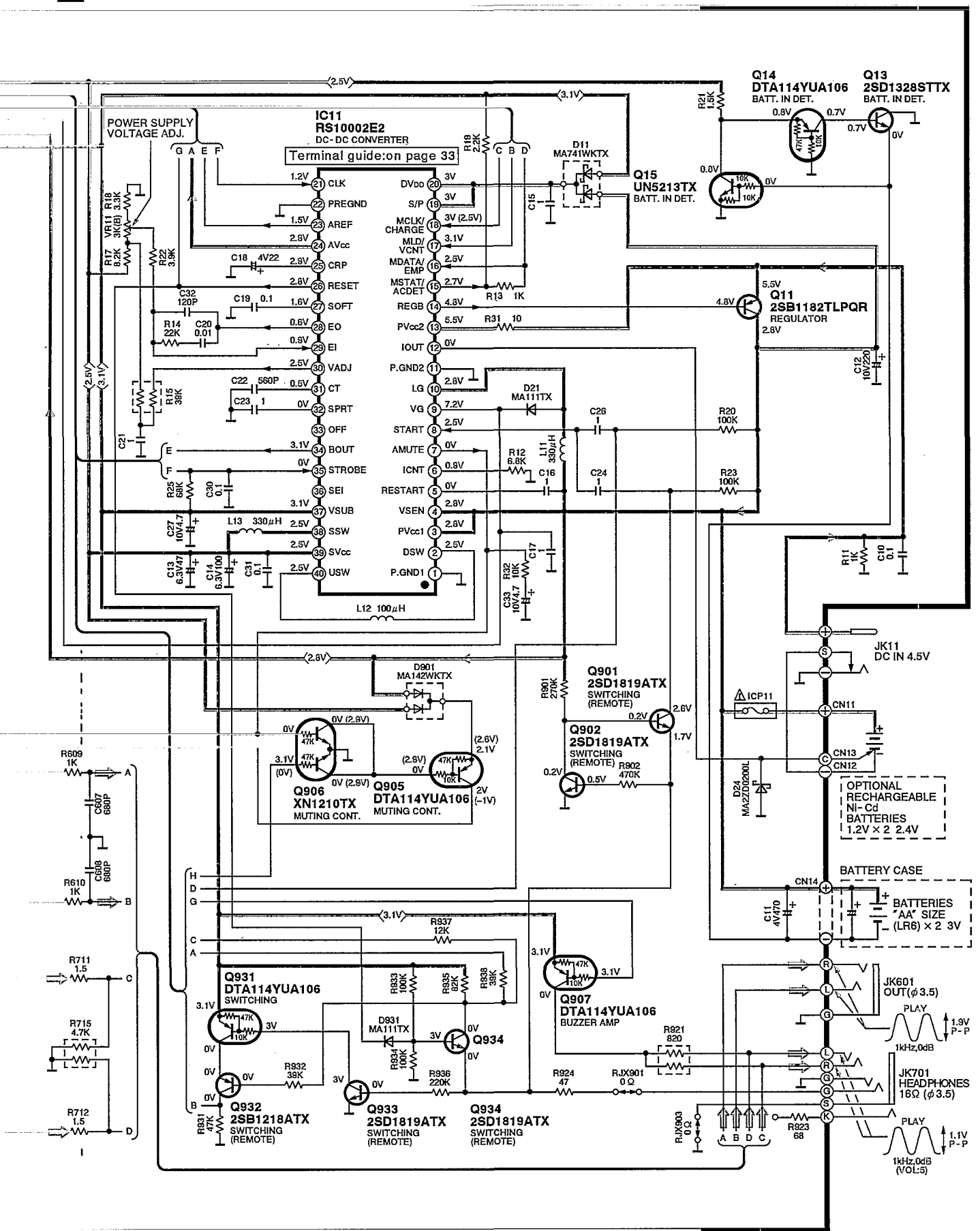

Printed Circuit Board and Wiring Connection Diagram

(This printed circuit board diagram may be modified at any time with the development of new technology.)

B MAIN P.C.B. (SIDE : A)

A OPERATION P.C.B.

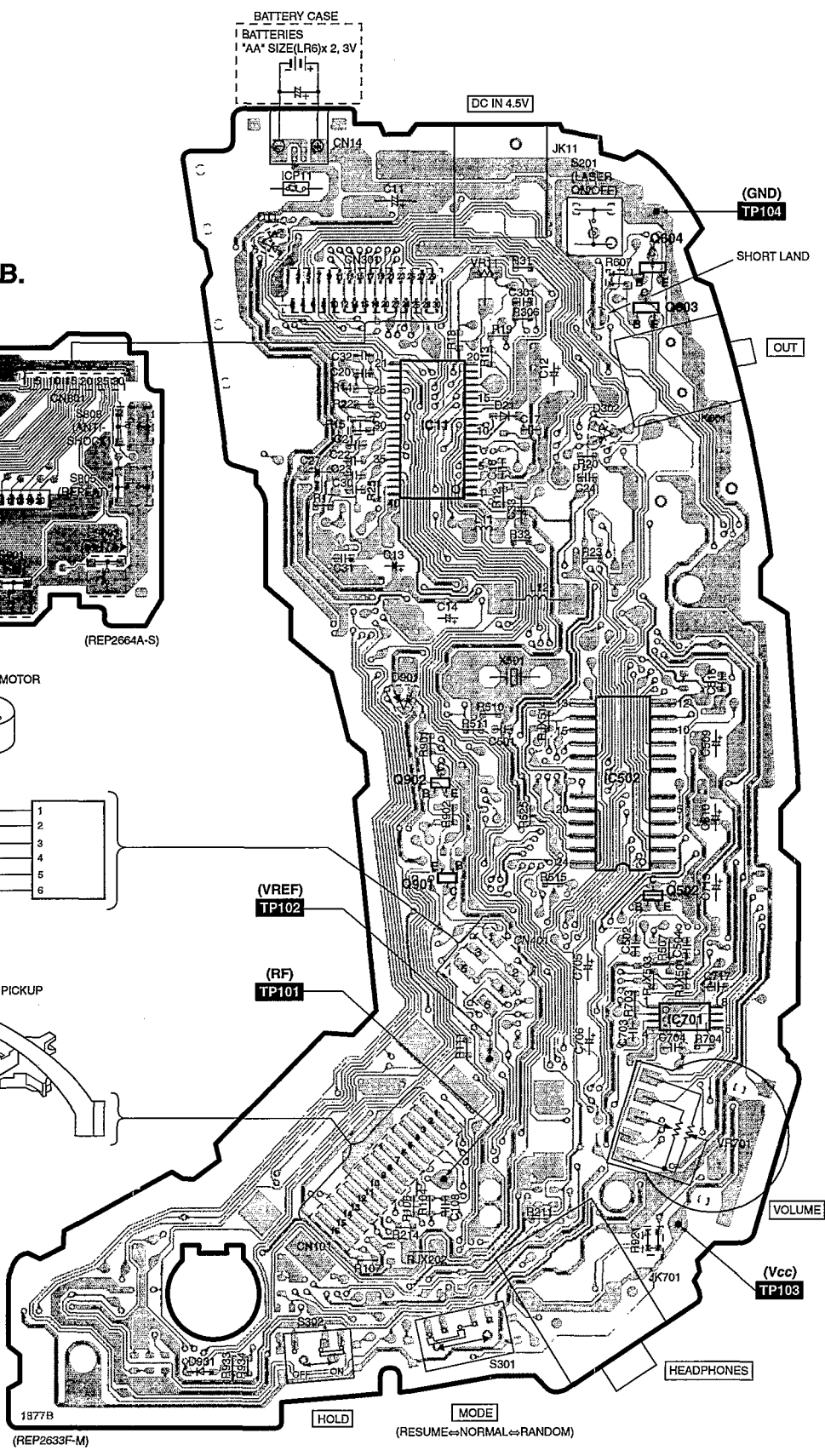
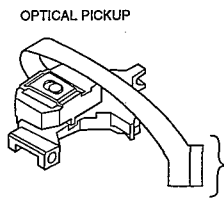
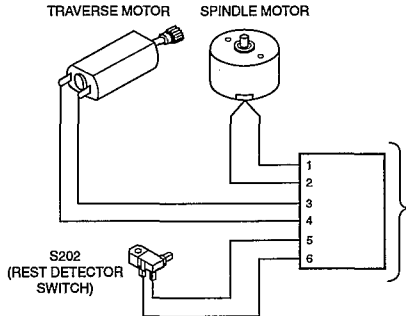
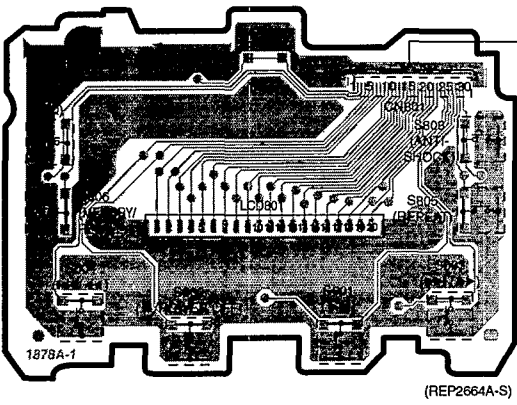

B MAIN P.C.B. (SIDE : B)

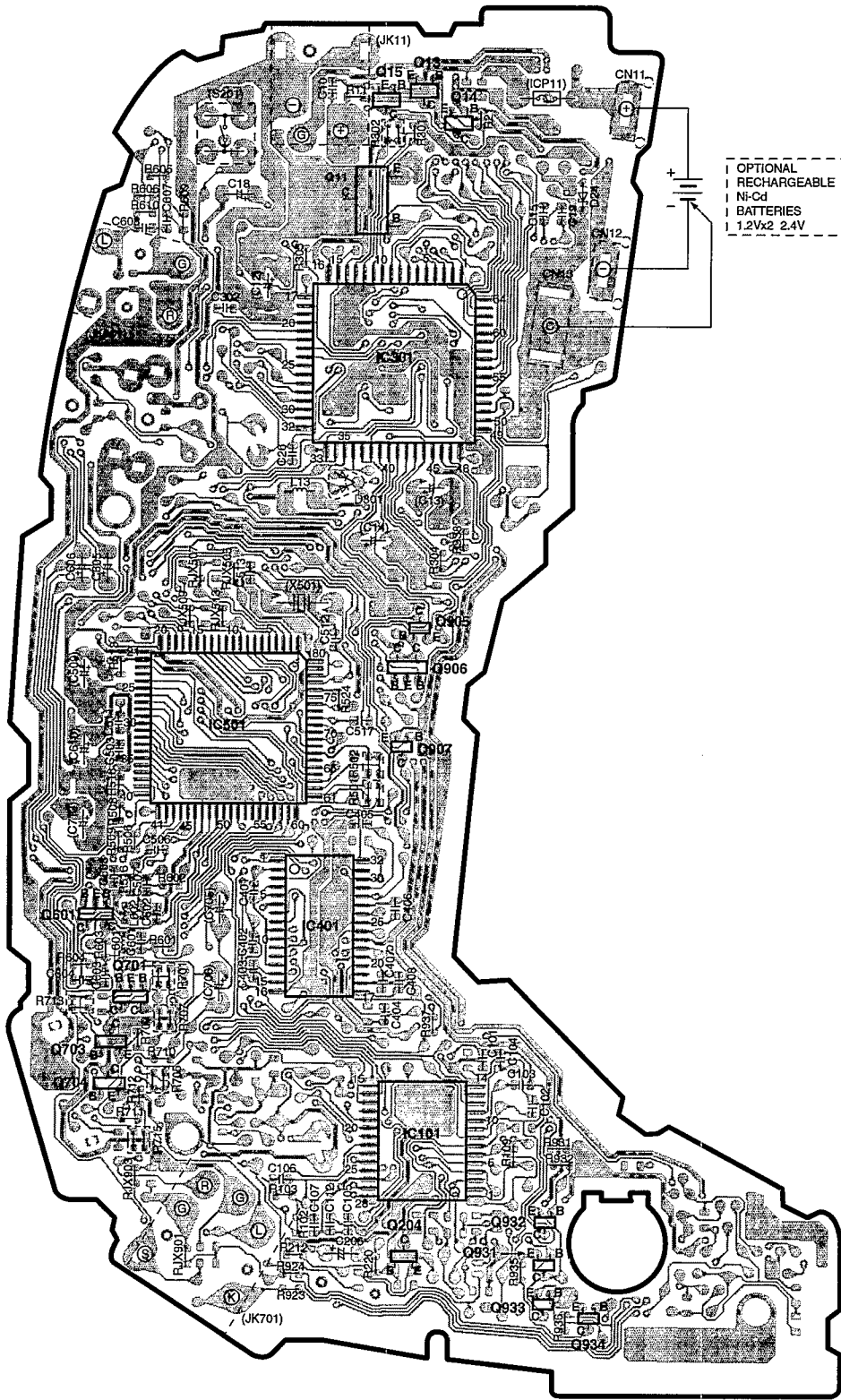

Block Diagram

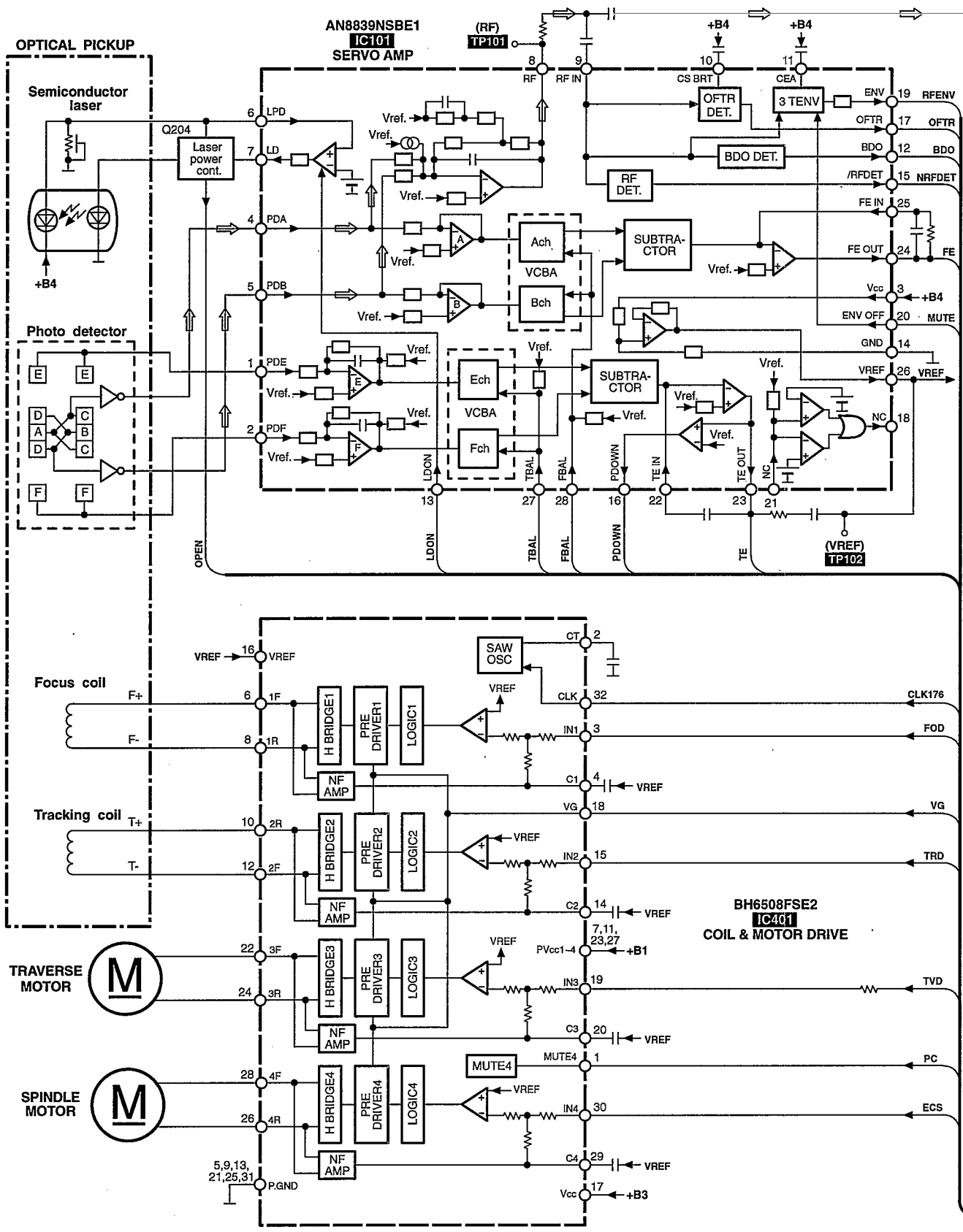

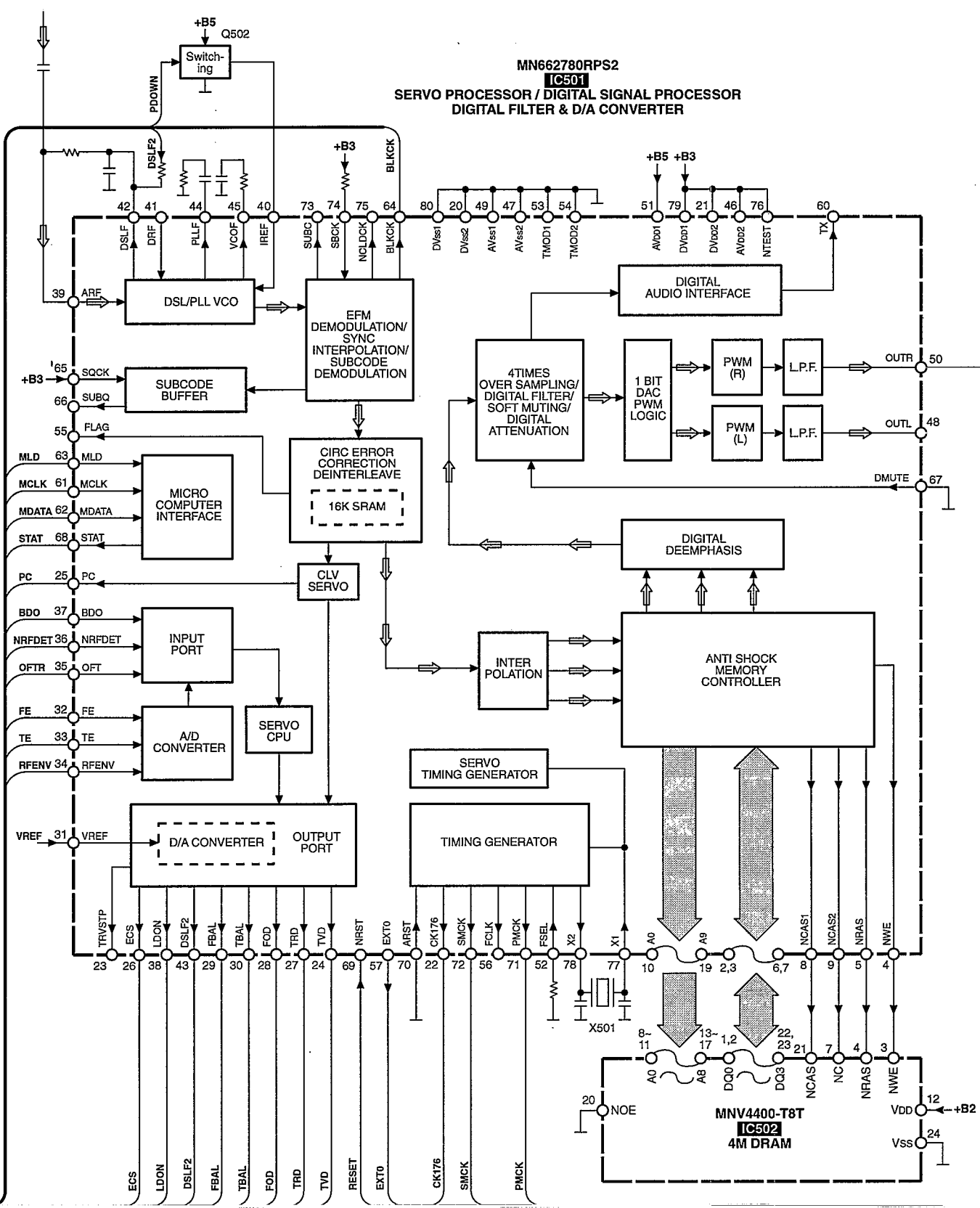

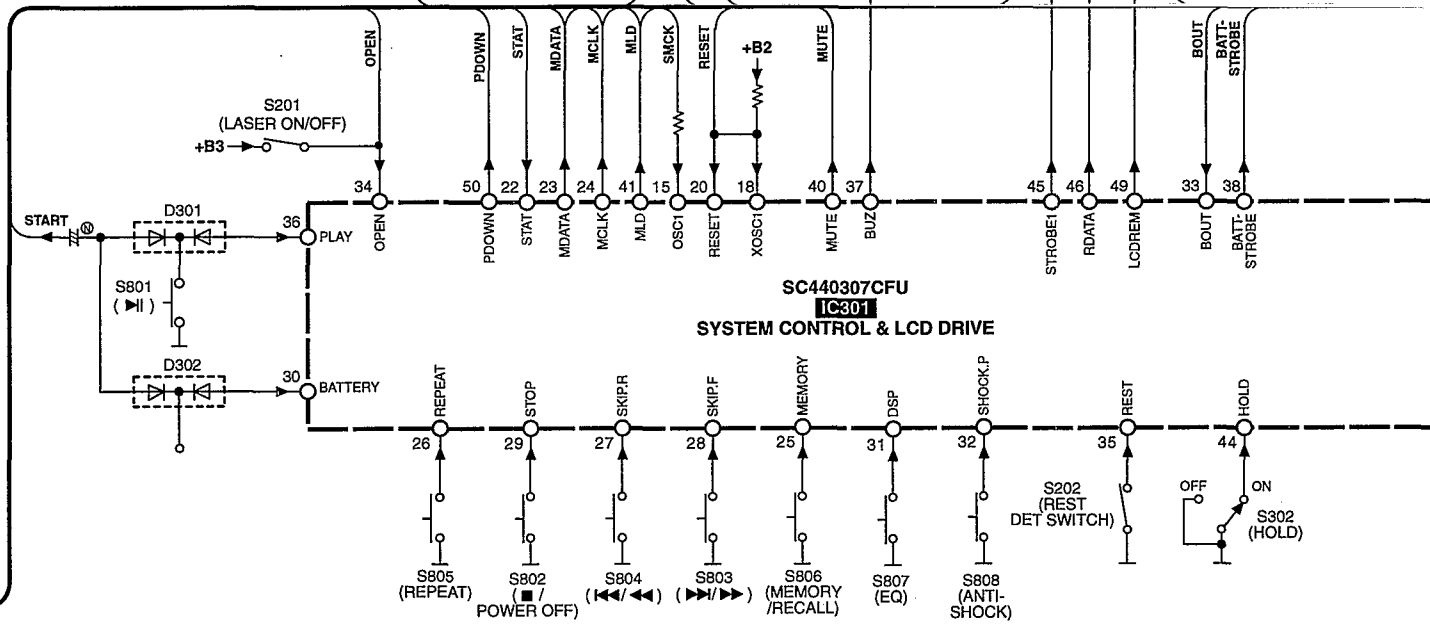
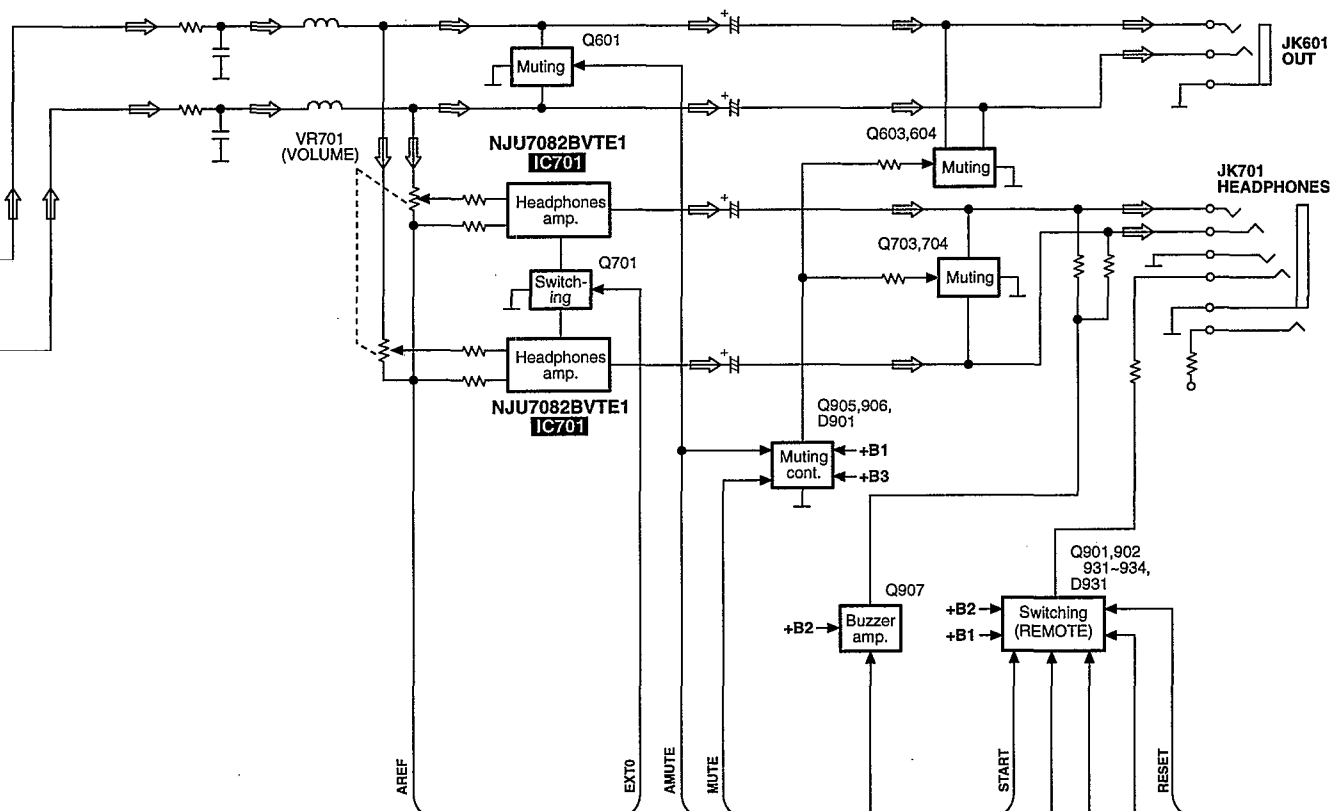

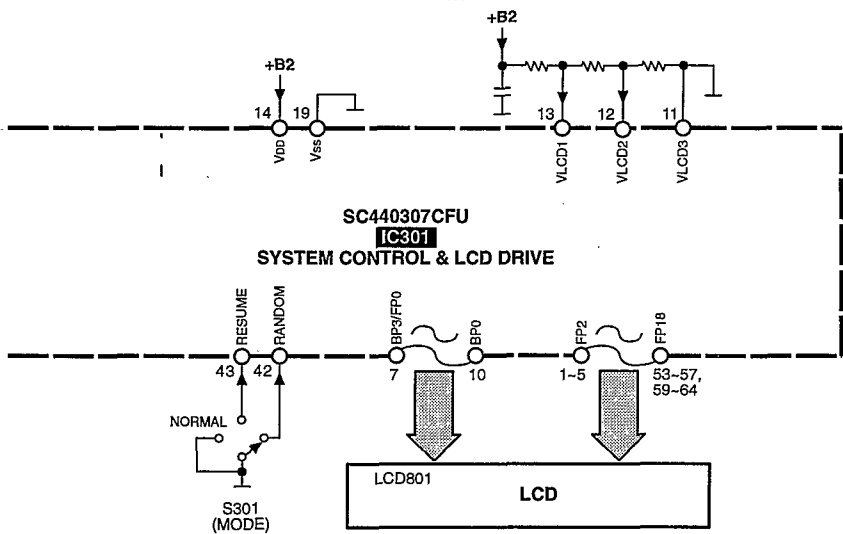
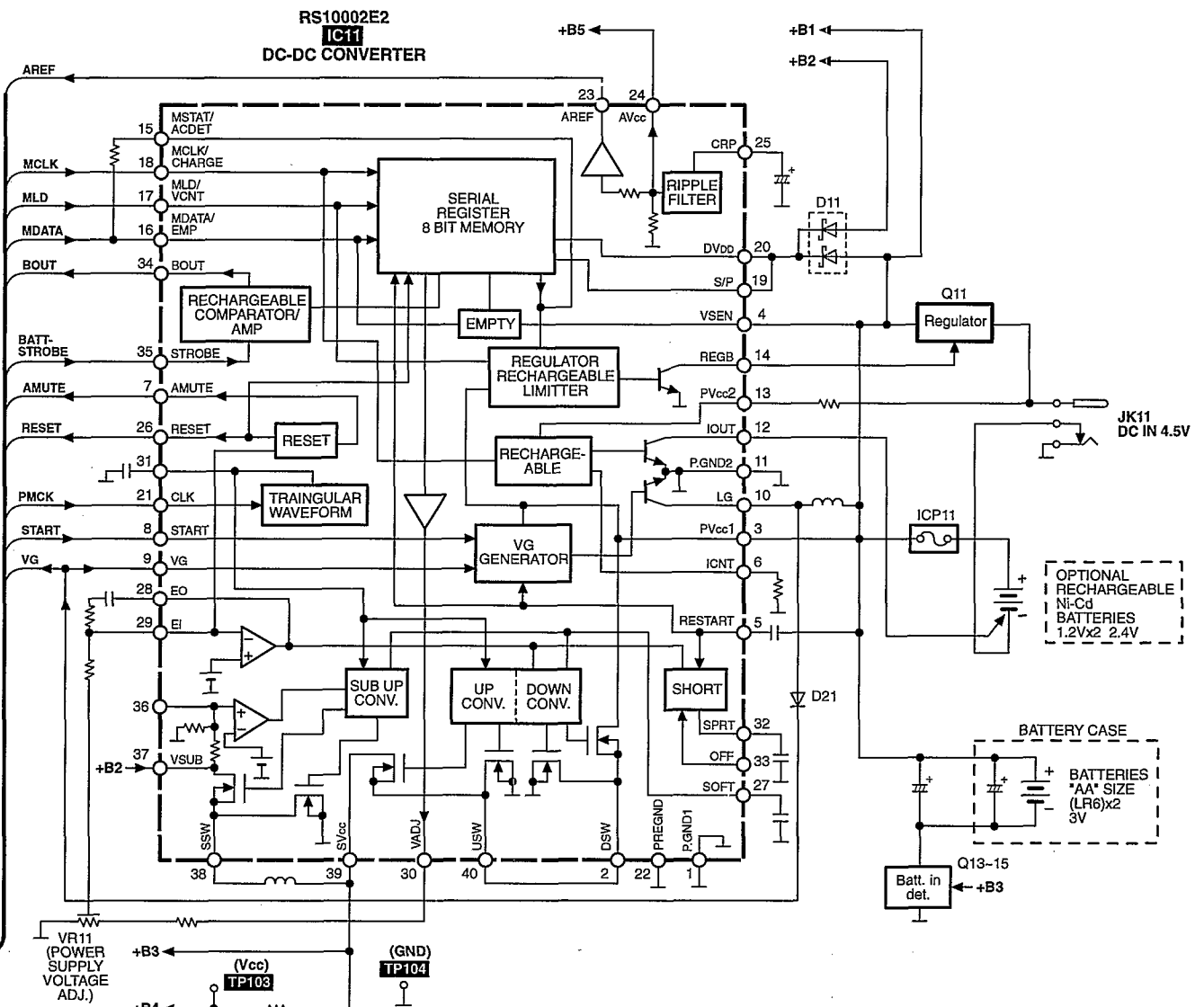

Note \Rightarrow : Audio signal

Terminal Function of IC's

• IC11 (RS10002E2): DC-DC CONVERTER

Pin No.	Mark	I/O Division	Function
1	PGND1	—	GND terminal
2	DSW	O	DC/DC converter coil drive terminal
3	PVCC1	I	Power supply terminal
4	VSEN	I	Empty supply terminal (Power supply terminal)
5	RESTART	I	DC/DC converter drive terminal
6	ICNT	I	Charge current setting terminal
7	AMUTE	O	Muting signal output terminal
8	START	I	DC/DC converter start terminal
9	VG	I	Power supply terminal
10	LG	I	Connected to power supply
11	PGND2	—	GND terminal
12	IOUT	O	Charge signal output terminal
13	PVCC2	I	Power supply terminal
14	REGB	O	Regulator drive signal output terminal
15	MSTAT/ AC DET	O	DC jack detect signal output terminal
16	M DATA/ EMP	O	Decline voltage detect output terminal
17	MLD/VCNT	I	Regulator voltage select input terminal
18	MCLK/ CHARGE	I	Charge ON/OFF terminal
19	S/P	I	Serial/Parallel select terminal (Connected to power supply)
20	DVDD	I	Power supply terminal

Pin No.	Mark	I/O Division	Function
21	CLK	I	Clock signal input terminal
22	PREGND	—	GND terminal
23	AREF	O	Audio reference output terminal
24	AVCC	O	Ripple filter output terminal
25	CRP	I	Connected to capacitor
26	RESET	O	Reset detect signal output terminal
27	SOFT	O	Soft start setting terminal (Connected to capacitor)
28	EO	O	DC/DC converter error amp output terminal
29	EI	I	DC/DC converter error amp input terminal
30	VADJ	O	DC/DC converter variable output terminal
31	CT	O	Triangular wave output terminal (Connected to capacitor)
32	SPRT	O	Power off time-constat setting terminal (Connected to capacitor)
33	OFF	I	DC/DC converter off terminal (Not used, open)
34	BOUT	O	Amp output terminal
35	STROBE	I	Strobe input terminal
36	SEI	I	Sub DC/DC converter, error amp input terminal (Not used, open)
37	VSUB	I	Power supply terminal
38	SSW		
39	SVCC		
40	USW	I	DC/DC converter coil drive terminal

● IC101 (AN8839NSBE1): SERVO AMP

Pin No.	Mark	I/O Division	Function
1	PDE	I	Tracking signal input terminal (1)
2	PDF	I	Tracking signal input terminal (2)
3	Vcc	I	Power supply terminal
4	PDA	I	Focus signal input terminal (1)
5	PDB	I	Focus signal input terminal (2)
6	LPD	I	APC amp input terminal
7	LD	O	APC amp output terminal
8	RF	O	RF summing output terminal
9	RF IN	I	RF signal input terminal
10	CSBRT	I	Capacitor connection terminal for OFTR
11	CEA	I	Capacitor connection terminal for H.P.F. amp
12	BDO	O	Dropout signal output terminal ("H": Dropout)
13	LDON	I	APC control input terminal
14	GND	—	GND terminal

Pin No.	Mark	I/O Division	Function
15	/RFDET	O	RF det. signal output terminal ("L": Det.)
16	PDOWN	O	Power down input terminal
17	OFTR	O	Off track signal output terminal ("H": Off track)
18	NC	—	Not used, open
19	ENV	O	RF envelope signal output terminal
20	ENV OFF	I	ENV control input terminal
21	NC	—	Not used, open
22	TE IN	I	Tracking error amp input terminal
23	TE OUT	O	Tracking error amp output terminal
24	FE OUT	O	Focus error amp output terminal
25	FE IN	I	Focus error amp input terminal
26	VREF	O	Reference voltage output terminal
27	TBAL	I	Tracking balance signal input terminal
28	FBAL	I	Focus balance signal input terminal

● IC301 (SC440307CFU): SYSTEM CONTROL/LCD DRIVE

Pin No.	Mark	I/O Division	Function
1 └ 5	FP6 └ FP2	O	LCD segment signal output terminal
6	FP1	O	LCD segment signal output terminal (Not used, open)
7 └ 10	BP3 └ BP0	O	LCD segment signal output terminal
11	VLCD3	I	Not used, connected to GND
12	VLCD2	I	Power supply terminal

Pin No.	Mark	I/O Division	Function
13	VLCD1	I	Power supply terminal
14	VDD	I	Power supply terminal
15	OSC1	I	System clock (f=4.2336 MHz)
16	OSC2	—	Not used, open
17	XOSC2		
18	XOSC1	I	Connected to reset detect
19	VSS	—	GND terminal

Pin No.	Mark	I/O Division	Function
20	RESET	I	Reset detect input terminal
21	BLKCK	I	Block clock input terminal
22	STAT	I	Status signal input terminal
23	MDATA	I	Command data input terminal
24	MCLK	O	Serial command output terminal
25	MEMORY	I	MEMORY key input terminal
26	REPEAT	I	REPEAT key input terminal
27	SKIP.R	I	SKIP.R key input terminal
28	SKIP.F	I	SKIP.F key input terminal
29	STOP	I	STOP key input terminal
30	BATTERY	I	Batt check key input terminal
31	DSP	I	DSP key input terminal
32	SHOCK.P	I	SHOCK.P key input terminal
33	BOUT	I	Charging control input terminal ("L": OFF)
34	OPEN	I	CD cover open detection terminal
35	REST	I	Rest (innermost position) detection input terminal
36	PLAY	I	PLAY key input terminal
37	BUZ	O	Beep control output terminal
38	BATTSTROBE	O	Rechargeable battery voltage measurement output terminal

Pin No.	Mark	I/O Division	Function
39	WLSRCN/ RSENSE	I	Not used, open
40	MUTE	O	Hard muting output terminal
41	MLD	O	Serial command latch output terminal
42	RANDOM	I	RANDOM switch input terminal
43	RESUME	I	RESUME switch input terminal
44	HOLD	I	HOLD switch input terminal
45	STROBE1	O	Remote control data signal output terminal
46	RDATA	O	Remote control data output terminal
47	TXPOWER	O	Digital out ON output terminal (Not used, open)
48	NC	—	—
49	LCDREM	O	Remote control EL ON output terminal
50	PDOWN	O	Head amp OFF output terminal
51	CHARGE	O	Charge signal output terminal (Not used, open)
52	CS	O	Not used, open
53 } 57	FP18 } FP14	O	LCD segment signal output terminal
58	FP13	O	LCD segment signal output terminal (Not used, open)
59 } 64	FP12 } FP7	O	LCD segment signal output terminal

● IC401 (BH6508FSE2): COIL & MOTOR DRIVE

Pin No.	Mark	I/O Division	Function
1	MUTE4	I	CH4 muting terminal
2	CT	O	Triangular wave output terminal (Connected to capacitor)
3	IN1	I	CH1 input terminal
4	C1	O	CH1 filter terminal (Connected to capacitor)
5	PGND	—	GND terminal
6	1F	O	Focus coil driver output terminal
7	PVCC1	I	Power supply terminal
8	1R	O	Focus coil driver output terminal
9	PGND	—	GND terminal
10	2R	O	Tracking coil driver output terminal
11	PVCC2	I	Power supply terminal
12	2F	O	Tracking coil driver output terminal
13	PGND	—	GND terminal
14	C2	O	CH2 filter terminal (Connected to capacitor)
15	IN2	I	CH2 input terminal
16	VREF	I	Reference voltage output terminal

Pin No.	Mark	I/O Division	Function
17	VCC	I	Power supply terminal
18	VG	I	Power supply terminal
19	IN3	I	CH3 input terminal
20	C3	O	CH3 filter terminal (Connected to capacitor)
21	PGND	—	GND terminal
22	3F	O	Traverse motor drive output terminal
23	PVCC3	I	Power supply terminal
24	3R	O	Traverse motor drive output terminal
25	PGND	—	GND terminal
26	4R	O	Spindle motor drive output terminal
27	PVCC4	I	Power supply terminal
28	4F	O	Spindle motor drive output terminal
29	C4	O	CH4 filter terminal (Connected to capacitor)
30	IN4	I	CH4 input terminal
31	GND	—	GND terminal
32	CLK	I	Clock input terminal

● IC501 (MN662780RPS2): SERVO PROCESSOR/DIGITAL SIGNAL PROCESSOR/DIGITAL FILTER/D/A CONVERTER

Pin No.	Mark	I/O Division	Function
1	DVDD	I	Power supply terminal
2	D0	I/O	Data 0 input/output terminal
3	D1	I/O	Data 1 input/output terminal
4	NWE	O	Write enable output terminal
5	NRAS	O	RAS control signal output terminal
6	D2	I/O	Data 2 input/output terminal
7	D3	I/O	Data 3 input/output terminal
8	NCAS1	O	CAS control 0 signal output terminal
9	NCAS2	O	Address/0 signal output terminal

Pin No.	Mark	I/O Division	Function
10	A8	O	Address 8 ~ 4, 9, 0 ~ 3 output terminal
11	A7		
14	A4		
15	A9		
16	A0		
17	A1	—	GND terminal
18	A2		
19	A3		
20	VSS2	—	GND terminal
21	DVDD2	I	Power supply terminal
22	CK176	O	Clock output terminal (88.2 kHz/44.1 kHz)
23	TRVSTP	O	Traverse motor stop control terminal ("H": stop mode) (Not used, open)

Pin No.	Mark	I/O Division	Function
24	TVD	O	Traverse drive signal output terminal
25	PC	O	Spindle motor drive signal output terminal ("L": ON)
26	ECS	O	Spindle motor drive signal output terminal
27	TRD	O	Tracking drive kick pulse output terminal
28	FOD	O	Focus drive output terminal
29	FBAL	O	Focus balance adj. output terminal
30	TBAL	O	Tracking balance adj. output terminal
31	VREF	I	Reference voltage input terminal
32	FE	I	Focus error signal input terminal
33	TE	I	Tracking error signal input terminal
34	RFENV	I	RF envelope signal input terminal
35	OFT	I	OFF track signal input terminal ("H": off track)
36	NRFDET	I	RF detect signal input terminal ("L": detect)
37	BD0	I	Drop out signal input terminal ("H": drop out)
38	LDON	O	Laser on signal output terminal ("H": ON)
39	ARF	I	RF signal input terminal
40	IREF	I	Reference current input terminal
41	DRF	I	DSL bias terminal (Not used, open)
42	DSL F	O	DSL loop filter output terminal
43	DSL F2	O	DSL anbalance current correction output terminal
44	PLL F	O	PLL loop filter output terminal
45	VCO F	O	Loop filter output terminal
46	AVDD2	I	Power supply terminal
47	AVSS2	—	GND terminal
48	OUTL	O	Audio Lch output terminal
49	AVSS1	—	GND terminal
50	OUTR	O	Audio Rch output terminal
51	AVDD1	I	Power supply terminal
52	FSEL	—	Noise filter select terminal ("H": ON, "L": OFF)
53	TMOD1	—	Terminal mode select 1 terminal ("L": normal)

Pin No.	Mark	I/O Division	Function
54	TMOD2	—	Terminal mode select 2 terminal ("L": normal)
55	FLAG	—	Flag signal output terminal (Not used, open)
56	FCLK	—	Crystal frame clock signal output terminal (Not used, open)
57	EXT0	O	Expansion port 0 output terminal
58	EXT1	—	Expansion port 1 output terminal (Not used, open)
59	EXT2	—	Expansion port 2 output terminal (Not used, open)
60	TX	O	Digital audio interface signal output terminal (Not used, open)
61	MCLK	I	Micon command clock signal input terminal
62	MDATA	I	Micon command data input terminal
63	MLD	I	Micon command load signal input terminal ("L": load)
64	BLKCK	O	Sub code block clock signal output terminal (f BLKCK=75 kHz)
65	SQCK	I	Sub code Q resistor colck input terminal
66	SUBQ	—	Sub code Q data output terminal (Not used, open)
67	DMUTE	I	Muting input terminal ("H": mute) (Not used, connected to GND)
68	STAT	O	Status signal output terminal (RESY, CLVS, NTTSTOP, SQCK, FLAG6, SENSE, NTLOCK, BSSEL, SUBQ DATA, CD TEXT DATA, ANTI SHOCK LOAD DATA)
69	NRST	I	Reset input terminal ("L": reset)
70	ARST	I	Test terminal ("L": normal)
71	PMCK	O	Clock signal output terminal (88.2 kHz)
72	SMCK	O	Clock signal output terminal (4.2336 MHz)
73	SUBC	O	Sub code output terminal (Not used, open)
74	SBCK	I	Sub code output clock input terminal
75	NCLDCK	O	Sub code frame clock output terminal (f CLDCK= 7.35 kHz) (Not used, open)
76	NTEST	I	Test terminal ("H": normal)
77	X1	I	Crystal oscillator input terminal (f=16.9344 MHz)
78	X2	O	Crystal oscillator output terminal (f=16.9344 MHz)
79	DVDD1	I	Power supply terminal
80	DVSS1	—	GND terminal

■ Cabinet Parts Location

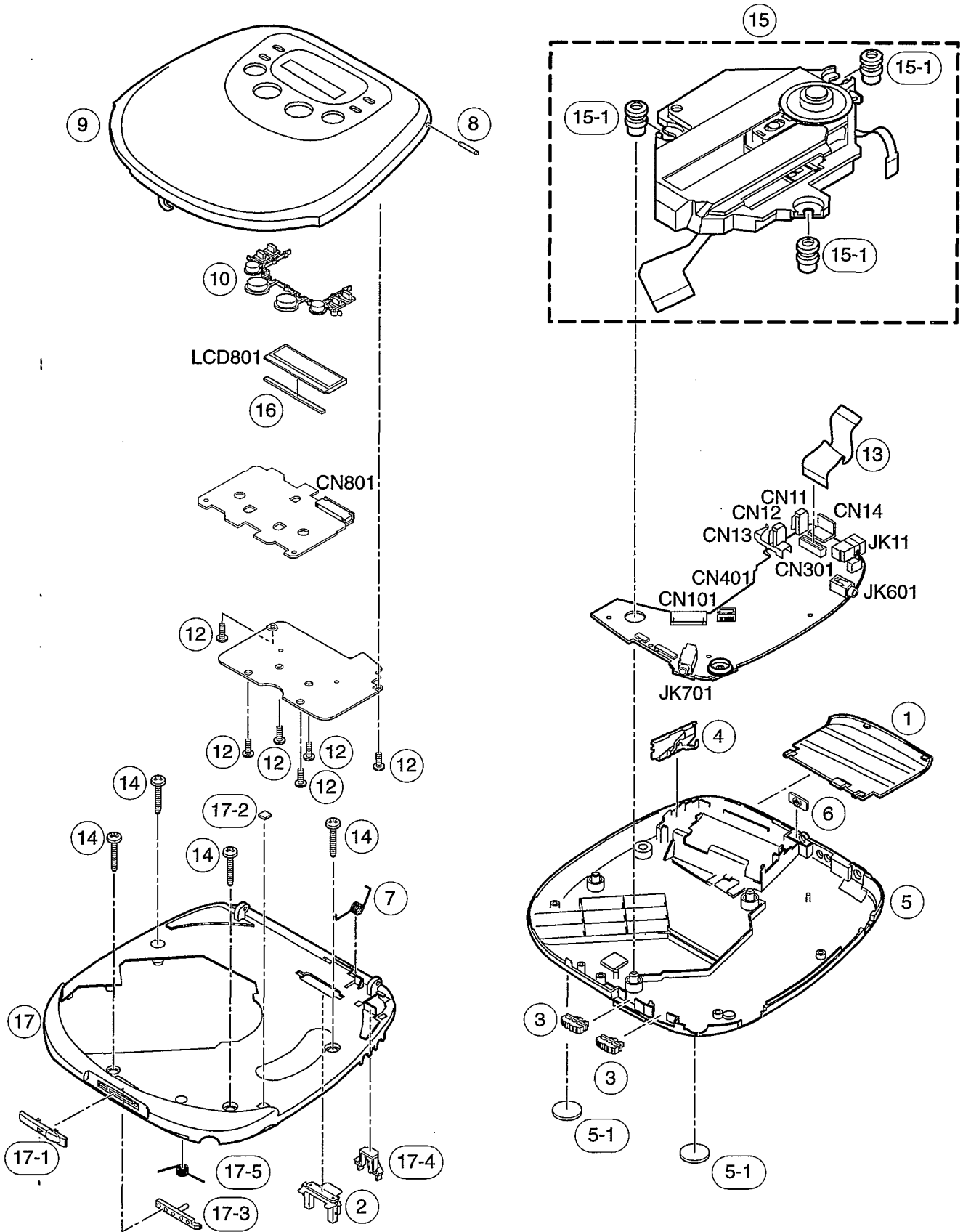

Replacement Parts List

Notes:

* Important safety notice:

Components identified by Δ mark have special characteristics important for safety.

Furthermore, special parts which have purposes of fire-retardant (resistors), high-quality sound (capacitors), low-noise (resistors), etc. are used.

When replacing any of components, be sure to use only manufacturer's specified parts shown in the parts list.

* The parenthesized indications in the Remarks columns specify the areas. (Refer to the cover page for area.)

Parts without these indications can be used for all areas.

* Warning: This product uses a laser diode. Refer to caution statements on page 2.

* Capacity values are in microfarads (μ F) unless specified otherwise, P=Pico-farads (pF), F=Farads (F)

* Resistance values are in ohms, unless specified otherwise, 1K=1,000 (OHM), 1M=1,000k (OHM)

* The marking <RTL> indicates that the Retention Time is limited for this item. After the discontinuation of this assembly in production, the item will continue to be available for a specific period of time. The retention period of availability is dependant on the type of assembly, and in accordance with the laws governing part and product retention. After the end of this period, the assembly will no longer be available.

* (A) and (S) marks in Part Name & Description indicate color of the unit.

[(A): Blue, (S): Silver]

* "<IA>, <IB>, <IC>, <ID>" marks in Remarks indicate language of instruction manual.

<IA>: English, <IB>: English/Spanish/Swedish, <IC>: German/Italy/French, <ID>: Dutch/Danish/Russian]

* This item is not attached to merchandise, but it is supplied as a replacement parts.

Ref.No.	Part No.	Part Name & Description	Pcs	Remarks
1	RKK0102-K	BATTERY COVER	1	
2	RMR1142-K	FPC HOLDER	1	
3	RGV0199-H	SLIDE KNOB	2	
4	RJC93020	COMMON BATTERY TERMINAL	1	
5	RFKJLSX300EB	BOTTOM CABINET ASS'Y	1	(EB)
5	RFKJLSX300EG	BOTTOM CABINET ASS'Y	1	(EG)
5	RFKJLSX300GN	BOTTOM CABINET ASS'Y	1	(GN)
5-1	RKA0063-K	FOOT	2	
6	RMA0677	REAR ORNAMENT PLATE	1	
7	RME0239	OPEN SPRING	1	
8	RMS0570	SHAFT	1	
9	RYF0475A-A	CD COVER ASS'Y (A)	1	(EB, EG)
9	RYF0475A-S	CD COVER ASS'Y (S)	1	(EB, EG, GN)
10	RGU1611-H	OPERATION BUTTON	1	
12	RHE5119YA	SCREW	6	
13	RJB1944A	FFC (30P)	1	
14	XTN17+6GFZ	SCREW	4	
Δ 15	RAE0145Z	TRAVERSE DECK	1	
15-1	RMG0449-H	FLOATING RUBBER	3	
16	RSQ0056	ZEBRA RUBBER	1	
17	RYK0781A-H	INTERMEDIATE CABI. ASS'Y	1	
17-1	RGV0221-H	OPEN KNOB	1	
17-2	RMG0466-K	CUSHION RUBBER	1	
17-3	RMR1141-K	LOCK PLATE	1	
17-4	RMR1143-K	STOPPER	1	
17-5	RME0265	SPRING	1	
A1	RFA0627-K4	BATTERY CASE	1	
Δ A2	RFEA401E-3S	AC ADAPTOR	1	(EG)
Δ A2	RFEA403A-S	AC ADAPTOR	1	(GN)

Ref.No.	Part No.	Part Name & Description	Pcs	Remarks
Δ A2	RFEA404B-1W	AC ADAPTOR	1	(EB)
A3	RFEV316P-K1S	STEREO EARPHONES	1	
A4	RFEV015PCKS	REMOTE CONTROLLER	1	
A5	RQA0117	WARRANTY CARD	1	(EB) (EG)
A5	RQX7433ZA	WARRANTY CARD	1	(GN)
A6	RQC80169	SERVICENTER LIST	1	
A7	RQT4285-H	INSTRUCTION MANUAL	1	(EG) <ID>
A7	RQT4282-B	INSTRUCTION MANUAL	1	(EB) (GN) <IA>
A7	RQT4283-E	INSTRUCTION MANUAL	1	(EG) <IB>
A7	RQT4284-D	INSTRUCTION MANUAL	1	(EG) <IC>
A8※	RKB205ZA-0	EAR PADS	1	
C10	ECUZNC104ZFY	16V 0.1U	1	
C11	ECEV0GA471P	4V 470U	1	
C12	ECA1AAK221XH	10V 220U	1	
C13	RCE0JSA4701X	6.3V 47U	1	
C14	ECEA0JKA101I	6.3V 100U	1	
C15-17	ECUVNA105ZFY	10V 1U	3	
C18	ECST0GY226RR	4V 22U	1	
C19	ECUZNC104ZFY	16V 0.1U	1	
C20	ECUV1E103KBV	25V 0.01U	1	
C21	ECUVNA105ZFY	10V 1U	1	
C22	ECUV1H561KBV	50V 560P	1	
C23, 24	ECUVNA105ZFY	10V 1U	2	
C26	ECUVNA105ZFY	10V 1U	1	
C27	ECST1AY475RR	10V 4.7U	1	
C30	ECUV1C104KBV	16V 0.1U	1	
C31	ECUZNC104ZFY	16V 0.1U	1	
C32	ECUV1H121JCV	50V 120P	1	
C33	ECST1AY475RR	10V 4.7U	1	
C101	ECUV0J474KBV	6.3V 0.47U	1	
C102	ECUV1C104KBV	16V 0.1U	1	
C103	ECUV1E223KBV	25V 0.022U	1	
C104	ECUV1E103KBV	25V 0.01U	1	
C105	ECUV1E223KBV	25V 0.022U	1	
C106	ECUV1H271KBV	50V 270P	1	
C107	ECUV1H332KBV	50V 3300P	1	
C108	ECUV1H391KBV	50V 390P	1	
C112	ECUZNC104ZFY	16V 0.1U	1	
C206	ECST0GY226RR	4V 22U	1	
C301	ECUZNC104ZFY	16V 0.1U	1	
C302	ECUVNA105ZFY	10V 1U	1	
C401	ECUV1H102KBV	50V 1000P	1	
C402-05	ECUV1E123KBV	25V 0.012U	4	
C406, 07	ECUVNA105ZFY	10V 1U	2	
C408	ECUZNC104ZFY	16V 0.1U	1	
C501	ECUZNC104ZFY	16V 0.1U	1	
C502	ECUV1H561KBV	50V 560P	1	
C503	ECUZNC104ZFY	16V 0.1U	1	
C504	ECUV1E223KBV	25V 0.022U	1	
C506	ECUVNA224KBV	10V 0.22U	1	
C507	ECUV0J474KBV	6.3V 0.47U	1	
C508	ECUV1E103KBV	25V 0.01U	1	
C509	ECEA0JKA221I	6.3V 220U	1	
C512, 13	ECUV1H150DCV	50V 15P	2	
C516	ECUZNC104ZFY	16V 0.1U	1	
C517	ECUV1H102KBV	50V 1000P	1	
C601, 02	ECUV1H102KBV	50V 1000P	2	
C603, 04	ECUV1H272KBV	50V 2700P	2	
C605, 06	ECST0JY106RR	6.3V 10U	2	
C607, 08	ECUV1H681KBV	50V 680P	2	
C610	ECA0JAK221XH	6.3V 220U	1	
C611	ECUZNC104ZFY	16V 0.1U	1	
C703, 04	ECUVNA105KBN	10V 1U	2	
C705, 06	ECEA0GPD221I	4V 220U	2	
C713	ECA0JAK470XH	6.3V 47U	1	
C717	ECUZNC104ZFY	16V 0.1U	1	
CN11, 12	RJC93015-1	BATTERY TERMINAL	2	
CN13	RJH5104	RECHARGE BATT. TERMINAL	1	
CN14	RJH9209-1	BATT. CASE TERMINAL	1	
CN101	RJS2A6126T	CONNECTOR (16P)	1	
CN301	RJS2A6130T	CONNECTOR (30P)	1	
CN401	RJS2A5106T1	CONNECTOR (6P)	1	
CN801	RJS2A4530T	CONNECTOR (30P)	1	

Ref.No.	Part No.	Part Name & Description	Pcs	Remarks	Ref.No.	Part No.	Part Name & Description	Pcs	Remarks
D11	MA741WKT	DIODE	1		R106, 07	ERJ3GEYJ330V	1/16W 33	2	
D21	MA1111TX	DIODE	1		R109	ERJ3GEY0R00V	1/16W 0	1	
D24	MA22D020DL	DIODE	1		R111	ERJ3GEY0R00V	1/16W 0	1	
D301, 02	MA142WKT	DIODE	2		R211	ERJ3GEYJ223V	1/16W 22K	1	
D901	MA142WKT	DIODE	1		R212	ERJ3GEYJ2R2V	1/16W 2. 2	1	
D931	MA1111TX	DIODE	1		R214	ERJ3GEY0R00V	1/16W 0	1	
IC11	RS10002E2	IC	1		R220	ERJ3GEYJ1R0V	1/16W 1	1	
IC101	AN8839NSBE1	IC	1		R301	ERJ3GEYJ473V	1/16W 47K	1	
IC301	SC440307CFU	IC	1		R302	EXBV4V473JV	1/32W 47K	1	
IC401	BH6508FSE2	IC	1		R304	ERJ3GEYJ102Z	1/16W 1K	1	
IC501	MN662780RPS2	IC	1		R305	ERJ3GEYJ104Z	1/16W 100K	1	
IC502	MNV4400-T8T	IC	1		R306	ERJ3GEYJ392V	1/16W 3. 9K	1	
IC701	NJU7082BVT1E1	IC	1		R501	EXBV4V222JV	1/32W 2. 2K	1	
△ ICP11	UNH000700A	IC PROTECTOR	1		R502	EXBV4V103JV	1/32W 10K	1	
JK11	RJJ43K09-C	JACK, DC IN	1		R506	ERJ3GEYJ104Z	1/16W 100K	1	
JK601	RJJD3S5ZB-C	JACK, OUT	1		R507	ERJ3GEYJ391V	1/16W 390	1	
JK701	RJJ36T02-C	JACK, HEADPHONES	1		R508	ERJ3GEYJ563V	1/16W 56K	1	
L11	RLQU331KT-W	COIL, CHOKE	1		R509	ERJ3GEYJ683V	1/16W 68K	1	
L12	RLQS101KT1-T	COIL, CHOKE	1		R510	ERJ3GEYJ223V	1/16W 22K	1	
L13	RLQU331KT-W	COIL, CHOKE	1		R511	ERJ3GEYJ472V	1/16W 4. 7K	1	
L601, 02	RLBV102V-Y	COIL, CHOKE	2		R513	ERJ3GEYJ1R0V	1/16W 1	1	
LCD801	RSL5192-T	LCD DISPLAY	1		R515	ERJ3GEYJ103Z	1/16W 10K	1	
P1	RPK1014	PACKING CASE(S)	1	(EB, EG, GN)	R516	ERJ3GEYJ222V	1/16W 2. 2K	1	
P1	RPK1037	PACKING CASE(A)	1	(EB, EG)	R518	ERJ3GEYJ224V	1/16W 220K	1	
P2	RPQ0753	SPACER	1		R524	ERJ3GEY0R00V	1/16W 0	1	
P3	RPQ0836	PAD	1		R525	ERJ3GEYJ103Z	1/16W 10K	1	
P4	RPF0046	PROTECTION BAG(F. B.)	1		R601, 02	ERJ3GEYJ681V	1/16W 680	2	
P5	RPF0111	PROTECTION BAG(UNIT)	1		R603, 04	ERJ3GEYJ561V	1/16W 560	2	
PCB1	REP2633F-M	MAIN P. C. B.	1	<RTL>	R605, 06	ERJ3GEYJ473V	1/16W 47K	2	
PCB2	REP2664A-S	SUB P. C. B.	1	<RTL>	R607	EXBV4V332JV	1/32W 3. 3K	1	
Q11	2SB1182TLPQR	TRANSISTOR	1		R609, 10	ERJ3GEYJ102Z	1/16W 1K	2	
Q13	2SD1328STTX	TRANSISTOR	1		R701	EXBV4V153JV	1/32W 15K	1	
Q14	DTA114YUA106	TRANSISTOR	1		R703, 04	ERJ3GEYJ473V	1/16W 47K	2	
Q15	UN5213TX	TRANSISTOR	1		R705	EXBV4V473JV	1/32W 47K	1	
Q204	2SB709ATX	TRANSISTOR	1		R707	EXBV4V273JV	1/32W 27K	1	
Q502	UN5115TX	TRANSISTOR	1		R709, 10	ERJ3GEYJ150V	1/16W 15	2	
Q601	XN1215TX	TRANSISTOR	1		R711, 12	ERJ3GEYJ1R5V	1/16W 1. 5	2	
Q603, 04	2SD1328TX	TRANSISTOR	2		R713	EXBV4V331JV	1/32W 330	1	
Q701	XN1210TX	TRANSISTOR	1		R715	EXBV4V472JV	1/32W 4. 7K	1	
Q703, 04	2SD1328TX	TRANSISTOR	2		R901	ERJ3GEYJ274V	1/16W 270K	1	
Q901, 02	2SD1819ATX	TRANSISTOR	2		R902	ERJ3GEYJ474V	1/16W 470K	1	
Q905	DTA114YUA106	TRANSISTOR	1		R921	EXBV4V821JV	1/32W 820	1	
Q906	XN1210TX	TRANSISTOR	1		R923	ERJ3GEYJ680V	1/16W 68	1	
Q907	DTA114YUA106	TRANSISTOR	1		R924	ERJ3GEYJ470V	1/16W 47	1	
Q931	DTA114YUA106	TRANSISTOR	1		R931	ERJ3GEYJ473V	1/16W 47K	1	
Q932	2SB1218ATX	TRANSISTOR	1		R932	ERJ3GEYJ393V	1/16W 39K	1	
Q933, 34	2SD1819ATX	TRANSISTOR	2		R933, 34	ERJ3GEYJ104Z	1/16W 100K	2	
R11	ERJ3GEYJ102Z	1/16W 1K	1		R935	ERJ3GEYJ823V	1/16W 82K	1	
R12	ERJ3GEYJ682V	1/16W 6. 8K	1		R936	ERJ3GEYJ224V	1/16W 220K	1	
R13	ERJ3GEYJ102Z	1/16W 1K	1		R937	ERJ3GEYJ123V	1/16W 12K	1	
R14	ERJ3GEYJ223V	1/16W 22K	1		R938	ERJ3GEYJ393V	1/16W 39K	1	
R15	EXBV4V393JV	1/32W 39K	1		RJX202	ERJ3GEY0R00V	CHIP JUMPER	1	
R17	ERJ3GEYJ822V	1/16W 8. 2K	1		RJX501	ERJ3GEY0R00V	CHIP JUMPER	1	
R18	ERJ3GEYJ332V	1/16W 3. 3K	1		RJX503	ERJ3GEY0R00V	CHIP JUMPER	1	
R19	ERJ3GEYJ222V	1/16W 2. 2K	1		RJX505	ERJ3GEY0R00V	CHIP JUMPER	1	
R20	ERJ3GEYJ104Z	1/16W 100K	1		RJX507	ERJ3GEY0R00V	CHIP JUMPER	1	
R21	ERJ3GEYJ152V	1/16W 1. 5K	1		RJX509	ERJ3GEY0R00V	CHIP JUMPER	1	
R22	ERJ3GEYJ392V	1/16W 3. 9K	1		RJX513, 14	ERJ3GEY0R00V	CHIP JUMPER	2	
R23	ERJ3GEYJ104Z	1/16W 100K	1		RJX901	ERJ3GEY0R00V	CHIP JUMPER	1	
R25	ERJ3GEYJ683V	1/16W 68K	1		RJX903	ERJ3GEY0R00V	CHIP JUMPER	1	
R31	ERJ3GEYJ100V	1/16W 10	1		S201	ESE11SV6	SW, LASER ON/OFF	1	
R32	ERJ3GEYJ103Z	1/16W 10K	1		S202	ESE11HS4	SW, REST DET	1	
R102	ERJ3GEYJ563V	1/16W 56K	1		S301	RSS3A007-1A	SW, MODE	1	
R103	ERJ3GEYJ472V	1/16W 4. 7K	1		S302	RSS2A010-1A	SW, HOLD	1	
R104	ERJ3GEYJ683V	1/16W 68K	1		S801-08	RS60038-P	SW, PUSH	8	
					SA1	SZZP1054C	PLAYABILITY DISC	1	
					SA2	SZZP1056C	UNEVEN TEST DISC	1	
					VR11	RRN3A05B33WL	V. R. , VOLTAGE ADJ.	1	
					VR701	EVUTUF811CS4	V. R. , VOLUME	1	
					X501	RSXZ16W9M04T	OSCILLATOR	1	

■ Packaging

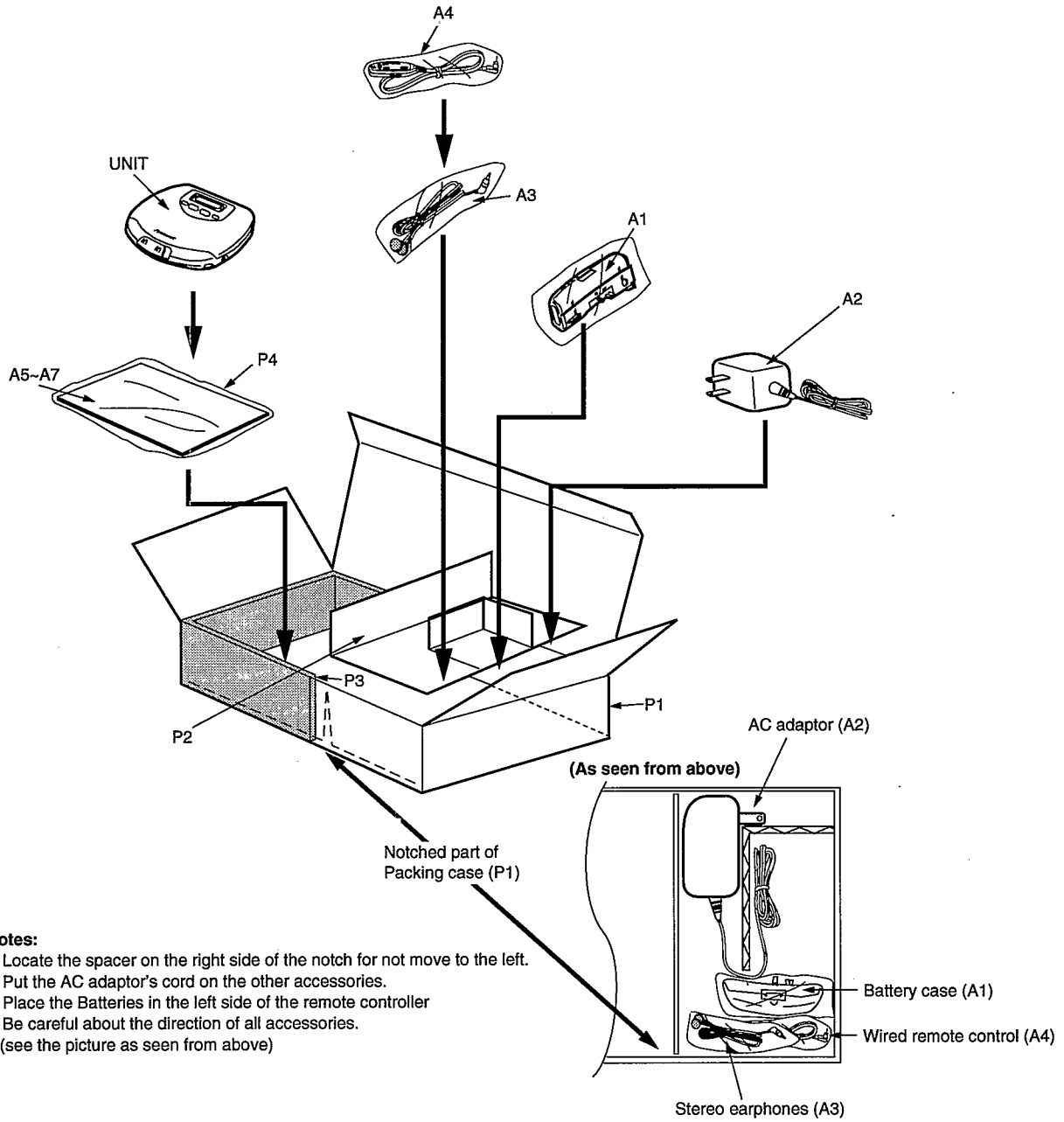

Notes:

- Locate the spacer on the right side of the notch for not move to the left.
- Put the AC adaptor's cord on the other accessories.
- Place the Batteries in the left side of the remote controller
- Be careful about the direction of all accessories.
(see the picture as seen from above)

MEMO

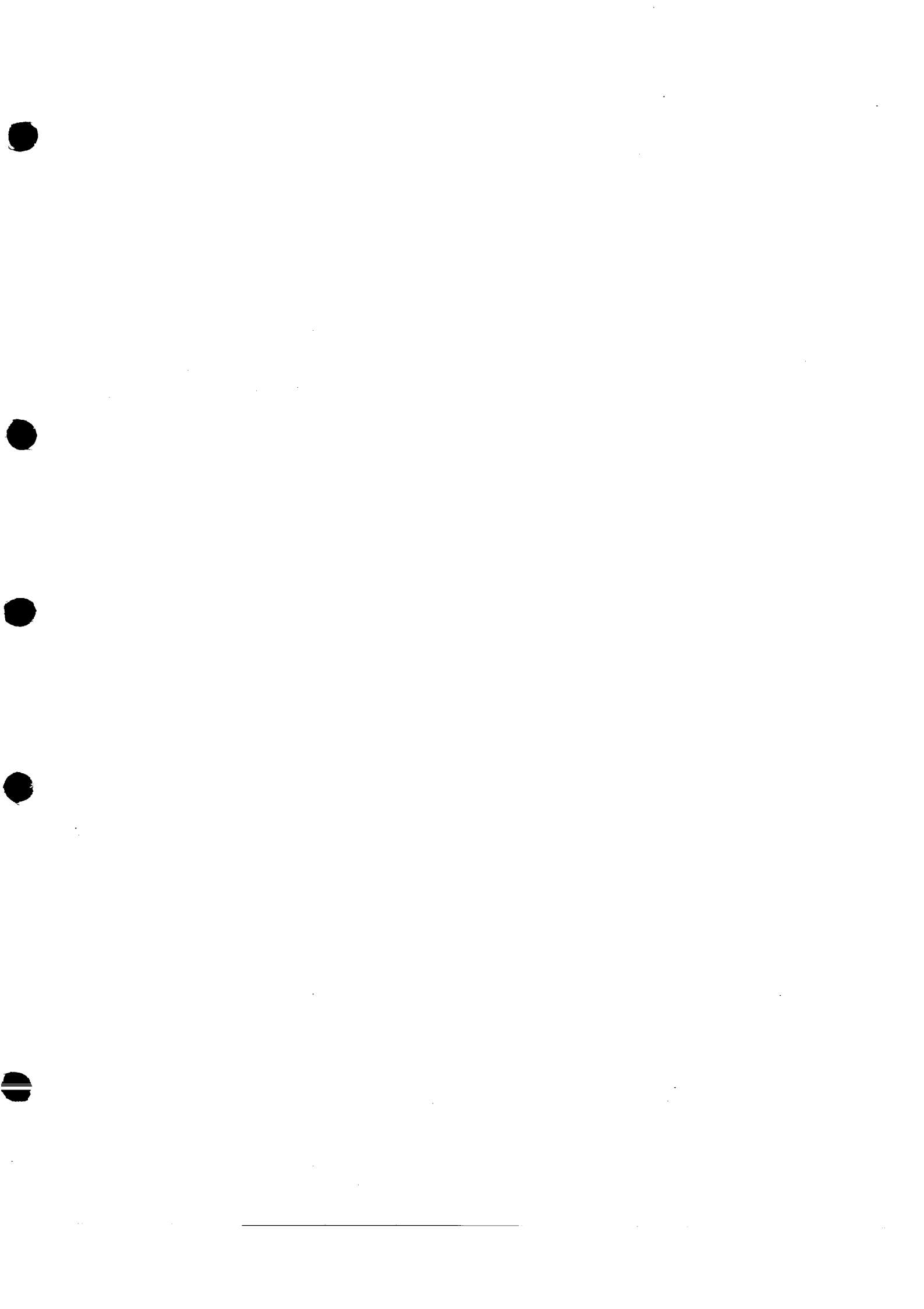

623
