

Service Manual

Portable CD Player

COMPACT
disc
DIGITAL AUDIO
DIGITAL
MASH[※]
 multi-stage noise shaping

SL-XP240

※ • MASH is a trademark of NTT.

Colour

(K)...Black Type

Area

Suffix for Model No.	Area	Colour
(E)	Europe.	(K)
(EB)	Great Britain.	
(EG)	Germany and Italy.	
(GC)	Asia, Latin America, Middle Near East and Africa.	
(GN)	Oceania.	

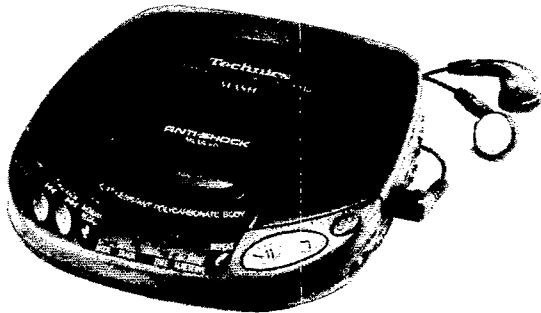
TRAVERSE DECK: RAE0141Z MECHANISM SERIES
SPECIFICATIONS
Audio

No. of channels: 2 channels (left and right, stereo)
Output voltage: 0.6 V (50 k Ω) ϕ 3.5 stereo mini jack
Frequency response: 20~20,000 Hz (+0.5 dB, -1.5 dB)
S/N: more than 94 dB*
Wow and flutter: Below measurable limit
DA converter: 1 bit, MASH*
Headphone output level: max. 9 mW+9 mW/16 Ω (variable)
 stereo mini jack ϕ 3.5
 8 times over sampling

Digital filter:

8 times over sampling

Signal Format

Correction system: Technics New
 Super Decoding Algorithm

Pickup

Type: One beam
Light source: Semiconductor laser
Wavelength: 780 nm
Lens: Glass pressed lens

Playing time;

[When used in hold mode, at 25°C temperature and on flat and stable surface.]

Batteries used	Anti-shock OFF/ON
Rechargeable batteries	About 3 hours/ About 2 hours 30 minutes
Panasonic alkaline dry cell batteries	About 10 hours/ About 7 hours/ 30 minutes

The play time may be less depending on the operating conditions.

Recharging time;

About 3 hours

General
Power requirement:

AC; with an included panasonic AC adaptor
 RFEA401E-2S (E, EG)
 RFEA404B-1W (EB)
 RFEA403Z-S (GC)
 RFEA403A-S (GN)
 Batteries; DC 3 V (two "AA" size batteries, not included)
 (Panasonic R6P/LR6 or equivalent, not included)
 Rechargeable Batteries; DC 2.4 V with an optional Panasonic Rechargeable Batteries (SH-CDB8D set of 2)
 Car Battery; with an optional Panasonic car adaptor (SH-CDC9)
 DC 4.5 V \diamond \ominus \diamond

DC IN:

Operation temperature range: 0°C—40°C

Rechargeable

temperature range: 5°C—40°C

Power supply:

DC 4.5 V

Power consumption:

Using AC adaptor; 5.5 W/5.7W(Anti-shock OFF/ON)

Dimensions (W×H×D):

128×29×140 mm

Weight:

225 g without batteries
 270 g with batteries

*These specifications were measured in the anti-shock OFF mode.

Note: Design and specifications are subject to change without notice. Weight and dimensions are approximate.

Technics[®]

© 1996 Matsushita Electric Industrial Co., Ltd.
 All rights reserved. Unauthorized copying and distribution is a violation of law.

⚠ WARNING

This service information is designed for experienced repair technicians only and is not designed for use by the general public. It does not contain warnings or cautions to advise non-technical individuals of potential dangers in attempting to service a product. Products powered by electricity should be serviced or repaired only by experienced professional technicians. Any attempt to service or repair the product or products dealt with in this service information by anyone else could result in serious injury or death.

CONTENTS

	Page		Page
PRECAUTION OF LASER DIODE	2	AUTOMATIC ADJUSTMENT RESULTS	
ACCESSORIES	3	DISPLAY FUNCTION (SELF-CHECK FUNCTION)	13, 14
LOCATION OF CONTROLS	3	MEASUREMENTS AND ADJUSTMENTS	14, 15
POWER SUPPLY PREPARATIONS	3	BLOCK DIAGRAM	16~19
ACCIDENTAL OPERATION PREVENTION FUNCTION	4	SCHEMATIC DIAGRAM	20~24
SEQUENTIAL PLAY	4~6	PRINTED CIRCUIT BOARD AND	
USING THE UNIT WITH OPTIONAL ACCESSORIES	6	WIRING CONNECTION DIAGRAM	25
CAUTIONS	7	REPAIRING THE PRINTED RESISTOR	26
HANDLING PRECAUTIONS FOR TRAVERSE DECK	8	TERMINAL GUIDE	27~32
OPERATION CHECKS AND MAIN		REPLACEMENT PARTS LIST	32
COMPONENT REPLACEMENT PROCEDURES	9~11	CABINET PARTS LOCATION	33
CHECKING THE OPERATION PROBLEMS ON		REPLACEMENT PARTS LIST	34,35
THE TRAVERSE DECK (OPTICAL PICKUP)	12	PACKAGING	35
		RESISTORS AND CAPACITORS	36

PRECAUTION OF LASER DIODE

CAUTION: This product utilizes a laser diode with the unit turned "on", invisible laser radiation is emitted from the pickup lens.

Wave length: 780 nm
Maximum output radiation power from pickup: 100 μW/VDE

Laser radiation from the pickup lens is safety level, but be sure the followings:

1. Do not disassemble the optical pickup unit, since radiation from exposed laser diode is dangerous.
2. Do not adjust the variable resistor on the pickup unit. It was already adjusted.
3. Do not look at the focus lens using optical instruments.
4. Recommend not to look at pickup lens for a long time.

ACHTUNG: Dieses Produkt enthält eine Laserdioden. Im eingeschalteten Zustand wird unsichtbare Laserstrahlung von der Lasereinheit abgestrahlt.

Wellenlänge: 780 nm
Maximale Strahlungsleistung der Lasereinheit: 100 μW/VDE

Die Strahlung an der Lasereinheit ist ungefährlich, wenn folgende Punkte beachtet werden:

1. Die Lasereinheit nicht zerlegen, da die Strahlung an der freigelegten Laserdioden gefährlich ist.
2. Den werkseitig justierten Einstellregler der Lasereinheit nicht verstellen.
3. Nicht mit optischen Instrumenten in die Fokussierlines blicken.
4. Nicht über längere Zeit in die Fokussierlines blicken.

ADVARSEL: I dette a apparat anvendes laser.

VARO! Avattaessa ja suojelukitus ohitettaessa olet aittilina näkymätön lasersäteilylle. Älä katso säteeseen.

VARNING! Osynlig laserstråling når denna del är öppnad och spårren är urkopplad. Betrakta ej strålen.

ADVERSEL! Usynlig laserstråling når deksel åpnes og sikkerheds-lås brytes. Unngå eksponering for strålen.

(Tuotteen pohjassa)
(Apparatens undersida)
(Produktets underside)

DANGER-invisible laser radiation when open and interlock defeated. AVOID DIRECT EXPOSURE TO BEAM.

(Bottom of the product)

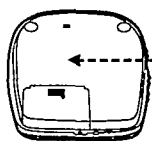

Bottom of the unit
Parte inferior del aparato
Apparatens undersida
Komponentens underside
Produktets underside

ADVARSEL: USYNLIG LASERSTRÅLING VED ÅBNING, NÅR SIKKERHEDSAFBRYDERE ER UDE AF FUNKTION. UNDGÅ UDSÆTTELSE FOR STRÅLING.

(Påsat under apparatet)

**CLASS 1
LASER PRODUCT**

**LUOKAN 1 LASERLAITE
KLASS 1 LASER APPARAT**

CAUTION!
THIS PRODUCT UTILIZES A LASER. USE OF CONTROLS OR ADJUSTMENTS OR PERFORMANCE OF PROCEDURES OTHER THAN THOSE SPECIFIED HEREIN MAY RESULT IN HAZARDOUS RADIATION EXPOSURE.
DO NOT OPEN COVERS AND DO NOT REPAIR YOURSELF. REFER SERVICING TO QUALIFIED PERSONNEL.

Marking sign is located on bottom of the unit.

ACCESSORIES

- AC adaptor1 pc.
RFEA401E-2S [for (E, EG) areas.] RFEA404B-1W [for (EB) area.] RFEA403Z-S [for (GC) area.] RFEA403A-S [for (GN) area.]
- Power plug adaptor1 pc.
SJP5213-2 [for (GC) area.]
- Stereo earphones1 pc.
RFEV317A-KS [for (E, EB, EG, GC, GN,) areas.]

LOCATION OF CONTROLS

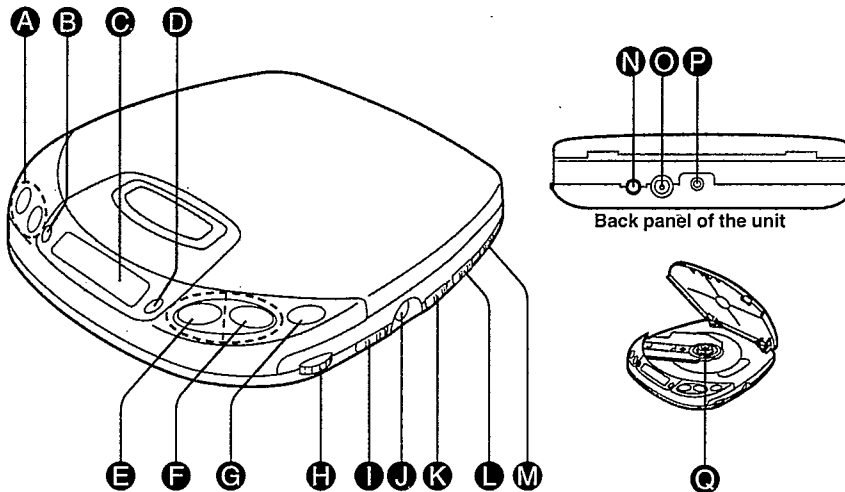

- A** Skip/search buttons (◀◀, ▶▶) •SKIP/SEARCH
- B** Memory/recall button (MEMORY/RECALL)
- C** Display
- D** Repeat button (REPEAT)
- E** Play/pause button (▶||)
- F** Stop/power off button (■/POWER OFF)
- G** Open button (OPEN)
- H** Headphones volume control (VOLUME)
- I** XBS switch (XBS)
- J** Headphones jack (⌀) 16Ω ϕ 3.5
- K** Play mode selector (MODE)
- L** Hold switch (HOLD)
- M** Anti-shock switch (ANTI-SHOCK)
- N** Out jack (OUT)
- O** DC in jack (DC IN 4.5 V ⚡)
- P** Hole for car insulator mounting screw
- Q** Push button (PUSH)

POWER SUPPLY PREPARATIONS

Refer to the specifications (back cover) for the duration of the play time provided when rechargeable or dry cell batteries are used.

Using rechargeable batteries

Make sure that the rechargeable batteries have been recharged before use.

Recharging procedure

1 Place the rechargeable batteries inside the unit.

(No batteries other than RP-BP60/SH-CDB8D can be recharged.)

If the battery compartment lid becomes disengaged, position it horizontally and press it back into position.

2 Connect the AC adaptor.

(For areas except Continental Europe.)

The AC voltage is different according to the area. Be sure to set the proper voltage in your area before use.

(For details, please refer to the attached sheet.)

- Ⓐ DC IN jack (DC IN 4.5 V ⚡)
- Ⓑ Back panel of the unit
- Ⓒ AC power outlet
- Ⓓ AC adaptor

Note

The configuration of the AC adaptor differs according to the area.

- It takes about 3 hours to fully recharge the batteries.

3 Upon completion of the recharging, disconnect the AC adaptor from the DC IN jack and power outlet.

Removing the batteries [A]

Push the batteries upward in the direction of the arrow to remove them.

- The batteries can be used for about 10 months (300 times) if they are used every day. They will need to be replaced if the duration of their operation drops drastically.
- You can operate the unit with the AC adaptor while recharging the batteries, but it will lengthen the recharging time.
- Recharging should be performed at 5°C~40°C.
- While recharging, the AC adaptor and rechargeable batteries may get warm. This is normal.

Using the dry cell batteries (not included)

Disconnect the AC adaptor and then install two LR6 (UM-3) type alkaline batteries.

The batteries are inserted and removed in the same way as for the rechargeable batteries.

Using the AC adaptor

Connect the AC adaptor supplied. Refer to the section on "Using the rechargeable batteries" for details on the connections.

Note

The unit is in the standby condition when the AC adaptor is connected. The primary circuit is always "live" as long as the AC adaptor is connected to an electrical outlet.

Using the car adaptor (not included)

Be sure to obtain the car adaptor (SH-CDC9), available as an optional accessory. The batteries can be recharged inside the car using the car adaptor.

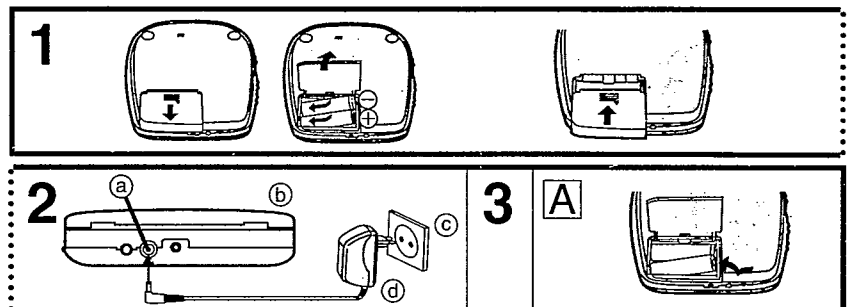

ACCIDENTAL OPERATION PREVENTION FUNCTION

This function prevents the unit from operating even if a control button is pressed in error. (The disc lid can still be opened and closed.) Use the function to prevent the following situations:

Example 1:

While the unit is not in use, the power is inadvertently turned on and the batteries run down.

Example 2:

Play is interrupted while the unit is in use.

To use the accidental operation prevention function

Set HOLD to the HOLD position. **A**

a Hold mode

"hold" indicator

If the unit is in the hold mode, the "hold" indicator appears when any of the unit's function buttons (except OPEN) is pressed.

When the unit is turned off

The "hold" indicator appears only when **▶ ||** is pressed.

Before operating the buttons

Be absolutely sure to move HOLD to release the unit from the hold mode.

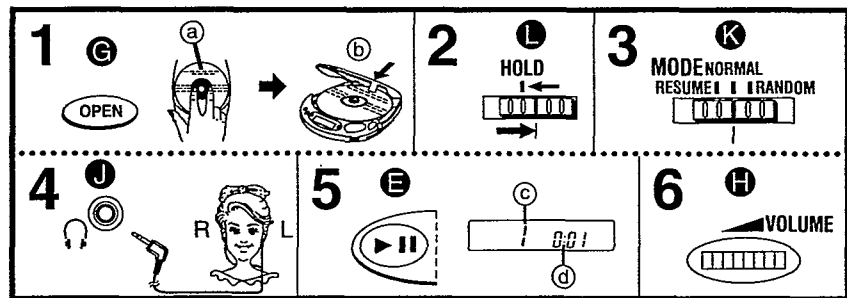
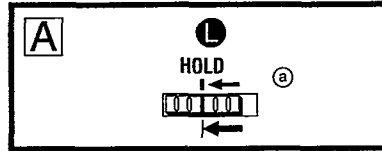

SEQUENTIAL PLAY

1 Press OPEN to open the lid, and insert the disc.

Label must face upward.



Press the area near the center hole of the disc until it clicks into position.

Close the lid.



2 Release the hold mode.

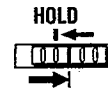

3 Set MODE to NORMAL.



5 Press ▶ ||.

Play now starts.

Track number in play

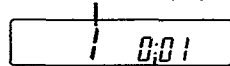

Elapsed playing time of each track

4 Connect the stereo earphones to the jack.

(Plug in firmly.)



6 Adjust the volume level.

(If the unit has been connected to the car audio system, adjust the volume between 4 and 6 on the unit, then adjust the volume level on the system.)

Play stops automatically when all the tracks have been played.

Removing the disc

After the disc has stopped rotating, open lid, press PUSH to release the disc. (Do not open the lid during play.)

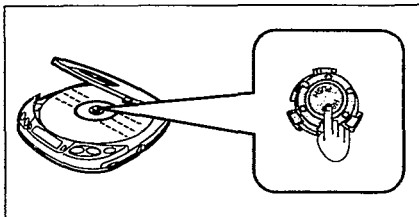

Note

Do not put anything inside the unit.

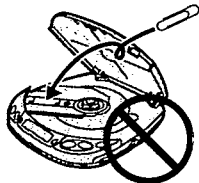

Automatic Shut-OFF function

When the unit is left for about 10 minutes in the stop or pause mode, this function automatically shuts off the power in order to prevent the batteries, etc. from discharging needlessly.

1 Press OPEN to open the lid, and insert the disc.

- Ⓐ Label must face upward.
Press the area near the center hole of the disc until it clicks into position.
- Ⓑ Close the lid.

2 Release the hold mode.

3 Set MODE to NORMAL.

4 Connect the stereo earphones to the jack. (Plug in firmly.)

5 Press ►||.

Play now starts.

- Ⓒ Track number in play
- Ⓓ Elapsed playing time of each track
Play stops automatically when all the tracks have been played.

6 Adjust the volume level.

(If the unit has been connected to the car audio system, adjust the volume level between 4 and 6 on the unit, then adjust the volume level on the system.)

For your reference:

“no disc” display

This appears for about 30 seconds when a disc has not been inserted or when a disc has not been inserted properly and then ►|| is pressed.

Operation	Button	Display
Pause: Press during play/press again to resume play	►	7 0:16
To stop play: Press during play Stop mode	■	Total number of tracks 10 44:48 Total playing time
To turn off the unit: Press during stop mode Off mode	■	
Skip forward/backward (skip function): Press during play Rapid forward/backward (search function): Keep depressed during play	►►: Forward direction ◄◄: Backward direction	—

Skip and search functions

- During program play the tracks are skipped in the forward or backward direction in the programmed sequence.
- During program play, random play or 1-track repeat play, only the track being played is searched.
- During random play, it is not possible to skip to the track which has already been played.

For your reference:

“no disc” display

This appears for about 30 seconds when a disc has not been inserted or when a disc has not been inserted properly and then ►|| is pressed.

“open” display

This appears for about 10 minutes after the lid is opened. (It does not appear when the unit is turned off.)

“open” display

This appears for about 10 minutes after the lid is opened. (It does not appear when the unit is turned off.)

Automatic Shut-OFF function

When the unit is left for about 10 minutes in the stop or pause mode, this function automatically shuts off the power in order to prevent the batteries, etc. from discharging needlessly.

■ To temporarily stop disc play **A**

Press ►|| during play.
Press again to resume play.

■ To stop play **B**

Press ■/POWER OFF during play.

Stop mode

- Ⓐ Total number of tracks
- Ⓑ Total playing time

■ To turn off the unit **B** (Ⓕ)

Press ■/POWER OFF during stop mode.

Off mode

- The batteries can be used for about 10 months (300 times) if they are used every day. They will need to be replaced if the duration of their operation drops drastically.
- You can operate the unit with the AC adaptor while recharging the batteries, but it will lengthen the recharging time.
- Recharging should be performed at 5°C~40°C.
- While recharging, the AC adaptor and rechargeable batteries may get warm. This is normal.

Using the dry cell batteries (not included)

Disconnect the AC adaptor and then install two LR6 (UM-3) type alkaline batteries.

The batteries are inserted and removed in the same way as for the rechargeable batteries.

Using the AC adaptor

Connect the AC adaptor supplied. Refer to the section on "Using the rechargeable batteries" for details on the connections.

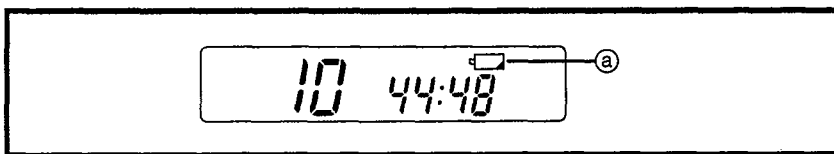

Note

The unit is in the standby condition when the AC adaptor is connected. The primary circuit is always "live" as long as the AC adaptor is connected to an electrical outlet.

Using the car adaptor

Be sure to obtain the car adaptor (SH-CDC9), available as an optional accessory. The batteries can be recharged inside the car using the car adaptor.

Battery indicator

Ⓐ Battery indicator

It starts flashing when the batteries have run down. After a short while the power is automatically cut off.

(The amount of time the unit will continue to play after the indicator has started flashing differs slightly, depending on the type of batteries used.)

Type of battery	Action
Rechargeable batteries	Recharge the batteries again.
Dry cell batteries	Replace with new batteries.

(The battery indicator may not flash if rechargeable batteries, other than those designated by Panasonic, are used.)

Search function

(rapid forward/backward) [A]

Keep depressed <<< or >>> during play.

- During program play, random play or 1-track repeat play, only the track being played is searched.

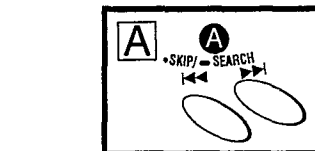

Using the unit with a car audio system

Items to be purchased

- For connection to the car audio system: Car stereo cassette adaptor (SH-CDM9D)
- For securing the unit and connecting the power supply:

- Car adaptor (SH-CDC9)
- Car Mount Kit (SH-CDF7)
- Car mounting arm, Car insulator

Note

It may not be possible to use the unit with some types of car audio systems owing to restrictions imposed by the construction of the car stereo cassette adaptor or Car Mount Kit. For further details, refer to the instructions of the part concerned.

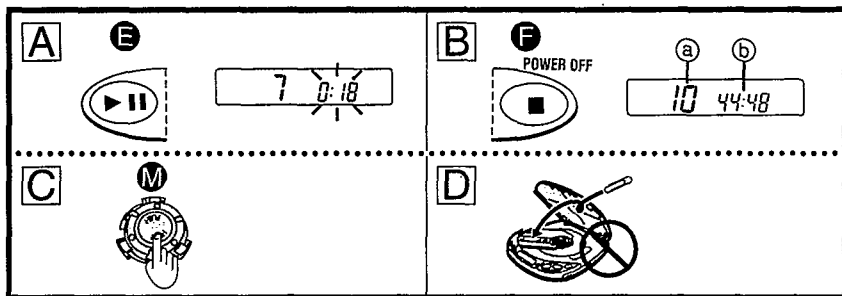

Removing the disc [C]

After the disc has stopped rotating, open lid, press PUSH to release the disc. (Do not open the lid during play.)

Note [D]

Do not put anything inside the unit.

Skip function

(skip forward/backward) [A]

Press <<< or >>> during play.

- During program play the tracks are skipped in the forward or backward direction in the programmed sequence.
- During random play, it is not possible to skip to the track which has already been played.

USING THE UNIT WITH OPTIONAL ACCESSORIES

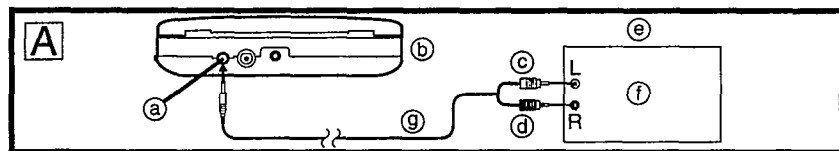

Using the unit with an audio system [A]

Using the stereo connection cable (not included), you can hear CDs on your audio system.

- Connect the cable to the amplifier after turning off its power.
- Do not connect the cable to the PHONO jacks on the amplifier.
- Obtain the optional connecting cable if the amplifier comes with mini-phone jacks.
- Adjust the volume level on the amplifier.

- Ⓐ OUT jack
- Ⓑ Back panel of the unit
- Ⓒ (White)
- Ⓓ (Red)
- Ⓔ Amplifier
- Ⓘ To CD or AUX terminals
- Ⓙ Stereo connection cable

CAUTIONS

AC adaptor

- Handle the AC adaptor carefully. Improper handling is dangerous.
 - Do not touch it with wet hands.
 - Do not place heavy objects on top of it.
 - Do not forcibly bend it.
- Be sure to connect only the AC adaptor provided with the unit.
- Disconnect the AC adaptor from the power outlet if the unit is not going to be used for a long time.

Unit

No altering or remodeling

This can cause malfunctioning.

No dropping or strong impacts

This may damage the unit.

Locations to be avoided

Avoid using the unit in the following locations since they can cause malfunctioning.

1. Bathrooms and other moisture-prone places
2. Warehouses and other dusty places
3. Very hot places near heating appliances, etc.

When driving a car

For safety reasons, do not operate the unit while driving.

Precautions for Listening with the Headphones

- Do not play your headset at a high volume. Hearing experts advise against continuous extended play.
- If you experience a ringing in your ears, reduce volume or discontinue use.
- Do not use while operating a motorized vehicle. It may create a traffic hazard and is illegal in many areas.
- You should use extreme caution or temporarily discontinue use in potentially hazardous situations.

Do not leave the unit exposed to direct sunlight for long periods of time.

This may deform or discolor the cabinet and may also cause malfunctioning.

Rechargeable batteries

- Only the RP-BP60 (SH-CDB8D) batteries can be recharged.
- If the power delivered by the batteries lasts for a very short time after recharging, it means that the batteries' service life is over. Do not use them any more, please replace the batteries.
- Recharging already charged batteries will shorten their service life.
- When recharging batteries for the first time or when they have not been used for a long period of time, the play time may be shorter than usual. In a case like this, repeatedly recharge and discharge the batteries. This will restore them to their regular charged state.
- Do not allow any metal objects to touch the terminals of rechargeable batteries since this may cause short-circuiting which is dangerous.
- Do not peel off the plastic covering on the rechargeable batteries. Short-circuiting may occur, which is dangerous.

- Even if your headset is an open-air type designed to let you hear outside sounds, don't turn up the volume so high that you can't hear what's around you.

When purchasing rechargeable batteries [A]

As a safety precaution, the portable CD players made by our company have a construction designed to make it impossible to recharge ordinary batteries.

To use rechargeable batteries, be absolutely sure to purchase the rechargeable Ni-Cd batteries designed especially for this unit.

Special rechargeable Ni-Cd batteries: SH-CDB8D (set of 2)

For details, check with your dealer.

- Ⓐ Special rechargeable batteries
- Ⓑ Ordinary dry cell batteries/rechargeable batteries

Dry cell batteries/rechargeable batteries

To prevent damage to the batteries and electrolyte leakage, heed the following points into the unit.

- Align the ⊕ and ⊖ polarities properly when inserting the batteries.
- Do not mix different types or makes of batteries or old and new batteries.
- Remove the batteries if you do not plan to use the unit for an extended period of time.
- Do not throw batteries into a fire, and do not short-circuit, disassemble or subject them to excessive heat.
- Do not attempt to recharge dry cell batteries.

Carrying dry cell batteries or rechargeable batteries around

When putting dry cell or rechargeable batteries in a pocket or bag, ensure that no other metal objects, such as a necklace, are placed in the pocket or bag with them. Contact with metal may cause short-circuiting which, in turn, may cause a fire.

Be absolutely sure to carry the rechargeable batteries in the battery carrying case.

[For (E, EB) areas.]

Notice about the rechargeable battery
The battery is designated recyclable.
Please follow your local recycling regulations.

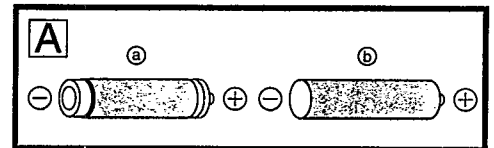

HANDLING PRECAUTIONS FOR TRAVERSE DECK

The laser diode in the traverse deck (optical pickup) may break down due to potential difference caused by static electricity of clothes or human body.

So, be careful of electrostatic breakdown during repair of the traverse deck (optical pickup).

Handling of traverse deck (optical pickup)

1. Do not subject the traverse deck (optical pickup) to static electricity as it is extremely sensitive to electrical shock.
2. The short land between the No. ④ (LD) and No. ⑤ (GND) pins on the flexible board (FFC) is shorted with a solder build-up to prevent damage to the laser diode.
To connect to the PC board, be sure to open by removing the solder build-up, and finish the work quickly.
3. Take care not to apply excessive stress to the flexible board (FFC).
4. Do not turn the variable resistor (laser power adjustment). It has already been adjusted.

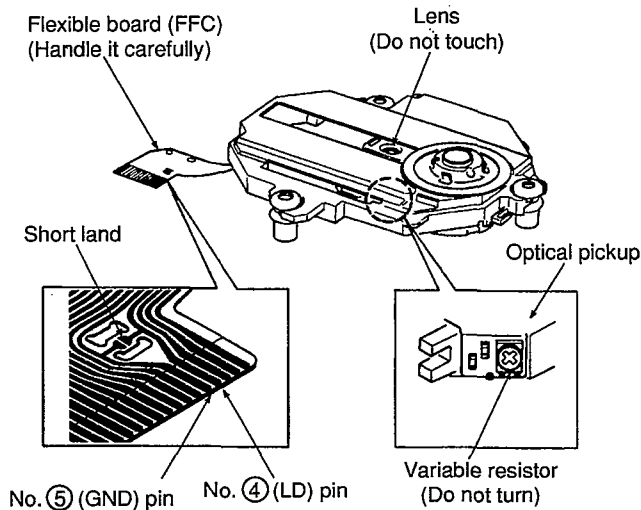

Grounding for electrostatic breakdown prevention

1. Human body grounding
Use the anti-static wrist strap to discharge the static electricity from your body.
2. Work table grounding
Put a conductive material (sheet) or steel sheet on the area where the optical pickup is placed, and ground the sheet.

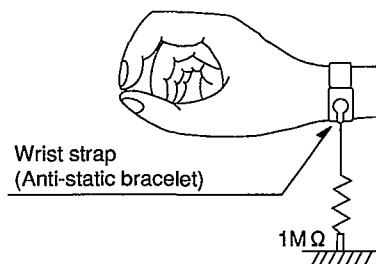

Caution:

The static electricity of your clothes will not be grounded through the wrist strap. So, take care not to let your clothes touch the traverse deck (optical pickup).

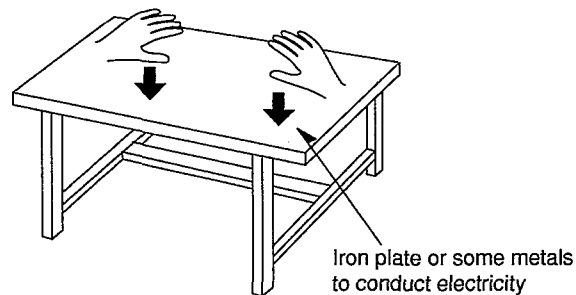

OPERATION CHECKS AND MAIN COMPONENT REPLACEMENT PROCEDURES

Warning: This product uses a laser diode. Refer to caution statements on page 2.

ACHTUNG: • Die lasereinheit nicht zerlegen.

• Die lasereinheit darf nur gegen eine vom hersteller speziferte einheit ausgetauscht werden.

- NOTE**
1. This section describes procedures for checking the operation of the major printed circuit boards and replacing the main components.
 2. For reassembly after operation checks or replacement, reverse the respective procedures. Special reassembly procedures are described only when required.
 3. Illustrated screws are equivalent to actual size.
 4. [] indicates parts No.

1. Checking for the P.C.B.

Step 3

Lift up the intermediate cabinet ass'y

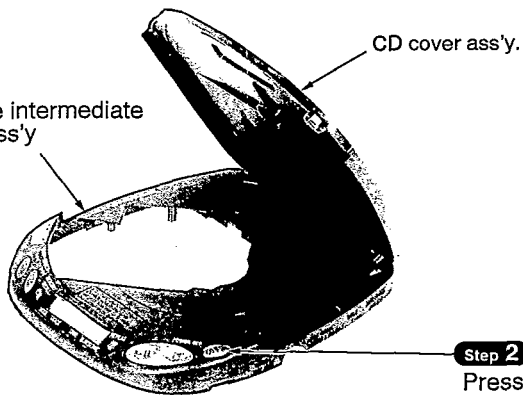

Step 2

Pressing the OPEN button, open the CD cover ass'y.

Step 4

Remove the 4 switch knobs.

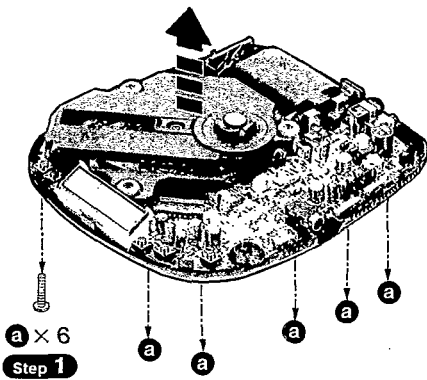

(Black)

(Silver)

Step 5

Remove the traverse deck and P.C.B..

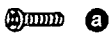
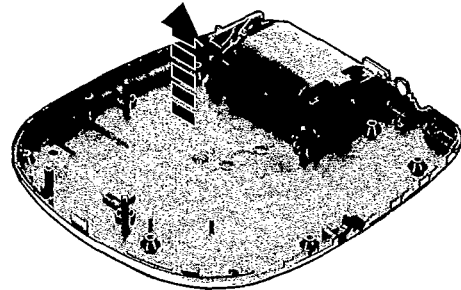

[XTN17+6GFZ] (Black)

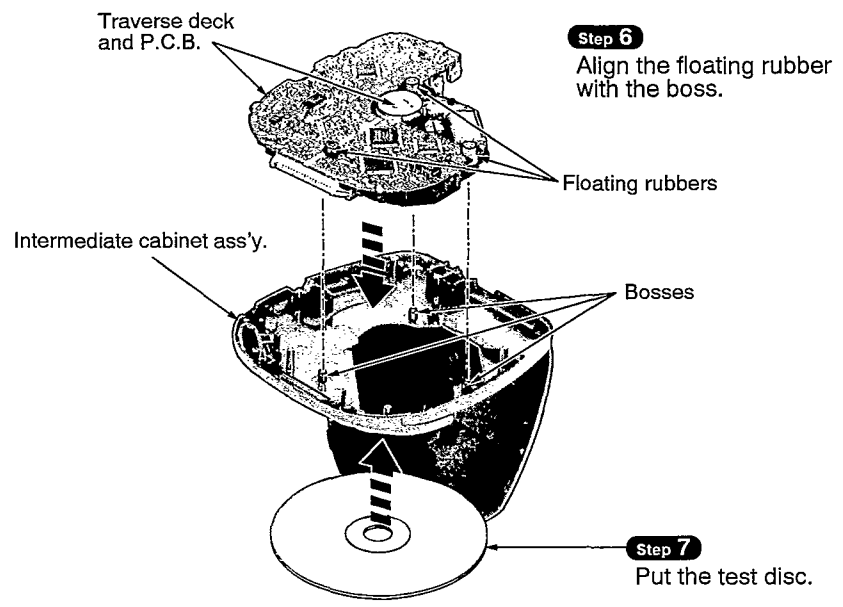

Step 6
Align the floating rubber with the boss.

Step 7
Put the test disc.

• Check the P.C.B. (Solder side) as shown below.

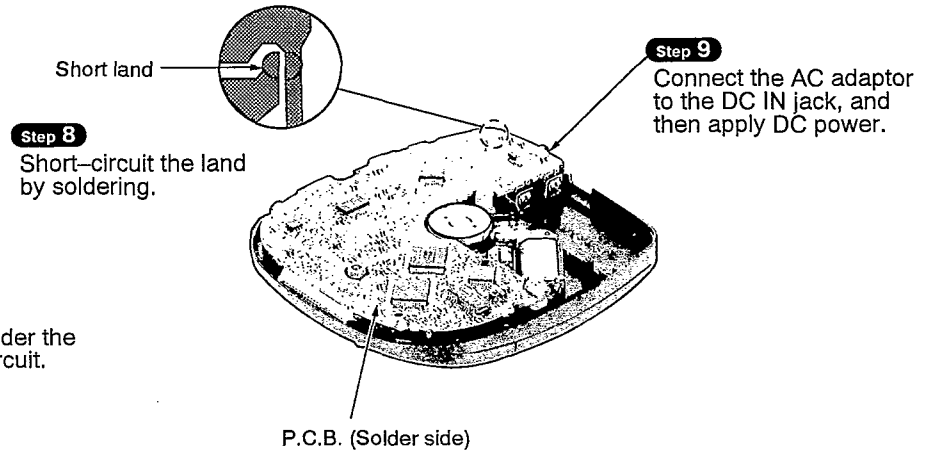

Step 8
Short-circuit the land by soldering.

Step 9
Connect the AC adaptor to the DC IN jack, and then apply DC power.

NOTE
After checking, unsolder the short land to open circuit.

2. Replacement for the traverse deck

• Follow the **Step 1** ~ **Step 3** in item 1.

NOTE
Solder the point between pin 4 (LD) and pin 5 (GND) of FFC board.
(Refer to "Handling Precautions for Traverse Deck" on page 7.)

Step 1
Pull out the traverse deck in the direction of arrow.

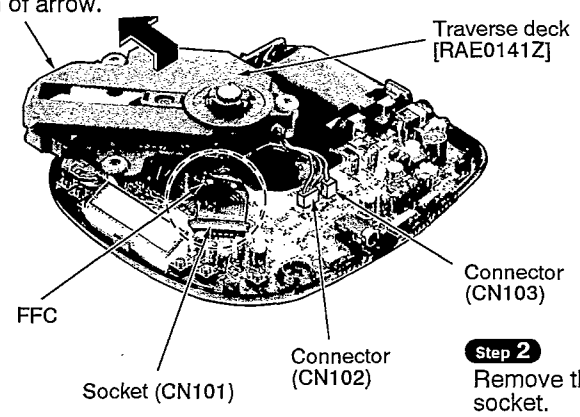
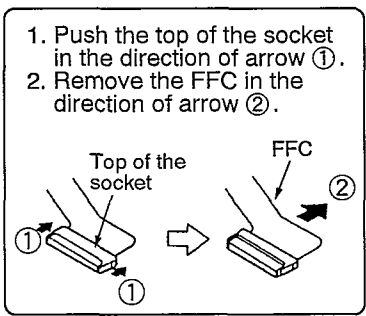

Step 2
Remove the 2 connectors and socket.

3. Replacement for the CD cover ass'y

• Follow the **Step 1** ~ **Step 3** in item 1.

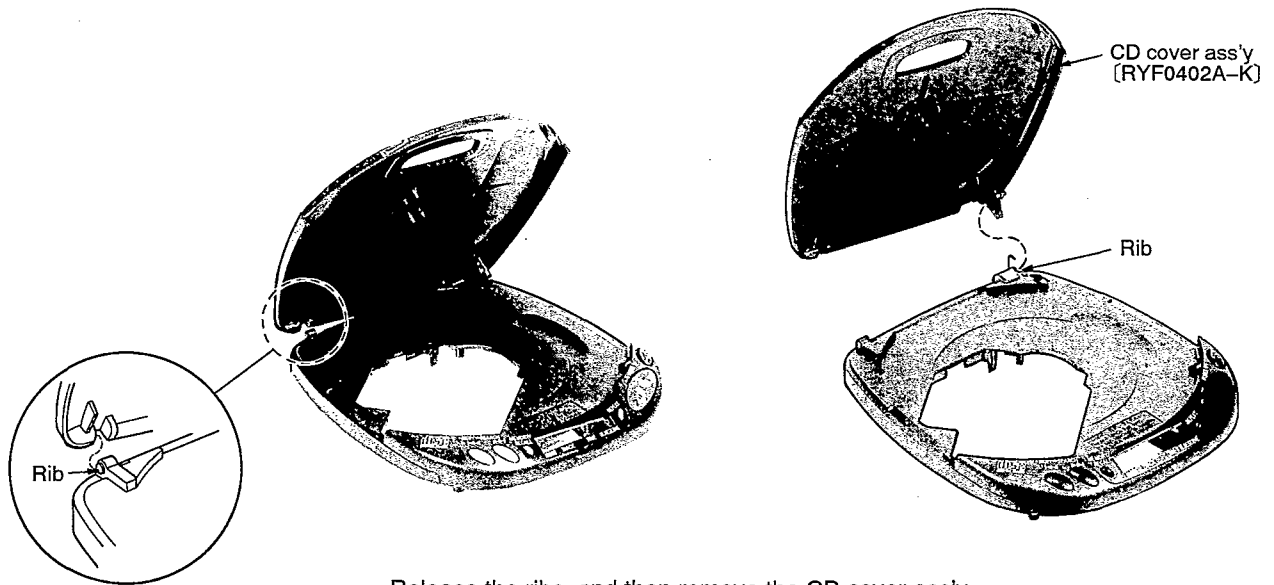

• Release the ribs, and then remove the CD cover ass'y.

• Terminal guide of IC's, transistors and diodes

<table border="1"> <tr> <td>NJU7082AMTE1</td> <td>8PIN</td> </tr> <tr> <td>AN8837SBE1</td> <td>28PIN</td> </tr> </table>	NJU7082AMTE1	8PIN	AN8837SBE1	28PIN	<table border="1"> <tr> <td>AN8788FB</td> <td>44PIN</td> </tr> <tr> <td>SM5856A1F</td> <td>44PIN</td> </tr> <tr> <td>MN662745RPC</td> <td>80PIN</td> </tr> </table>	AN8788FB	44PIN	SM5856A1F	44PIN	MN662745RPC	80PIN	<p>SC440301FU</p>	<p>LH6456K2</p>
NJU7082AMTE1	8PIN												
AN8837SBE1	28PIN												
AN8788FB	44PIN												
SM5856A1F	44PIN												
MN662745RPC	80PIN												
<p>FMW1T98 FMG4T148</p>	<p>2SD1450STTA</p>	<p>2SB709QRSTX</p>	<p>2SD2074HWRST</p>	<p>MA151WKTX</p>									
<p>MA8047MTX MA8051MTX</p>	<p>1SS355TE17</p>	<p>SS14G11</p>											

■ CHECKING THE OPERATION PROBLEMS ON THE TRAVERSE DECK (OPTICAL PICKUP)

Make sure to follow the procedures below to check the operation problems of the traverse deck (optical pickup) before replacing it. Replace the traverse deck only after the problem is identified.

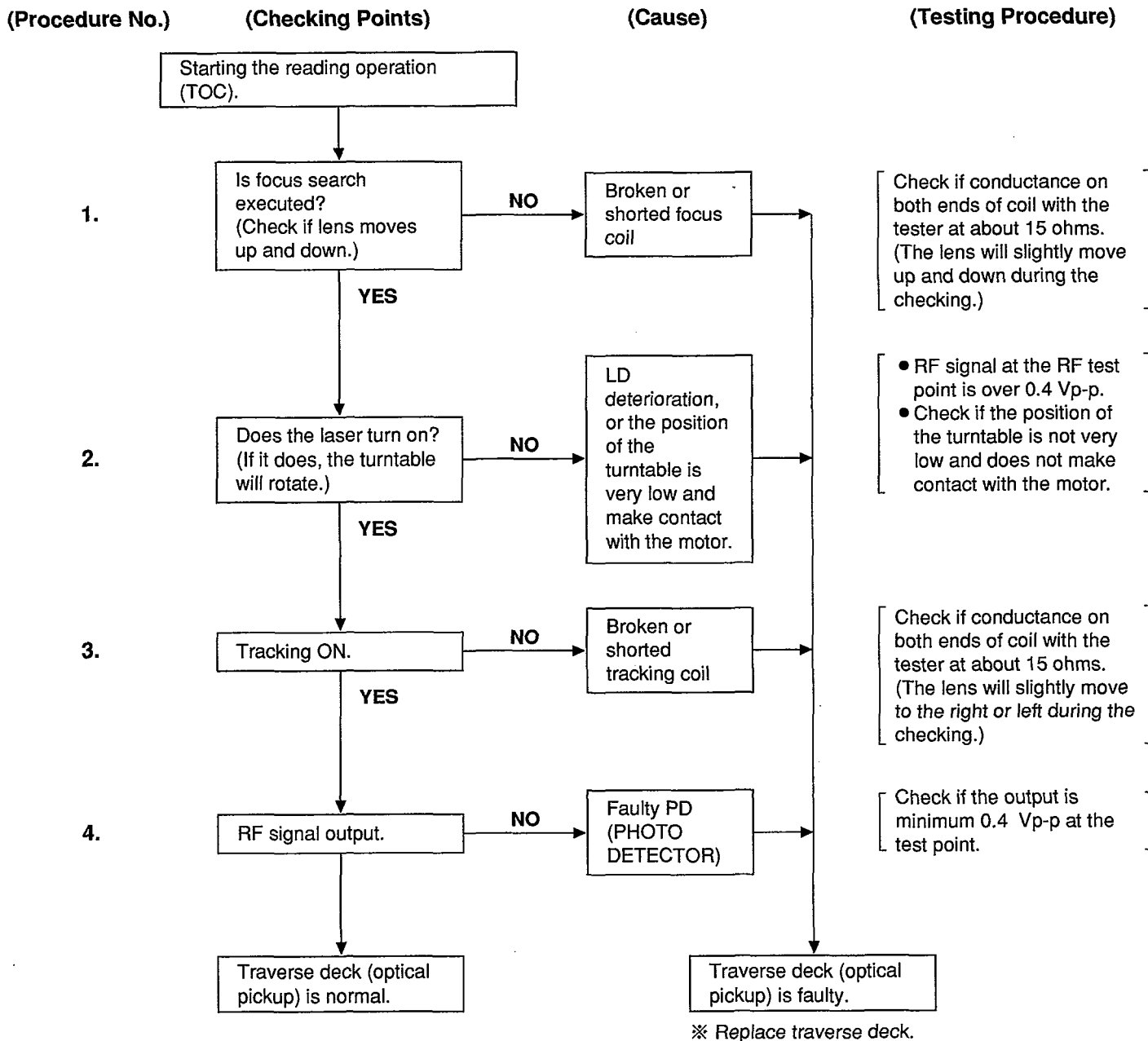

- Check electrical circuit.
- Check for flaws on disc or if it is warped or not centered.

• Check the operations described below on the traverse deck after replacing it.

* Checking Skip Search

1. Play an ordinary musical program disc.
2. Press the skip button to check for normal skip search operation (in both the forward and reverse directions).

* Checking Manual Search

1. Play an ordinary musical program disc.
2. Press the manual search button to check for smooth manual search operations at either low or high speed (in both the forward and reverse directions).

* Checking Playability

1. Play the 0.7 mm black dot and the 0.7 mm wedge on the playability test disc (SZZP1054C) and verify that no sound skip or noise occurs.
2. Play the middle tracks of the uneven test disc (SZZP1056C) and verify that no sound skip or noise occurs.

■ AUTOMATIC ADJUSTMENT RESULTS DISPLAY FUNCTION (SELF-CHECK FUNCTION)

On this unit (SL-XP240), each automatic adjustment result are displayed on the LCD. This function is convenient to check or identify which automatic adjustment circuit is incorrect. The followings are the contents of the automatic adjustment result displays (self-check function).

● How to display automatic adjustment results

1. Load the test disc (SZZP1054C).
2. Press the ◀◀ (SKIP/SEARCH) and ▶▶ (SKIP/SEARCH) Buttons simultaneously and hold them, and additionally press the ▶ / || (PLAY/PAUSE) Button.
3. Press the ■ (STOP/POWER OFF) Button once.
4. An automatic adjustment result is displayed on the LCD.

● Display of automatic adjustment results (self-check function)

LCD Display

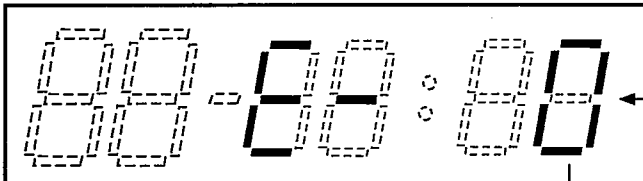

MSB LSB

TGC	FGC	TBC	FBC
-----	-----	-----	-----

(Each bit ... TGC, FGC, TBC, FBC)
 0 ... OK
 1 ... NG

⟨Example⟩

1)	0	0	0	0	⇒	“E-0” is displayed. (All adjustments are OK.) Normal
2)	0	0	0	1	⇒	“E-1” is displayed. (OK) (OK) (OK) (NG) (Focus balance adjustment is NG (incorrect.))
3)	0	1	0	0	⇒	“E-4” is displayed. (OK) (NG) (OK) (OK) (Focus gain adjustment is NG.)
4)	1	1	1	1	⇒	“E-F” is displayed. (All adjustments are NG.)
5)	1	0	0	0	⇒	“E-8” is displayed. (NG) (OK) (OK) (OK) (Tracking gain adjustment is NG.)

Note: If any other disc than the test disc (SZZP1054C) is used, an “E-8” may be displayed.

〈Example〉 Follow the below steps when “E—1” is displayed.

(Cause: Focus balance (FBC) is set beyond the limit.)

• Check if

- (1) the waveform or voltage of the focus servo circuit is correct, and
- (2) the optical pickup returns to the normal state by exchanging the traverse deck.

Follow the below steps when “E—4” is displayed.

(Cause: Focus gain (FGC) is set beyond the limit.)

• Check if

- (1) the waveform or voltage of the focus servo circuit is correct,
- (2) the focus coil of the optical pickup is correct (around 15 ohms), and
- (3) the optical pickup returns to the normal state by exchanging the traverse deck.

Follow the below steps when “E—F” is displayed.

(Cause : All adjustments (TGC, FGC, TBC, FBC) are set beyond the limit.)

• Check if

- (1) the optical pickup returns to the normal state by exchanging the traverse deck, and
- (2) the waveform or voltage of the servo IC's (IC101, 501) are correct.

Note:

It is not always necessary to exchange the traverse deck when an error message is displayed. Be sure to check if the circuit is defective or not before exchanging the traverse deck.

Note:

If any other disc than the test disc (SZZP1054C) is used, an error message may be displayed. This is not a malfunction.

MEASUREMENTS AND ADJUSTMENTS

Warning: This product uses a laser diode. Refer to caution statements on page 2.

ACHTUNG: • Die lasereinheit nicht zerlegen.

- Die lasereinheit darf nur gegen eine vom hersteller spezifizierte einheit ausgetauscht werden.

• Measuring instruments and special tools

• Test discs

1. Playability test disc (SZZP1054C)
2. Uneven test disc (SZZP1056C)

• Musical program disc (ordinary)

- DC voltmeter
- Lead wire (for test points)

• Test short land

Short-circuit the lands of the laser ON/OFF switch (S201) by soldering them. It turns “ON” position. (Refer to below Fig. 1 or printed circuit board and wiring connection diagram for short land location on page 25.)

Note: Remove the solders from the lands after adjustment.

• Adjustment point

- Notes:** 1. Please refer to the printed circuit board and wiring connection diagram for test point locations.
2. Take care to connect CN101, as shown in Fig. 1.

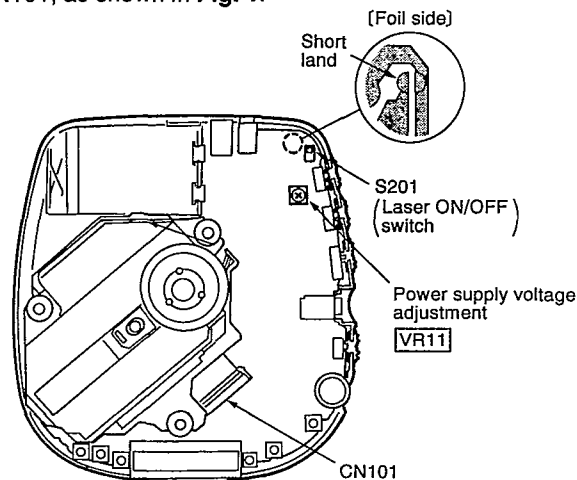

Fig. 1

● Adjustment procedure

(1) POWER SUPPLY VOLTAGE ADJUSTMENT

1. Connect the DC voltmeter to **TP2** (VCC) (+) and **TP3** (GND) on the P.C.B.
2. Connect the AC adaptor cord to the DC (IN) port and move the PLAY switch to the ON position.
(Use a new dry cell battery or a rechargeable battery that is full charged.)
3. Insert the test disc, and switch the player power ON.
4. Adjust **VR11** on the P.C.B. at 3.32 ± 0.02 V, as shown in **Fig. 1**.

(2) CHECK OF PLAY OPERATION

*Checking Skip Search

1. Play an ordinary musical program disc.
2. Press the skip button to check for normal skip search operation (in both the forward and backward directions).

*Checking Manual Search

1. Play an ordinary musical program disc.
2. Press the manual search button to check for smooth manual search operations at either low or high speed (in both the forward and backward directions).

*Checking Playability

1. Play the 0.7 mm black dot and the 0.7 mm wedge on the playability test disc (SZZP1054C) and verify that no sound skip or noise occurs.
2. Play the middle tracks of the uneven test disc (SZZP1056C) and verify that no sound skip or noise occurs.

● Automatic adjustment

On our conventional type portable CD player, there were mounted 6 semi-fixed controls for each adjustment. Since the SL-XP240 servo circuit is equipped with an automatic adjusting circuit, these controls are removed from SL-XP240.

On conventional portable CD player

Use for Old Servo IC (AN8373SE2, AN8374SE2)

1. Tracking Offset Adjustment VR (TOC)
2. Focus Offset Adjustment VR (FOC)
3. Tracking Gain Adjustment VR (TGC)
4. Focus Gain Adjustment VR (FGC)
5. Tracking Balance Adjustment VR (TBC)
6. Focus Balance Adjustment VR (FBC)

On SL-XP240

Use for New Servo IC (AN8837SBE1, MN662745RPC)

- ➔ Non Adjustment
- ➔ Automatic Adjusting Circuit

Total 6 Adjustment VRs

➔ No Adjustment VR

Although all discs are manufactured according to the same specifications, their characteristics are not always precisely the same because they are produced by different manufacturers in various lots, or have different warp etc. SL-XP240 automatically controls the servo circuit to obtain optimum performance according to any disc's characteristics. Therefore, no malfunction occurs because of mis-adjustment.

BLOCK DIAGRAM

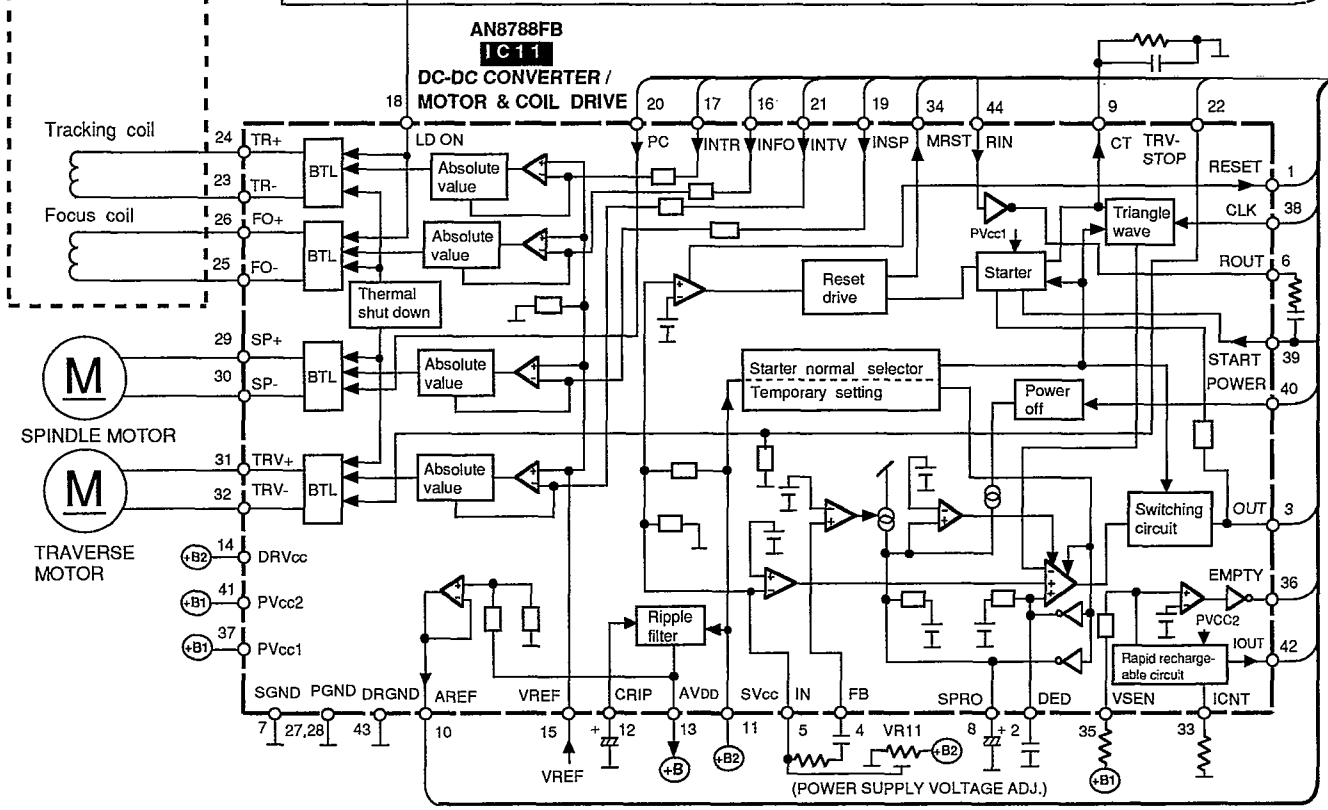
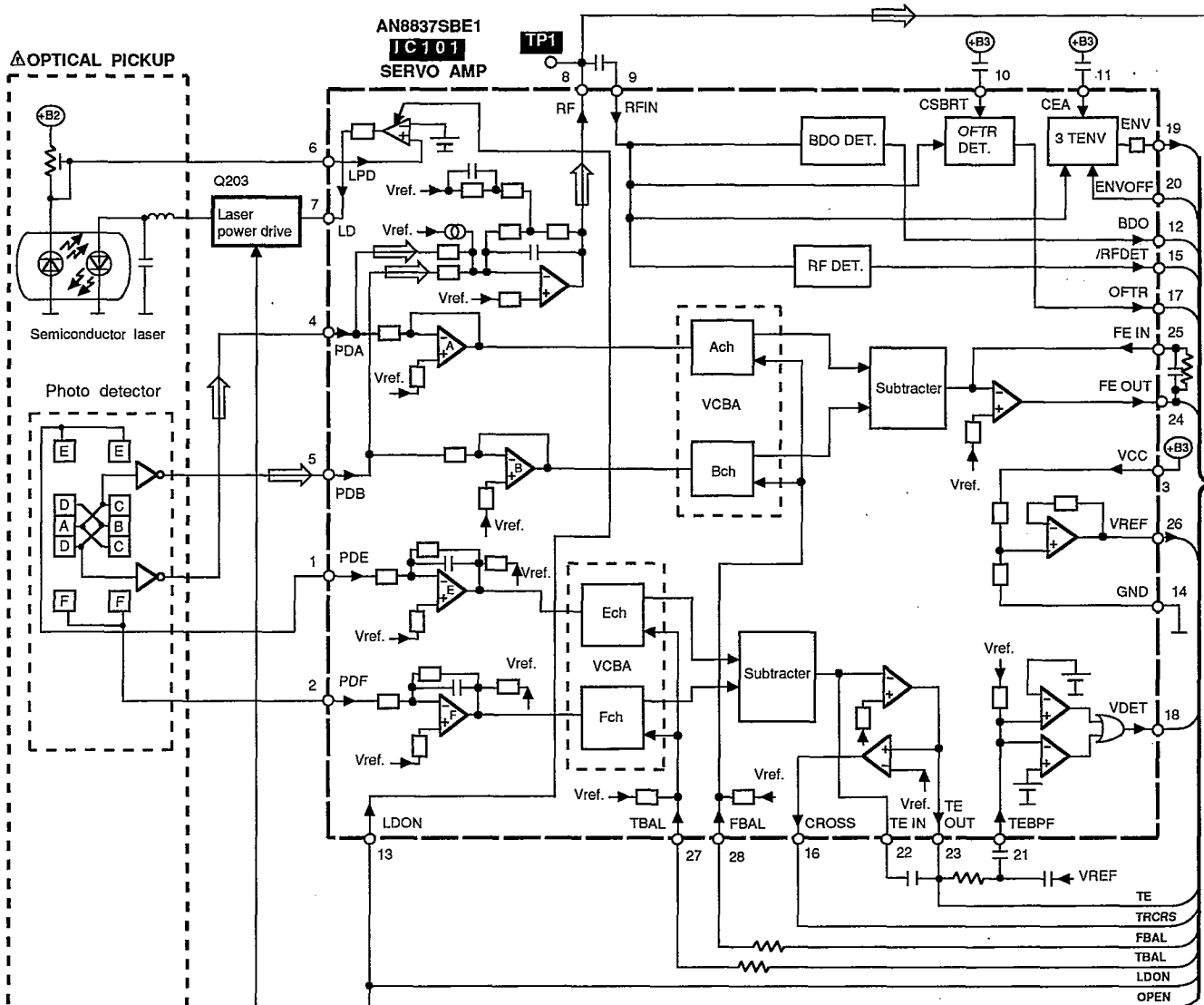

● Signal line ➡ : Audio signal

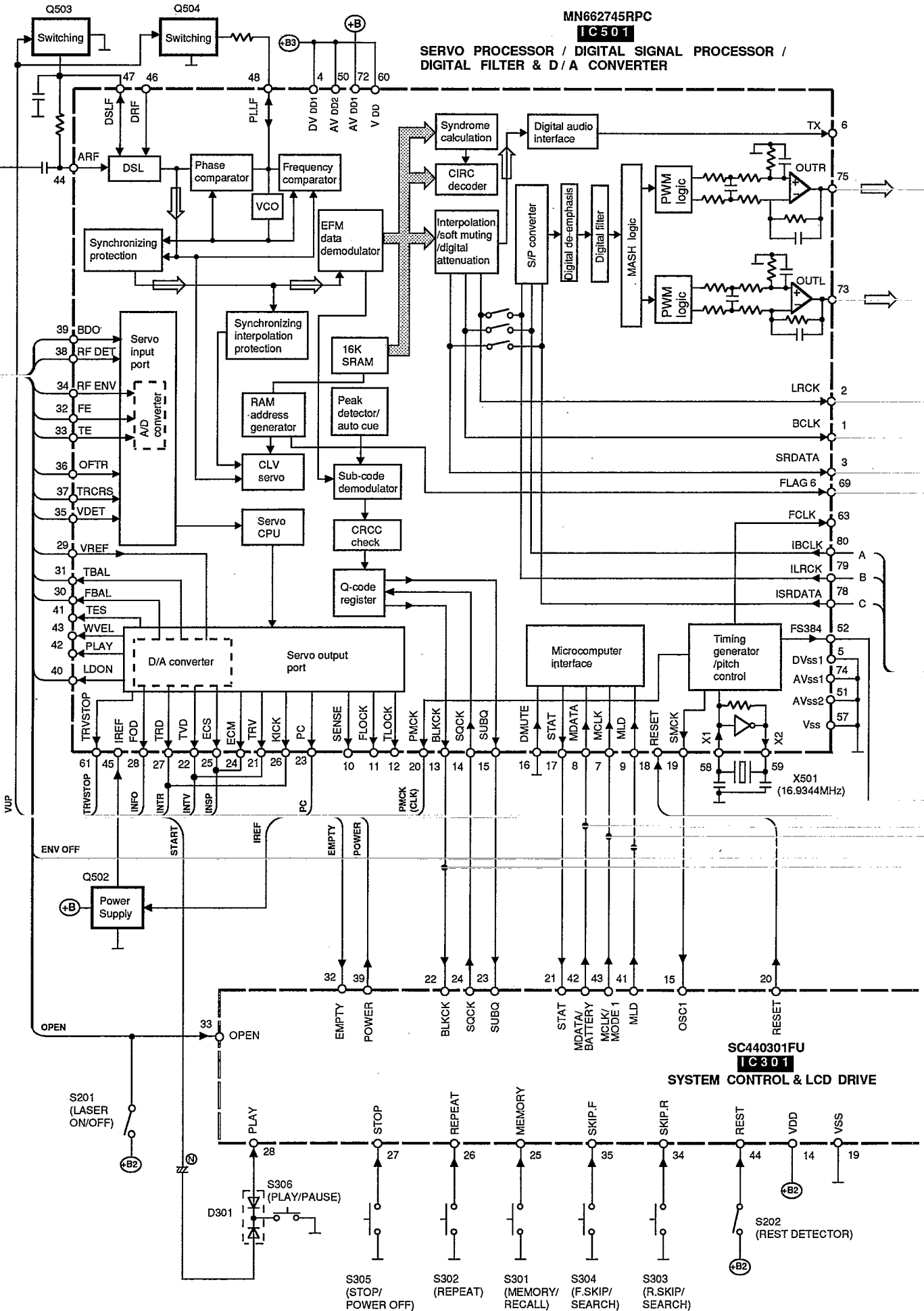

• Signal line \Rightarrow : Audio signal

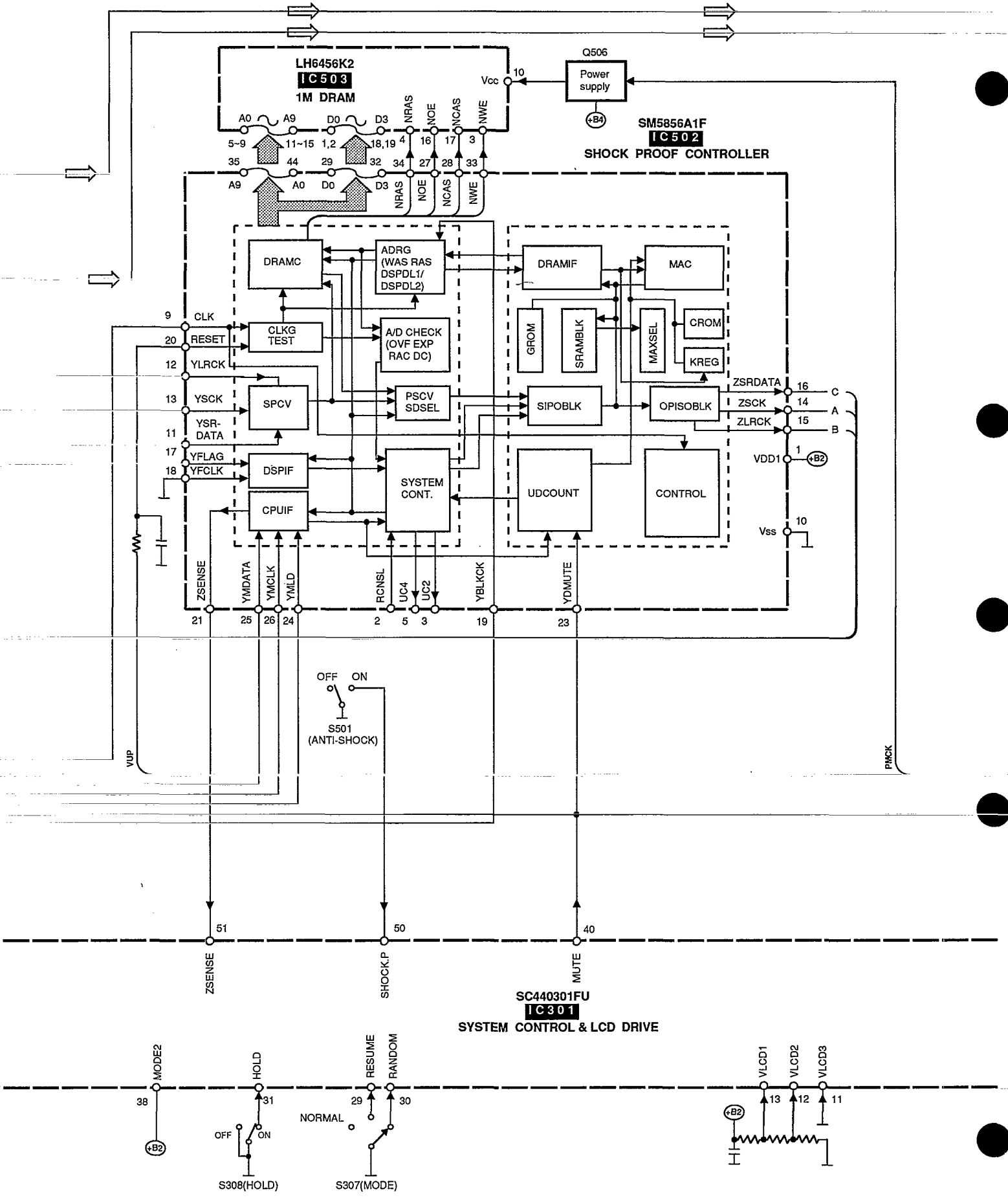

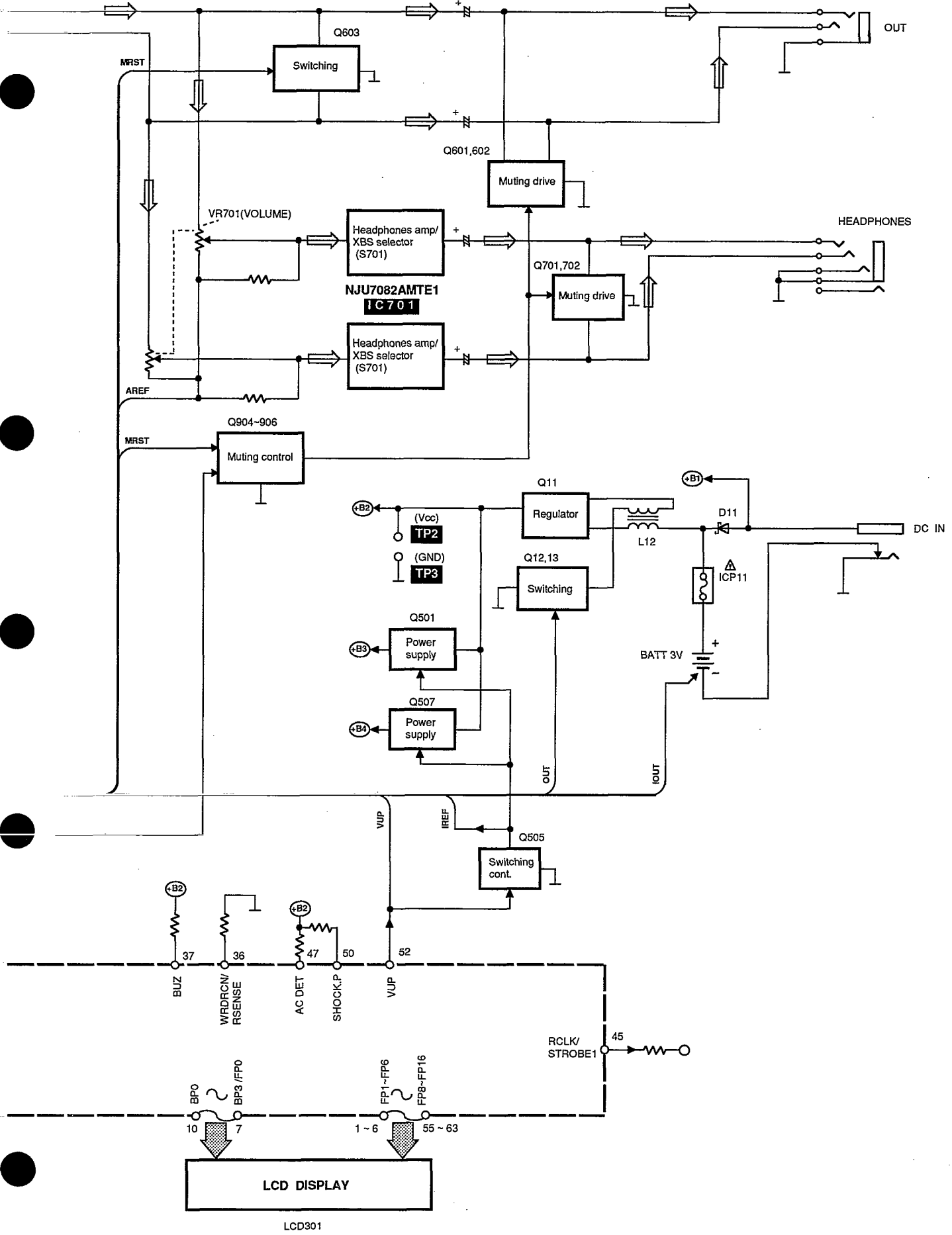

■ SCHEMATIC DIAGRAM (See parts list on pages 32, 34,35,36.)

(This schematic diagram may be modified at any time with the development of new technology.)

Notes:

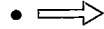
- **S201:** Laser ON/OFF switch in "OFF" position.
(It turns "ON" with disc holder closed.)
- **S202:** Rest detector in "OFF" position.
(It turns "ON" when optical pickup comes to innermost periphery.)
- **S301:** Memory/recall (MEMORY/RECALL) switch.
- **S302:** Repeat (REPEAT) switch.
- **S303, 304:** Skip/search (◀◀-SKIP/--SEARCH▶▶) switches.
(S303: ▶▶, S304: ◀◀)
- **S305:** Stop/power off (■ POWER OFF) switch.
- **S306:** Play/pause (▶ ||) switch.
- **S307:** Play mode selector (MODE) in "RANDOM" position.
(RANDOM↔NORMAL↔RESUME)
- **S308:** Hold (HOLD) switch in "ON" position.
- **S501:** Anti-shock switch in "ON" position.
- **S701:** XBS selector in "ON" position.
- The voltage value and waveforms are the reference voltage of this measured by DC electronic voltmeter (high impedance) and oscilloscope on the basis of GND terminal (DC IN Jack). Accordingly, there may arise some errors in the voltage values and waveforms depending upon the internal impedance of the tester or measuring unit.
* The parenthesized is the voltage for test disc (1 kHz, L+R, 0 dB) in play mode, and the other, for no disc in stop mode.
* AC adaptor is used for power supply.
-  : Positive voltage lines.
-  : Audio signal lines.
- Important safety notice:
Components identified by Δ mark have special characteristics important for safety. Furthermore, special parts which have purposes of fire-retardant (resistors), high-quality sound (capacitors), low-noise (resistors), etc. are used. When replacing any of components, be sure to use only manufacture's specified parts shown in the parts list.
- ※ marks indicate printed resistor.

Caution!

- IC and LSI are sensitive to static electricity.
Secondary trouble can be prevented by taking care during repair.
- Cover the parts boxes made of plastics with aluminum foil.
 - Ground the soldering iron.
 - Put a conductive mat on the work table.
 - Do not touch the pins of IC or LSI with fingers directly.

(P.C.Board: on page 25)

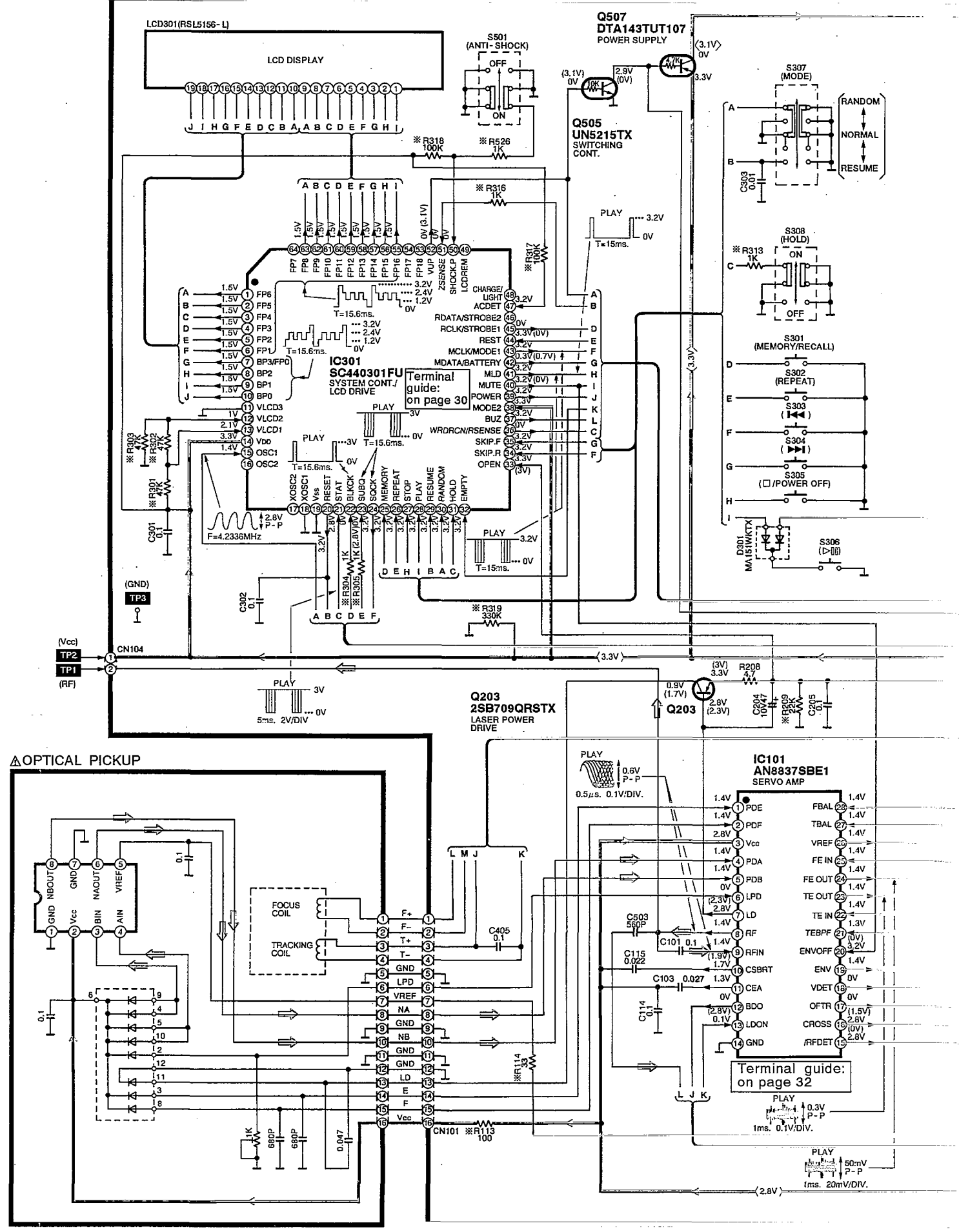

• → : Audio signal lines.

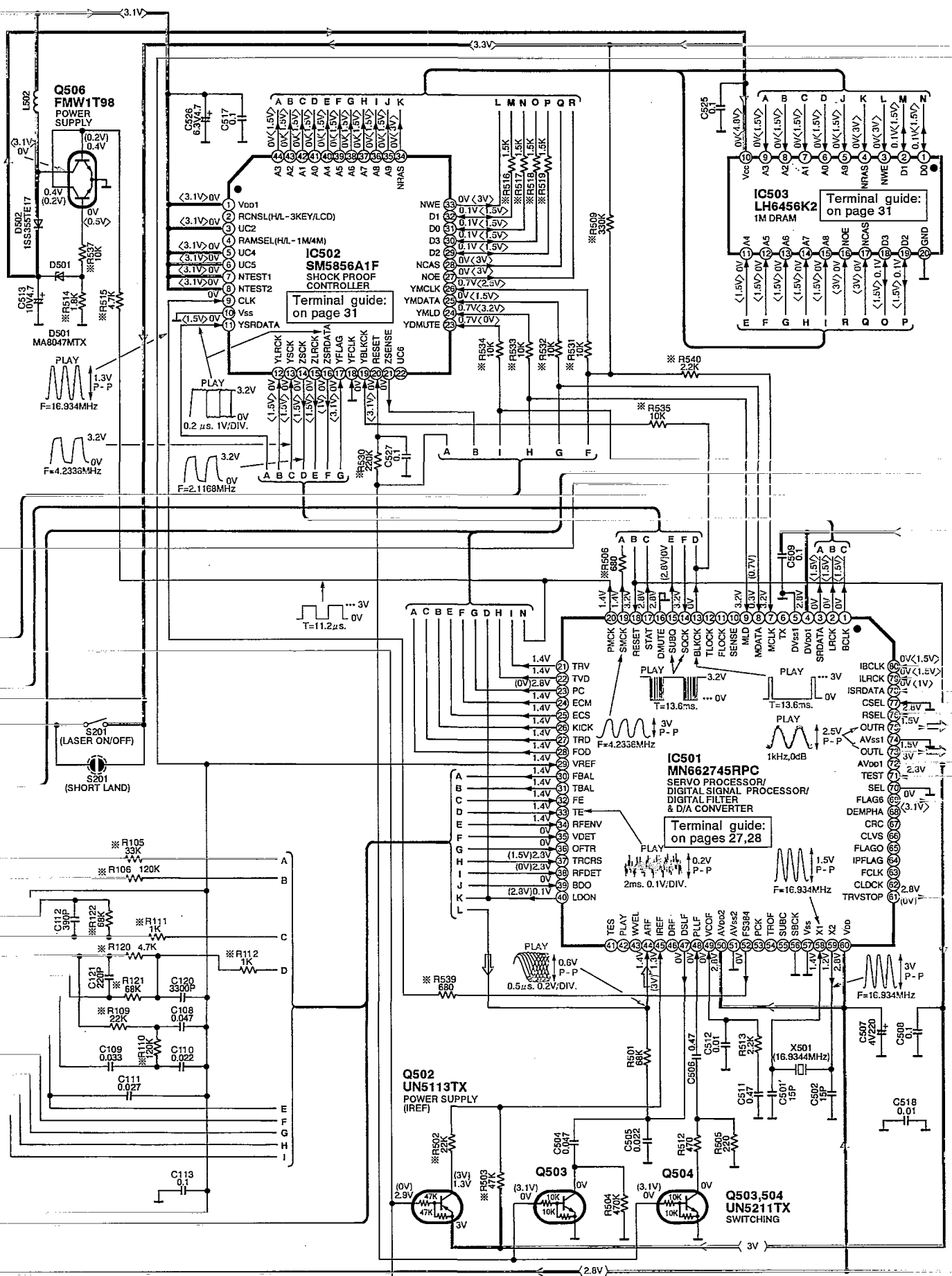

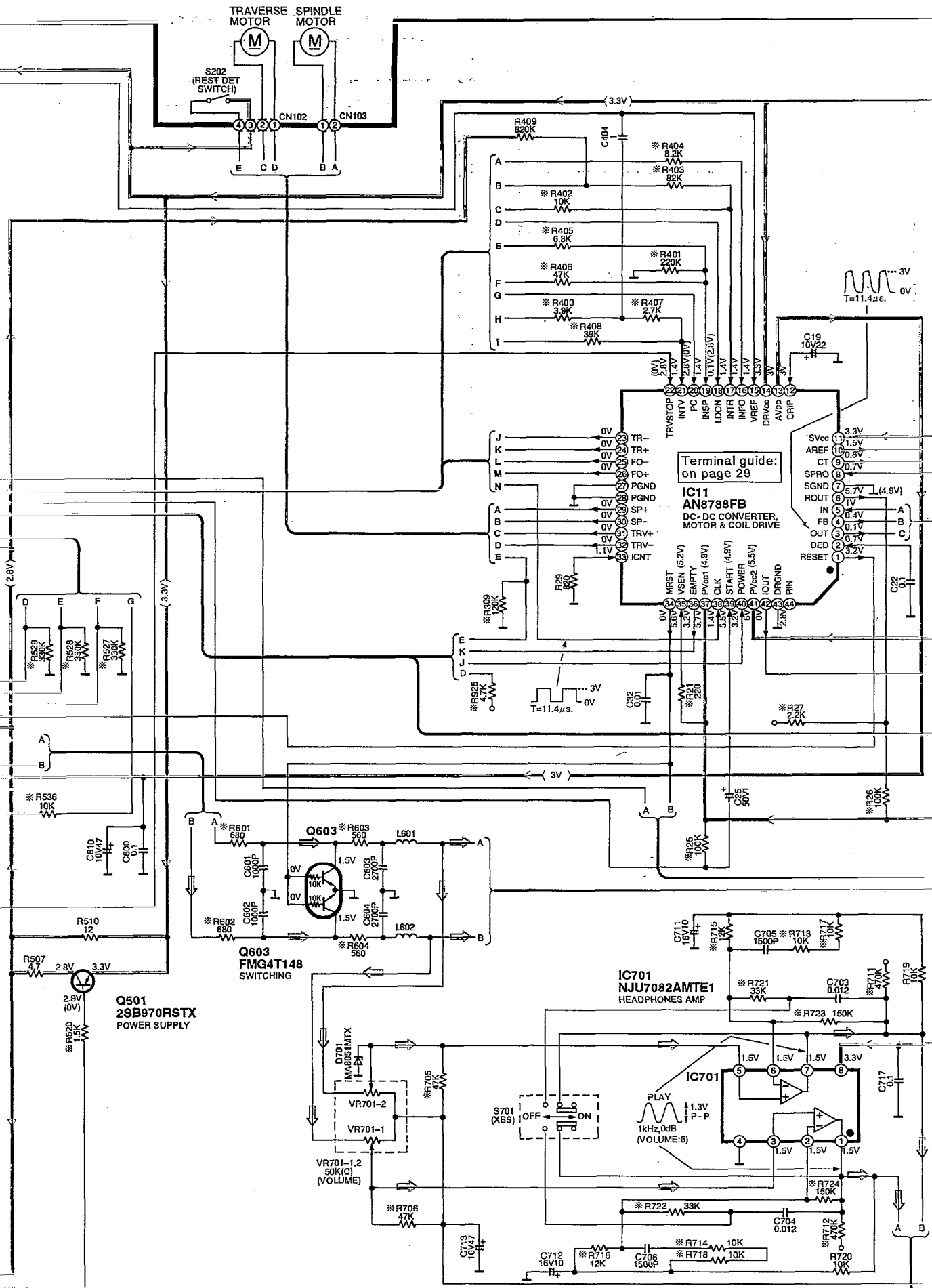

● → : Audio signal lines.

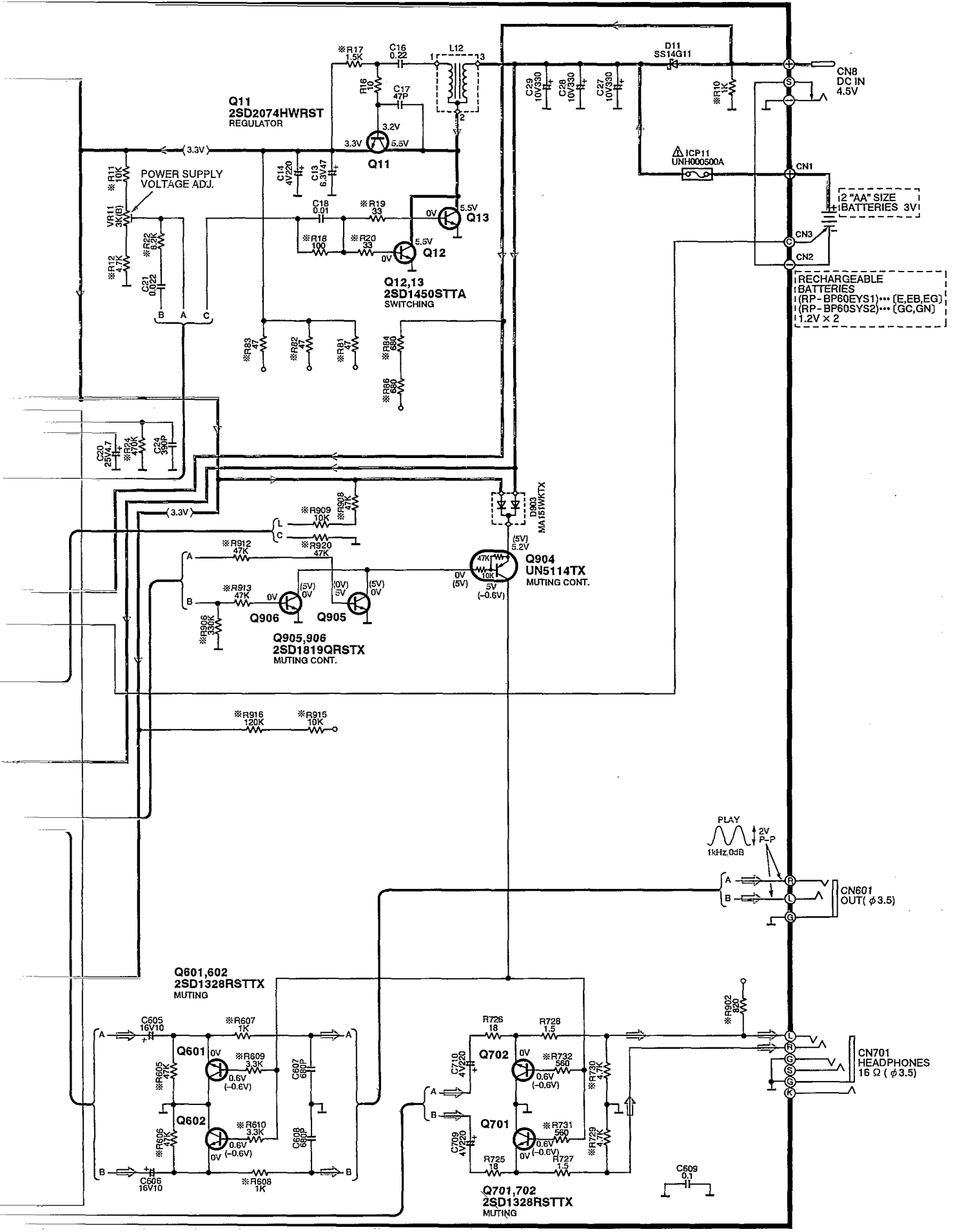

PRINTED CIRCUIT BOARD AND WIRING CONNECTION DIAGRAM

Notes:

- In this printed circuit board diagram, the parts and foil patterns on the board facing toward you are printed in black. The opposite side is printed in blue.
- The "●" mark denotes the connection points of double-faced foil patterns (through holes) on both sides of the printed circuit board.
- This printed circuit board diagram may be modified at any time with the development of new technology.

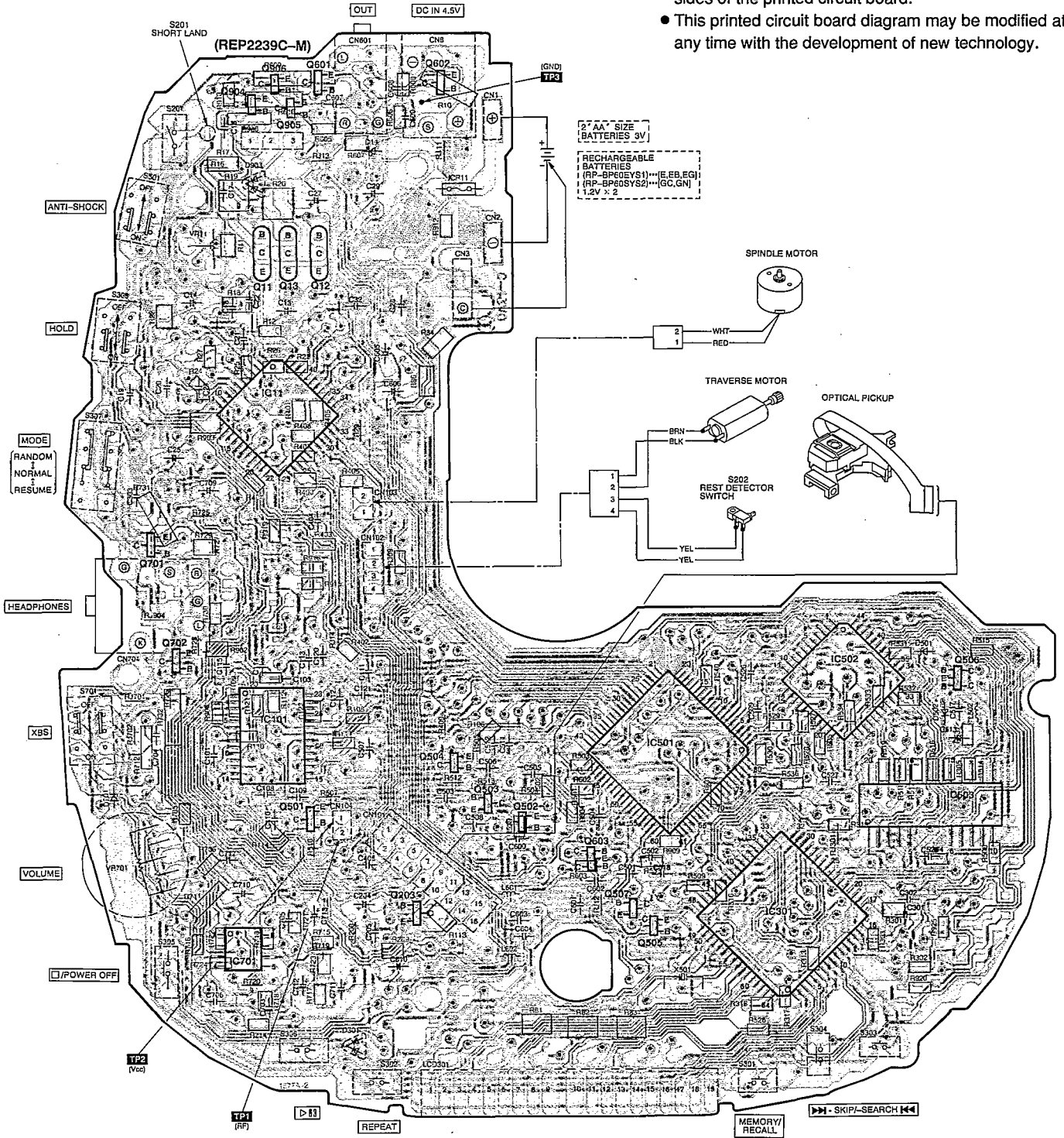

REPAIRING THE PRINTED RESISTOR

This unit uses a printed resistor for the printed circuit board. If the printed resistor is insulated, all maintenance should be done with reference to the following repair parts connection diagram and repair parts list.

Note: Reading the repair parts connection diagram.

- The pattern foil and repair parts are printed in blue.
- The connection points (• \sim •) for the pattern foil and repair parts are printed in black.

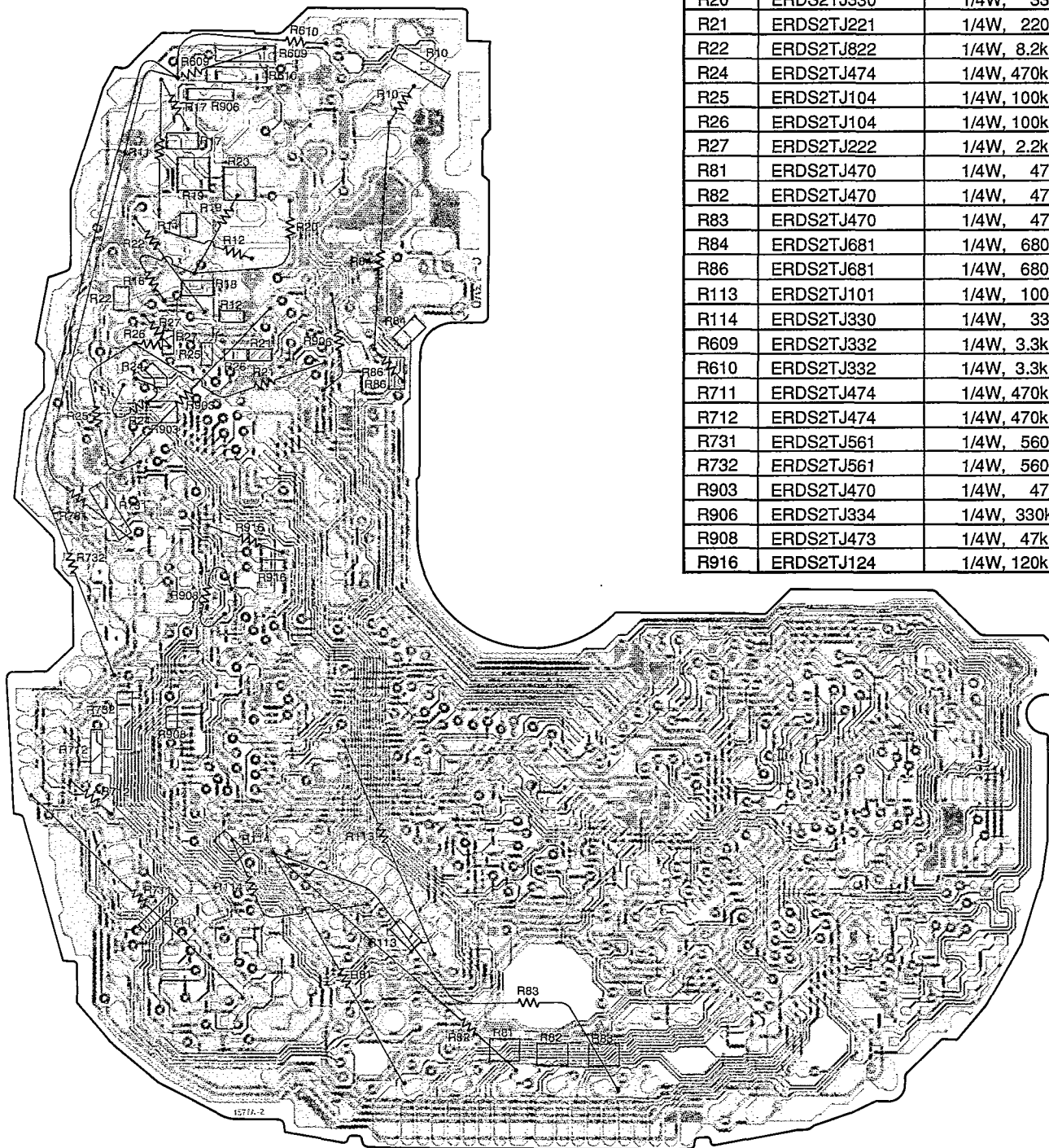

REPLACEMENT PARTS LIST

Ref. No.	Part No.	Values & Remarks
R10	ERDS2TJ102	1/4W, 1k Ω
R11	ERDS2TJ103	1/4W, 10k Ω
R12	ERDS2TJ472	1/4W, 4.7k Ω
R17	ERDS2TJ152	1/4W, 1.5k Ω
R18	ERDS2TJ101	1/4W, 100 Ω
R19	ERDS2TJ330	1/4W, 33 Ω
R20	ERDS2TJ330	1/4W, 33 Ω
R21	ERDS2TJ221	1/4W, 220 Ω
R22	ERDS2TJ822	1/4W, 8.2k Ω
R24	ERDS2TJ474	1/4W, 470k Ω
R25	ERDS2TJ104	1/4W, 100k Ω
R26	ERDS2TJ104	1/4W, 100k Ω
R27	ERDS2TJ222	1/4W, 2.2k Ω
R81	ERDS2TJ470	1/4W, 47 Ω
R82	ERDS2TJ470	1/4W, 47 Ω
R83	ERDS2TJ470	1/4W, 47 Ω
R84	ERDS2TJ681	1/4W, 680 Ω
R86	ERDS2TJ681	1/4W, 680 Ω
R113	ERDS2TJ101	1/4W, 100 Ω
R114	ERDS2TJ330	1/4W, 33 Ω
R609	ERDS2TJ332	1/4W, 3.3k Ω
R610	ERDS2TJ332	1/4W, 3.3k Ω
R711	ERDS2TJ474	1/4W, 470k Ω
R712	ERDS2TJ474	1/4W, 470k Ω
R731	ERDS2TJ561	1/4W, 560 Ω
R732	ERDS2TJ561	1/4W, 560 Ω
R903	ERDS2TJ470	1/4W, 47 Ω
R906	ERDS2TJ334	1/4W, 330k Ω
R908	ERDS2TJ473	1/4W, 47k Ω
R916	ERDS2TJ124	1/4W, 120k Ω

■ TERMINAL GUIDE

● IC501 (MN662745RPC): Servo processor/Digital signal processor/Digital filter/D/A converter

Pin No.	Mark	I/O Division	Function
1	BCLK	O	Serial bit clock output
2	LRCK	O	L/R discriminating signal output
3	SRDATA	O	Serial data signal output
4	DVbd1	I	Power supply (digital circuit) terminal
5	DVss1	—	GND (digital circuit) terminal
6	TX	—	Digital audio interface signal (Not used, open)
7	MCLK	I	Command clock signal
8	MDATA	I	Command data signal
9	MLD	I	Command load signal ("L" : LOAD)
10	SENSE	—	Sense signal (OFT, FESL, NACEND, NAJEND, POSAD, SFG) (Not used, open)
11	FLOCK	—	Optical servo condition (focus) ("L" : lead-in) (Not used, open)
12	TLOCK	—	Optical servo condition (tracking) ("L" : lead-in) (Not used, open)
13	BLKCK	O	Sub-code block clock (f=75 Hz)
14	SQCK	I	Sub-code Q register clock
15	SUBQ	O	Sub-code Q data
16	DMUTE	I	Muting input ("H" : MUTE) (Not used, connected to GND)
17	STAT	O	Status signal (CRC, CUE, CLVS, TTSTOP, FCLV, SQCK)
18	RESET	I	Reset signal ("L" : reset)
19	SMCK	O	System clock (f=4.2336 MHz)
20	PMCK	O	Frequency division clock signal ($f = \frac{1}{1.92} \times ck = 88.2 \text{ kHz}$)
21	TRV	O	Traverse servo control

Pin No.	Mark	I/O Division	Function
22	TVD	O	Traverse drive signal
23	PC	O	Turntable motor drive signal ("L" : ON)
24	ECM	O	Turntable motor drive signal (Forced mode)
25	ECS	O	Turntable motor drive signal (Servo error signal)
26	KICK	O	Kick pulse output
27	TRD	O	Tracking drive signal output
28	FOD	O	Focus drive signal output
29	VREF	I	D/A drive output (TVD, ECS, TRD, FOD, FBAL, TBAL) normal voltage input terminal
30	FBAL	O	Focus balance adj. output (Not used, open)
31	TBAL	O	Tracking balance adj. output
32	FE	I	Focus error signal (analog input)
33	TE	I	Tracking error signal (analog input)
34	RFENV	I	RF envelope signal
35	VDET	I	Oscillation det. signal ("H" : det.)
36	OFTR	I	Off track signal ("H" : Off track)
37	TRCRS	I	Track cross signal input
38	RFDET	I	RF detection signal ("L" : detection)
39	BDO	I	Dropout detection signal ("H" : dropout)
40	LDON	O	Laser power control ("H" : ON)
41	TES	—	Tracking error shunt output ("H" : dropout) (Not used, open)
42	PLAY	—	Play signal ("H" : play) (Not used, open)

Pin No.	Mark	I/O Division	Function
43	WVEL	—	Double velocity status signal ("H" : double) (Not used, open)
44	ARF	I	RF signal input
45	IREF	I	Reference current input
46	DRF	—	DSL bias terminal (Not used, connected to GND)
47	DSLFL	O	DSL loop filter terminal
48	PLLF	I	PLL loop filter terminal
49	VCOF	I	VCO loop filter terminal (Not used, connected to AVDD2)
50	AVDD2	I	Power supply (analog circuit) terminal (2)
51	AVSS2	—	GND (analog circuit) terminal
52	FS384	—	384 fs (16.9344 MHz) output (Not used, open)
53	PCK	—	PLL extract clock (f=4.3218 MHz) (Not used, open)
54	TROF	—	Tracking servo OFF signal (Not used, open)
55	SUBC	—	Sub-code serial output data (Not used, open)
56	SBCK	—	Sub-code serial input clock (Not used, connected to GND)
57	VSS	—	GND terminal
58	X1	I	Crystal oscillator terminal (f=16.9344 MHz)
59	X2	O	
60	VDD	I	Power supply terminal
61	TRVSTOP	O	Traverse motor stop control terminal
62	CLDCK	—	Sub-code frame clock signal (f CLDCK=7.35 kHz: Normal) (Not used, open)

Pin No.	Mark	I/O Division	Function
63	FCLK	—	Crystal frame clock (Not used, open)
64	IPFLAG	—	Interpolation flag terminal
65	FLAGO	—	Flag terminal
66	CLVS	—	Turntable servo phase synchro signal ("H" : CLV, "L" : Rough servo) (Not used, open)
67	CRC	—	Sub-code CRC check terminal ("H" : OK, "L" : NG) (Not used, open)
68	DEMPHA	—	De-emphasis ON signal ("H" : ON) (Not used, open)
69	FLAG6	—	Flag terminal
70	SEL	—	Not used, connected to GND
71	TEST	I	Test terminal (Normal: "H")
72	AVDD1	I	Power supply (analog circuit) terminal (1)
73	OUTL	O	Lch audio signal
74	AVSS1	—	GND (analog circuit) terminal (1)
75	OUTR	O	Rch audio signal
76	RSEL	I	Polarity direction control terminal of RF signal (Not used, connected to power supply)
77	CSEL	I	Frequency control terminal of crystal oscillator (Not used, connected to GND)
78	ISRDATA	I	Serial data signal input
79	ILRCK	I	L/R discriminating signal input
80	IBCLK	I	Serial bit clock input

● IC11 (AN8788FB) : DC-DC converter & motor drive

Pin No.	Mark	I/O Division	Function
1	RESET	O	Reset signal input terminal
2	DED	I	Dead time input terminal
3	OUT	O	DC-DC converter output terminal
4	FB	O	Error amp output terminal
5	IN	I	Error amp input terminal
6	ROUT	O	Remote control interface output terminal
7	SGND	—	GND terminal
8	SPRO	I	Short protection input terminal
9	CT	I	Triangular wave oscillator terminal
10	AREF	O	1/2 AVDD output terminal
11	SV _{CC}	I	Power supply terminal
12	CRIP	I	Capacitor connection terminal for ripple filter
13	AV _{DD}	O	Ripple filter output terminal
14	DRV _{CC}	I	Power supply terminal
15	VREF	I	1/2 VCC input terminal
16	INFO	I	Focus coil drive input terminal
17	INTR	I	Tracking coil drive input terminal
18	LDON	I	Laser ON/ OFF drive control terminal
19	INSP	I	Spindle motor drive input terminal
20	PC	I	Spindle motor drive ON/OFF control terminal
21	INTV	I	Traverse motor drive control terminal
22	TRVSTOP	I	Traverse motor ON/ OFF control terminal

Pin No.	Mark	I/O Division	Function
23	TR-	O	Tracking coil drive output terminal
24	TR+		
25	FO-	O	Focus coil drive output terminal
26	FO+		
27 · 28	PGND	—	GND terminal
29	SP+	O	Spindle motor drive output terminal
30	SP-		
31	TRV+	O	Traverse motor drive output terminal
32	TRV-		
33	ICNT	I	Rechargeable current setting terminal
34	MRST	O	Muting reset output terminal
35	VSEN	I	Empty det. input terminal
36	EMPTY	O	Empty det. output terminal
37	PV _{CC1}	I	Power supply terminal
38	CLK	I	External synch. clock input terminal
39	START	I	Start oscillator input terminal
40	POWER	I	Power ON/ OFF input terminal
41	PV _{CC2}	I	Power supply terminal
42	I OUT	O	Rechargeable and battery det. terminal
43	DRGND	—	GND terminal
44	RIN	I	Remote control signal input terminal

● IC301 (SC440301FU): System control/LCD drive

Pin No.	Mark	I/O Division	Function
1 └ 6	FP6 └ FP1	O	LCD segment signal output terminal
7	BP3/FP0		
8 └ 10	BP2 └ BP0		
11 └ 13	VLCD3 └ VLCD1	I	Voltage control input terminal
14	V _{DD}	I	Power supply terminal
15	OSC1	I	Main system clock input terminal
16	OSC2	—	Not used, open
17	XOSC2	—	Not used, open
18	XOSC1	—	Not used, connected to GND
19	V _{SS}	—	GND terminal
20	RESET	O	Reset signal output terminal
21	STAT	I	Status signal input (CRC, CUE, CLVS, TT STOP, FCLV, SQOK)
22	BLKCK	I	Sub-code block clock (F=75Hz with normal play)
23	SUBQ	I	Sub-code Q data input terminal
24	SQCK	O	Sub-code Q register clock signal output terminal
25	MEMORY	I	Key switch input terminal (MEMORY)
26	REPEAT	I	Key switch input terminal (REPEAT)
27	STOP	I	Key switch input terminal (STOP)
28	PLAY	I	Key switch input terminal (PLAY/PAUSE)
29	RESUME	I	Key switch input terminal (RESUME)
30	RANDOM	I	Key switch input terminal (RANDOM)
31	HOLD	I	Key switch input terminal (HOLD)
32	EMPTY	I	Empty det. input terminal

Pin No.	Mark	I/O Division	Function
33	OPEN	I	Disc holder open det. terminal ("L" with open)
34	SKIP. R	I	Key switch input terminal (SKIP/SEARCH. R)
35	SKIP. F	I	Key switch input terminal (SKIP/SEARCH. F)
36	WRDRCN/ RSENSE	I/O	Remote control signal terminal
37	BUZ	O	Beep control signal output terminal
38	MODE2	—	Not used, connected to GND
39	POWER	O	Power ON/OFF signal output terminal
40	MUTE	O	Muting signal output terminal ("H" : mute)
41	MLD	O	Command load signal output terminal ("L" : load)
42	MDATA/ BATTERY	O	Command data signal output terminal
43	MCLK/ MODE1	O	Command clock signal output terminal
44	REST	I	Rest det. input terminal
45	RCLK/ STROBE1	O	Remote control clock signal output terminal
46	RDATA/ STROBE2	I/O	Remote control data signal terminal
47	ACDET	I	Power det. input terminal
48	CHARGE/ LIGHT	—	Not used, open
49	LCDREM	—	Not used, open
50	SHOCK. P	I	Key switch input terminal (not used connected to power supply)
51	ZSENSE	I	Sense signal input terminal
52	VUP	O	Reference current control output terminal
53 └ 54	FP18 └ FP17	—	Not used, open
55 └ 63	FP16 └ FP8	O	LCD segment signal output terminal
64	FP7	—	Not used, open

● IC502 (SM5856A1F) : Shock proof controller

Pin No.	Mark	I/O Division	Function
1	V _{DD} 1	I	Power supply terminal
2	UC1	I	Key input terminal (ANTI-SHOCK MEMORY)
3	XBS	—	Key input terminal (Not used, open)
4	BASS	—	Not used, open
5	ASC	—	Sound quality/sound field control terminal (Not used, open)
6	UC5	O	Sound quality/sound field control terminal
7	NTEST1	—	Test terminal (Not used, open)
8	NTEST2		
9	CLK	I	Clock signal input (f=16.9344MHz)
10	V _{SS}	—	GND terminal
11	YSRDATA	I	Serial data input terminal
12	YLCK	I	L/R clock input terminal
13	YSCK	I	Serial bit clock input terminal
14	ZSCK	O	Serial bit clock output terminal
15	ZLCK	O	L/R clock output terminal
16	ZSRDATA	O	Serial data output terminal
17	YFLAG	I	RAM over-flow flag terminal

Pin No.	Mark	I/O Division	Function
18	YFCLK	I	Crystal frame clock input
19	YBLKCK	I	Sub-cord block clock input terminal
20	RESET	I	Reset input terminal
21	ZSENSE	O	Microcomputer states output terminal
22	RAMSEL	I	Not used, open
23	YDMUTE	I	Mute input terminal
24	YMLD	I	Microcomputer latch clock input terminal
25	YMDATA	I	Microcomputer serial data input terminal
26	YMCLK	I	Microcomputer shift clock input terminal
27	NOE	O	D-RAM output enable terminal
28	NCAS	O	D-RAM column address strobe terminal
29 ┆ 32	D0 ┆ D3	I/O	D-RAM data input/output terminal
33	NWE	O	D-RAM write enable terminal
34	NRAS	O	D-RAM low address strobe terminal
35 ┆ 44	A0 ┆ A9	O	D-RAM address output terminal

● IC503 (LH6456K2) : 1M DRAM

Pin No.	Mark	I/O Division	Function
1	D0	I/O	Data input/output terminal
2	D1	I/O	Data input/output terminal
3	NWE	I	Write enable terminal
4	NRAS	I	Low address strobe terminal
5	A9	I	Address input terminal
6	A0	I	Address input terminal
7 ┆ 9	A1 ┆ A3	I	Address input terminal

Pin No.	Mark	I/O Division	Function
10	VCC	I	Power supply terminal
11 ┆ 15	A4 ┆ A8	I	Address input terminal
16	NOE	I	Output enable terminal
17	NCAS	I	Column address strobe terminal
18	D3	I	Data input terminal
19	D2	I	Data input terminal
20	GND	—	GND terminal

● IC101 (AN8837SBE1): Servo amp.

Pin No.	Mark	I/O Division	Function
1	PDE	I	Tracking signal input terminal (1)
2	PDF	I	Tracking signal input terminal (2)
3	Vcc	J	Power supply terminal
4	PDA	I	Focus signal input terminal (1)
5	PDB	I	Focus signal input terminal (2)
6	LPD	I	APC amp input terminal
7	LD	O	APC amp output terminal
8	RF	O	RF summing output terminal
9	RF IN	I	RF signal input terminal
10	CSBRT	O	Capacitor connection terminal for OFTR
11	CEA	O	Capacitor connection terminal for H.P.F. amp
12	BDO	O	Dropout signal output terminal ("H" : Dropout)
13	LDON	I	APC control input terminal
14	GND	—	GND terminal

Pin No.	Mark	I/O Division	Function
15	/RFDET	O	RF det. signal output terminal ("L" : Det.)
16	CROSS	O	Track cross signal output terminal
17	OFTR	O	Off track signal output terminal ("H" : Off track)
18	VDET	O	Vibration det. signal output terminal ("H" : Det.)
19	ENV	O	RF envelope signal output terminal
20	ENV OFF	I	ENV control input terminal
21	TEBPF	I	VDET input terminal
22	TE IN	I	Tracking error amp input terminal
23	TE OUT	O	Tracking error amp output terminal
24	FE OUT	O	Focus error amp output terminal
25	FE IN	I	Focus error amp input terminal
26	VREF	O	Reference voltage output terminal
27	TBAL	I	Tracking balance signal input terminal
28	FBAL	I	Focus balance signal input terminal

■ REPLACEMENT PARTS LIST

Notes: * Important safety notice:

Components identified by Δ mark have special characteristics important for safety.

Furthermore, special parts which have purposes of fire-retardant (resistors), high-quality sound (capacitors), low-noise (resistors), etc. are used.

When replacing any of components, be sure to use only manufacturer's specified parts shown in the parts list.

* Warning: This product uses a laser diode. Refer to caution statements on page 2.

* ACHTUNG: Die Lasereinheit nicht zerlegen.

Die Lasereinheit darf nur gegen eine vom Hersteller spezifizierte Einheit ausgetauscht werden.

Ref. No.	Part No.	Part Name & Description	Remarks	Ref. No.	Part No.	Part Name & Description	Remarks
		CABINET AND CHASSIS		7	RYF0402F-K	CD COVER ASS'Y	
				8	RGPO538-Q	LCD PANEL	
				9	RGU1368-H	OPERATION BUTTON(A)	
				10	RGU1369-H	OPERATION BUTTON(B)	
1	RKK0065-KJ	BATTERY COVER		11	RHE5119YA	SCREW	
2	RJF0026	LCD HOLDER		12	RFKLS240P-K	INTERMEDIATE CABINET ASS'Y	
3	RGV0145-K	XBS/MODE/HOLD KNOB		13	RME0210	OPEN SPRING	
4	RJC93020	COMMON BATTERY TERMINAL		14	XTN17+6GFZ	SCREW	
5	RFKJLXP240EK	BOTTOM CABINET ASS'Y	(E, EG)	15	RAED141Z	TRAVERSE DECK	Δ
5	RFKJLXP240EB	BOTTOM CABINET ASS'Y	(EB)	15-1	SHGD157	FLOATING RUBBER(1)	
5	RFKJLXP240GC	BOTTOM CABINET ASS'Y	(GC, GN)	15-2	SHGD165	FLOATING RUBBER(2)	
5-1	RKA0063-K	FOOT		16	RGV0145-H	ANTI-SHOCK KNOB	
6	RMA0677	REAR ORNAMENT					

CABINET PARTS LOCATION

Note: When changing loading mechanism parts, apply the specified grease to the areas marked "XX" as shown in the drawing.

Ref. No.	Part No.
A	RFKXPG671

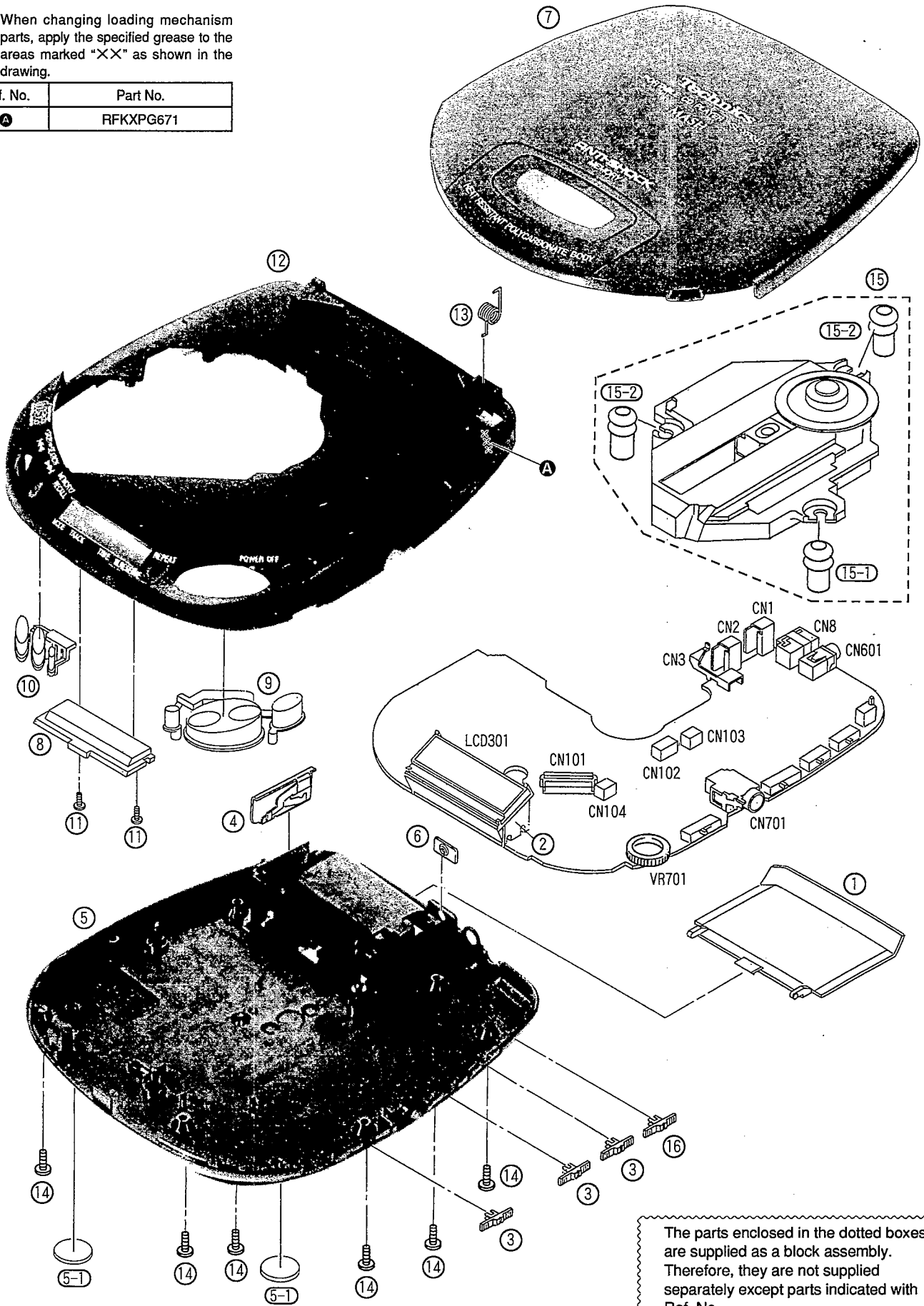

The parts enclosed in the dotted boxes are supplied as a block assembly. Therefore, they are not supplied separately except parts indicated with Ref. No.

REPLACEMENT PARTS LIST

Notes: * Important safety notice:

 Components identified by Δ mark have special characteristics important for safety.

Furthermore, special parts which have purposes of fire-retardant (resistors), high-quality sound (capacitors), low-noise (resistors), etc. are used.

When replacing any of components, be sure to use only manufacturer's specified parts shown in the parts list.

* The parenthesized indications in the Remarks columns specify the areas. (Refer to the cover page for area.)

Parts without these indications can be used for all areas.

* Warning: This product uses a laser diode. Refer to caution statements on page 2.

* ACHTUNG: Die Lasereinheit nicht zerlegen.

Die Lasereinheit darf nur gegen eine vom Hersteller spezifizierte Einheit ausgetauscht werden.

Ref. No.	Part No.	Part Name & Description	Remarks	Ref. No.	Part No.	Part Name & Description	Remarks
		INTEGRATED CIRCUIT(S)				COIL(S)	
IC11	AN8788FB	DC-DC CONV. / MOTOR DRIVE		L12	RLZ0028T-0	COIL	
IC101	AN8837SBE1	SERVO AMP		L502	RLQU331KT-W	COIL	
IC301	SC440301FU	SYSTEM CONT. / LCD DRIVE		L601, 602	RLB0003	COIL	
IC501	MN662745RPC	SERVO PROCESSOR				OSCILLATOR(S)	
IC502	SM5856A1F	SHOCK PROOF CONTROLLER					
IC503	LH6456K2	1M DRAM					
IC701	NJU7082AMTE1	HEADPHONES AMP		X501	RSX216M9M01T	OSCILLATOR (16.9344MHz)	
		TRANSISTOR(S)				LCD(S)	
Q11	2SD2074HWRST	TRANSISTOR		LCD301	RSL5156-L	LCD	
Q12, 13	2SD1450STTA	TRANSISTOR				SWITCH(ES)	
Q203	2SB709QRS1X	TRANSISTOR					
Q501	2SB970RSTX	TRANSISTOR		S201	ESE11SV1	LASER ON/OFF	
Q502	UN5113TX	TRANSISTOR		S202	SSH1-2	REST DETECTOR	
Q503, 504	UN5211TX	TRANSISTOR		S301	EVQ21405R	MEMORY/RECALL	
Q505	UN5215TX	TRANSISTOR		S302	EVQ21405R	REPEAT	
Q506	FMW1T98	TRANSISTOR		S303	EVQ21405R	SKIP/SEARCH(R)	
Q507	DTA143TUT107	TRANSISTOR		S304	EVQ21405R	SKIP/SEARCH(F)	
Q601, 602	2SD1328QRSTX	TRANSISTOR		S305	EVQ21405R	STOP/POWER OFF	
Q603	FMG4T148	TRANSISTOR		S306	EVQ21405R	PLAY/PAUSE	
Q701, 702	2SD1328QRSTX	TRANSISTOR		S307	ESD11H230	PLAY MODE SELECTOR	
Q904	UN5114TX	TRANSISTOR		S308	ESD11H220	HOLD	
Q905, 906	2SD1819QRSTX	TRANSISTOR		S501	ESD11H220	ANTI-SHOCK	
		DIODE(S)		S701	ESD11H220	XBS SELECTOR	
						CONNECTOR(S) AND JACK(S)	
D11	SS14G11	DIODE		CN1	RJC93015-1	BATTERY TERMINAL(+)	
D301	MA151WKTX	DIODE		CN2	RJC93015-1	BATTERY TERMINAL(-)	
D501	MA8047MTX	DIODE		CN3	RJH5102-1	RECHARGEABLE BATT. TERMINAL	
D502	1SS355TE17	DIODE		CN8	RJJ43K09-C	DC IN JACK	
D701	MA8051MTX	DIODE		CN101	RJU035T016-1	SOCKET(16P)	
D903	MA151WKTX	DIODE		CN102	RJT068W04V	CONNECTOR(4P)	
		IC PROTECTOR(S)		CN103, 104	RJT068W02V	CONNECTOR(2P)	
ICP11	UNH00500A	IC PROTECTOR	Δ	CN601	RJD3S5ZB-C	OUT JACK	
		VARIABLE RESISTOR(S)		CN701	RJJ34TH02-C	HEADPHONES JACK	
						PACKING MATERIAL	
VR11	EVNDXAA00B33	POWER SUPPLY VOLTAGE ADJ.		P1	RPK0752	PACKING CASE	
VR701	EVUT2FA26C54	VOLUME					

Ref. No.	Part No.	Part Name & Description	Remarks	Ref. No.	Part No.	Part Name & Description	Remarks
P2	RPQ0660	SPACER		A7	SJP5213-2	POWER PLUG ADAPTOR	(GC) △
P3	RPF0111	PROTECTION BAG (UNIT)		A8	RP-BP60EYS1	RECHARGEABLE BATTERIES	(E, EB, EG)
P4	RPF0046	PROTECTION BAG (F. B.)		A8	RP-BP60SYS2	RECHARGEABLE BATTERIES	(GC, GN)
		ACCESSORIES		A8-1	RFRNLS370-K	BATTERY CARRING CASE	
						<PRINTED CIRCUIT BOARDS	
						ASS' Y>	
A1	RFKSLXP240EK	INSTRUCTION MANUAL ASS' Y	(E)	PCB1	REP2239C-M	MAIN P. C. B. ASS' Y	(RTL)
A1	RQT3400-B	INSTRUCTION MANUAL	(EB, GN)			<GREASE OR JIG/TOOL>	
A1	RFKSLXP240EG	INSTRUCTION MANUAL ASS' Y	(EG)			TEST DISC	
A1	RFKSLXP240GC	INSTRUCTION MANUAL ASS' Y	(GC)	SA1	SZZP1054C	PLAYABILITY TEST DISC	
A2	RFEA401E-2S	AC ADAPTOR	(E, EG) △	SA2	SZZP1056C	UNEVEN TEST DISC	
A2	RFEA404B-1W	AC ADAPTOR	(EB) △			GREASE	
A2	RFEA403Z-S	AC ADAPTOR	(GC) △	SA3	RFKXPG671	MOLYCOAT GREASE PG671	
A2	RFEA403A-S	AC ADAPTOR	(GN) △				
A3	RQA0117	WARRANTY CARD	(E, EB, EG)				
A3	RQX7433ZA	WARRANTY CARD	(GN)				
A4	RQCB0169	SERVICENTER LIST					
A5	RFEV317A-KS	STEREO EARPHONES					
A6*	RKB205ZA-0	EAR PADS					

*This item is not attached to merchandise, but it is supplied as a replacement part.

- The marking (RTL) indicates that the Retention Time is limited for this item. After the discontinuation of this assembly in production, the item will continue to be available for a specific period of time. The retention period of availability is dependant on the type of assembly, and in accordance with the laws governing part and product retention. After the end of this period, the assembly will no longer be available.

PACKAGING

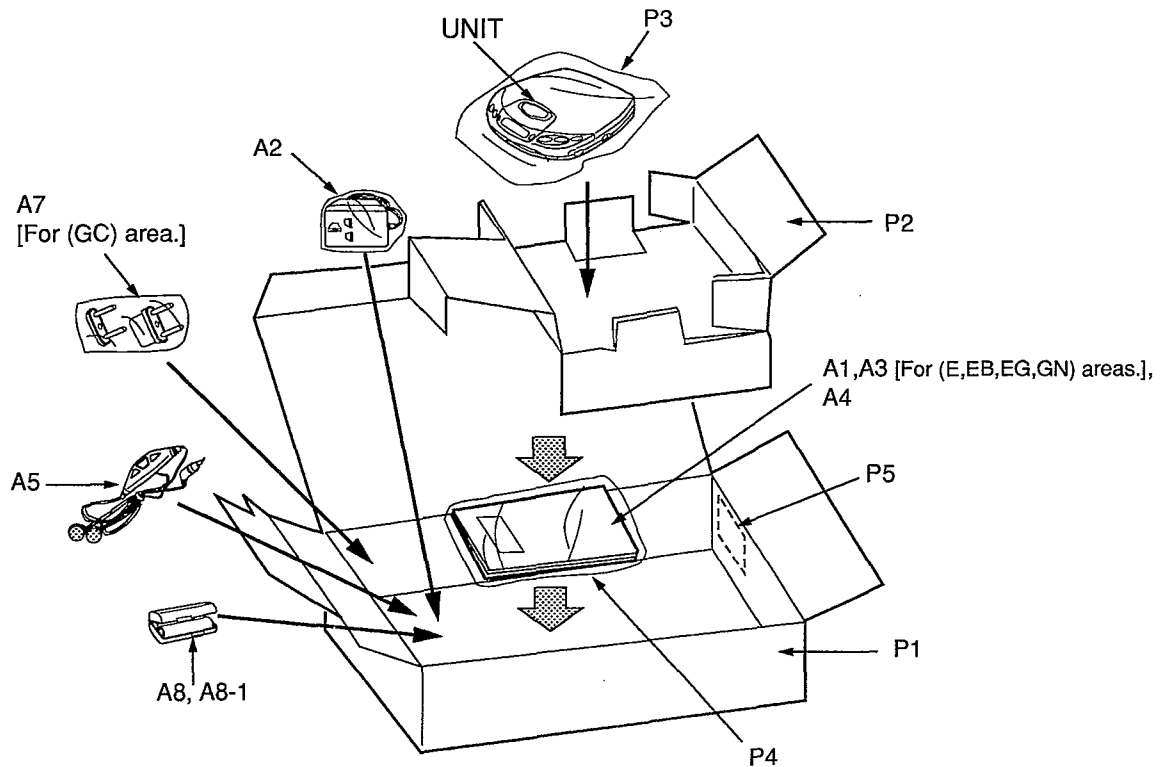

1165

RESISTORS AND CAPACITORS

Notes: * Capacity values are in microfarads (uF) unless specified otherwise, P=Pico-farads (pF) F=Farads (F)
* Resistance values are in ohms, unless specified otherwise, 1K=1,000 (OHM), 1M=1,000k (OHM)

Ref. No.	Part No.	Values & Remarks	Ref. No.	Part No.	Values & Remarks
		RESISTORS	C120	ECUV1H332KBN	50V 3300P
			C121	ECUV1H221KBN	50V 220P
			C204	RCE1AKA470IG	10V 47U
R16	ERJ6GEYJ100	1/10W 10	C205	ECUVNE104ZFN	25V 0.1U
R29	ERJ6GEYJ821V	1/10W 820	C301, 302	ECUVNE104ZFN	25V 0.1U
R208	ERJ6GEYJ4R7V	1/10W 4.7	C303	ECUV1E103KBN	25V 0.01U
R409	ERJ6GEYJ824V	1/10W 820K	C404	ECUVNC105ZFN	16V 1U
R501	ERJ6GEYJ683V	1/10W 68K	C405	ECUVNE104KBN	25V 0.1U
R504	ERJ6GEYJ474V	1/10W 470K	C501, 502	ECUV1H150KCN	50V 15P
R505	ERJ6GEYJ221V	1/10W 220	C503	ECUV1H561KBN	50V 560P
R507	ERJ6GEYJ4R7V	1/10W 4.7	C504	ECUV1C473KBN	16V 0.047U
R510	ERJ6GEYJ120V	1/10W 12	C505	ECUV1E223KBN	25V 0.022U
R512	ERJ6GEYJ471V	1/10W 470	C506	ECUVNC474KBN	16V 0.47U
R513	ERJ6GEYJ222V	1/10W 2.2K	C507	ECEAOGKA221	4V 220U
R719, 720	ERJ6GEYJ103V	1/10W 10K	C508, 509	ECUVNE104ZFN	25V 0.1U
R725, 726	ERJ6GEYJ180V	1/10W 18	C511	ECUVNC474KBN	16V 0.47U
R727, 728	ERJ6GEYK1R5V	1/10W 1.5	C512	ECUV1E103KBN	25V 0.01U
		CHIP JUMPERS	C513	RCST1AY475RE	10V 4.7U
			C517	ECUVNE104ZFN	25V 0.1U
			C518	ECUV1E103KBN	25V 0.01U
RJ11-14	ERJ6GEYOR00V	CHIP JUMPER	C525	ECUVNE104ZFN	25V 0.1U
RJ301	ERJ6GEYOR00V	CHIP JUMPER	C526	RCSTOJY475LE	6.3V 4.7U
RJ701, 702	ERJ6GEYOR00V	CHIP JUMPER	C527	ECUVNE104ZFN	25V 0.1U
RJ904	ERJ6GEYOR00V	CHIP JUMPER	C600	ECUVNE104ZFN	25V 0.1U
		CAPACITORS	C601, 602	ECUV1H102KBN	50V 1000P
			C603, 604	ECUV1H272KBN	50V 2700P
			C605, 606	ECEA1CKA100I	16V 10U
C13	RCE0JSL470IX	6.3V 47U	C607, 608	ECUV1H681KBN	50V 680P
C14	ECEAOGKA221	4V 220U	C609	ECUVNE104ZFN	25V 0.1U
C16	ECUVNC224KBN	16V 0.022U	C610	RCE1AKA470IG	10V 47U
C17	ECUV1H470KCN	50V 47P	C703, 704	ECUV1E123KBN	25V 0.012U
C18	ECUV1E103KBN	25V 0.01U	C705, 706	ECUV1H152KBN	50V 1500P
C19	ECEA1AKA220I	10V 22U	C709, 710	ECEAOGPK221I	4V 220U
C20	ECEA1EKA4R7I	25V 4.7U	C711, 712	ECEA1CPK100I	16V 10U
C21	ECUV1E223KBN	25V 0.022U	C713	RCE1AKA470IG	10V 47U
C22	ECUVNE104KBN	25V 0.1U	C717	ECUVNE104ZFN	25V 0.1U
C24	ECUV1H391KBN	50V 390P			
C25	ECEA1HKA010I	50V 1U			
C27-29	RCE1AMT3311V	10V 330U			
C32	ECUV1E103KBN	25V 0.01U			
C101	ECUVNE104KBN	25V 0.1U			
C103	ECUV1E273KBN	25V 0.027U			
C108	ECUV1C473KBN	16V 0.047U			
C109	ECUV1C333KBN	16V 0.033U			
C110	ECUV1E223KBN	25V 0.022U			
C111	ECUV1E273KBN	25V 0.027U			
C112	ECUV1H391KBN	50V 390P			
C113, 114	ECUVNE104ZFN	25V 0.1U			
C115	ECUV1E223KBN	25V 0.022U			