

Service Manual

QUARTZ Synthesizer
Direct Drive Turntable

SP-15 (M), (MC)

SP-15



- The model SP-15 (M) is available in America only.
- The model SP-15 (MC) is available in Canada only.

Specifications (Specifications are subject to change without notice.)
(Weights and dimensions shown are approximate.)

General

Power supply:	120V, 50 or 60 Hz
Power consumption:	11W
Dimensions: (W x H x D)	34.9 x 9.3 x 37.2 cm (13-3/4x3-21/32x14-41/64 inches)
Weight:	6.2 kg (13.7 lb)

Turntable section

Type:	Quartz synthesizer pitch control Direct drive
Drive method:	Direct Drive
Motor:	Brushless DC motor
Drive control method:	Quartz-phase-locked control
Turntable platter:	Aluminum die-cast, diameter 33.9 cm (13-11/32 inches) weight 2.7 kg (5.9 lb)
Moment of inertia:	380 kg-cm ² (130 lb-in ²)

Turntable speeds:	33-1/3, 45 and 78.26 rpm
Turntable speed fine adjustment:	Adjustable up to ±9.9% in 0.1% increments by digital indication
Starting torque:	3 kg-cm (2.61 lb-in)
Build-up time:	0.4 sec. to 33-1/3 rpm
Braking time:	0.4 sec. from 33-1/3 rpm
Braking system:	Electrical and Mechanical braking
Speed fluctuation due to load torque:	0% within 2.5 kg-cm (2.2 lb-in)
Speed drift:	Within ±0.002%
Wow and flutter:	0.025% WRMS (JIS C5521) ±0.035% peak (IEC 98A Weighted) -56 dB (IEC 98A Unweighted) -78 dB (IEC 98A Weighted)
Rumble:	

Technics

Panasonic Company
Division of Matsushita Electric
Corporation of America
One Panasonic Way, Secaucus,
New Jersey 07094

Panasonic Hawaii, Inc.
320 Waiakamilo Road, Honolulu,
Hawaii 96817

Matsushita Electric of Canada Ltd.
5770 Ambler Drive
Mississauga, Ontario
L4W 2K9

■ DIMENSION DRAWING

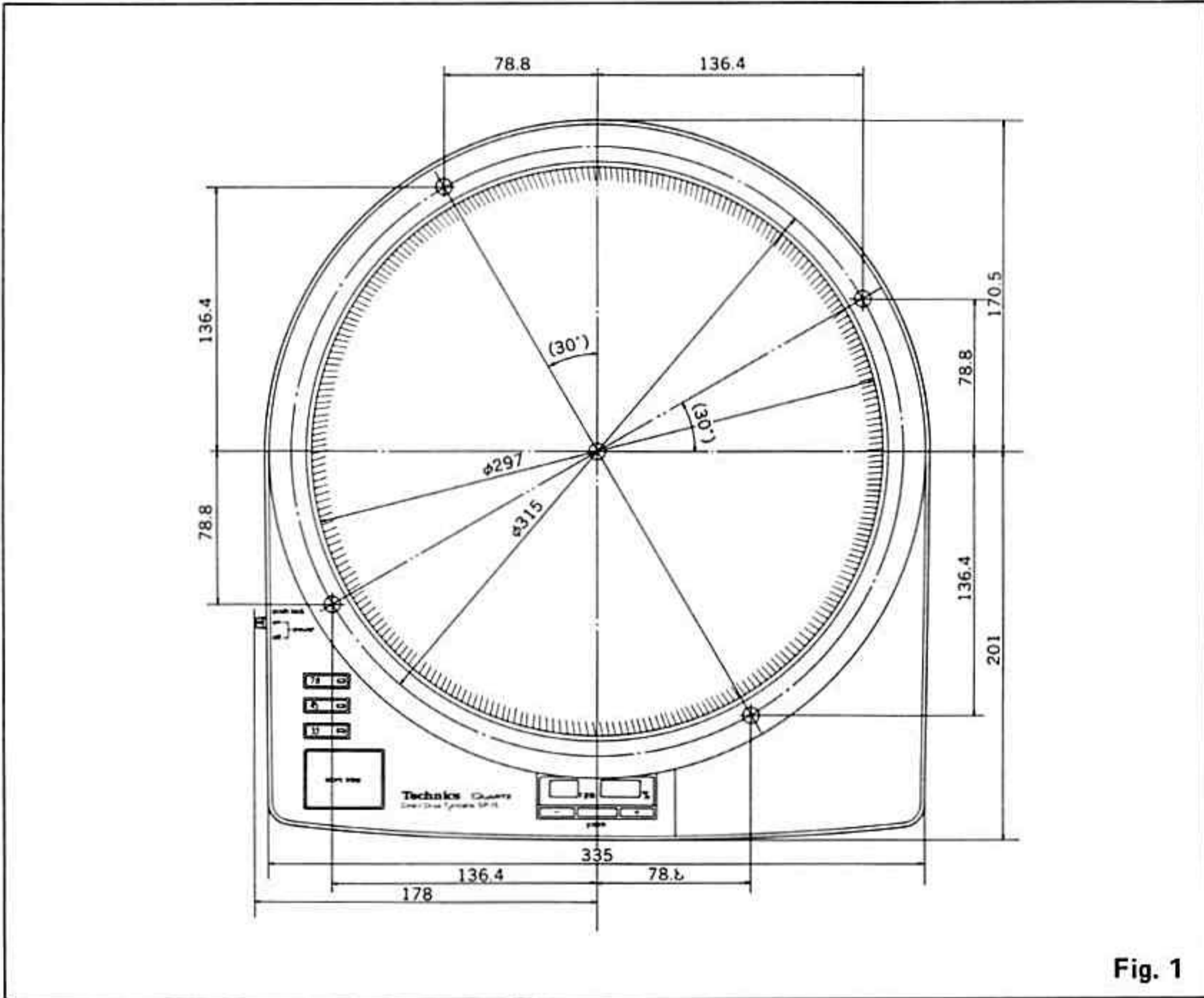

Fig. 1

NOTE:

- Secure the main body with the attached 4 setscrews. When other setscrews are used, find suitable ones in accordance with the dimension drawing.
- In order to make the best use of this turntable, employ a sturdy cabinet (turntable base) which sufficiently withstands the load.
- * It is recommended to use the optional turntable (SH-15B1) as the cabinet for SP-15.

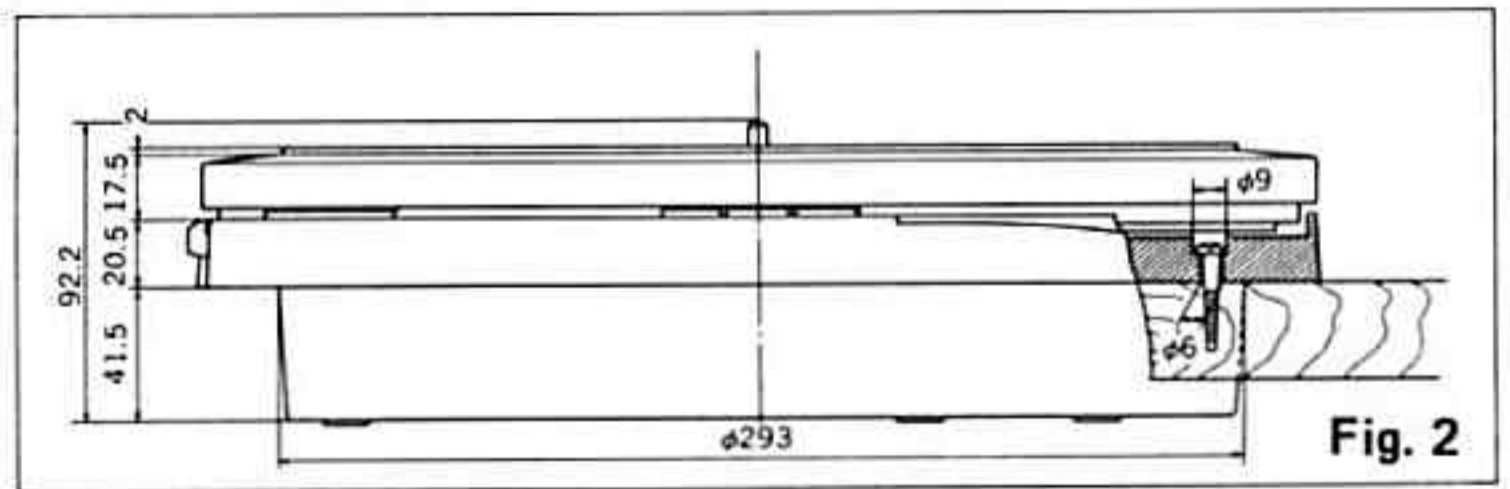

Fig. 2

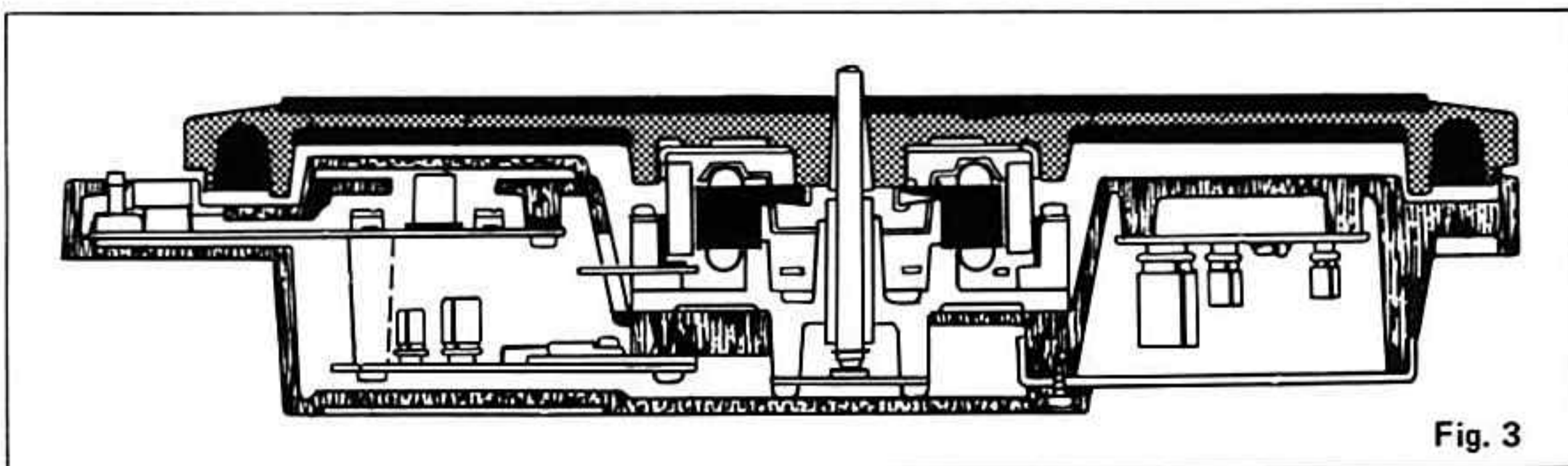

Fig. 3

HOW TO OPERATE

1. Set the Power switch/pitch lock knob to the "on" position. (See Fig. 4.)

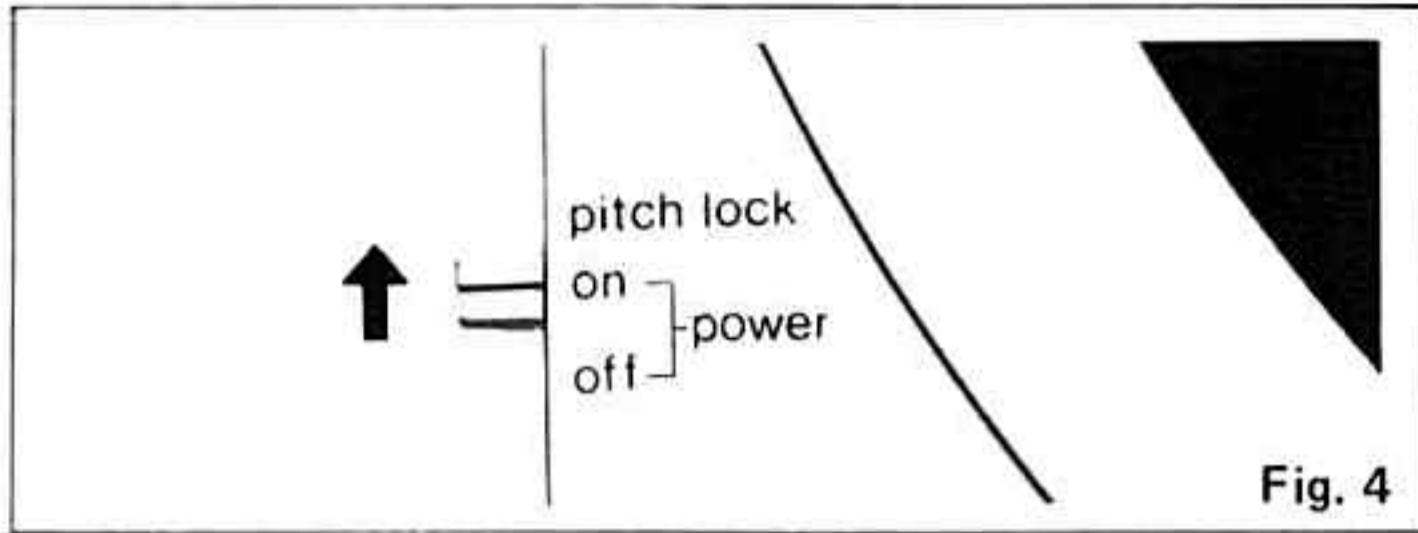

Fig. 4

The revolutions are indicated at 33 (33-1/3 rpm.) of the speed selector knob and digital speed indicator. (Fig. 5.)

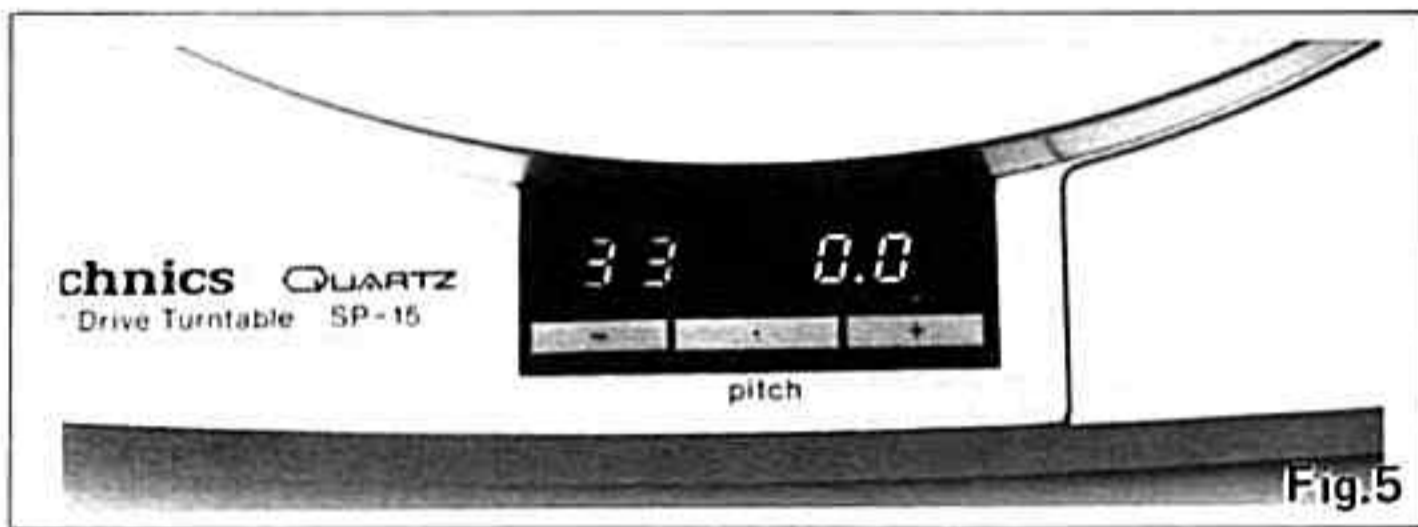

Fig. 5

Upon setting the power switch/pitch lock knob to "on", the revolutions are changed over to 33-1/3 rpm. at all times. If the record to be played is other than a 33-1/3 rpm., depress the speed select button to suit the phono disc to be played.

When the power switch/pitch lock knob is set to "pitch lock", the pitch control button and speed select button are locked so as not to be actuated even if the buttons are accidentally touched during playing. (See Fig. 6.)

Therefore, for selecting the speeds or operating the pitch control, first set the power switch/pitch lock knob to the position "on".

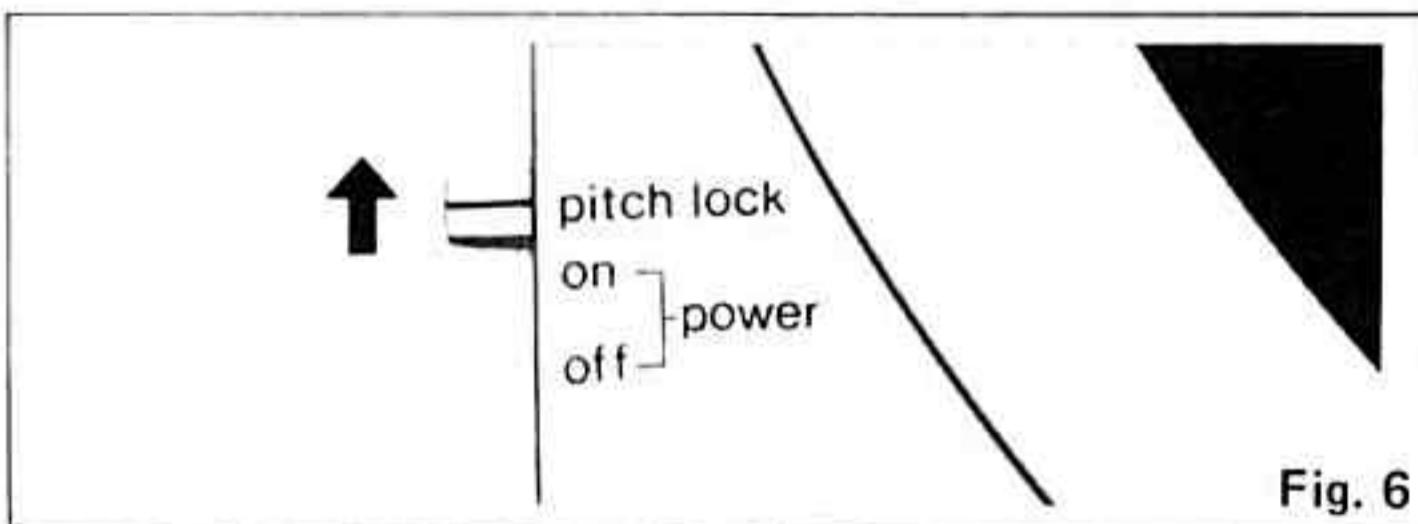

Fig. 6

2. Place a record on the turntable mat. Push the start • stop button. (See Fig. 7.) The turntable platter will begin to rotate and reach its constant rotation speed 0.4 sec. (33-1/3 rpm.).

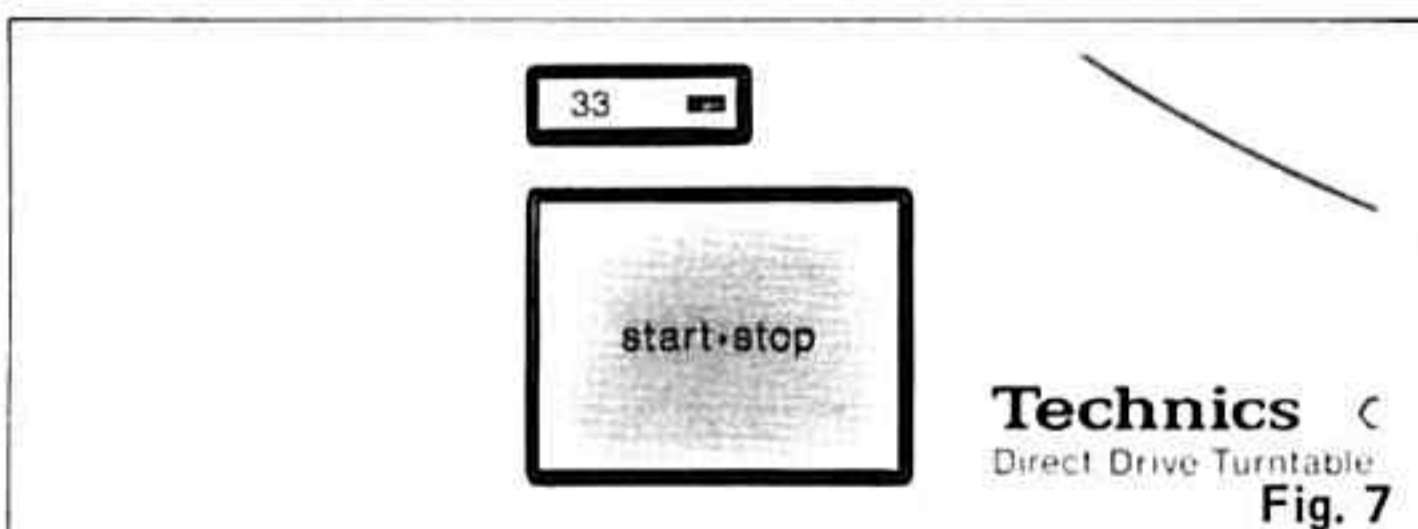

Fig. 7

3. Upon completion of playing, depress the start • stop button. The turntable is instantly (0.4 second) stopped by the double brake system.
4. After that, set the power switch/pitch lock knob to "off". (See Fig. 8.)

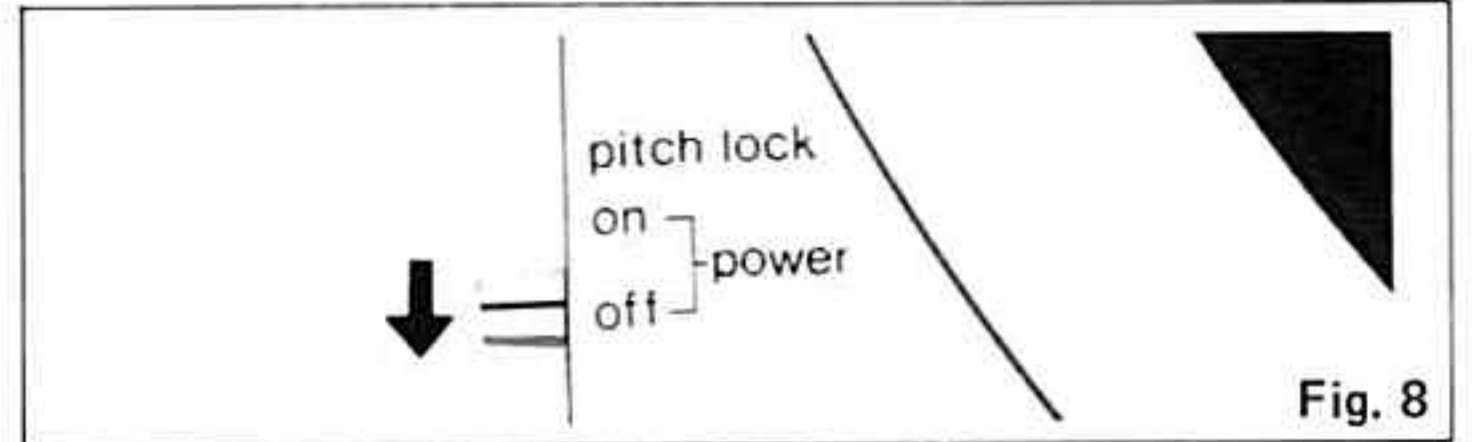

Fig. 8

Pitch control (turntable speed fine adjustment).

The Quartz synthesizer system is being employed for the first time in the world. A high degree of pitch control accuracy over a wide range ($\pm 9.9\%$) in 0.1% increments can be obtained with the quartz perfectly locked.

The pitch control is continuously variable up to 9.9%.

The pitch variations which are clearly indicated by the LED digital indicator provide you with accurate and easy selection.

The pitch control can be selected in increments of 0.1% which is below the threshold of human perception. (See Fig. 9.)



Fig. 9

The pitch control also enables you to accurately and precisely tune musical instruments and by varying the pitch slightly, to obtain a different musical note from the record. (See Fig. 10.)

For a half-tone change:

+5.9% (#)

-5.6% (b)

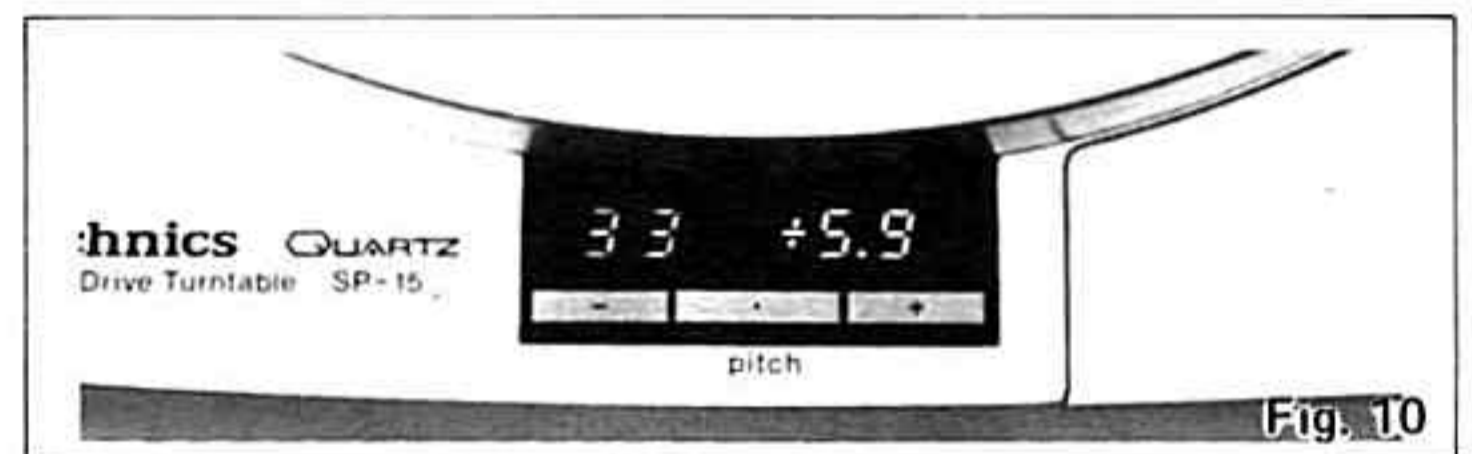

Fig. 10

Another feature of the variable pitch control over a wide range of $\pm 9.9\%$ is that it makes singing along with a melody easy for a chorus, or for playing a record for accompaniment only. (See Fig. 11.)

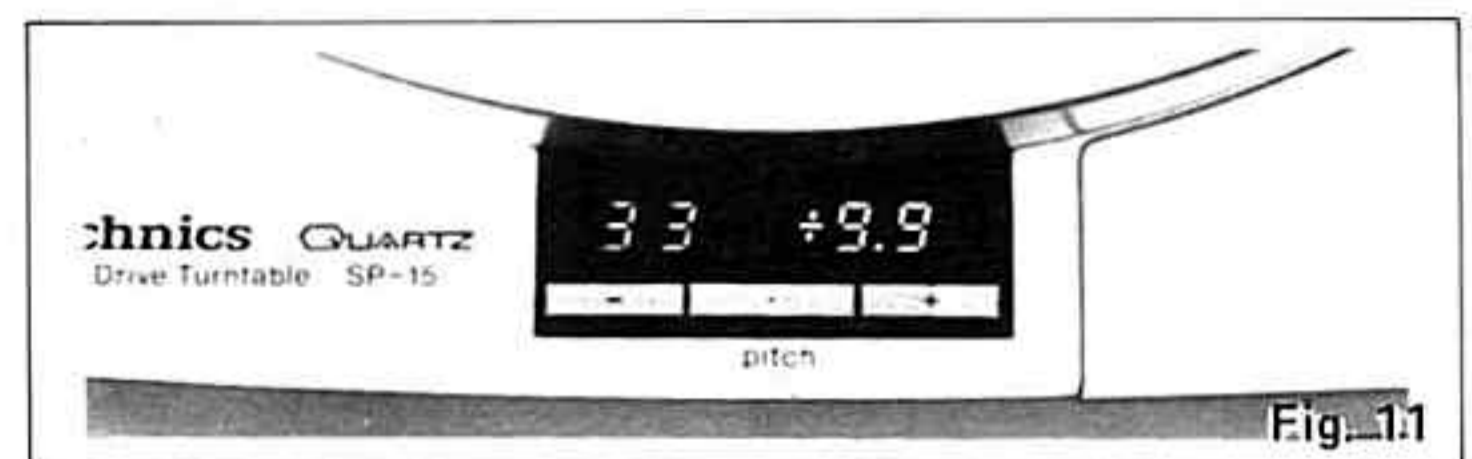

Fig. 11

By pressing the clear button which is located between the "+" and "-" pitch buttons, you can quickly return the set to normal playing speed. (See Fig. 12.)

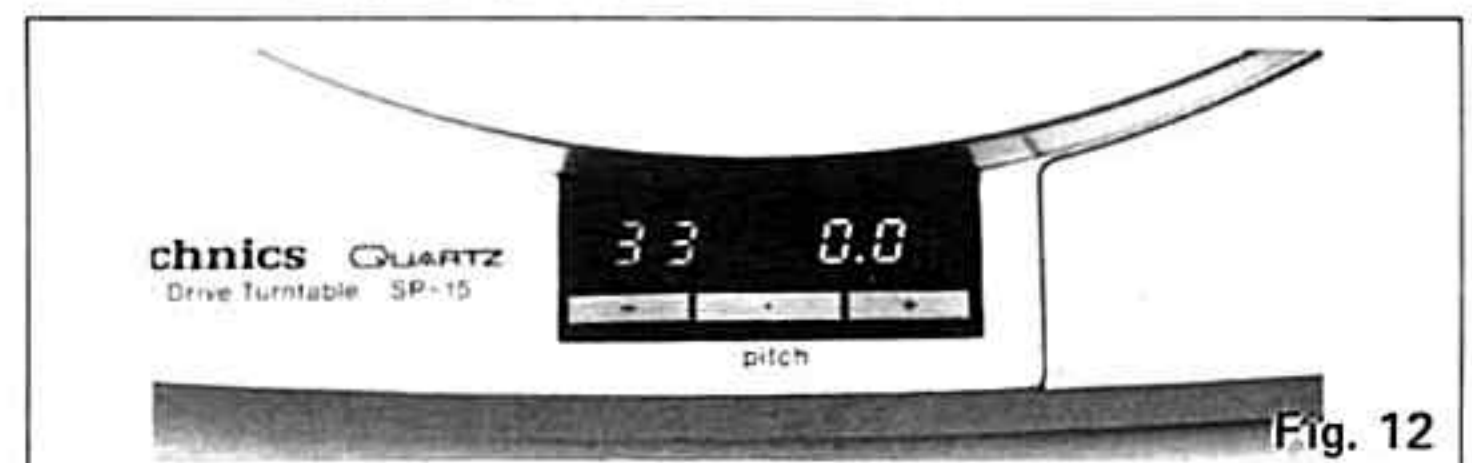

Fig. 12

SP-15

■ FEATURES

Quartz synthesizer system that for the first time in the world has made it possible to achieve a digital pitch control of $\pm 9.9\%$ in 0.1% increments

In conventional quartz players the quartz reference was in effect only within strictly limited ranges: whenever vernier speed change was required, the quartz circuit had to be switched off. In the Technics SP-15, we took the lead by locking the quartz, thus making it possible to effect a high degree of pitch control accuracy over a range as wide as $\pm 9.9\%$ in 0.1% increments, which is below the threshold of human perception.

Moreover, the pitch control, coupled with the clear digital indicator, enables you to accurately and precisely tune with musical instruments, vary pitch slightly for obtaining a musical note from a record or alter tones by a half-note.

Oversized turntable that cuts off and absorbs external vibrations.

Based on analyses of the turntable vibration modes and vibrations in the sound range, a special viscoelastic material is applied to the reverse surface of the turntable platter for deadening.

The deadening material is applied to the undersurface and outer periphery of the turntable platter, with the rubber turntable mat on the surface settled into the turntable platter. This design is superior in acoustic characteristics even at high sound levels through elimination of turntable resonance and absorption of external vibration.

Moreover, the oversized aluminum die-cast turntable platter, 33.9 cm (13-11/32") in diameter, is heavy with 2.7 kg (5.9 lb.) of its own weight, with a moment of inertia of 380 kg cm² (130 lb. in²) for large heavy weight class design.

Vibration damping structure by the precision aluminum die-cast cabinet and TNRC.

The acoustical characteristics of the player system are inevitably affected by the turntable platter and cabinet employed. The SP-15 adopts an aluminum die-cast cabinet superior in strength, with high processing accuracy, and the new acoustic material TNRC excellent in acoustical properties. Through cutting-off and absorption of external vibrations, the unit is designed for improved acoustic characteristics, with susceptibility to feedback minimized.

Electronic circuits of more than 3,000 discrete elements concentrated into 4ICs

The 4 kinds of IC, i.e., Synthesizer pitch control CMOS LSI (MN 6042), Frequency dividing IC employing I²L, ECL

(DN 860), phase speed control IC (AN 660) and Driving IC (AN 640) into which high density electronic circuits of more than 3,000 discrete elements have been compressed have made it possible to produce this high precision quartz turntable.

Quartz Controlled Rotation Accuracy

The SP-15 utilizes the oscillation of a quartz crystal as a reference signal or source. This oscillation is not affected by temperature change or power fluctuations. By synchronizing the rotation of the turntable platter accurately to the reference signal, speed drift of the unit is held within $\pm 0.002\%$.

Technics' unique motor construction in which the rotor of the motor is integrally formed with the turntable

High torque motor of 3 kg-cm with starting time of 0.4 second is capable of instant speed change-over (at 33-1/3 rpm.).

With the double braking system of the electronic brake and mechanical brake, the turntable stops instantly (0.4 second) upon depression of the start • stop button (at 33-1/3 rpm.)

High performance with wow and flutter of only 0.025% (JIS C5521) and rumble of -78 dB (IEC 98A Weighted).

Pitch lock mechanism capable of locking the speed selection and pitch control operation

Malfunction caused by accidental touching of the operating portion during playing, can be prevented.

Highly efficient pulse power supply circuit is employed for the DC power source

Since DC voltage is obtained by oscillating high frequency (20 kHz) through direct rectification of AC power supply for voltage conversion at the pulse transformer, there is no leakage of the commercial power source frequency.

Stable and positive mechanism that can stand frequent use for business use, etc. and a switch section with point contacts.

Revolutions at 3 speeds of 33-1/3, 45 and 78.26 rpm. are employed, taking into account business use.

■ RUBRICATION

Apply 2 or 3 drops of oil once after every 2000 hours of operation. (See Fig. 13.)

This time interval is much longer than that of conventional type motors (200-500 hours).

Please purchase original brand of oil (Parts number is SFWO 010.)

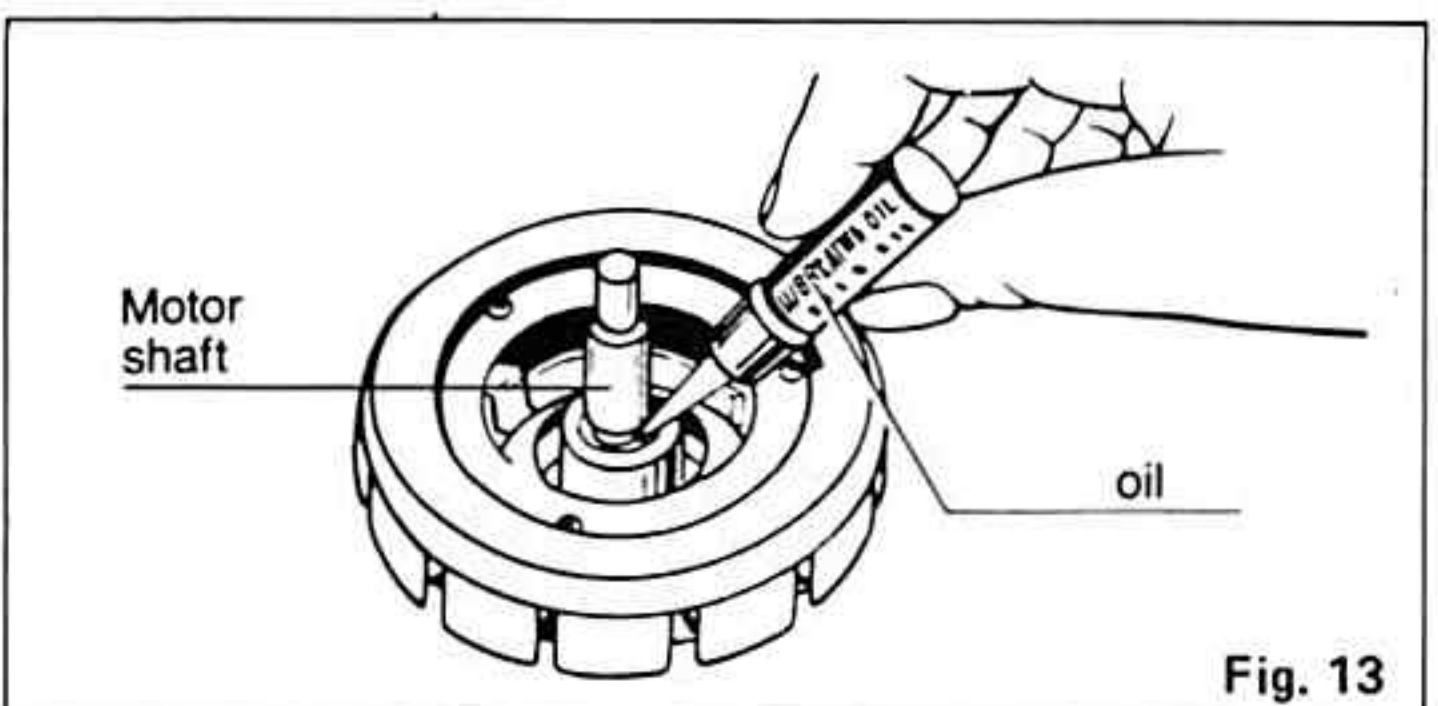

Fig. 13

■ TECHNICAL DESCRIPTION

• Description of pulse power supply circuit

The pulse power source directly rectifies the commercial power with diode to make DC 168V. And it generates pulses (approx. 20 kHz waves) by switching the DC 168V with the special high-voltage withstanding, high-speed switching transistor. Thus, the circuit serves to drive the power transformer with the switching pulses in order to obtain the specified voltage on the secondary side.

Fig.14 shows a pulse power supply block and a conventional power supply block.

Power supply circuit blocks

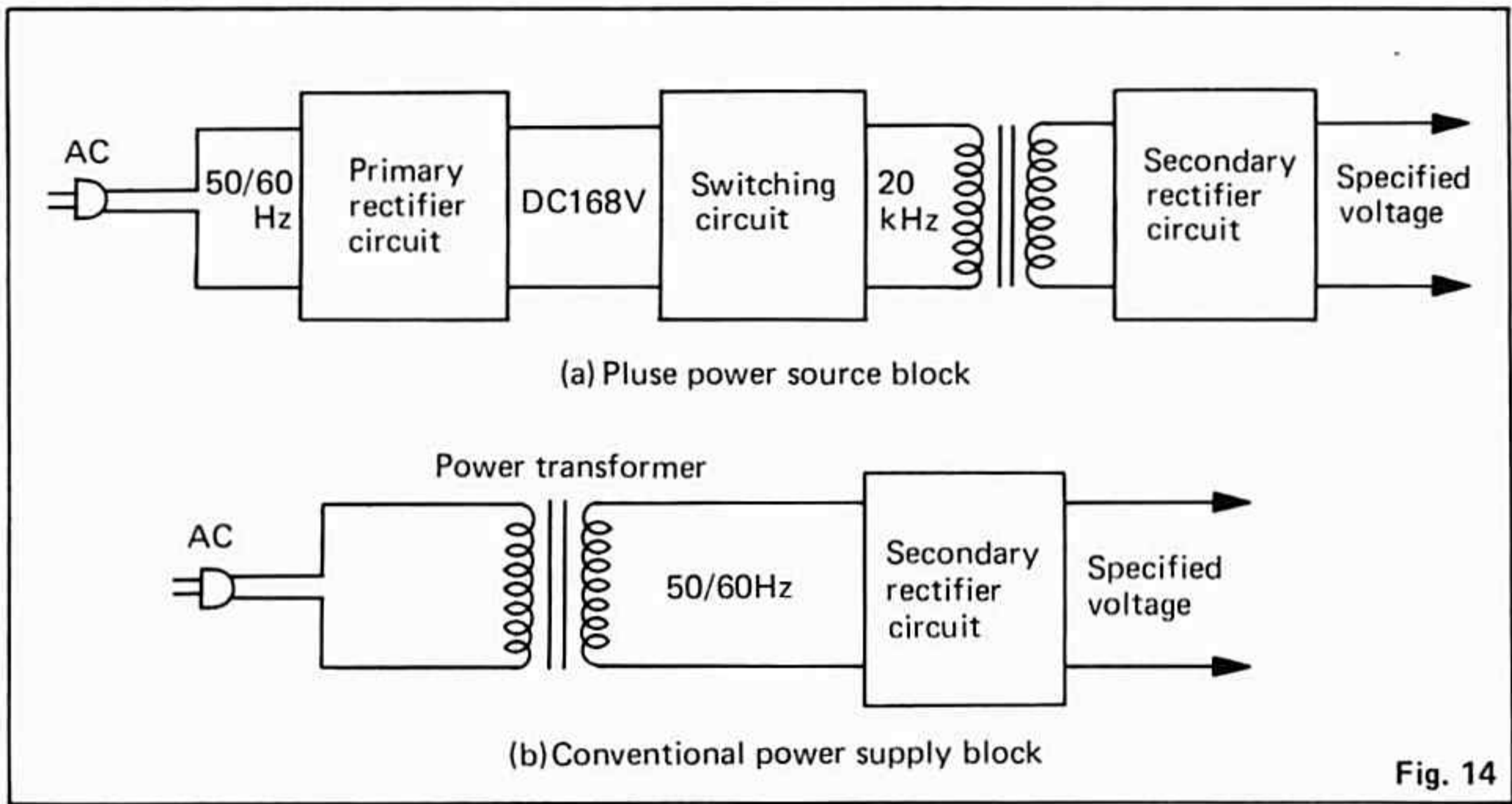

Fig. 14

• Pulse power supply circuit of SP-15

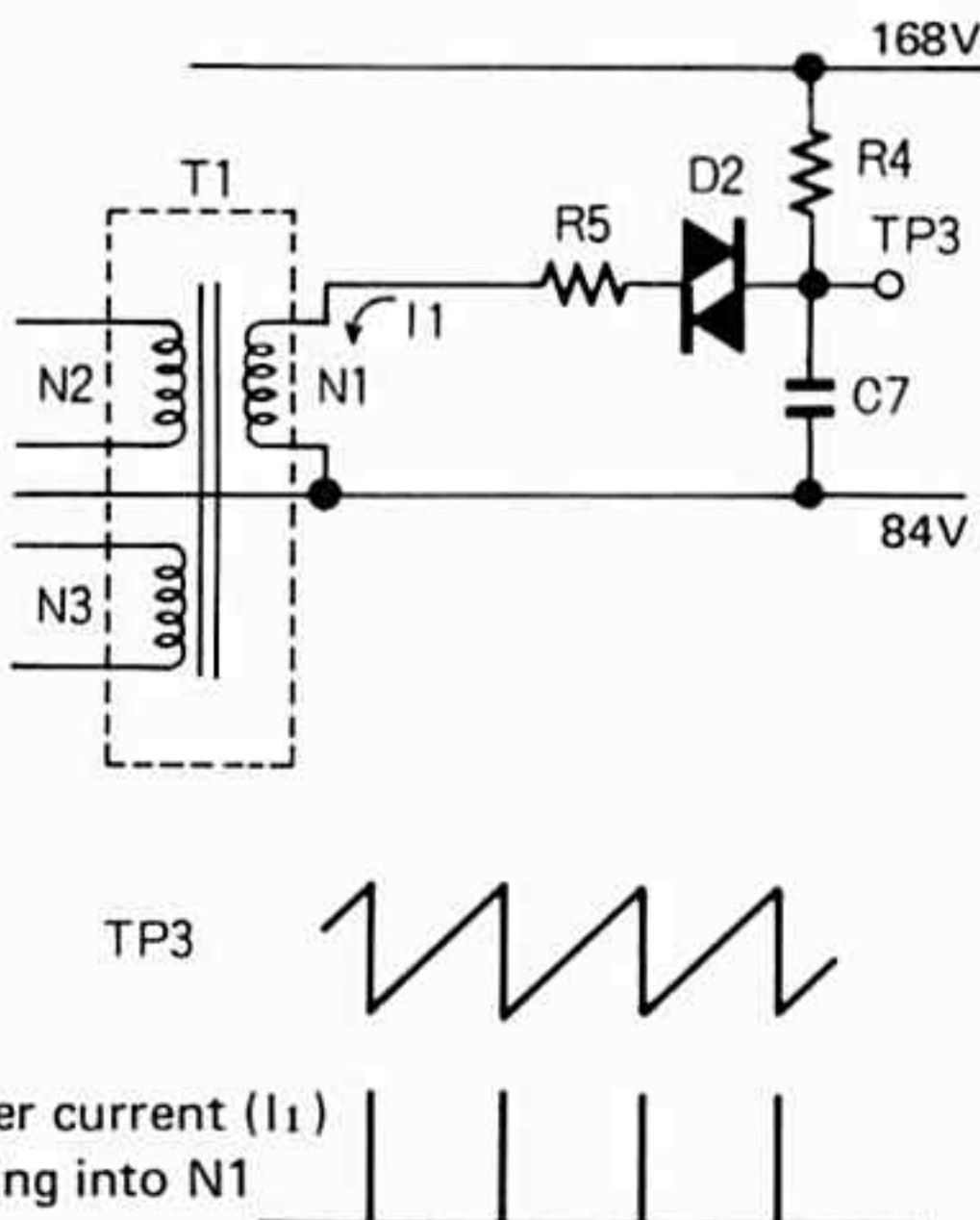

Fig. 15

1. With power supply turned ON, C7 is charged through R4. When the charged voltage becomes high enough to turn on trigger diode D2, current (I1) flows through R5. Then, C7 is discharged and, therefore, it is again charged through R4. As the operations are repeated, trigger current flows into N1 as shown in Fig. 15.

* Trigger diode

When a voltage higher than the specification is applied between terminals T1 and T2, it works to flow a current irrespective of the polarity.



• **Switching circuit operation**

- ❶ Commercial power (50/60Hz) is rectified by D1 and D4 through line filter L4 to obtain DC 168V. The DC 168V is divided by R2 and R3 so that TP. 0 = 0V, TP. 2 = 84V and TP. 3 = 168V.
- ❷ C7 is charged through R4. When trigger diode D2 reaches "on" level, the trigger current flows from D2 to N1 via R5. Since the coils of N2 and N3 are reverse in phase, when a current flows into N1 in the direction of \downarrow , the base current is generated at N2 and N3 so that Q1 and Q2 are respectively reverse- and forward-biased. Therefore, Q1 turns off and Q2 turns on, and the primary current of T2 flows from N1 \rightarrow N5 \rightarrow Q2 (C-E) \rightarrow TP. 0. At that time, a feedback current is generated at N4 and it flows into N1 through R6. The current flowing into N1 becomes of positive feedback, then Q1 and Q2 keep turning on, and the collector current of Q2 keeps increasing in accordance with the inductance of N5.
- ❸ However, N3 is directly connected between base and emitter of Q2, proximately being short-circuited, therefore, the feedback current is saturated at a given value determined by R6. Accordingly, the base current of Q2 decreases in accordance with the inductance of N3. When the base current of Q2 is about to become smaller, the counter electromotive force is generated at N1, causing the feedback current to flow in the reverse direction, and then a positive feedback line is formed for Q1. Consequently, Q1 turns on and Q2 turns off, and the primary current of T2 flows from TP. 1 \rightarrow Q1 (C-E) \rightarrow N5 \rightarrow TP. 2. Similarly, when the current is saturated, a positive feedback line is formed for Q2.
- ❹ Through repetition of the above procedure, the oscillation is continued and 20 kHz pulse voltage can be obtained at N6 on the secondary side of T2.

Fig. 16 Switching circuit
(\bullet -mark shows the polarity of coil.)

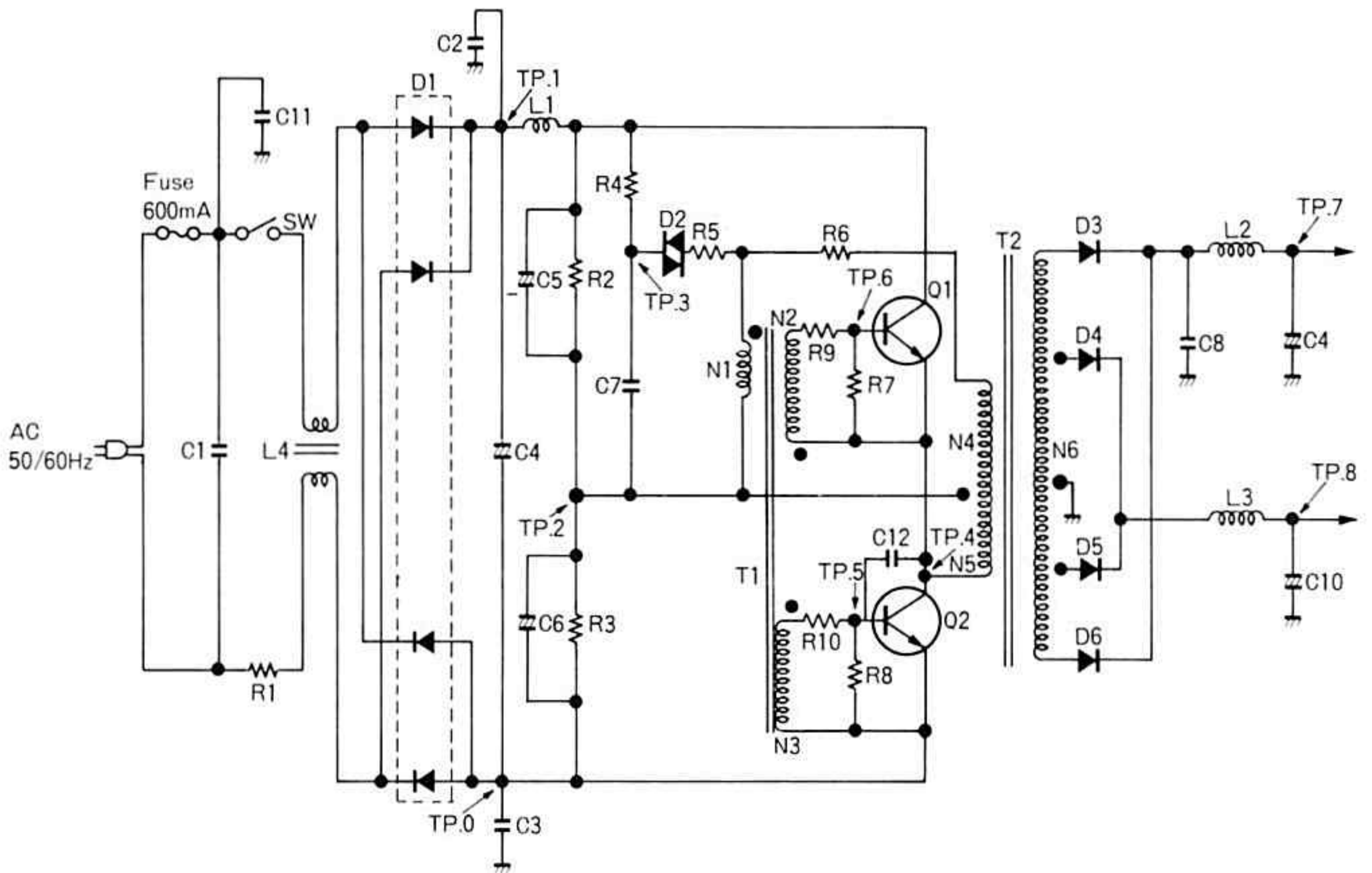

DISASSEMBLY PROCEDURE

How to remove bottom cover and shielding plate.

1. Remove the turntable rubber and turntable, and then turn the main body upside down.
2. Remove 12 setscrews of the bottom cover. (See Fig.17.)

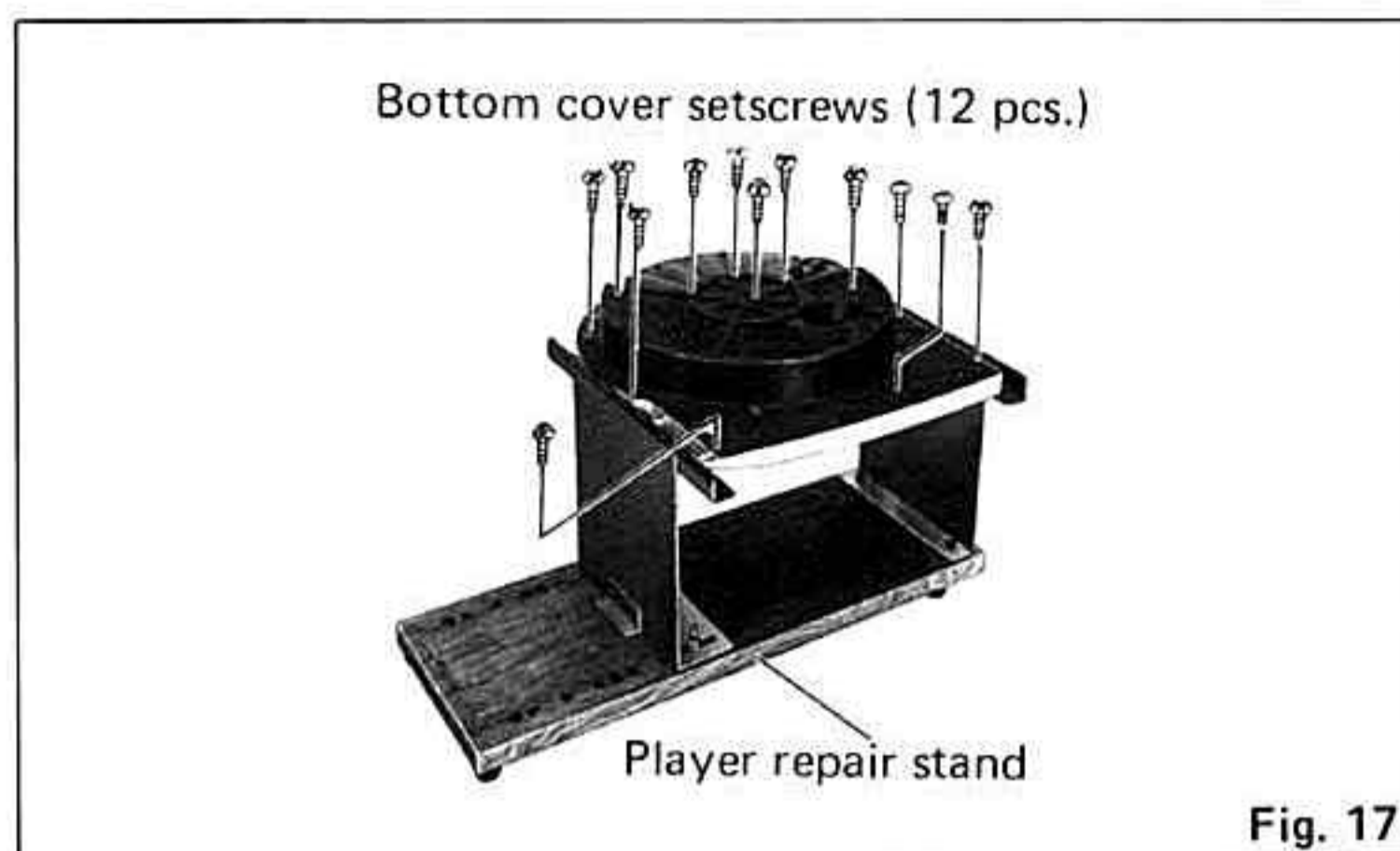

3. Remove 7 setscrews of the shielding cover. (See Fig.18.)

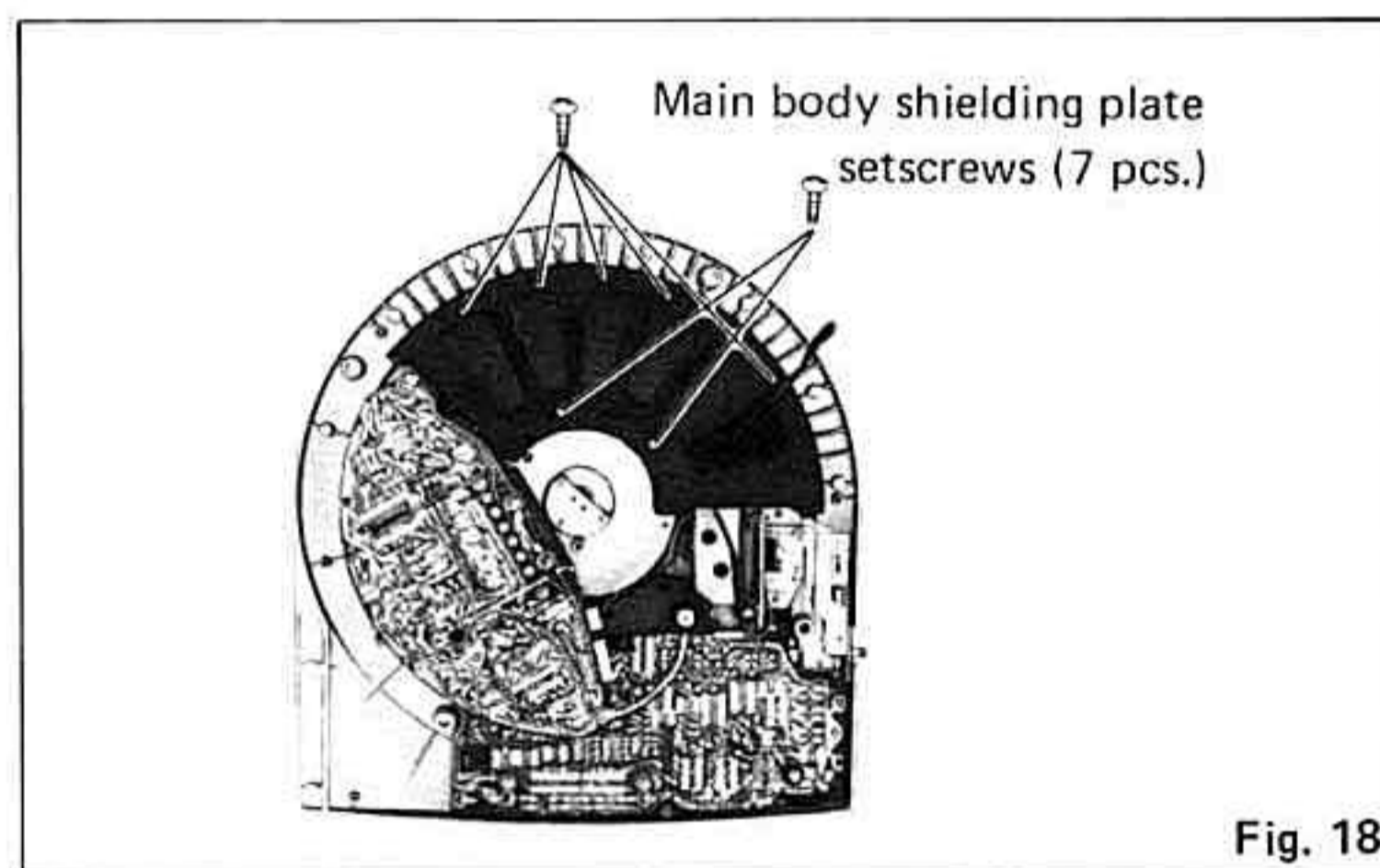

How to remove drive circuit board (See Fig.19.)

1. Detach connector A from the solenoid, and drive connector B from the logical circuit board.
2. Remove 6 setscrews of the drive circuit board.
3. Remove the drive circuit board, and detach the motor drive connector and the power line connector from the drive circuit board. Thus, the drive circuit board can be removed.

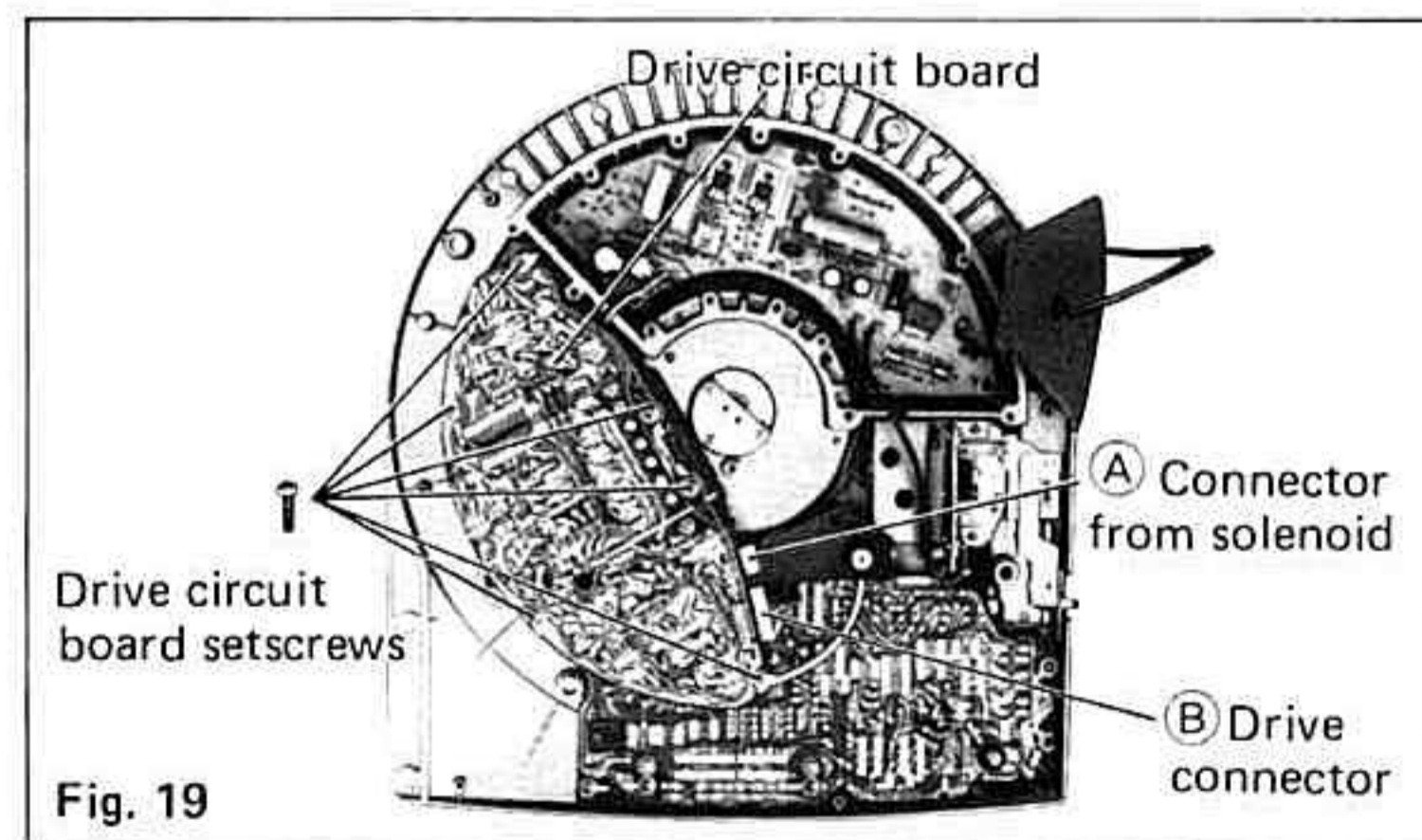

How to remove power supply circuit board and logical circuit board (See Fig.20.)

1. Remove 5 setscrews of the power supply circuit board.
Note: Take special care when disassembling the power supply section because the circuit board is supplied with a high voltage.
2. Remove 2 setscrews of the earth terminal plate.
3. Remove 7 setscrews of the logical circuit board.
4. Detach the logical circuit board and the 2P lock switch connector.

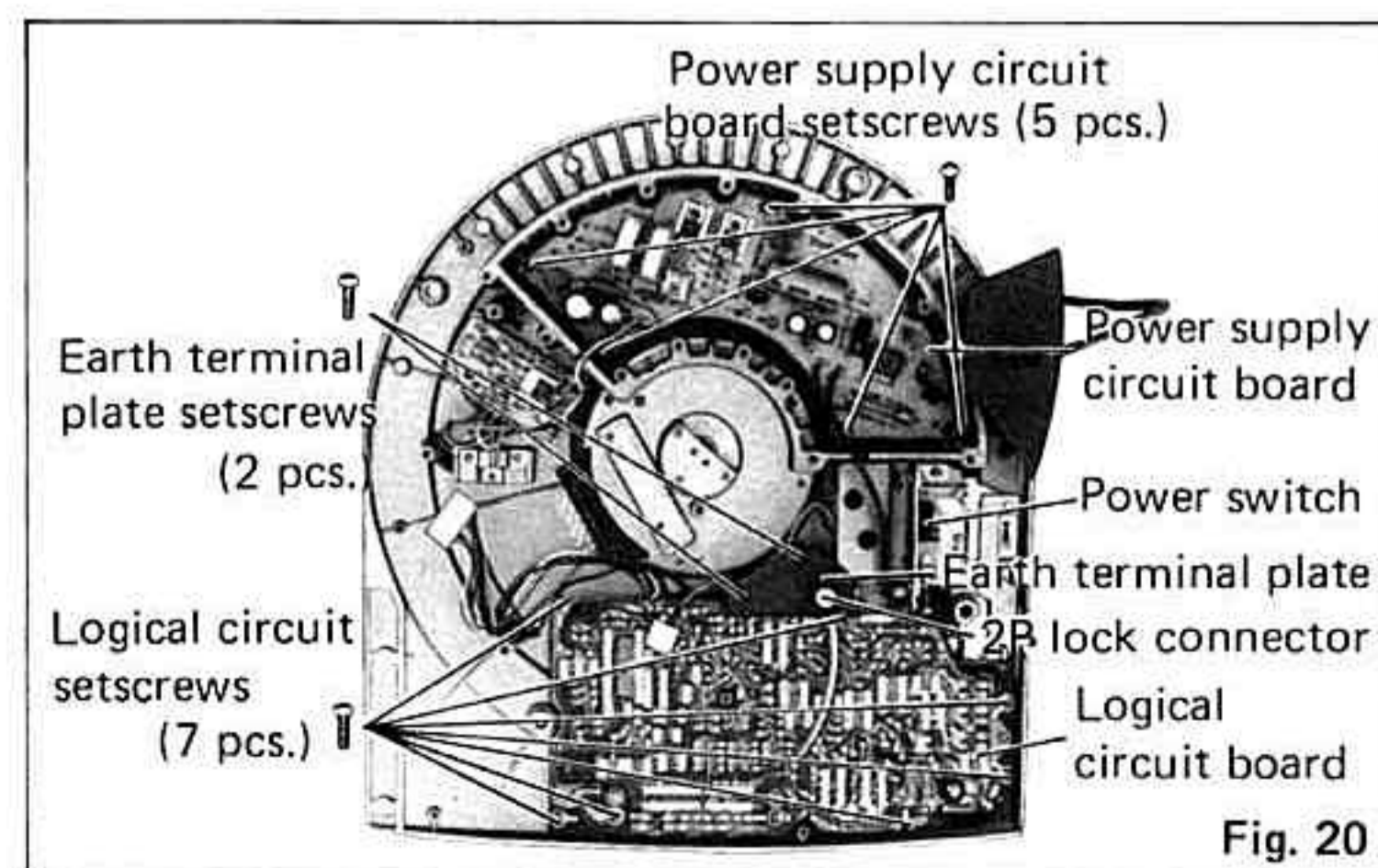

How to remove stator frame

1. Remove the drive circuit board in accordance with the above-mentioned procedure.
2. Turn the main body up and remove 3 setscrews of the stator frame. (See Fig.21.)

(marked 3 setscrews)

Remarks:

For the disassembly of mechanical parts other than the above (such as power switch plate, brake operating plate, etc.), refer to the exploded views in this manual.

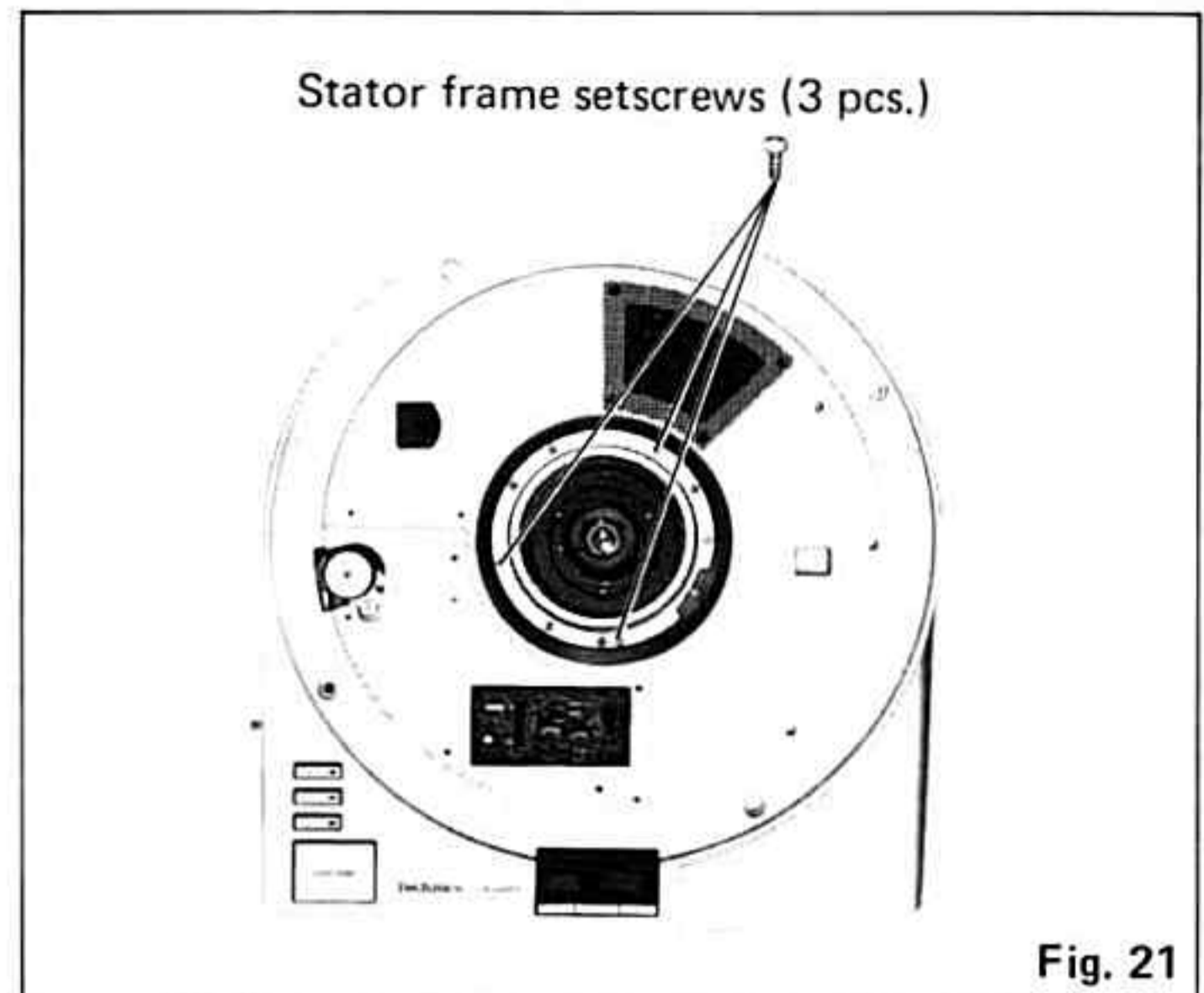

Fig. 21

Repair of drive circuit and logical circuit (Figs. 22 and 23.)

1. Detach the bottom cover with reference to the disassembly procedure.
2. Put the set on the repair stand with its front up.
3. Mount the turntable.

Then, carry out the check of each part in accordance with the Trouble Shooting Chart. Also use a stroboscope when checking the number revolutions.

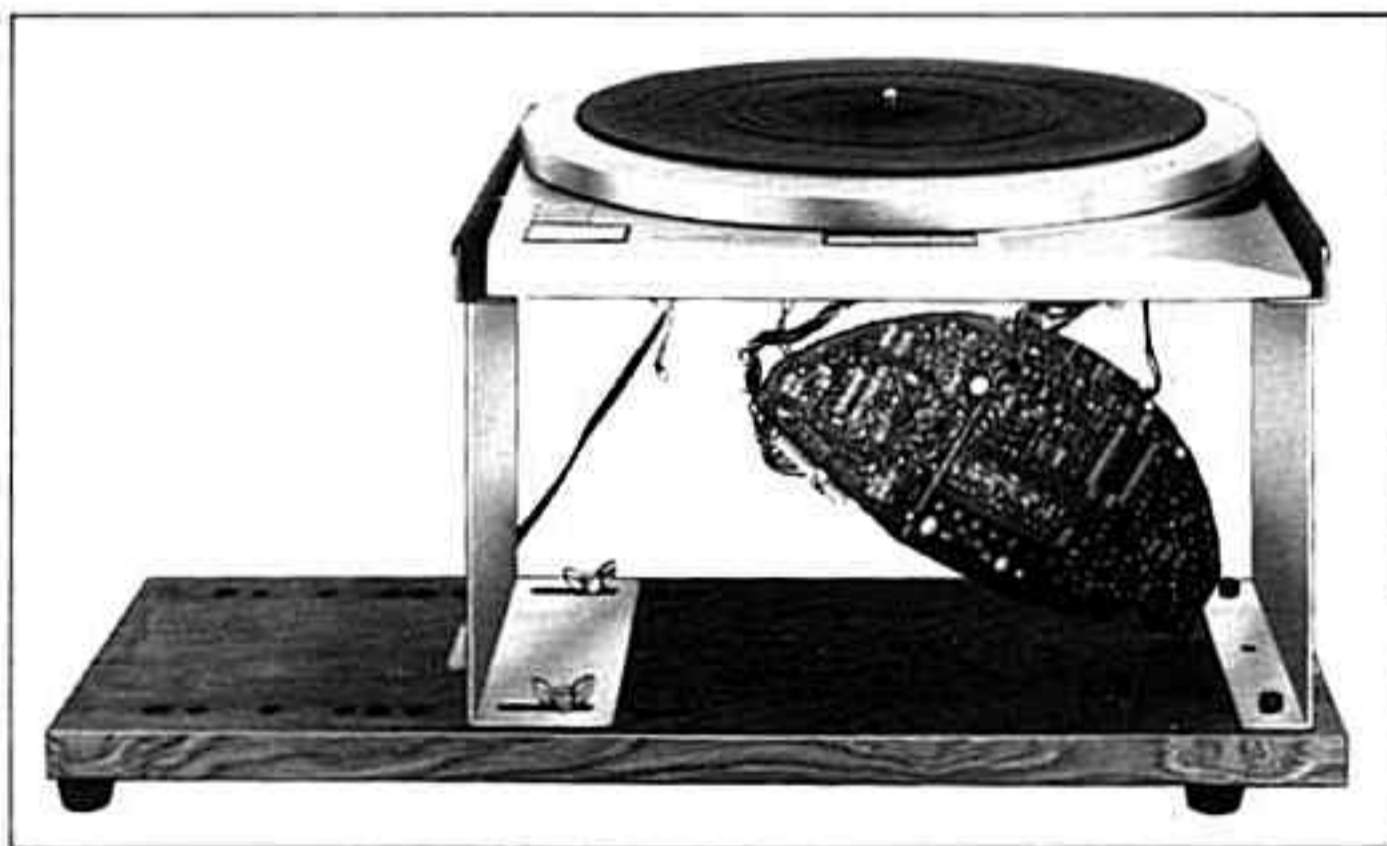

Fig. 22

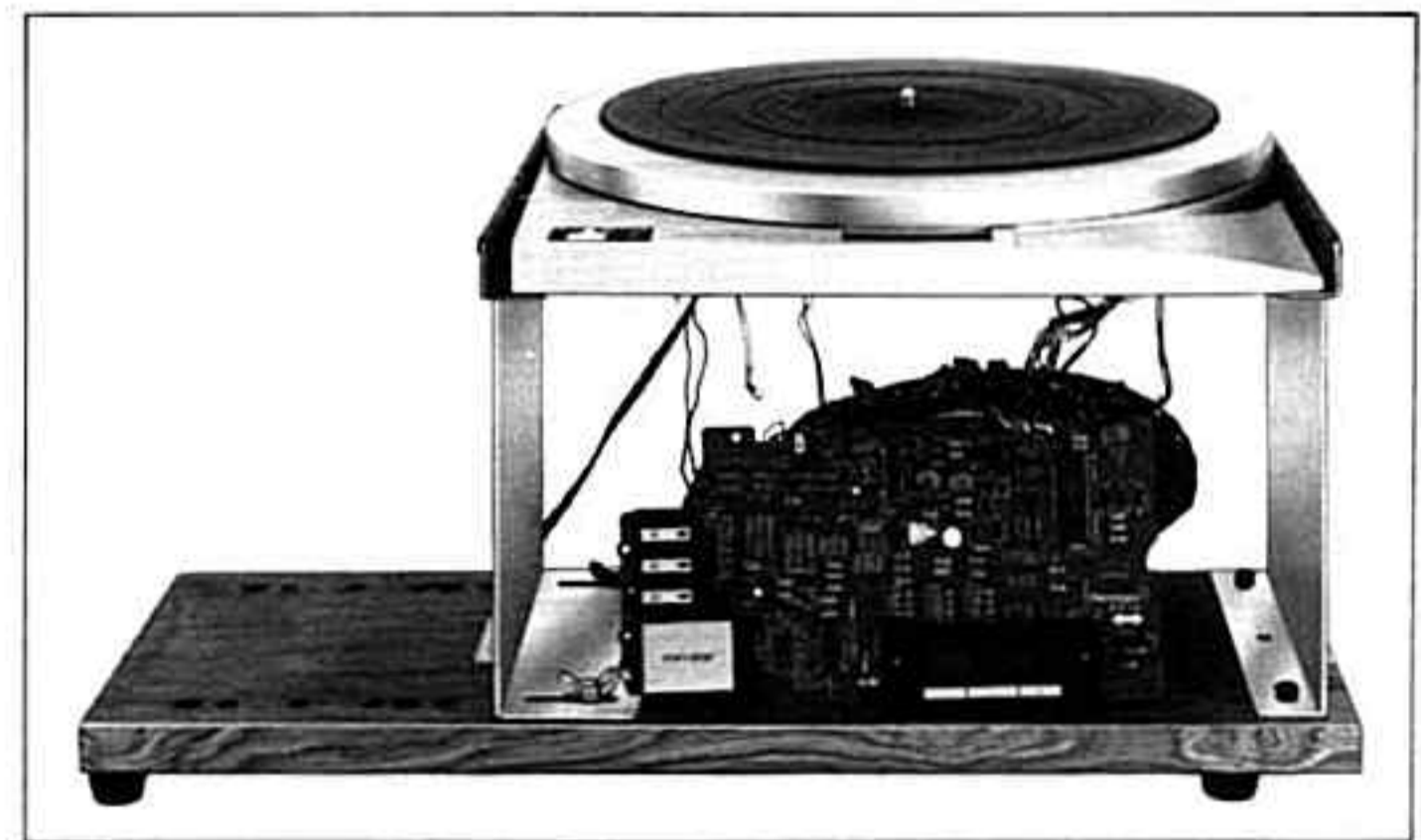

Fig. 23

Repair of power supply circuit

1. Remove the bottom cover and the shielding plate with reference to the disassembly procedure.
2. Carry out the check of each part according to the Trouble Shooting Chart with reference to the test points printed on the power supply circuit.



■ ADJUSTMENTS

Adjustment Points of Electrical System

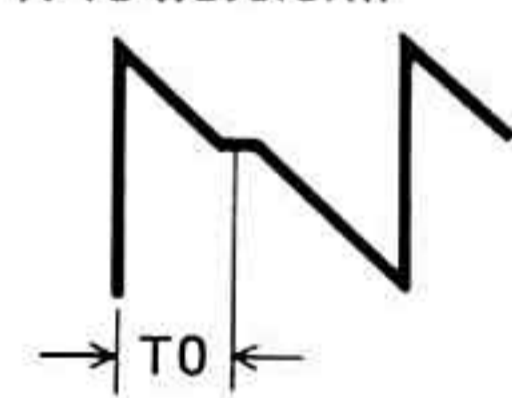
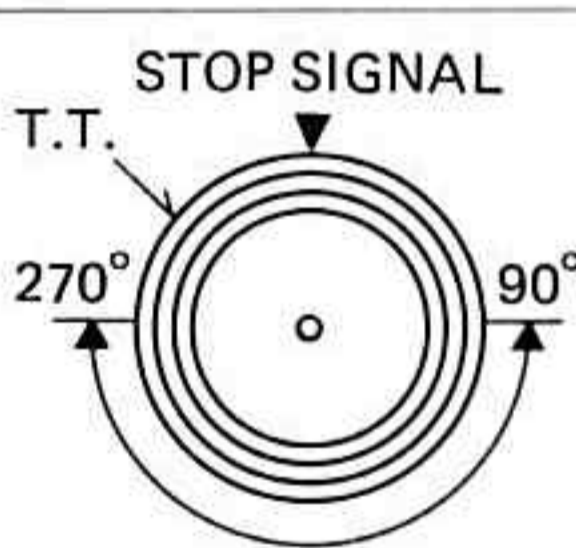
NOTE: Make the following adjustments after replacing parts such as IC's, transistors, diodes, etc.

	Adjustment	Connection Points	Adjustment Point	Adjustment Method
1	Adjustment of standard voltage (VS)	DC voltmeter or Oscilloscope ⊕ → TP18 ⊖ → GROUND	VR301	With the start switch set at ON, adjust VR301 so that the voltage is DC 2.10V ±0.01 at 33 r.p.m. Confirm that the voltage is 2.835V ±0.05V at 45 r.p.m. and 4.9V ±0.1V at 78 r.p.m.
2	Adjustment of current source (IR)	DC voltmeter or Oscilloscope ⊕ → TP19 ⊖ → TP21	VR201	Turn start switch on to begin turntable rotation. Adjust VR201 for 0 V potential difference of TP19 and TP21.
3	Tracking adjustment (TRACKING)	Oscilloscope ⊕ → TP18 ⊖ → GROUND	VR101	TP18 waveform  With the start switch set at ON, adjust VR101 so that $8 \leq T0 \leq 8.5$ ms at 33 r.p.m. Confirm that $5.8 \leq T0 \leq 6.4$ ms at 45 r.p.m. and $3 \leq T0 \leq 4.5$ ms at 78 r.p.m.
4	Braking adjustment (BRAKE)	—	VR202	 Adjust VR202 for complete stop within 90° ~ 270° after stop signal initiated. (Turntable becomes free a few seconds after stop.)

■ TERMINAL GUIDE OF TRANSISTOR AND IC

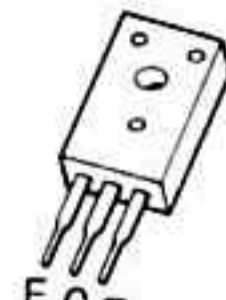
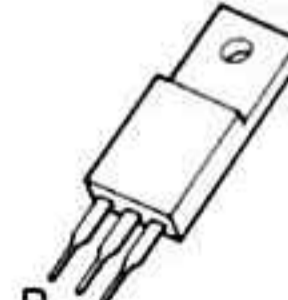
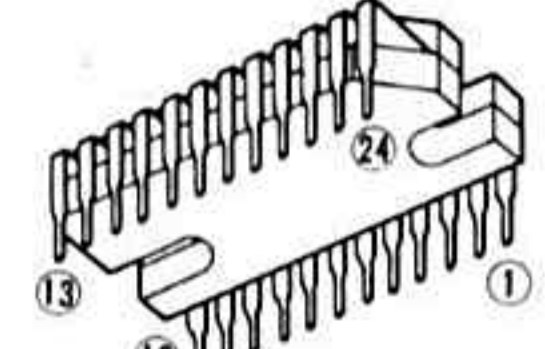
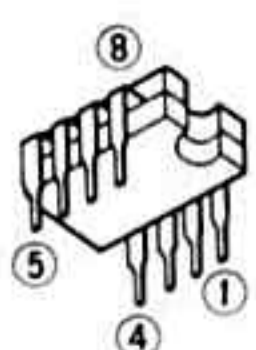
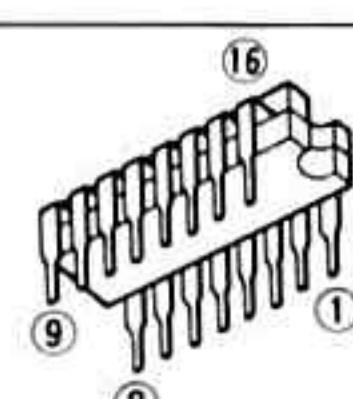
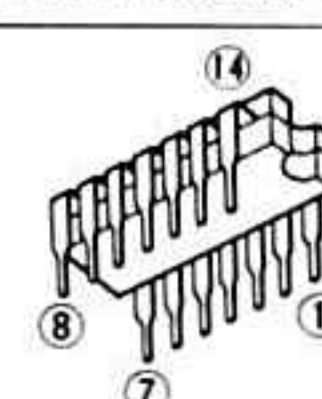
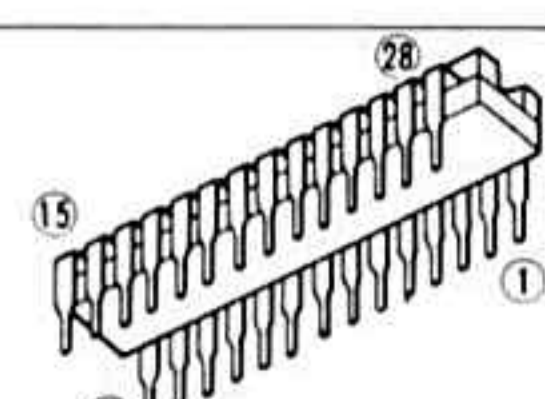
2SD636, 2SD639 2SB641, 2SB643	2SD592, 2SC828A 2SC1383	2SC1846, 2SA886 2SC1847	2SD712A-C 2SC1826	AN640G
				
SVIUPC4558C	AN660, DN860	SVIMSM4013 SVIM53217P	MN6042	
				

• **After-repair precautions**

After completion of the repair, install the main body shielding plate and the bottom cover with special care. If their installation is incomplete, the AM broadcast or the cartridge will be interfered with noise because the power supply circuit uses 20 kHz for switching. In addition, the equipment should be carefully handled as it is supplied with a high voltage.

■ **ADJUSTMENT OF MECHANICAL BRAKE**

The mechanical brake has been already factory-adjusted before delivery. However, if the brake creates abnormal noise during operation or fails to work as specified, make its adjustment in accordance with the following procedure.

- ① Remove the turntable and the main body cover.
(Refer to the exploded views.)
 - ② Loosen the screw **A** and put the turntable in place.
 - ③ Turn on the power switch and then regulate adjust screw **B** through the hole in the turntable so that the brake shoe is about 1 mm off the turntable being released while turning on and off the start/stop switch. After that, tighten the screw **A** completely.
- The above procedure is enough to complete the adjustment of the brake operating position. But if the brake shoe is worn out, loosen the screw **C** and properly shift the brake shoe.

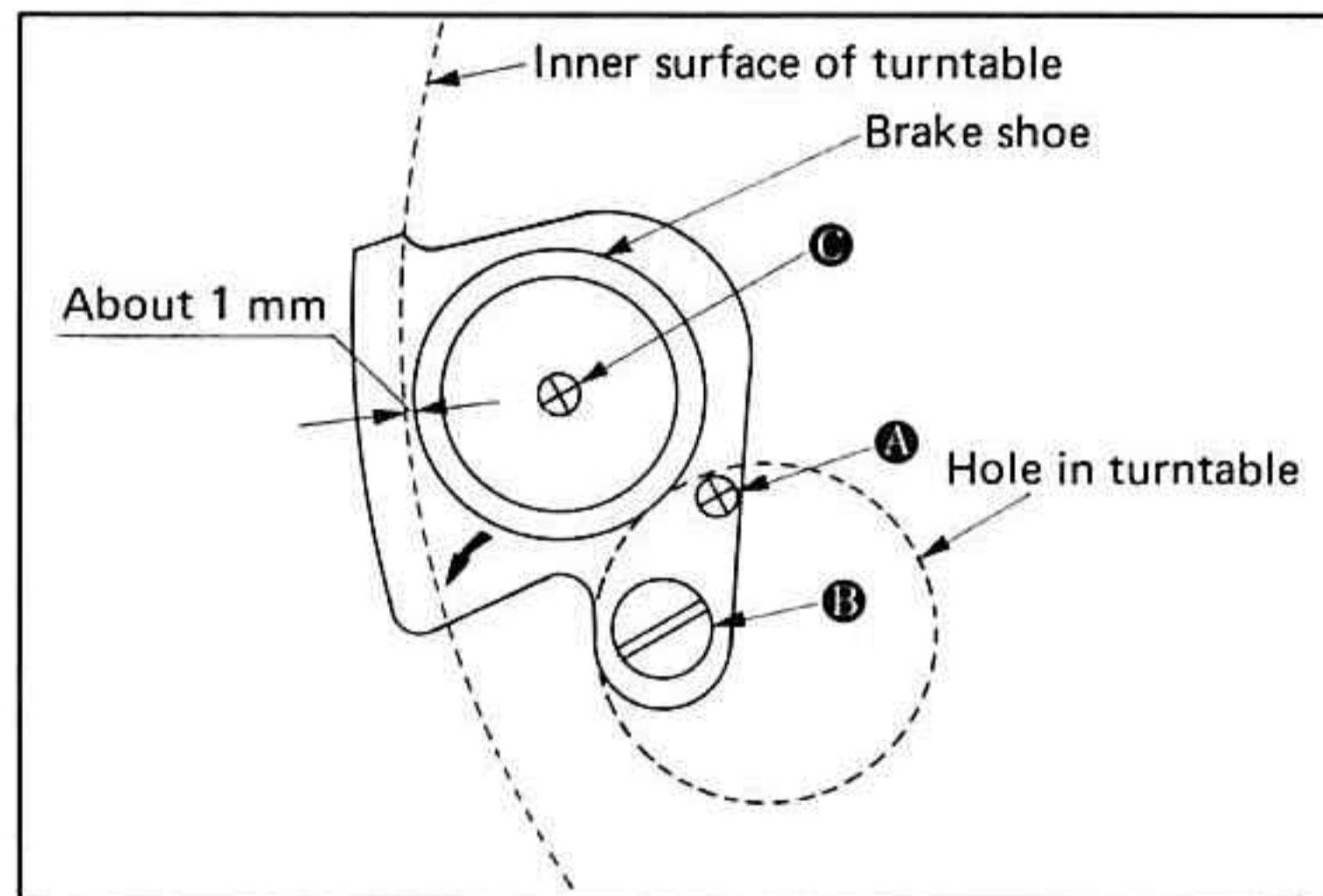
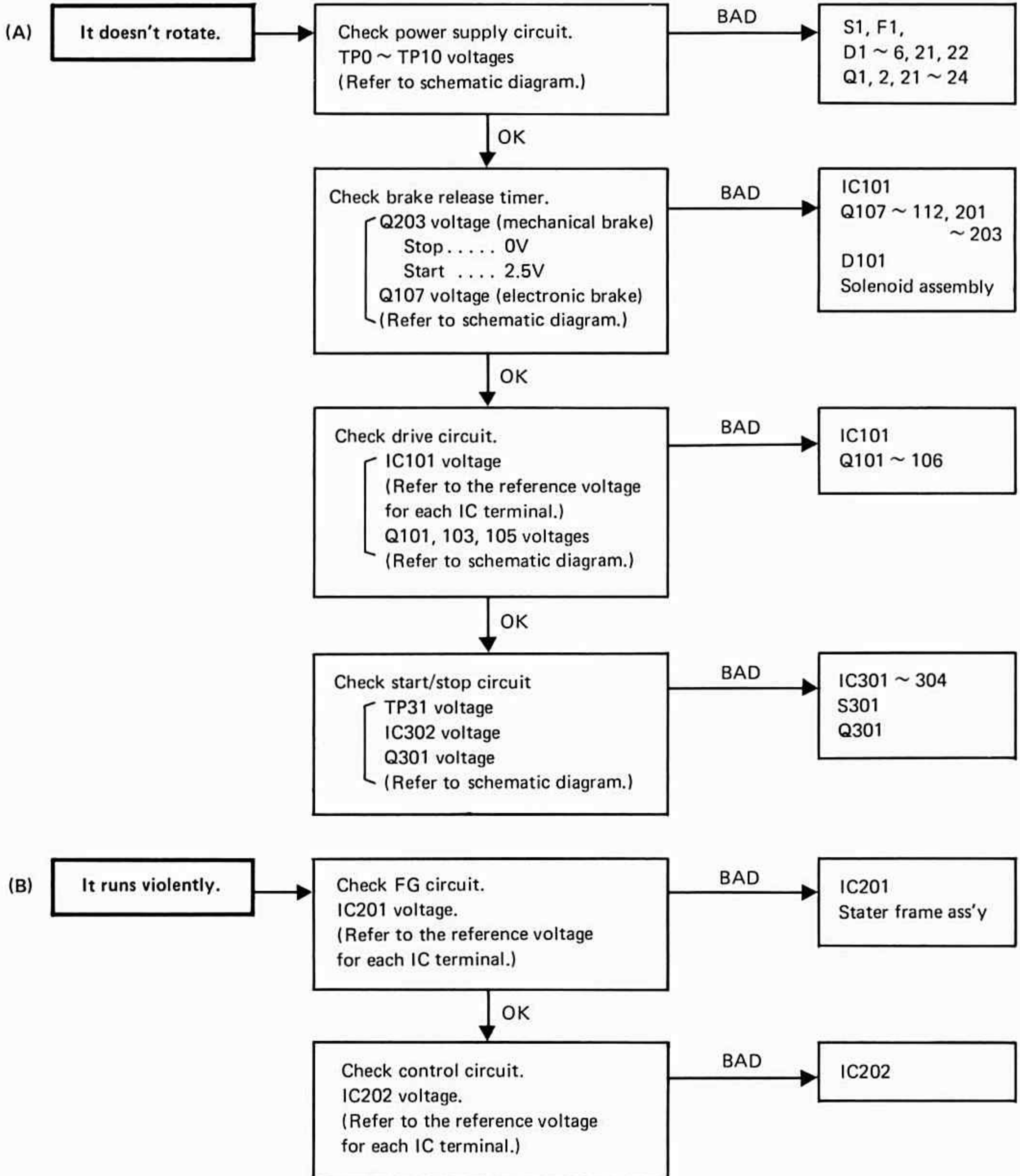
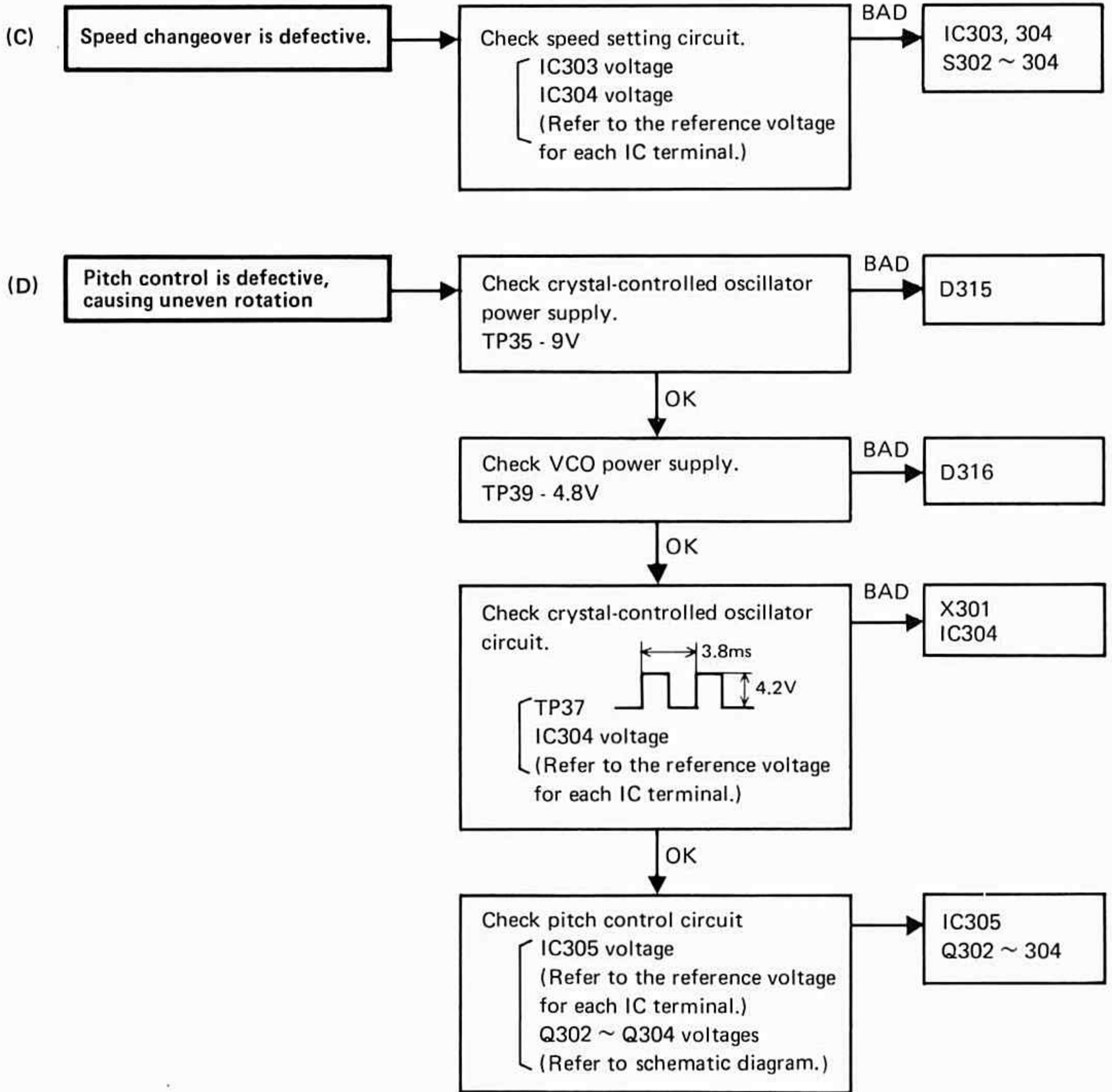

Fig. 24 Mechanical brake system

■ TROUBLE SHOOTING





■ BLOCK DIAGRAM

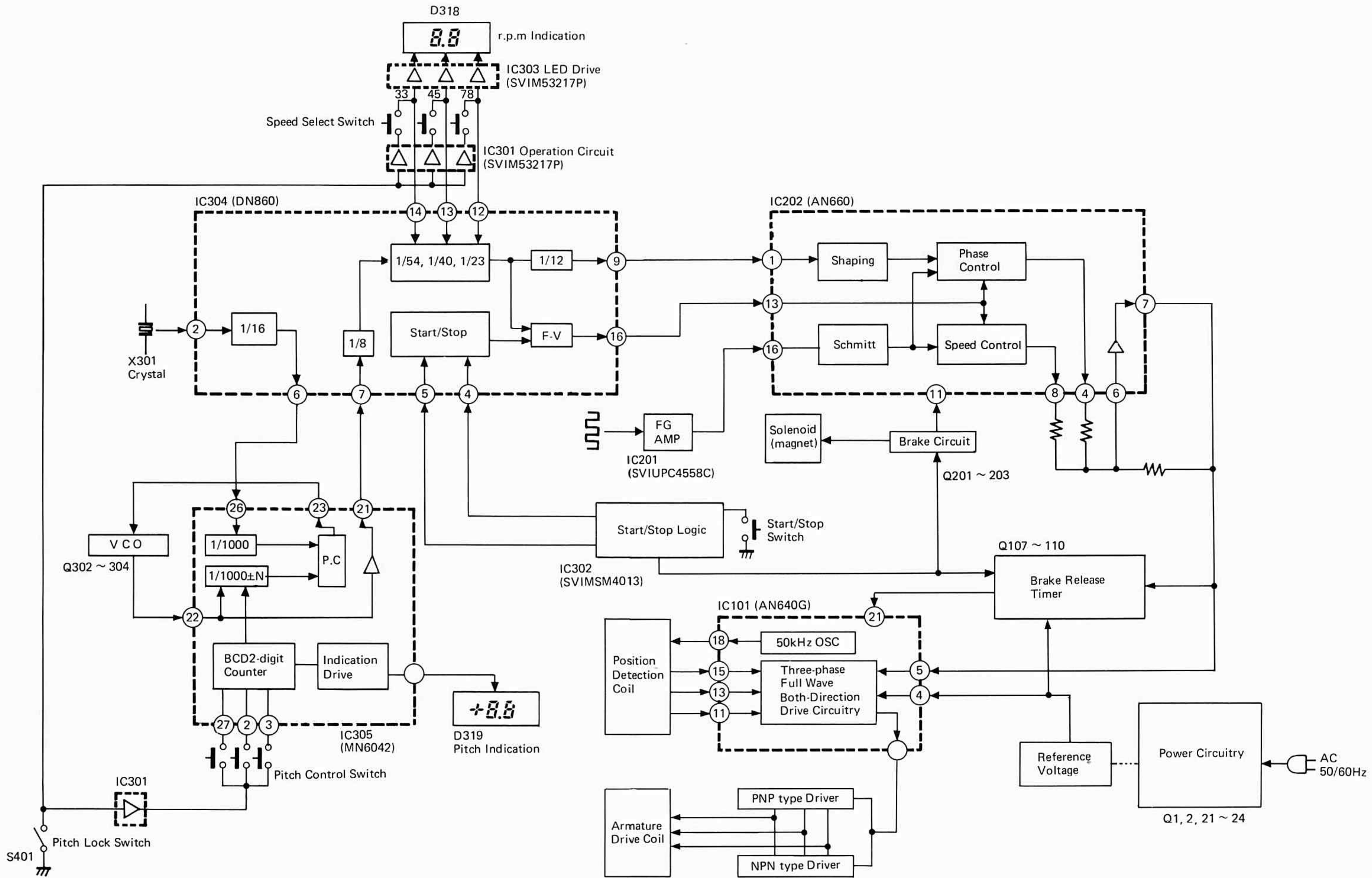

Printed Circuit Board

(Drive Circuit)

⊗ B Lines
 Earth (Ground) Lines

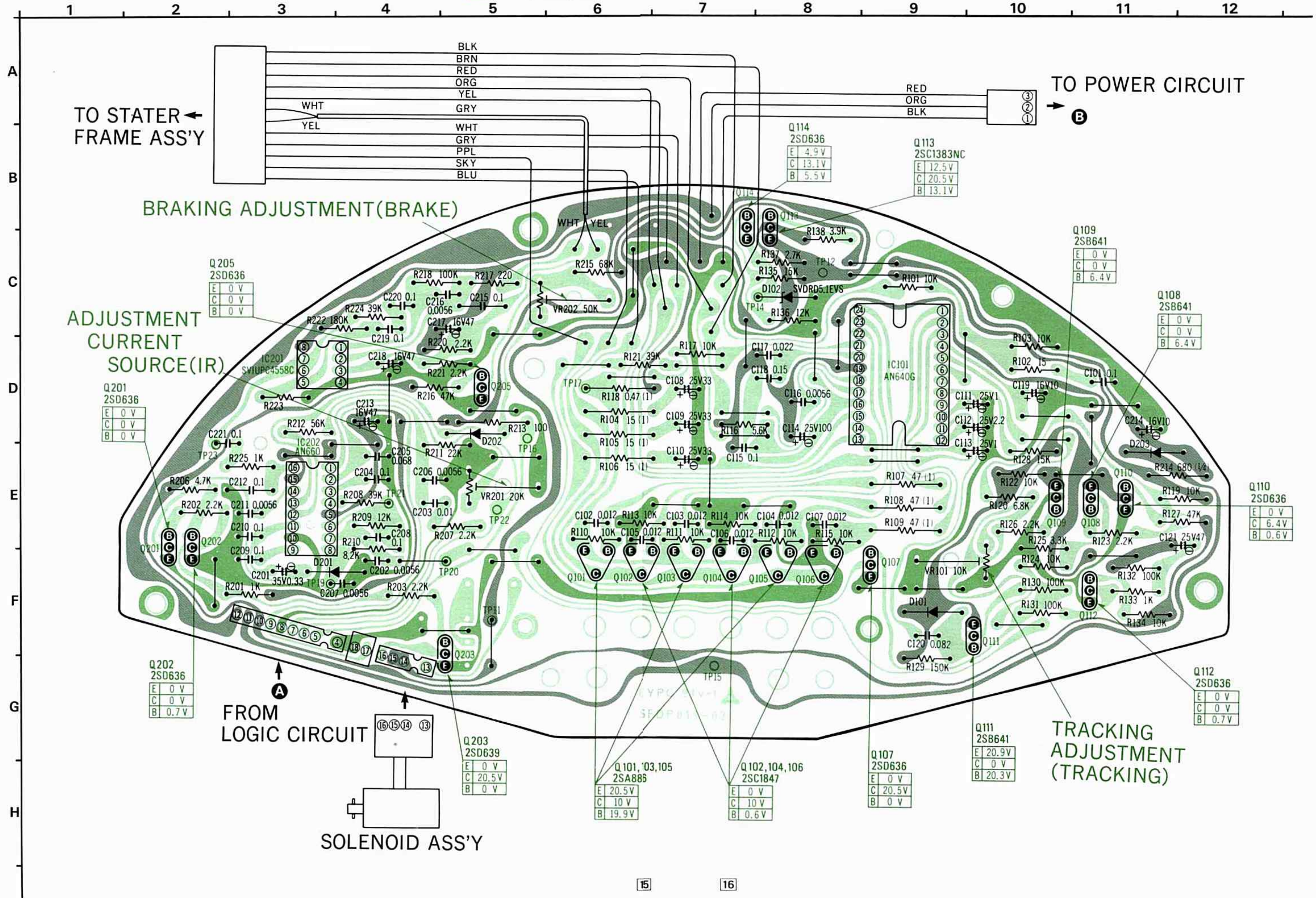

Printed Circuit Board

SP-15 SP-15

(Logic Circuit)

⊕ B Lines
 Earth (Ground) Lines

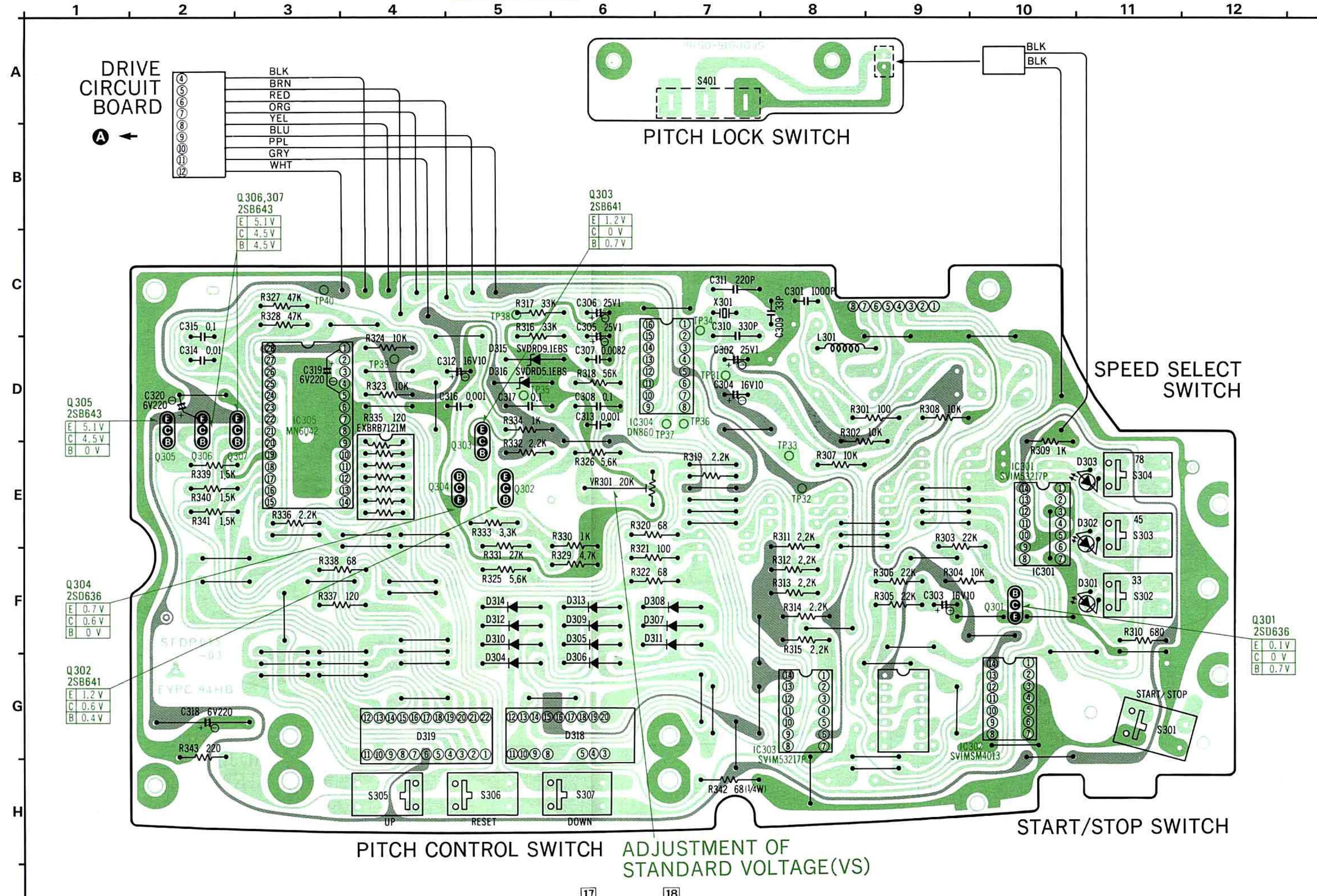

PITCH CONTROL SWITCH ADJUSTMENT OF STANDARD VOLTAGE (VS)

Printed Circuit Board

(Power Circuit)

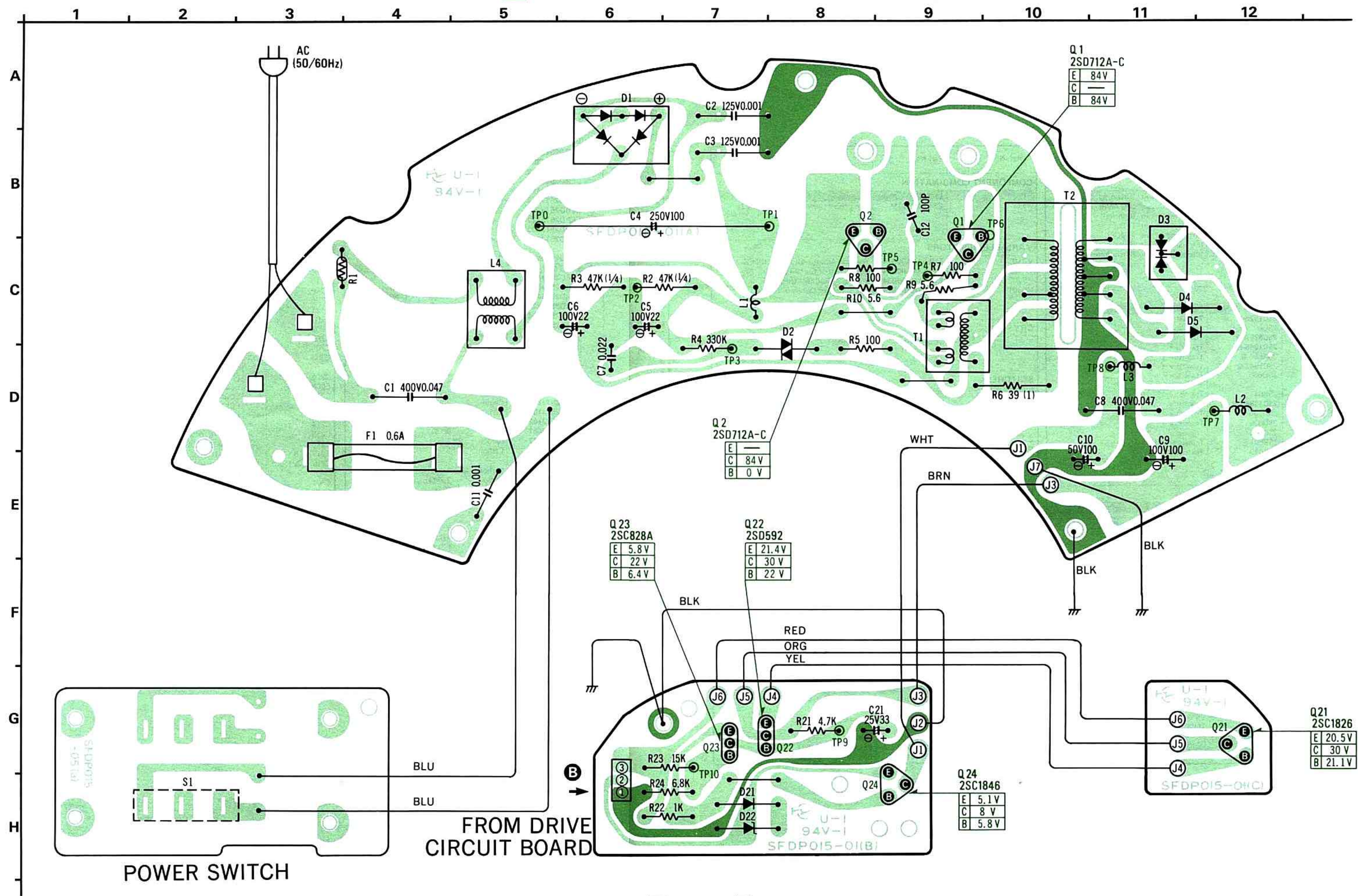

Earth (Ground) Lines

1 2 3 4 5 6 7 8 9 10 11 12

A

B

C

D

E

F

G

H

AC
(50/60Hz)

Q1	2SD712A-C
E	84V
C	—
B	84V

Q2	2SD712A-C
E	—
C	84V
B	0V

Q23	2SC828A
E	5.8V
C	22V
B	6.4V

Q22	2SD592
E	21.4V
C	30V
B	22V

Q21	2SC1826
E	20.5V
C	30V
B	21.1V

Q24	2SC1846
E	5.1V
C	8V
B	5.8V

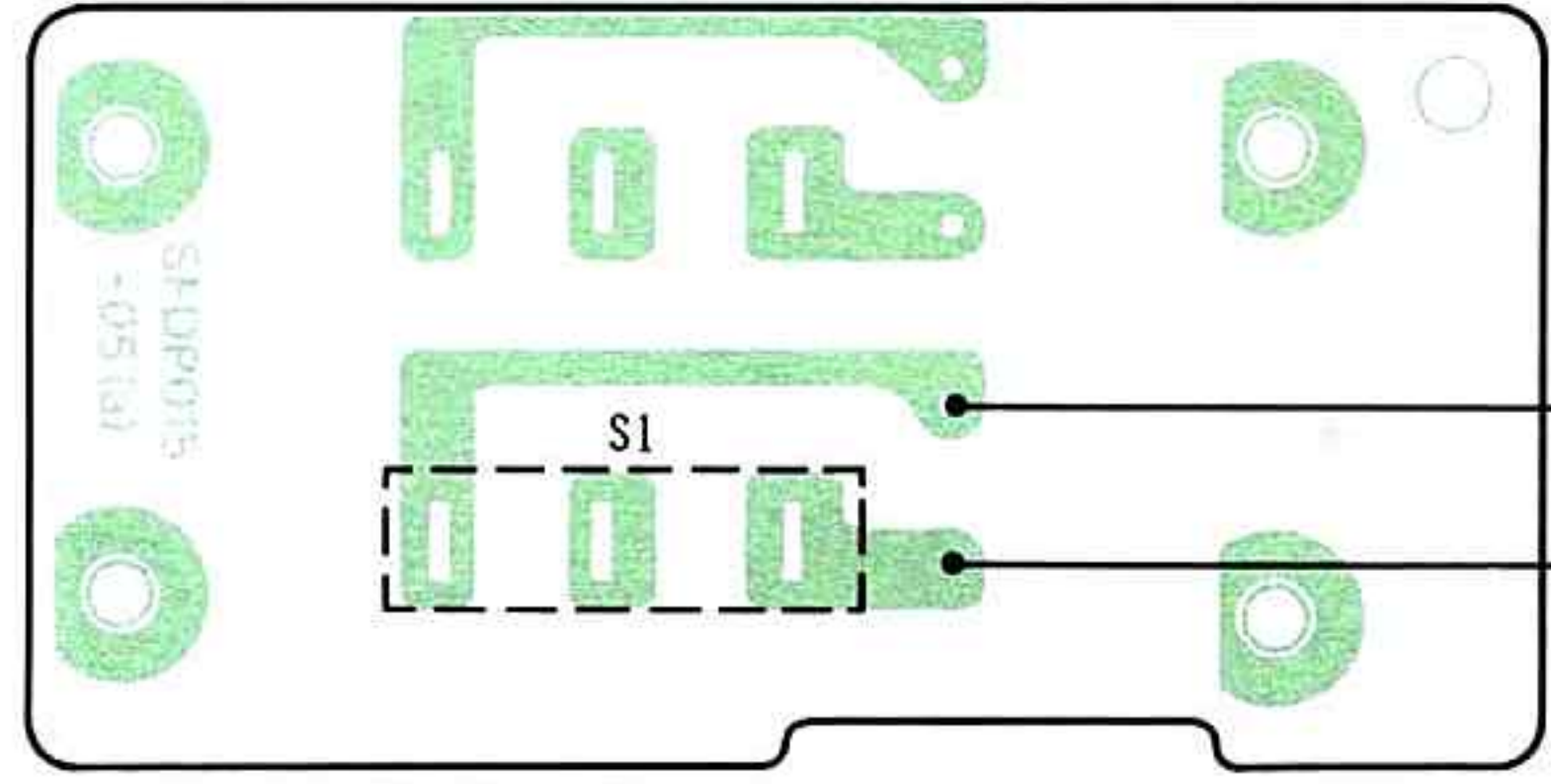

POWER SWITCH

FROM DRIVE
CIRCUIT BOARD

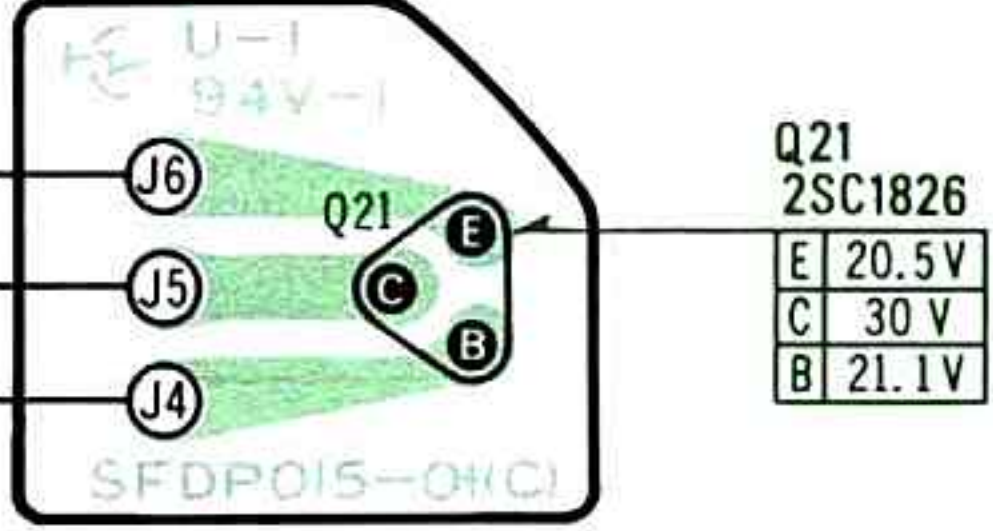
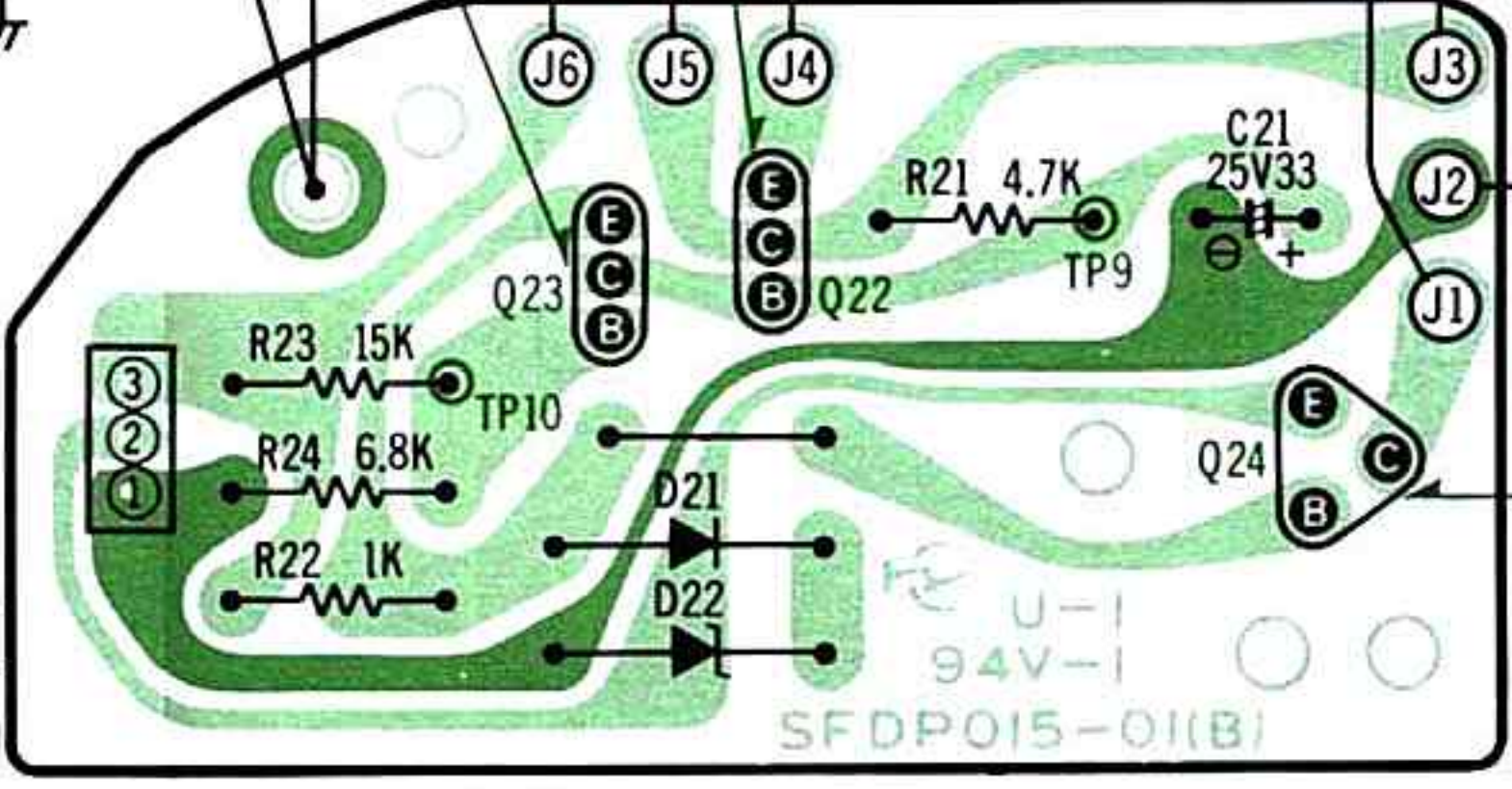

WHT
BRN
BLK
BLK

BLK

RED
ORG
YEL

BLU

BLU

B

REPLACEMENT PARTS LIST

Important Safety Notice

Components identified by shaded area have special characteristics important for safety. When replacing any of these components use only manufacturer's specified parts.

- Notes:** 1. Part numbers are indicated on most mechanical parts. Please use this part number for parts orders.
2. SP-15 (M) → [M], SP-15 (MC) → [MC].

Ref. No.	Part No.	Part Name & Description
INTEGRATED CIRCUITS		
IC101	AN640G	Integrated Circuit (Drive)
IC201	SVIUPC4558C	Integrated Circuit (FG AMP)
IC202	AN660	Integrated Circuit (Control)
IC301, 303	SVIM53217P	Integrated Circuit (TTL)
IC302	SVIMSM4013	Integrated Circuit (CMOS)
IC304	DN860	Integrated Circuit (Frequency Divider)
IC305	MN6042	Integrated Circuit (Pitch Control)
TRANSISTORS		
Q1, 2	2SD712A-C	Transistor
Q21	2SC1826-Y	Transistor
Q22	2SD592AE-R	Transistor
Q23	2SC828A-R	Transistor
Q24	2SC1846-R	Transistor
Q101, 103, 105	2SA886-Q	Transistor
Q102, 104, 106	2SC1847-Q	Transistor
Q107, 110, 112, 114	2SD636	Transistor
Q108, 109, 111	2SB641	Transistor
Q113	2SC1384A-R	Transistor
Q201, 202, 205	2SD636	Transistor
Q203	2SD639	Transistor
Q301, 304	2SD636	Transistor
Q302, 303	2SB641	Transistor
Q305, 306, 307	2SB643	Transistor
} Use pair ranks		
DIODES		
D1	SVDS1RBA40	Rectifier
D2	SVDS1S2093	Diode
D3	SVDCTU22S	Diode
D4, 5	SVDV19C	Diode
D201, 101, 201, 202, 203	MA150	Diode
D22, 102	SVDRD5.1EBS	Diode, Zener 5.1V
D301, 302, 303	SVDSR105C	Light Emitting Diode
D304 ~ 314	MA150	Diode
D315	SVDRD9.1EBS	Diode, Zener 9.1V
D316	SVDRD5.1EBS	Diode, Zener 5.1V
D318	SVDGL7R204	Diode, rpm Indication
D319	SVDGL7R203	Diode, Pitch Indication
D320	SVDIS1887	Diode, Solenoid
COILS and TRANSFORMERS		
L1	SLQ1025T-201	Coil
L2	SLQ1016D-800	Coil
L3	SLQ809D-300	Coil
L4	ELF18D305	Filter
L301	SLQ0406S102K	Transformer
T1	SLT12K6A	Transformer
T2	SLT25K3A	Chock Coil

Ref. No.	Part No.	Part Name & Description
COMPONENT COMBINATION		
R1	ERTD3FEK8R0S	Thermistor
R335	EXBRB7121M	Component Combination (120Ω x 7)
VARIABLE RESISTORS		
VR101	EVLS3AA00B14	Tracking Adjustment (TRACKING)
VR201	EVLS3AA00B24	Adjustment of Current Source (IR)
VR202	EVLS3AA00B54	Braking Adjustment (BRAKE)
VR301	EVLS3AA00B24	Adjustment of Standard Voltage (VS)
CRYSTAL		
X301	SVQU306115	4.19328MHz Oscillator
SWITCHES		
S1	SFDSSS5GL132	Switch, Power
S301 ~ 307	EVQP1R04K	Switch
S401	SFDSSS5GL13C	Switch, Pitch Lock
FUSE		
F1	XBA2F06NU100	Fuse, 0.6A
RESISTORS		
R2, 3	ERD25TJ473	Carbon, 47kΩ, 1/4W, ± 5%
R4	ERD25TJ334	Carbon, 330kΩ, 1/4W, ± 5%
R5	ERD25TJ101	Carbon, 100Ω, 1/4W, ± 5%
R6	ERG1ANJ330	Metallic, 33Ω, 1W, ± 5%
R7, 8	ERD25TJ101	Carbon, 100Ω, 1/4W, ± 5%
R9, 10	ERD25TJ5R6	Carbon, 5.6Ω, 1/4W, ± 5%
R21	ERD25TJ472	Carbon, 4.7kΩ, 1/4W, ± 5%
R22	ERD25TJ102	Carbon, 1kΩ, 1/4W, ± 5%
R23	ERD25TJ153	Carbon, 15kΩ, 1/4W, ± 5%
R24	ERD25TJ682	Carbon, 6.8kΩ, 1/4W, ± 5%
R101	ERD25TJ103	Carbon, 10kΩ, 1/4W, ± 5%
R102	ERD25TJ150	Carbon, 15Ω, 1/4W, ± 5%
R103	ERD25TJ103	Carbon, 10kΩ, 1/4W, ± 5%
R104 ~ 106	ERG1ANJP150	Metallic, 15Ω, 1W, ± 5%
R107 ~ 109	ERG1ANJP470	Metallic, 47Ω, 1W, ± 5%
R110 ~ 115	ERD25TJ103	Carbon, 10kΩ, 1/4W, ± 5%
R116	ERD25TJ562	Carbon, 5.6kΩ, 1/4W, ± 5%
R117	ERD25TJ103	Carbon, 10kΩ, 1/4W, ± 5%
R118	ERX1ANJPR47	Metallic, 0.47Ω, 1W, ± 5%
R119	ERD25TJ103	Carbon, 10kΩ, 1/4W, ± 5%
R120	ERD25TJ682	Carbon, 6.8kΩ, 1/4W, ± 5%
R121	ERD25TJ393	Carbon, 39kΩ, 1/4W, ± 5%
R122	ERD25TJ103	Carbon, 10kΩ, 1/4W, ± 5%
R123	ERD25TJ222	Carbon, 2.2kΩ, 1/4W, ± 5%
R124	ERD25TJ103	Carbon, 10kΩ, 1/4W, ± 5%

Ref. No.	Part No.	Part Name & Description
R125	ERD25TJ332	Carbon, 3.3kΩ, 1/4W, ± 5%
R126	ERD25TJ222	Carbon, 2.2kΩ, 1/4W, ± 5%
R127	ERD25TJ473	Carbon, 47kΩ, 1/4W, ± 5%
R128	ERD25TJ153	Carbon, 15kΩ, 1/4W, ± 5%
R129	ERD25TJ154	Carbon, 150kΩ, 1/4W, ± 5%
R130 ~ 132	ERD25TJ104	Carbon, 100kΩ, 1/4W, ± 5%
R133	ERD25TJ102	Carbon, 1kΩ, 1/4W, ± 5%
R134	ERD25TJ103	Carbon, 10kΩ, 1/4W, ± 5%
R135	ERD25TJ153	Carbon, 15kΩ, 1/4W, ± 5%
R136	ERD25TJ123	Carbon, 12kΩ, 1/4W, ± 5%
R137	ERD25TJ272	Carbon, 2.7kΩ, 1/4W, ± 5%
R138	ERD25TJ392	Carbon, 3.9kΩ, 1/4W, ± 5%
R201	ERD25TJ102	Carbon, 1kΩ, 1/4W, ± 5%
R202, 203	ERD25TJ222	Carbon, 2.2kΩ, 1/4W, ± 5%
R206	ERD25TJ472	Carbon, 4.7kΩ, 1/4W, ± 5%
R207	ERD25TJ222	Carbon, 2.2kΩ, 1/4W, ± 5%
R208	ERD25TJ393	Carbon, 39kΩ, 1/4W, ± 5%
R209	ERD25TJ123	Carbon, 12kΩ, 1/4W, ± 5%
R210	ERD25TJ822	Carbon, 8.2kΩ, 1/4W, ± 5%
R211	ERD25TJ223	Carbon, 22kΩ, 1/4W, ± 5%
R212	ERD25TJ563	Carbon, 56kΩ, 1/4W, ± 5%
R213	ERG1ANJ101	Metallic, 100Ω, 1W, ± 5%
R214	ERD25TJ681	Carbon, 680Ω, 1/4W, ± 5%
R215	ERD25TJ683	Carbon, 68kΩ, 1/4W, ± 5%
R216	ERD25TJ473	Carbon, 47kΩ, 1/4W, ± 5%
R217	ERD25TJ221	Carbon, 220Ω, 1/4W, ± 5%
R218	ERD25TJ104	Carbon, 100kΩ, 1/4W, ± 5%
R220, 221	ERD25TJ222	Carbon, 2.2kΩ, 1/4W, ± 5%
R222, 223	ERD25TJ184	Carbon, 180kΩ, 1/4W, ± 5%
R224	ERD25TJ393	Carbon, 39kΩ, 1/4W, ± 5%
R301	ERD25TJ101	Carbon, 100Ω, 1/4W, ± 5%
R302	ERD25TJ103	Carbon, 10kΩ, 1/4W, ± 5%
R303	ERD25TJ223	Carbon, 22kΩ, 1/4W, ± 5%
R304	ERD25TJ103	Carbon, 10kΩ, 1/4W, ± 5%
R305, 306	ERD25TJ223	Carbon, 22kΩ, 1/4W, ± 5%
R307, 308	ERD25TJ103	Carbon, 10kΩ, 1/4W, ± 5%
R309	ERD25TJ102	Carbon, 1kΩ, 1/4W, ± 5%
R310	ERD25TJ681	Carbon, 680Ω, 1/4W, ± 5%
R311 ~ 315	ERD25TJ222	Carbon, 2.2kΩ, 1/4W, ± 5%
R316, 317	ERD25TJ333	Carbon, 33kΩ, 1/4W, ± 5%
R318	ERD25TJ563	Carbon, 56kΩ, 1/4W, ± 5%
R319	ERD25TJ222	Carbon, 2.2kΩ, 1/4W, ± 5%
R320	ERD25TJ680	Carbon, 68Ω, 1/4W, ± 5%
R321	ERD25TJ101	Carbon, 100Ω, 1/4W, ± 5%
R322	ERD25TJ680	Carbon, 68Ω, 1/4W, ± 5%
R323, 324	ERD25TJ103	Carbon, 10kΩ, 1/4W, ± 5%
R325, 326	ERD25TJ562	Carbon, 5.6kΩ, 1/4W, ± 5%
R327, 328	ERD25TJ473	Carbon, 47kΩ, 1/4W, ± 5%
R329	ERD25TJ472	Carbon, 4.7kΩ, 1/4W, ± 5%
R330	ERD25TJ102	Carbon, 1kΩ, 1/4W, ± 5%
R331	ERD25TJ273	Carbon, 27kΩ, 1/4W, ± 5%
R332	ERD25TJ272	Carbon, 2.7kΩ, 1/4W, ± 5%
R333	ERD25TJ332	Carbon, 3.3kΩ, 1/4W, ± 5%
R334	ERD25TJ102	Carbon, 1kΩ, 1/4W, ± 5%
R336	ERD25TJ222	Carbon, 2.2kΩ, 1/4W, ± 5%
R337	ERD25TJ121	Carbon, 120Ω, 1/4W, ± 5%
R338	ERD25TJ680	Carbon, 68Ω, 1/4W, ± 5%
R339 ~ 341	ERD25TJ152	Carbon, 1.5kΩ, 1/4W, ± 5%
R342	ERD25TJ680	Carbon, 68Ω, 1/4W, ± 5%
R343	ERD25TJ221	Carbon, 220Ω, 1/4W, ± 5%

Ref. No.	Part No.	Part Name & Description
CAPACITORS		
C1 [M]	ECQM4473KZ	Polyester, 0.047μF, 400V, ±10%
C1 [MC]	ECQU1A473MC	Polyester, 0.047μF, 400V, ±10%
C2, 3	ECQU1A102MD	Polyester, 0.001μF, 125V, ±20%
C4	ECEB250V100U	Electrolytic, 100μF, 250V
C5, 6	ECEA2AS200	Electrolytic, 22μF, 100V
C7	ECQM1H223KZ	Polyester, 0.022μF, 50V, ±10%
C8	ECQM4473KZ	Polyester, 0.047μF, 400V, ±10%
C9	ECEA2AS101	Electrolytic, 100μF, 100V
C10	ECEA1HS101	Electrolytic, 100μF, 16V
C11	ECQU1A102MD	Polyester, 0.001μF, 125V, ±20%
C12	ECKD3A101MB2	Ceramic, 100pF, 10V
C21	ECEA1VS330	Electrolytic, 33μF, 35V
C101	ECQM1H104KZ	Polyester, 0.1μF, 50V, ±10%
C102 ~ 107	ECQM1H123KZ	Polyester, 0.012μF, 50V, ±10%
C108 ~ 110	ECEA1VS330	Electrolytic, 33μF, 35V
C111	ECSF25E1ZEN	Tantalum, 1μF, 25V
C112	ECSF25E2R2Z	Tantalum, 2.2μF, 25V
C113	ECS25E1ZEN	Tantalum, 1μF, 25V
C114	ECEA25Z100	Electrolytic, 100μF, 25V
C115	ECQM1H104KZ	Polyester, 0.1μF, 50V, ±10%
C116	ECQM1H562KZ	Polyester, 0.0056μF, 50V, ±10%
C117	ECQM1H223KZ	Polyester, 0.022μF, 50V, ±10%
C118	ECQM1H154KZ	Polyester, 0.15μF, 50V, ±10%
C119	ECEA1HS100	Electrolytic, 10μF, 50V
C120	ECQM1H823KZ	Polyester, 0.082μF, 50V, ±10%
C121	ECEA1ES470	Electrolytic, 47μF, 25V
C201	ECSF35E8R33	Tantalum, 0.33μF, 35V
C202	ECQM1H562KZ	Polyester, 0.0056μF, 50V, ±10%
C203	ECQM1H103KZ	Polyester, 0.01μF, 50V, ±10%
C204	ECQM1H104KZ	Polyester, 0.1μF, 50V, ±10%
C205	ECQM1H683JZ	Polyester, 0.068μF, 50V, ± 5%
C206	ECQM1H562KZ	Polyester, 0.0056μF, 50V, ±10%
C208 ~ 210	ECQM1H104KZ	Polyester, 0.1μF, 50V, ±10%
C211	ECQM1H562KZ	Polyester, 0.0056μF, 50V, ±10%
C212	ECKD1E104ZFZ	Ceramic, 0.1μF, 25V
C213	ECEA1ES470	Electrolytic, 47μF, 25V
C214	ECEA1HS100	Electrolytic, 10μF, 50V
C215	ECKD1E104ZFZ	Ceramic, 0.1μF, 25V
C216	ECQM1H562KZ	Polyester, 0.0056μF, 50V, ±10%
C217, 218	ECEA1ES470	Electrolytic, 47μF, 25V
C219 ~ 221	ECQM1H104KZ	Polyester, 0.1μF, 50V, ±10%
C301	ECKD1H102MD	Ceramic, 0.001μF, 50V, ±20%
C302	ECSF25E1ZEN	Tantalum, 1μF, 25V
C303, 304	ECEA1HS100	Electrolytic, 100μF, 50V
C305, 306	ECSF25E1ZEN	Tantalum, 1μF, 25V
C307	ECQM1H822KZ	Polyester, 0.0082μF, 50V, ±10%
C308	ECKD1E104ZFZ	Ceramic, 0.1μF, 25V
C309	ECCD1H330K	Ceramic, 33pF, 50V
C310	ECCD1H331K	Ceramic, 330pF, 50V
C311	ECCD1H221K	Ceramic, 220pF, 50V
C312	ECEA1HS100	Electrolytic, 10μF, 50V
C313	ECQM1H102KZ	Polyester, 0.001μF, 50V, ±10%
C314	ECQM1H103KZ	Polyester, 0.01μF, 50V, ±10%
C315	ECQM1H104KZ	Polyester, 0.1μF, 50V, ±10%
C316	ECQM1H102KZ	Polyester, 0.001μF, 50V, ±10%
C317	ECKD1E104ZFZ	Ceramic, 0.1μF, 25V
C318	ECEB1AS221	Electrolytic, 220μF, 10V
C319, 320	ECEA1AS221	Electrolytic, 220μF, 10V

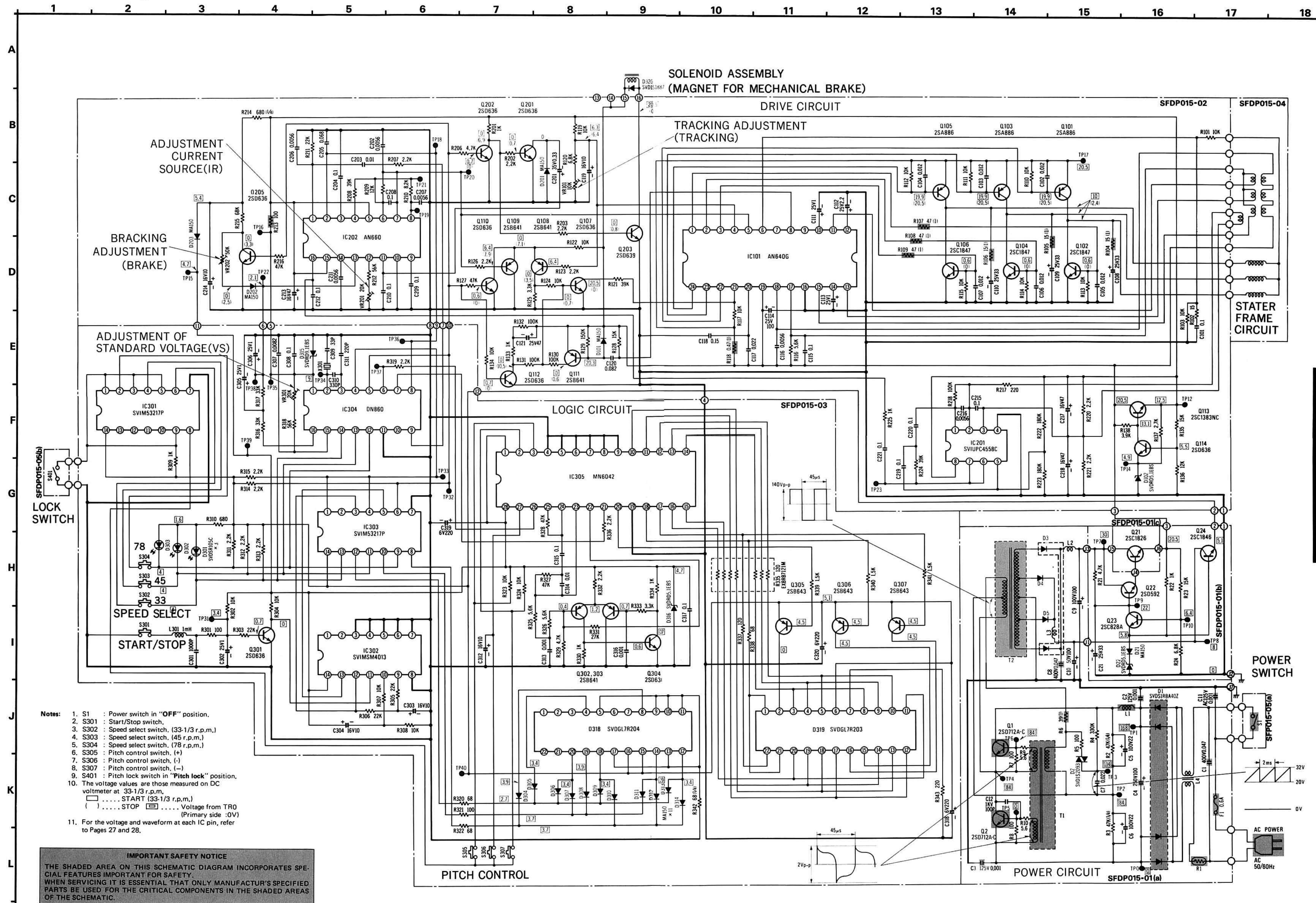

- Notes:**
- S1 : Power switch in "OFF" position.
 - S301 : Start/Stop switch.
 - S302 : Speed select switch. (33-1/3 r.p.m.)
 - S303 : Speed select switch. (45 r.p.m.)
 - S304 : Speed select switch. (78 r.p.m.)
 - S305 : Pitch control switch. (+)
 - S306 : Pitch control switch. (-)
 - S307 : Pitch control switch. (-)
 - S401 : Pitch lock switch in "Pitch lock" position.
 - The voltage values are those measured on DC voltmeter at 33-1/3 r.p.m.
 () START (33-1/3 r.p.m.)
 () STOP (Primary side :0V)
 - For the voltage and waveform at each IC pin, refer to Pages 27 and 28.

IMPORTANT SAFETY NOTICE
 THE SHADED AREA ON THIS SCHEMATIC DIAGRAM INCORPORATES SPECIAL FEATURES IMPORTANT FOR SAFETY. WHEN SERVICING IT IS ESSENTIAL THAT ONLY MANUFACTURER'S SPECIFIED PARTS BE USED FOR THE CRITICAL COMPONENTS IN THE SHADED AREAS OF THE SCHEMATIC.

SP-15

SP-15

■ REFERENCE VOLTAGE AND WAVEFORM AT EACH IC PIN

IC101 (AN640G)

	Start	Stop		Start	Stop		Start	Stop
①		0 V	⑩		15 V	⑲	20.5V	20.5V
②			⑫			⑳	15.4V	1.4V
③			⑭			㉑	20.6V	16.4V
④	6.3V	6.4V	⑪		Same as at left	⑳	19.9V	20.5V
⑤	6.3V	7.9V	⑬					
⑥	4.8V	2.2V	⑮					
⑦	5 V	5 V	⑯	0V	0 V			
⑧	20.5V	20.5V	⑰	15.5V	15.5V			
⑨		0.2V	⑱		Same as at left			

IC201 (SVIUPC4558C)

	Start	Stop		Start	Stop
①		9V	②	9 V	9 V
⑤			③	0 V	0 V
⑥			④	17.6V	17.6V
⑦			⑧		

IC202 (AN660)

	Start	Stop		Start	Stop		Start	Stop
①		0 V	⑤	12.6V	Same as at left	⑫	2.4V	2.1V
			⑥	6.3V		⑬	2.2V	2.1V
			⑦	6.5V		⑧ V		
②		0 V	⑧	6.3V	5.1V	⑭		7.5V
③				5.8V	⑨			7.5V
④	5.8V	6 V			⑩		0 V	
			⑪		7.5V			

IC301 (SVIM53217P)

	Start	Stop
①	0.2V	0.2V
②	0 V	0 V
③	0.2V	0.2V
④	0 V	0 V
⑤	0.2V	0.2V
⑥		
⑦	0 V	0 V
⑧		
⑨	0.2V	0.2V
⑭	5.1V	5.1V

IC302 (SVIMSM4013)



	Start	Stop
③		
④		
⑤		
⑥	0 V	0 V
⑦		
⑧		
⑨	0 V	4.7V
⑩	0 V	0 V
⑪		
⑫	0 V	4.7V
⑬	4.7V	0 V
⑭	4.7V	4.7V

IC303 (SVIM53217P)

	Start	Stop
①	0.1V	4.2V
③	0 V	4.7V
④	0.1V	4.2V
⑤	4.7V	0 V
⑥	3.2V	0 V
⑦	0 V	0 V
⑧	3.8V	3.8V
⑨	4 V	4 V
⑩	3.8V	3.8V
⑪	4 V	4 V
⑫	0.4V	0.4V
⑬	0 V	0 V
⑭	5.1V	5.1V

■ REFERENCE VOLTAGE AND WAVEFORM AT EACH IC PIN

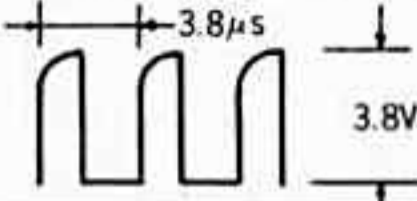
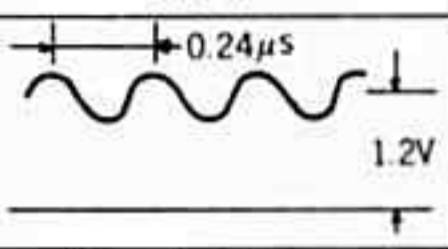
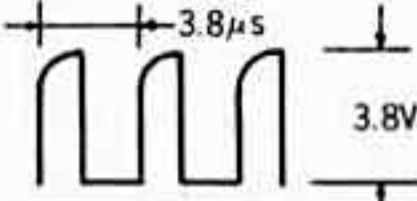
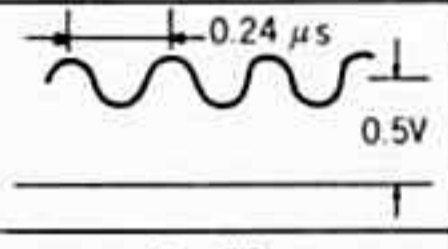
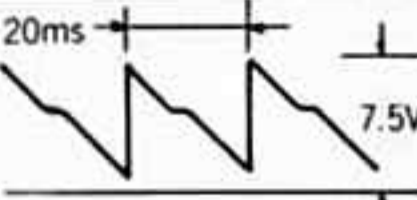
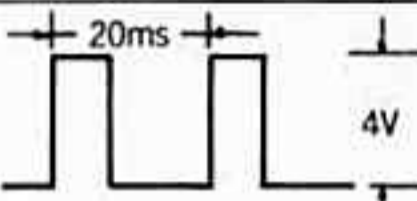
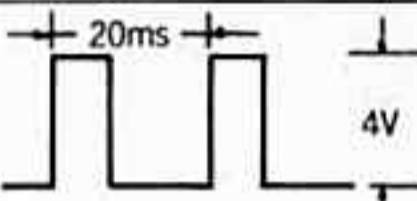
IC304 (DN860)

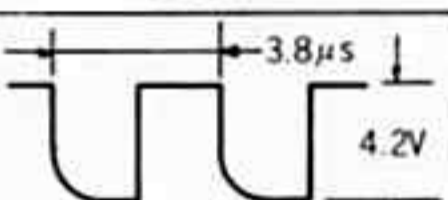
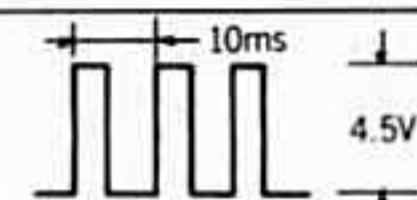
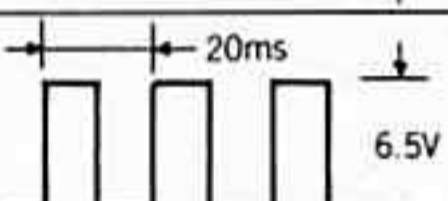
	Start	Stop		Start	Stop		Start	Stop
①	9.3V	9.3V			Same as at left	⑪	0V	0V
②		Same as at left	⑦		Same as at left	⑫	4V	4V
③		Same as at left	⑧		0V	⑬	4V	4V
④	0 V	3.2V			4V	⑭	0V	0V
⑤	3.2V	0 V	⑨		4V	⑮		Same as at left
⑥		Same as at left	⑩		Same as at left	⑯		0V

IC305 (MN6042)

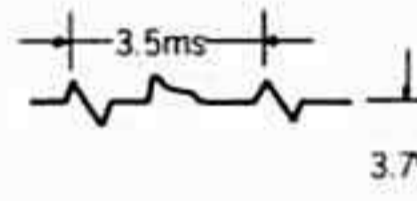
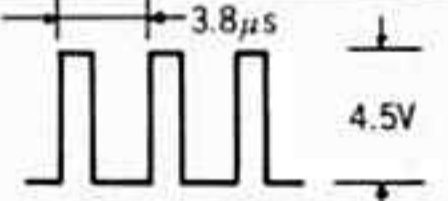
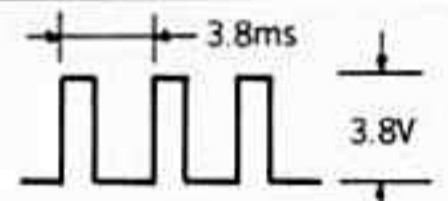
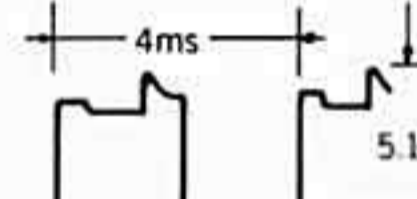
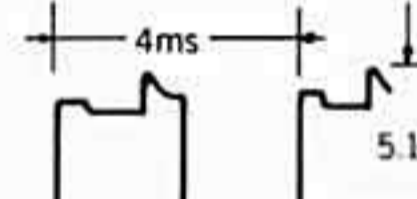
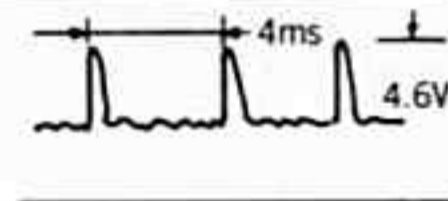
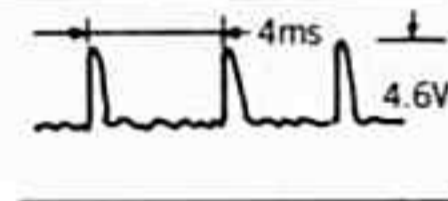
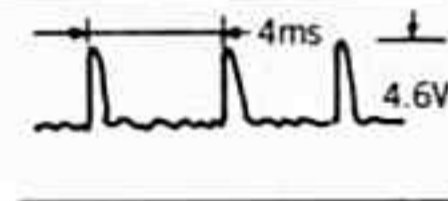
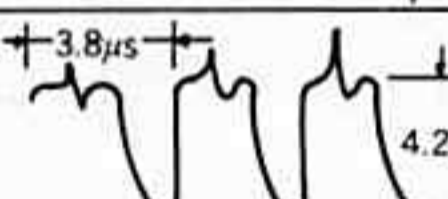
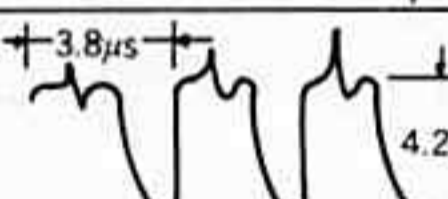
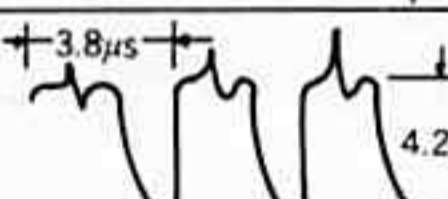
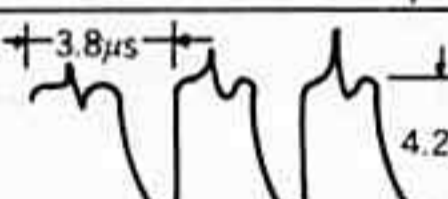
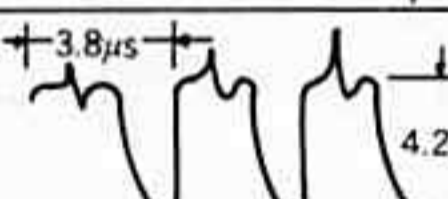
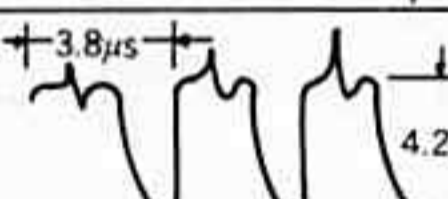
	Start	Stop		Start	Stop		Start	Stop		
①	4.6V	4.6V			Same as at left	⑲		Same as at left		
②			⑳			Same as at left				
③			⑰				㉑		1.8V	1.8V
④			⑱				㉒		2.2V	2.2V
⑤			㉓				Same as at left			
⑥	㉔		Same as at left							
⑦	㉕			Same as at left						
⑩	㉖				Same as at left					
⑪	㉗					Same as at left				
⑫	㉘						Same as at left			
⑬	㉙		Same as at left							
⑭	㉚			Same as at left						
⑮	㉛				Same as at left					

— NOTE —

EXPLODED VIEWS

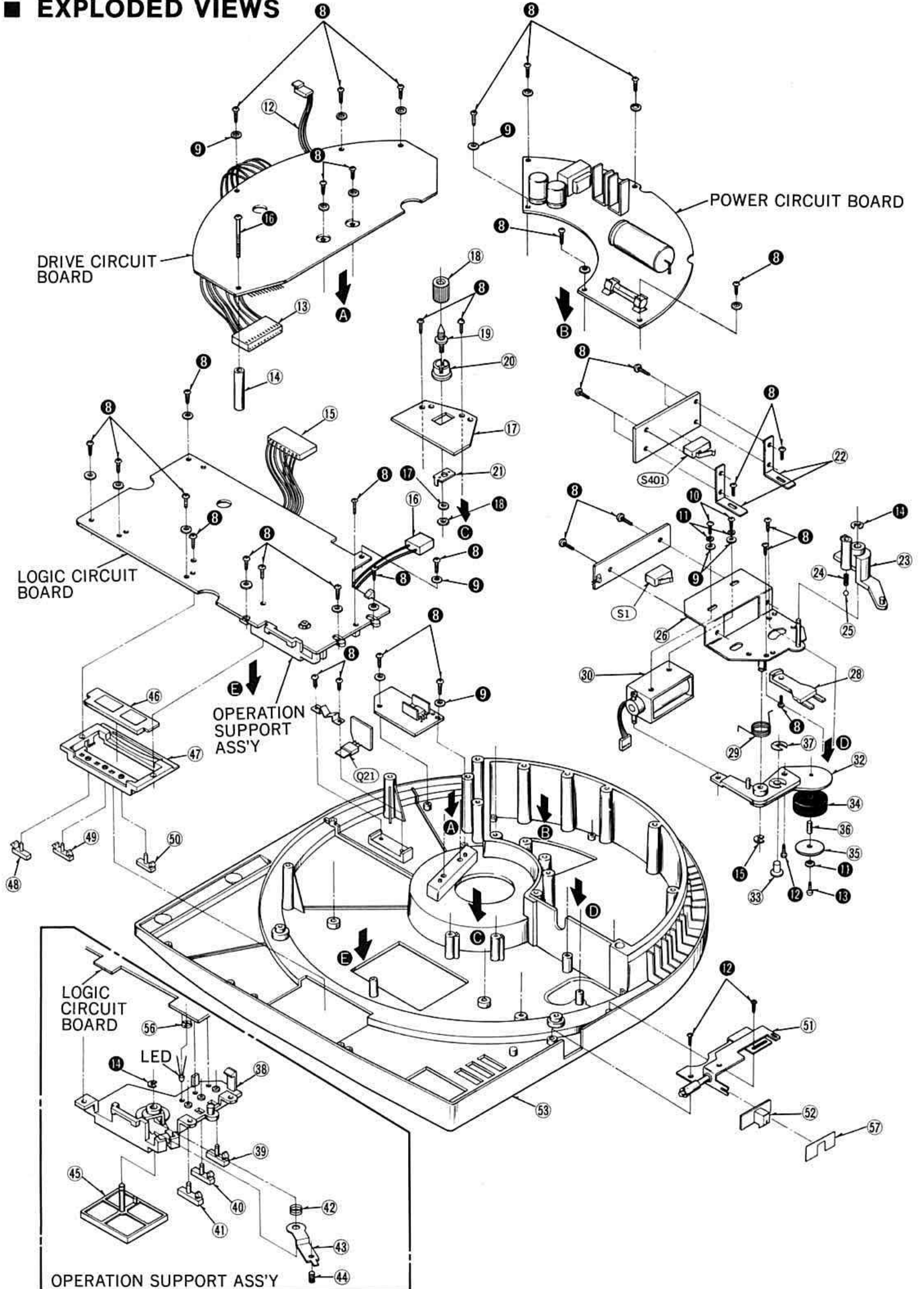

EXPLODED VIEWS

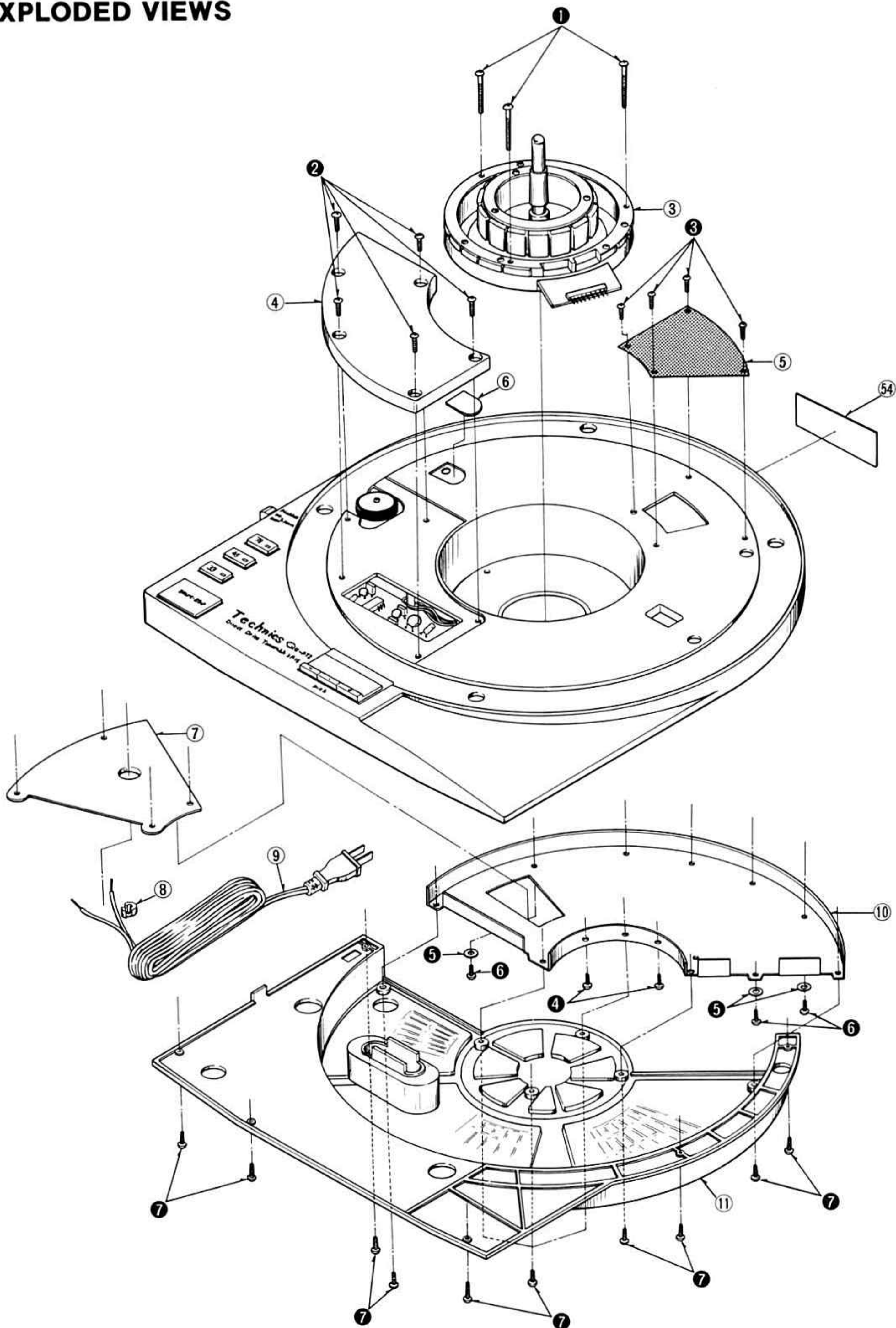

REPLACEMENT PARTS LIST

Important Safety Notice

Components identified by shaded area have special characteristics important for safety. When replacing any of these components use only manufacturer's specified parts.

- Notes:** 1. Part numbers are indicated on most mechanical parts. Please use this part number for parts orders.
2. SP-15 (M) → [M], SP-15 (MC) → [MC].

Ref. No.	Part No.	Part Name & Description
CABINET and CHASSIS PARTS		
1	SFTG015-01	Turntable Mat
2	SFTE015-01A	Turntable
3	SFMZ015-02Z	Stator Frame Ass'y
4	SFUM015-07	Cover, Turntable
5	SFUP015-09	Plate, Shield, Turntable
6	SFUP015-13	Cap, Turntable
7	SFUP015-11	Plate, AC Cord
8	SFHK040L	Bushing, AC Cord
9	QFC1201MA	AC Cord
10	SFUP015-12	Plate, Shield, Power Circuit
11	SFUM015-09	Cover, Bottom
12	SFDJ015-02E	Connector, Power Circuit
13	SFDJ134-01E	Connector, Stator Frame Ass'y
14	SFXO015-01	Pipe, Logic Circuit Screw
15	SFDJ015-03E	Connector, Drive
16	SFDJ015-01E	Connector, Pitch Lock Switch
17	SFUP015-04	Plate, Ground Wire
18	SNE273-1	Knob, Ground Terminal
19	SNE271S	Screw, Ground Terminal
20	SGE401	Ornament, Ground Terminal
21	SJT719	Spacer, Ground Terminal
22	SFUP015-10	Bracket, Power Circuit
23	SFUM015-03	Cam, Power Switch
24	SFQA015-02	Spring, Power Switch Cam
25	SFYB-M30	Ball, Power Switch Cam
26	SFUP015-03E	Bracket, Power Switch
28	SFUM015-04	Cam, Pitch Lock Switch
29	SFQS015-01	Spring, Brake
30	SFDZ015-01E	Solenoid Ass'y
32	SFUM015-06E	Brake Ass'y
33	SFXJ015-06	Shaft, Eccentricity
34	SFUZ015-01	Roller, Brake
35	SFUP015-14	Spacer, Roller
36	SFXO015-02	Pipe, Roller
37	SFXW130-01	Circlip, Roller
38	SFUM015-01	Plate, Operation
39	SFKT015-03E	Knob, Speed Select (78 rpm)
40	SFKT015-02E	Knob, Speed, Select (45 rpm)
41	SFKT015-01E	Knob, Speed Select (33 rpm)
42	SFQA015-01	Spring, Supporter
43	SFUP015-07	Supporter, Switch
44	SFRTN30060	Screw, Supporter
45	SFKT015-06	Knob, Start/Stop
46	SFUM015-05E	Supporter, Logic Circuit
47	SFUM015-62	Plate, Operation
48	SFKT015-08	Knob, Operation (C)
49	SFKT015-04	Knob, Operation (A)
50	SFKT015-05	Knob, Operation (B)
51	SFUP015-08Z	Plate, Slider
52	SFKT015-07	Knob, Power Switch
53	SFAC015-01	Cabinet, Panel
54 [M]	SFNN015M01	Name Plate
54 [MC]	SFNN015C01	Name Plate
56	SFUM015-11	Spacer, LED

Ref. No.	Part No.	Part Name & Description
57	SFUP015-15	Cover, Power Switch
SCREWS and CIRCLIPS		
①	XTN3+30B	Screw
②	XTN3+8BFZ	Screw
③	XTN3+6BFZ	Screw
④	XTN3+10B	Screw
⑤	XWG3FZ	Washer
⑥	XTN3+10BFZ	Washer
⑦	XTS3+10BFZ	Washer
⑧	XTN3+8B	Washer
⑨	XWG3	Washer
⑩	XSN3+6S	Screw
⑪	XWA3B	Washer
⑫	XTN3+6B	Screw
⑬	XSN3+12S	Screw
⑭	XUC3FT	Circlip
⑮	XUC4FT	Circlip
⑯	XTN3+40B	Screw
⑰	XWA4B	Washer
⑱	XNG4ES	Nut
ACCESSORIES		
A1 [M]	SFNU015M01	Instruction Book
A1 [MC]	SFNU015C01	Instruction Book
A2	SFWE212-01	Adaptor, 45 r.p.m
A3	SFEL028-01E	Ground Wire
A4	XMM41+32FU	Screw
A5	SFXW028-01	Washer
A6 [M]	SFNU015M02	Instruction, Dimension Drawing
A6 [MC]	SFNU015C02	Instruction, Dimension Drawing
A7	SFYF07A10	Polyethylene Bag
PACKING PARTS		
P1 [M]	SFHP015M01	Carton
P1 [MC]	SFHP015C01	Carton
P2	SFHH015-01	Pad (Left)
P3	SFHH015-02	Pad (Right)
P4	SFHH015-03	Pad
P5	SFHD015-01	Pad, Top
P6	SFYF60A60	Polyethylene Bag, Unit
P7	SFYH40X45	Polyethylene Bag, Turntable
P8	SFYF10A30	Polyethylene Bag, Cord

■ PARTS IDENTIFICATION

