

# Service Manual

Stereo Tuner

Tuner

## ST-CA1060

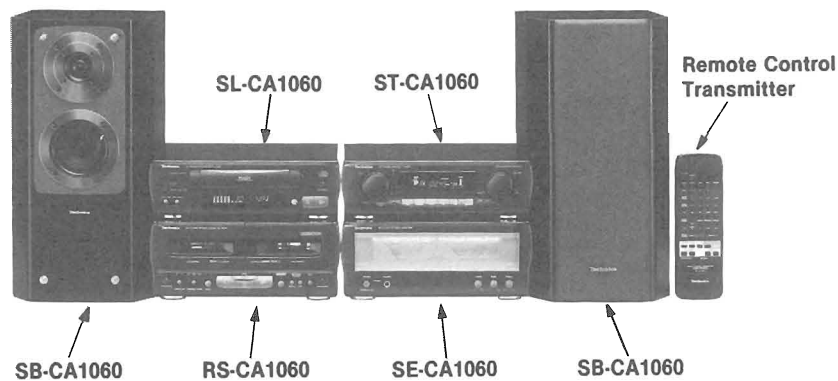

Colour

(K) ... Black Type

Areas

Suffix for Model No.	Area	Colour
(E)	Europe.	(K)
(EG)	Germany and Italy.	

System: SC-CA1060

Because of unique interconnecting cables, when a component requires service, send or bring in the entire system.

## SPECIFICATIONS

### Pre-amplifier section

Input sensitivity/impedance

PHONO 2.5 mV/47 k $\Omega$   
DCC, (VDP, VCR1, VCR2) 250 mV/15 k $\Omega$

Output level

VCR1/DCC RECOUNT 150 mV/1.5 k $\Omega$ 

Frequency response

PHONO 30 Hz – 15 kHz/+1.5 to –2.0 dB  
DCC, (VCD, VCR1, VCR2) 20 Hz – 40 kHz

### FM tuner section

Frequency range

87.50 – 108.00 MHz  
(0.05 MHz steps)

Sensitivity

1.8  $\mu$ V (IHF usable)  
1.5  $\mu$ V

S/N

MONO 70 dB (75 dB, IHF)

Stereo separation 1 kHz

35 dB

Antenna terminal(s)

75  $\Omega$  (unbalance)

### AM tuner section

Frequency range

MW 522 – 1611 kHz (9 kHz steps)  
530 – 1620 kHz (10 kHz steps)

LW 144 – 288 kHz (9 kHz steps)

Sensitivity (S/N 20 dB)

MW

500  $\mu$ V/m

LW

50  $\mu$ V

### Timer section

Clock

Quartz-lock type

Function

24-hour programmable;

Play timer (1 time), Rec timer (1 time),

Sleep (120 min., 1 min. intervals)

Setting

1 minute – 23 hours 59 minutes

(1 min. intervals)

### General

Dimensions (W  $\times$  H  $\times$  D)280  $\times$  89  $\times$  287 mm

Weight

1.75 kg

### Notes:

- Weight and dimensions shown are approximate.
- Design and specifications are subject to change without notice.

System	Stereo Tuner	Compact disc player	Stereo Amplifier	Cassette deck	Speaker
SC-CA1060	ST-CA1060	SL-CA1060	SE-CA1060	RS-CA1060	*SB-CA1060

\* Made in PAES

# Technics®

# CONTENTS

	<b>Page</b>
INSTALLATION .....	2
LOCATION OF CONTROLS .....	3
SETTING THE TIME .....	3
CONNECTIONS .....	4, 5
CONCERNING THE REMOTE CONTROL .....	5, 6
QUICK REFERENCE OF REMOTE CONTROL OPERATION .....	6, 7
OPERATION CHECKS AND MAIN COMPONENTS REPLACEMENT PROCEDURES .....	8, 9
POWER SUPPLY WITH TUNER ST-CA1060 .....	9
REPLACEMENT OF THE FOOT .....	10

	<b>Page</b>
TERMINAL FUNCTION OF IC .....	10
SCHEMATIC DIAGRAM .....	11~20
BLOCK DIAGRAM .....	21, 22
PRINTED CIRCUIT BOARDS .....	23~26
TERMINAL GUIDE OF IC'S, TRANSISTORS AND DIODES .....	27
WIRING CONNECTION DIAGRAM .....	27
REPLACEMENT PARTS LIST .....	28, 29, 33
RESISTORS AND CAPACITORS .....	30, 31
CABINET PARTS LOCATION .....	32

**Note:** Refer to the replacement Accessories and Packaging of Service manual for Model No. SE-CA1060 (E, EB, EG), Order No. AD9406171C8.

# INSTALLATION

## Stacking the components

Install the various components as shown in the illustration.

System	SC-CA1060
Ⓐ Stereo tuner	ST-CA1060
Ⓑ Power amplifier	SE-CA1060
Ⓒ Compact disc player	SL-CA1060
Ⓓ Cassette deck	RS-CA1060
Ⓔ Speakers	SB-CA1060

### Horizontal stacking **A**

### Vertical stacking **B**

### System layout example **C**

To produce a better stereo sound, install both speakers away from the system.

- ① Left speaker
- ② Television set (not included)
- ③ This system
- ④ Right speaker

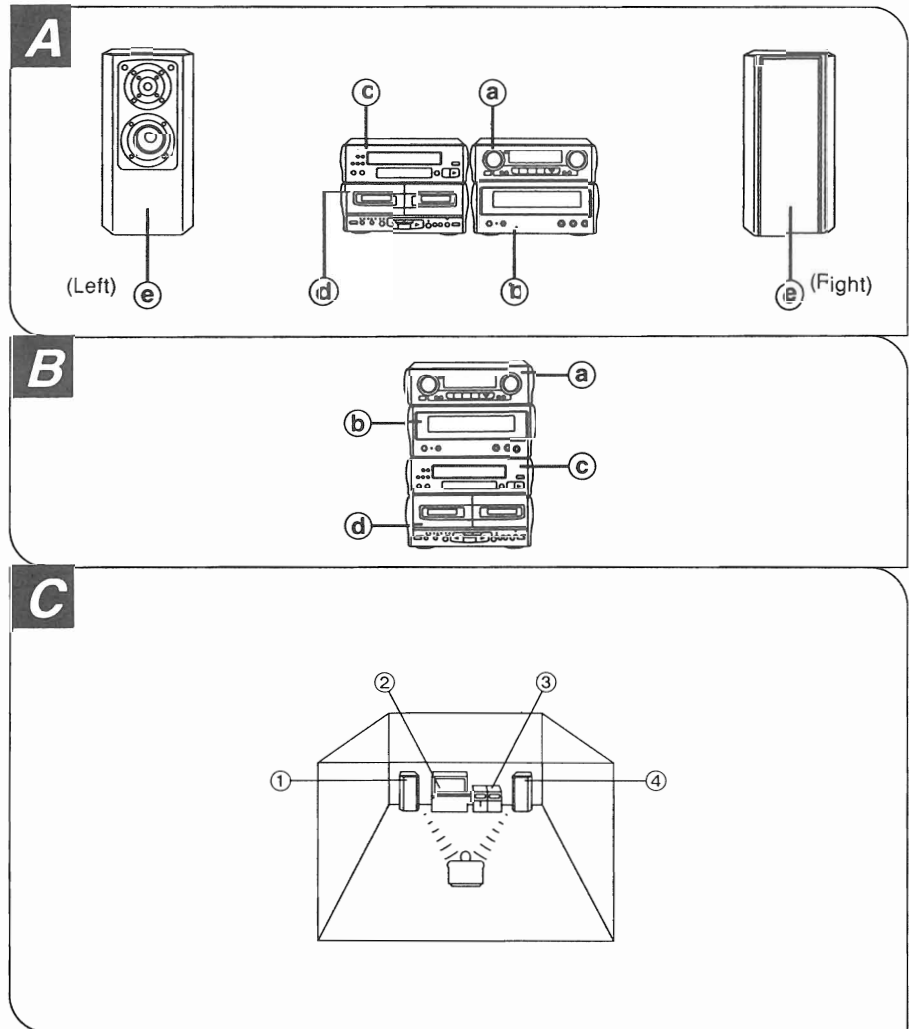

## LOCATION OF CONTROLS

### Stereo tuner section

- ① JOG control
- ② Set button
- ③ External source input select button
- ④ Internal source input select button
- ⑤ Volume control
- ⑥ Remote control signal sensor
- ⑦ Clock/timer button
- ⑧ Tuning mode select button
- ⑨ Record timer button
- ⑩ Play timer button

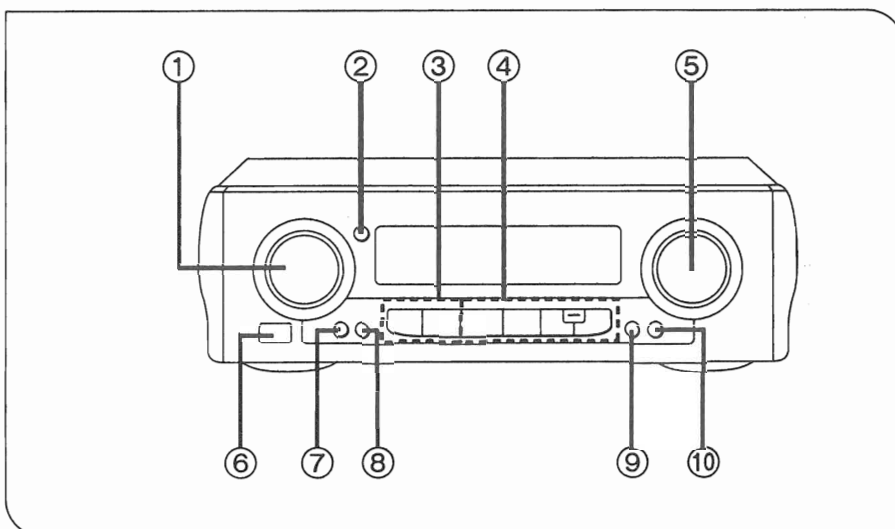

## SETTING THE TIME

This is a 24-hours display clock.

These instructions explain how to set the timer for 16:25 (4:25 p.m.) on Wednesday.

- 1 Switch on the power on the power amplifier.
- 2 ① Press **CLOCK/TIMER** to select "CLOCK".
  - The "CLOCK" display will soon disappear, but you can proceed to the next step within 22 seconds.
- 2 ② Press **SET**.
- 3 ① Turn **JOG** to select the day.
  - ② Press **SET**.
- 4 ① Turn **JOG** to select the hour.
  - ② Press **SET**.
- 5 ① Turn **JOG** to select the minutes.
  - ② Press **SET** to finish setting the time.

The display will return to the previous display after about 2 seconds.

### When "0:00" flashes on the display:

It appears when you connect the power supply cord for the first time or if there has been a power failure. If this happens, reset the time.

### If the minutes setting has gone wrong:

1. Press **CLOCK/TIMER**.
2. Press **SET** 3 times.
3. Turn **JOG** to set the minute, and then press **SET**.

### To display the clock again:

Press **CLOCK/TIMER**.

To return to the previous display, press **CLOCK/TIMER** four times. (or when 22 seconds have passed, the previous display will be returned automatically.)

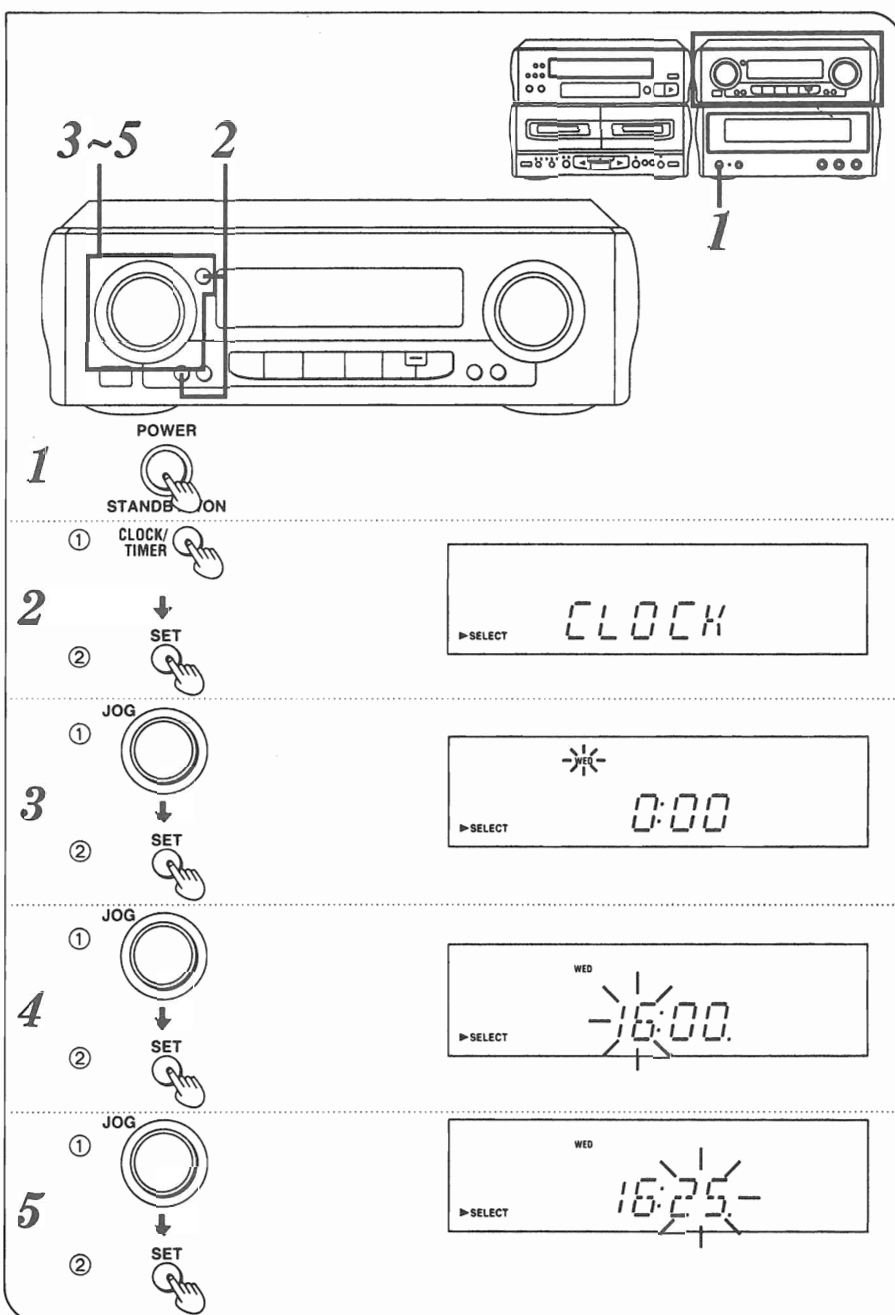

## CONNECTIONS

Connect the AC power supply cord after you have connected all other cables.

### 1 Connect the flat cables.

Hold the connector with the recessed part up and press in at the center until you hear a click.

1. Connect the shorter flat cable to the terminal of the tuner/pre-amplifier and power amplifier.
2. Connect the longer flat cable to the terminal of the tuner/pre-amplifier, compact disc player, and cassette deck.

Route the cable horizontally (underneath the heat outlet grille) so that the side with the white-color lead is positioned at the front.

Be sure to connect the blue-colored connector to B1 (tuner/pre-amplifier). After connection, hold and press the cable as flat to the back of the unit as possible (To minimize noise pickup while listening an AM broadcast).

**Do not try connecting or disconnecting the flat cables while the power is switched to ON.**

### 2 Connect the FM indoor antenna.

Install the antenna on a wall at a height and in a direction which result in the best reception.

The tip of the internal antenna wire should not come into contact with any metal objects.

When you cannot get a good reception with this FM indoor antenna, we recommend you install an FM outdoor antenna (not included).

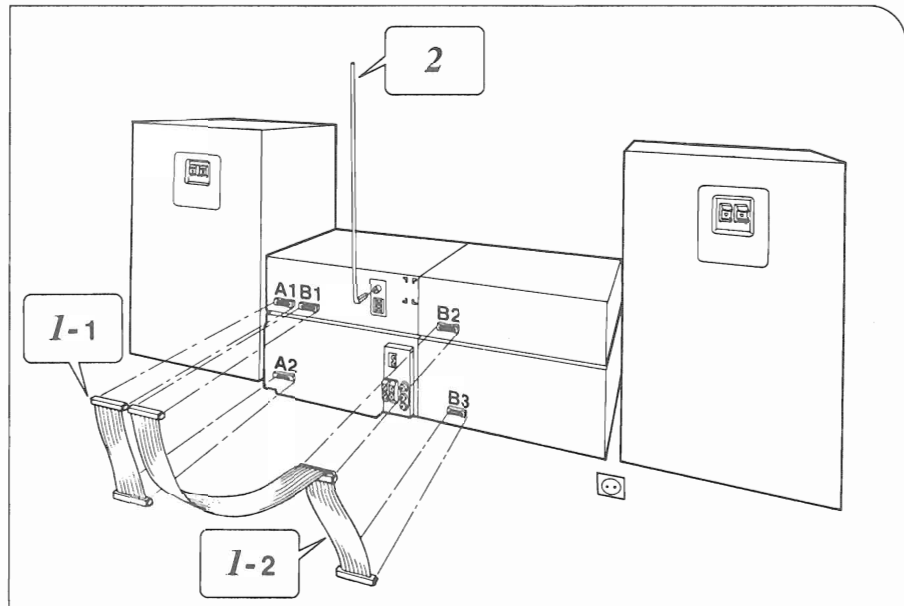

### 1

Connecting

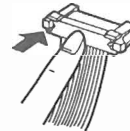

Disconnecting

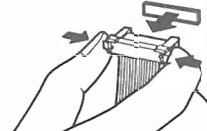

Heat outlet grille

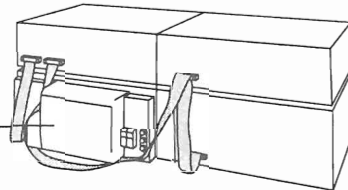

### 2

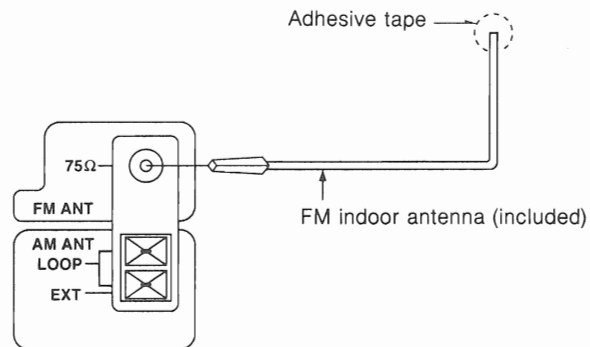

## External unit connection

### DCC (digital compact cassette deck)

**A**

You can make a digital recording on the DCC deck with the optical fiber cable (not included) as shown in the illustration.

### Analog player **B**

**Note**

- Stereo connection cable, video connection cable, optical fiber cable—not included

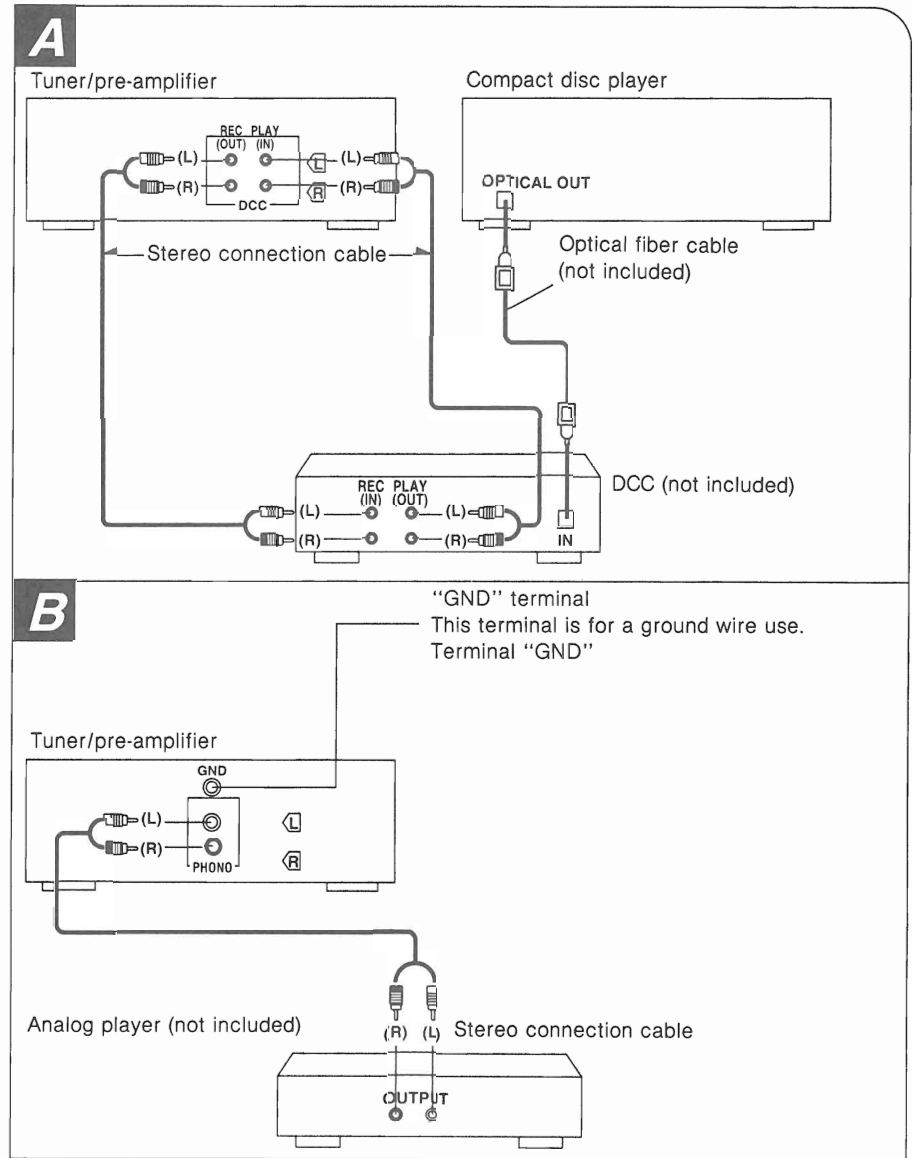

## CONCERNING THE REMOTE CONTROL

### Battery installation **A**

#### Use of batteries

- Do not mix old and new batteries, or batteries of different types (carbon and alkaline, etc.).
- Never subject batteries to excessive heat or flame; do not attempt to disassemble them; and be sure they are not short-circuited.
- If the remote control is not to be used for a long period of time, remove the batteries and store them in a cool, dark place.
- Do not attempt to recharge alkaline or carbon batteries.

#### Battery life

The battery life is about one year.

The batteries should be replaced if commands from the remote control transmitter do not operate the unit even when the transmitter is held close to the front panel.

**A**

Insert the batteries in the correct polarities (⊕, ⊖).

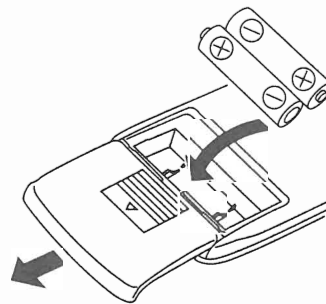

To remove the batteries, pull out the ⊕ side.

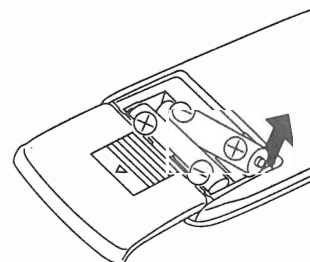

**Correct method of use** B

**Operation notes**

- Aim the remote control's transmission window toward the unit's sensor. Avoid any obstacles.
- Be sure the transmission window and the unit's sensor are free from dust. Excessive dust might affect its performance.
- The operation may not be correct if direct sunlight or other strong light source strikes the receiving sensor of this unit. If there is a problem, place the unit away from the light source.
- If this system is installed in a rack with glass doors, the glass doors' thickness or color might make it necessary to use the remote control a shorter distance from the system.
- Never place heavy items.
- Do not disassemble or reconstruct.
- Do not spill water or other liquids.

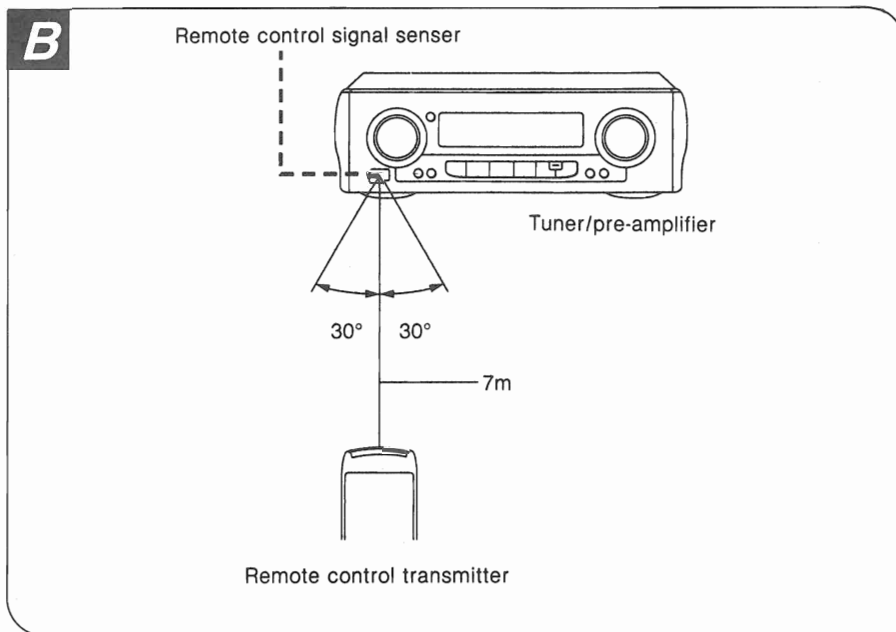

**QUICK REFERENCE OF REMOTE CONTROL OPERATIONS**

<i>Common operation</i>		
	Switching the system on and power standby mode	POWER
	Starting play directly from the power standby condition	TUNERBAND
	Selecting the input source	CD TUNERBAND
	Adjusting the volume	- VOLUME +
	Adjusting the volume balance	L BALANCE R
	Muting the volume temporarily	MUTING -20dB

<i>Tuner/timer operation</i>		
	Listening to radio broadcasts	TUNERBAND
	Switching between FM stereo mode and monaural	AUTOMONO
	Operating/releasing the sleep timer	SLEEP

**Compact disc section**

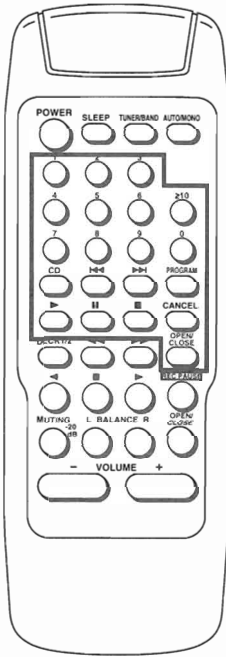

Opening or closing the disc tray	
Starting play	
Temporarily stopping play	
Stopping play	
Skipping tracks	
Starting play from a particular track	
Playing the particular track you programmed	
Cancelling the particular track you programmed	

**Tape section**

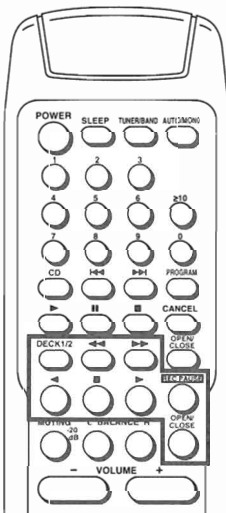

Switching between deck 1 and deck 2	
Opening or closing the cassette holder	
Starting playback	
Finding the beginning of a track	During playback
Fast forwarding or rewinding the tape	In stop mode
Stopping playback	
Recording	

## OPERATION CHECKS AND MAIN COMPONENT REPLACEMENT PROCEDURES

- NOTE**
1. This section describes procedures for checking the operation of the major printed circuit boards and replacing the main components.
  2. For reassembly after operation checks or replacement, reverse the respective procedures. Special reassembly procedures are described only when required.
  3. Illustrated screws are equivalent to actual size.

### 1. Checking for the tuner P.C.B. and operation P.C.B.

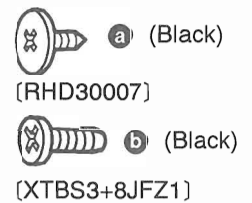
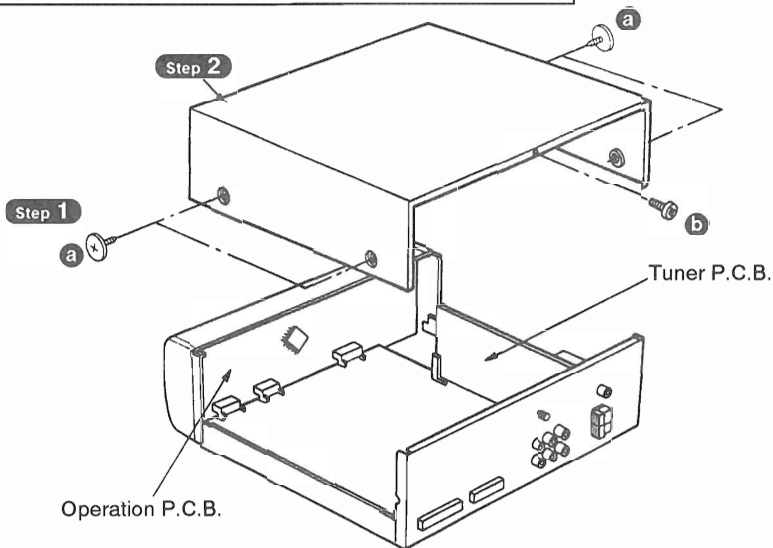

### 2. Checking for the main P.C.B.

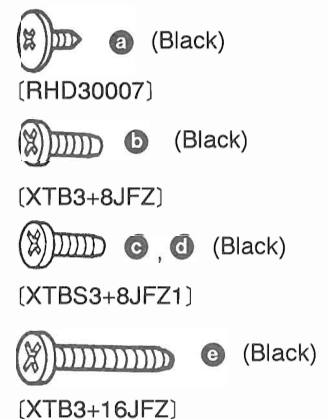
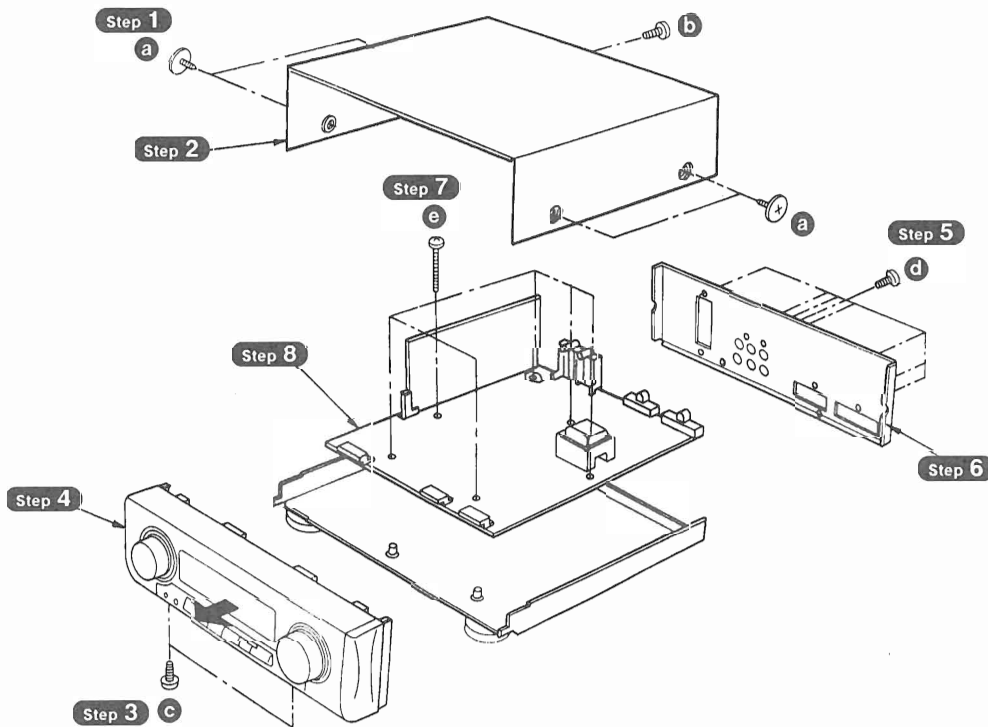



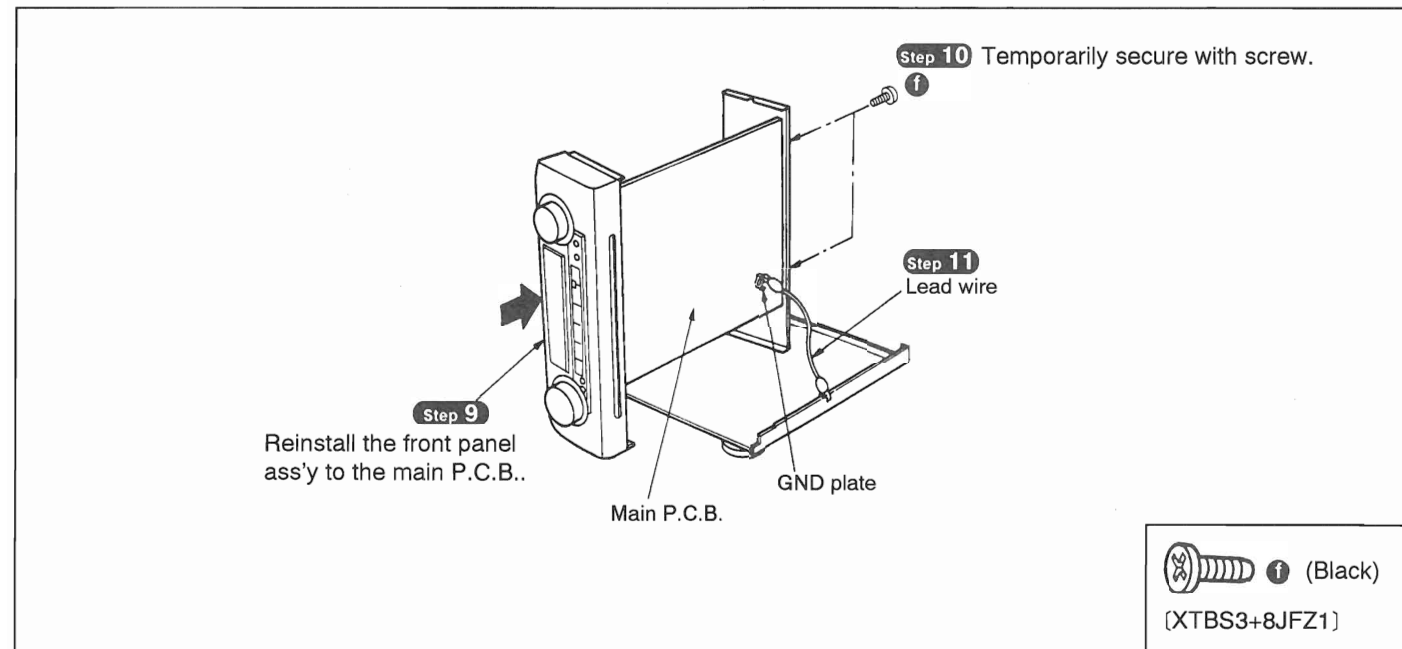

### POWER SUPPLY WITH TUNER ST-CA1060

#### Power Supply to Main PCB

1. Apply 11 V AC power between C724 and C725 using the service tool for AC power supply as shown below.  
(The unit comes to STAND BY Mode.)
2. Short the point P-SW (J391) to the J328 as shown below.  
FL display tube lights and the unit comes to power ON mode.

#### Power Supply to Tuner PCB

1. Apply 15 V DC power to J605 and J2 using the service tool for DC power supply as shown below.

**Note:** When applying DC power, connect between GND CT using the tool.

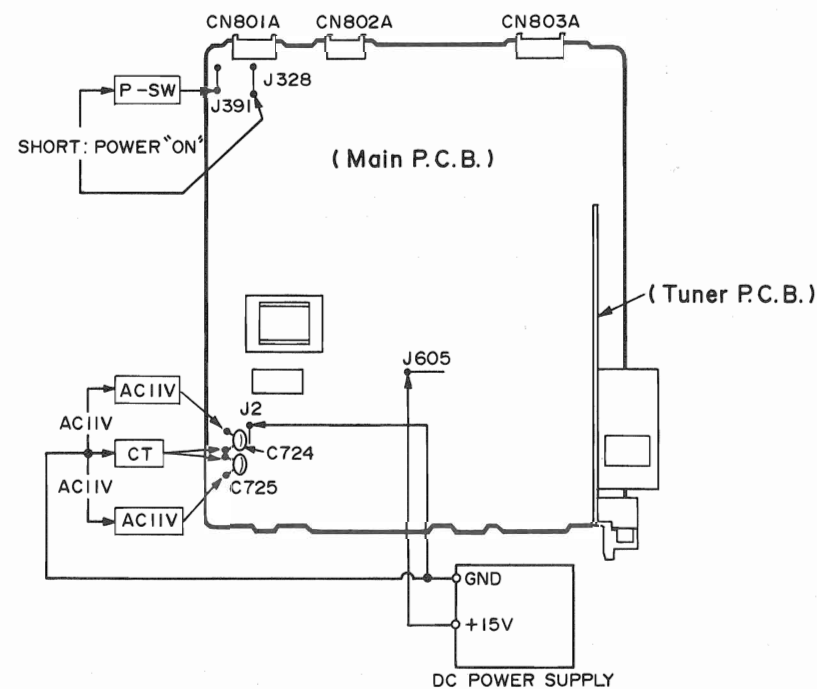

### REPLACEMENT OF THE FOOT

1. Remove the 4 heat melted posts on the Bottom board ass'y with a pair of nippers or similar tool.
2. To replace the foot (RKA0011-3) on the Bottom board ass'y melt the 4 posts with a soldering iron or install it with a screw (XTB3+6J).

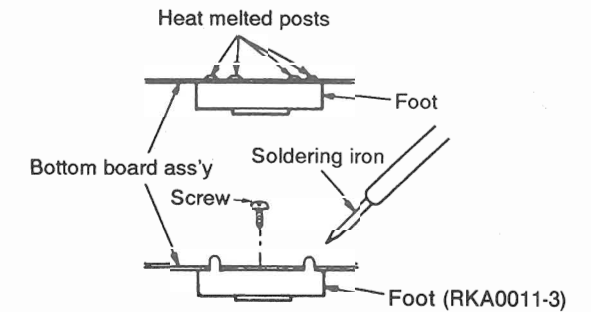

### TERMINAL FUNCTION OF IC

#### IC801 (M38173M6276F): System control/FL drive

Pin No.	Terminal Name	I/O	Function
1	CR TIMER	O	Condensor/resistance oscillation terminal for an electronic failure detection
2	KEY2	I	Operation (MULTI CONTROL) key signal input
3	KEY1	I	Operation key signal input
4	/SD	I	SD signal input for tuner
5	/STEREO	I	STEREO signal input for tuner
6	STB-LATCH	O	Latch signal output
7	CE1	O	Chip enable signal output
8	CLK1	O	Clock signal output
9	DATA	O	Data signal output
10	DATA IN	I	Data signal input
11	A. MUTE	O	Audio muting signal output (Volume of -10dB and less: "H")
12	MUTE	O	Main muting signal output (Normally "L")
13	CLK2	O	Serial clock output
14	CLK3	O	Serial data output
15	B.DATA IN	I	Data input from bus
16	B.CLK IN	I	Clock input from bus
17	B.DATA OUT	O	Data output to bus (Normally "H")
18	B. CLK OUT	O	Clock output to bus (Normally "L")
19	CHECK & SURR	O	POWER ON mode: Output for SUR ON/OFF (During POWER ON: "H") POWER OFF mode: Demultiplier output for clock control
20	POWER & IJO	I/O	Power control output (During POWER ON: "H") Heat detection input (Unusual situation: "H")
21	/TUNER	O	Audio muting 2 signal output (Volume of -70dB and less: "H")
22	TUNER	O	Selector TUNER output (Output in level: "H")
23	VR. JOG B	I	Rotary encoder input for main volume
24	VR. JOG A	I	
25	RC	I	Input for remote control
26	AC IN	I	AC power source input terminal for an electricity failure/clock

Pin No.	Terminal Name	I/O	Function
27	/RESET	I	Reset input terminal
28	10V	I	Power source for pull up (+10V)
29	NC	-	Not connection
30	XIN	I	Connected to a ceramic oscillator for system clock X801 (4.194304 MHz)
31	XOUT	O	
32	V <sub>SS</sub>	-	Connected to GND
33	MIC DET	I	Input for MIC detection (Connection: "L")
34	CS2	I	Input for chip selection
35	CS1		
36	TU. JOG B	I	Rotary encoder input for tuning volume
37	TU. JOG A	I	Rotary encoder input for tuning volume
38	S. MUTE	O	Not used, open
39	C. MUTE	O	Not used, open
40	SURR	O	Not used, open
41 } 50 }	1G } 2G }	O	Grid output for FL display
51 } 67 }	P17 } P1 }	O	Segment signal of FL display
68	CLK4	O	Serial data output
69 } 72 }	V.BASS } CONT4 } CONT3 } CONT1 }	-	Not used, connected to power supply
73	V <sub>DD</sub> BACK-UP	I	+5V impression
74	VP	-	-VP impression for FL display
75	D. GND	-	Connected to GND
76	VREF	-	Standard voltage for A/D converter (Connected to V <sub>CC</sub> )
77	TU. MUTE	O	Muting control terminal
78 } 79 }	CE3 } CE2 }	O	Chip enable terminal
80	NC	-	

# SCHEMATIC DIAGRAM

(Parts list of pages 28~31.)

(This schematic diagram may be modified at any time with the development of new technology.)

### Notes 1:

- S801 : Play timer (PLAY) switch.
- S802 : Record timer (REC) switch.
- S803 : LW/MW (LW/MW) switch.
- S804 : FM (FM) switch.
- S805~807 : Internal source input select switches. [S805: CD, S806: TAPE, S807: PHONO]
- S808 : External source input select (DCC) switch.
- S809 : Tuning mode select (TUNING MODE) switch.
- S810, 811 : Clock/Timer (CLOCK/TIMER) switches. [S810: MODE, S811: SET]

### Signal line

- ▬▬▬▬▬▬ : REC out signal (Lch)
- ▬▬▬▬▬▬ : AM (LW/MW) OSC signal
- ▬▬▬▬▬▬ : AM (LW/MW) signal
- ▬▬▬▬▬▬ : Positive voltage lines
- ▬▬▬▬▬▬ : Negative voltage lines
- ▬▬▬▬▬▬ : FM OSC signal
- ▬▬▬▬▬▬ : FM signal
- ▬▬▬▬▬▬ : AF signal (Lch)
- ▬▬▬▬▬▬ : Surround speaker drive signal
- ▬▬▬▬▬▬ : Center speaker drive signal

### Important safety notice

Components identified by  $\Delta$  mark have special characteristics important for safety. Furthermore, special parts which have purposes of fire-retardant (resistors), high-quality sound (capacitors), low-noise (resistors), etc. are used as occasion calls. When replacing any of components, be sure to use only manufacturer's specified parts shown in the parts list.

• All voltage values shown in circuitry are DC voltage in FM signal (Stereo mono) reception mode.

\* Figures in ( ) Stand for DC-voltage in MW signal reception mode.

\* Figures in < > Stand for DC-voltage in LW signal reception mode.

\* Figures in  $\square$  Stand for DC-voltage in muting mode.

### Caution!

IC and LSI are sensitive to static electricity. Secondary trouble can be prevented by taking care during repair.

- Cover the parts boxes made of plastics with aluminum foil.
- Ground the soldering iron.
- Put a conductive mat on the work table.
- Do not touch the legs of IC or LSI with the fingers directly.

## B OPERATION CIRCUIT

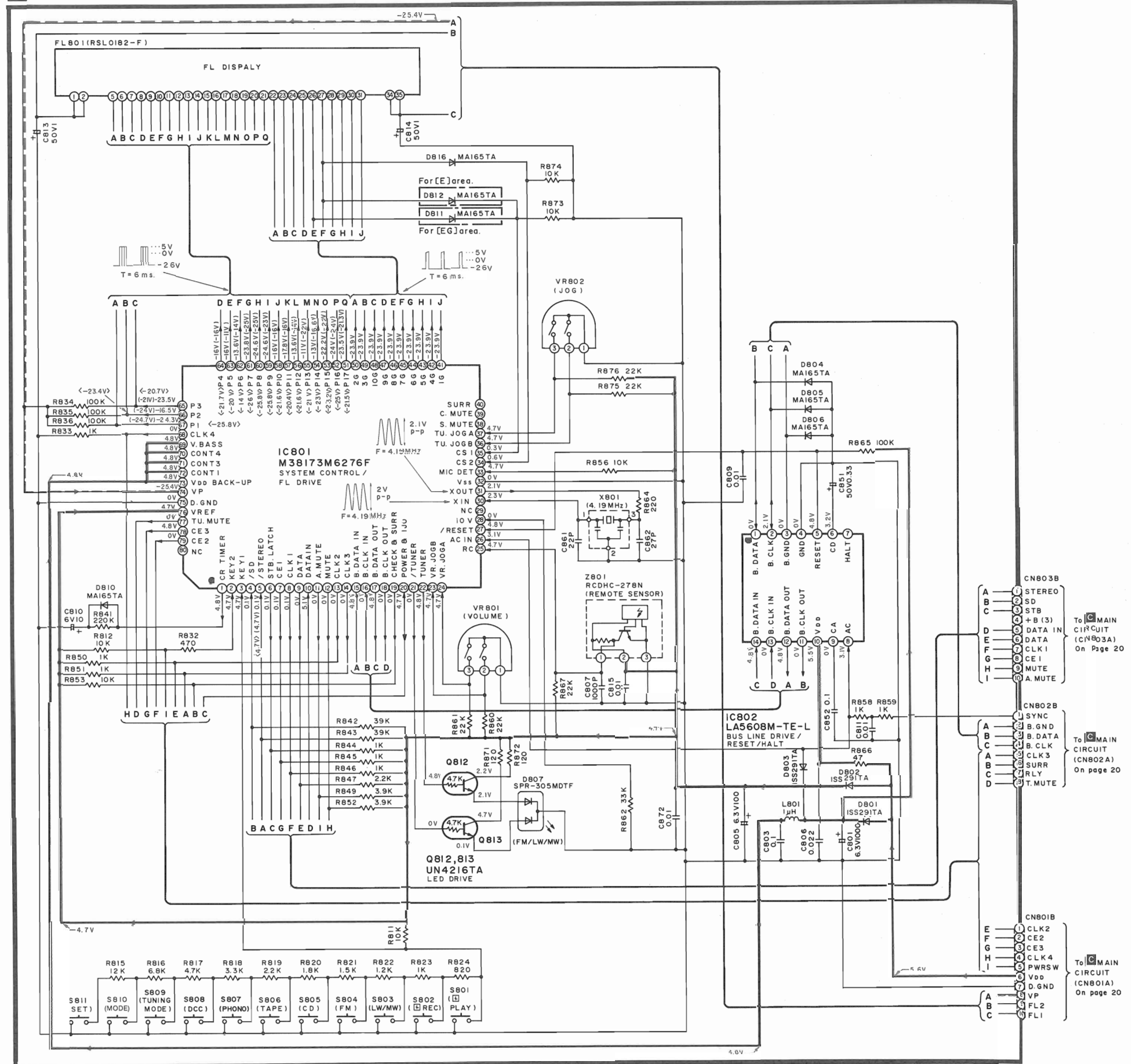

A TUNER CIRCUIT For [E]area.

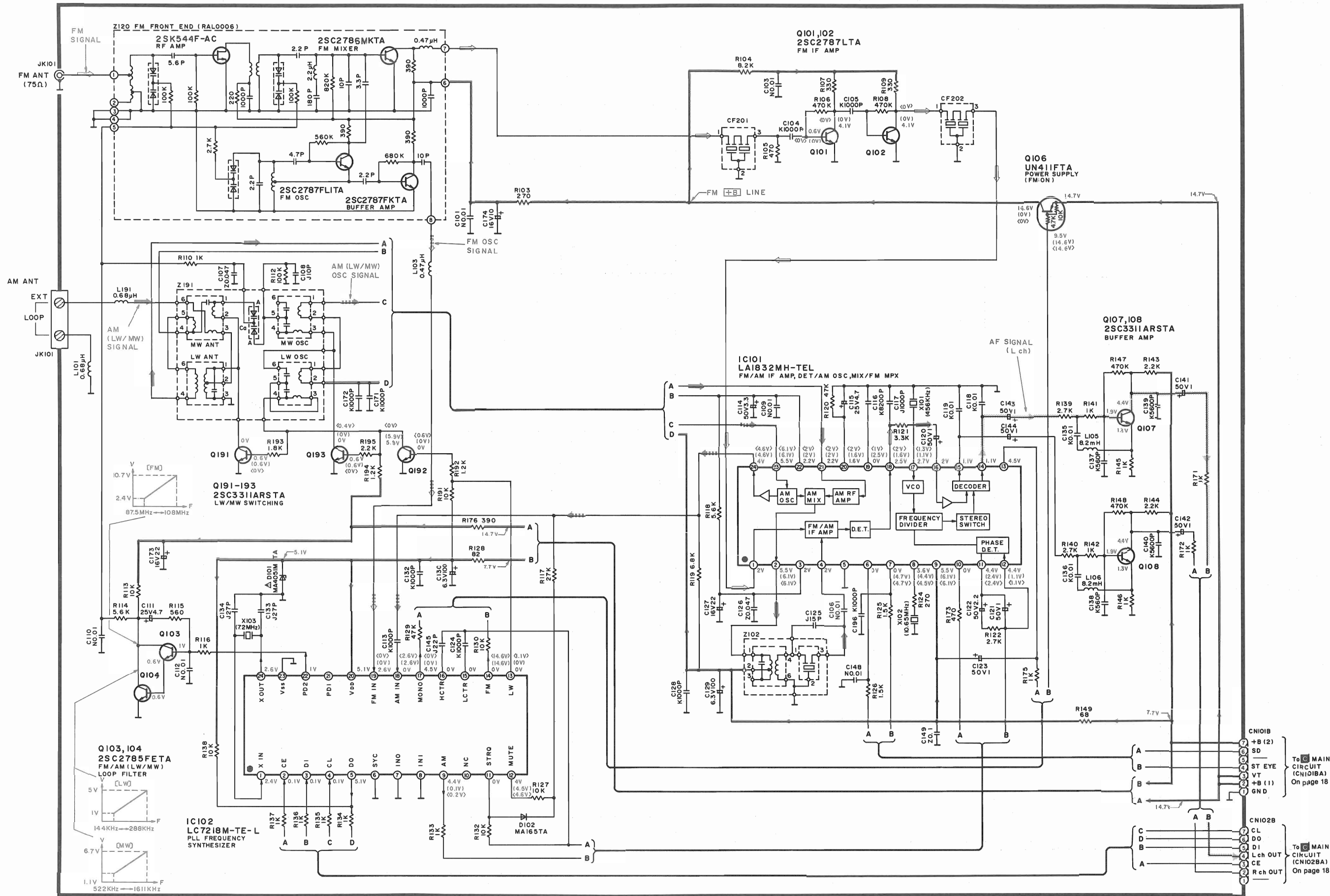

A TUNER CIRCUIT For [EG] area.

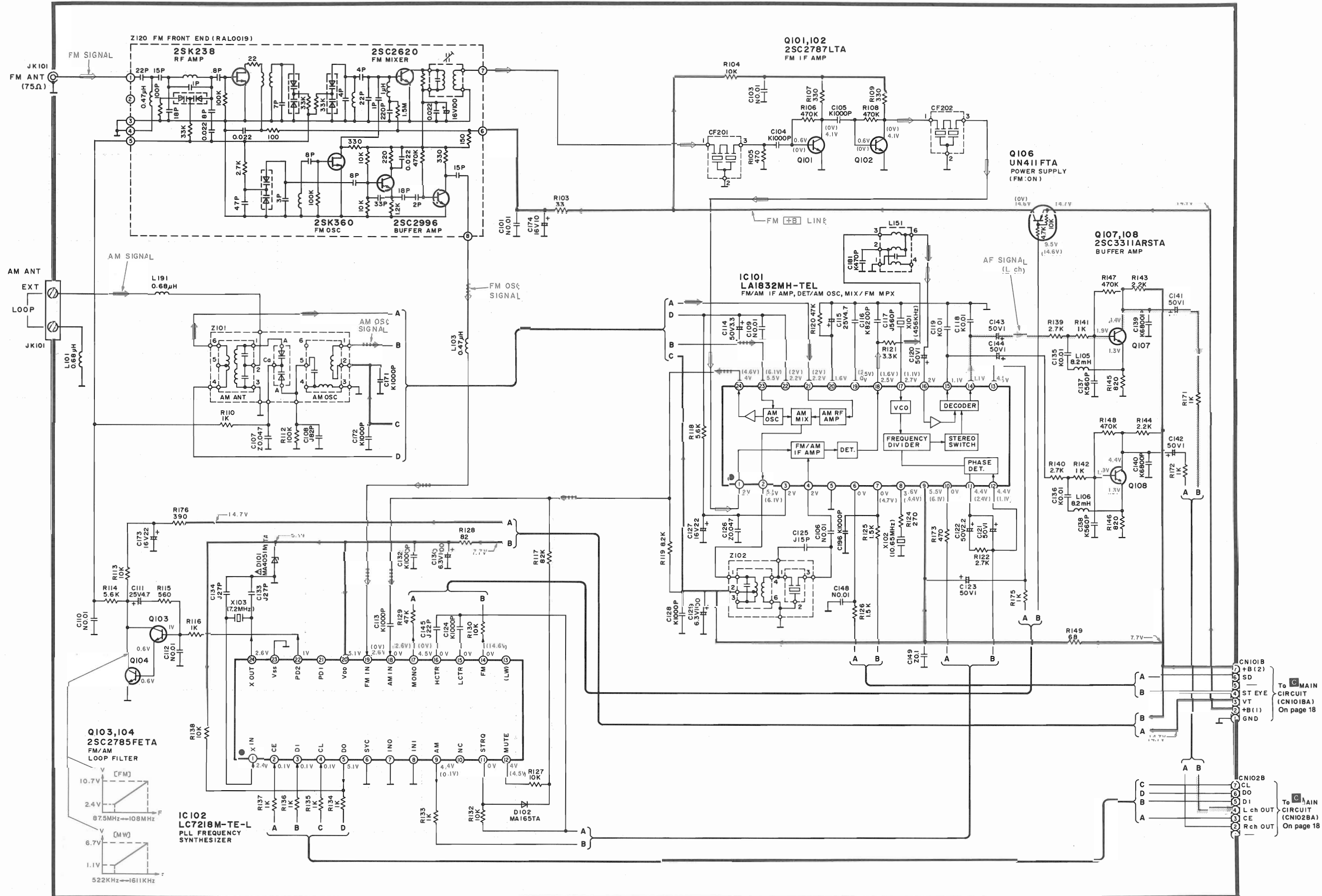

**Q103,104**  
2SC2785FETA  
FM/AM  
LOOP FILTER

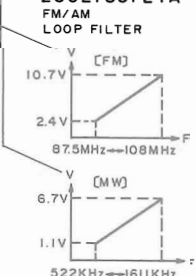

**IC102**  
LC7218M-TE-L  
PLL FREQUENCY  
SYNTHESIZER

CN101B  
+B (2)  
SD  
ST EYE  
VT  
+B (1)  
GND

To MAIN  
CIRCUIT  
(CN101BA)  
On page 18

CN102B  
CL  
DO  
DI  
L ch OUT  
CE  
R ch OUT

To MAIN  
CIRCUIT  
(CN102BA)  
On page 18

CN101B  
+B (2)  
SD  
ST EYE  
VT  
+B (1)  
GND

To MAIN  
CIRCUIT  
(CN101BA)  
On page 18

CN102B  
CL  
DO  
DI  
L ch OUT  
CE  
R ch OUT

To MAIN  
CIRCUIT  
(CN102BA)  
On page 18

Notes 2:

• Signal line

- : REC out signal (Lch)
- : AM (LW/MW) OSC signal
- : AM (LW/MW) signal
- : Positive voltage lines
- : Negative voltage lines
- : FM OSC signal
- : FM signal
- : AF signal (Lch)
- : Surround speaker drive signal
- : Center speaker drive signal

• Important safety notice

Components identified by  $\Delta$  mark have special characteristics important for safety. Furthermore, special parts which have purposes of fire-retardant (resistors), high-quality sound (capacitors), low-noise (resistors), etc. are used as occasion calls. When replacing any of components, be sure to use only manufacturer's specified parts shown in the parts list.

• All voltage values shown in circuitry are DC voltage in FM signal (Stereo mono) reception mode.

\* Figures in ( ) Stand for DC-voltage in MW signal reception mode.

\* Figures in < > Stand for DC-voltage in LW signal reception mode.

\* Figures in  $\square$  Stand for DC-voltage in muting mode.

• Caution!

- IC and LSI are sensitive to static electricity. Secondary trouble can be prevented by taking care during repair.
- Cover the parts boxes made of plastics with aluminum foil.
- Ground the soldering iron.
- Put a conductive mat on the work table.
- Do not touch the legs of IC or LSI with the fingers directly.

C MAIN CIRCUIT (PHONO EQ AMP/INPUT SELECTOR/ELECTOR VOLUME / BUFFER AMP/MUTING /REGULATOR)

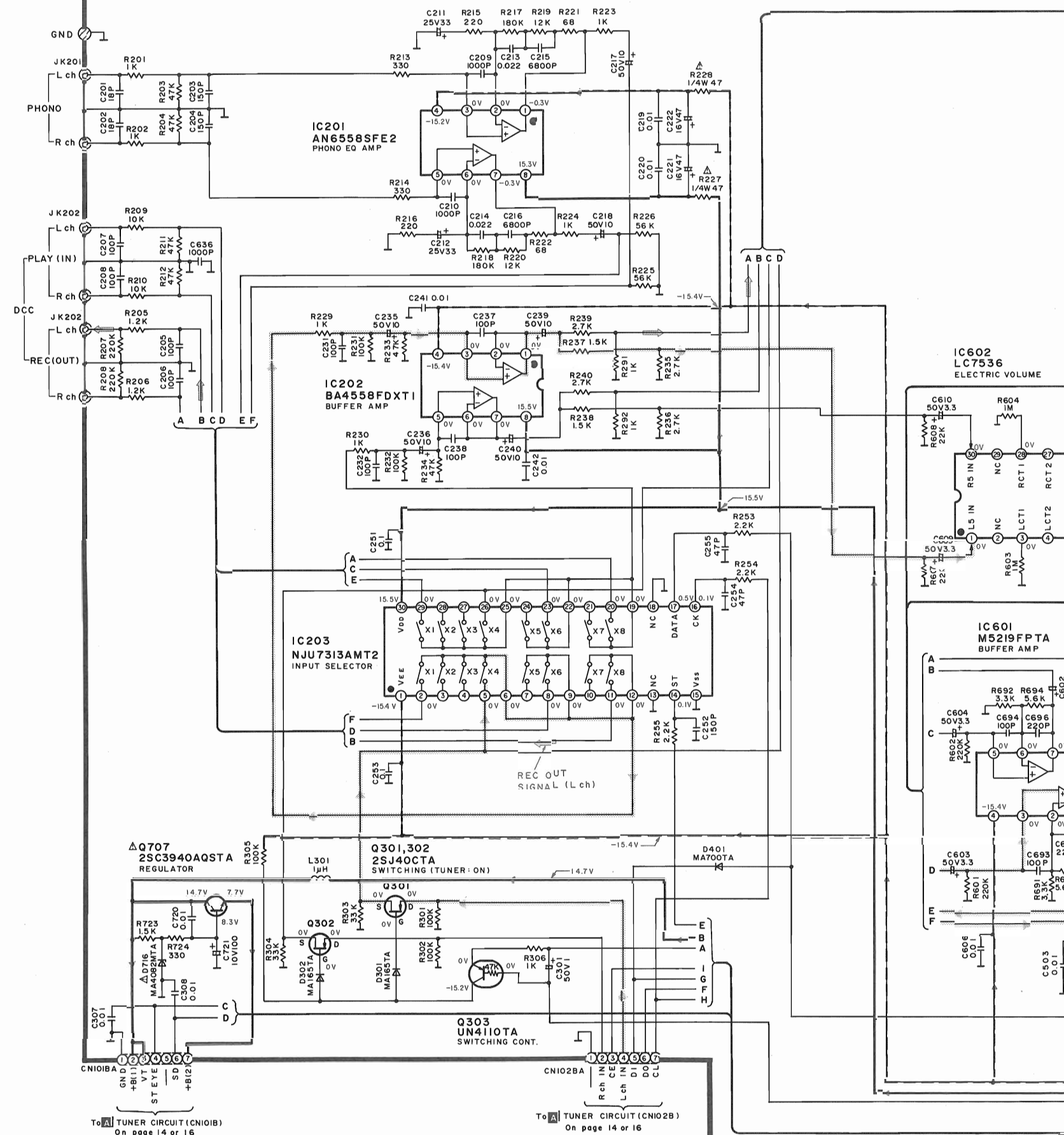

To A TUNER CIRCUIT (CN101B) On page 14 or 16

To A TUNER CIRCUIT (CN102B) On page 14 or 16

FFER AMP/MUTING/REGULATOR)

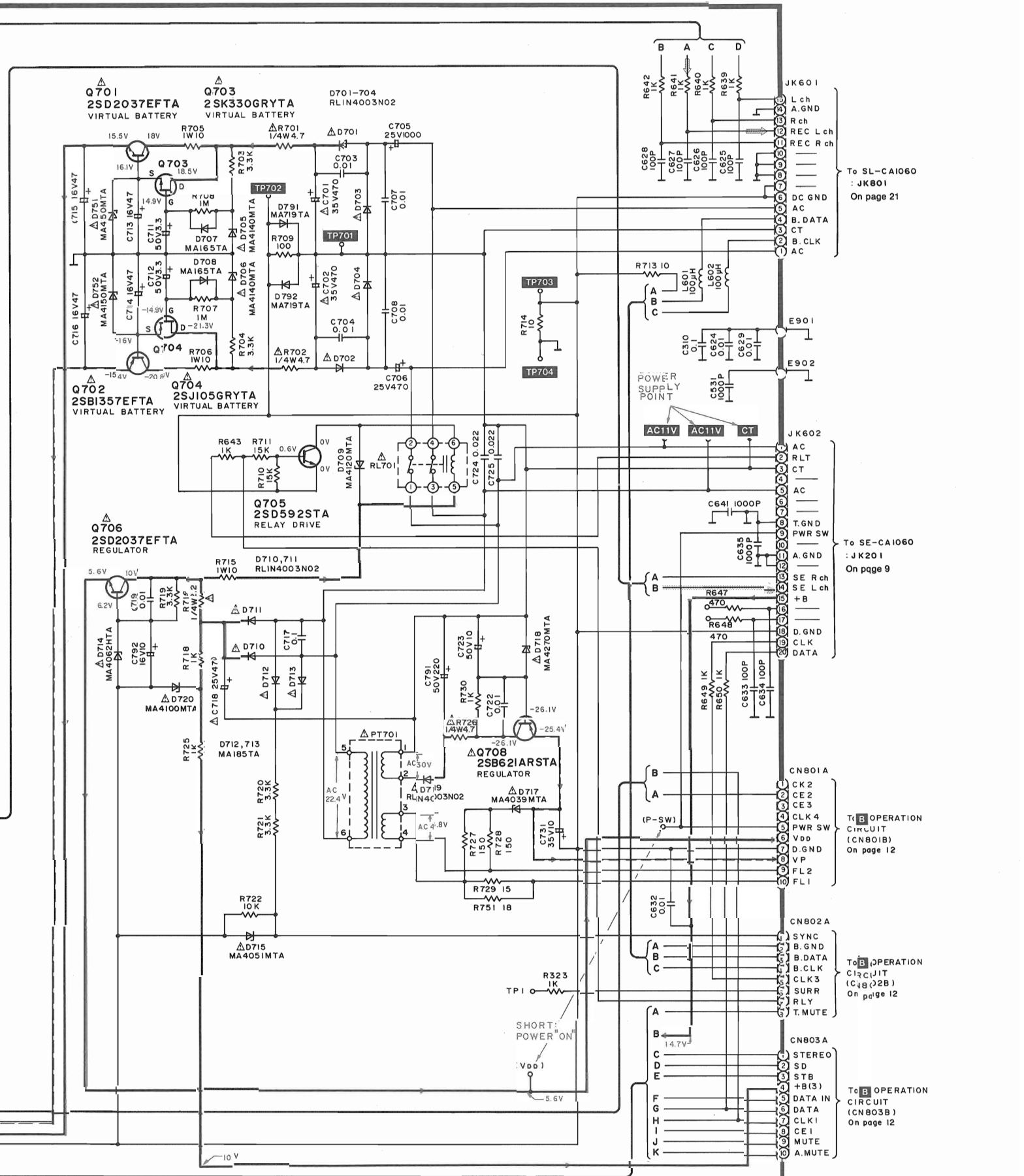
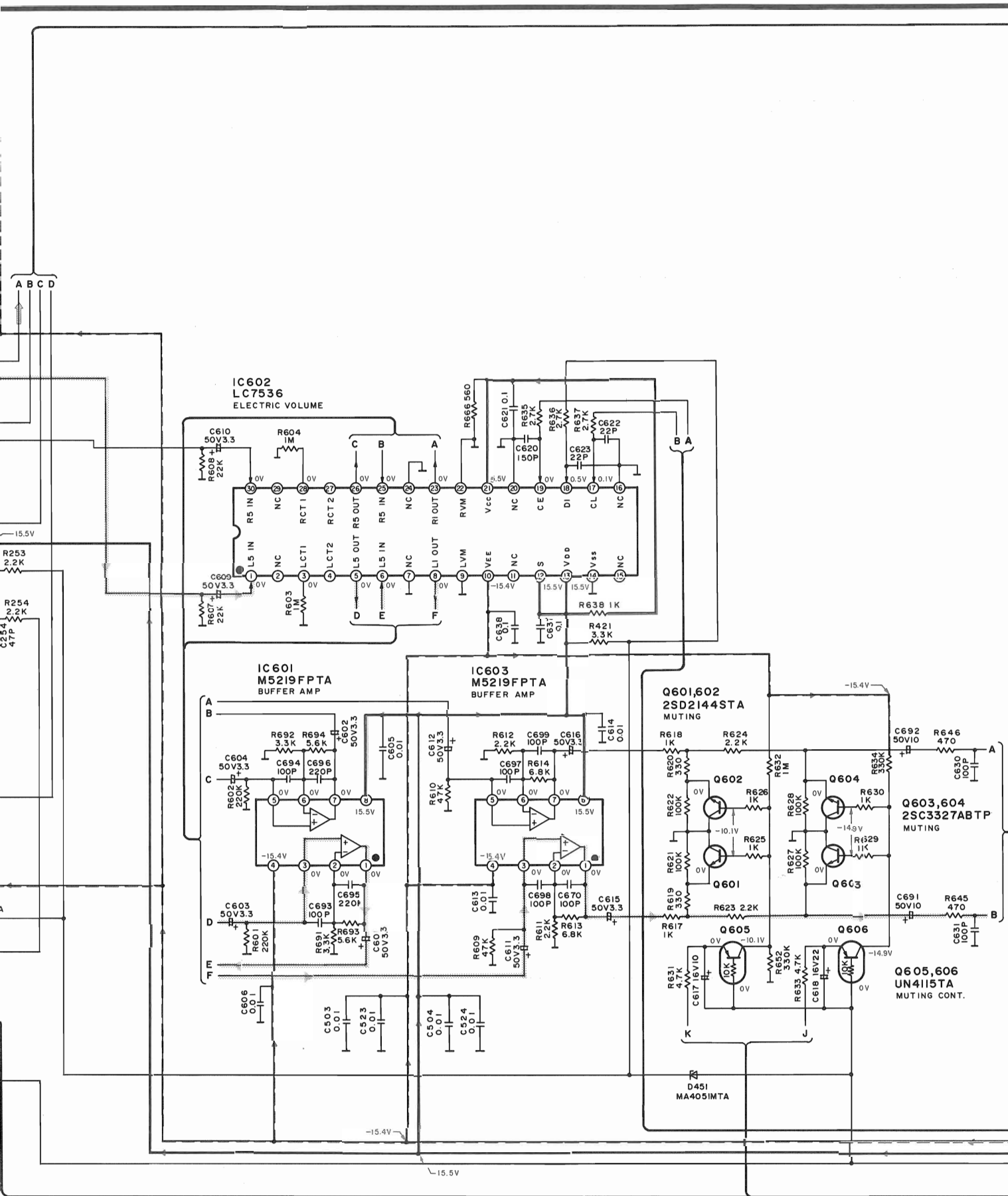

**BLOCK DIAGRAM**

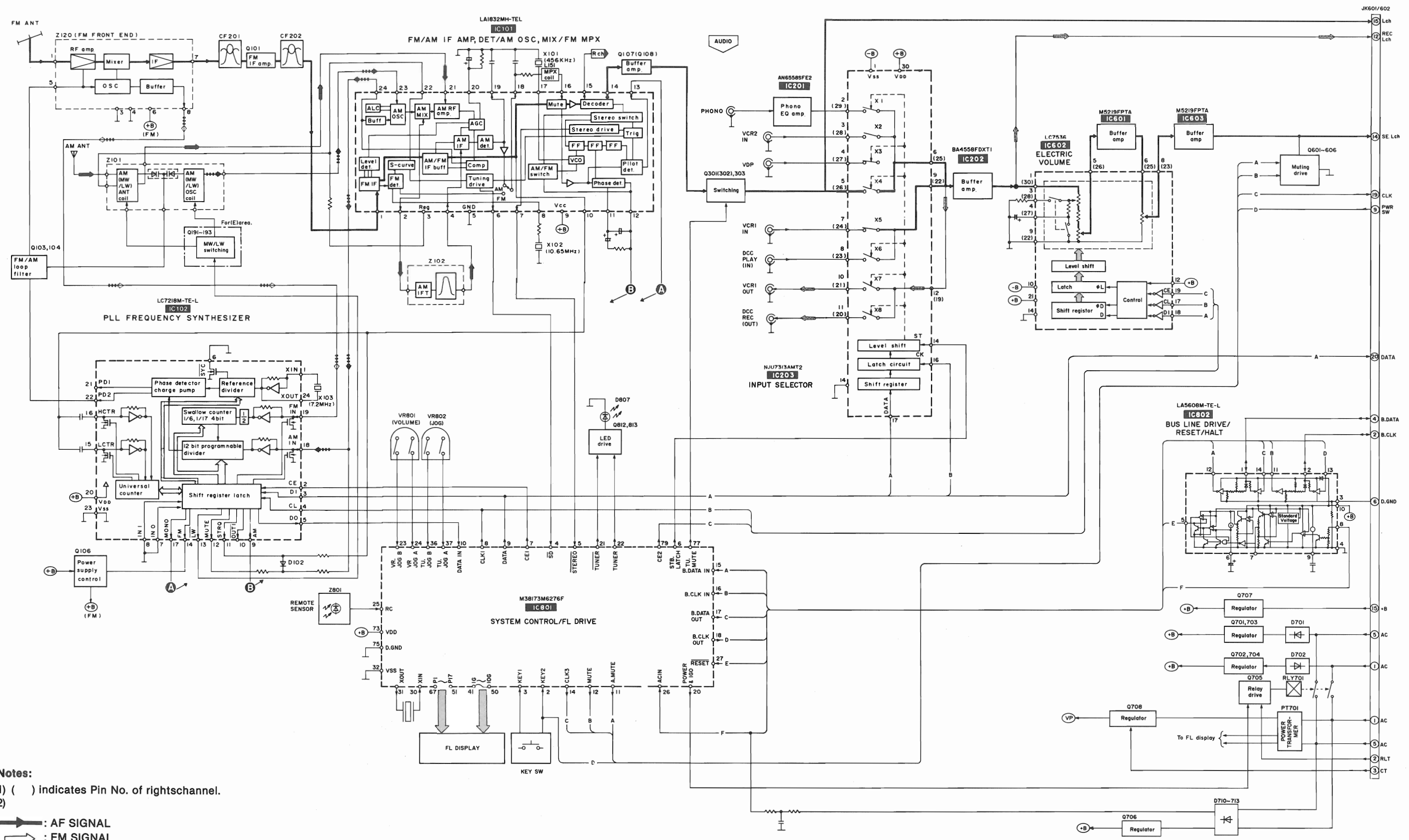

- Notes:**  
 1) ( ) indicates Pin No. of rightschannel.  
 2)
- ➔ : AF SIGNAL
  - ➔ : FM SIGNAL
  - ➔ : AM (LW/MW) SIGNAL
  - ⏏ : FM OSC SIGNAL
  - ⏏ : AM (LW/MW) SIGNAL
  - ➔ : REC OUT SIGNAL

PRINTED CIRCUIT BOARDS

A  
B  
C  
D  
E  
F  
G

C MAIN P.C.B. (REPI926A-M)

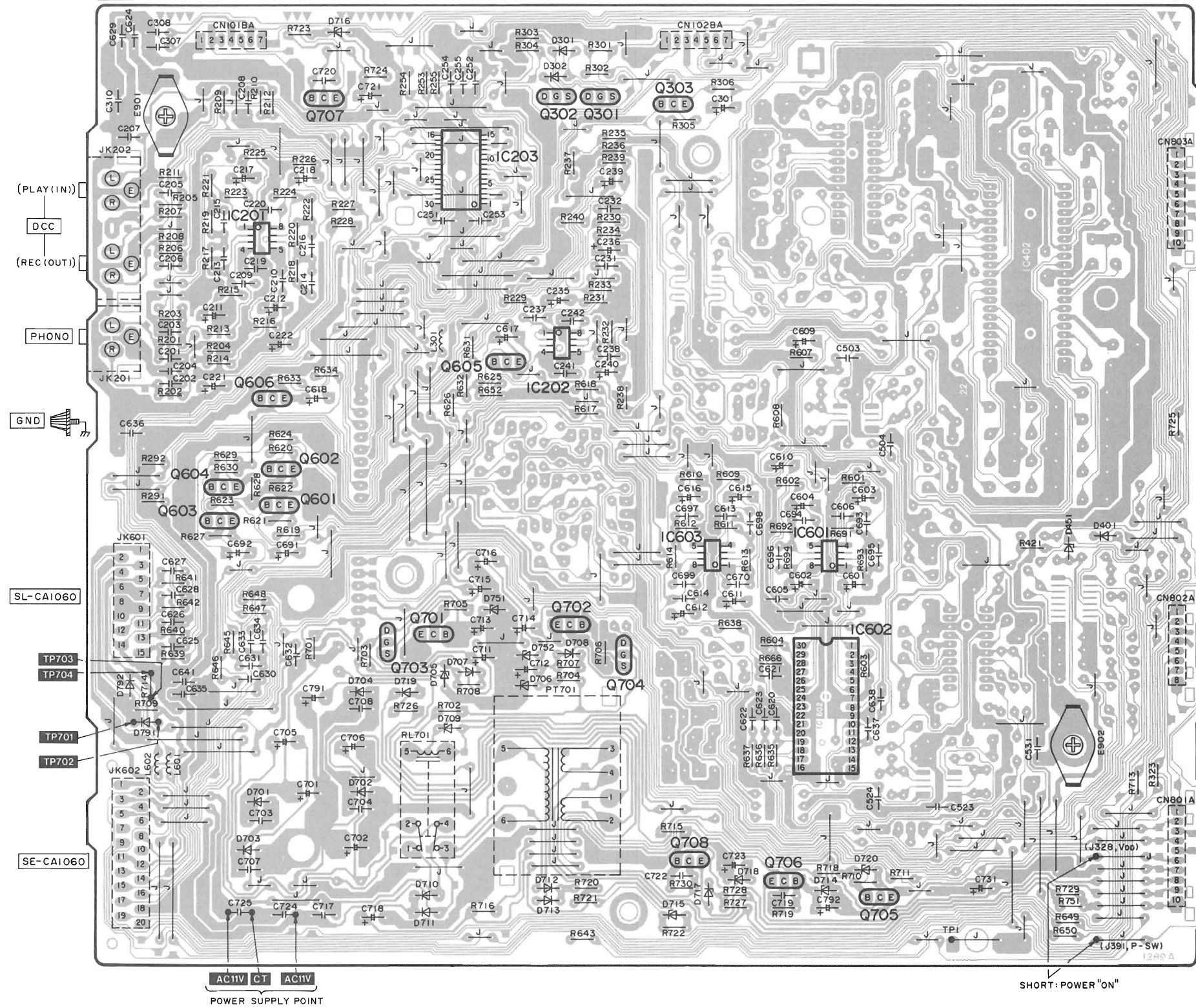



**A** TUNER P.C.B. For (E) area. (REPI930A-T)

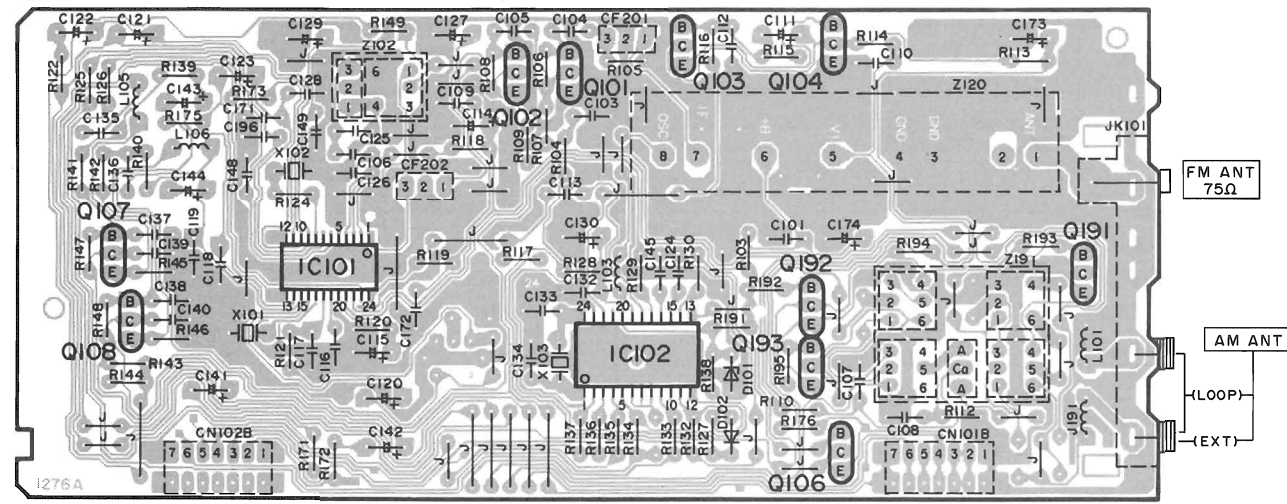

**A** TUNER P.C.B. For (EG) area. (REPI930B-T)

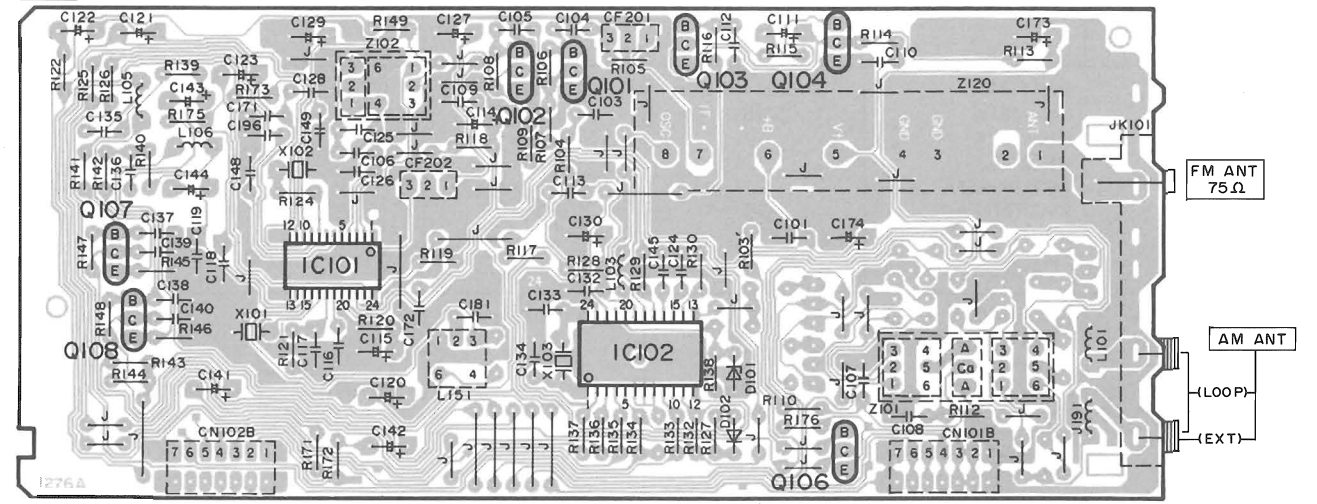

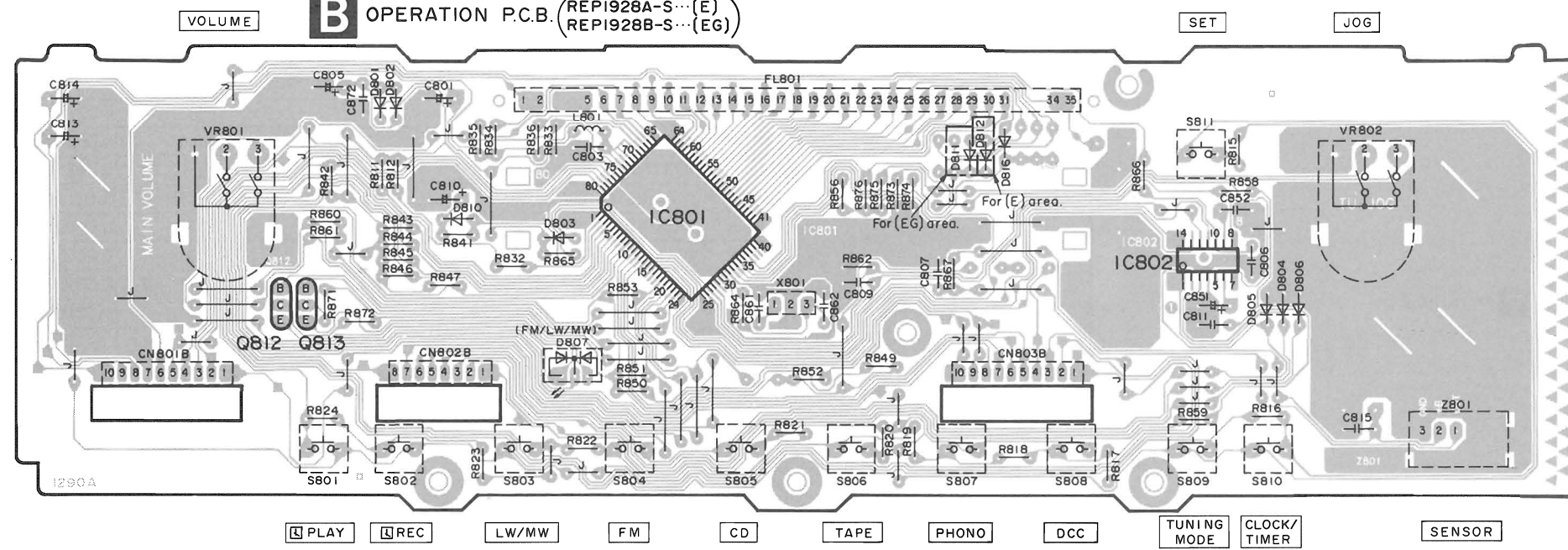

**B** OPERATION P.C.B. (REPI928A-S...(E)  
REPI928B-S...(EG))

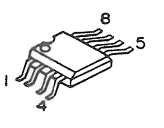
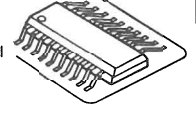
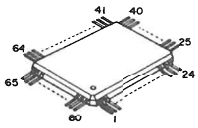
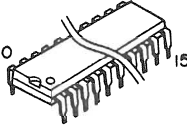
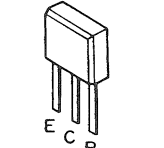
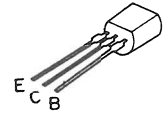
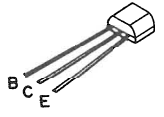
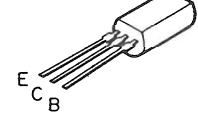

PLAY   
  REC   
 LW/MW   
 FM   
 CD   
 TAPE   
 PHONO   
 DCC   
 TUNING MODE   
 CLOCK/TIMER   
 SENSOR

## TERMINAL GUIDE OF IC'S, TRANSISTORS AND DIODES

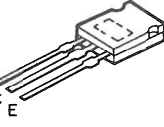
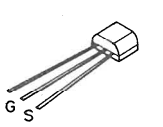
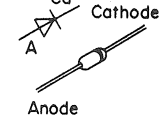
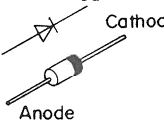
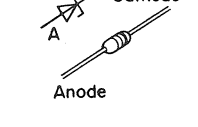
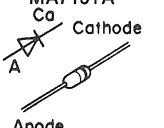
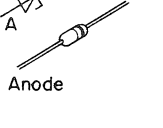
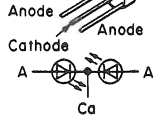
 BA4558FDXT1	 No.1 M5219FPTA 8 Pin AN6558SFE2 8 Pin LA5608M-TE-L 14 Pin LA1832MH-TEL 24 Pin LC7218M-TE-L 24 Pin NJU7313AMT2 30 Pin	 M38173M6276F	 LC7536	
 UN411FTA UN4110TA UN4115TA UN4216TA 2SC2785FETA 2SC2787LTA 2SC3311ARSTA	 2SB621ARSTA 2SD592STA	 2SC3327ABTP	 2SC3940AQSTA	 2SD2144STA
 2SB1357EFTA 2SD2037EFTA	 2SJ40CTA 2SJ105GRYTA 2SK330GRYTA	 MA165TA Cathode Anode	 RL1N4003N02 Cathode Anode	 MA4039MTA MA4051MTA MA4062HTA MA4082MTA Cathode Anode
 1SS291TA MA185TA MA700TA MA719TA Cathode Anode	 MA4100MTA MA4120MTA MA4140MTA MA4150MTA MA4270MTA Cathode Anode	 SPR-305MDTF Anode Cathode		

## WIRING CONNECTION DIAGRAM

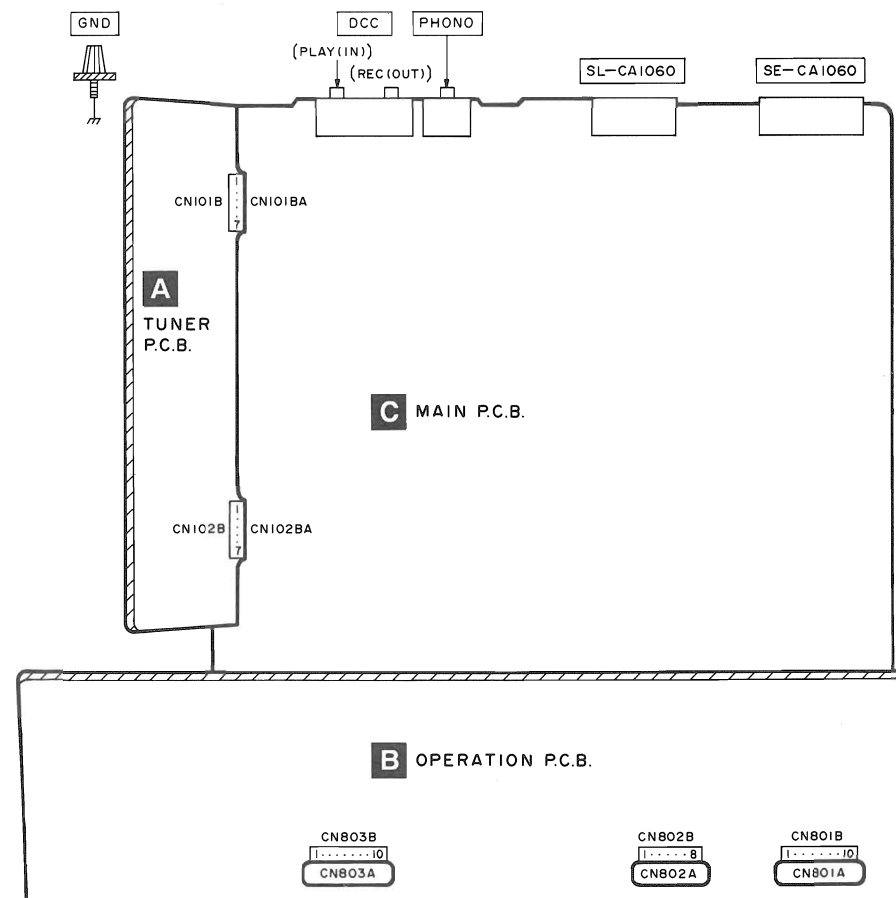

## REPLACEMENT PARTS LIST

**Notes:** \*Important safety notice:  
Components identified by  $\Delta$  mark have special characteristics important for safety.  
Furthermore, special parts which have purposes of fire-retardant (resistors), high-quality sound (capacitors), low-noise (resistors), etc. are used.  
When replacing any of components, be sure to use only manufacturer's specified parts shown in the parts list.  
\*The parenthesized indications in the Remarks columns specify the areas. (Refer to the cover page for area.)  
Parts without these indications can be used for all areas.

Ref. No.	Part No.	Part Name & Description	Remarks	Ref. No.	Part No.	Part Name & Description	Remarks
				D709	MA4120	DIODE	
		INTEGRATED CIRCUIT(S)		D710, 711	RL1N4003N02	DIODE	$\Delta$
				D712, 713	MA185TA	DIODE	$\Delta$
IC101	LA1832MH-TEL	FM/AM IF AMP./AM OSC		D714	MA4062-H	DIODE	$\Delta$
IC102	LC7218M-TE-L	PLL FREQ SYNTHESIZER		D715	MA4051MTA	DIODE	$\Delta$
IC201	AN6558SFE2	PHONO EQ AMP		D716	MA4082MTA	DIODE	$\Delta$
IC202	BA4558FDXT1	BUFFER AMP.		D717	MA4039MTA	DIODE	$\Delta$
IC203	NJU7313AMT2	INPUT SELECTOR		D718	MA4270	DIODE	$\Delta$
IC601	M5219FPTA	BUFFER AMP		D719	RL1N4003N02	DIODE	$\Delta$
IC602	LC7536	ELECTRONIC VOLUME		D720	MA4100MTA	DIODE	$\Delta$
IC603	M5219FPTA	BUFFER AMP		D751, 752	MA4150M	DIODE	$\Delta$
IC801	M38173M6276F	SYSTEM CONT./FL DRIVE		D791, 792	MA719TA	DIODE	
IC802	LA5608M-TE-L	BUS LINE/HALT/RESET		D801-803	1SS291TA	DIODE	
				D804-806	MA165	DIODE	
		TRANSISTOR(S)		D807	SPR-305MDTF	L. E. D.	
Q101, 102	2SC2787L	TRANSISTOR		D810	MA165	DIODE	
Q103, 104	2SC2785FE	TRANSISTOR		D811	MA165	DIODE	(EG)
Q106	UN411FTA	TRANSISTOR		D812	MA165	DIODE	(E)
Q107, 108	2SC3311ARSTA	TRANSISTOR		D816	MA165	DIODE	
Q191-193	2SC3311ARSTA	TRANSISTOR	(E)			VARIABLE RESISTOR(S)	
Q301, 302	2SJ40CTA	TRANSISTOR		VR801, 802	EVQW2BF2024B	VOLUME/JOG CONTROL	
Q303	UN4110TA	TRANSISTOR				COIL(S)	
Q601, 602	2SD2144S	TRANSISTOR					
Q603, 604	2SC3327-A	TRANSISTOR					
Q605, 606	UN4115	TRANSISTOR					
Q701	2SD2037EFTA	TRANSISTOR	$\Delta$	L101	ELESNR68MA	COIL	
Q702	2SB1357EFTA	TRANSISTOR	$\Delta$	L103	ELEXT47MA9	COIL	
Q703	2SK330GRYTA	TRANSISTOR	$\Delta$	L105, 106	ELELN822KL	COIL	
Q704	2SJ105GRYTA	TRANSISTOR	$\Delta$	L151	SLMLB10-1M	COIL	(EG)
Q705	2SD592NCR	TRANSISTOR		L191	ELESNR68MA	COIL	
Q706	2SD2037EFTA	TRANSISTOR	$\Delta$	L301	ELEXT1R0KA9	COIL	
Q707	2SC3940AQSTA	TRANSISTOR	$\Delta$	L601, 602	ELEXT101KA9	COIL	
Q708	2SB621A-R	TRANSISTOR	$\Delta$	L801	ELEXT1R0KA9	COIL	
Q812, 813	UN4216-S	TRANSISTOR				TRANSFORMER(S)	
		DIODE(S)		PT701	RTP114G004	POWER TRANSFORMER	$\Delta$
D101	MA4051MTA	DIODE	$\Delta$			COMPONENT COMBINATION(S)	
D102	MA165	DIODE					
D301, 302	MA165	DIODE					
D401	MA700TA	DIODE		Z101	RLA22002M-T	COMPONENT COMBINATION	(EG)
D451	MA4051MTA	DIODE		Z102	RLI22006M-T	COMPONENT COMBINATION	
D701-704	RL1N4003N02	DIODE	$\Delta$	Z191	RLA6Z005M-T	COMPONENT COMBINATION	(E)
D705, 706	MA4140M	DIODE	$\Delta$	Z801	RCDHC-278N	REMOTE SENSOR	
D707, 708	MA165	DIODE					

Ref. No.	Part No.	Part Name & Description	Remarks	Ref. No.	Part No.	Part Name & Description	Remarks
		FILTER(S)					
						JACK(S)	
CF201, 202	RLFFETWND01M	CERAMIC FILTER	(E)	JK101	RJH5210	ANTENNA TERMINAL	
CF201	RLFFETNGD01L	CERAMIC FILTER	(EG)	JK201	SJF3068-7N	PHONO	
CF202	RLFFETMGD01L	CERAMIC FILTER	(EG)	JK202	SJF3069-5N	DAT/DCC	
				JK601	RJT065K15	CONNECTOR(15P)	
		OSCILLATOR(S)		JK602	RJT065K20	CONNECTOR(20P)	
X101	RSXZ456KM07M	OSCILLATOR(456KHz)					
X102	RLFDGTD01I	OSCILLATOR(10. 7MHz)				EARTH TERMINAL(S)	
X103	RSXC7M20S04T	OSCILLATOR(7. 2MHz)					
X801	RSXA4M19S03	OSCILLATOR(4. 19MHz)		E901, 902	SNE1004-2	GND PLATE	
		DISPLAY TUBE(S)					
FL801	RSL0182-F	FL DISPLAY					
		FM FRONT END PACK ASS'Y(S)					
Z120	RAL0006	FM FRONT END	(E)				
Z120	RAL0019	FM FRONT END	(EG)				
		SWITCH(ES)					
S801	EVQ21405R	TIMER PLAY					
S802	EVQ21405R	TIMER REC					
S803	EVQ21405R	AM					
S804	EVQ21405R	FM					
S805	EVQ21405R	CD					
S806	EVQ21405R	TAPE					
S807	EVQ21405R	PHONO					
S808	EVQ21405R	DCC					
S809	EVQ21405R	TUNING MODE					
S810	EVQ21405R	CLOCK/TIMER MODE					
S811	EVQ21405R	CLOCK/TIMER SET					
		RELAY(S)					
RL701	RSY0017M-0	RELAY	△				
		CONNECTOR(S) AND SOCKET(S)					
CN101B	RJU057W007	SOCKET(7P)					
CN101BA	RJT057W007-1	CONNECTOR(7P)					
CN102B	RJU057W007	SOCKET(7P)					
CN102BA	RJT057W007-1	CONNECTOR(7P)					
CN801A	RJU003K010M1	SOCKET(10P)					
CN801B	RJT003K010-1	CONNECTOR(10P)					
CN802A	RJU003K008M1	SOCKET(8P)					
CN802B	RJT003K008-1	CONNECTOR(8P)					
CN803A	RJU003K010M1	SOCKET(10P)					
CN803B	RJT003K010-1	CONNECTOR(10P)					

# RESISTORS AND CAPACITORS

Notes : \* Capacity values are in microfarads (uF) unless specified otherwise, P=Pico-farads (pF) F=Farads (F)  
 \* Resistance values are in ohms, unless specified otherwise, 1K=1,000 (OHM), 1M=1,000k (OHM)

Ref. No.	Part No.	Values & Remarks	Ref. No.	Part No.	Values & Remarks	Ref. No.	Part No.	Values & Remarks
		RESISTORS	R194	ERDS2TJ122	1/4W 1.2K (E)	R645-648	ERDS2TJ471	1/4W 470
			R195	ERDS2TJ222	1/4W 2.2K (E)	R649, 650	ERDS2TJ102	1/4W 1K
			R201, 202	ERDS2TJ102	1/4W 1K	R652	ERDS2TJ334	1/4W 330K
R103	ERDS2TJ271	1/4W 270 (E)	R203, 204	ERDS2TJ473	1/4W 47K	R666	ERDS2TJ561	1/4W 560
R103	ERDS2TJ330	1/4W 33 (EG)	R205, 206	ERDS2TJ122	1/4W 1.2K	R691, 692	ERDS2TJ332	1/4W 3.3K
R104	ERDS2TJ822	1/4W 8.2K (E)	R207, 208	ERDS2TJ224T	1/4W 220K	R693, 694	ERDS2TJ562	1/4W 5.6K
R104	ERDS2TJ103	1/4W 10K (EG)	R209, 210	ERDS2TJ103	1/4W 10K	R701, 702	ERD2FCVJ4R7T	1/4W 4.7 $\Delta$
R105	ERDS2TJ471	1/4W 470	R211, 212	ERDS2TJ473	1/4W 47K	R703, 704	ERDS2TJ332	1/4W 3.3K
R106	ERDS2TJ474	1/4W 470K	R213, 214	ERDS2TJ331	1/4W 330	R705, 706	ERG1SJ100E	1W 10
R107	ERDS2TJ331	1/4W 330	R215, 216	ERDS2TJ221	1/4W 220	R707, 708	ERDS2TJ105T	1/4W 1M
R108	ERDS2TJ474	1/4W 470K	R217, 218	ERDS2TJ184T	1/4W 180K	R709	ERDS2TJ101	1/4W 100
R109	ERDS2TJ331	1/4W 330	R219, 220	ERDS2TJ123	1/4W 12K	R710, 711	ERDS2TJ153	1/4W 15K
R110	ERDS2TJ102	1/4W 1K	R221, 222	ERDS2TJ680T	1/4W 68	R713, 714	ERDS2TJ100	1/4W 10
R112	ERDS2TJ104	1/4W 100K	R223, 224	ERDS2TJ102	1/4W 1K	R715	ERG1SJ100E	1W 10
R113	ERDS2TJ103	1/4W 10K	R225, 226	ERDS2TJ563	1/4W 56K	R716	ERD25FJ2R2	1/4W 2.2 $\Delta$
R114	ERDS2TJ562	1/4W 5.6K	R227, 228	ERD25FJ470	1/4W 47 $\Delta$	R718	ERDS2TJ102	1/4W 1K
R115	ERDS2TJ561	1/4W 560	R229, 230	ERDS2TJ102	1/4W 1K	R719-721	ERDS2TJ332	1/4W 3.3K
R116	ERDS2TJ102	1/4W 1K	R231, 232	ERDS2TJ104	1/4W 100K	R722	ERDS2TJ103	1/4W 10K
R117	ERDS2TJ273	1/4W 27K (E)	R233, 234	ERDS2TJ473	1/4W 47K	R723	ERDS2TJ152	1/4W 1.5K
R117	ERDS2TJ823	1/4W 82K (EG)	R235, 236	ERDS2TJ272T	1/4W 2.7K	R724	ERDS2TJ331	1/4W 330
R118	ERDS2TJ562	1/4W 5.6K	R237, 238	ERDS2TJ152	1/4W 1.5K	R725	ERDS2TJ102	1/4W 1K
R119	ERDS2TJ682T	1/4W 6.8K (E)	R239, 240	ERDS2TJ272T	1/4W 2.7K	R726	ERD2FCVJ4R7T	1/4W 4.7 $\Delta$
R119	ERDS2TJ822	1/4W 8.2K (EG)	R253-255	ERDS2TJ222	1/4W 2.2K	R727, 728	ERDS2TJ151	1/4W 150
R120	ERDS2TJ473	1/4W 47K	R291, 292	ERDS2TJ102	1/4W 1K	R729	ERDS2TJ150T	1/4W 15
R121	ERDS2TJ332	1/4W 3.3K	R301, 302	ERDS2TJ104	1/4W 100K	R730	ERDS2TJ102	1/4W 1K
R122	ERDS2TJ272T	1/4W 2.7K	R303, 304	ERDS2TJ333	1/4W 33K	R751	ERDS2TJ180T	1/4W 18
R124	ERDS2TJ271	1/4W 270	R305	ERDS2TJ104	1/4W 100K	R811, 812	ERDS2TJ103	1/4W 10K
R125, 126	ERDS2TJ152	1/4W 1.5K	R306	ERDS2TJ102	1/4W 1K	R815	ERDS2TJ123	1/4W 12K
R127	ERDS2TJ103	1/4W 10K	R323	ERDS2TJ102	1/4W 1K	R816	ERDS2TJ682T	1/4W 6.8K
R128	ERDS2TJ820	1/4W 82	R421	ERDS2TJ332	1/4W 3.3K	R817	ERDS2TJ472	1/4W 4.7K
R129	ERDS2TJ473	1/4W 47K	R601, 602	ERDS2TJ224T	1/4W 220K	R818	ERDS2TJ332	1/4W 3.3K
R130	ERDS2TJ103	1/4W 10K	R603, 604	ERDS2TJ105T	1/4W 1M	R819	ERDS2TJ222	1/4W 2.2K
R132	ERDS2TJ103	1/4W 10K	R607, 608	ERDS2TJ223	1/4W 2.2K	R820	ERDS2TJ182	1/4W 1.8K
R133-137	ERDS2TJ102	1/4W 1K	R609, 610	ERDS2TJ473	1/4W 47K	R821	ERDS2TJ152	1/4W 1.5K
R138	ERDS2TJ103	1/4W 10K	R611, 612	ERDS2TJ222	1/4W 2.2K	R822	ERDS2TJ182	1/4W 1.8K
R139, 140	ERDS2TJ272T	1/4W 2.7K	R613, 614	ERDS2TJ682T	1/4W 6.8K	R823	ERDS2TJ102	1/4W 1K
R141, 142	ERDS2TJ102	1/4W 1K	R617, 618	ERDS2TJ102	1/4W 1K	R824	ERDS2TJ821	1/4W 820
R143, 144	ERDS2TJ222	1/4W 2.2K	R619, 620	ERDS2TJ331	1/4W 330	R832	ERDS2TJ471	1/4W 470
R145, 146	ERDS2TJ102	1/4W 1K (E)	R621, 622	ERDS2TJ104	1/4W 100K	R833	ERDS2TJ102	1/4W 1K
R145, 146	ERDS2TJ821	1/4W 820 (EG)	R623, 624	ERDS2TJ222	1/4W 2.2K	R834-836	ERDS2TJ104	1/4W 100K
R147, 148	ERDS2TJ474	1/4W 470K	R625, 626	ERDS2TJ102	1/4W 1K	R841	ERDS2TJ224T	1/4W 220K
R149	ERDS2TJ680T	1/4W 68	R627, 628	ERDS2TJ104	1/4W 100K	R842, 843	ERDS2TJ393	1/4W 39K
R171, 172	ERDS2TJ102	1/4W 1K	R629, 630	ERDS2TJ102	1/4W 1K	R844-846	ERDS2TJ102	1/4W 1K
R173	ERDS2TJ471	1/4W 470	R631	ERDS2TJ472	1/4W 4.7K	R847	ERDS2TJ222	1/4W 2.2K
R175	ERDS2TJ102	1/4W 1K	R632	ERDS2TJ105T	1/4W 1M	R849	ERDS2TJ392T	1/4W 3.9K
R176	ERDS2TJ391	1/4W 390	R633	ERDS2TJ472	1/4W 4.7K	R850, 851	ERDS2TJ102	1/4W 1K
R191	ERDS2TJ103	1/4W 10K (E)	R634	ERDS2TJ334	1/4W 330K	R852	ERDS2TJ392T	1/4W 3.9K
R192	ERDS2TJ122	1/4W 1.2K (E)	R635-637	ERDS2TJ272T	1/4W 2.7K	R853	ERDS2TJ103	1/4W 10K
R193	ERDS2TJ182	1/4W 1.8K (E)	R638-643	ERDS2TJ102	1/4W 1K	R854	ERDS2TJ103	1/4W 10K

Ref. No.	Part No.	Values & Remarks	Ref. No.	Part No.	Values & Remarks	Ref. No.	Part No.	Values & Remarks
R858, 859	ERDS2TJ102	1/4W 1K	C181	ECBT1H471KB5	50V 470P (EG)	C703, 704	ECKR1H103ZF5	50V 0.01U
R860, 861	ERDS2TJ223	1/4W 22K	C196	ECBT1H102KB5	50V 1000P	C705	ECA1EM102B	25V 1000U
R862	ERDS2TJ333	1/4W 33K	C201, 202	ECBT1H180J5	50V 18P	C706	ECA1EM471B	25V 470U
R864	ERDS2TJ221	1/4W 220	C203, 204	ECBT1H151KB5	50V 150P	C707, 708	ECKR1H103ZF5	50V 0.01U
R865	ERDS2TJ104	1/4W 100K	C205-208	ECBT1H101KB5	50V 100P	C711, 712	ECA1HAP3R3B	50V 3.3U
R866	ERDS2TJ470	1/4W 47	C209, 210	ECBT1H102KB5	50V 1000P	C713-716	ECA1CAP470B	16V 47U
R867	ERDS2TJ223	1/4W 22K	C211, 212	ECA1EAP330B	25V 33U	C717	ECBT1H104ZF5	50V 0.1U
R871, 872	ERDS2EJ121	1/4W 120	C213, 214	ECQB1H223JF3	50V 0.022U	C718	RCE1EM471BV	25V 470U $\Delta$
R873, 874	ERDS2TJ103	1/4W 10K	C215, 216	ECBT1C682KR5	16V 6800P	C719, 720	ECBT1E103ZF	25V 0.01U
R875, 876	ERDS2TJ223	1/4W 22K	C217, 218	ECA1HAP100B	50V 10U	C721	ECEA1KA101B	10V 100U
			C219, 220	ECBT1E103ZF	25V 0.01U	C722	ECBT1E103ZF	25V 0.01U
		CAPACITORS	C221, 222	ECEA1CKA470B	16V 47U	C723	ECEA1HKA100B	50V 10U
			C231, 232	ECBT1H101KB5	50V 100P	C724, 725	ECKT1H223ZF	50V 0.022U
C101	ECBT1C103NS5	16V 0.01U	C235, 236	ECA1HAP100B	50V 10U	C731	ECEA1VKA100B	35V 10U
C103	ECBT1C103NS5	16V 0.01U	C237, 238	ECBT1H101KB5	50V 100P	C791	RCE1HM221BV	50V 220U
C104, 105	ECBT1H102KB5	50V 1000P	C239, 240	ECA1HAP100B	50V 10U	C792	ECEA1CKA100B	16V 10U
C106	ECBT1C103NS5	16V 0.01U	C241, 242	ECBT1E103ZF	25V 0.01U	C801	ECEAOJU102	6.3V 1000U
C107	ECBT1H473ZF5	50V 0.047U	C251	ECBT1H104ZF5	50V 0.1U	C803	ECBT1H104ZF5	50V 0.1U
C108	ECBT1H100JC5	50V 10P (E)	C252	ECBT1H151KB5	50V 150P	C805	ECEAOJKA101B	6.3V 100U
C108	ECBT1H8RZJC5	50V 8.2P (EG)	C253	ECBT1H104ZF5	50V 0.1U	C806	ECBT1E223ZF	25V 0.022U
C109, 110	ECBT1C103NS5	16V 0.01U	C254, 255	ECBT1H470J5	50V 47P	C807	ECBT1H102KB5	50V 1000P
C111	ECEA1EKA4R7B	25V 4.7U	C301	ECEA1HKA010B	50V 1U	C809	ECBT1E103ZF	25V 0.01U
C112	ECBT1C103NS5	16V 0.01U	C307, 308	ECBT1C103NS5	16V 0.01U	C810	ECEA1CKA100B	16V 10U
C113	ECBT1H102KB5	50V 1000P	C310	ECQV1H104JM3	50V 0.1U	C811	ECBT1E103ZF	25V 0.01U
C114	ECEA1HKA3R3B	50V 3.3U	C503, 504	ECBT1E103ZF	25V 0.01U	C813, 814	ECEA1HKA010B	50V 1U
C115	ECEA1EKA4R7B	25V 4.7U	C523, 524	ECBT1E103ZF	25V 0.01U	C815	ECBT1E103ZF	25V 0.01U
C116	ECBT1C822KS5	16V 8200P	C531	ECBT1H102KB5	50V 1000P	C851	ECEA1HKAR33B	50V 0.33U
C117	ECQB1H102JF3	50V 1000P (E)	C601-604	ECA1HAP3R3B	50V 3.3U	C852	ECQV1H104JM3	50V 0.1U
C117	ECQB1H561JF3	50V 560P (EG)	C605, 606	ECBT1E103ZF	25V 0.01U	C861	ECBT1H220GC5	50V 22P
C118, 119	ECFR1C103KB	16V 0.01U	C609-612	ECA1HAP3R3B	50V 3.3U	C862	ECBT1H270JU5	50V 27P
C120, 121	ECEA1HKA010B	50V 1U	C613, 614	ECBT1E103ZF	25V 0.01U	C872	ECBT1E103ZF	25V 0.01U
C122	ECEA1HKA2R2B	50V 2.2U	C615, 616	ECA1HAP3R3B	50V 3.3U			
C123	ECEA1HKA010B	50V 1U	C617	ECEA1CKA100B	16V 10U			
C124	ECBT1H102KB5	50V 1000P	C618	ECEA1CKA220B	16V 22U			
C125	ECBT1H150JC5	50V 15P	C620	ECBT1H151KB5	50V 150P			
C126	ECBT1H473ZF5	50V 0.047U	C621	ECBT1H104ZF5	50V 0.1U			
C127	ECEA1CKA220B	16V 22U	C622, 623	ECBT1H220J5	50V 22P			
C128	ECBT1H102KB5	50V 1000P	C624	ECBT1E103ZF	25V 0.01U			
C129, 130	ECEAOJKA101B	6.3V 100U	C625-628	ECBT1H101KB5	50V 100P			
C132	ECBT1H102KB5	50V 1000P	C629	ECBT1E103ZF	25V 0.01U			
C133, 134	ECBT1H270JU5	50V 27P	C630, 631	ECBT1H101KB5	50V 100P			
C135, 136	ECBT1C103KS5	16V 0.01U	C632	ECBT1E103ZF	25V 0.01U			
C137, 138	ECBT1H561KB5	50V 560P	C633, 634	ECBT1H101KB5	50V 100P			
C139, 140	ECBT1C682KR5	16V 6800P (E)	C635, 636	ECBT1H102KB5	50V 1000P			
C139, 140	ECBT1C682KR5	16V 6800P (EG)	C637, 638	ECBT1H104ZF5	50V 0.1U			
C141-144	ECEA1HKA010B	50V 1U	C641	ECBT1H102KB5	50V 1000P			
C145	ECBT1H220JC5	50V 22P	C670	ECBT1H101KB5	50V 100P			
C148	ECBT1C103NS5	16V 0.01U	C691, 692	ECA1HAP100B	50V 10U			
C149	ECBT1H104ZF5	50V 0.1U	C693, 694	ECBT1H101KB5	50V 100P			
C171, 172	ECBT1H102KB5	50V 1000P	C695, 696	ECBT1H221KB5	50V 220P			
C173	ECEA1CKA220B	16V 22U	C697-699	ECBT1H101KB5	50V 100P			
C174	ECEA1CKA100B	16V 10U	C701, 702	ECA1VM471B	35V 470U $\Delta$			

1 2 3 4 5

# CABINET PARTS LOCATION

A  
B  
C  
D  
E  
F  
G

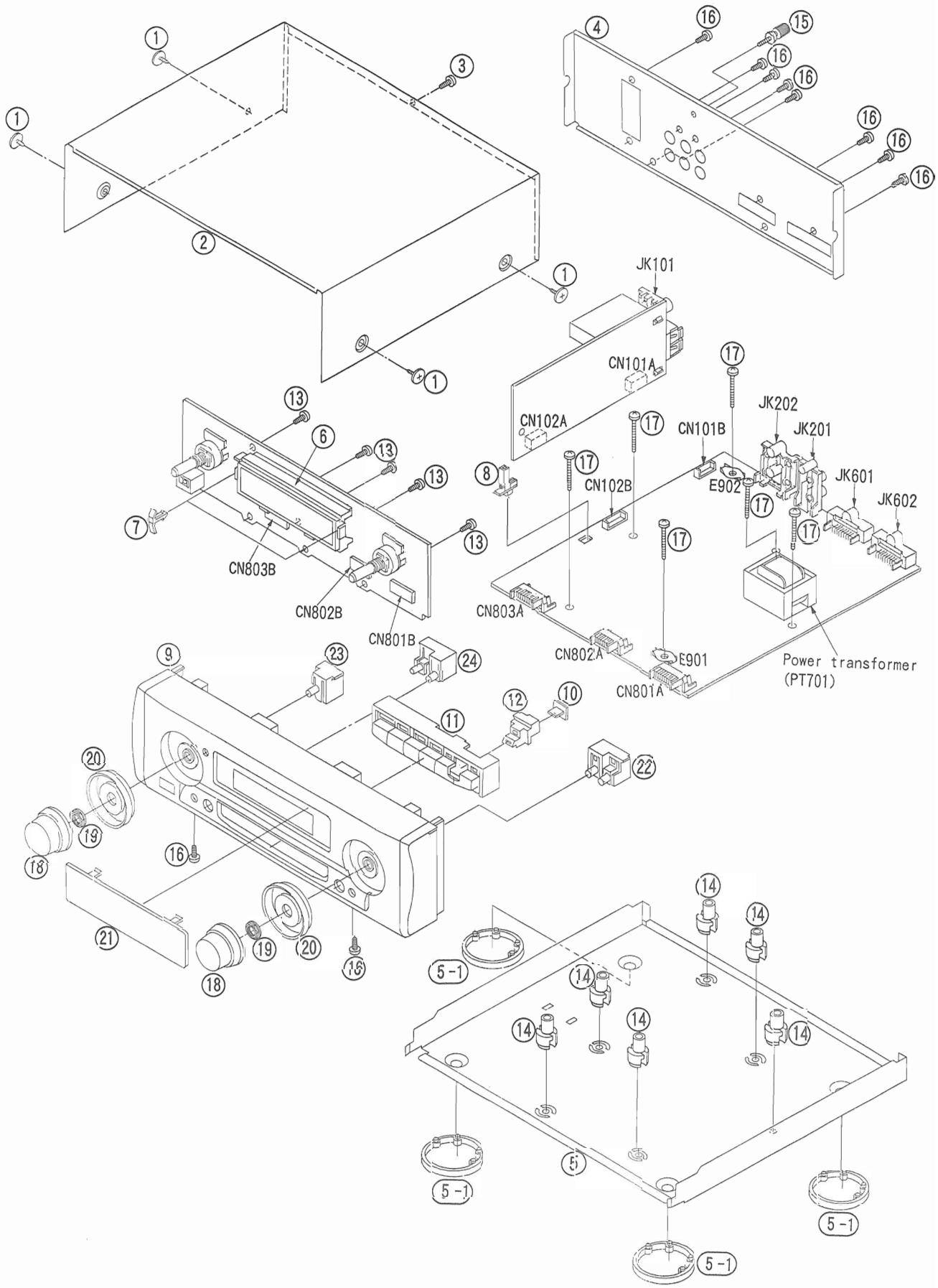

## REPLACEMENT PARTS LIST

Notes: \*The parenthesized indications in the Remarks columns specify the areas. (Refer to the cover page for area.) Parts without these indications can be used for all areas.

Ref. No.	Part No.	Part Name & Description	Remarks	Ref. No.	Part No.	Part Name & Description	Remarks
		CABINET AND CHASSIS					
1	RHD30007	SCREW					
2	RKM0203A-2K	CABINET					
3	XTB3+8JFZ	SCREW					
4	RGR0194A-A2	REAR PANEL	(E)				
4	RGR0194A-B	REAR PANEL	(EG)				
5	RFKJSCH404EK	BOTTOM BOARD ASS'Y					
5-1	RKA0011-3	FOOT					
6	RMN0194	FL. HOLDER					
7	RMN0195	FL. SPACER					
8	RMN0203	P. C. B. HOLDER					
9	RFKGTCA1060E	FRONT PANEL ASS'Y					
10	RGL0237-Q	PANEL LIGHT					
11	RFKNT1060EA	INPUT SELECT BUTTON ASS'Y	(E)				
11	RFKNT1060EGA	INPUT SELECT BUTTON ASS'Y	(EG)				
12	RFKNT1060EB	PANEL LIGHT BUTTON ASS'Y	(E)				
12	RFKNT1060EGB	PANEL LIGHT BUTTON ASS'Y	(EG)				
13	XTBS26+8J	SCREW					
14	SHE185-2	P. C. B. SPACER					
15	SNE2123	SCREW					
16	XTBS3+8JFZ1	SCREW					
17	XTB3+16JFZ	SCREW					
18	RGW0206-K	VOLUME KNOB					
19	RHN90001	NUT					
20	RGK0644-S	VOLUME ORNAMENT					
21	RKW0342-V	FL. PANEL					
22	RFKNT1060EC	REC/PLAY TIMER BUTTON ASS'Y					
23	RFKNT1060ED	SET BUTTON ASS'Y					
24	RFKNT1060EE	CLOCK/TUN. MODE BUTTON ASS'Y					