

# Service Manual

Tuner/Sound Processor

Tuner

## ST-CH505

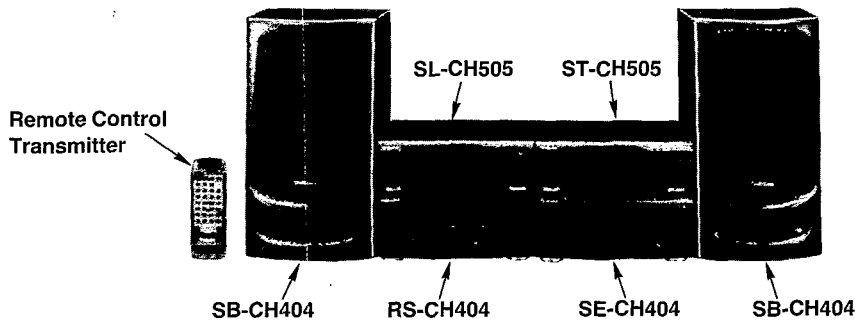

Because of unique interconnecting cables, when a component requires service, send or bring in the entire system.

Colour

(K) .... Black Type

## Areas

Suffix for Model No.	Area	Colour
(E)	Europe	(K)
(EG)	Germany and Italy	
(GN)	Oceania	

System: SC-CH404

### Specifications

#### Pre-amplifier section

Input sensitivity/impedance  
PHONO for (E) (EG) areas

2.5 mV/47 k $\Omega$ 

AUX for (GN) area

250 mV/15 k $\Omega$ 

DCC

250 mV/15 k $\Omega$ 

Output level

DCC RECOUT

150 mV/1.5 k $\Omega$ 

Frequency response

PHONO for (E) (EG) areas

30 Hz–15 kHz/+1.5 to –2.0 dB

AUX for (GN) area

30 Hz–20 kHz

DCC

30 Hz–20 kHz

#### EQ, SFP section

Center frequency

80, 250, 1 k, 4 k, 12.5 k(Hz)

Fixed mode

SPACE

3 modes (DISCO, LIVE, HALL)

GEQ

5 modes

(HEAVY, CLEAR, SOFT, CAR, HP ST)

#### FM tuner section

Frequency range

87.50–108.00 MHz (0.05 MHz steps)

Sensitivity

1.8  $\mu$ V (IHF usable)

S/N 26 dB

1.5  $\mu$ V (75 $\Omega$ )

S/N

MONO 70 dB (75 dB, IHF)

Stereo separation 1 kHz

35 dB

Antenna terminal(s)

75 $\Omega$  (unbalance)

#### AM tuner section

Frequency range

MW

522–1611 kHz (9 kHz step)

530–1620 kHz (10 kHz step)

LW

144–288 kHz (9 kHz step)

Sensitivity (S/N 20 dB)

MW

500  $\mu$ V/m

LW

50  $\mu$ V

#### Timer section

Clock

Quartz-lock type

Function

24-hour programmable;

Play timer (1 time), Rec timer (1 time),

Sleep (120 min, 1 min intervals)

Setting

1 minute–23 hours 59 minutes

(1 min, intervals)

#### General

Dimensions (W×H×D)

270×89×274 mm

Weight

1.75 kg

#### Notes:

- Weights and dimensions shown are approximate.
- Design and specifications are subject to change without notice.

System	Tuner	Compact disc player	Amplifier	Cassette deck	Speakers
SC-CH404	ST-CH505	SL-CH505	SE-CH404	RS-CH404	SB-CH404 *1(E) (EG) areas *2(GN) area

\*1Made in PAES

\*2Made in NABEL

# Technics

## ■ Contents

	Page		Page
● LOCATION OF CONTROLS .....	2	● WIRING CONNECTION DIAGRAM .....	18
● SETTING THE TIME .....	3	● BLOCK DIAGRAM .....	19~21
● DISASSEMBLY INSTRUCTIONS .....	4~6	● FUNCTION OF IC TERMINALS .....	22
● POWER SUPPLY WITH TUNER ST-CH505 .....	6	● REPLACEMENT PARTS LIST .....	23~27
● SCHEMATIC DIAGRAM .....	7~14	● CABINET PARTS LOCATION .....	28
● PRINTED CIRCUIT BOARD DIAGRAM .....	15~18		

### NOTE:

Refer to the service manual for Model No. SE-CH404 (Order No. AD9307218C8) for information on "ACCESSORIES", "STACKING THE COMPONENTS", "CONNECTIONS" and "PACKAGING".

## ■ Location of Controls

The functions indicated by the numbers with black background (for example ③) can also be activated from the remote control.

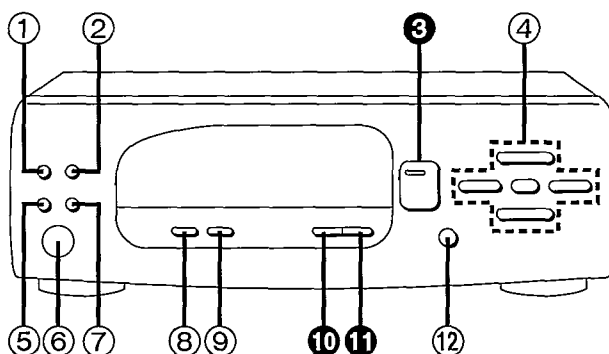

No.	Name
①	External source input select button (EXT)
②	Internal source input select button (INT)
③	Tuner source/band select button and indicator (TUNER/BAND)
④	Multi-control buttons (MULTI CONTROL)
⑤	Record timer button (REC)
⑥	Remote control signal sensor (SENSOR)

No.	Name
⑦	Play timer button (PLAY)
⑧	V.bass button (V.BASS)
⑨	Voice mute button (KARAOKE)
⑩	EQ/SPACE mode ON/FLAT button (ON/FLAT)
⑪	EQ/SPACE mode select button (MODE)
⑫	Clock/timer button (CLOCK/TIMER)

## Setting the Time

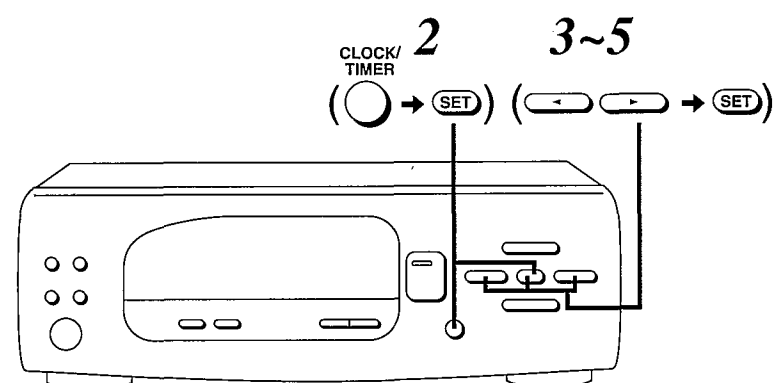

These instructions explain how to set the timer for 16:25 (4:25 p.m.) on Wednesday.

- 1** **Switch on the power on the amplifier.**

STANDBY ON
- 2** **Press CLOCK/TIMER to select "CLOCK".**

CLOCK

within 7 seconds:  
**2** Press SET.
- 3** **Press ◀ or ▶ to select "WED".**

WED 000

**2** Press SET.
- 4** **Press ◀ or ▶ to select "16".**

WED 16:00

**2** Press SET.

- 5** **Press ◀ or ▶ to select "25".**

WED 16:25

**2** Press SET to finish setting the time.  
The display will return to the previous display after about 2 seconds.

### When "E:" appears on the display:

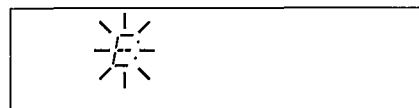

It appears when you connect the power supply cord for the first time or if there has been a power failure. If this happens, reset the time.

### If the minutes setting has gone wrong:

1. Press CLOCK/TIMER.
2. Press SET 3 times.
3. Press one of SELECT to set the minute, and then press SET.

### For your reference:

To display the clock again:  
Press CLOCK/TIMER.  
The clock display will appear for about 5 seconds.

## Disassembly Instructions

### "ATTENTION SERVICER"

Some chassis components may have sharp edges. Be careful when disassembling and servicing.

Ref. No. 1	Removal of the Cabinet	Ref. No. 2	Removal of the Front Panel Ass'y
Procedure 1	<p>1. Remove the 5 screws (1~5). 2. Remove the cabinet in the direction of arrow.</p>	Procedure 1→2	<p>1. Remove the 2 screws (1, 2). 2. Remove the front panel ass'y in the direction of arrow.</p>
Ref. No. 3	Removal of the Operation P.C.B.	Ref. No. 4	Removal of the Rear Panel
Procedure 1→2→3	<p>• Remove the 7 screws (1~7).</p>	Procedure 1→4	<p>1. Remove the 8 screws (1~8). 2. Pull the rear panel in both directions of arrow ① to unlock it from the projection of the bottom board ass'y. 3. Remove the rear panel in the direction of arrow ②.</p>
Ref. No. 5	Removal of the Connection (1) P.C.B., Connection (2) P.C.B. and Tuner P.C.B.		
Procedure 1→4→5	<p>1. Release the 1 claw. 2. Lift up the tuner P.C.B. in the direction of arrow ①, and then remove the 2 connectors (CN201A/B, CN202A/B).</p>	<p>3. Remove the connection (1) P.C.B. and connection (2) P.C.B. in the direction of arrow ②.</p>	

**Ref. No. 6**  
**Removal of the Main P.C.B.**
**Procedure**  
 1→2→4→5→6

- Remove the 5 screws (1~5).

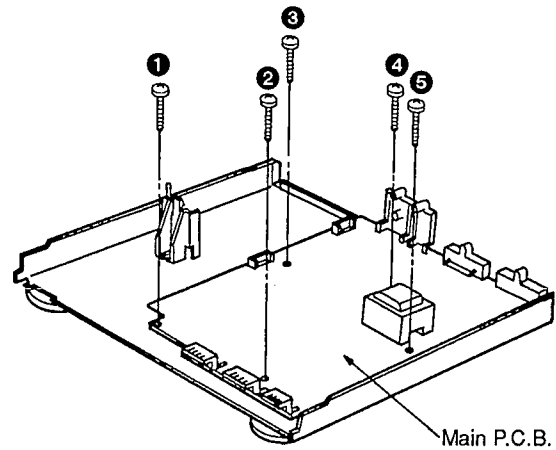
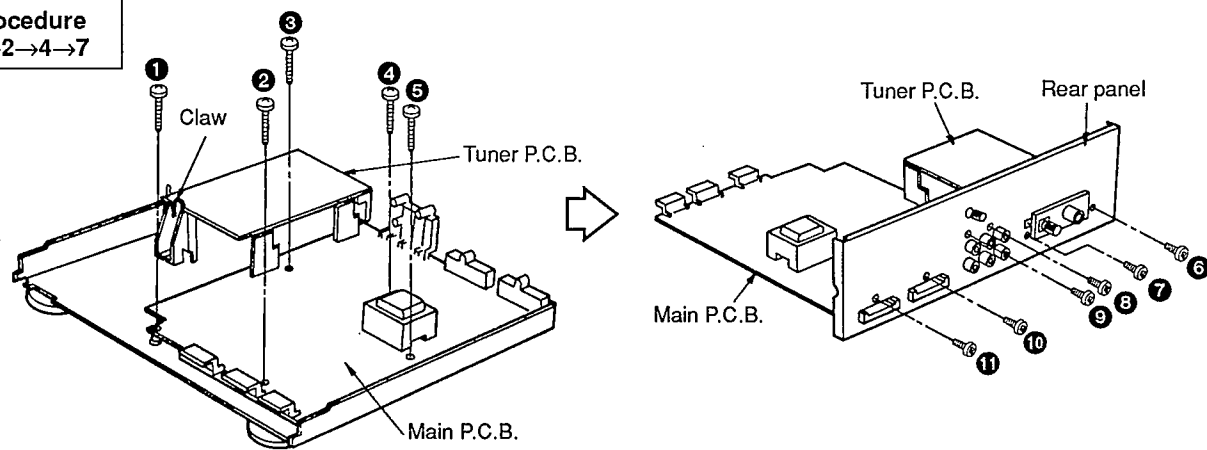
**Ref. No. 7**  
**How to check the Main P.C.B.**
**Procedure**  
 1→2→4→7

- Remove the 5 screws (1~5).
- Release the 1 claw.
- Remove the main P.C.B. and tuner P.C.B.

- Reinstall the rear panel to the main P.C.B. and tuner P.C.B. and then tighten 6 screws (6~11).

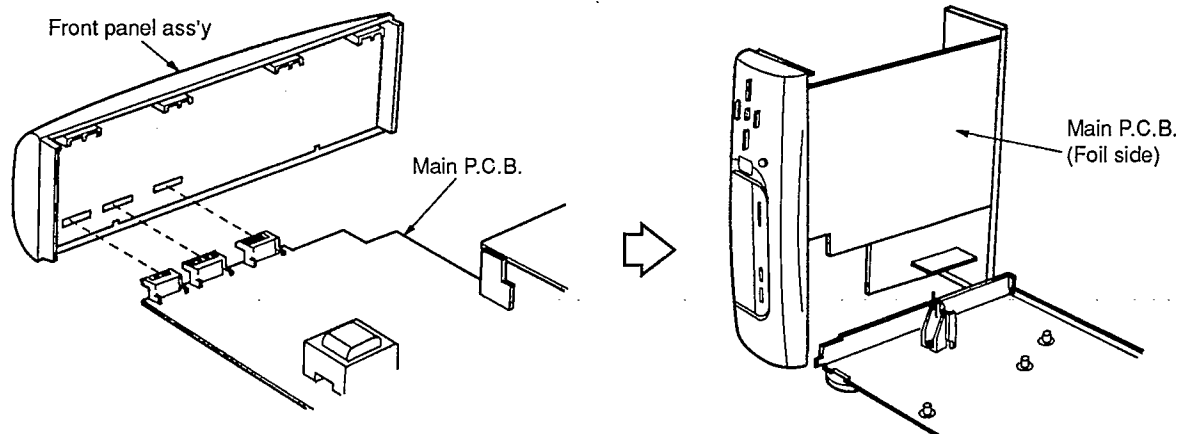

- Reinstall the front panel ass'y to the main P.C.B.

- Check the main P.C.B. (foil side) as shown above.

**Replacement of the Foot.**

- Remove the 4 heat melted posts on the bottom board ass'y with a pair of nippers or similar tool.
- To replace the foot (RKA0011A-2) on the bottom board ass'y, melt the 4 posts with a soldering iron.

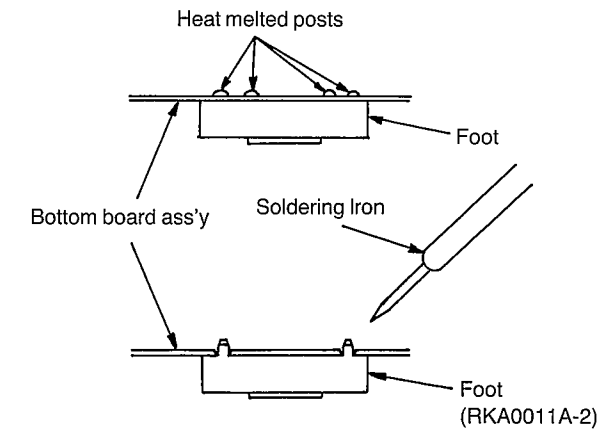

**Power Supply with Tuner ST-CH505**
**Power Supply to Main PCB**

- Apply 11 V AC power between C901 and C902 using the service tool for AC power supply as shown below. (The unit comes to STAND BY Mode.)
- Short the point P-SW to the cathode side of diode D908 as shown below. FL display tube lights and the unit comes to power ON mode.

**Power Supply to Tuner PCB**

- Apply 15 V DC power to J912 and J911 using the service tool for DC power supply as shown below.

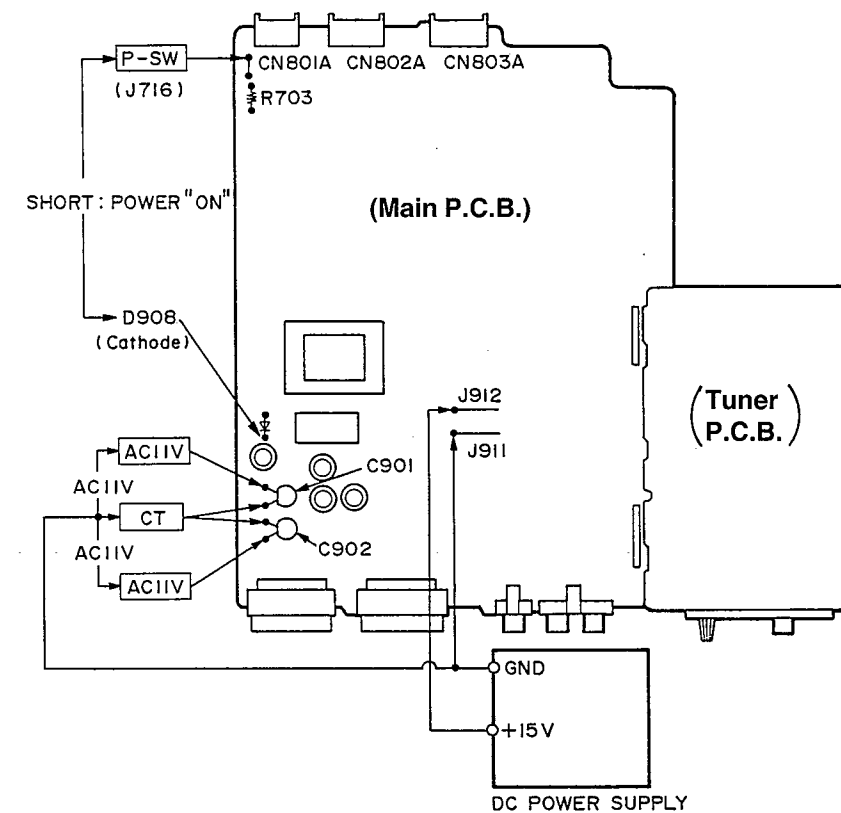
**Note:** When applying DC power, connect between GND and CT using the tool.



# Schematic Diagram • Tuner circuit (Parts list on pages 23~27)



• Indicated voltage values are the standard values for the unit measured by the DC electronic circuit tester (high-impedance) with the chassis taken as standard. Therefore, there may exist some errors in the voltage values, depending on the internal impedance of the DC circuit tester. No mark: FM mode ( ): MW mode < : LW mode

## A TUNER CIRCUIT

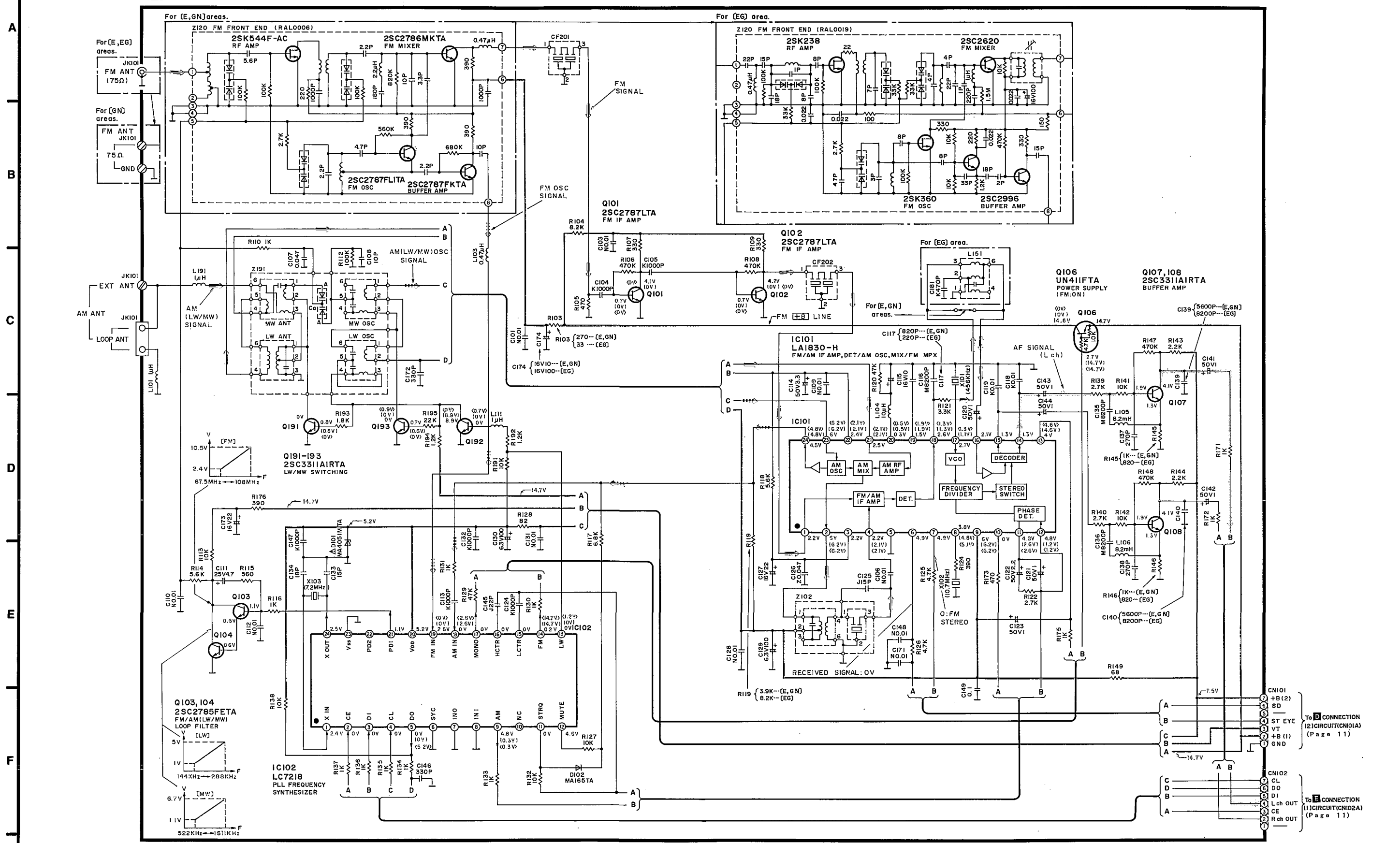

Schematic Diagram • Operation circuit (Parts list on pages 23~27)

B OPERATION CIRCUIT

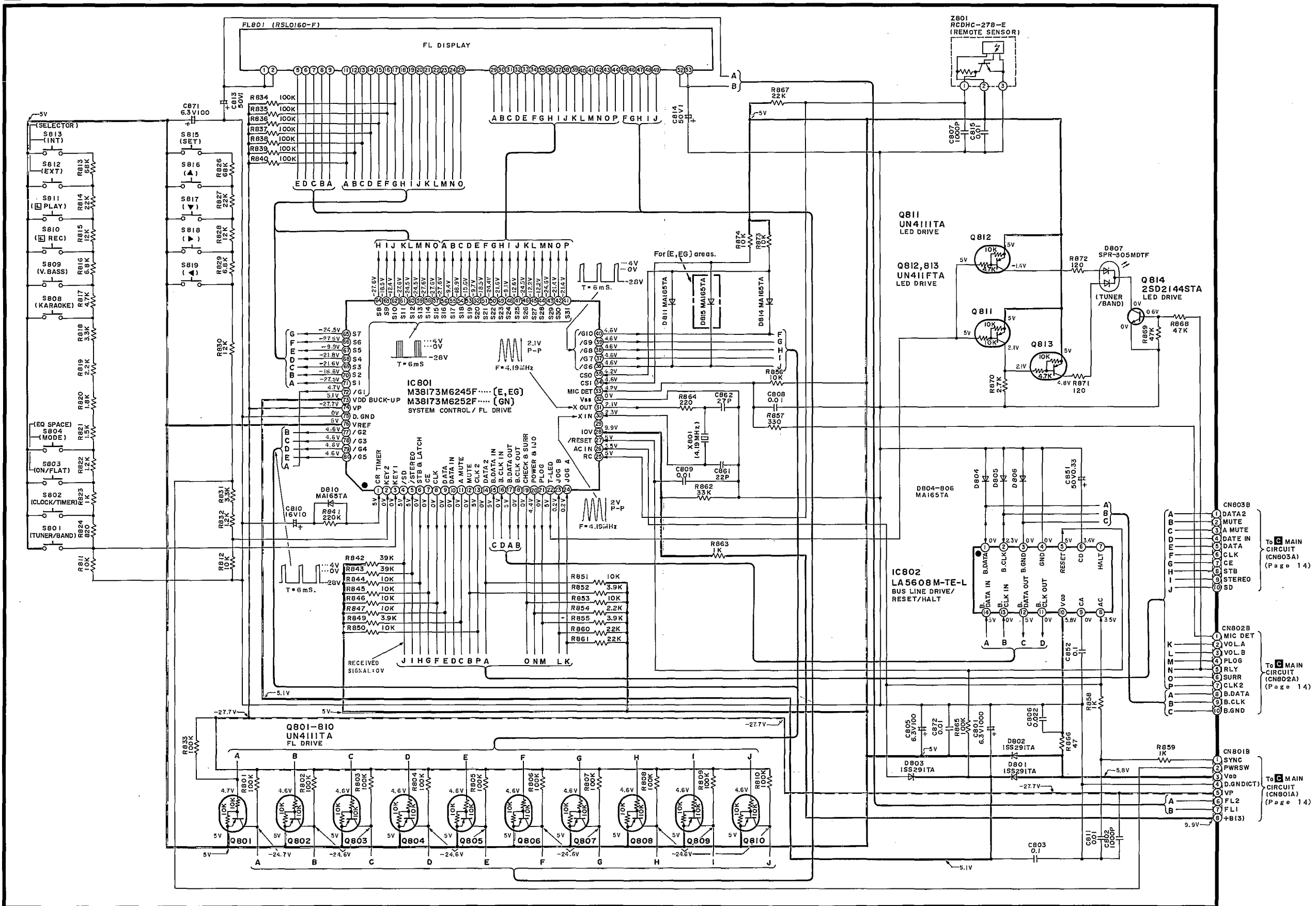

Schematic Diagram • Main, Connection (1)/(2) circuit (Parts list on pages 23-27)

Legend for signal lines: Positive voltage line, Negative voltage line, REC. OUT signal line, MIC signal line, AF signal line.

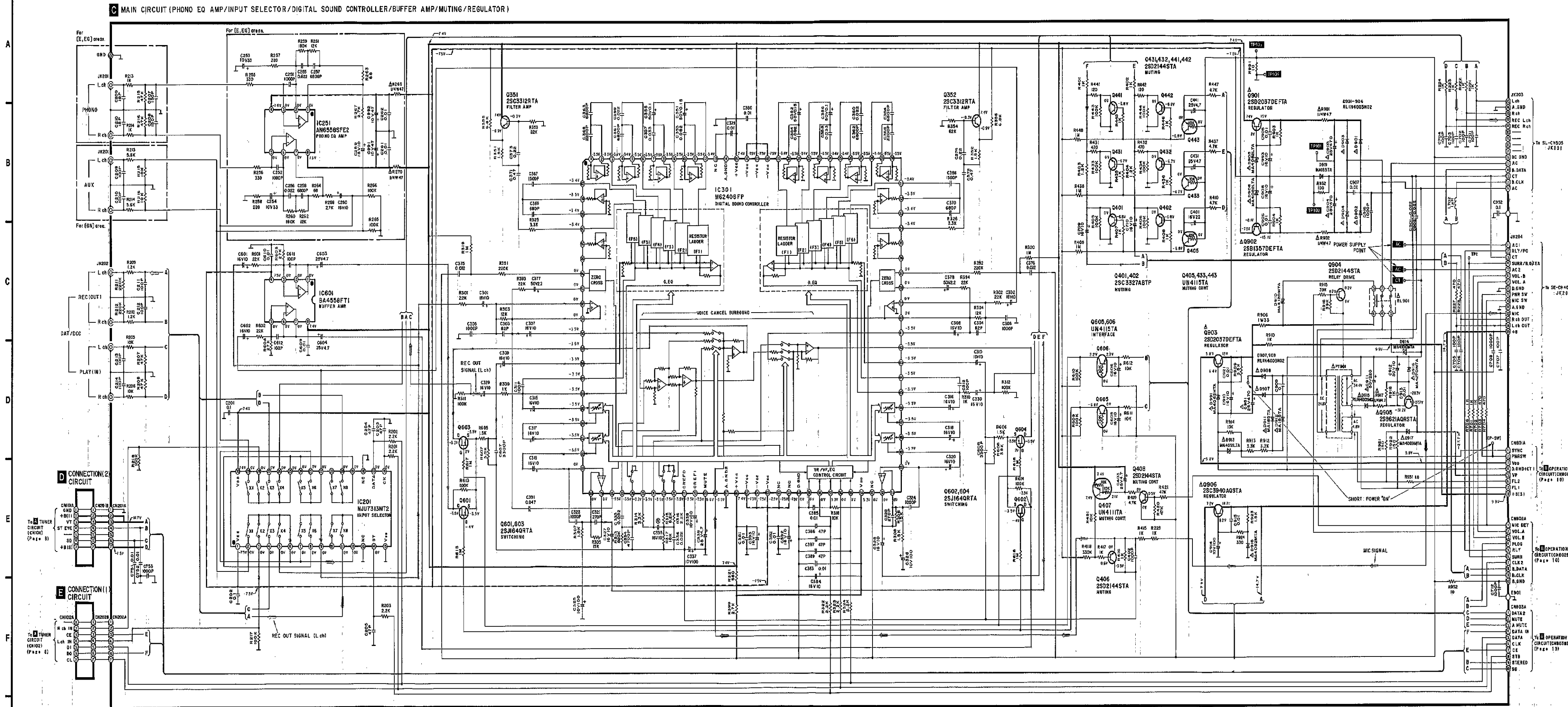

- Notes: S801 Tuner source/band select switch (TUNER/BAND), S802 Clock/timer switch (CLOCK/TIMER), S803 EQ/SPACE mode ON/FLAT switch (ON/FLAT), S804 EQ/SPACE mode select switch (MODE), S808 Voice mute switch (KARAOKE), S809 V. bass switch (V.BASS), S810 Record timer switch (IS REC), S811 Play timer switch (IS PLAY), S812 External source input select switch (EXT), S813 Internal source input select switch (INT), S815 Multi-control switch (SET), S816 Multi-control switch (▲), S817 Multi-control switch (▼), S818 Multi-control switch (▶), S819 Multi-control switch (◀)

Indicated voltage values are the standard values for the unit measured by the DC electronic circuit tester (high impedance) with the chassis taken as standard.

No mark: FM mode ( ); MW mode < >: LW mode

Important safety notices: Components identified by Δ mark have special characteristics important for safety. Furthermore, special parts which have purposes of fire-retardant (resistors), high-quality sound (capacitors), low-noise (resistors), etc. are used.

Caution! IC and LSI are sensitive to static electricity. Secondary trouble can be prevented by taking care during repair. Cover the parts boxes made of plastics with aluminum foil. Ground the soldering iron. Put a conductive mat on the work table. Do not touch the legs of IC or LSI with the fingers directly.

This schematic diagram may be modified at time with the development of new technology.

The supply part number is described alone in the replacement parts list.

Table with 3 columns: Ref. No., Production Parts No., Supply Parts No. Rows include IC601 and Z801.

Printed Circuit Board Diagram (Parts list on pages 23-27)

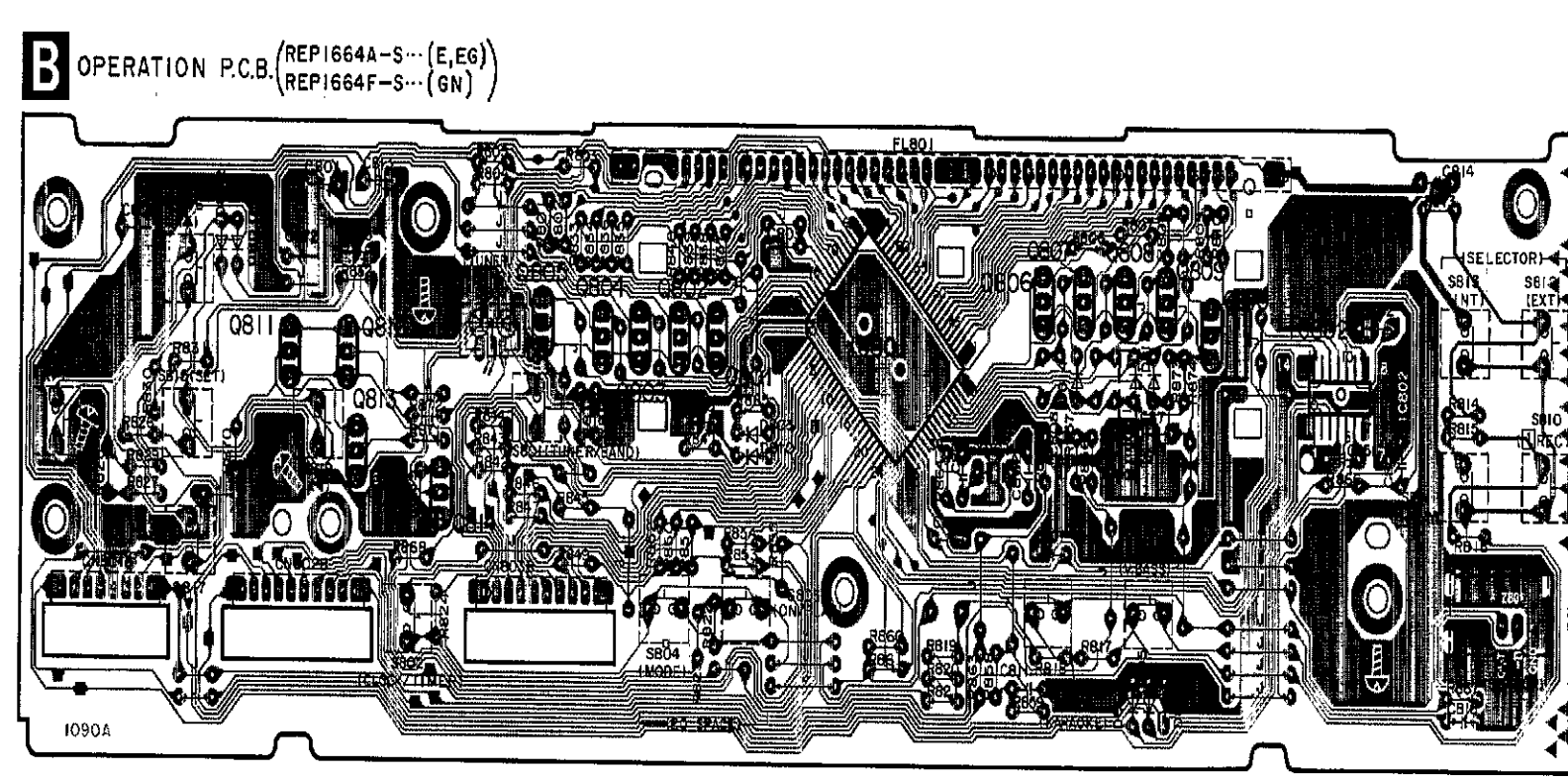
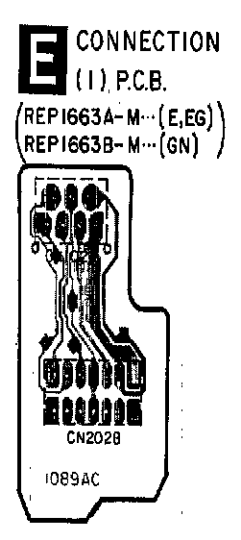
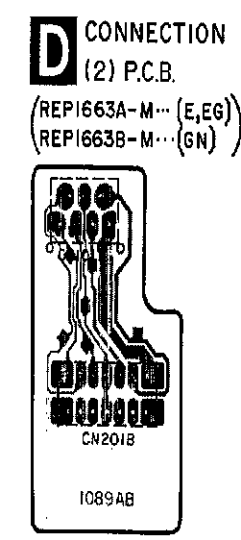
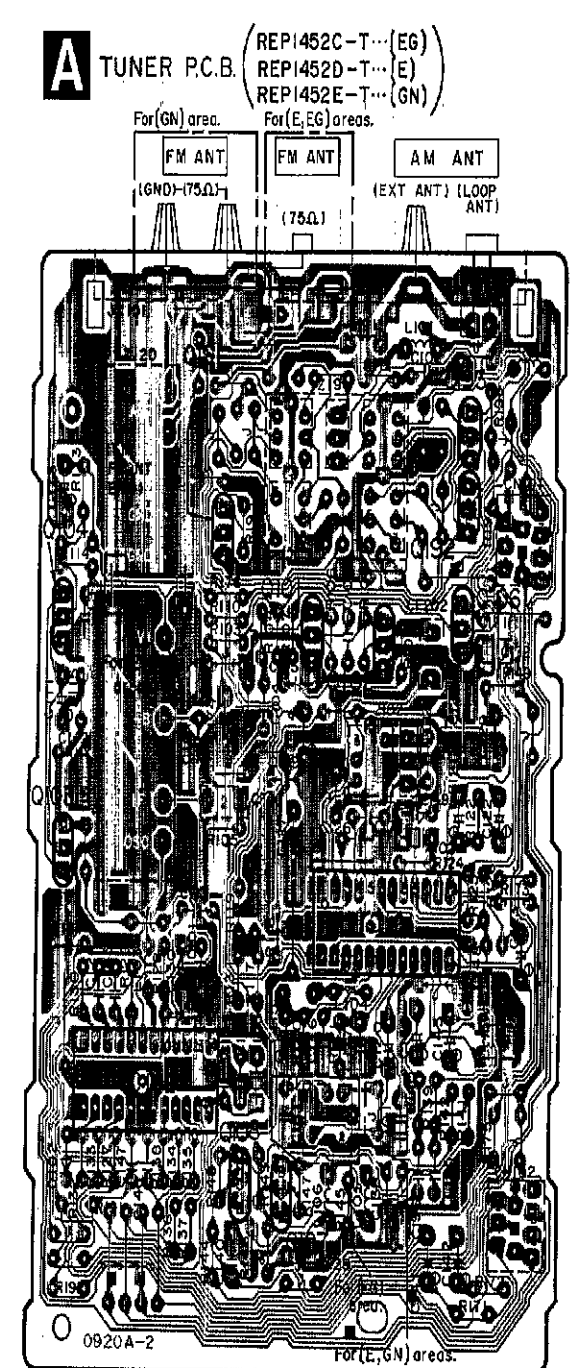
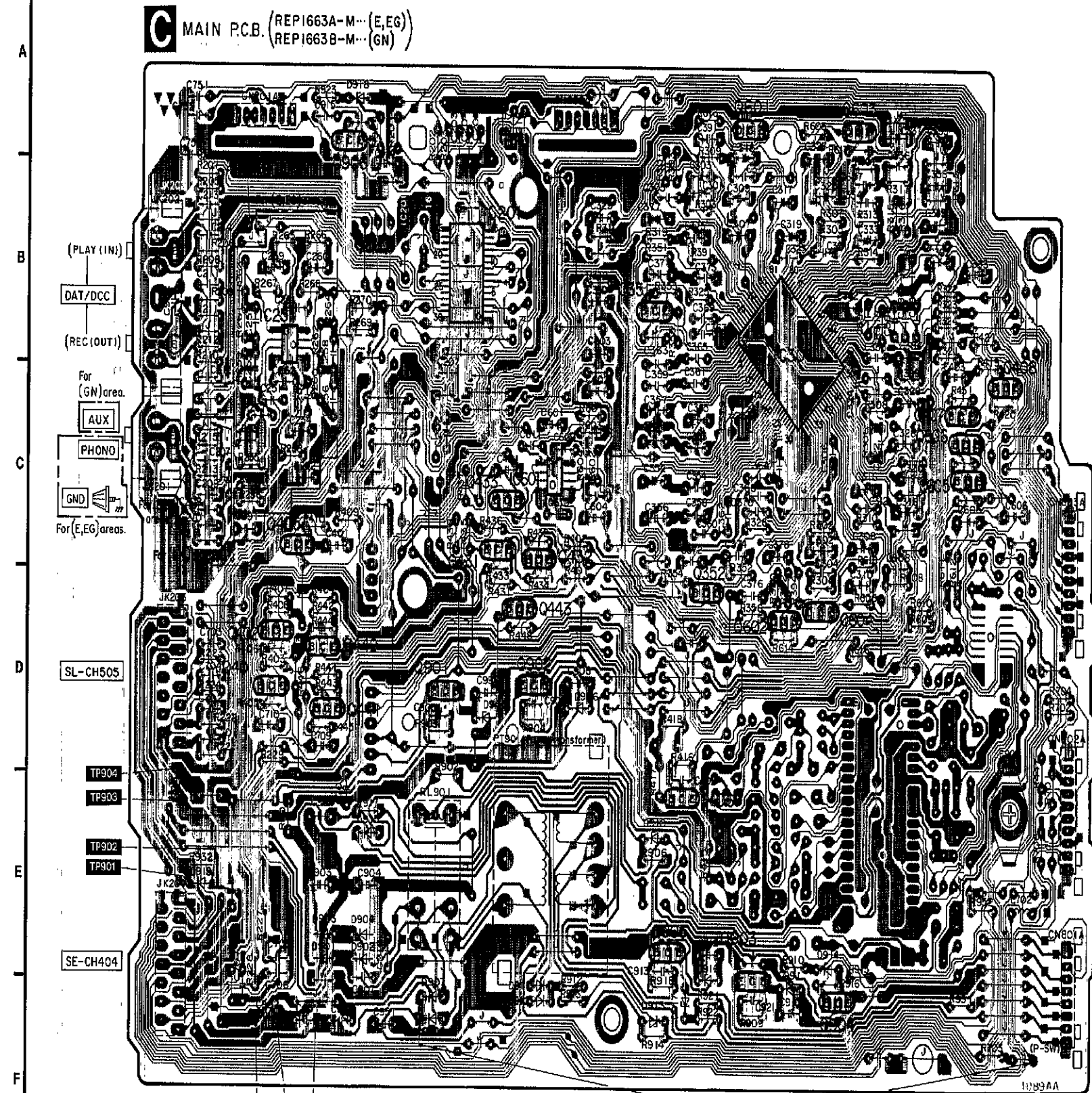
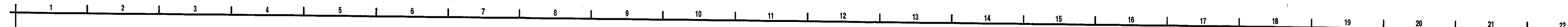

Terminal guide of IC's, transistors and diodes

BA4558FT1	AN6558SFE2 LA5608M-TE-L NJU7313MT2	8Pin 14Pin 30Pin	M38173M6245F M62408FP	80Pin 100Pin	LA1830-H LC7218	2SC2785FETA 2SC2787LTA 2SC3311A1RTA 2SC3312RTA UN4111FTA UN4111TA UN4115TA
2SB621ACRSTA	2SC3327ABTP	2SC3940AQSTA	2SD2144STA	2SB1357DEFTA 2SD2037DEFTA	2SJ164QRTA	MA165TA MA185TA 1S8291TA
MA4039MTA MA4051LTA MA4051MTA MA4082HTA MA4082LTA MA4082MTA	MA4100MTA MA4120MTA MA4270MTA	RL1N4003N02	SPR-305MDTF			

Wiring Connection Diagram

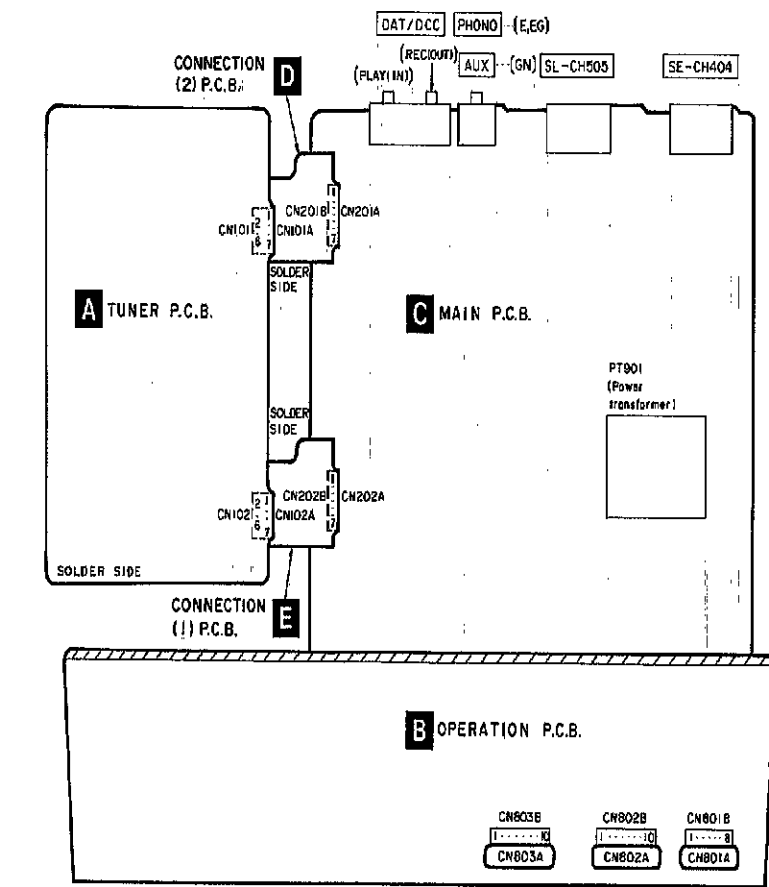

Note:  
This printed circuit board diagram may be modified at any time with the development of new technology.



Block Diagram

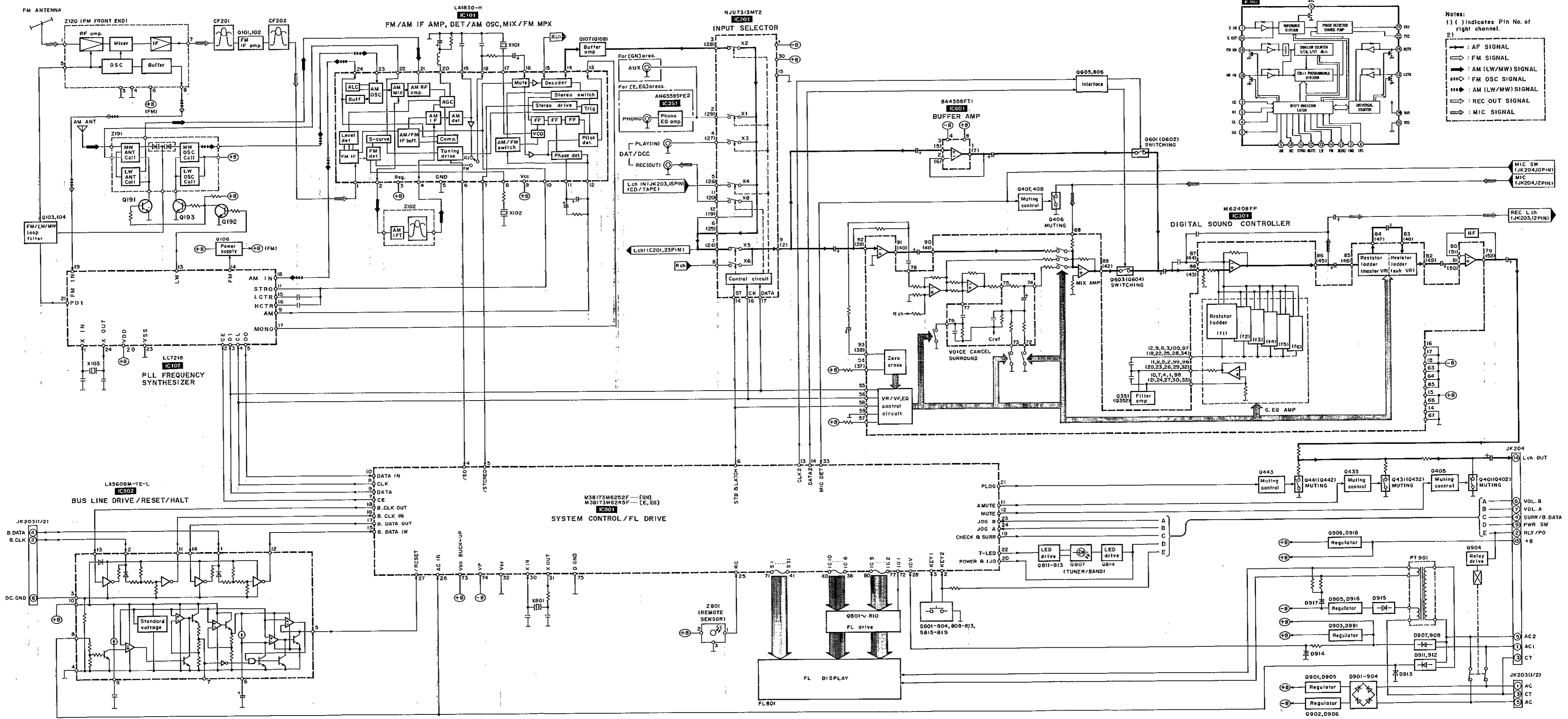

Notes:  
 1) ( ) Indicates Pin No. of right channel.  
 2)   
 → : AF SIGNAL  
 ⇨ : FM SIGNAL  
 ⇨⇨ : AM (LW/MW) SIGNAL  
 ⇨⇨⇨ : FM OSC SIGNAL  
 ⇨⇨⇨⇨ : AM (LW/MW) SIGNAL  
 ⇨⇨⇨⇨⇨ : REC OUT SIGNAL  
 ⇨⇨⇨⇨⇨⇨ : MIC SIGNAL

### ■ Functions of IC Terminals

●IC801 (M38173M6245F) for (E) (EG) areas/(M38173M6252F) for (GN) area

Pin No.	Terminal Name	I/O	Function
1	CR TIMER	O	Condensator/resistance oscillation terminal for an electronic failure detection
2	KEY2	I	Operation (MULTI CONTROL) key signal input
3	KEY1	I	Operation key signal input
4	/SD	I	SD signal input for tuner
5	/STEREO	I	STEREO signal input for tuner
6	STB&LATCH	O	Latch signal output to M62408 (IC301) and strobe signal output to NJU7313 (IC201)
7	CE	O	Chip enable signal output to LC7218 (IC102)
8	CLK	O	Clock signal output to M62408 (IC301)/NJU7313 (IC201)/LC7218 (IC102)
9	DATA	O	Data signal output to M62408 (IC301)/NJU7313 (IC201)/LC7218 (IC102)
10	DATA IN	I	Data signal input from LC7218 (IC102)
11	A MUTE	O	Audio muting signal output (Volume of -10 dB and less: "H")
12	MUTE	O	Main muting signal output (Normally "L")
13	CLK2	O	Serial clock output for M62408 (IC301)
14	DATA2	O	Serial data output for M62408 (IC301)
15	B.DATA IN	I	Data input from bus
16	B.CLK IN	I	Clock input from bus
17	B.DATA OUT	O	Data output to bus (Normally "H")
18	B.CLK OUT	O	Clock output to bus (Normally "L")
19	CHECK & SURR	O	POWER ON mode: Output for SUR ON/OFF (During POWER ON: "H") POWER OFF mode: Demultiplier output for clock control
20	POWER & I/O	I/O	Power control output (During POWER ON: "H") Heat detection input (Unusual situation: "H")
21	PLOG	O	Audio muting 2 signal output (Volume of -70 dB and less: "H")
22	T-LED	O	Selector TUNER output (Output in level "H")
23	JOG B	I	Rotary encoder input for main volume
24	JOG A	I	

### ■ Replacement Parts List

Notes: \*Important safety notice:  
Components identified by Δ mark have special characteristics important for safety. Furthermore, special parts which have purposes of fire-retardant (resistors), high-quality sound (capacitors), low-noise (resistors), etc. are used. When replacing any of components, be sure to use only manufacturer's specified parts shown in the parts list. \*The parenthesized indications in the Remarks columns specify the areas. (Refer to the cover page for area.) Parts without these indications can be used for all areas. \*The "(SF)" mark denotes the standard part.

Ref. No.	Part No.	Part Name & Description	Remarks
		INTEGRATED CIRCUIT(S)	
IC101	LA1830-H	I. C. FM/AM IF AMP. /AM OSC	
IC102	LC7218	I. C. PLL FREQ SYNTHESIZER	
IC201	NJU7313M2	I. C. INPUT SELECTOR	
IC251	AN6558SFE2	I. C. PHONO EQ AMP	(E) (EG)
IC301	M62408FP	I. C. DIGITAL SOUND CONT.	
IC601	SV18A4558F	I. C. BUFFER AMP.	
IC801	M38173M6245F	I. C. SYSTEM CONT. /FL DRIVE	(E) (EG)
IC801	M38173M6252F	I. C. SYSTEM CONT. /FL DRIVE	(GN)
IC802	LA5608M-TE-L	I. C. BUS LINE/HALT/RESET	
		TRANSISTOR(S)	
Q101, 102	2SC2787L	TRANSISTOR	
Q103, 104	2SC2785FE	TRANSISTOR	
Q106	UN411FTA	TRANSISTOR	
Q107, 108	2SC3311A1RTA	TRANSISTOR	
Q191-193	2SC3312RTA	TRANSISTOR	
Q351, 352	2SC3312RTA	TRANSISTOR	
Q401, 402	2SC3327-A	TRANSISTOR	
Q405	UN4115	TRANSISTOR	
Q406	2SD2144S	TRANSISTOR	
Q407	UN4111	TRANSISTOR	
Q408	2SD2144S	TRANSISTOR	
Q431, 432	2SD2144S	TRANSISTOR	
Q433	UN4115	TRANSISTOR	
Q441, 442	2SD2144S	TRANSISTOR	
Q443	UN4115	TRANSISTOR	
Q601-604	2SJ164QRTA	TRANSISTOR	
Q605, 606	UN4115	TRANSISTOR	
Q801-811	UN4111	TRANSISTOR	
Q812, 813	UN411FTA	TRANSISTOR	
Q814	2SD2144S	TRANSISTOR	
Q901	2SD2037DEFTA	TRANSISTOR	Δ
Q902	2SB1357DEFTA	TRANSISTOR	Δ
Q903	2SD2037DEFTA	TRANSISTOR	Δ
Q904	2SD2144S	TRANSISTOR	
Q905	2SB621A-R	TRANSISTOR	Δ
Q906	2SC3940AQSTA	TRANSISTOR	Δ
		DIODE (S)	
D101	MA4051MTA	DIODE	Δ
D102	MA165	DIODE	
D801-803	1SS291TA	DIODE	
D804-806	MA165	DIODE	
D807	SPR-305MDTF	DIODE	
D810, 811	MA165	DIODE	
D814	MA165	DIODE	
D815	MA165	DIODE	(E) (EG)
D901-904	RL1M4003N02	DIODE	Δ
D905, 906	MA4082L7A	DIODE	Δ
D907, 908	RL1M4003N02	DIODE	Δ
D910	MA4120	DIODE	
D911, 912	MA185TA	DIODE	Δ
D913	MA4051-L	DIODE	Δ
D914	MA4100MTA	DIODE	
D915	RL1M4003N02	DIODE	Δ
D916	MA4270	DIODE	Δ
D917	MA4039MTA	DIODE	Δ
D918	MA4082MTA	DIODE	Δ
D919	MA165	DIODE	
D991	MA4062-H	DIODE	Δ
		COIL (S)	
L101	ELESN1ROMA	COIL	
L103	ELEXT1R47MA9	COIL	
L104	ELEXT100KA9	COIL	
L105, 106	RLQZB822KT-D	COIL	
L111	ELEXT1ROKA9	COIL	
L151	SLM1B10M-1M	COIL	(EG)
L191	ELESN1ROMA	COIL	
L702	ELEXT1ROKA9	COIL	
		FILTER (S)	
CF201, 202	RLFFETWDD01M	CERAMIC FILTER	(E) (GN)
CF201, 202	RLFFETNGD01L	CERAMIC FILTER	(EG)
		DISPLAY	
FL801	RS10180-F	FL DISPLAY	
		SWITCH (ES)	
S801	EVQ21405R	SW. TUNER/BAND	
S802	EVQ21405R	SW. CLOCK/TIMER	
S803	EVQ21405R	SW. ON/FLAT	
S804	EVQ21405R	SW. MODE	

Ref. No.	Part No.	Part Name & Description	Remarks
S808	EVQ21405R	SW. KARAOKE	
S809	EVQ21405R	SW. V. BASS	
S810	EVQ21405R	SW. TIMER REC	
S811	EVQ21405R	SW. TIMER PLAY	
S812	EVQ21405R	SW. SELECTOR (EXT)	
S813	EVQ21405R	SW. SELECTOR (INT)	
S815	EVQ21405R	SW. MULTI CONTROL (SET)	
S816	EVQ21405R	SW. MULTI CONTROL (UP)	
S817	EVQ21405R	SW. MULTI CONTROL (DOWN)	
S818	EVQ21405R	SW. MULTI CONTROL (RIGHT)	
S819	EVQ21405R	SW. MULTI CONTROL (LEFT)	
		CONNECTOR (S)	
CN101, 102	RJU063W07T	SOCKET (7P)	
CN101A	RJT063W07T	CONNECTOR (7P)	
CN102A	RJT063W07T	CONNECTOR (7P)	
CN201A	RJT057W07-1	CONNECTOR (7P)	
CN202A	RJT057W07-1	CONNECTOR (7P)	
CN801A	RJU003K008M1	SOCKET (8P)	
CN802A	RJU003K010M1	SOCKET (10P)	
CN803A	RJU003K010M1	SOCKET (10P)	
CN201B	RJU057W007	SOCKET (7P)	
CN202B	RJU057W007	SOCKET (7P)	
CN801B	RJT003K008-1	CONNECTOR (8P)	
CN802B	RJT003K010-1	CONNECTOR (10P)	
CN803B	RJT003K010-1	CONNECTOR (10P)	
		EARTH TERMINAL	
ES01	SNE1004-1	GND PLATE	
		TRANSFORMER	
PT901	RTP114G004	POWER TRANSFORMER	Δ
		RELAY	
RL901	RSY0017M-0	RELAY	Δ
		JACK (S)	
JK101	RJH202M	ANTENNA TERMINAL	(E) (EG)
JK101	RJH4405-1M	ANTENNA TERMINAL	(GN)
JK201	SJF3068R	PHONO (E) (EG)/AUX (GN)	
JK202	SJF3069-5R	DAT/DCC	
JK203	RJT065K15	CONNECTOR (15P) (BLACK TYPE)	
JK204	RJT065W15	CONNECTOR (15P) (WHITE TYPE)	
		COMPONENT COMBINATION (S)	
Z102	RL122006M-T	COMPONENT COMBINATION	



922

■ Cabinet Parts Location

Ref. No.	Part No.	Values & Remarks
C807	ECBT1H102KB5	50V 1000P
C808, 809	ECBT1E103ZF	25V 0.01U
C810	ECEA1CKA100B	16V 10U
C811	ECBT1E103ZF	25V 0.01U
C813, 814	ECEA1HKA010B	50V 1U
C815	ECBT1E103ZF	25V 0.01U
C851	ECEA1HKAR33B	50V 0.33U
C852	ECQV1H104JM3	50V 0.1U
C861	ECBT1H220JC5	50V 22P
C862	ECBT1H270JU5	50V 27P
C871	ECEA0JKA101B	6.3V 100U
C872	ECBT1E103ZF	25V 0.01U
C901, 902	ECKT1H223ZF	50V 0.022U
C903, 904	ECA1EM471B	25V 470U Δ
C905-907	ECBT1E103ZF	25V 0.01U
C908	ECEA1CKA100B	16V 10U
C909	ECBT1H104ZF5	50V 0.1U
C910	ECEA1CKA100B	16V 10U
C911	ECA1HM221B	50V 220U Δ
C912	ECEA1HKA100B	50V 10U
C913	ECBT1E103ZF	25V 0.01U
C914	ECEA1AKA101B	10V 100U
C915	ECBT1E103ZF	25V 0.01U
C916	ECBT1H102KB5	50V 1000P
C921	ECBT1E103ZF	25V 0.01U
C951	ECA1EM471B	25V 470U Δ
C952	ECBT1H104ZF5	50V 0.1U
C991, 992	ECEA1AKA470B	10V 47U (E) (EG)
C993	ECEA1CKA100B	16V 10U

Ref. No.	Part No.	Part Name & Description	Remarks
		CABINET PARTS	
1	RHD30007	SCREW	
2	RKM0203A-1K	CABINET	
3	XTB3+8JFZ	SCREW	
4	RGR0176A-A1	REAR PANEL	(E)
4	RGR0176A-G	REAR PANEL	(EG)
4	RGR0176A-D1	REAR PANEL	(GN)
5	RFKJSC404EK	BOTTOM BOARD ASS'Y	
5-1	RKA0011A-2	FOOT	
6	RMN0231	HOLDER	
7	RMN0195-3	FL SPACER	
8	RMN0230	FL HOLDER	
9	RFKGTCH505EK	FRONT PANEL ASS'Y	
9-1	RKW0297-V	FL PANEL	
10	RGL0218-Q	PANEL LIGHT	
11	RGU0959-K	BUTTON, MULTI CONTROL etc.	
12	RGU0960-K	BUTTON, EQ SPACE etc.	
13	XTBS26+8J	SCREW	
14	SHE185-2	P. C. B. SPACER	
15	SNE2123	GND SCREW	(E) (EG)
16	XTBS3+8JFZ1	SCREW	
17	XTB3+16JFZ	SCREW	
18	RMC0229	SHIELD PLATE	(EG)

