

Service Manual

Tuner/Sound Processor

Tuner

ST-CH540

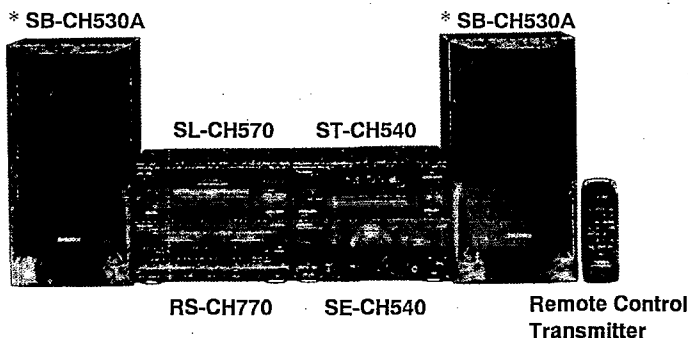

Colour

(K) : Black

Areas

Suffix for Model No.	Area	Colour
(E)	Europe	(K)
(EG)	Germany	

System: SC-CH540

Because of unique interconnecting cables, when a component requires service, send or bring in the entire system.

Specifications

■ Pre-amplifier section

Input sensitivity/impedance

PHONO	2.5 mV/47 k Ω
EXTERNAL	250 mV/15 k Ω

Output level

EXTERNAL REC OUT	150 mV/1.5 k Ω
------------------	-----------------------

Frequency response

PHONO	30 Hz – 15 Hz/+1.5 to -2.0 dB
EXTERNAL	20 Hz – 40 kHz

S/N

PHONO	DIN 73 dB (77 dB, IHF)
EXTERNAL	DIN 80 dB, (82 dB, IHF)

■ EQ/SFP section

Center frequency 120 Hz, 1 kHz, 7 kHz

EQ SPACE mode

3 modes	HALL, CLEAR, HEAVY
---------	--------------------

V. BASS mode

Center frequency	70 Hz
V. BASS 1	+3 dB
V. BASS 2	+6 dB

■ FM tuner section

Frequency range 87.50 – 108.00 MHz (0.05 MHz steps)

Sensitivity 1.8 μ V (IHF usable)

S/N 26 dB	1.5 μ V
-----------	-------------

S/N MONO 70 dB (75 dB, IHF)

Stereo separation 1kHz 35 dB

Antenna terminal(s) 75 Ω (unbalanced)

■ AM tuner section

Frequency range

[For (E) area]

MW	522 – 1611 kHz (9 kHz steps)
LW	530 – 1620 kHz (10 kHz steps)

[For (EG) area]

LW	144 – 288 kHz (9 kHz steps)
AM	522 – 1611 kHz (9 kHz steps)

530 – 1620 kHz (10 kHz steps)

Sensitivity (S/N 20 dB)

[For (E) area]

MW	500 μ V/m
LW	50 μ V

[For (EG) area]

AM	500 μ V/m
----	---------------

■ Timer section

Clock

Quartz-lock type

Function

24-hour programmable;

Play timer (1 time), REC timer (1 time),

Sleep (120 min, 30 min intervals)

1 minute-23 hours 59 minutes

(1 min intervals)

Setting

■ General

Dimensions (W x H x D)

270 x 89 x 282 mm

Weight

1.6 kg

Note: Specifications are subject to change without notice.

Weight and dimensions are approximate.

System	Tuner/sound processor	Compact disc player	Amplifier	Cassette deck	Speakers
SC-CH540	ST-CH540	SL-CH570	SE-CH540	RS-CH770	* SB-CH530A

*: Made in PAES

⚠ WARNING

This service information is designed for experienced repair technicians only and is not designed for use by the general public. It does not contain warnings or cautions to advise non-technical individuals of potential dangers in attempting to service a product.

Products powered by electricity should be serviced or repaired only by experienced professional technicians. Any attempt to service or repair the product or products dealt with in this service information by anyone else could result in serious injury or death.

Technics®

© 1996 Matsushita Electric Industrial Co., Ltd.
All rights reserved. Unauthorized copying
and distribution is a violation of law.

Contents

	Page		Page
Location of Controls	2	Printed Circuit Board Diagram	18~21
Setting the Time	2	Wiring Connection Diagram	21
About the Self-Diagnostic Mode	3	Block Diagram	22~25
Operation Check and Main Component Replacement Procedures	4	Function of IC Terminals	26
To Supply Power Source	5	Replacement Parts List	27~31
Schematic Diagram	6~17	Cabinet Parts Location	32

NOTE:

Refer to the service manual for Model No. SE-CH540 (ORDER No. AD9604092C2) for information on "Accessories", "Stacking the Components", "Connections" and "Packaging".

Location of Controls

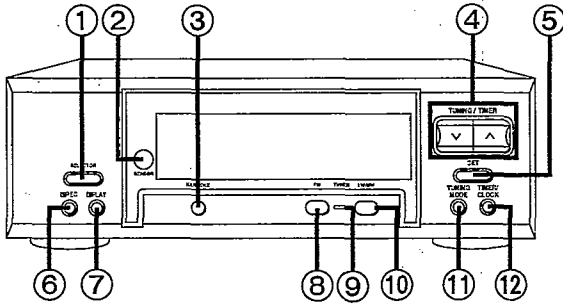

- ① Source input select button (SELECTOR)
- ② Remote control signal sensor (SENSOR)
- ③ Karaoke button ((KARAOKE)
- ④ Tuning/timer select button (TUNING/TIMER, Δ , ∇)
- ⑤ Set button (SET)
- ⑥ Record timer button (\ominus REC)
- ⑦ Play timer button (\ominus PLAY)
- ⑧ FM mode select button (FM, -AUTO/MONO)
- ⑨ Tuner indicator (TUNER)
- ⑩ LW/MW select button (LW/MW) for (E) area
AM button (AM) for (EG) area
- ⑪ Tuning mode select button (TUNING MODE)
- ⑫ Clock/timer button (CLOCK/TIMER)

Setting the Time

This is a 24-hours display clock.
These instructions explain how to set the timer for 16:25 (4:25 p.m.) on Wednesday.

- 1 Switch on the power.
- 2 ① Press CLOCK/TIMER to show "CLOCK".
Within 8 seconds:
② Press SET.
- 3 ① Press TUNING/TIMER (∇ or Δ) to select the day.
② Press SET.
- 4 ① Press TUNING/TIMER (∇ or Δ) to select the hour.
② Press SET.
- 5 ① Press TUNING/TIMER (∇ or Δ) to select the minutes.
② Press SET to finish setting the time.
The display will return to the previous display after about 3 seconds.

When "SUN 0:00" flashes:

It flashes when you connect the AC power supply cord for the first time or if there has been a power failure.
If this happens, reset the time.

If the minutes setting has gone wrong:

1. Press CLOCK/TIMER.
2. Press SET 3 times.
3. Press TUNING/TIMER (∇ or Δ) to set the minute, and then press SET.

To display the clock again:

Press CLOCK/TIMER.
The clock display will appear for about 8 seconds.

For Your reference:

When you turn OFF the power from the POWER button, the stereo goes on standby and the STANDBY lamp lights up.

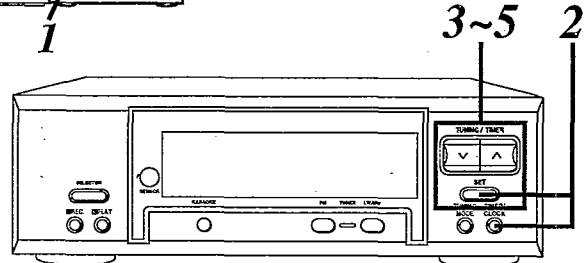
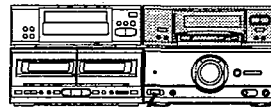

<p>1</p> <p>POWER</p> <p>STANDBY</p>	<p>2</p> <p>① TIMER/CLOCK ② SET</p> <p>CLOCK</p>	<p>3</p> <p>① TUNING/TIMER ② SET</p> <p>WED</p>
<p>4</p> <p>① TUNING/TIMER ② SET</p> <p>16</p>	<p>5</p> <p>① TUNING/TIMER ② SET</p> <p>25</p>	

■ About the Self-Diagnostic Mode

This unit is equipped with a self-diagnostic function which, in the event of a malfunction, automatically displays a code indicating the nature of the malfunction. Use this self-diagnostic function when servicing the unit.

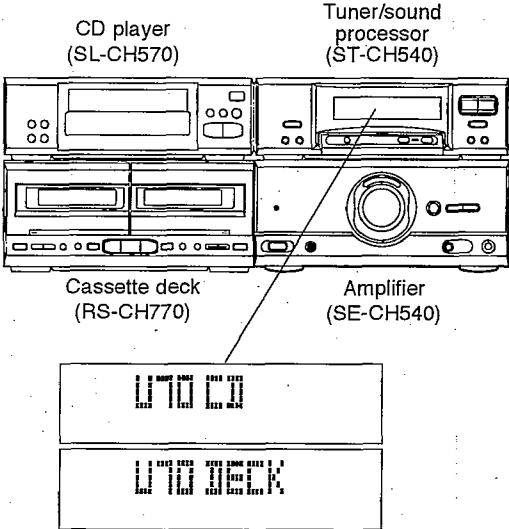
Display method	Display location
<p>To display the malfunction code</p> <p>U-70 CD: U-70 DECK: ... Automatically displays on the tuner/sound processor when a malfunction occurs.</p> <p>F-61 Automatically displays on the tuner/sound processor when a malfunction occurs.</p> <p>To return to the normal display</p> <p>1. For U-70 CD/U-70 DECK:</p> <ul style="list-style-type: none"> • Press an any operation button on the tuner/sound processor. • To re-display the code, switch the power off (POWER STANDBY button), and then switch power back on again. <p>2. For F-61:</p> <ul style="list-style-type: none"> • If "F-61" is displayed, the power will automatically be switched off and the standby indicator will light up. • "F-61" will be displayed for 3 seconds, and then the clock will be displayed. • To re-display the code, switch the power on. "F-61" will be re-displayed, and then after 3 seconds the clock will be displayed and the power will automatically switch off. 	

Display contents

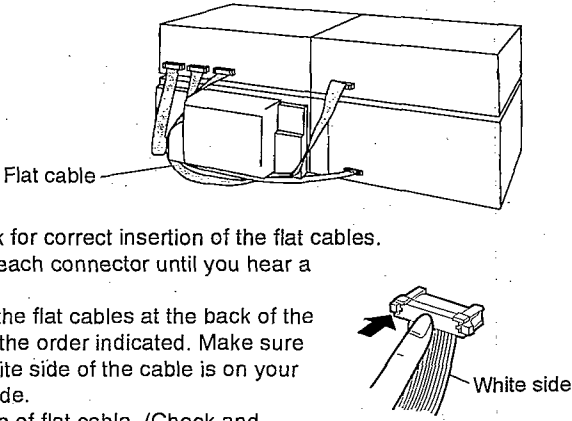
Display code	Problem or condition	Correction procedure
<p>U-70 CD U-70 DECK (displayed automatically)</p>	<p>A bus-line communications error has occurred as a result of the flat cables being inserted incorrectly, thus preventing the system from operating.</p> <p>1. If "U-70" is displayed on the tuner/sound processor, the tape deck or CD Changer cannot be operated by remote control.</p>	 <p>1. To check for correct insertion of the flat cables.</p> <ol style="list-style-type: none"> ① Insert each connector until you hear a click. ② Insert the flat cables at the back of the unit in the order indicated. Make sure the white side of the cable is on your right side. <p>2. Breakage of flat cable. (Check and replace as necessary.)</p> <p>3. If the problem is not corrected by items (1.) and (2.) above, this indicates a faulty IC.</p> <p>ST-CH540: IC901 (M38197MA132F)</p> <p>SL-CH570: IC403 (LC66356B4G98)</p> <p>RS-CH770: IC701 (M37471M4650F)</p> <p>Check these IC's and replace as necessary.</p>
<p>F-61</p>	<p>When the power switch is switched on, it automatically switches back off, making it impossible to switch power on.</p>	<ul style="list-style-type: none"> • Faulty amplifier (SE-CH540) output IC (IC501). (When a DC voltage is applied to the speaker terminals.)

Operation Check and Main Component Replacement Procedures

- NOTE**
1. This section describes procedures for checking the operation of the major printed circuit boards and replacing the main components.
 2. For reassembly after operation checks or replacement, reverse the respective procedures. Special reassembly procedures are described only when required.
 3. Illustrated screws are equivalent to actual size.

1. Checking for the tuner P.C.B. and operation P.C.B.

• Check the tuner P.C.B. and operation P.C.B. as shown below.

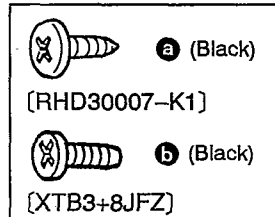
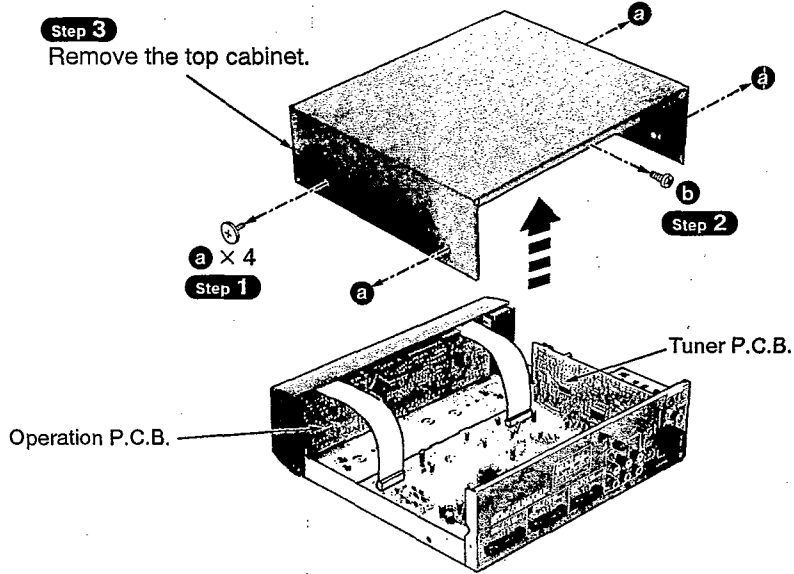

2. Checking for the main P.C.B.

• Check the main P.C.B. as shown below.

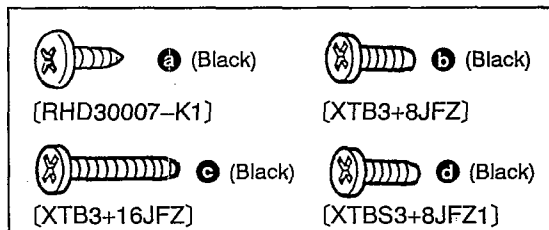
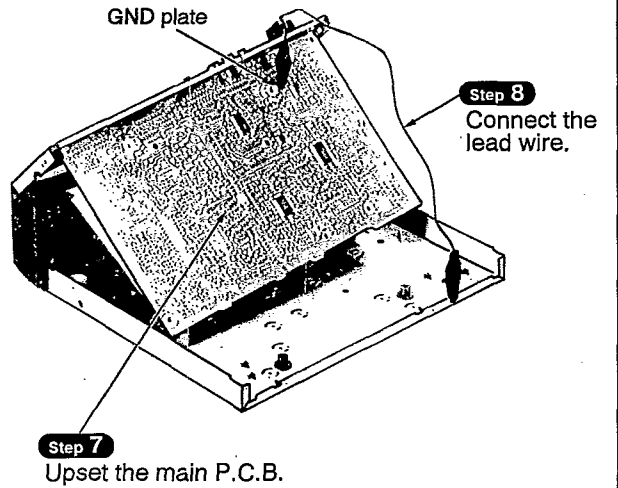
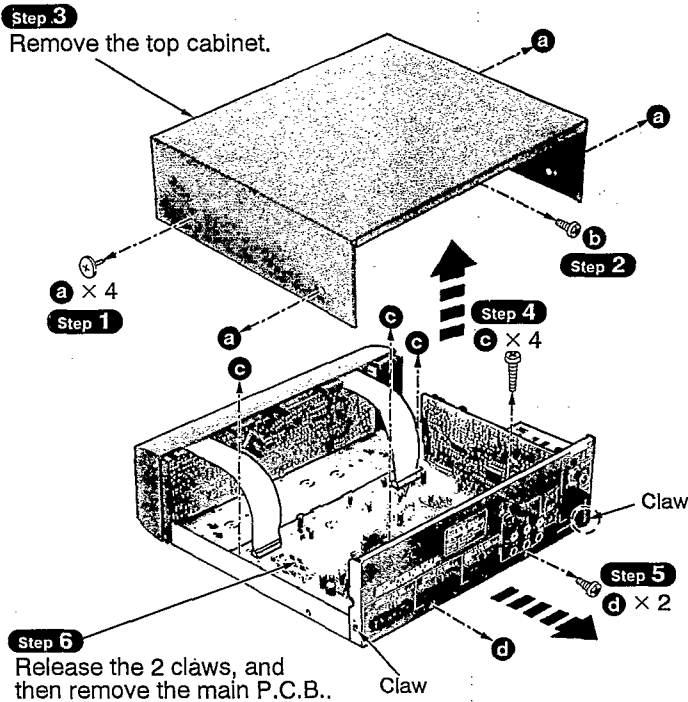

■ To Supply Power Source

This unit ST-CH540 is designed to operate on power supplied from the Amplifier SE-CH540.

When operating the unit ST-CH540 alone for testing and servicing, without having power supplied from the Amplifier SE-CH540, use the following method.

Power Supply to Main Circuit

1. Short the section between the test points **TP602** and **TP610**, and as well as the section between the test points **A.GND** (J611) and **TP610**.
2. Connect the 3V AC power to pin 1 of the indicator module FL901 and the GND terminal to pin 57 of the same FL901 module.
3. Apply 11 V AC power to the section between the point **TP601** (AC) and the point **TP602** (CT) as well as the section between the point **TP603** (AC) and the point **TP602** (CT). This unit comes to stand-by mode.
4. Short the section between the jumper **J315** **TP611** and the point **D.GND** of the jumper **J608** **TP610** for a moment. The main circuit comes to power ON mode. (Whenever this operation is performed, power, ON/OFF mode is repeated.)

Power Supply to Tuner Circuit

1. Apply power source to the main circuit.
2. Connect the DC +12 V terminal to the jumper **J610** **TP608**, and the GND terminal to both the point **T.GND** of the jumper **J609** **TP609** and the point **D.GND** of the jumper **J608** **TP610** using the DC power supply tool.

Note: If the GND terminal of the DC power supply tool is connected to the point **D.GND** of the jumper **J608** **TP610**, an error occurs in measurement values for voltage and waveform..

To Check Signals

Connect the oscilloscope or the speaker with the built-in amplifier to the EXTERNAL (OUT) terminals and check if the signals are outputting from this unit.

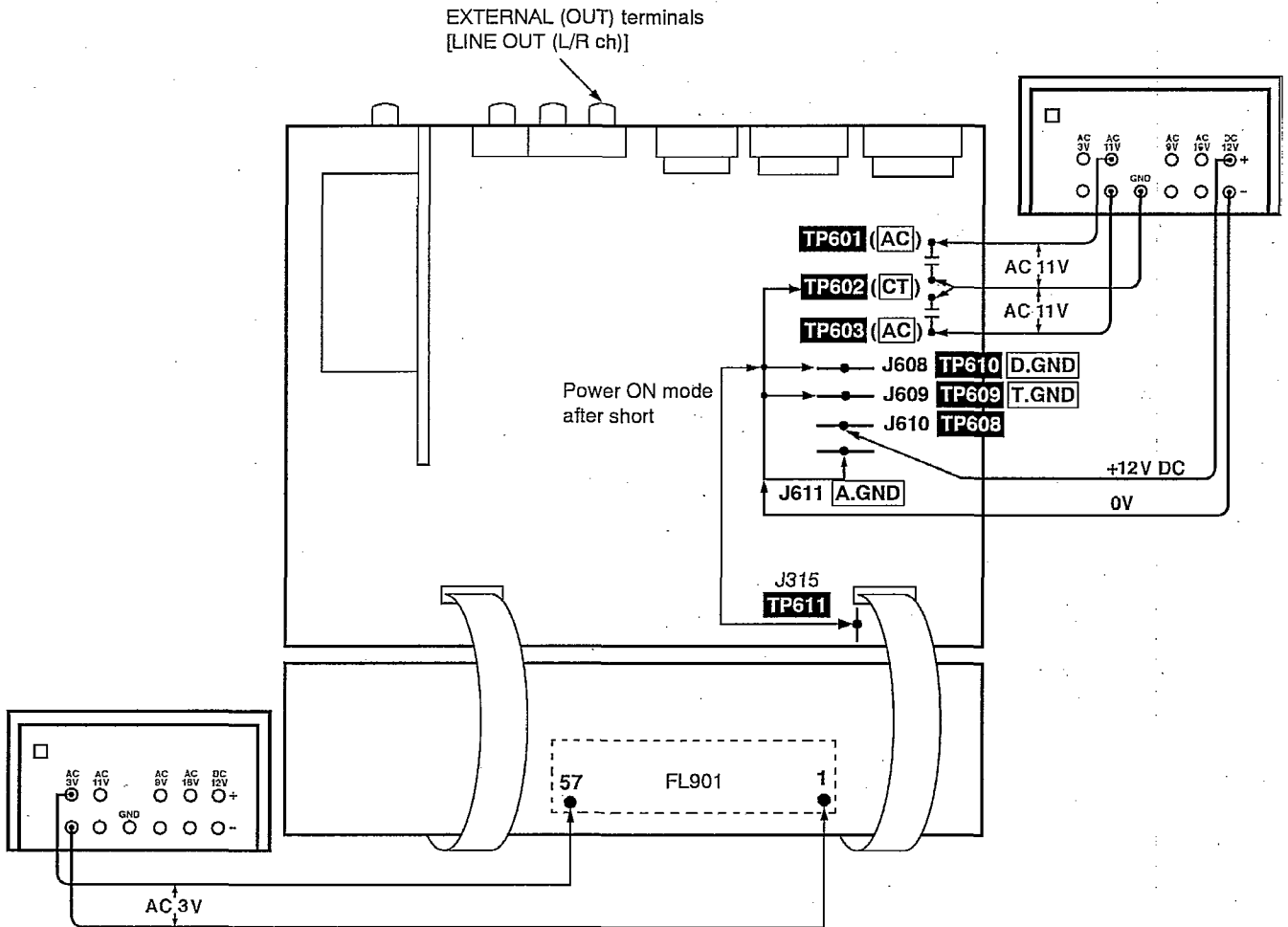

Fig. 1

Schematic Diagram

	Page
C MAIN CIRCUIT	7 ~ 11
A TUNER CIRCUIT For (E) area	12, 13
A TUNER CIRCUIT For (EG) area	14, 15
B OPERATION CIRCUIT	16, 17

• This schematic diagram may be modified at any time with the development of new technology.

Notes:

- **S901**: FM mode select switch (FM, -AUTO/MONO)
- **S902**: LW/MW select switch (LW/MW) for (E) area
AM switch (AM) for (EG) area
- **S903**: Tuning mode select switch (TUNING MODE)
- **S904**: Clock/timer switch (CLOCK/TIMER)
- **S905**: Set switch (SET)
- **S906**: Tuning/timer select switch (TUNING/TIMER ∨)
- **S907**: Tuning/timer select switch (TUNING/ TIMER ∧)
- **S915**: Karaoke switch (KARAOKE)
- **S916**: Play timer switch (⊕ PLAY)
- **S917**: Record timer switch (⊕ REC)
- **S918**: Source input select switch (SELECTOR)
- Indicated voltage values are the standard values for the unit measured by the DC electronic circuit tester (high-impedance) with the chassis taken as standard. Therefore, there may exist some errors in the voltage values, depending on the internal impedance of the DC circuit tester.
- Voltage values and waveforms are measured as indicated in the schematic diagram when test points between **TP602** and **TP610**, and between **TP610** and **A.GND** are shorted.

No mark : FM mode () : AM (MW) mode < > : AM (LW) mode

• **Important safety notice:**

Components identified by **△** mark have special characteristics important for safety. Furthermore, special parts which have purposes of fire-retardant (resistors), high-quality sound (capacitors), low-noise (resistors), etc. are used. When replacing any of components, be sure to use only manufacturer's specified parts shown in the parts list.

• **Caution!**

IC and LSI are sensitive to static electricity.
Secondary trouble can be prevented by taking care during repair.
Cover the parts boxes made of plastics with aluminum foil.
Ground the soldering iron.
Put a conductive mat on the work table.
Do not touch the legs of IC or LSI with the fingers directly.

• **Voltage and signal line**

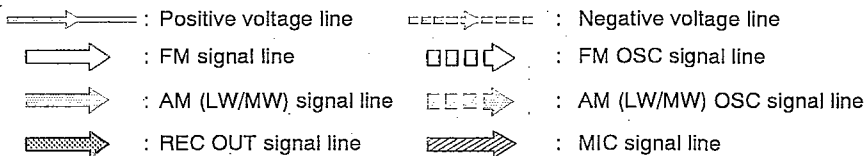

C MAIN CIRCUIT (P.C.Board: on page 19)

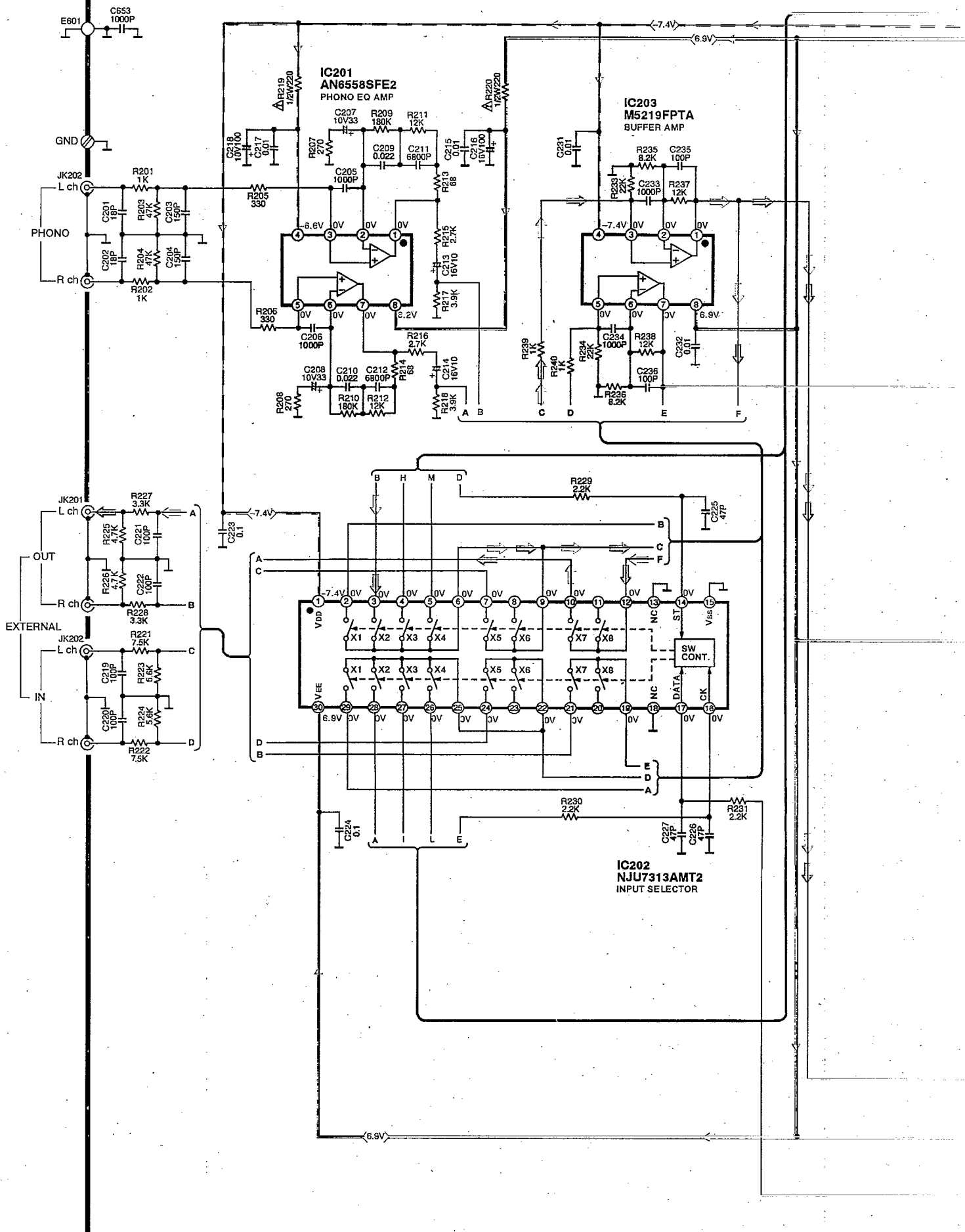

C MAIN CIRCUIT (P.C.Board: on page 19)

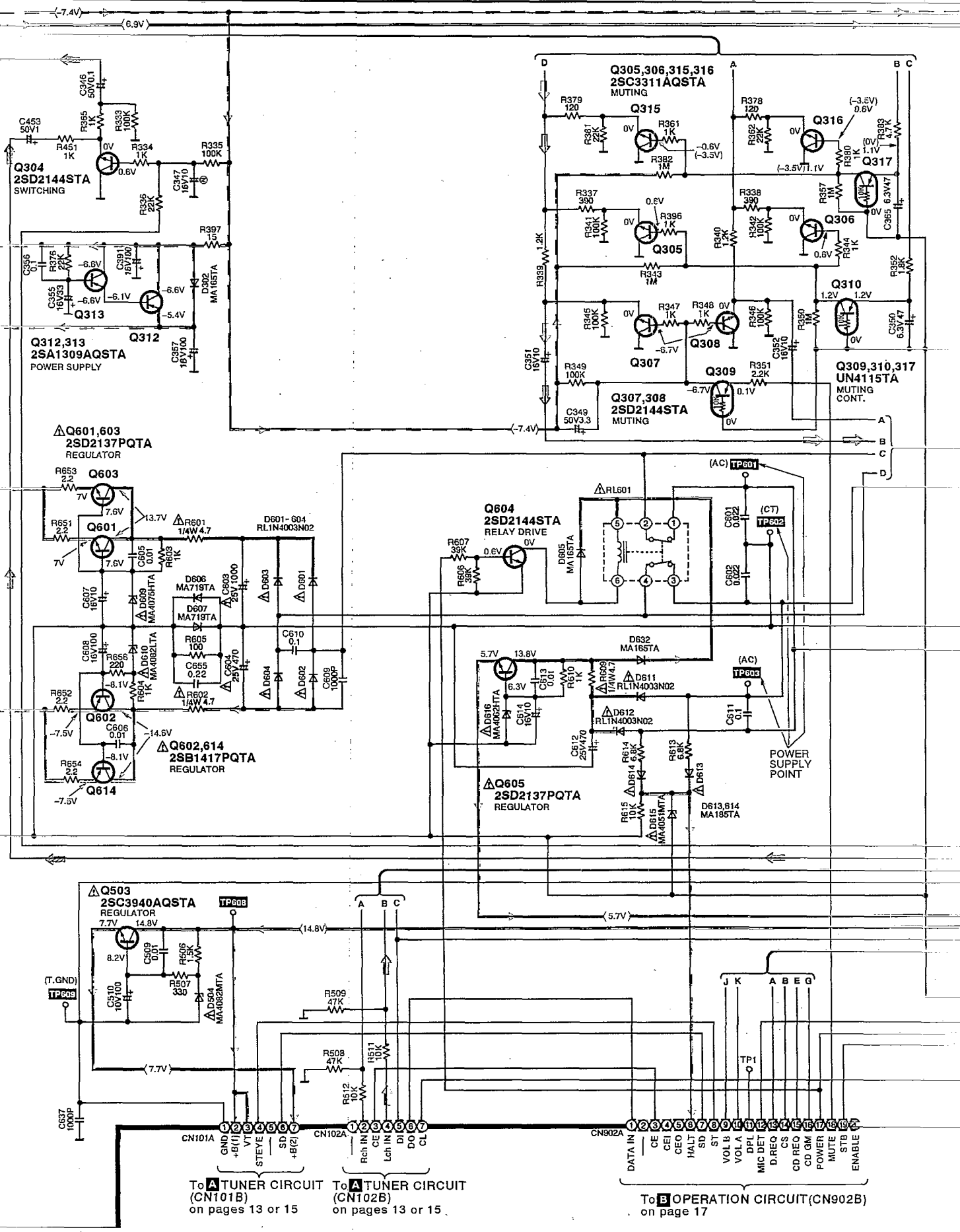

To **A** TUNER CIRCUIT (CN101B) on pages 13 or 15

To **A** TUNER CIRCUIT (CN102B) on pages 13 or 15

To **E** OPERATION CIRCUIT (CN902B) on page 17

: Positive voltage line
 : Negative voltage line
 : FM signal line
 : AM signal line
 : REC OUT signal line
 : MIC signal line

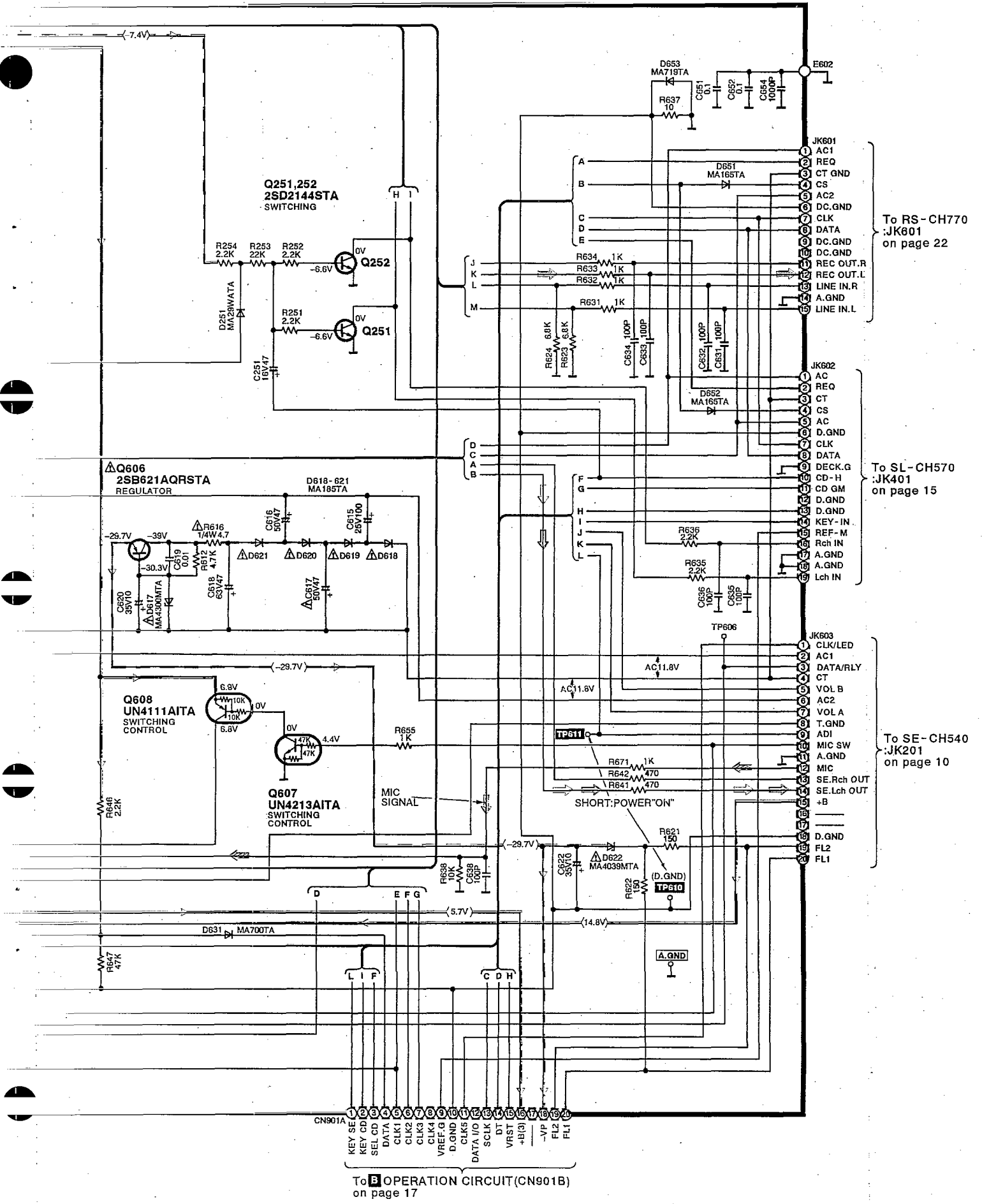

To RS-CH770
:JK601
on page 22

To SL-CH570
:JK401
on page 15

To SE-CH540
:JK201
on page 10

To OPERATION CIRCUIT(CN901B)
on page 17

A TUNER CIRCUIT For [E] area. (P.C. Board: on page 18)

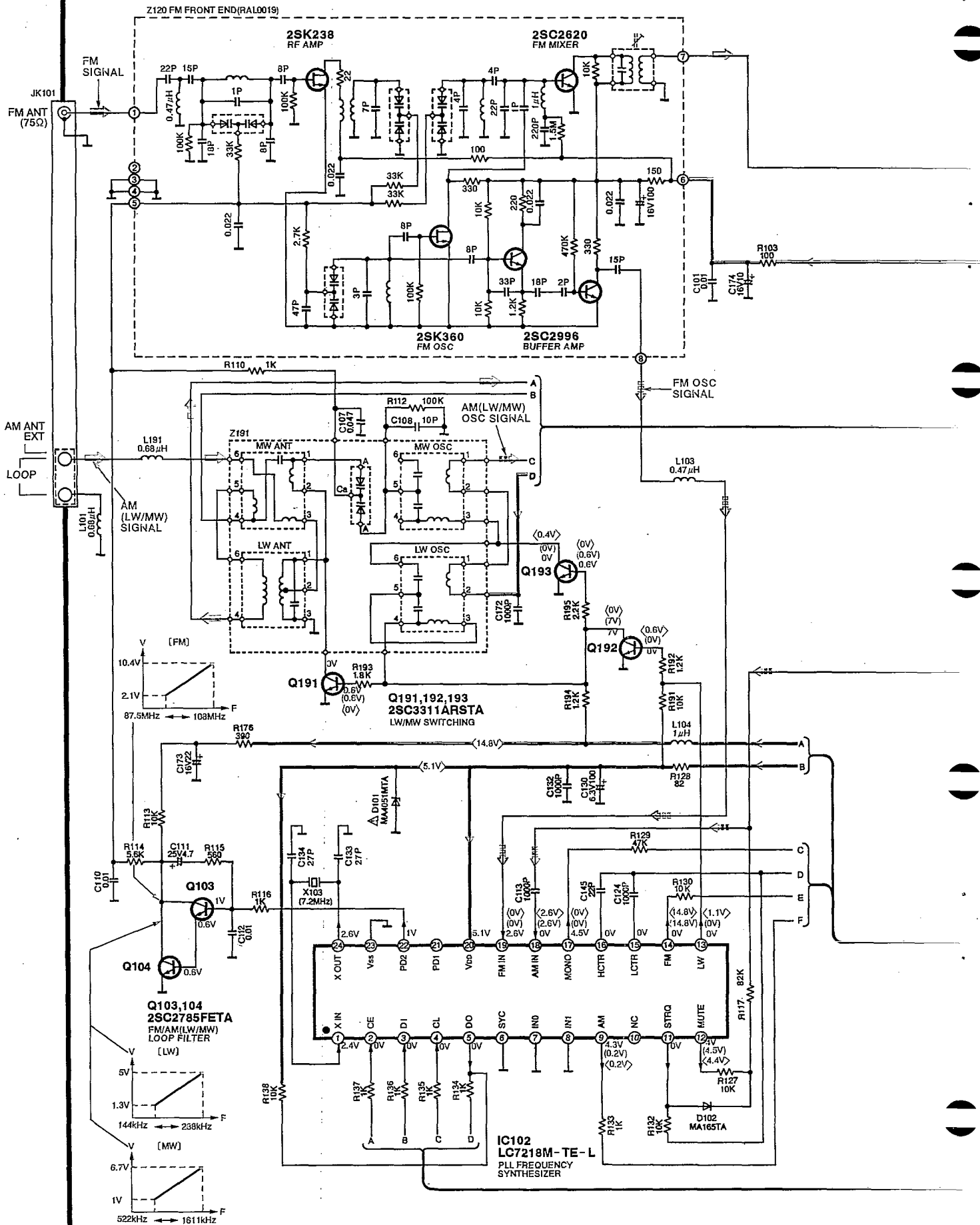

: Positive voltage line
 : FM signal line
 : FM OSC signal line
 : AM (LW/MW) signal line
 : AM (LW/MW) OSC signal line

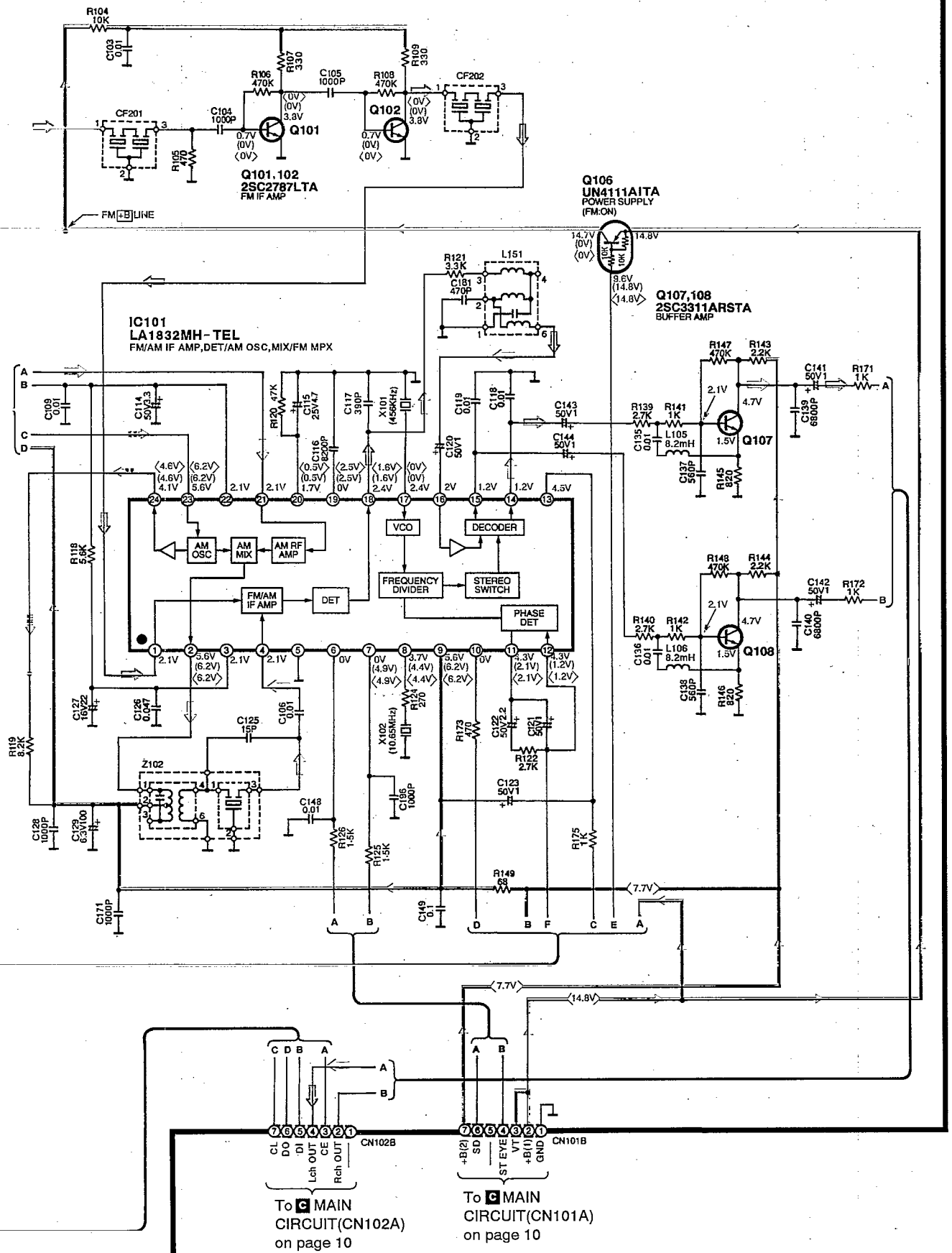

A TUNER CIRCUIT For [EG] area. (P.C. Board: on page 18)

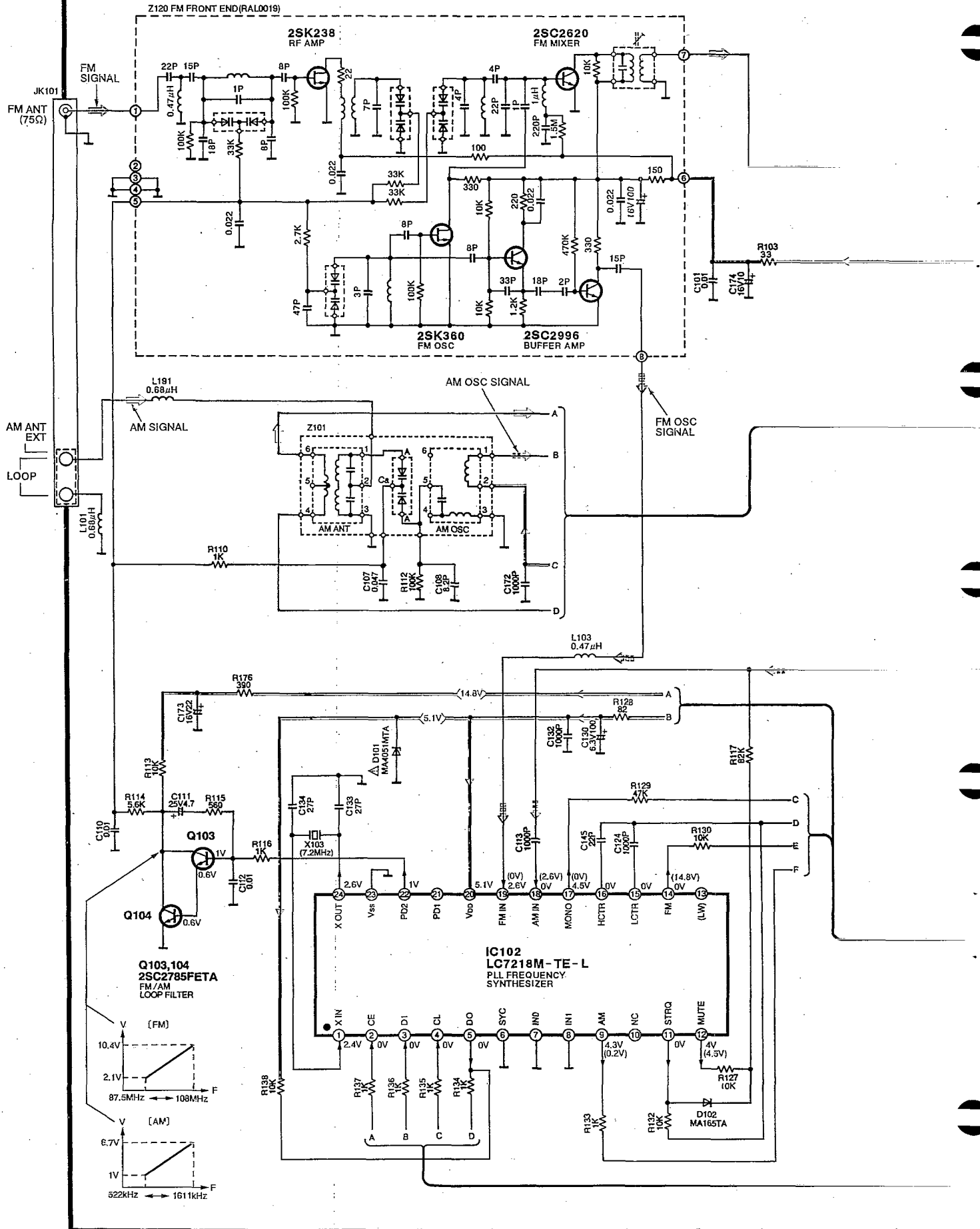

: Positive voltage line
 : AM signal line
 : FM signal line
 : AM OSC signal line
 : FM OSC signal line

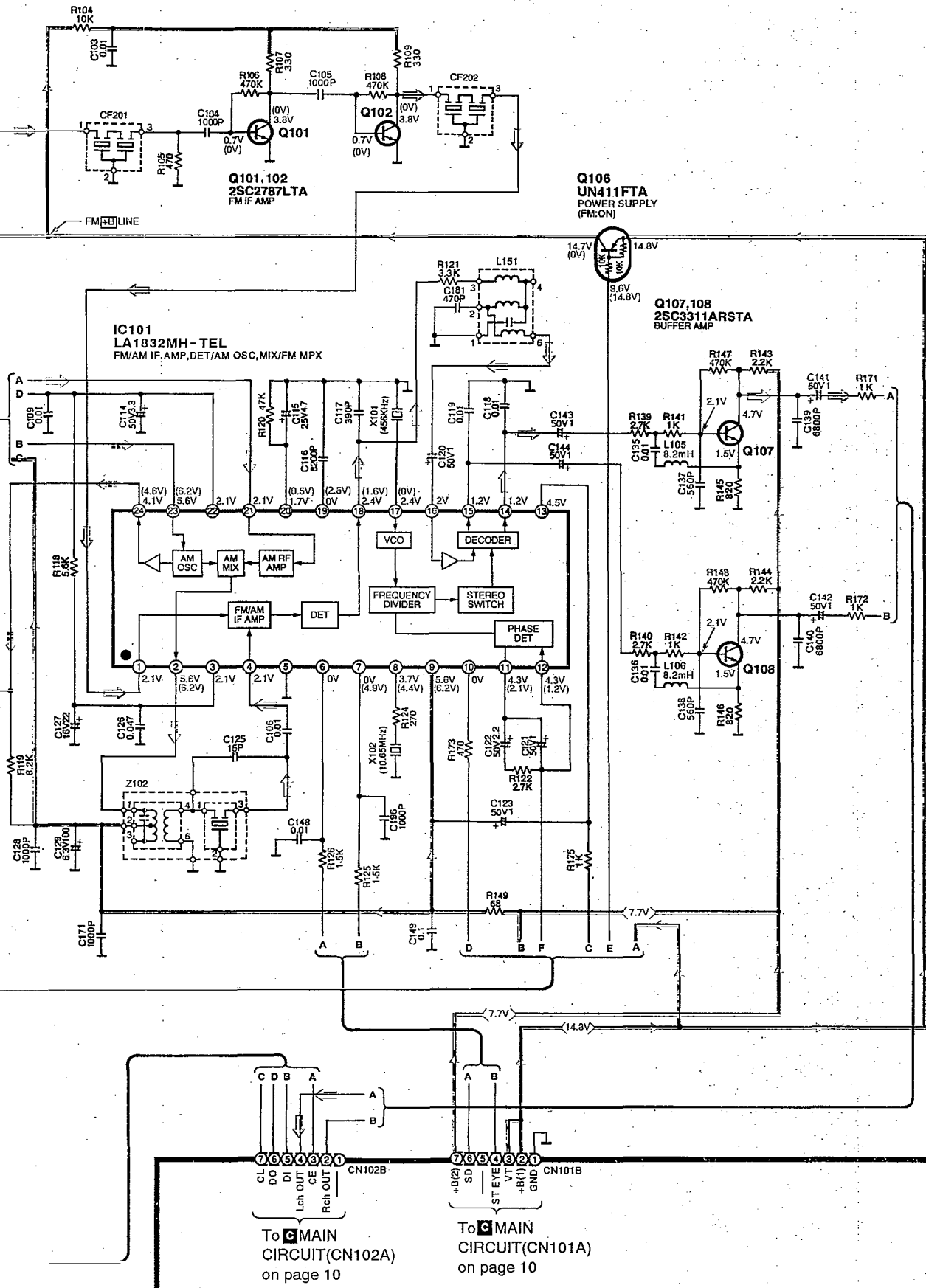

B OPERATION CIRCUIT (P.C.Board : on page 20)

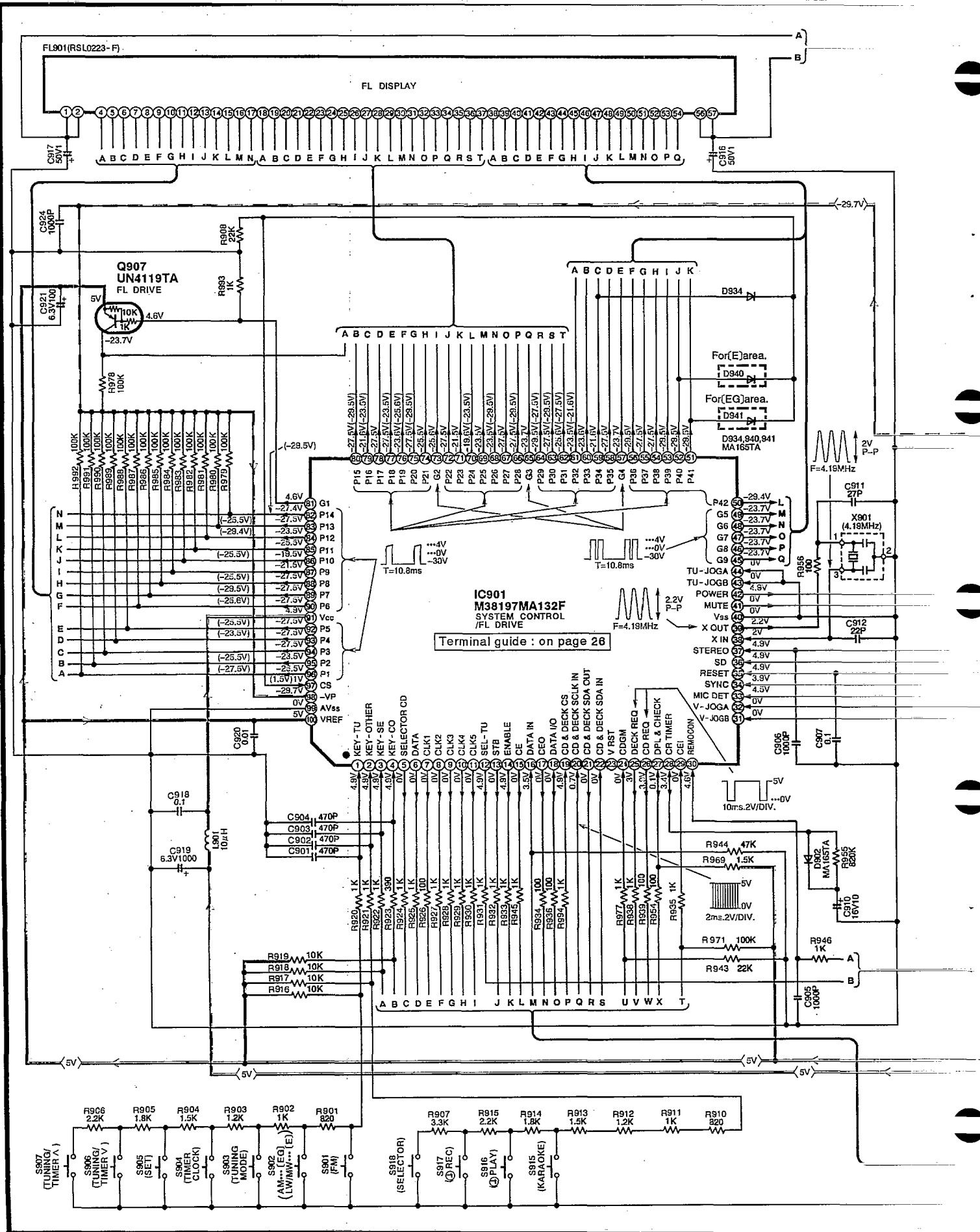

→ : Positive voltage line ← : Negative voltage line

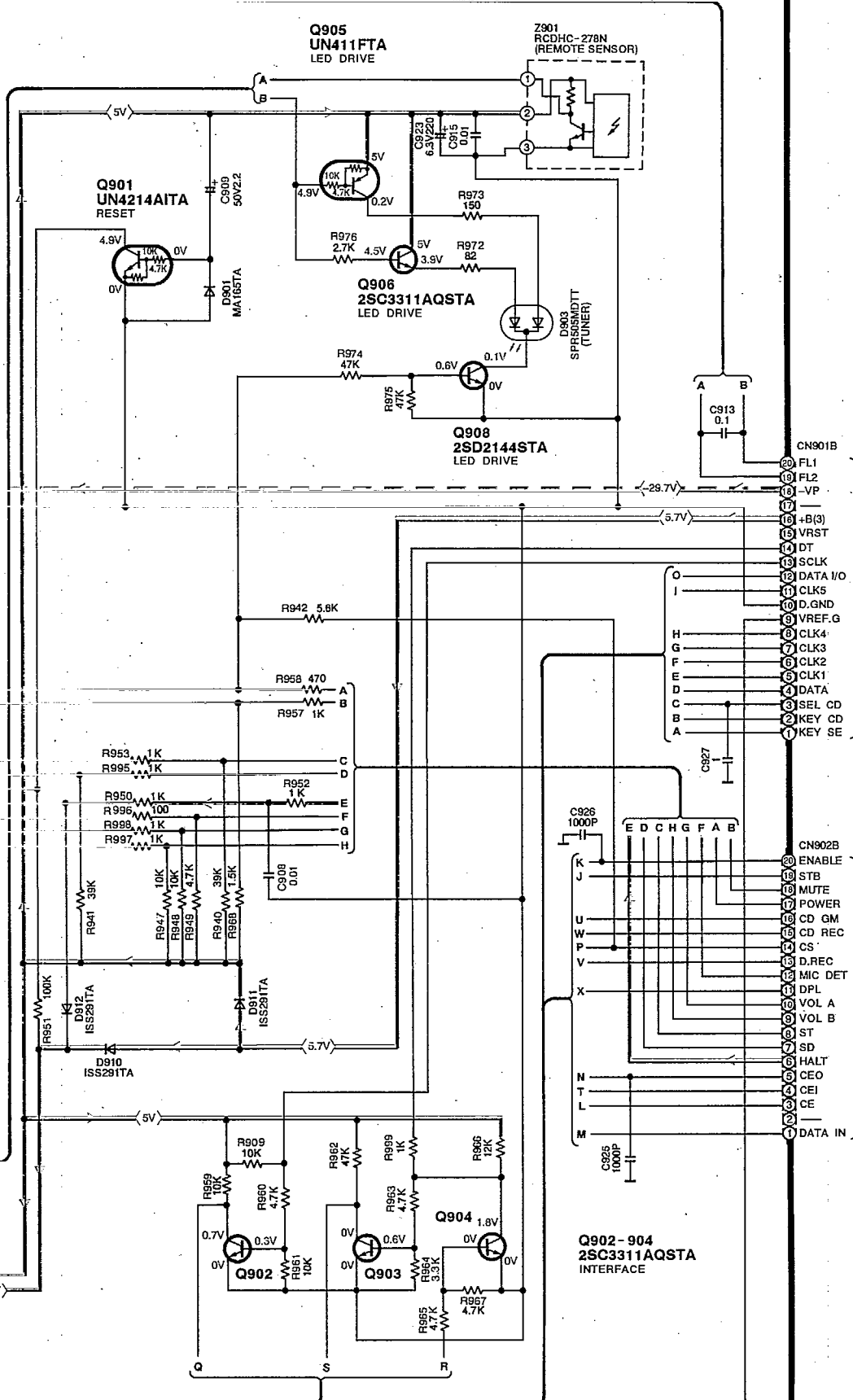

To MAIN CIRCUIT (CN901A) on page 11

To MAIN CIRCUIT (CN902A) on page 10

Printed Circuit Board Diagram

• This circuit board diagram may be modified at any time with the development of new technology.

A TUNER P.C.B. (REP1930F-T)
For [E] area.

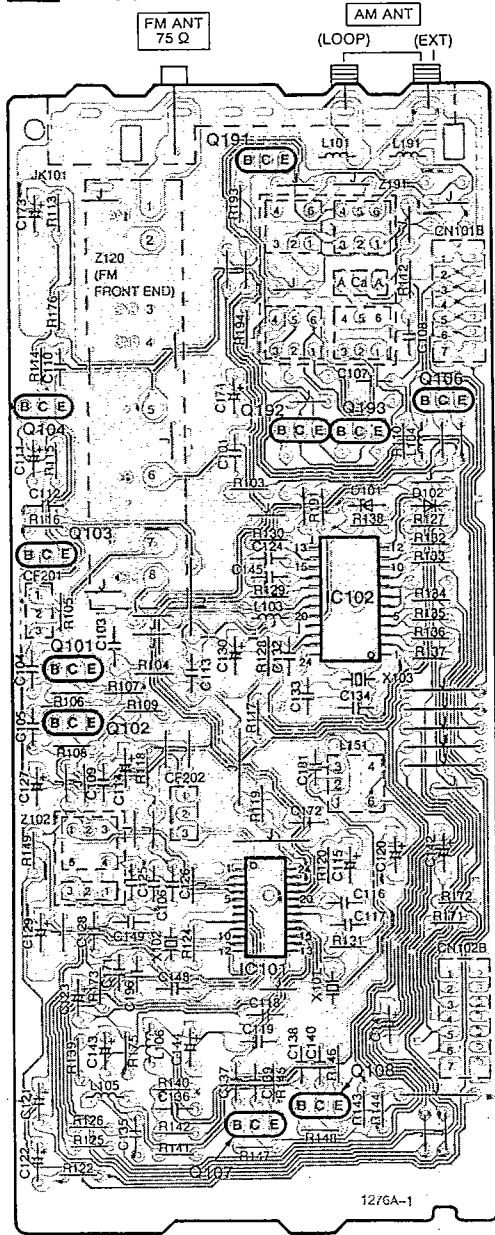

A TUNER P.C.B. (REP1930B-T)
For [EG] area.

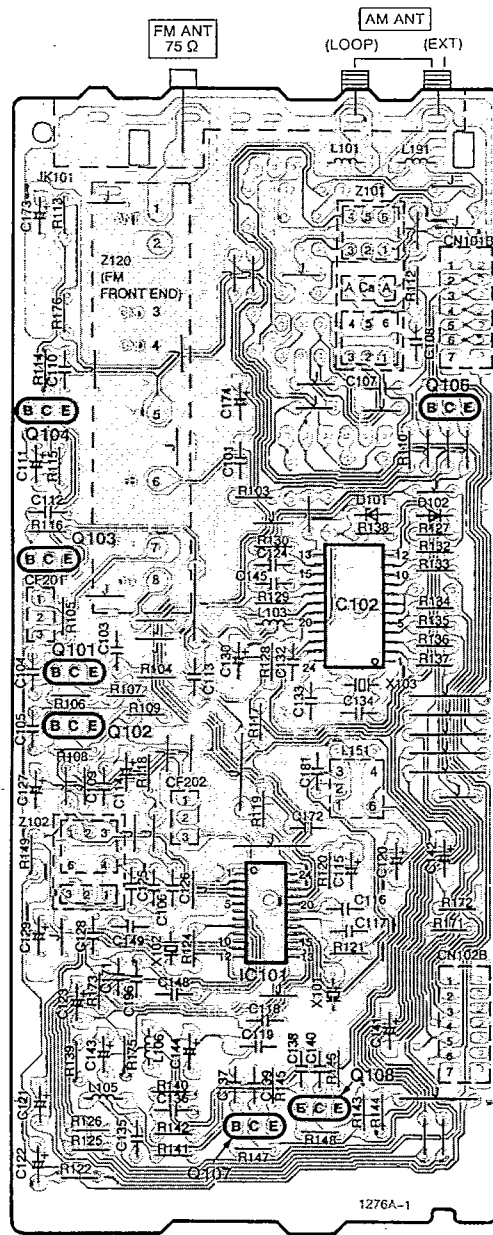

C MAIN P.C.B. (REP2120N-M)

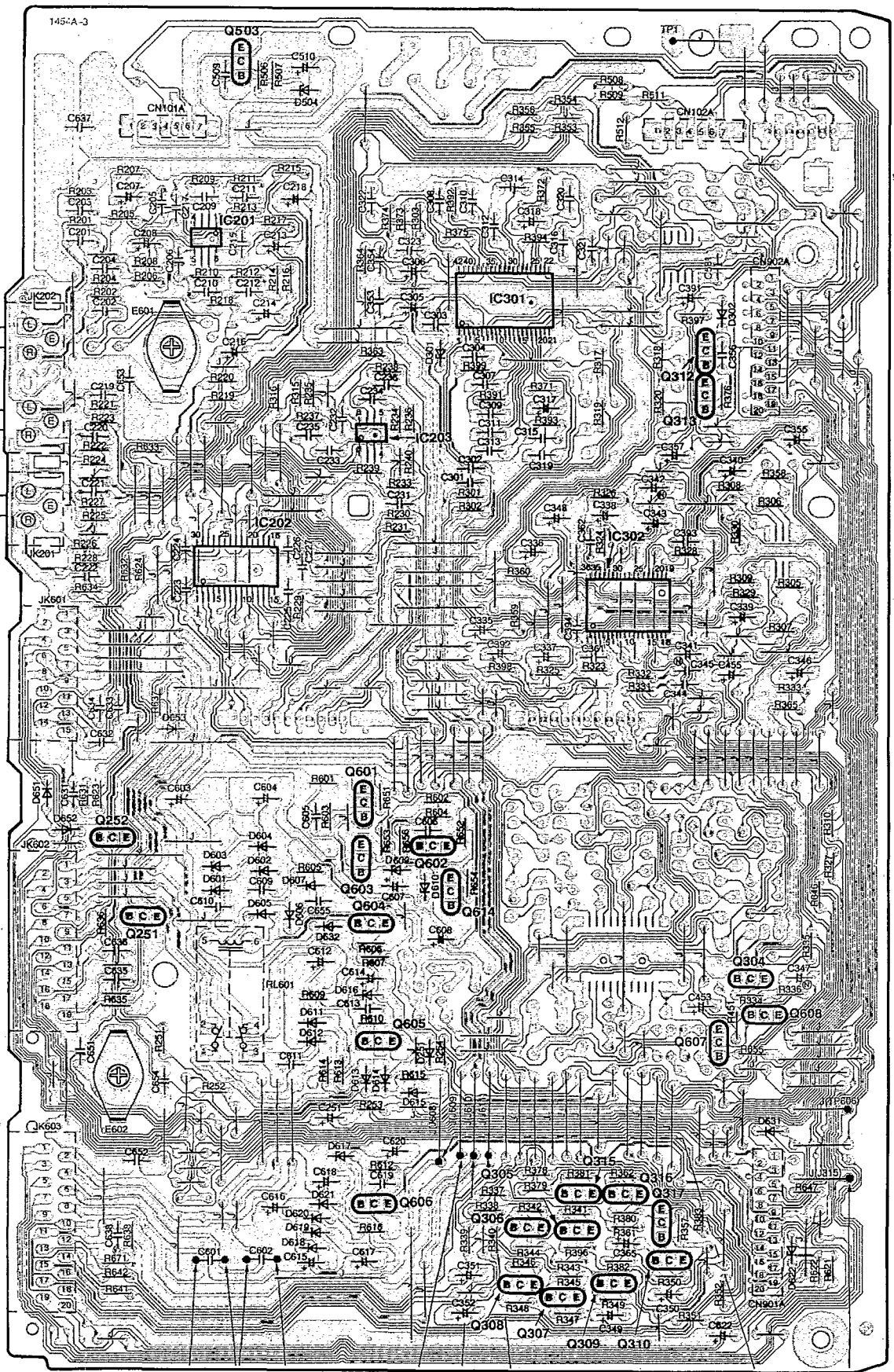

PHONO
GND
EXTERNAL
(IN)
(OUT)

RS-CH770

SL-CH570

SE-CH540

TP601 (AC) TP602 (CT) TP603 (AC)
TP609 (T.GND) TP608 A.GND
POWER SUPPLY POINT

TP610 (D.GND) TP611
SHORT:POWER 'ON'

B OPERATION P.C.B. (REP2365K-S...[E]
REP2365L-S...[EG])

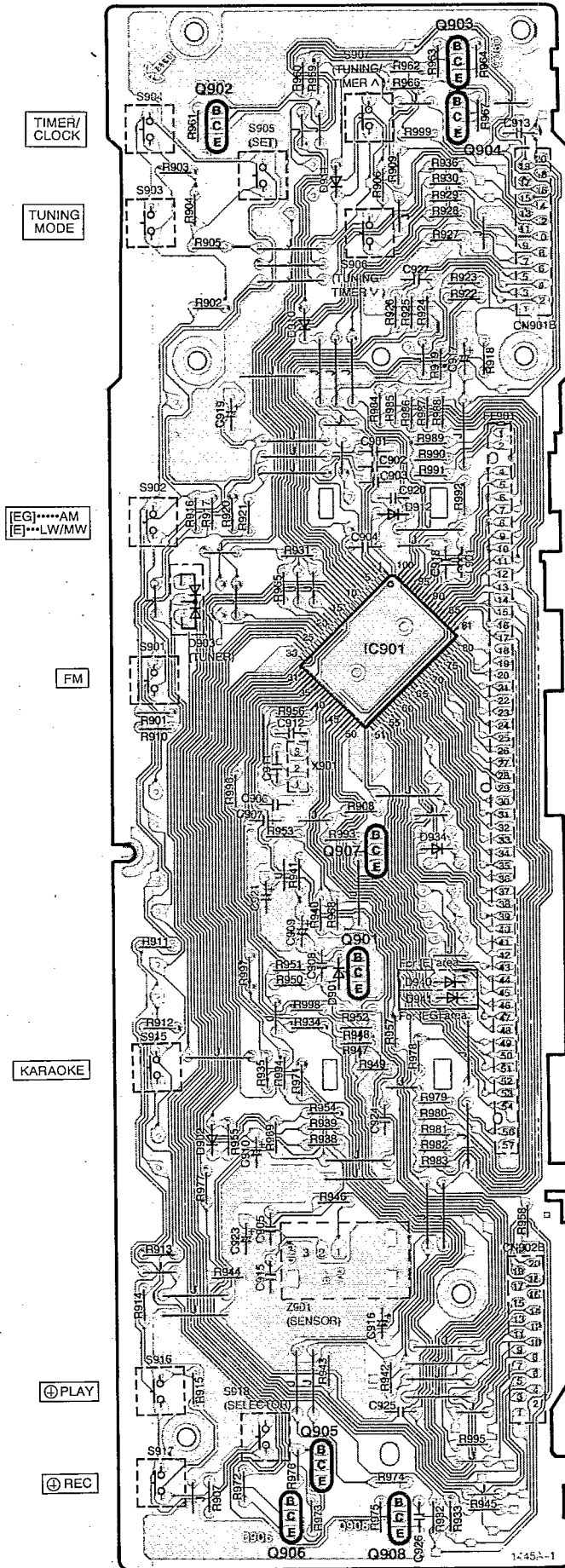

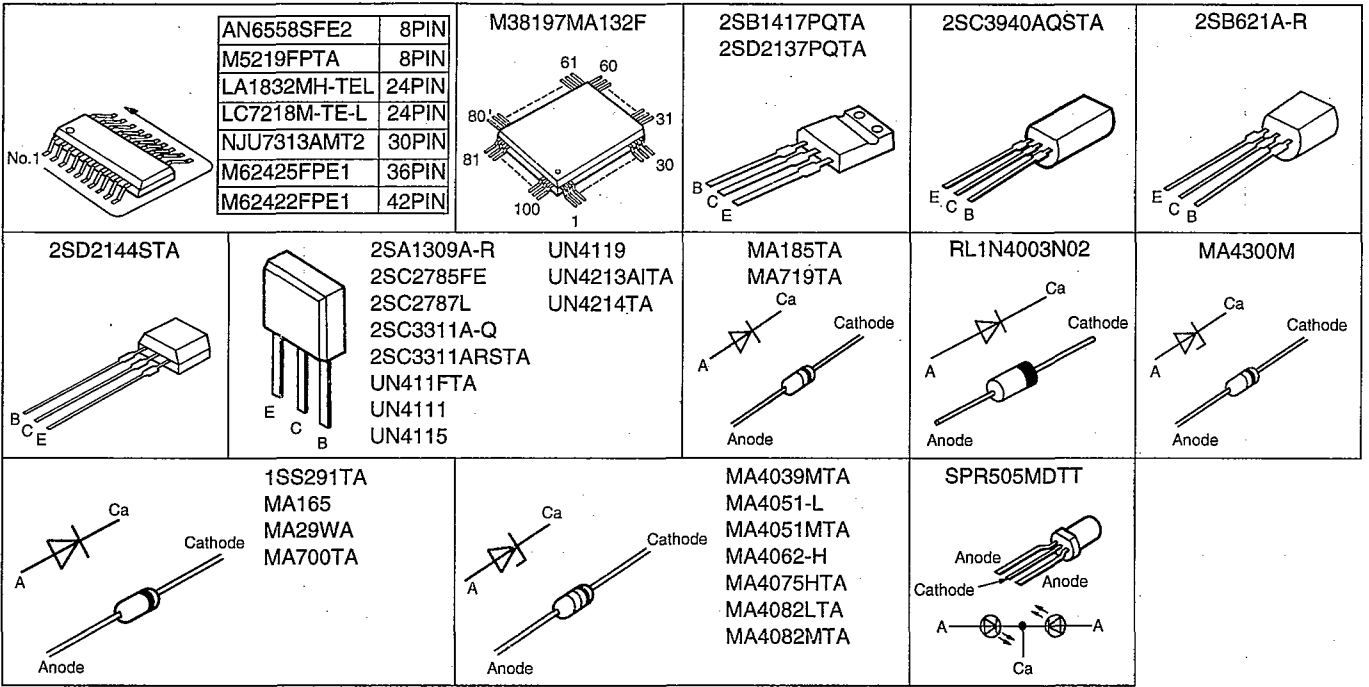

■ Wiring Connection Diagram

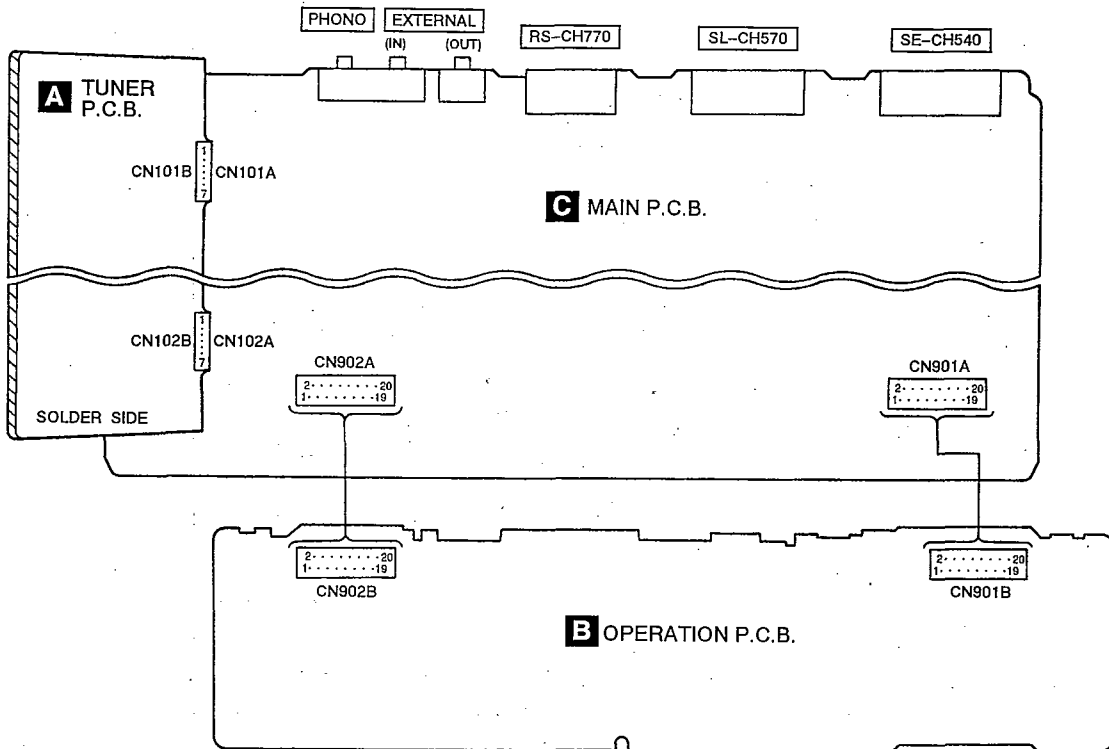

Block Diagram

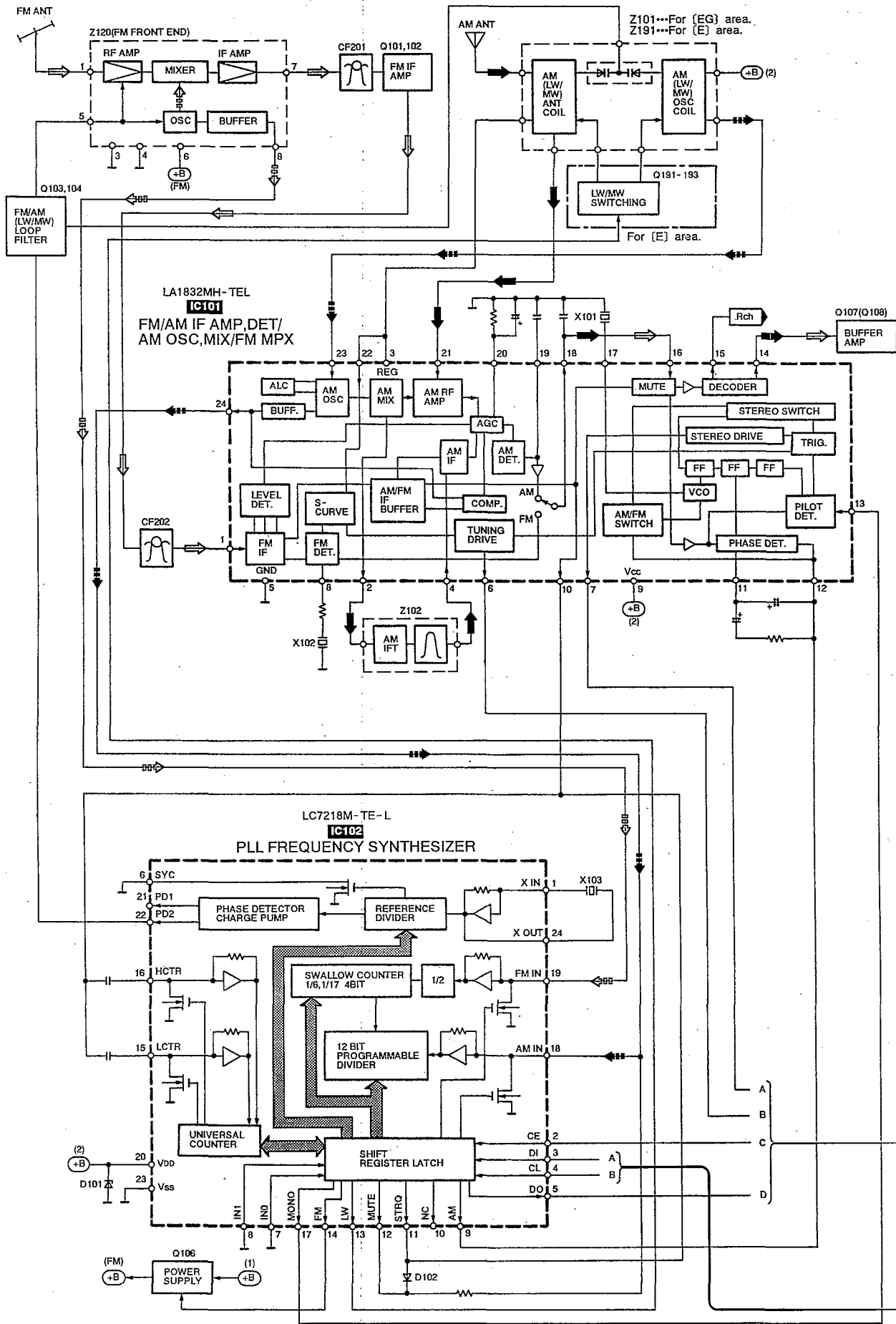

NJU7313AMT2
IC202
 INPUT SELECTOR

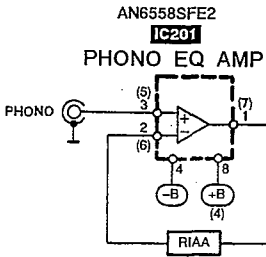

M5219FPTA
IC203
 BUFFER AMP

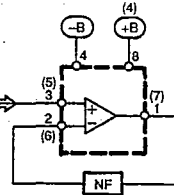

Lch IN/CD (JK602, 19PIN)

Q251 (Q252) SWITCHING

LINE IN/Lch/TAPE (JK601, 15PIN)

EXTERNAL
 IN
 OUT

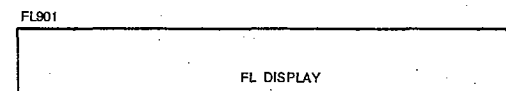
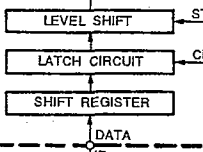

M38197MA132F
IC901(1/2)
 SYSTEM CONTROL/
 FL DRIVE

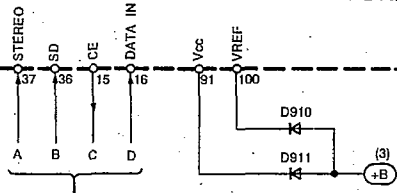

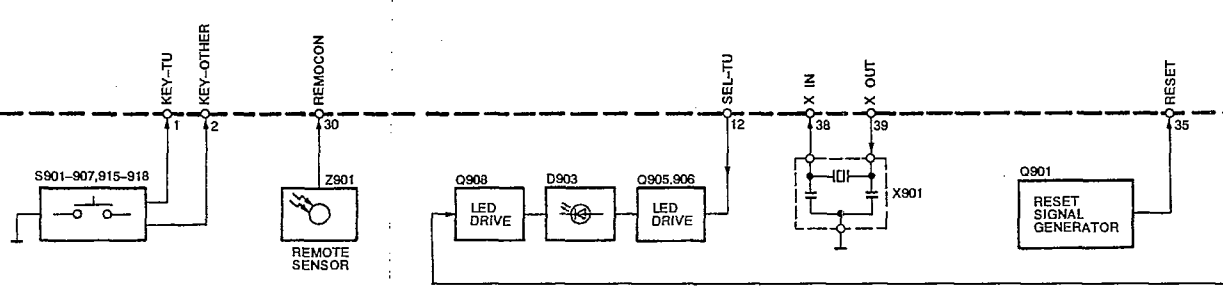
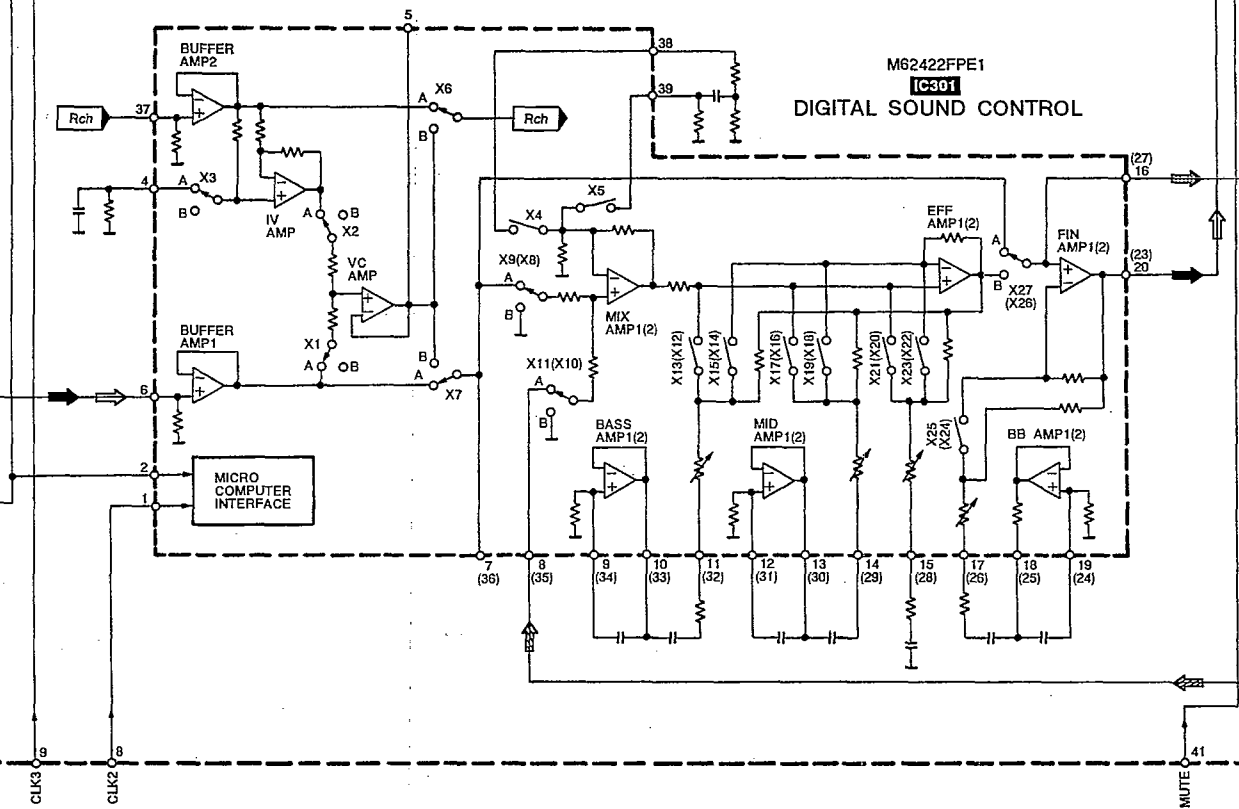
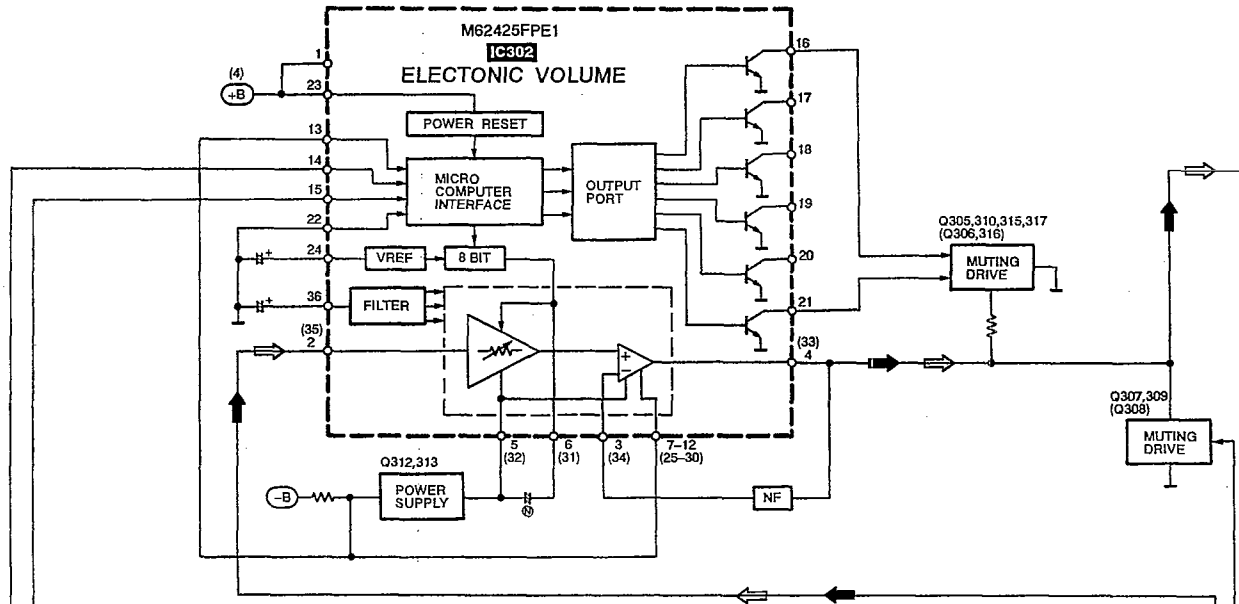

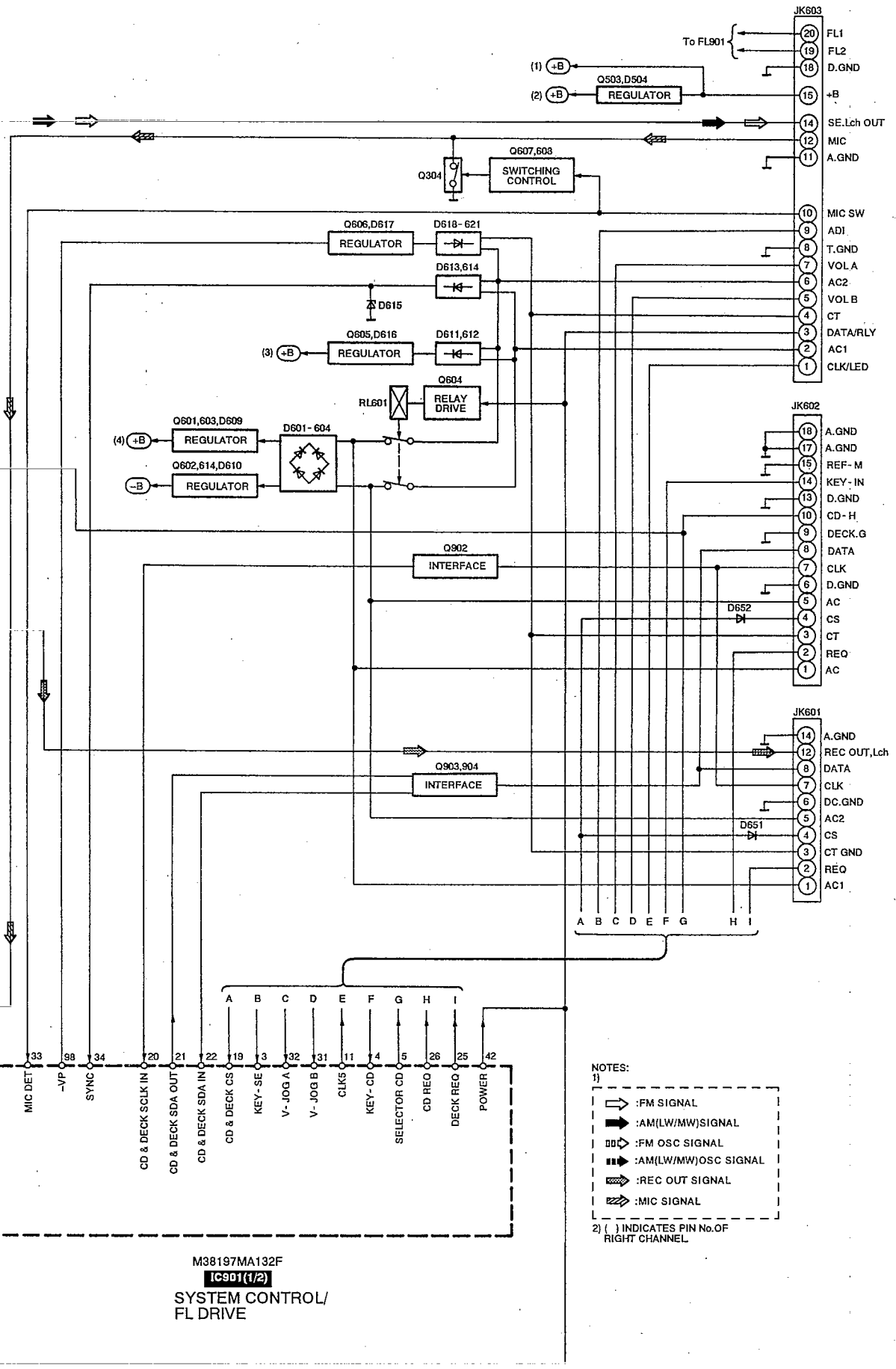

M38197MA192F
IC9D1(1/2)
 SYSTEM CONTROL/
 FL DRIVE

- NOTES:
- : FM SIGNAL
 - - - - : AM(LW/MW) SIGNAL
 - ... : FM OSC SIGNAL
 - ▨▨▨ : AM(LW/MW) OSC SIGNAL
 - ▨▨▨▨▨ : REC OUT SIGNAL
 - ▨▨▨▨▨▨▨ : MIC SIGNAL
 - () INDICATES PIN No. OF RIGHT CHANNEL.

■ Function of IC Terminals

● IC901 (M38197MA132F)

Pin No.	Terminal Name	I/O	Function
1	KEY-TU	I	Tuner operation switch signal input
2	KEY-OTHER	I	Other operation switch signal input
3	KEY-SE	I	SE-CH540 operation switch signal input
4	KEY-CD	I	SL-CH570 operation switch signal input
5	SELECTOR CD	O	SL-CH570 power control signal output
6	DATA	O	Data output for NJU7313, M62422, M62425, LC7218, LA2785 and LV1011
7	CLK1	O	Clock output for NJU7313, LC7218, LA2785, LV1011 and LC65104
8	CLK2	O	Clock output for M62422 (Digitalsound controller)
9	CLK3	O	Clock output for M62425 (Main volume)
10	CLK4	O	Clock output for M62425 (Surround volume)
11	CLK5	O	LED (D601, D602) (SE-CH540) drive signal output
12	SEL_TU	O	LED (D903-TUNER ON) drive signal output
13	STB	O	STB signal output for NJU7313
14	ENABLE	O	Enable signal output for LA2785 and LV1011
15	CE	O	Chip enable signal output for LC7218
16	DATA IN	I	Data input from LC7218
17	CEO	O	Not used
18	DATA I/O	I/O	Not used
19	CD & DECK CS	I	Serial data communication starting signal input
20	CD & DECK SCLK IN	I	Serial clock input
21	CD & DECK SDA OUT	O	Serial data output
22	CD & DECK SDA IN	I	Serial data input
23	V RST	—	Not used
24	CDGM	—	Not used
25	DECK REQ	O	RS-CH770 request signal output
26	CD REQ	O	SL-CH570 request signal output
27	DPL & CHECK	I/O	Clock check signal
28	CR TIMER	I/O	Capacitor and resistor oscillation terminal
29	CEI	I	Not used
30	REMOCON	I	Remote control signal input
31	V-JOGB	I	Volume control signal input
32	V-JOGA	I	

Pin No.	Terminal Name	I/O	Function
33	MIC DET	I	Microphone connecting detect signal input
34	SYNC	I	AC power source input terminal
35	RESET	I	Reset signal input
36	SD	I	SD signal input for tuner circuit
37	STEREO	I	STEREO signal input for tuner circuit
38	X IN	I	Connected to the ceramic oscillator
39	X OUT	O	
40	Vss	—	GND terminal
41	MUTE	O	Muting signal output
42	POWER	O	Power control signal output
43	TU-JOGB	I	Not used
44	TU-JOGA	I	
45-49	G9 ~ G5	O	Grid signal output
50-56	P42 ~ P36	O	Segment signal output
57	G4	O	Grid signal output
58-64	P35 ~ P29	O	Segment signal output
65	G3	O	Grid signal output
66-72	P28 ~ P22	O	Segment signal output
73	G2	O	Grid signal output
74-80	P21 ~ P15	O	Segment signal output
81	G1	O	Grid signal output
82-90	P14 ~ P6	O	Segment signal output
91	VCC	—	Power supply (+5V)
92-96	P5 ~ P1	O	Segment signal output
97	CS	I	Scan signal input
98	-VP	—	Negative power supply
99	AVSS	—	Connect to GND
100	VREF	—	Reference voltage input

Replacement Parts List

Notes: *Important safety notice:

 Components identified by Δ mark have special characteristics important for safety.

Furthermore, special parts which have purposes of fire-retardant (resistors), high-quality sound (capacitors), low-noise (resistors), etc. are used.

When replacing any of components, be sure to use only manufacture's specified parts shown in the parts list.

*The parenthesized indications in the Remarks columns specify the areas. (Refer to the cover page for area.)

Parts without these indications can be used for all areas.

Ref. No.	Part No.	Part Name & Description	Remarks	Ref. No.	Part No.	Part Name & Description	Remarks
		INTEGRATED CIRCUIT (S)		D101	MA4051MTA	DIODE	Δ
IC101	LA1832MH-TEL	IC, FM/AM(LW/MW) IF AMP.		D102	MA165	DIODE	
IC102	LC7218M-TE-L	IC, PLL FREQ. SYNTHESIZER		D251	MA29WA	DIODE	
IC201	AN6558SFE2	IC, PHONO EQ AMP.		D301	MA4051-L	DIODE	Δ
IC202	NJU7313AMT2	IC, INPUT SELECTOR		D302	MA165	DIODE	
IC203	M5219FPTA	IC, BUFFER AMP.		D504	MA4082MTA	DIODE	Δ
IC301	M62422FPE1	IC, DIGITAL SOUND CONT.		D601-604	RL1N4003N02	DIODE	Δ
IC302	M62425FPE1	IC, ELECTRONIC VOLUME		D605	MA165	DIODE	
IC901	M38197MA132F	IC, SYSTEM CONTROL/FL DRIVE		D606, 607	MA719TA	DIODE	
		TRANSISTOR (S)		D609	MA4075HTA	DIODE	Δ
				D610	MA4082LTA	DIODE	Δ
Q101, 102	2SC2787L	TRANSISTOR		D611, 612	RL1N4003N02	DIODE	Δ
Q103, 104	2SC2785FE	TRANSISTOR		D613, 614	MA185TA	DIODE	Δ
Q106	UN4111	TRANSISTOR	(E)	D615	MA4051MTA	DIODE	Δ
Q106	UN411FTA	TRANSISTOR	(EG)	D616	MA4062-H	DIODE	Δ
Q107, 108	2SC3311ARSTA	TRANSISTOR		D617	MA4300M	DIODE	Δ
Q191-193	2SC3311ARSTA	TRANSISTOR	(E)	D618-621	MA185TA	DIODE	Δ
Q251, 252	2SD2144S	TRANSISTOR		D622	MA4039MTA	DIODE	Δ
Q304	2SD2144S	TRANSISTOR		D631	MA700TA	DIODE	
Q305, 306	2SC3311A-Q	TRANSISTOR		D632	MA165	DIODE	
Q307, 308	2SD2144S	TRANSISTOR		D651, 652	MA165	DIODE	
Q309, 310	UN4115	TRANSISTOR		D653	MA719TA	DIODE	
Q312, 313	2SA1309A-R	TRANSISTOR		D901, 902	MA165	DIODE	
Q315, 316	2SC3311A-Q	TRANSISTOR		D903	SPR505MDTT	L. E. D	
Q317	UN4115	TRANSISTOR		D910-912	1SS291TA	DIODE	
Q503	2SC3940AQSTA	TRANSISTOR	Δ	D934	MA165	DIODE	
Q601	2SD2137PQTA	TRANSISTOR	Δ	D940	MA165	DIODE	(E)
Q602	2SB1417PQTA	TRANSISTOR	Δ	D941	MA165	DIODE	(EG)
Q603	2SD2137PQTA	TRANSISTOR	Δ			COMPONENT COMBINATION (S)	
Q604	2SD2144S	TRANSISTOR		Z101	RLA2Z002M-T	COMPONENT COMBINATION	(EG)
Q605	2SD2137PQTA	TRANSISTOR	Δ	Z102	RL12Z006M-T	COMPONENT COMBINATION	
Q606	2SB621A-R	TRANSISTOR	Δ	Z120	RAL0019	FM FRONT END	
Q607	UN4213AITA	TRANSISTOR		Z191	RLA6Z005M-T	COMPONENT COMBINATION	(E)
Q608	UN4111	TRANSISTOR		Z901	RCDHC-278N	REMOTE SENSOR	
Q614	2SB1417PQTA	TRANSISTOR	Δ			COIL (S)	
Q901	UN4214TA	TRANSISTOR					
Q902-904	2SC3311A-Q	TRANSISTOR		L101	ELESNR68MA	COIL	
Q905	UN411FTA	TRANSISTOR		L103	ELEXT47MA9	COIL	
Q906	2SC3311A-Q	TRANSISTOR		L104	ELEXT1R0KA9	COIL	(E)
Q907	UN4119	TRANSISTOR		L105, 106	ELELN822KL	COIL	
Q908	2SD2144S	TRANSISTOR		L151	SLM1B10M-1M	COIL	
		DIODE (S)		L191	ELESNR68MA	COIL	

Ref. No.	Part No.	Part Name & Description	Remarks	Ref. No.	Part No.	Part Name & Description	Remarks
L901	RLQA100JT-Y	COIL				JACK(S)	
		FILTER(S)		JK101	RJH5210M	EXT ANT	
				JK201	SJF3068-7N	EXT OUT	
CF201	RLFFETNGD01L	CERAMIC FILTER		JK202	SJF3069-5N	EXT IN/PHONO	
CF202	RLFFETMGD01L	CERAMIC FILTER		JK601	RJT065K15	SYSTEM CONNECTOR(15P)	
		OSCILLATOR(S)		JK602	RJT065K19	SYSTEM CONNECTOR(19P)	
				JK603	RJT065K20	SYSTEM CONNECTOR(20P)	
X101	RSXZ456KM07M	OSCILLATOR(456 kHz)					
X102	RLFDGT05DD	OSCILLATOR(10.65 MHz)					
X103	RSXC7M20S05T	OSCILLATOR(7.2 MHz)					
X901	RSXC4M19S02T	OSCILLATOR(4.19 MHz)					
		DISPLAY TUBE					
FL901	RSL0223-F	DISPLAY TUBE					
		SWITCH(ES)					
S901	EVQ21405R	SW, FM					
S902	EVQ21405R	SW, AM(LW/MW)					
S903	EVQ21405R	SW, TUNING MODE					
S904	EVQ21405R	SW, TIMER/CLOCK					
S905	EVQ21405R	SW, SET					
S906	EVQ21405R	SW, TUNING/TIMER DOWN					
S907	EVQ21405R	SW, TUNING/TIMER UP					
S915	EVQ21405R	SW, KARAOKE					
S916	EVQ21405R	SW, PLAY TIMER					
S917	EVQ21405R	SW, RECORD TIMER					
S918	EVQ21405R	SW, SELECTOR					
		CONNECTOR(S)					
CN101A	RJT057W007-1	CONNECTOR(7P)					
CN101B	RJU057W007	CONNECTOR(7P)					
CN102A	RJT057W007-1	CONNECTOR(7P)					
CN102B	RJU057W007	CONNECTOR(7P)					
CN901A	RJS1A6820	CONNECTOR(20P)					
CN901B	RJS1A6820	CONNECTOR(20P)					
CN902A	RJS1A6820	CONNECTOR(20P)					
CN902B	RJS1A6820	CONNECTOR(20P)					
		GND PLATE					
E601, 602	SNE1004-2	GND PLATE					
		RELAY					
RL601	RSY0017M-0	RELAY	△				

Notes : * Capacity values are in microfarads (μF) unless specified otherwise, P=Pico-farads (pF) F=Farads (F)
 * Resistance values are in ohms, unless specified otherwise, 1K=1,000 (OHM) , 1M=1,000k(OHM)

Ref. No.	Part No.	Values & Remarks	Ref. No.	Part No.	Values & Remarks	Ref. No.	Part No.	Values & Remarks
		RESISTORS	R205, 206	ERDS2TJ331	1/4W 330	R352	ERDS2TJ182	1/4W 1.8K
			R207, 208	ERDS2TJ271	1/4W 270	R353, 354	ERDS2TJ102	1/4W 1K
			R209, 210	ERDS2TJ184T	1/4W 180K	R355, 356	ERDS2TJ104	1/4W 100K
R103	ERDS2TJ101	1/4W 100 (E)	R211, 212	ERDS2TJ123	1/4W 12K	R357	ERDS2TJ105T	1/4W 1M
R103	ERDS2TJ330T	1/4W 33 (EG)	R213, 214	ERDS2TJ680T	1/4W 68	R358	ERDS2TJ100	1/4W 10
R104	ERDS2TJ103	1/4W 10K	R215, 216	ERDS2TJ272T	1/4W 2.7K	R359	ERDS2TJ473	1/4W 47K
R105	ERDS2TJ471	1/4W 470	R217, 218	ERDS2TJ392T	1/4W 3.9K	R360	ERDS2TJ473	1/4W 47K
R106	ERDS2TJ474	1/4W 470K	R219, 220 Δ	ERDS1FVJ221T	1/2W 220	R361	ERDS2TJ102	1/4W 1K
R107	ERDS2TJ331	1/4W 330	R221, 222	ERDS2TJ752T	1/4W 7.5K	R362	ERDS2TJ223	1/4W 22K
R108	ERDS2TJ474	1/4W 470K	R223, 224	ERDS2TJ562	1/4W 5.6K	R363, 364	ERDS2TJ473	1/4W 47K
R109	ERDS2TJ331	1/4W 330	R225, 226	ERDS2TJ472	1/4W 4.7K	R365	ERDS2TJ102	1/4W 1K
R110	ERDS2TJ102	1/4W 1K	R227, 228	ERDS2TJ332	1/4W 3.3K	R371, 372	ERDS2TJ100	1/4W 10
R112	ERDS2TJ104	1/4W 100K	R229-231	ERDS2TJ222	1/4W 2.2K	R373, 374	ERDS2TJ224T	1/4W 220K
R113	ERDS2TJ103	1/4W 10K	R233, 234	ERDS2TJ223	1/4W 22K	R375	ERDS2TJ103	1/4W 10K
R114	ERDS2TJ562	1/4W 5.6K	R235, 236	ERDS2TJ822	1/4W 8.2K	R376	ERDS2TJ223	1/4W 22K
R115	ERDS2TJ561	1/4W 560	R237, 238	ERDS2TJ123	1/4W 12K	R378, 379	ERDS2EJ121	1/4W 120
R116	ERDS2TJ102	1/4W 1K	R239, 240	ERDS2TJ102	1/4W 1K	R380	ERDS2TJ102	1/4W 1K
R117	ERDS2TJ823T	1/4W 82K	R251, 252	ERDS2TJ222	1/4W 2.2K	R381	ERDS2TJ223	1/4W 22K
R118	ERDS2TJ562	1/4W 5.6K	R253	ERDS2TJ223	1/4W 22K	R382	ERDS2TJ105T	1/4W 1M
R119	ERDS2TJ822	1/4W 8.2K	R254	ERDS2TJ222	1/4W 2.2K	R383	ERDS2TJ472	1/4W 4.7K
R120	ERDS2TJ473	1/4W 47K	R301, 302	ERDS2TJ222	1/4W 2.2K	R391, 392	ERDS2TJ222	1/4W 2.2K
R121	ERDS2TJ332	1/4W 3.3K	R303	ERDS2TJ102	1/4W 1K	R393, 394	ERDS2TJ100	1/4W 10
R122	ERDS2TJ272T	1/4W 2.7K	R305-307	ERDS2TJ100	1/4W 10	R396	ERDS2TJ102	1/4W 1K
R124	ERDS2TJ271	1/4W 270	R308, 309	ERDS2TJ223	1/4W 22K	R397	ERDS2TJ150T	1/4W 15
R125, 126	ERDS2TJ152	1/4W 1.5K	R310	ERDS2TJ182	1/4W 1.8K	R398	ERDS2TJ1R0	1/4W 1.0
R127	ERDS2TJ103	1/4W 10K	R315, 316	ERDS2TJ102	1/4W 1K	R399	ERDS2TJ105T	1/4W 1M
R128	ERDS2TJ820	1/4W 82	R317, 318	ERDS2TJ471	1/4W 470	R451	ERDS2TJ102	1/4W 1K
R129	ERDS2TJ473	1/4W 47K	R319	ERDS2TJ103	1/4W 10K	R506	ERDS2TJ152	1/4W 1.5K
R130	ERDS2TJ103	1/4W 10K	R320	ERDS2TJ103	1/4W 10K	R507	ERDS2TJ331	1/4W 330
R132	ERDS2TJ103	1/4W 10K	R323, 324	ERDS2TJ103	1/4W 10K	R508, 509	ERDS2TJ473	1/4W 47K
R133-137	ERDS2TJ102	1/4W 1K	R325	ERDS2TJ682T	1/4W 6.8K	R511, 512	ERDS2TJ103	1/4W 10K
R138	ERDS2TJ103	1/4W 10K	R326	ERDS2TJ682T	1/4W 6.8K	R601, 602 Δ	ERD2FCVJ4R7T	1/4W 4.7
R139, 140	ERDS2TJ272T	1/4W 2.7K	R327, 328	ERDS2TJ182	1/4W 1.8K	R603, 604	ERDS2TJ102	1/4W 1K
R141, 142	ERDS2TJ102	1/4W 1K	R329, 330	ERDS2TJ102	1/4W 1K	R605	ERDS2TJ101	1/4W 100
R143, 144	ERDS2TJ222	1/4W 2.2K	R331, 332	ERDS2TJ222	1/4W 2.2K	R606, 607	ERDS2TJ393	1/4W 39K
R145, 146	ERDS2TJ821	1/4W 820	R333	ERDS2TJ104	1/4W 100K	R609 Δ	ERD2FCVJ4R7T	1/4W 4.7
R147, 148	ERDS2TJ474	1/4W 470K	R334	ERDS2TJ102	1/4W 1K	R610	ERDS2TJ102	1/4W 1K
R149	ERDS2TJ680T	1/4W 68	R335	ERDS2TJ104	1/4W 100K	R612	ERDS2TJ472	1/4W 4.7K
R171, 172	ERDS2TJ102	1/4W 1K	R336	ERDS2TJ223	1/4W 22K	R613, 614	ERDS2TJ682T	1/4W 6.8K
R173	ERDS2TJ471	1/4W 470	R337, 338	ERDS2TJ391	1/4W 390	R615	ERDS2TJ103	1/4W 10K
R175	ERDS2TJ102	1/4W 1K	R339, 340	ERDS2TJ122	1/4W 1.2K	R616 Δ	ERD2FVJ4R7T	1/4W 4.7
R176	ERDS2TJ391	1/4W 390	R341, 342	ERDS2TJ104	1/4W 100K	R621, 622	ERDS2TJ151	1/4W 150
R191	ERDS2TJ103	1/4W 10K (E)	R343	ERDS2TJ105T	1/4W 1M	R623, 624	ERDS2TJ682T	1/4W 6.8K
R192	ERDS2TJ122	1/4W 1.2K (E)	R344	ERDS2TJ102	1/4W 1K	R631-634	ERDS2TJ102	1/4W 1K
R193	ERDS2TJ182	1/4W 1.8K (E)	R345, 346	ERDS2TJ104	1/4W 100K	R635, 636	ERDS2TJ222	1/4W 2.2K
R194	ERDS2TJ122	1/4W 1.2K (E)	R347, 348	ERDS2TJ102	1/4W 1K	R637	ERDS2TJ100	1/4W 10
R195	ERDS2TJ222	1/4W 2.2K (E)	R349	ERDS2TJ104	1/4W 100K	R638	ERDS2TJ103	1/4W 10K
R201, 202	ERDS2TJ102	1/4W 1K	R350	ERDS2TJ105T	1/4W 1M	R641, 642	ERDS2TJ471	1/4W 470
R203, 204	ERDS2TJ473	1/4W 47K	R351	ERDS2TJ222	1/4W 2.2K	R646	ERDS2TJ223	1/4W 22K

Ref. No.	Part No.	Values & Remarks	Ref. No.	Part No.	Values & Remarks	Ref. No.	Part No.	Values & Remarks
R647	ERDS2TJ473	1/4W 47K	R965	ERDS2TJ472	1/4W 4. 7K	C173	ECEA1CKA220B	16V 22U
R651-654	ERDS2TJ2R2T	1/4W 2. 2	R966	ERDS2TJ123	1/4W 12K	C174	RCE1CKA100BG	16V 10U
R655	ERDS2TJ102	1/4W 1K	R967	ERDS2TJ472	1/4W 4. 7K	C181	ECBT1H471KB5	50V 470P
R656	ERDS2TJ221	1/4W 220	R968, 969	ERDS2TJ152	1/4W 1. 5K	C196	ECBT1H102KB5	50V 1000P
R671	ERDS2TJ102	1/4W 1K	R971	ERDS2TJ104	1/4W 100K	C201, 202	ECBT1H180J5	50V 18P
R901	ERDS2TJ821	1/4W 820	R972	ERDS2TJ820	1/4W 82	C203, 204	ECBT1H151KB5	50V 150P
R902	ERDS2TJ102	1/4W 1K	R973	ERDS2TJ151	1/4W 150	C205, 206	ECBT1H102KB5	50V 1000P
R903	ERDS2TJ122	1/4W 1. 2K	R974, 975	ERDS2TJ473	1/4W 47K	C207, 208	RCE1AKA330BG	10V 33U
R904	ERDS2TJ152	1/4W 1. 5K	R976	ERDS2TJ272T	1/4W 2. 7K	C209, 210	ECBTOJ223MS5	6. 3V 0. 022U
R905	ERDS2TJ182	1/4W 1. 8K	R977	ERDS2TJ102	1/4W 1K	C211, 212	ECBT1C682KR5	16V 6800P
R906	ERDS2TJ222	1/4W 2. 2K	R978-992	ERDS2TJ104	1/4W 100K	C213, 214	RCE1CKA100BG	16V 10U
R907	ERDS2TJ332	1/4W 3. 3K	R993-995	ERDS2TJ102	1/4W 1K	C215	ECBT1E103ZF	25V 0. 01U
R908	ERDS2TJ223	1/4W 22K	R996	ERDS2TJ101	1/4W 100	C216	RCE1CM101BV	16V 100U
R909	ERDS2TJ103	1/4W 10K	R997-999	ERDS2TJ102	1/4W 1K	C217	ECBT1E103ZF	25V 0. 01U
R910	ERDS2TJ821	1/4W 820				C218	RCE1AKA101BG	10V 100U
R911	ERDS2TJ102	1/4W 1K			CAPACITORS	C219-222	ECBT1H101KB5	50V 100P
R912	ERDS2TJ122	1/4W 1. 2K				C223, 224	ECBT1H104ZF5	50V 0. 1U
R913	ERDS2TJ152	1/4W 1. 5K	C101	ECBT1C103NS5	16V 0. 01U	C225-227	ECBT1H470J5	50V 47P
R914	ERDS2TJ182	1/4W 1. 8K	C103	ECBT1C103NS5	16V 0. 01U	C231, 232	ECBT1E103ZF	25V 0. 01U
R915	ERDS2TJ222	1/4W 2. 2K	C104, 105	ECBT1H102KB5	50V 1000P	C233, 234	ECBT1H102KB5	50V 1000P
R916-919	ERDS2TJ103	1/4W 10K	C106	ECBT1C103NS5	16V 0. 01U	C235, 236	ECBT1H101KB5	50V 100P
R920-922	ERDS2TJ102	1/4W 1K	C107	ECBT1H473ZF5	50V 0. 047U	C251	RCE1CKA470BG	16V 47U
R923	ERDS2TJ391	1/4W 390	C108	ECBT1H100JC5	50V 10P (E)	C301, 302	ECBT1H470J5	50V 47P
R924, 925	ERDS2TJ102	1/4W 1K	C108	ECBT1H8R2KC5	50V 8. 2P (EG)	C303	ECBT1E103ZF	25V 0. 01U
R926	ERDS2TJ101	1/4W 100	C109, 110	ECBT1C103NS5	16V 0. 01U	C304	ECFR1C473KR	16V 0. 047U
R927-933	ERDS2TJ102	1/4W 1K	C111	ECEA1EKA4R7B	25V 4. 7U	C305, 306	RCE1CKA100BG	16V 10U
R934	ERDS2TJ101	1/4W 100	C112	ECBT1C103NS5	16V 0. 01U	C307-310	ECFR1C104KR	16V 0. 1U
R935	ERDS2TJ102	1/4W 1K	C113	ECBT1H102KB5	50V 1000P	C311, 312	ECFR1C123KR	16V 0. 012U
R936	ERDS2TJ101	1/4W 100	C114	RCE1HKA3R3BG	50V 3. 3U	C313, 314	ECFR1C153KR	16V 0. 015U
R938	ERDS2TJ102	1/4W 1K	C115	ECEA1EKA4R7B	25V 4. 7U	C315, 316	ECBT1C332KR5	16V 3300P
R939	ERDS2TJ101	1/4W 100	C116	ECBT1C822KS5	16V 8200P	C317, 318	ECEA1HKA15B	50V 0. 15U
R940, 941	ERDS2TJ393	1/4W 39K	C117	ECQP1391JZ	100V 390P	C319, 320	ECFR1C104KR	16V 0. 1U
R942	ERDS2TJ562	1/4W 5. 6K	C118, 119	ECFR1C103KR	16V 0. 01U	C321	ECBT1E103ZF	25V 0. 01U
R943	ERDS2TJ223	1/4W 22K	C120, 121	ECEA1HKA010B	50V 1U	C322	ECFR1C473KR	16V 0. 047U
R944	ERDS2TJ473	1/4W 47K	C122	ECEA1HKA2R2B	50V 2. 2U	C323	ECFR1C103KR	16V 0. 01U
R945, 946	ERDS2TJ102	1/4W 1K	C123	ECEA1HKA010B	50V 1U	C335, 336	RCE1CKA100BG	16V 10U
R947, 948	ERDS2TJ103	1/4W 10K	C124	ECBT1H102KB5	50V 1000P	C337-340	ECEA1CKA220B	16V 22U
R949	ERDS2TJ472	1/4W 4. 7K	C125	ECBT1H150JC5	50V 15P	C341, 342	ECEA1AKN100B	10V 10U
R950	ERDS2TJ102	1/4W 1K	C126	ECBT1H473ZF5	50V 0. 047U	C343	RCE1CKA100BG	16V 10U
R951	ERDS2TJ104	1/4W 100K	C127	ECEA1CKA220B	16V 22U	C344, 345	ECBT1H470J5	50V 47P
R952, 953	ERDS2TJ102	1/4W 1K	C128	ECBT1H102KB5	50V 1000P	C346	ECEA1HKA0R1B	50V 0. 1U
R954	ERDS2TJ101	1/4W 100	C129, 130	ECEA0JKA101B	6. 3V 100U	C347	ECEA1CN100SB	16V 10U
R955	ERDS2TJ824	1/4W 820K	C132	ECBT1H102KB5	50V 1000P	C348	ECEA1CKA330B	16V 33U
R956	ERDS2TJ101	1/4W 100	C133, 134	ECBT1H270JU5	50V 27P	C349	RCE1HKA3R3BG	50V 3. 3U
R957	ERDS2TJ102	1/4W 1K	C135, 136	ECBT1C103KS5	16V 0. 01U	C350	ECEA0JKA470B	6. 3V 47U
R958	ERDS2TJ471	1/4W 470	C137, 138	ECBT1H561KB5	50V 560P	C351, 352	RCE1CKA100BG	16V 10U
R959	ERDS2TJ103	1/4W 10K	C139, 140	ECBT1C682KR5	16V 6800P	C353, 354	ECBT1H101KB5	50V 100P
R960	ERDS2TJ472	1/4W 4. 7K	C141-144	ECEA1HKA010B	50V 1U	C355	ECEA1CKA330B	16V 33U
R961	ERDS2TJ103	1/4W 10K	C145	ECBT1H220JC5	50V 22P	C356	ECBT1H104ZF5	50V 0. 1U
R962	ERDS2TJ473	1/4W 47K	C148	ECBT1C103NS5	16V 0. 01U	C357	RCE1CM101BV	16V 100U
R963	ERDS2TJ472	1/4W 4. 7K	C149	ECBT1H104ZF5	50V 0. 1U	C361, 362	ECBT1H221KB5	50V 220P
R964	ERDS2TJ332	1/4W 3. 3K	C171, 172	ECBT1H102KB5	50V 1000P	C365	ECEA0JKA470B	6. 3V 47U

Ref. No.	Part No.	Values & Remarks
C391, 392	RCE1CM101BV	16V 100U
C393, 394	ECBT1H102KB5	50V 1000P
C453	ECEA1HKA010B	50V 1U
C455	RCE1CKA100BG	16V 10U
C509	ECBT1E103ZF	25V 0.01U
C510	RCE1AKA101BG	10V 100U
C601, 602	ECKT1H223ZF	50V 0.022U
C603 △	ECA1EM102B	25V 1000U
C604 △	RCE1EM471BV	25V 470U
C605, 606	ECBT1E103ZF	25V 0.01U
C607	RCE1CKA100BG	16V 10U
C608	RCE1CM101BV	16V 100U
C609	ECBT1H102KB5	50V 1000P
C610, 611	ECBT1H104ZF5	50V 0.1U
C612	RCE1EM471BV	25V 470U
C613	ECBT1E103ZF	25V 0.01U
C614	RCE1CKA100BG	16V 10U
C615	ECEA1EKA101B	25V 100U
C616	ECA1M470B	50V 47U
617△	ECA1M470B	50V 47U
C618	ECA1JM470B	63V 47U
C619	ECBT1E103ZF	25V 0.01U
C620	RCE1VKA100BG	35V 10U
C622	RCE1VKA100BG	35V 10U
C631-636	ECBT1H101KB5	50V 100P
C637	ECBT1H102KB5	50V 1000P
C638	ECBT1H101KB5	50V 100P
C651, 652	ECBT1H104ZF5	50V 0.1U
C653, 654	ECBT1H102KB5	50V 1000P
C655	ECQV1H224JM3	50V 0.22U
C901-904	ECBT1H471KB5	50V 470P
C905, 906	ECBT1H102KB5	50V 1000P
C907	ECBT1H104ZF5	50V 0.1U
C908	ECBT1E103ZF	25V 0.01U
C909	ECEA1HKA2R2B	50V 2.2U
C910	RCE1CKA100BG	16V 10U
C911	ECBT1H270JU5	50V 27P
C912	ECBT1H220GC5	50V 22P
C913	ECBT1H104ZF5	50V 0.1U
C915	ECBT1E103ZF	25V 0.01U
C916, 917	ECEA1HKA010B	50V 1U
C918	ECBT1H104ZF5	50V 0.1U
C919	RCE0JU102BV	6.3V 1000U
C920	ECBT1E103ZF	25V 0.01U
C921	ECA0JKF101B	6.3V 100U
C923	ECEAOJKA221B	6.3V 220U
C924-926	ECBT1H102KB5	50V 1000P
C927	ECBT1C105ZF5	16V 1U

Ref. No.	Part No.	Part Name & Description	Remarks
		CABINET PARTS	
1	RKM0302-K	TOP CABINET	
2	RHD30007-K1	SCREW	
3	XTB3+8JFZ	SCREW	
4	RGR0216A-N	REAR PANEL	
5	RFKJTV910-K	BOTTOM CHASSIS ASS'Y	
5-1	RKA0011-3	FOOT	
7	RMNO195	SPACER	
8	RMNO319	FL HOLDER	
9	RFKGTCH540EK	FRONT PANEL ASS'Y	(E)
9	RFKGTCH540EG	FRONT PANEL ASS'Y	(EG)
9-1	RKW0466-Y1	PANEL	(E)
9-1	RKW0466A-Y1	PANEL	(EG)
10	RGL0284-Q	PANEL LIGHT	
11	REZ0777	FFC (20P)	
12	XTB3+16JFZ	SCREW	
13	XTB3+8J	SCREW	
14	SHE185-2	SPACER	
15	RHD30070	GND SCREW	
16	XTB3+8JFZ1	SCREW	
17	RFKNTCH530EA	BUTTON, SELECTOR	
18	RFKNTCH530EB	BUTTON, BAND	
19	RFKNTCH530EC	BUTTON, MULTI	
20	RMNO337	HOLDER	

Cabinet Parts Location

1129

