

Service Manual

Tuner/Sound Processor

Tuner

ST-CH570

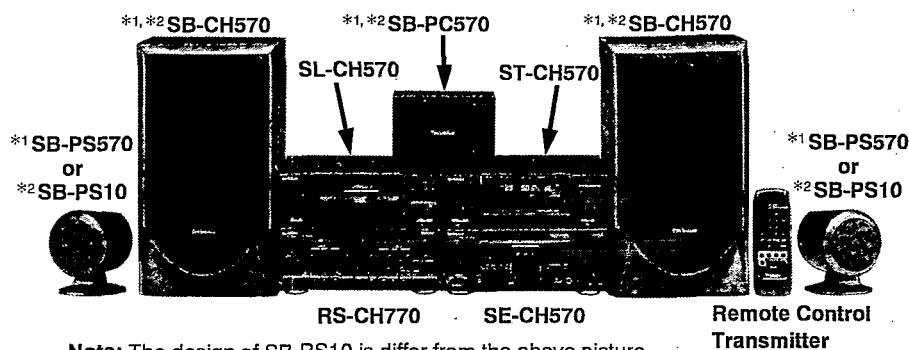
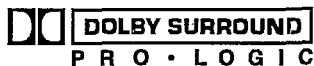

Colour
(K) : Black

Areas

Suffix for Model No.	Area	Colour
(E)	Europe	(K)
(EG)	Germany and Italy	
(GC)	Asia, Latin America, Middle East, Africa and Oceania	

Note: The design of SB-PS10 is differ from the above picture.

Because of unique interconnecting cables, when a component requires service, send or bring in the entire system.

System: SC-CH570

Specifications

- Pre-amplifier section
 - Input sensitivity/impedance [For (E) and (EG) areas] PHONO 2.5 mV/47 kΩ
 - EXTERNAL, AUX 250 mV/15 kΩ
 - Output level EXTERNAL REC OUT 150 mV/1.5 kΩ
 - Frequency response [For (E) and (EG) areas] PHONO 30 Hz – 15 Hz/+1.5 to -2.0 dB
 - EXTERNAL, AUX 20 Hz – 40 kHz
 - S/N [For (E) and (EG) areas] PHONO DIN 73 dB (77 dB, IHF)
 - EXTERNAL, AUX DIN 80 dB, (82 dB, IHF)
- EQ/SFP section
 - Center frequency 120 kHz, 1 kHz, 7 kHz
 - EQ SPACE mode 3 modes HALL, CLEAR, HEAVY
 - V. BASS mode
 - Center frequency 70 Hz
 - V. BASS 1 +3 dB
 - V. BASS 2 +6 dB
- DOLBY PRO LOGIC section
 - PRO LOGIC mode SURROUND, 3 STEREO
 - CENTER mode NORMAL, WIDE, PHANTOM
 - DELAY TIME 20 ms (Fixed)
- FM tuner section
 - Frequency range 87.50 – 108.00 MHz (0.05 MHz steps)
 - Sensitivity 1.8 μV (IHF usable)
 - S/N 26 dB 1.5 μV

- S/N MONO 70 dB (75 dB, IHF)
- Stereo separation 1 kHz 35 dB
- Antenna terminal(s) 75 Ω (unbalanced)
- AM tuner section
 - Frequency range [For (E) area] MW 522 – 1611 kHz (9 kHz steps)
 - 530 – 1620 kHz (10 kHz steps)
 - LW 144 – 288 kHz (9 kHz steps)
 - [For (EG) and (GC) areas] AM 522 – 1611 kHz (9 kHz steps)
 - 530 – 1620 kHz (10 kHz steps)
- Sensitivity (S/N 20 dB) [For (E) area] MW 500 μV/m
- LW 50 μV
- [For (EG) and (GC) areas] AM 500 μV/m
- Timer section
 - Clock Quartz-lock type
 - Function 24-hour programmable; Play timer (1 time), REC timer (1 time), Sleep (120 min, 30 min intervals)
 - 1 minute-23 hours 50 minutes (1 min intervals)
- Setting
- General
 - Dimensions (W x H x D) 270 x 89 x 282 mm
 - Weight 1.7 kg

Note: Specifications are subject to change without notice. Weight and dimensions are approximate.

System	Tuner/sound processor	Compact disc player	Amplifier	Cassette deck	Front speakers	Center speaker	Surround speakers
SC-CH570	ST-CH570	SL-CH570	SE-CH570	RS-CH770	*1,*2SB-CH570	*1 SB-PT570	
						*1 SB-PC570	*1 SB-PS570
						*2 SB-PT570A	
						*2 SB-PC570	*2 SB-PS10

*1 For (E) and (EG) areas: Made in PAES
*2 For (GC) area: Made in NABEL

WARNING

This service information is designed for experienced repair technicians only and is not designed for use by the general public. It does not contain warnings or cautions to advise non-technical individuals of potential dangers in attempting to service a product. Products powered by electricity should be serviced or repaired only by experienced professional technicians. Any attempt to service or repair the product or products dealt with in this service information by anyone else could result in serious injury or death.

Technics®

© 1996 Matsushita Electric Industrial Co., Ltd. All rights reserved. Unauthorized copying and distribution is a violation of law.

Contents

	Page		Page
Location of Controls	2	Schematic Diagram	9 ~ 26
Setting the Time	2, 3	Printed Circuit Board Diagram	27 ~ 30
Enjoying RDS Broadcast [For (EG) area]	3, 4	Wiring Connection Diagram	31
About the Self-Diagnostic Mode	5	Block Diagram	32 ~ 37
Operation Check and		Function of IC Terminals	38, 39
Main Component Replacement Procedures	6	Replacement Parts List	40 ~ 45
To Supply Power Source	7	Cabinet Parts Location	46
Measurements and Adjustments [For (EG) area]	8		

NOTE:

Refer to the service manual for Model No. SE-CH570 (ORDER No. AD9603054C8) for information on "Accessories", "Installation", "Connections" and "Packaging".

Location of Controls

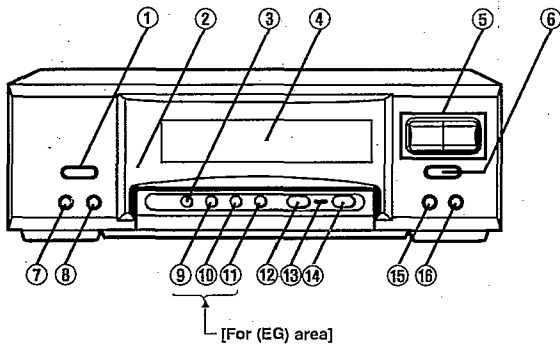

- ① Source input select button (SELECTOR)
- ② Remote control signal sensor (SENSOR)
- ③ Karaoke mode select button (KARAOKE)
- ④ Display
- ⑤ Tuning/timer select button (TUNING/TIMER)
- ⑥ Set button (SET)
- ⑦ Record timer button (Ⓜ REC)
- ⑧ Play timer button (Ⓜ PLAY)
- ⑨ Display mode select button (DISP MODE)...for (EG) area
- ⑩ PTY select button (PTY)...for (EG) area
- ⑪ PTY search button (PTY SEARCH)...for (EG) area
- ⑫ FM/FM mode select button (FM, -AUTO/MONO)
- ⑬ Tuner indicator (TUNER)
- ⑭ LW/MW select button...for (E) area
AM button...for (EG) and (GC) areas
- ⑮ Tuning mode select button (TUNING MODE)
- ⑯ Clock/timer button (CLOCK/TIMER)

Setting the Time

This is a 24-hours display clock.
These instructions explain how to set the timer for 16:25 (4:25 p.m.) on Wednesday.

1

POWER
STANDBY

2

① CLOCK/TIMER ② SET

3

① TUNING/TIMER ② SET

4

① TUNING/TIMER ② SET

5

① TUNING/TIMER ② SET

- 1 Switch on the power.
- 2 ① Press **CLOCK/TIMER** to show "CLOCK".
Within 8 seconds:
② Press **SET**.
- 3 ① Press **TUNING/TIMER** (∨ or ∧) to select the day.
② Press **SET**.
- 4 ① Press **TUNING/TIMER** (∨ or ∧) to select the hour.
② Press **SET**.
- 5 ① Press **TUNING/TIMER** (∨ or ∧) to select the minutes.
② Press **SET** to finish setting the time.

The display will return to the previous display after about 3 seconds.

When "SUN 0:00" flashes:

It flashes when you connect the AC power supply cord for the first time or if there has been a power failure.
If this happens, reset the time.

If the minutes setting has gone wrong:

1. Press **CLOCK/TIMER**.
2. Press **SET** 3 times.
3. Press **TUNING/TIMER** (∨ or ∧) to set the minute, and then press **SET**.

To display the clock again:

Press **CLOCK/TIMER**.
The clock display will appear for about 8 seconds.

For your reference:

When you turn OFF the power from the **POWER** button, the stereo goes on standby and the **STANDBY** lamp lights up.

■ Enjoying RDS Broadcast [For (EG) area]

For extra tuning convenience, the SC-CH570 let you take advantage of the Radio Data System (RDS) in areas where RDS broadcast services are received. This advanced system simplifies operation and provides useful information, utilizing a 57 kHz subcarrier above the audible range, in addition to the main FM signal.

What is RDS (Radio Data System)?

RDS is a multiplex broadcasting system which adds a variety of message signals to the audio signals of FM broadcasts. This system can utilize the following signals among the various RDS signals.

RDS messages used by this system:

- PS (Program service name): Name of the broadcast station
- PTY (Program type): Identification signal for program types such as news and sport

Note

"PTY" may not be available in some areas. (Future function)

Functions of this system which use RDS

To display the name of a broadcast station (PS display):

When this system receives a PS signal in an RDS broadcast, the name of the broadcast station is shown on the display.

To search for a program of a particular type, such as news or sport (PTY search):

When you wish to listen to a particular type of program, a program of that type can be searched.
Furthermore, while the PTY signal is being received, the name of the type of program currently being broadcast can be shown on the display.

Note

Even if an FM broadcast station is transmitting RDS signals, the functions of this system may not be able to utilize these signals if the signal quality is too poor.

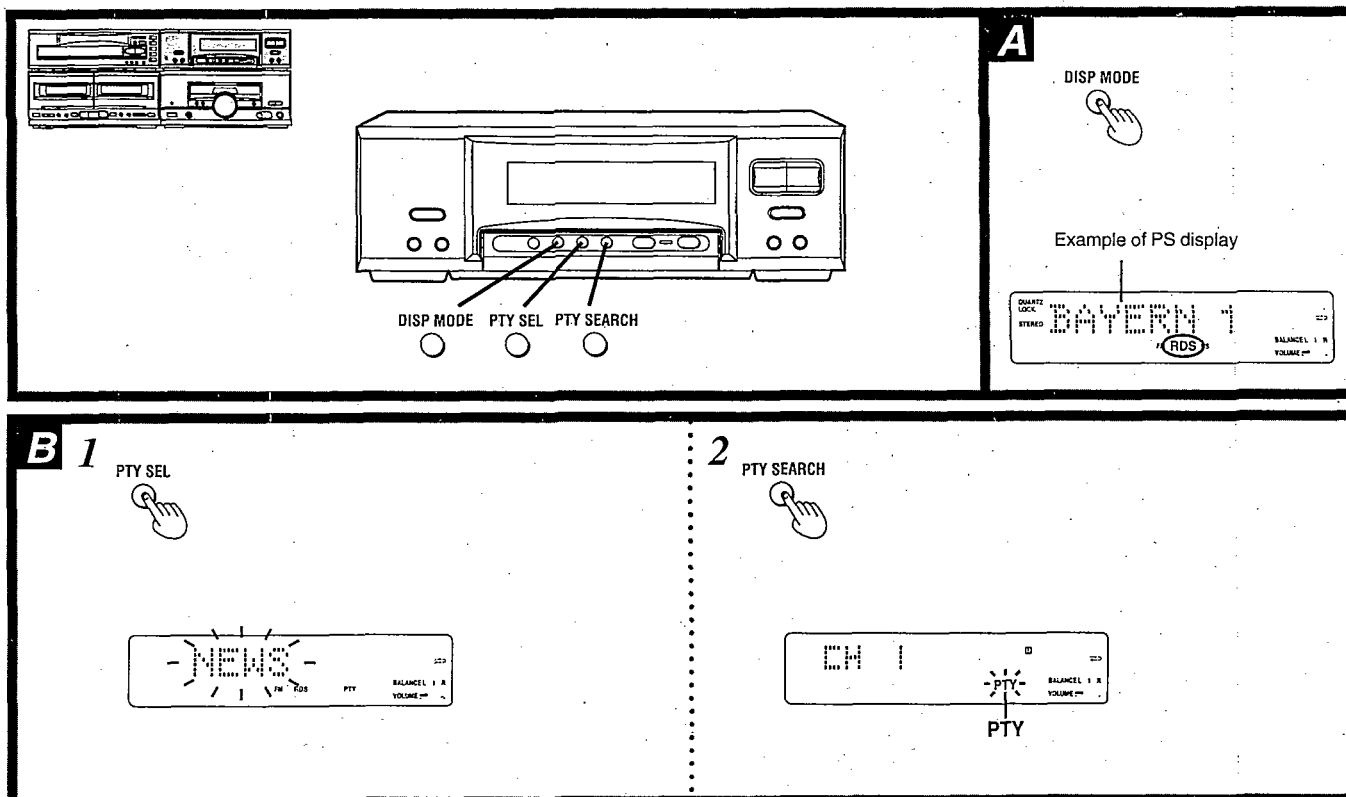

To display the name of a broadcasting station

(When the FM station is received)

Press **DISP MODE**.

If the FM broadcast being received provides the RDS service ("RDS" indicator will light), the name of the broadcast station and "PS" indicator will be shown on the display of this system.

Each time you press the button, the display will change as follows.

Frequency display → PS display → PTY display

Note

- If the FM broadcast being received does not provide the RDS service, "NO RDS" will be displayed when PS display mode or PTY display mode is selected.
- If a PTY signal is not being received, "NO PTY" will be displayed when the PTY display mode is selected.
- When receiving a broadcast station, in PTY mode, which does not transmit PTY, the display will not show "NO PTY" automatically. The same also applies to "NO RDS" when RDS is not transmitted.

When the desired type of program is located:

The type of program is displayed for approximately 5 seconds and the program will automatically change to the broadcast station that has just been located.

To search for a different broadcast station, press the PTY SEARCH once more while the type of program is displayed.

About the PTY display

There are a total of 15 PTY displays on this unit. The display changes in order each time the PTY SEL is pressed. The table shows the order in which the display changes, and also gives an explanation of each display.

Display	Explanation
NEWS	Short accounts of facts, events and publicly expressed views, reportage and actuality.
AFFAIRS	Topical program expanding or enlarging upon the news, generally in different presentation style or concept, including documentary debate, or analysis.
INFO	Program whose purpose is to impart advice in the widest sense, including meteorological reports and forecasts, consumer affairs, medical help, etc.
SPORT	Program concerned with any aspect of sport.
EDUCATE	Program intended primarily to educate.
DRAMA	All radio plays and serials.
CULTURE	Programs concerned with any aspect of national or regional culture, including religious affairs, philosophy, social science, language, theatre, etc.
SCIENCE	Programs about the natural sciences and technology.
VARIED	Used for mainly speech-based programs, usually of a light-entertainment nature not covered by above categories. Examples are: quizzes, panel games, personality interviews, comedy and satire.

To listen to a program of a particular type, such as news or sport (PTY search)

- The PTY search is carried out with respect to FM broadcast stations that have been preset into the memory. Make sure that "Memory Presetting" have been completed before carrying out PTY search.
- Carry out this operation while tuning in an FM broadcast.

Note

"PTY" may not be available in some areas. (Future function)

1 Press PTY SEL to select the desired program type.

Each time you press this button, the PTY display will change in sequence.

2 While PTY display is flashing (approx. 8 seconds)

Press **PTY SEARCH**.

The PTY search will begin. ("PTY" will flash on the display.)

If the desired type of program is not found:

"NO PTY" will be displayed for approximately 5 seconds, and the program will return to the previous broadcast station.

Most-recent memory:

The most-recent memory system "remembers" the program type last selected when the unit was switched OFF. For example, if "SPORT" is selected and the system is turned OFF, when the PTY SEL is pressed again, "SPORT" will be displayed.

Display	Explanation
POP M	Commercial music which would generally be considered to be of current popular appeal, often featuring in current or recent record sales charts.
ROCK M	Contemporary modern music, usually written and performed by young musicians.
M.O.R. M	(Middle of the Road Music). Common term to describe music considered to be "easy-listening", as opposed to Pop, Rock or Classical. Music in this category is often, but not always, vocal, and usually of short duration (<5 min.).
LIGHT M	Classical Musical for general, rather than specialist, appreciation. Examples of music in this category are instrumental music and vocal or choral works.
CLASSICS	Performances of major orchestral works, symphonies, chamber music etc., and including Grand Opera.
OTHER M	Musical styles not fitting into any of the above categories. Particularly used for specialist music, of which Jazz, Rhythm & Blues, Folk, Country, and Reggae are examples.

After "OTHER M" is displayed, the display returns to "NEWS".

■ About the Self-Diagnostic Mode

This unit is equipped with a self-diagnostic function which, in the event of a malfunction, automatically displays a code indicating the nature of the malfunction. Use this self-diagnostic function when servicing the unit.

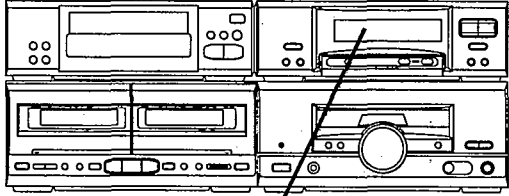
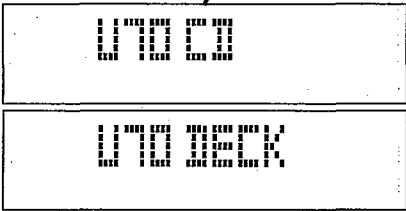
Display method	Display location
<p>To display the malfunction code</p> <p>U-70 CD: U-70 DECK: ... Automatically displays on the tuner/sound processor when a malfunction occurs.</p> <p>F-61 Automatically displays on the tuner/sound processor when a malfunction occurs.</p> <p>To return to the normal display</p> <p>1. For U-70 CD/U-70 DECK:</p> <ul style="list-style-type: none"> ● Press any operation button on the tuner/sound processor. ● To re-display the code, switch the power off (POWER STANDBY button), and then switch power back on again. <p>2. For F-61:</p> <ul style="list-style-type: none"> ● If "F-61" is displayed, the power will automatically be switched off and the standby indicator will light up. ● "F-61" will be displayed for 3 seconds, and then the clock will be displayed. ● To re-display the code, switch the power on. "F-61" will be re-displayed, and then after 3 seconds the clock will be displayed and the power will automatically switch off. 	<p>CD player (SL-CH570) Tuner/sound processor (ST-CT570)</p>  <p>Cassette deck (RS-CH770) Amplifier (SE-CH570)</p> 

Display contents

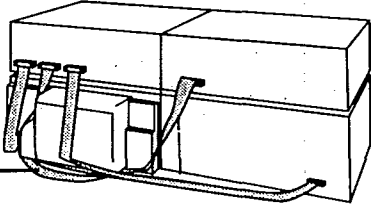
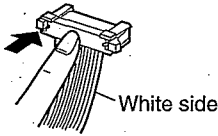
Display code	Problem or condition	Correction procedure
<p>U-70 CD U-70 DECK (displayed automatically)</p>	<p>A bus-line communications error has occurred as a result of the flat cables being inserted incorrectly, thus preventing the system from operating.</p> <p>1. If "U-70" is displayed on the tuner/sound processor, the tape deck or CD Changer cannot be operated by remote control.</p>	<p>Correction procedure</p>  <p>Flat cable</p> <ol style="list-style-type: none"> To check for correct insertion of the flat cables. <ol style="list-style-type: none"> Insert each connector until you hear a click. Insert the flat cables at the back of the unit in the order indicated. Make sure the white side of the cable is on your right side. Breakage of flat cable. (Check and replace as necessary.) If the problem is not corrected by items (1.) and (2.) above, this indicates a faulty IC. <p>ST-CH570: IC901 (M38197MA132F)</p> <p>SL-CH570: IC403 (LC66356B4G98)</p> <p>RS-CH770: IC701 (M37471M4650F)</p> <p>Check these IC's and replace as necessary.</p>  <p>White side</p>
<p>F-61</p>	<p>When the power switch is switched on, it automatically switches back off, making it impossible to switch power on.</p>	<ul style="list-style-type: none"> ● Faulty amplifier (SE-CH570) output IC (IC501). (When a DC voltage is applied to the speaker terminals.)

Operation Check and Main Component Replacement Procedures

- NOTE**
1. This section describes procedures for checking the operation of the major printed circuit boards and replacing the main components.
 2. For reassembly after operation checks or replacement, reverse the respective procedures. Special reassembly procedures are described only when required.
 3. Illustrated screws are equivalent to actual size.

1. Checking for the tuner P.C.B., dolby pro logic P.C.B. and operation P.C.B.

• Check the tuner P.C.B., dolby pro logic P.C.B. and operation P.C.B. as shown below.

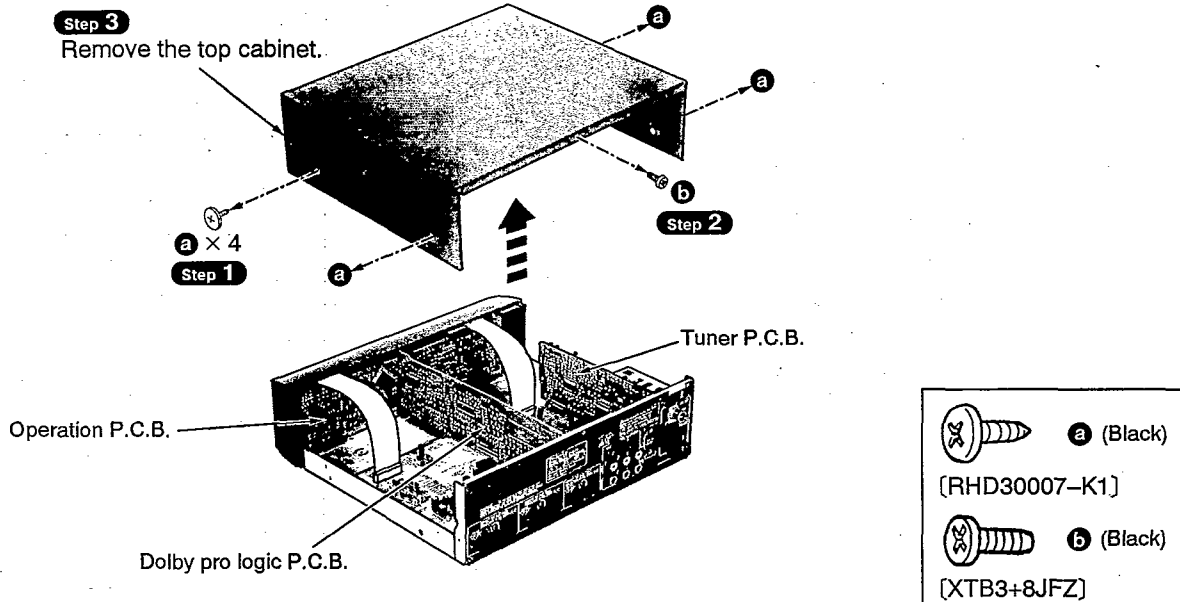

2. Checking for the main P.C.B.

• Check the main P.C.B. as shown below.

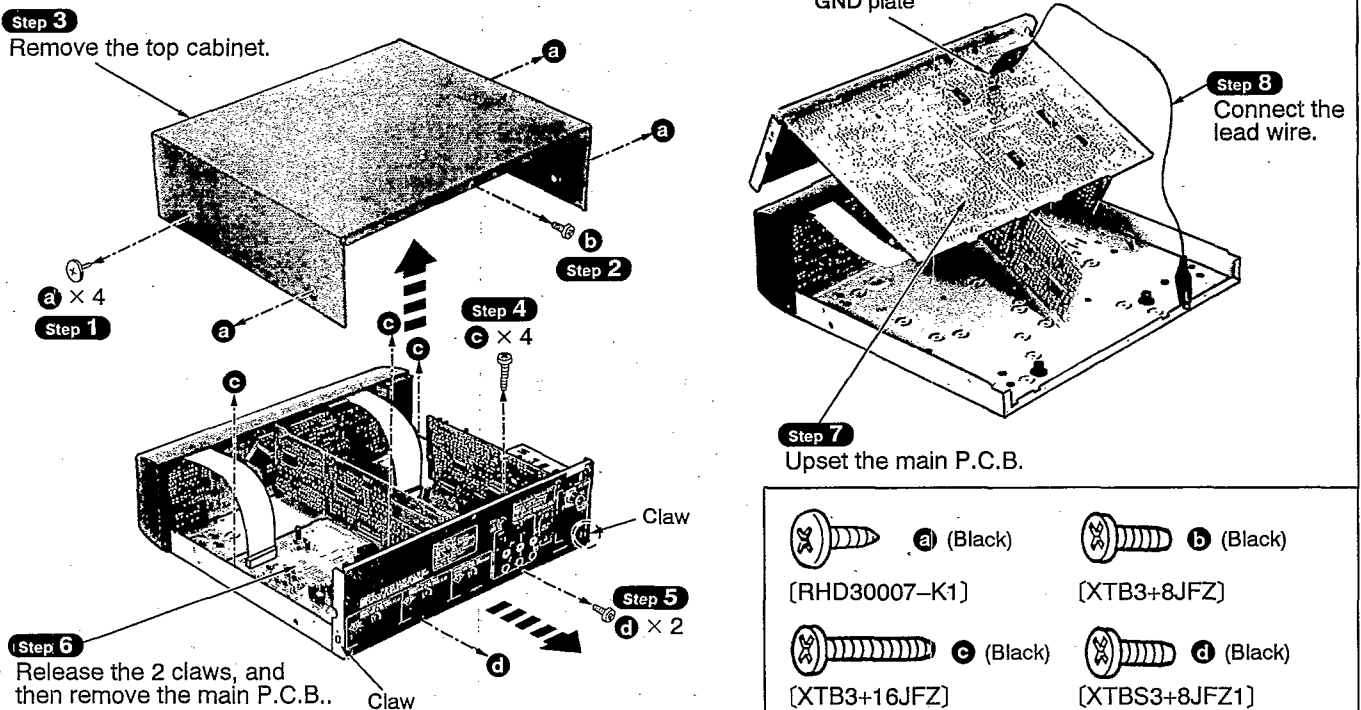

■ To Supply Power Source

This unit ST-CH570 is designed to operate on power supplied from the Amplifier SE-CH570.

When operating the unit ST-CH570 alone for testing and servicing, without having power supplied from the Amplifier SE-CH570, use the following method.

Power Supply to Main Circuit

1. Short the section between the test points **TP602** and **TP610**, and as well as the section between the test points **A.GND** (J611) and **TP610**.
2. Connect the 3V AC power to pin 1 of the indicator module FL901 and the GND terminal to pin 57 of the same FL901 module.
3. Apply 11 V AC power to the section between the point **TP601** (**AC**) and the point **TP602** (**CT**) as well as the section between the point **TP603** (**AC**) and the point **TP602** (**CT**). This unit comes to stand-by mode.
4. Short the section between the jumper **J315** **TP611** and the point **D.GND** of the jumper **J608** **TP610** for a moment. The main circuit comes to power ON mode. (Whenever this operation is performed, power, ON/OFF mode is repeated.)

Power Supply to Tuner Circuit

1. Apply power source to the main circuit.
2. Connect the DC +12 V terminal to the jumper **J610** **TP608**, and the GND terminal to both the point **T.GND** of the jumper **J609** **TP609** and the point **D.GND** of the jumper **J608** **TP610** using the DC power supply tool.

Note: If the GND terminal of the DC power supply tool is connected to the point **D.GND** of the jumper **J608** **TP610**, an error occurs in measurement values for voltage and waveform.

To Check Signals

Connect the oscilloscope or the speaker with the built-in amplifier to the EXTERNAL (OUT) terminals and check if the signals are outputting from this unit.

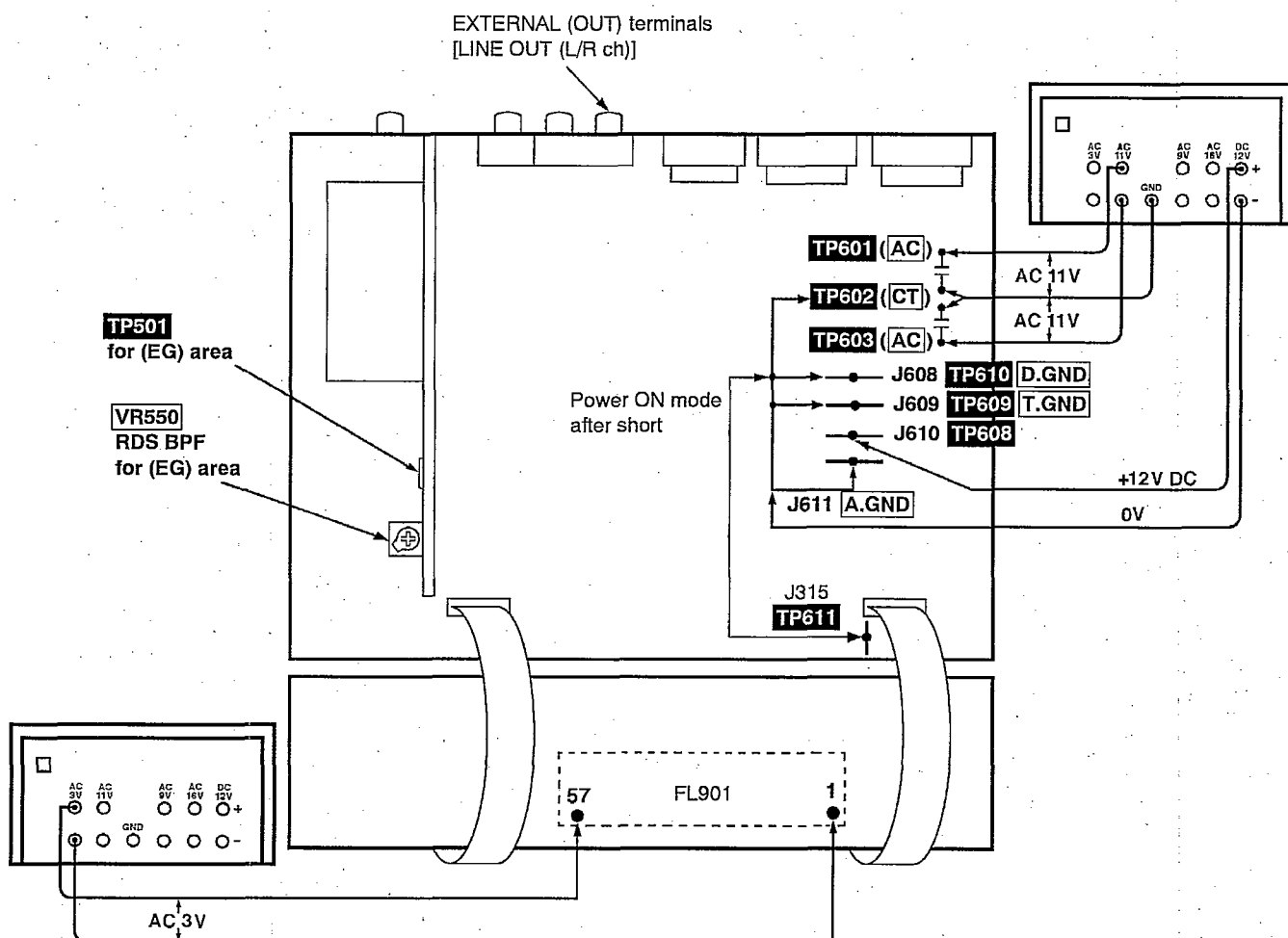

Fig. 1

■ Measurements and Adjustments [For (EG) area]

Measuring Instruments and Special Tools

- FM signal generator (FM-SG)
- RDS modulator
- AC electronic voltmeter (AC EVM) *
(* Min. 0.3 mV measurable)
- 75 Ω coaxial cable

RDS (Radio Data System) BPF Adjustment

1. Test equipment connection is shown in Fig. 2.
2. Set the unit to "FM" mode.
3. Set the radio frequency display and signal generator to **100.10 MHz**.
4. Adjust **VR550** so that the **TP501** output is maximized.

FM Signal Generator Condition

Modulation	100%
Modulation frequency	1 kHz
RDS modulation	2.7%
Output level	60 dB

How to make simple adjustment without using a RDS modulator

1. Tuner into a FM broadcast with a RDS signal transmitted from a FM station whose electric field intensity is more than 50 dB.
2. Adjust **VR550** so that the **TP501** output is maximized.

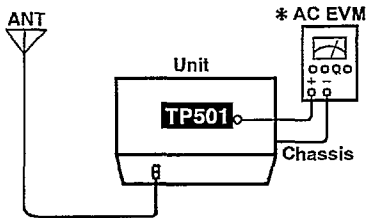

Fig. 3

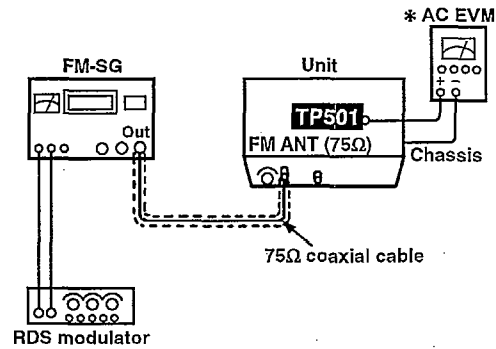

Fig. 2

Note: * Use the voltmeter measurable up to 0.3 mV at the minimum.

● What is RDS (Radio Data System)?

RDS is a multiplex broadcasting system which adds a variety of message signal to the audio signals of FM broadcasts. This unit can utilize the following signals among the various RDS signals.

RDS messages used by this unit

- PS (Program service name)
Name of the broadcast station
- PTY (Program type)
Identification signal for program types such as news and sport

Note

"PTY" may not be available in some areas.

■ Schematic Diagram

	Page
A TUNER CIRCUIT For (E) area	10, 11
A TUNER CIRCUIT For (GC) area	12, 13
A TUNER CIRCUIT For (EG) area	14 ~ 16
C MAIN CIRCUIT	17 ~ 21
B OPERATION CIRCUIT	22, 23
D DOLBY PROLOGIC CIRCUIT For (E) and (EG) areas	24 ~ 26

- This schematic diagram may be modified at any time with the development of new technology.

Notes:

- **S901**: FM switch (FM)
- **S902**: LW/MW select switch (LW/MW)... for (E) area
AM switch (AM)... for (EG) and (GC) areas
- **S903**: Tuning mode select switch (TUNING MODE)
- **S904**: Timer/clock switch (TIMER/CLOCK)
- **S905**: Set switch (SET)
- **S906**: Tuning/timer select switch (TUNING/TIMER V)
- **S907**: Tuning/timer select switch (TUNING/TIMER ^)
- **S911**: PTY search switch (PTY SEARCH)... for (EG) area
- **S912**: PTY selector switch (PTY SEL)... for (EG) area
- **S913**: Display mode selector switch (DISP MODE)... for (EG) area
- **S915**: Karaoke mode select switch (KARAOKE)
- **S916**: Play timer switch (⊕ PLAY)
- **S917**: Record timer switch (⊖ REC)
- **S918**: Source input select switch (SELECTOR)
- Indicated voltage values are the standard values for the unit measured by the DC electronic circuit tester (high-impedance) with the chassis taken as standard. Therefore, there may exist some errors in the voltage values, depending on the internal impedance of the DC circuit tester.
- Voltage values and waveforms are measured as indicated in the schematic diagram when test points between **TP602** and **TP610** and between **TP610** and **A.GND** are shorted.











No mark : FM mode () : AM (MW) mode < > : AM (LW) mode

- Important safety notice:
Components identified by  mark have special characteristics important for safety. Furthermore, special parts which have purposes of fire-retardant (resistors), high-quality sound (capacitors), low-noise (resistors), etc. are used. When replacing any of components, be sure to use only manufacturer's specified parts shown in the parts list.

• Caution!





- IC and LSI are sensitive to static electricity.
Secondary trouble can be prevented by taking care during repair.
Cover the parts boxes made of plastics with aluminum foil.
Ground the soldering iron.
Put a conductive mat on the work table.
Do not touch the legs of IC or LSI with the fingers directly.

• Voltage and signal line

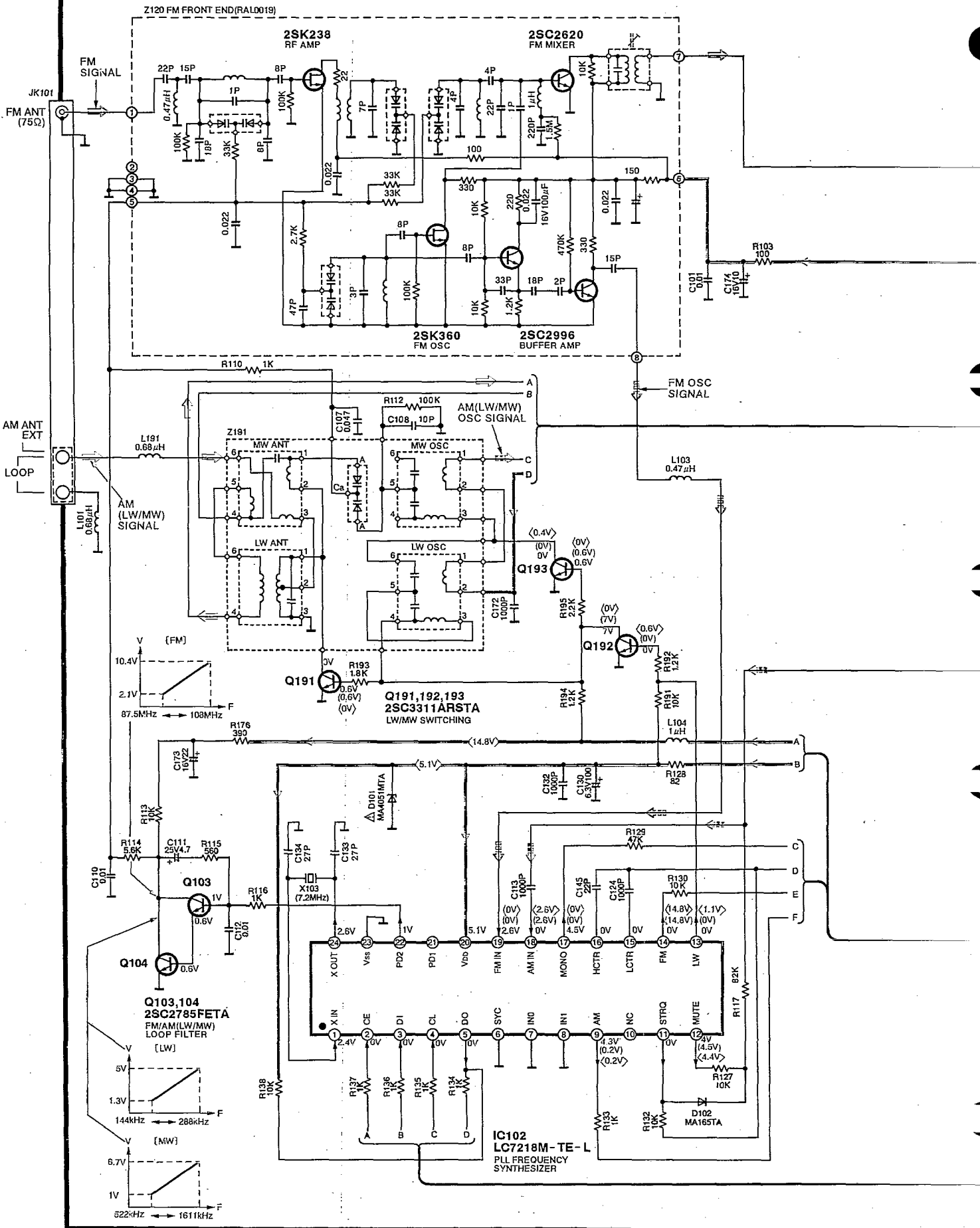

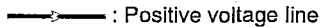

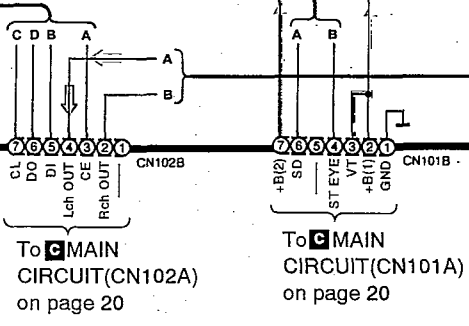
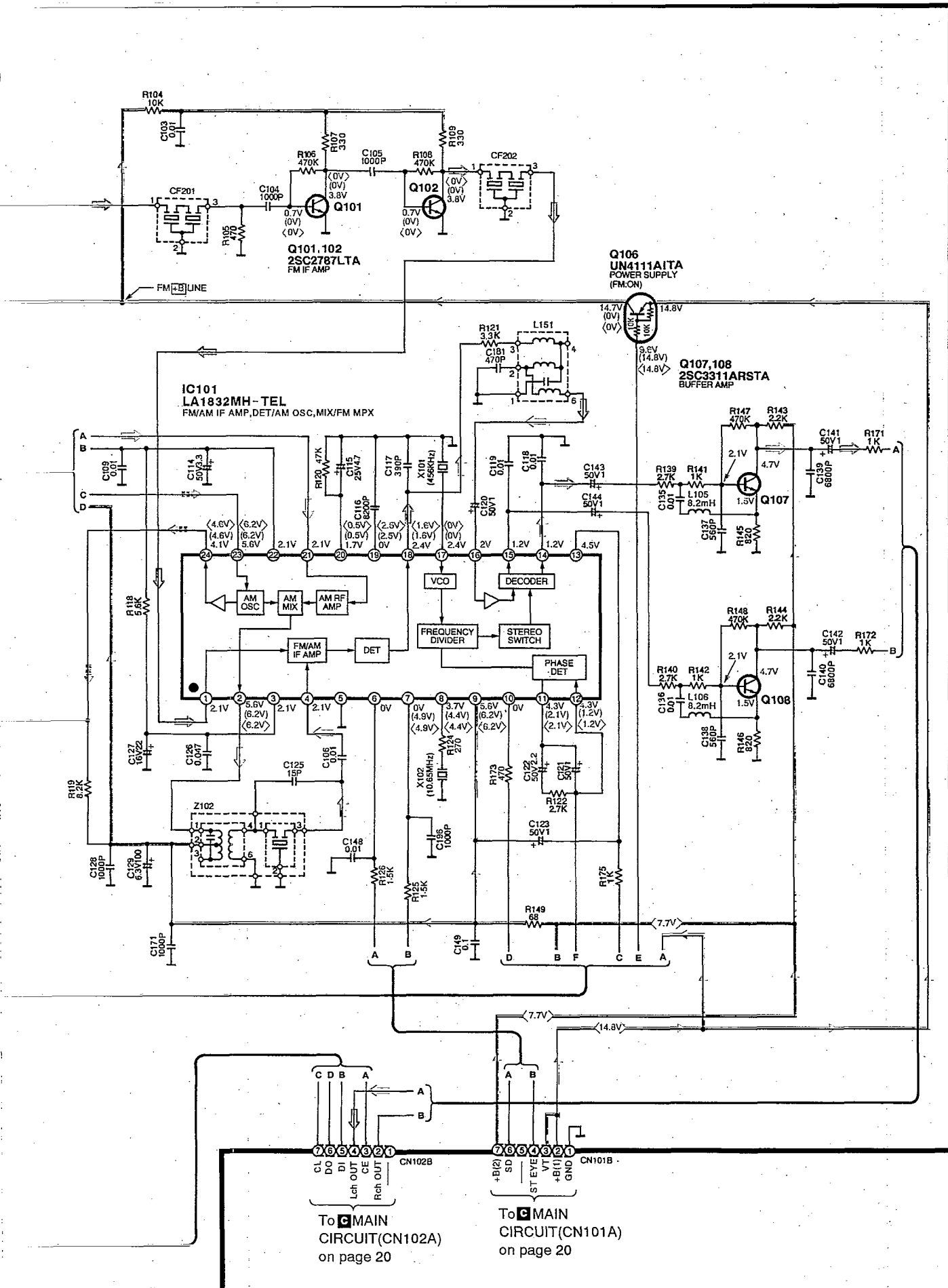

	: Positive voltage line		: Negative voltage line
	: FM signal line		: FM OSC signal line
	: AM (LW/MW) signal line		: AM (LW/MW) OSC signal line
	: REC OUT signal line		: MIC signal line
	: Center speaker drive signal line		
	: Surround speaker drive signal line		

A TUNER CIRCUIT For [E] area. (P.C. Board: on page 27)



 : Positive voltage line
  : FM signal line
  : FM OSC signal line
 : AM (LW/MW) signal line
  : AM (LW/MW) OSC signal line



 : Positive voltage line
 : AM signal line
 : FM signal line
 : AM OSC signal line
 : FM OSC signal line
 : AM OSC signal line

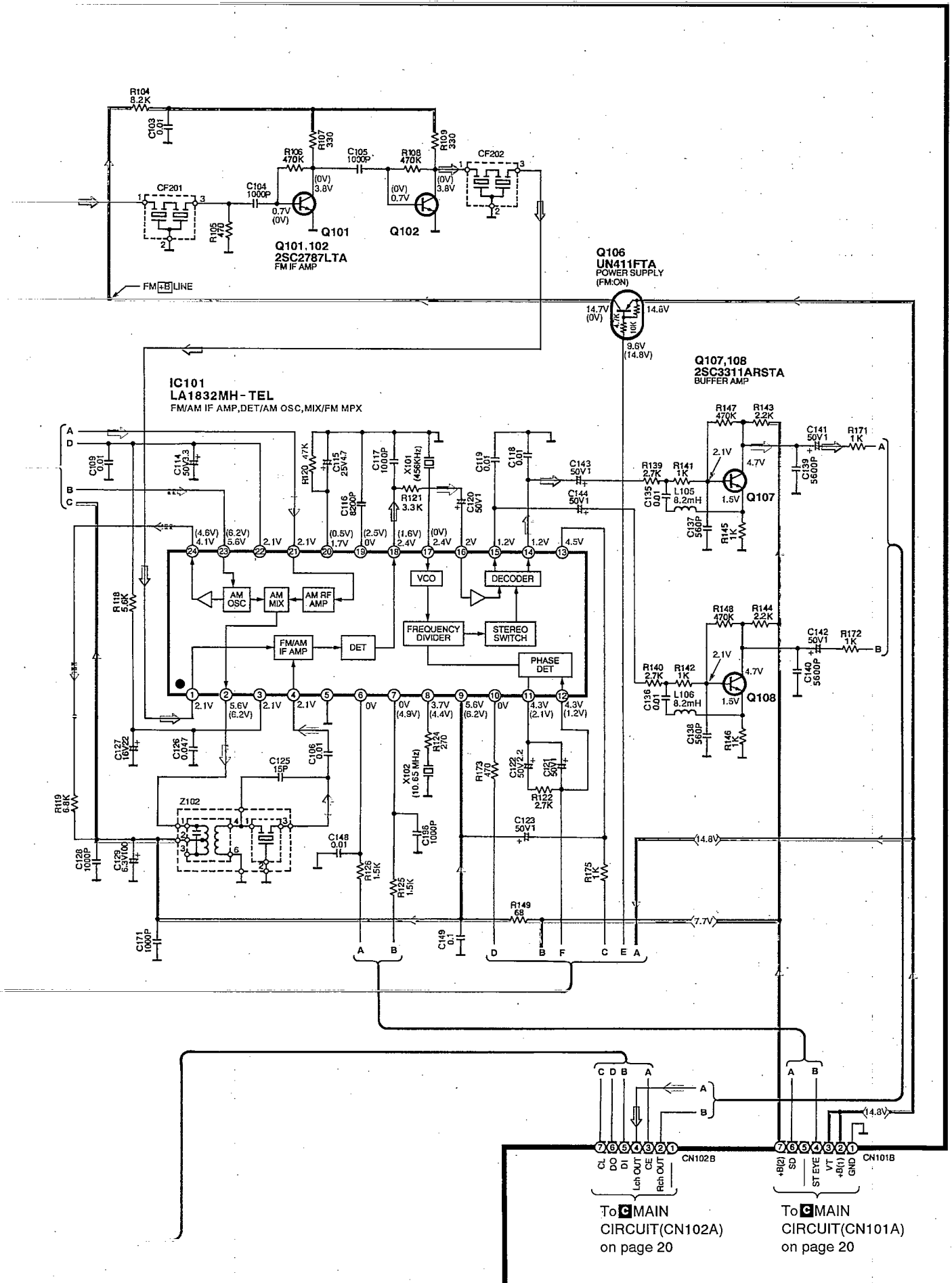

A TUNER CIRCUIT For [EG] area. (P.C. Board: on page 27)

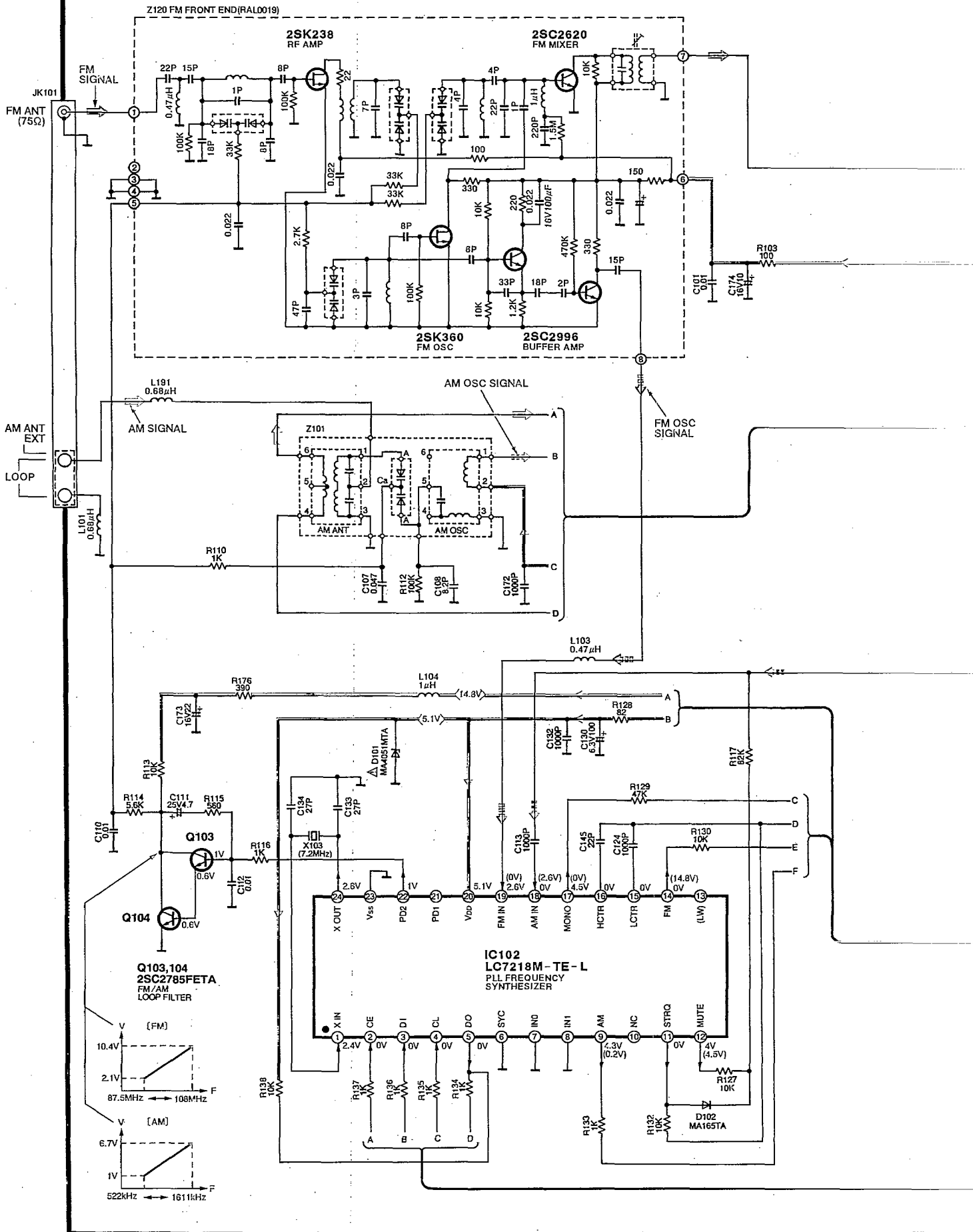

: Positive voltage line
 : AM signal line
 : FM signal line
 : FM OSC signal line
 : AM OSC signal line

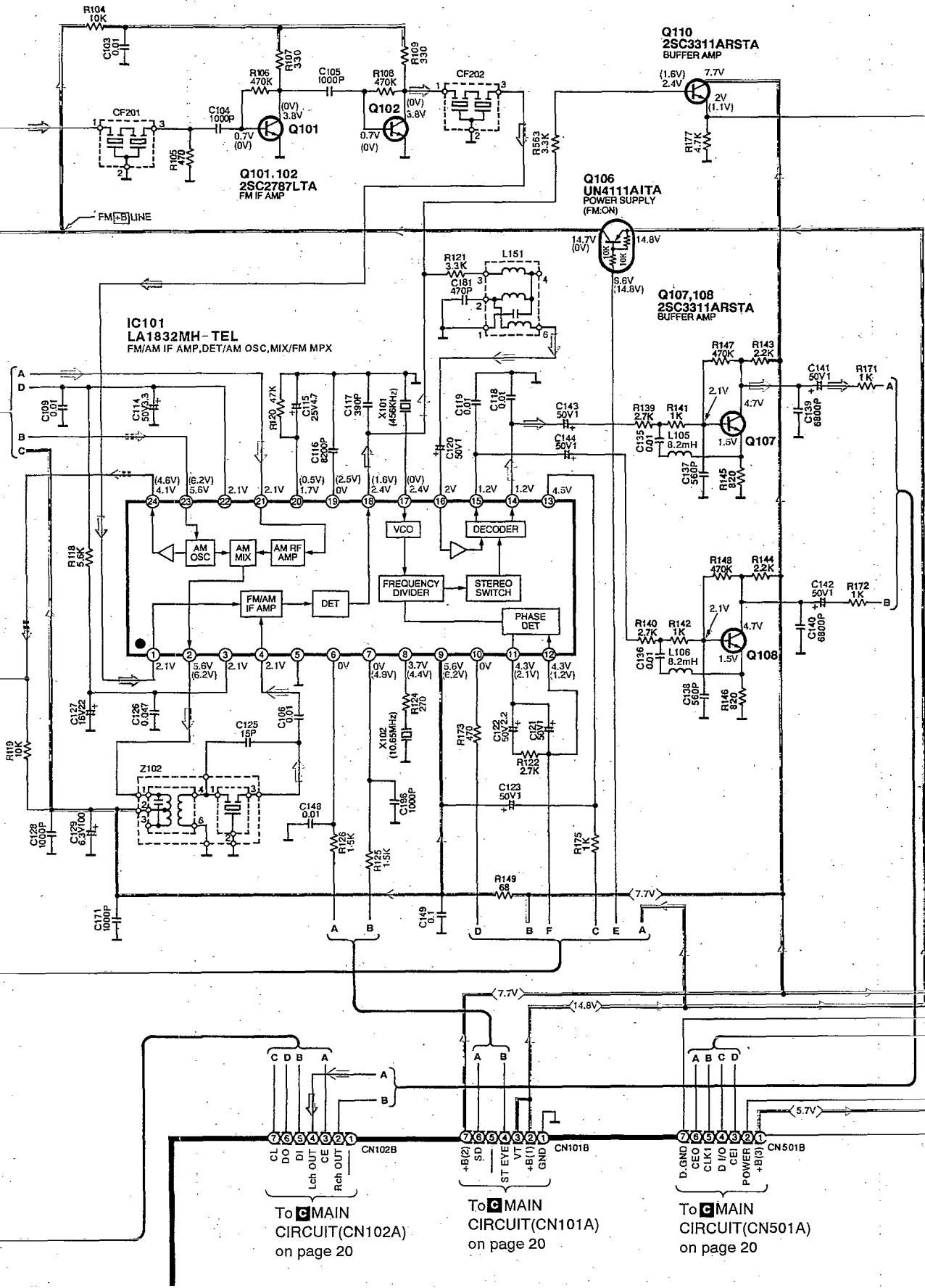

A TUNER CIRCUIT For [EG] area. (P.C.Board: on page 27)

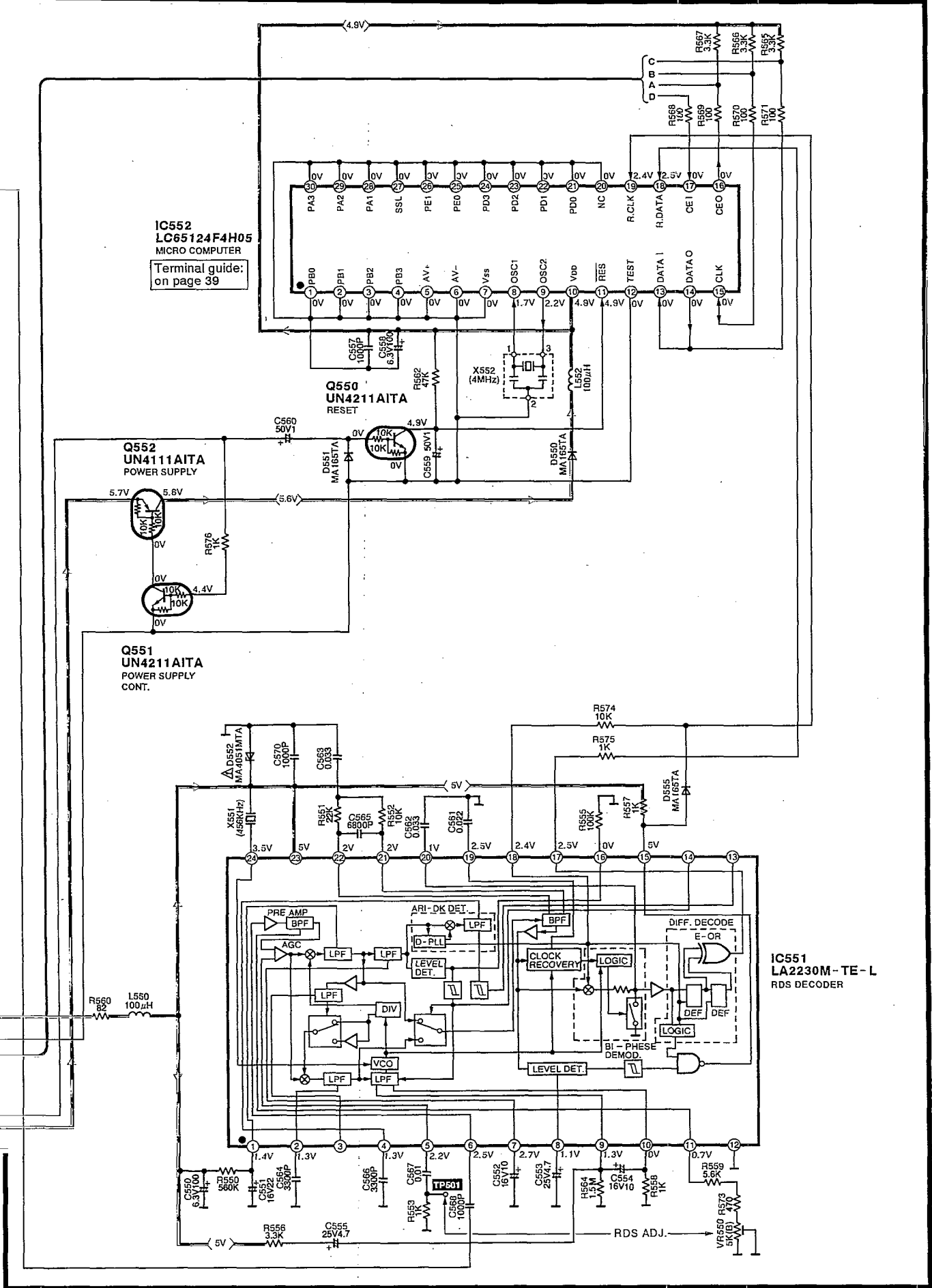

→ : FM signal line
 → : Center speaker drive signal line

→ : AM signal line
 ⇄ : Surround speaker drive signal line.

C MAIN CIRCUIT (P.C.Board: on page 29)

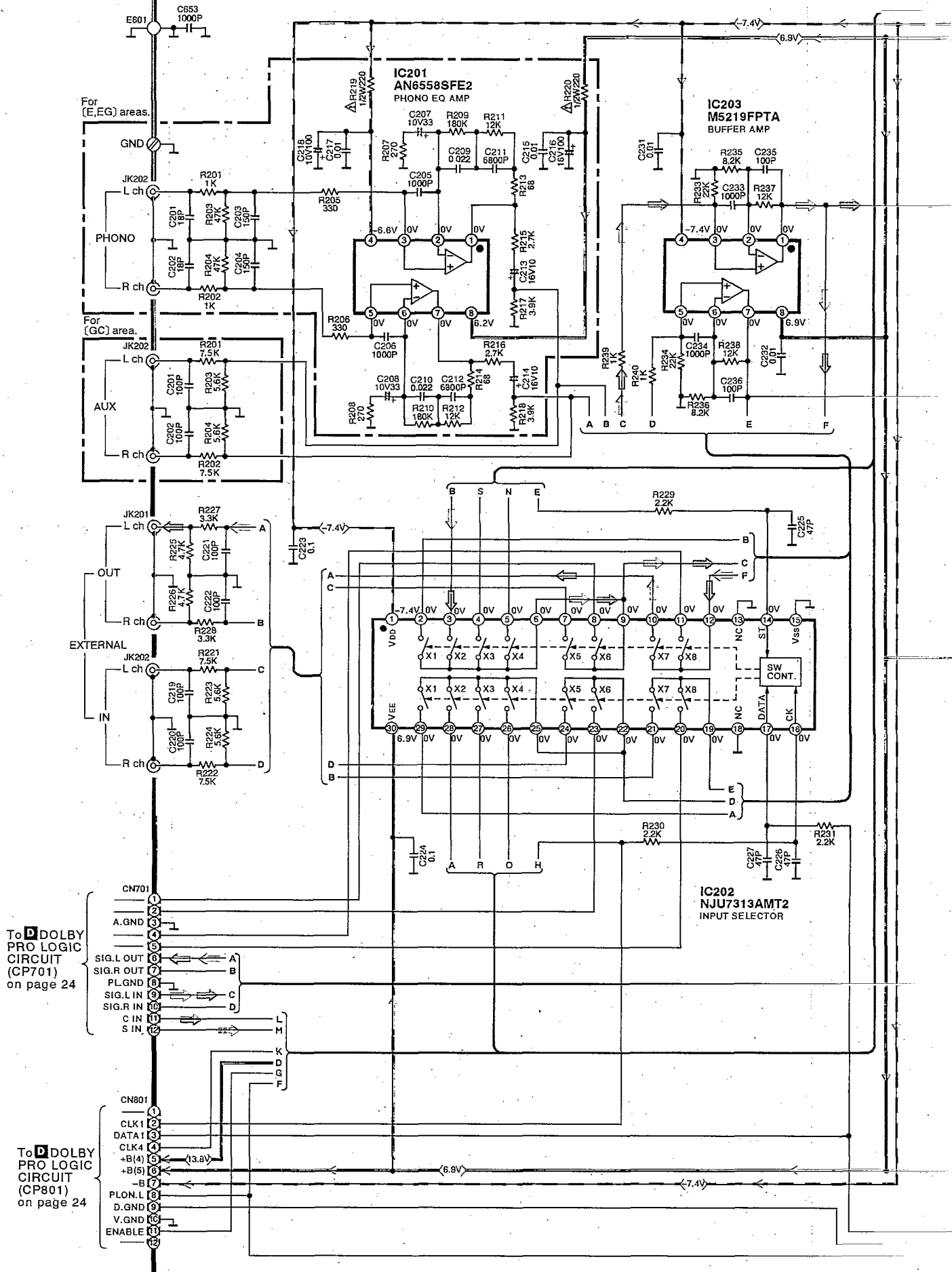

C MAIN CIRCUIT (P.C.Board: on page 29)

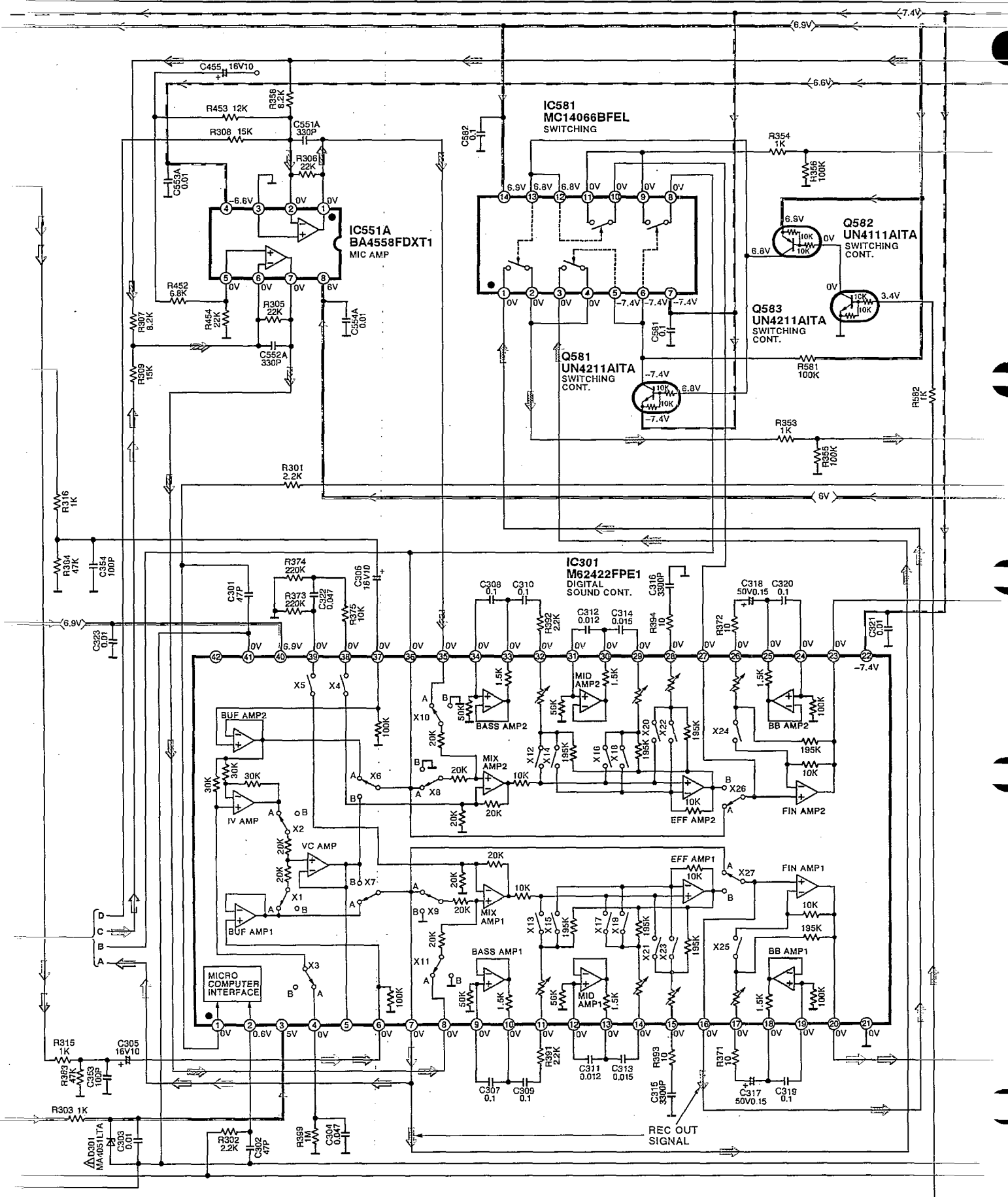

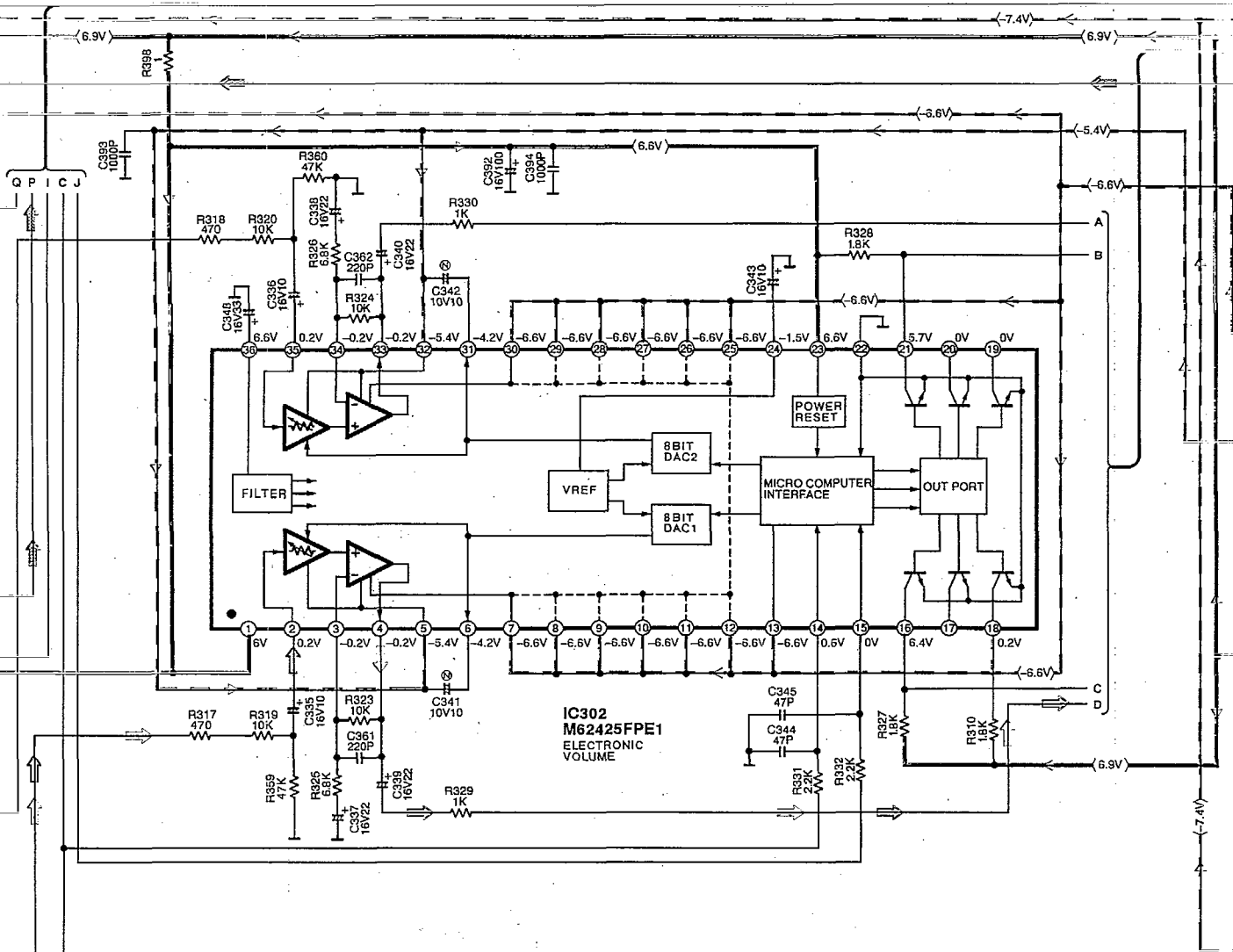
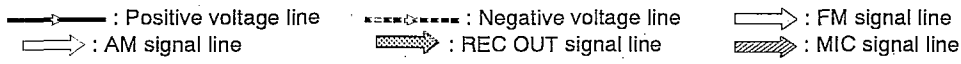

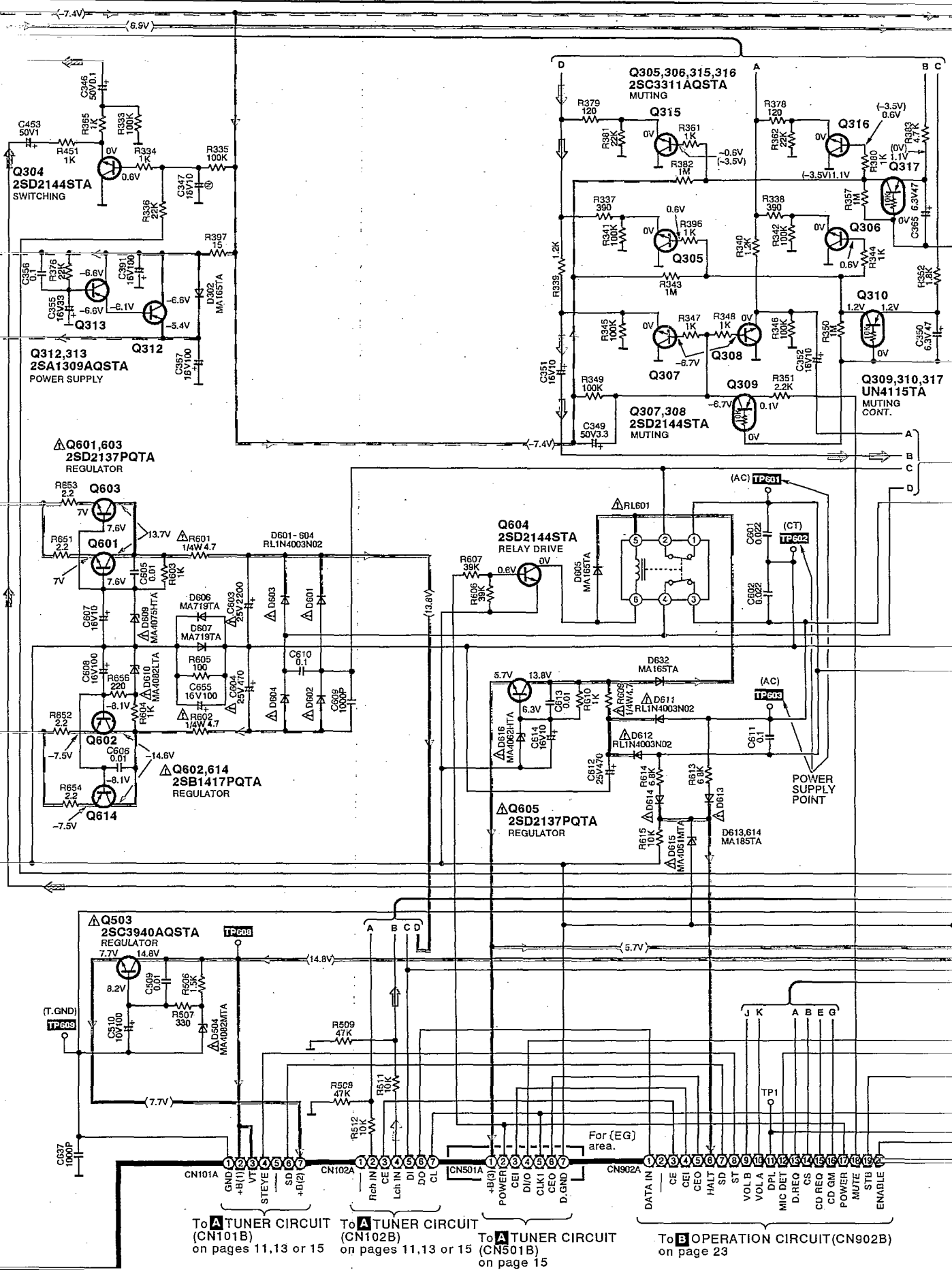

C MAIN CIRCUIT (P.C.Board: on page 29)



To **A** TUNER CIRCUIT (CN101B) on pages 11,13 or 15
 To **A** TUNER CIRCUIT (CN102B) on pages 11,13 or 15
 To **A** TUNER CIRCUIT (CN501B) on page 15
 To **B** OPERATION CIRCUIT (CN902B) on page 23

 : FM signal line
  : AM signal line
  : REC OUT signal line
  : MIC signal line
 : Center speaker drive signal line
  : Surround speaker drive signal line

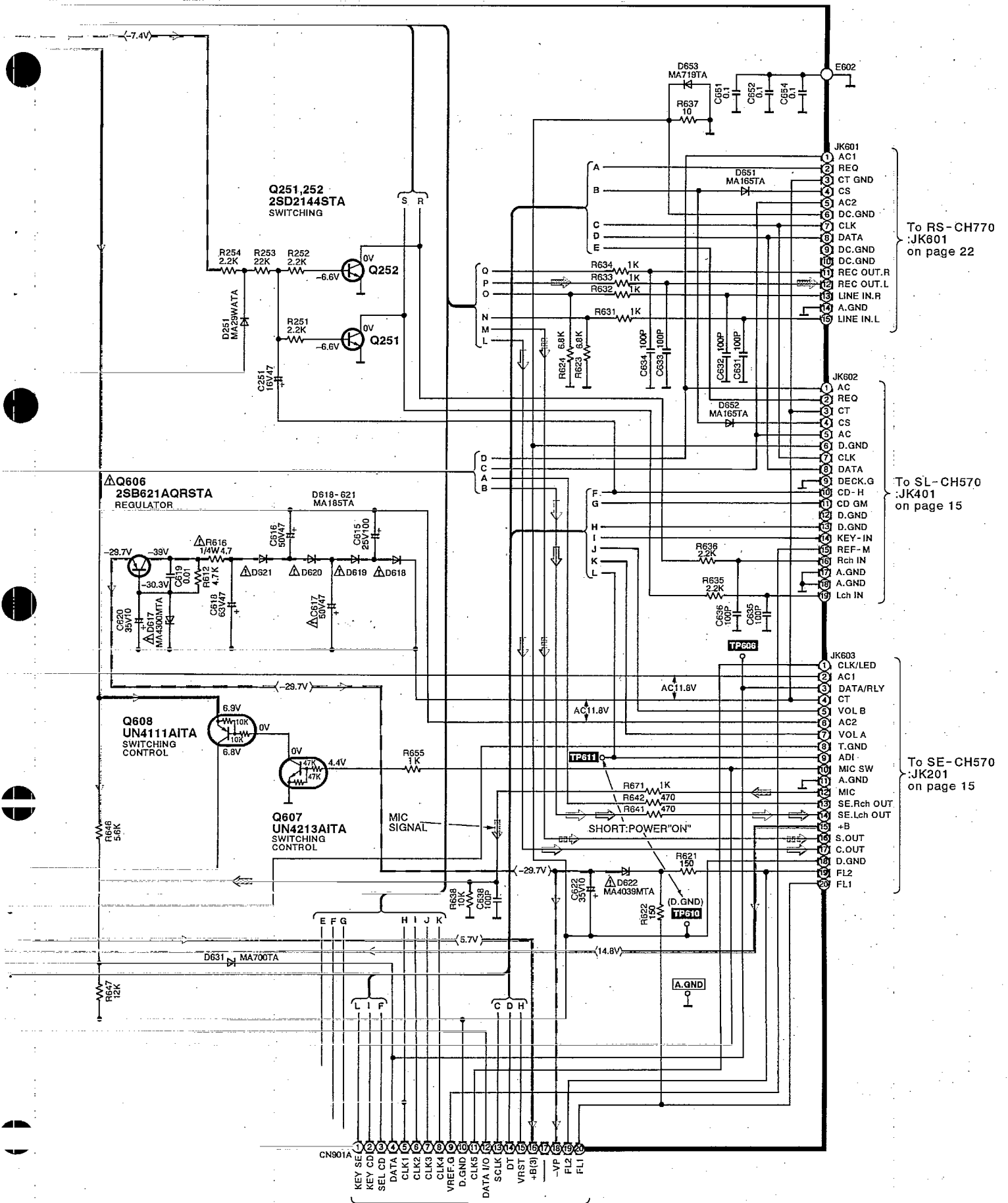

To RS-CH770
:JK601
on page 22

To SL-CH570
:JK401
on page 15

To SE-CH570
:JK201
on page 15

To **B** OPERATION CIRCUIT(CN901B)
on page 23

B OPERATION CIRCUIT (P.C.Board : on page 28)

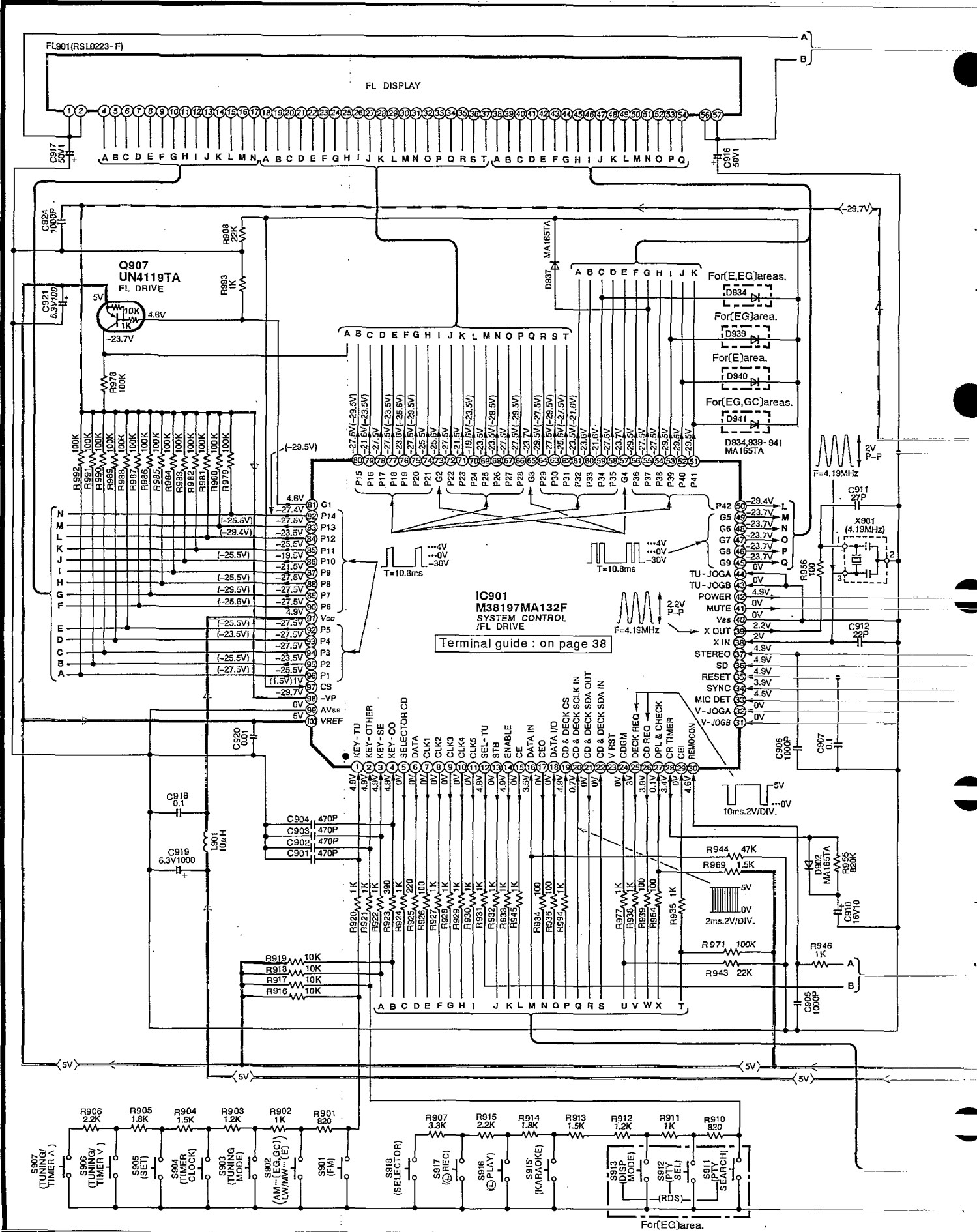

→ : Positive voltage line ←←←← : Negative voltage line

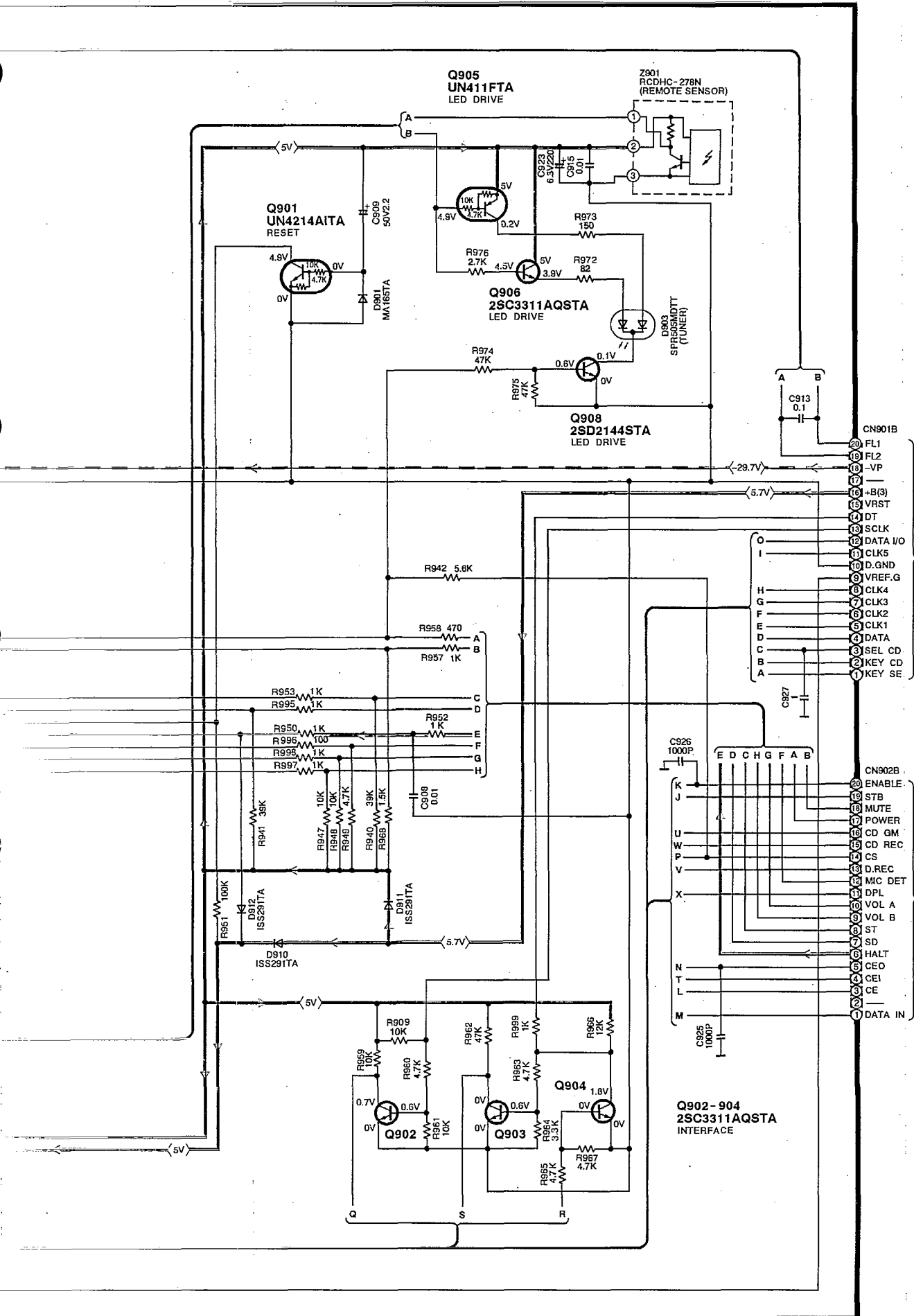

To MAIN CIRCUIT (CN901A) on page 21

To MAIN CIRCUIT (CN902A) on page 20

D DOLBY PRO LOGIC CIRCUIT (P.C.Board: on page 30)

- : Positive voltage line
- : Negative voltage line
- : FM signal line
- : AM signal line
- : REC OUT signal line
- : MIC signal line
- : Center speaker drive signal line
- : Surround speaker drive signal line

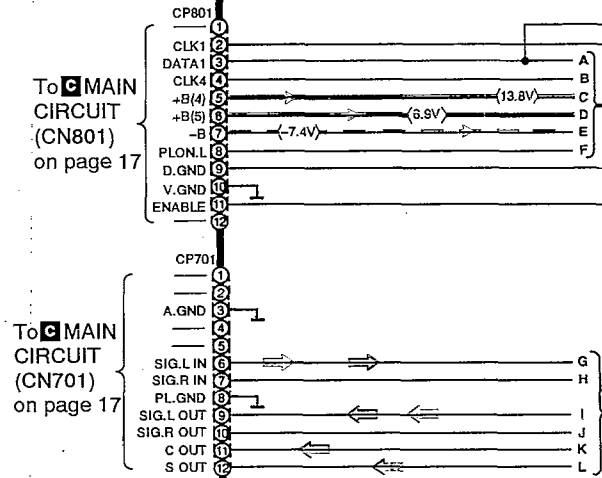

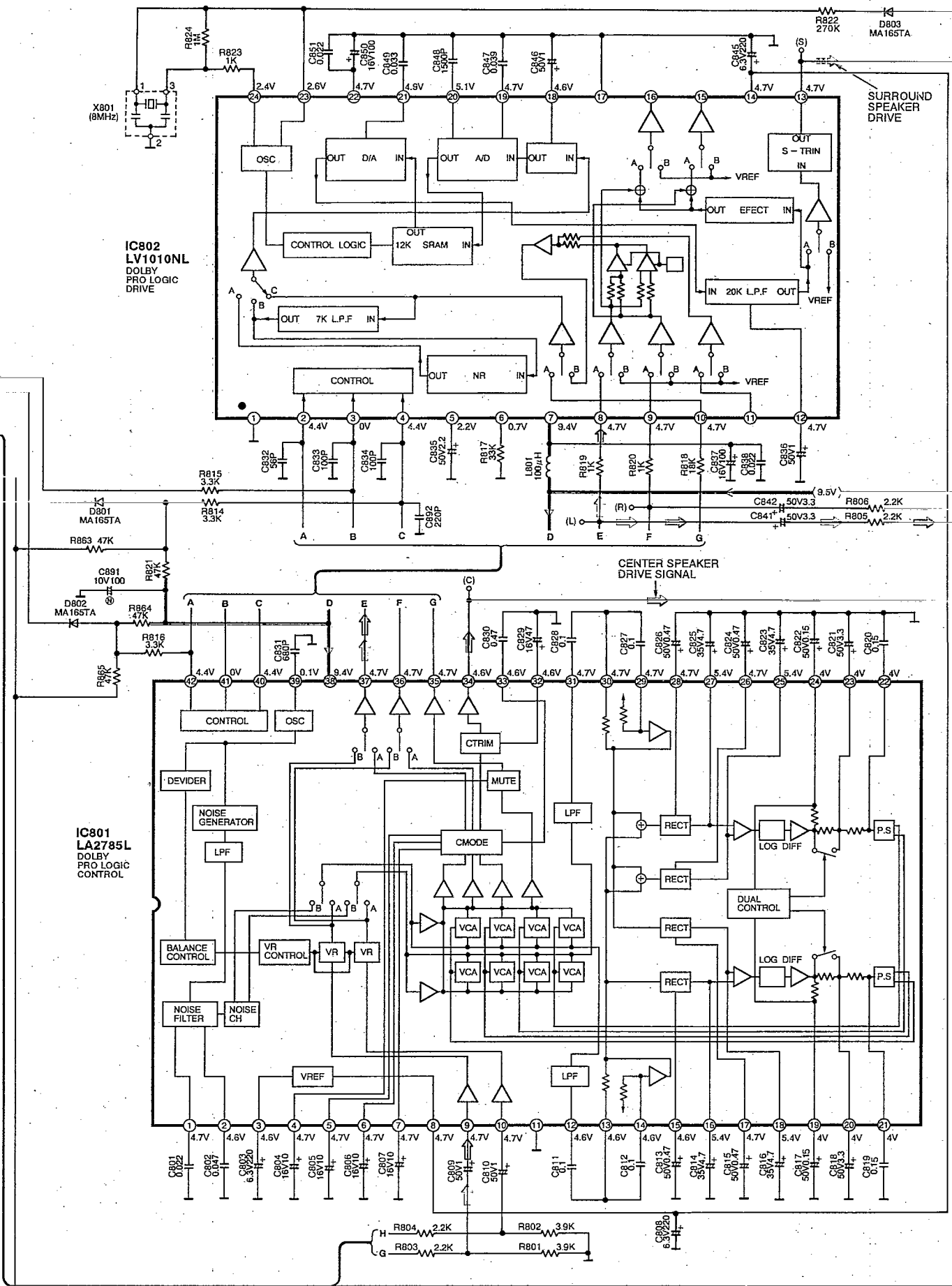

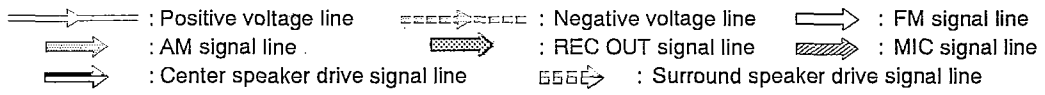

D DOLBY PRO LOGIC CIRCUIT (P.C.Board: on page 30)

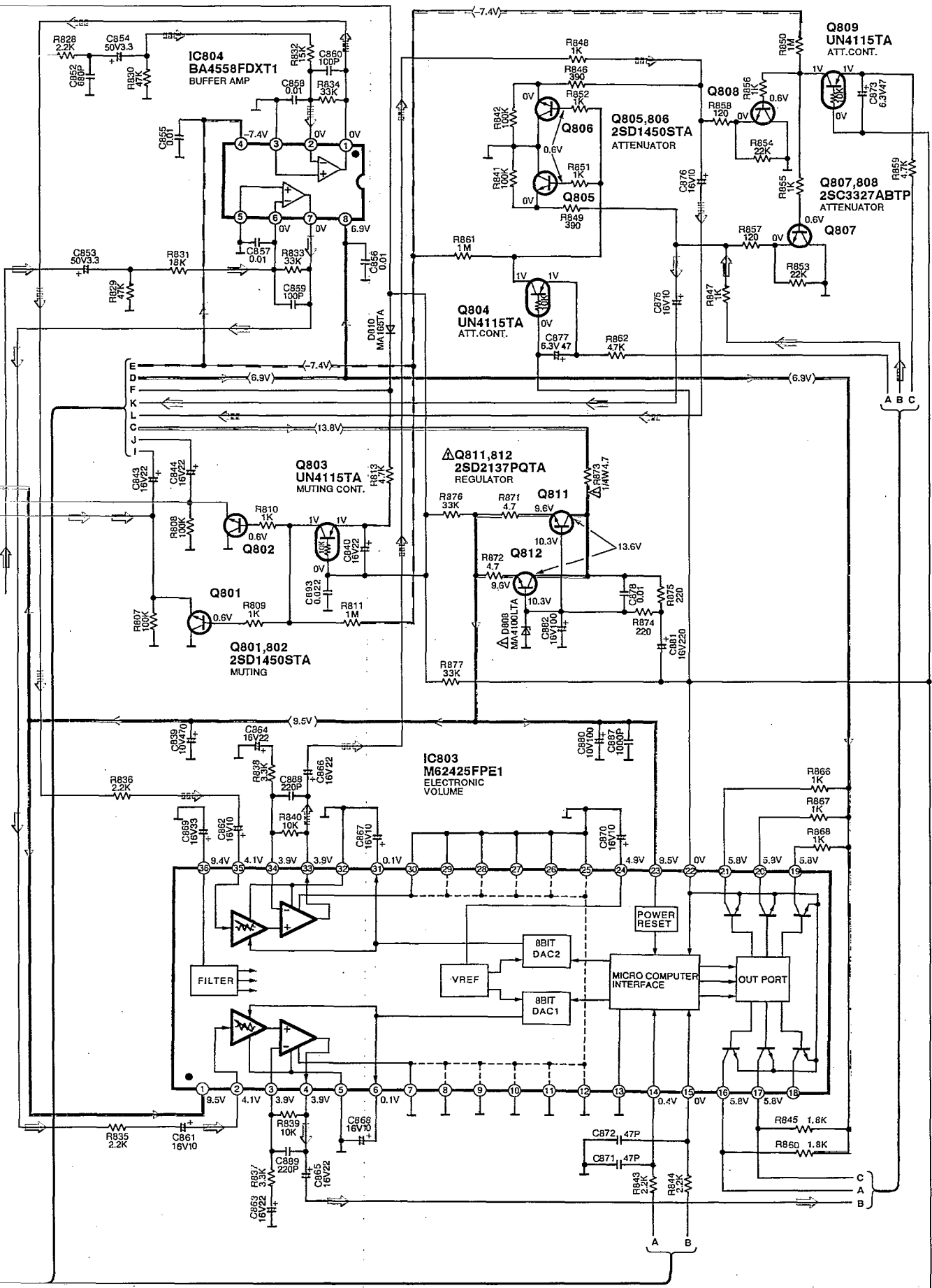

Printed Circuit Board Diagram

• This circuit board diagram may be modified at any time with the development of new technology.

A TUNER P.C.B. (REP1930E-T)
For [GC] area.

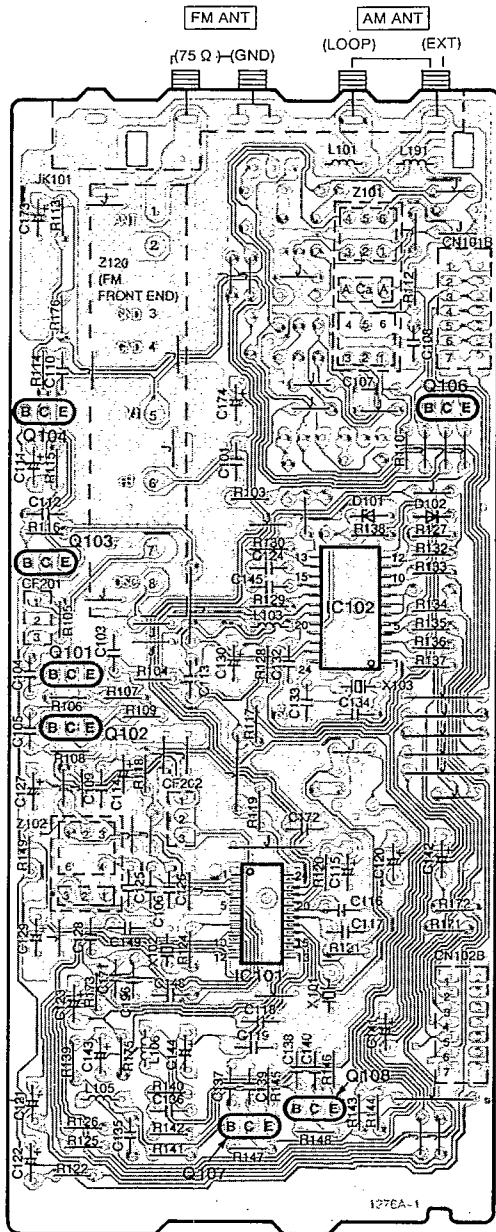

A TUNER P.C.B. (REP2151C-T)
For [EG] area.

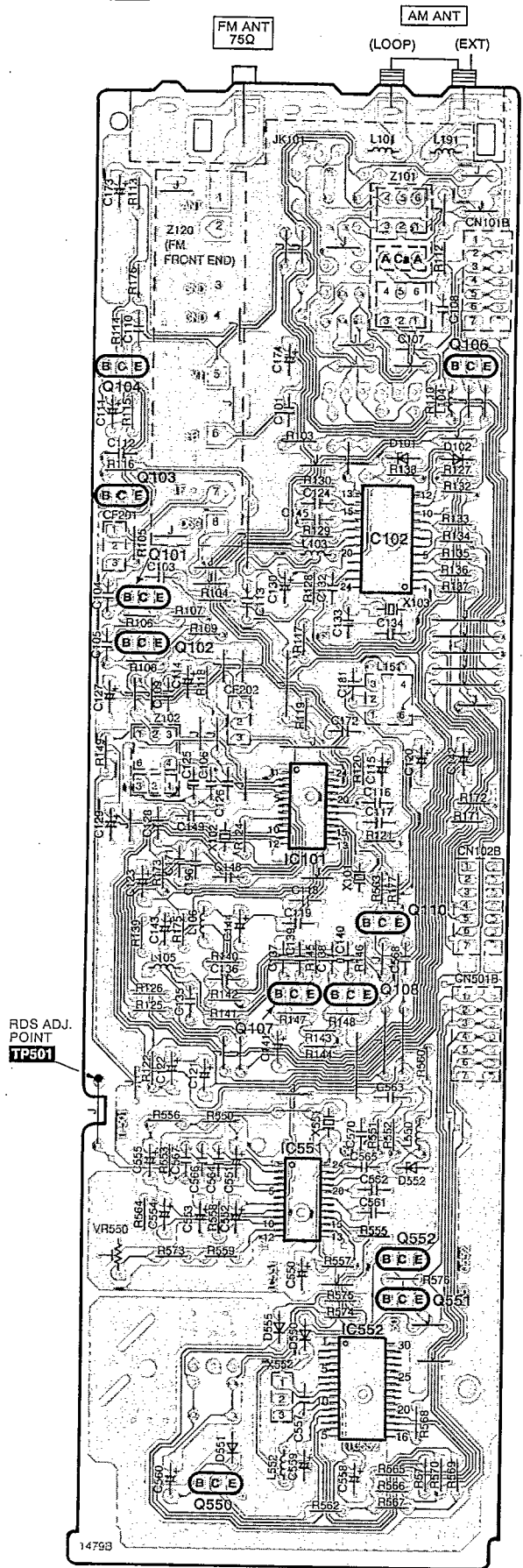

A TUNER P.C.B. (REP1930F-T)
For [E] area.

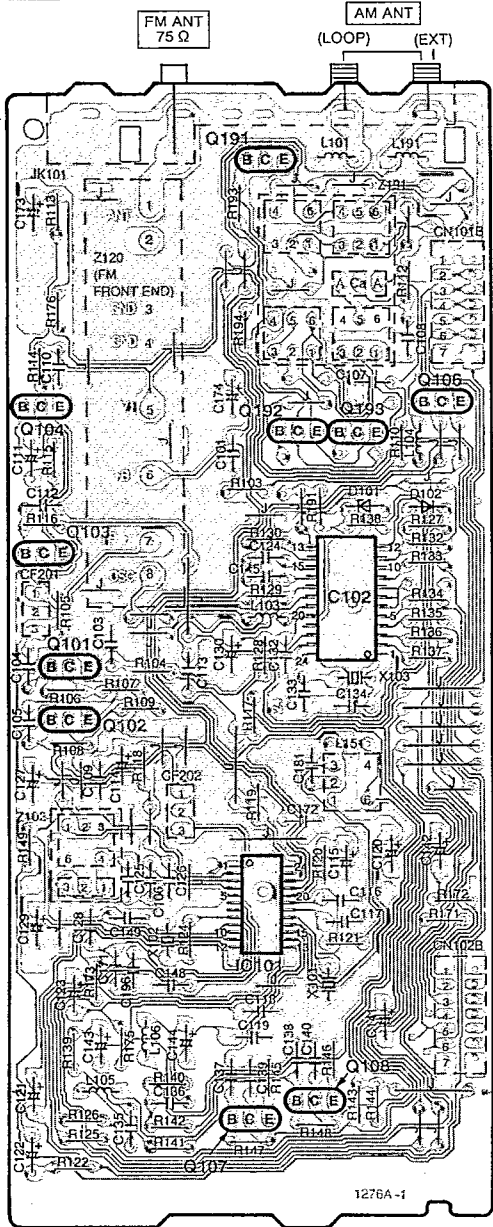

**B OPERATION P.C.B. (REP2365A-S...[E]
REP2365B-S...[EG]
REP2365C-S...[GC])**

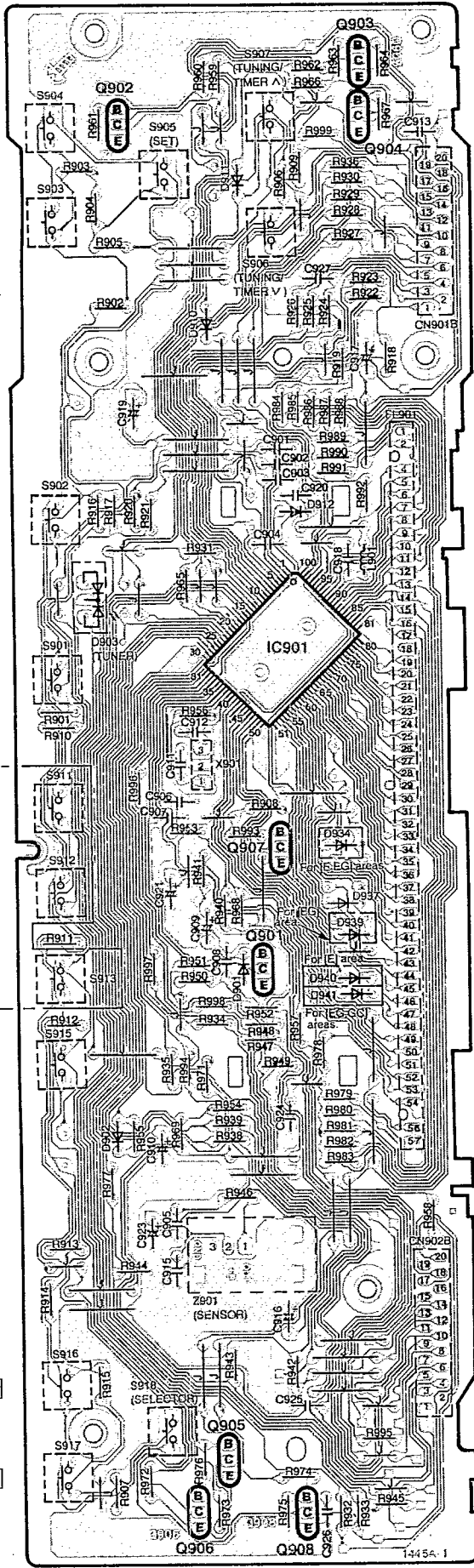

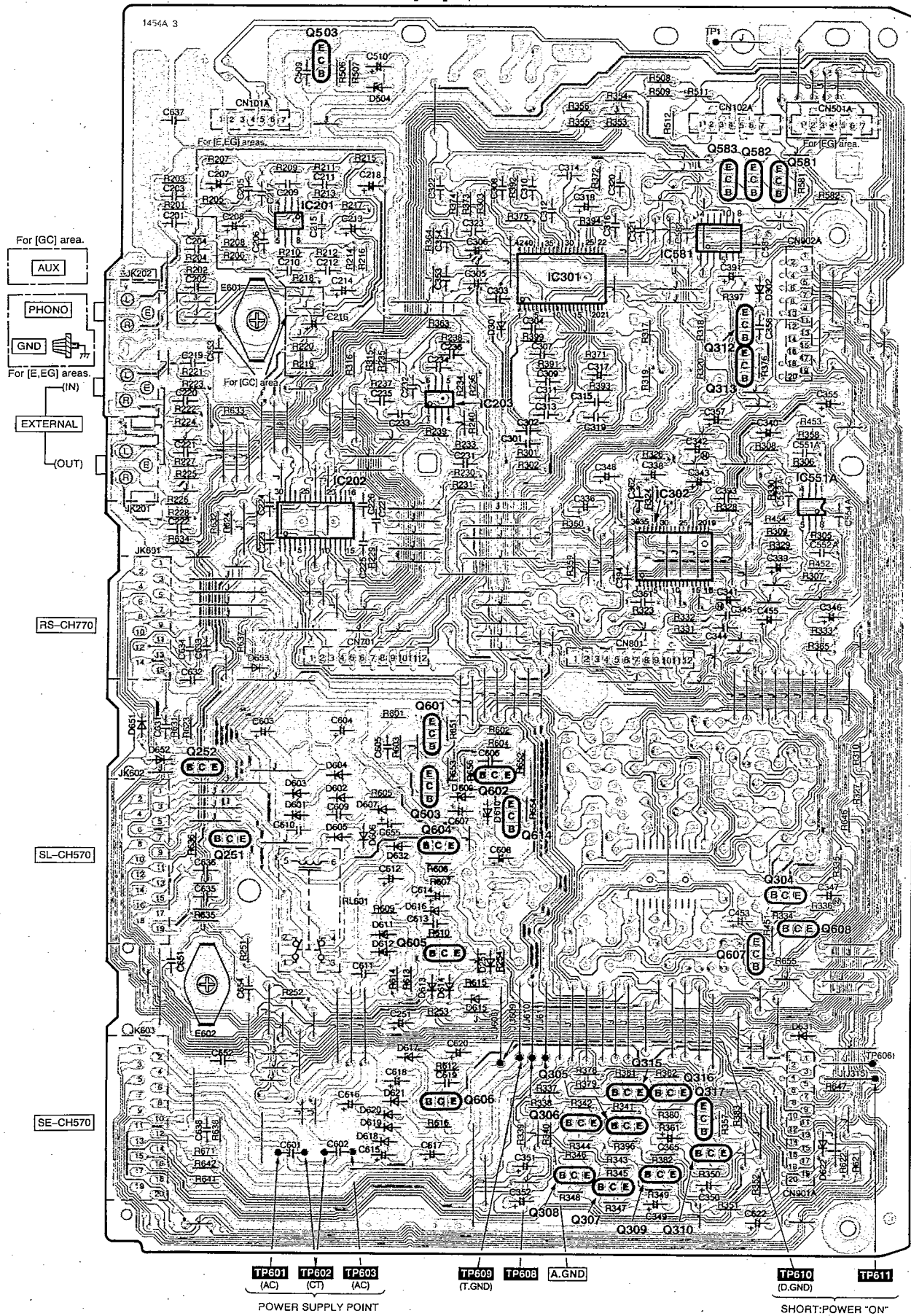

- TIMER/CLOCK
- TUNING MODE
- [EG,GC]...AM
[E]...LW/MW
- FM
- For [EG] area.
- (PTY SEARCH)
- (PTY SEL)
- RDS
- (DISP MODE)
- KARAOKE
- (PLAY)
- (REC)

C MAIN P.C.B. (REP2120H-M...[E])
 (REP2120K-M...[GC])
 (REP2120L-M...[EG])

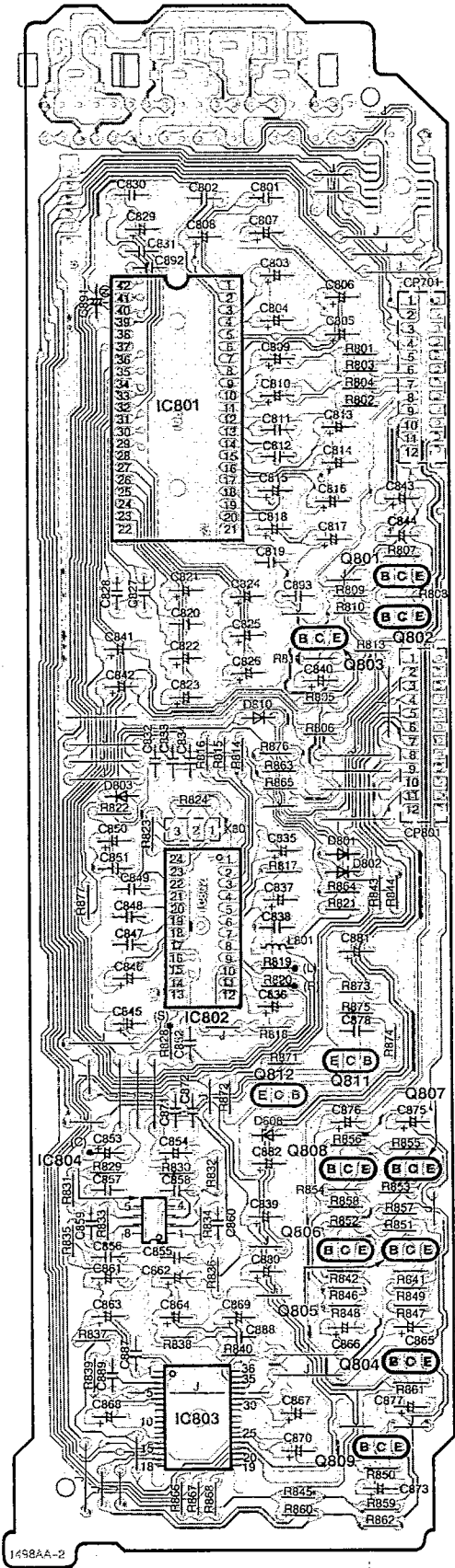

D DOLBY PRO LOGIC P.C.B.
(REP2172B-T)

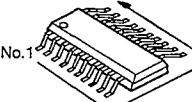
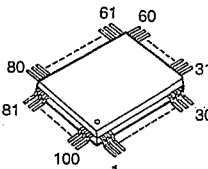
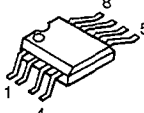
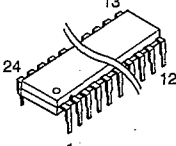
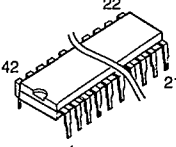
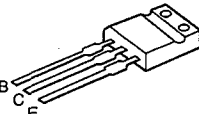
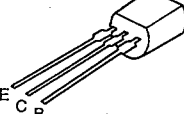
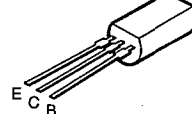
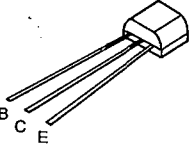
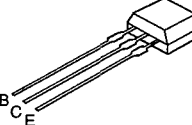

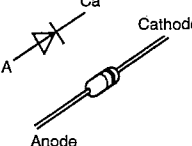
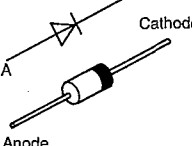
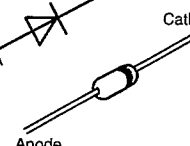
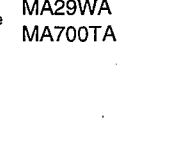
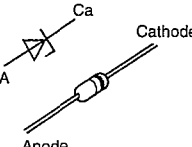
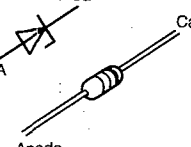
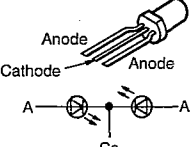
	AN6558SFE2	8PIN	NJU7313AMT2	30PIN			
	M5219FPTA	8PIN	M62425FPE1	36PIN			
	MC14066BFEL	14PIN	M62422FPE1	42PIN			
	LA1832MH-TEL	24PIN					
	LA2230M-TE-L	24PIN					
LC7218M-TE-L	24PIN						
LC65124F4H05	30PIN						
LA2785L	2SB1417PQTA	2SD2137PQTA	2SB621A-R	2SC3940AQSTA	2SC3327-A	2SD2144S	
							
	2SA1309A-R UN4115 2SC2785FE UN4119 2SC2787L UN4211 2SC3311A-Q UN4213AITA 2SC3311ARSTA UN4214TA 2SD1450RTA UN4111FTA UN4111		MA185TA MA719TA 	RL1N4003N02 		1SS291TA MA165 MA29WA MA700TA	
MA4100LTA MA4300M 		MA4039MTA MA4051-L MA4051MTA MA4062-H MA4075HTA MA4082LTA MA4082MTA	SPR505MDTT 				

■ Wiring Connection Diagram

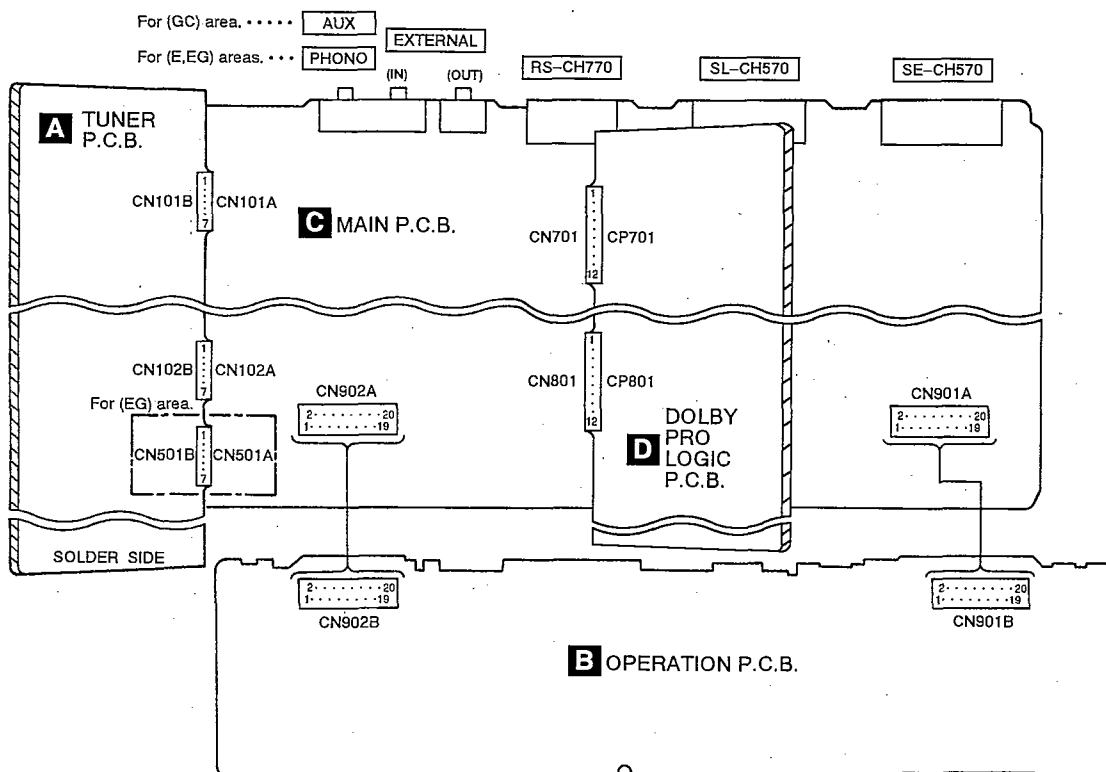

Block Diagram

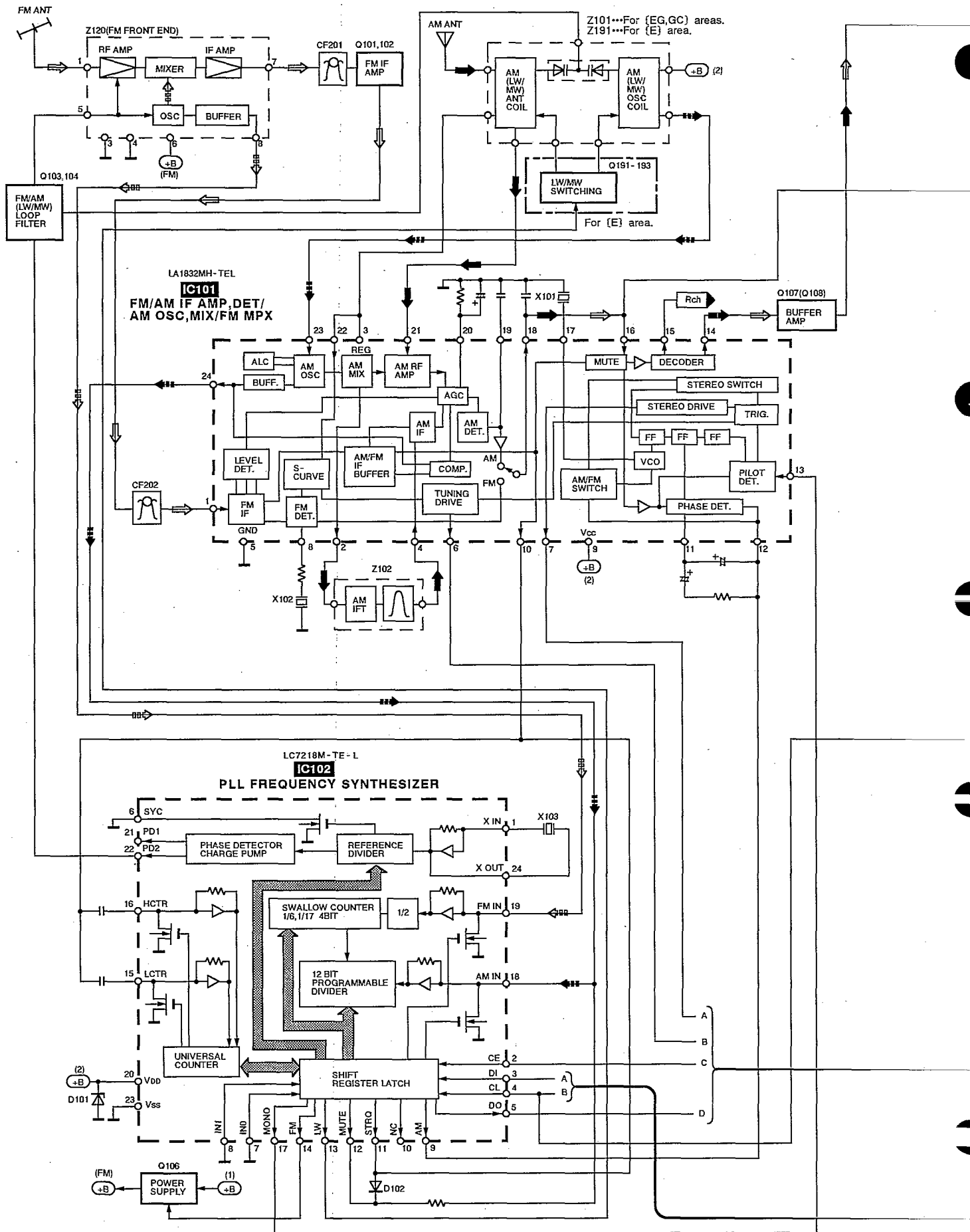

For (EG) area.

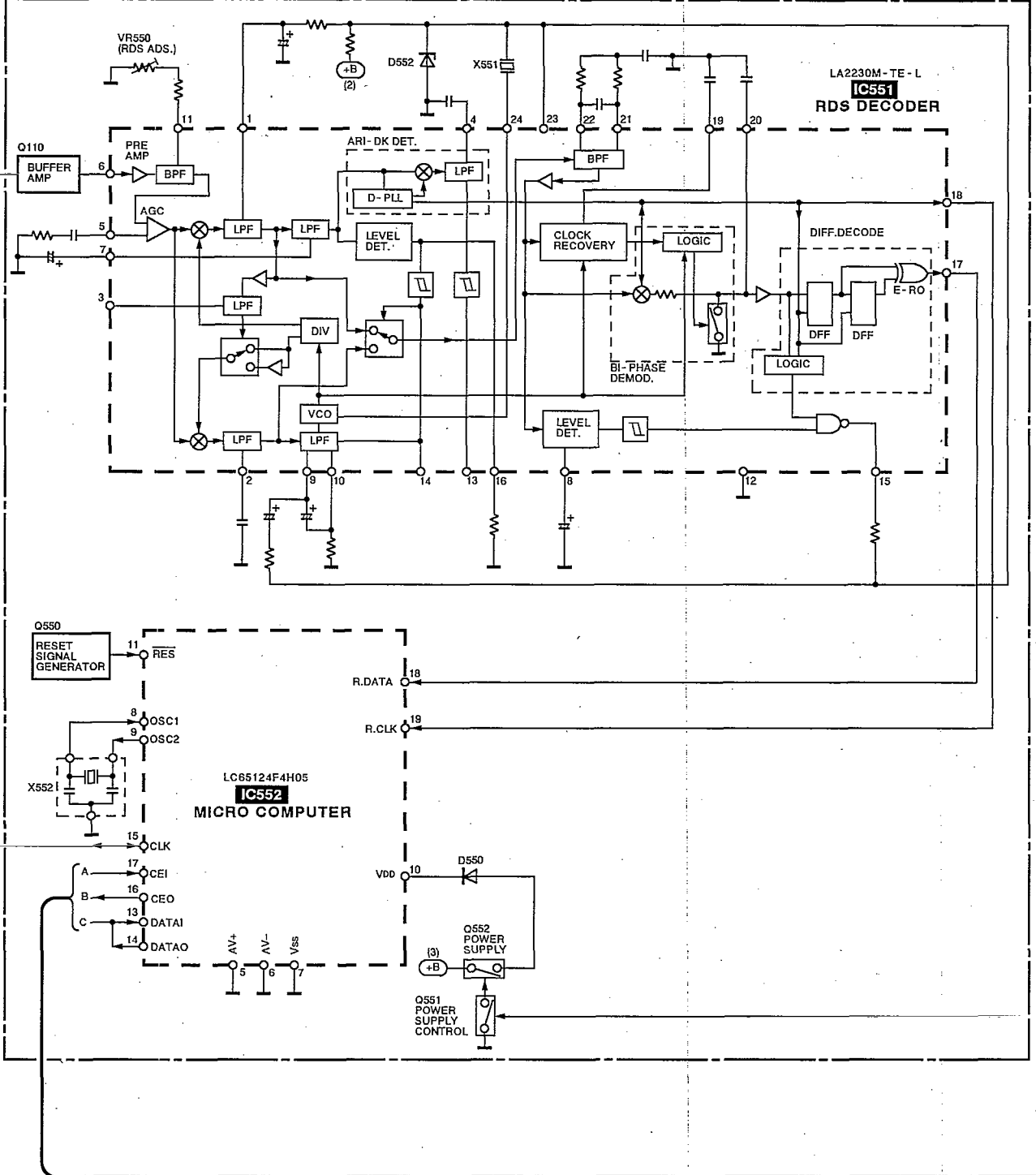

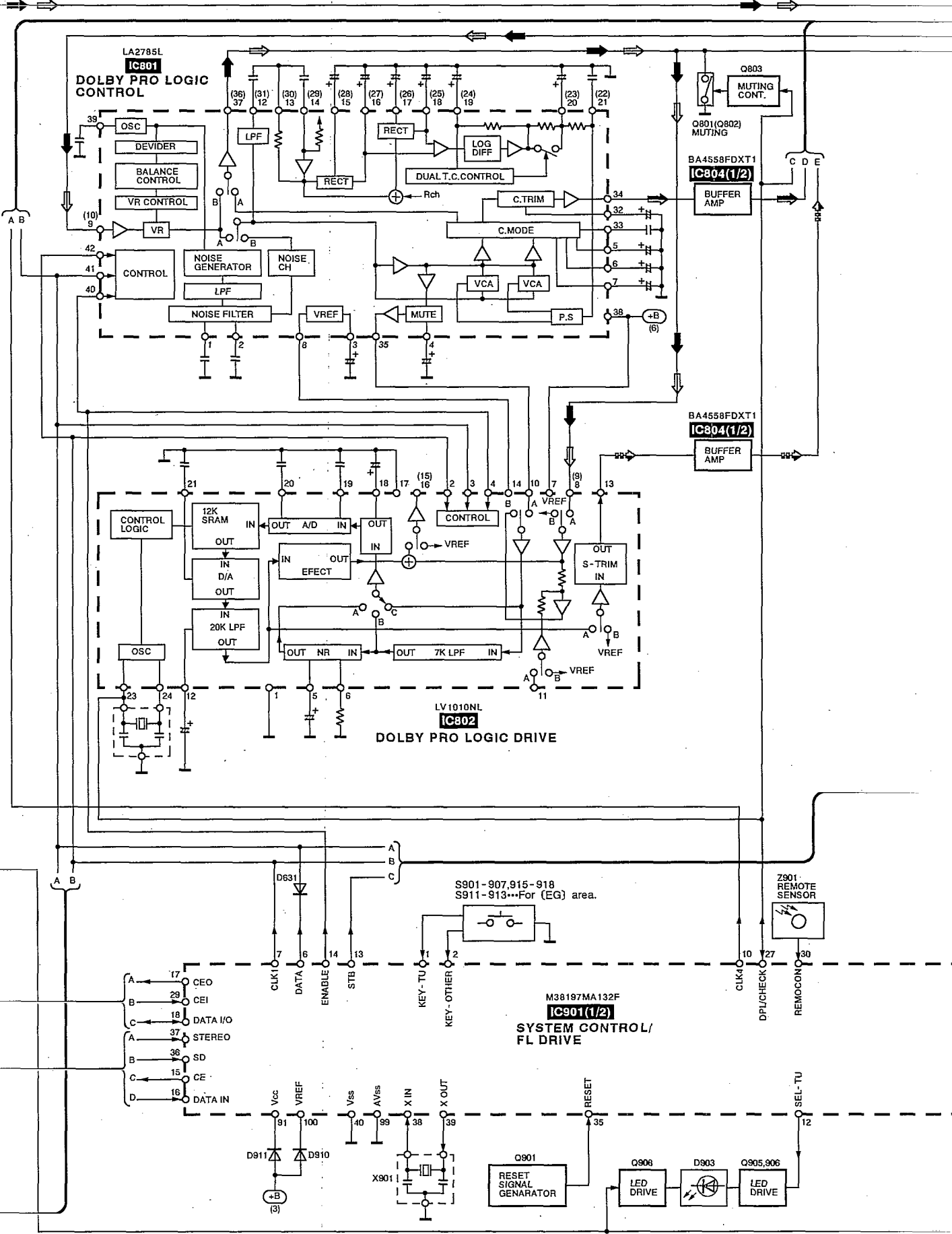

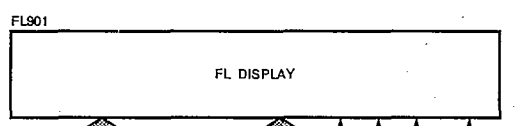
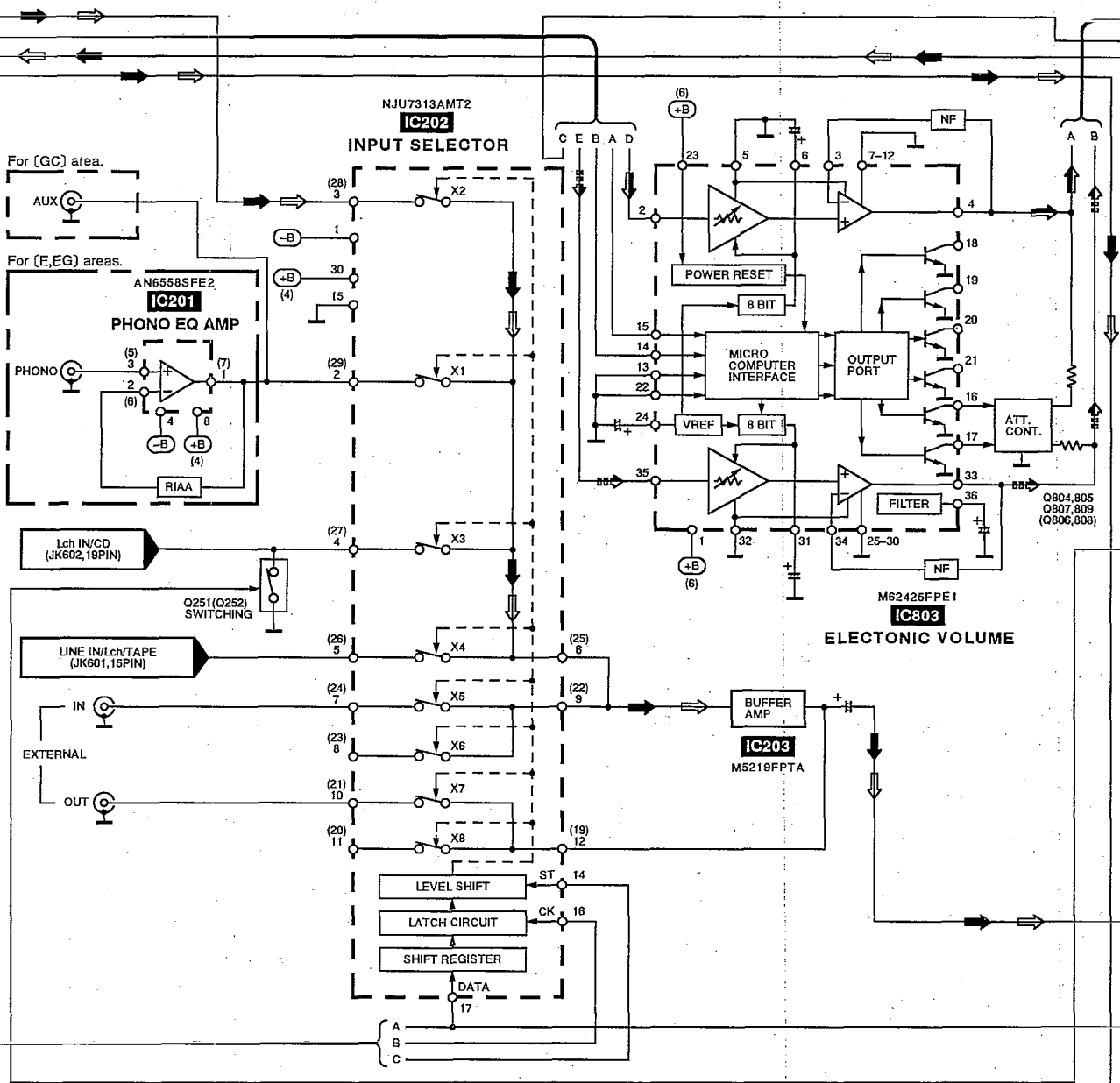

74-80, 82-90, 92-96
P1 P2

66-72, 88-84, 90-96
G8 G5 G4 G3 G2 G1

Q907
FL DRIVE

CLK3 9
CLK2 8

MUTE 41

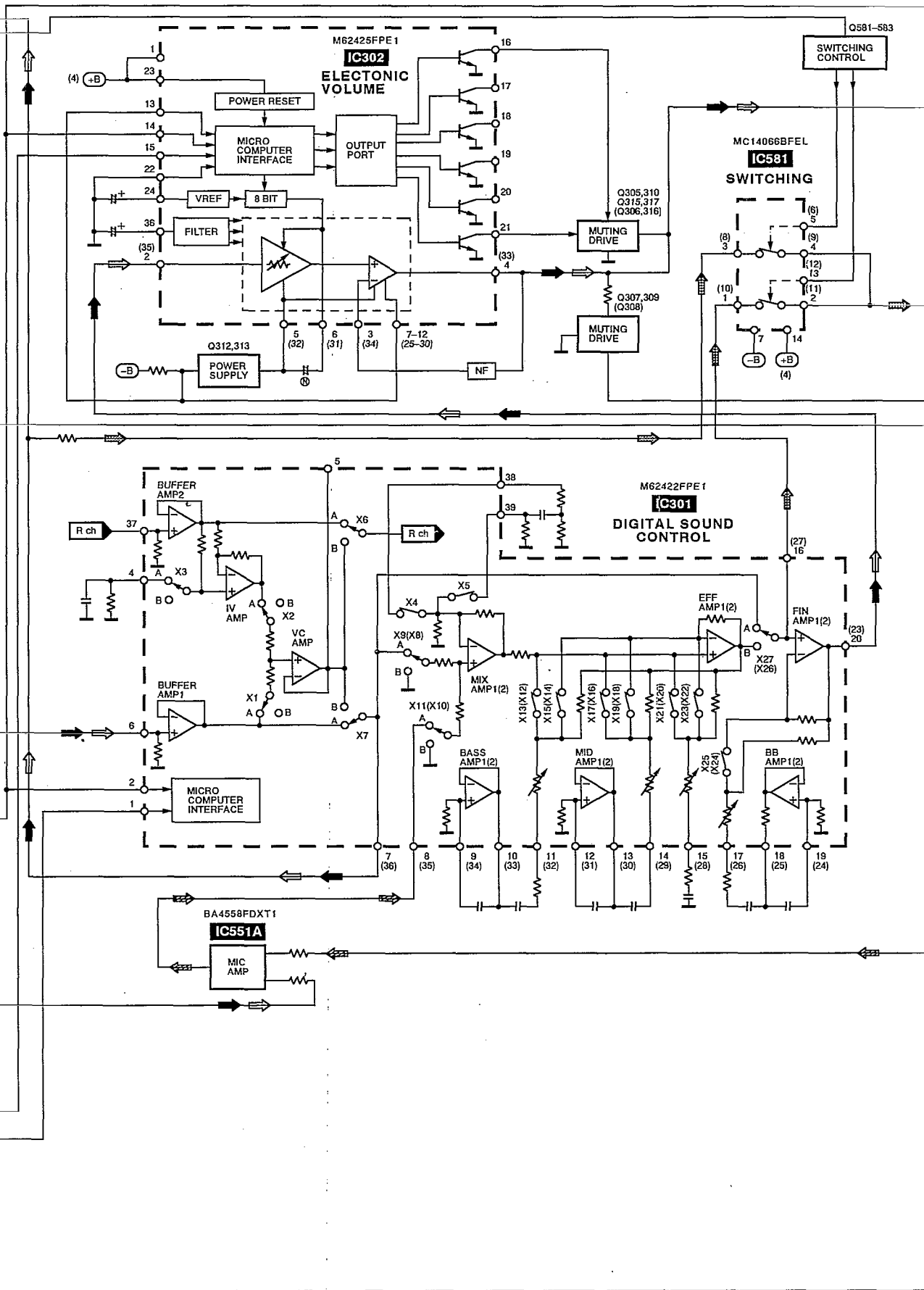

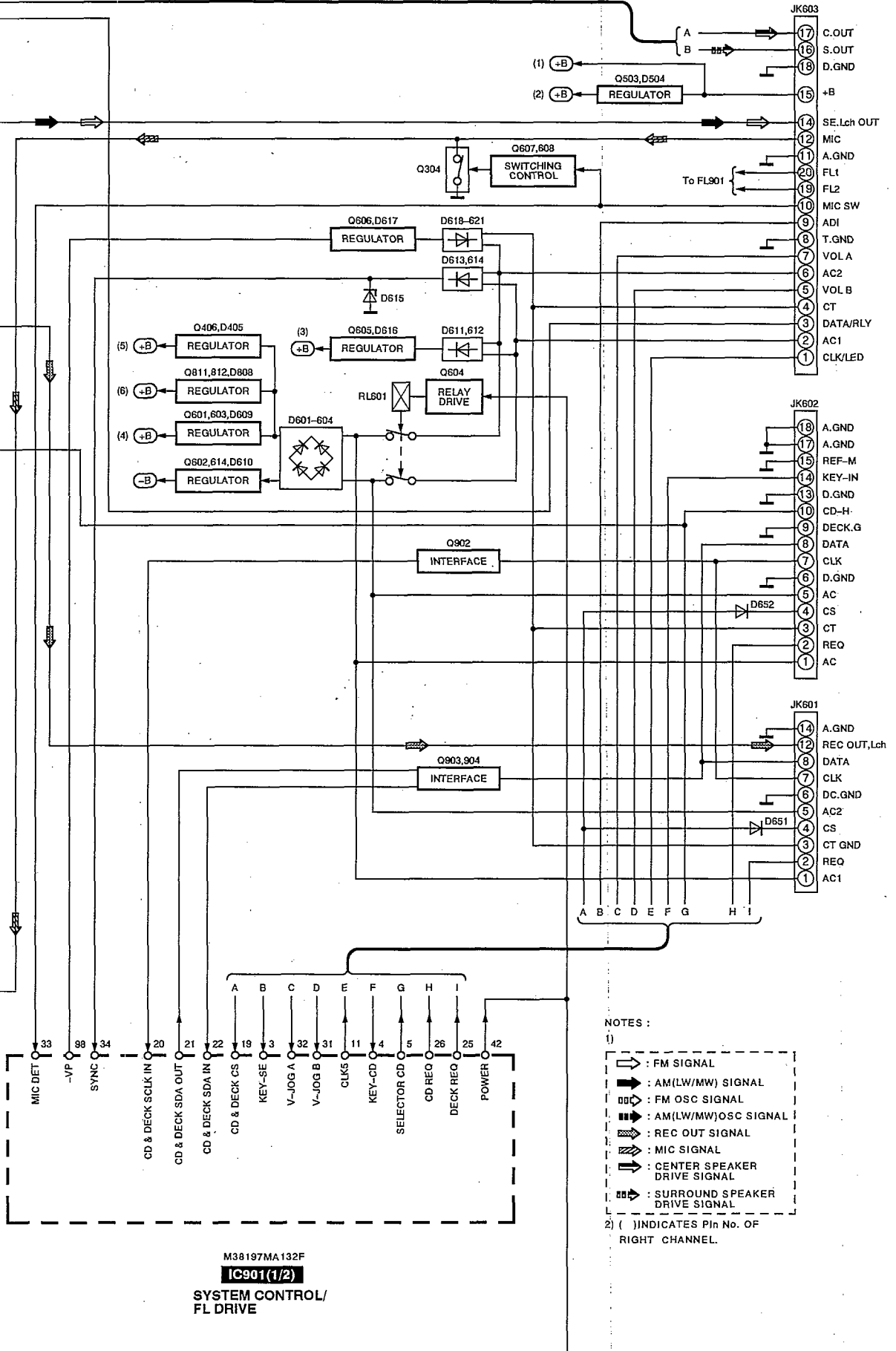

M38197MA132F
IC901(1/2)
 SYSTEM CONTROL/
 FL DRIVE

- NOTES:
- : FM SIGNAL
 - : AM(LW/MW) SIGNAL
 - : FM OSC SIGNAL
 - : AM(LW/MW)OSC SIGNAL
 - : REC OUT SIGNAL
 - : MIC SIGNAL
 - : CENTER SPEAKER DRIVE SIGNAL
 - : SURROUND SPEAKER DRIVE SIGNAL
- 2) () INDICATES Pin No. OF RIGHT CHANNEL.

Function of IC Terminals

● IC901 (M38197MA132F)

Pin No.	Terminal Name	I/O	Function
1	KEY-TU	I	Tuner operation switch signal input
2	KEY-OTHER	I	Other operation switch signal input
3	KEY-SE	I	SE-CH570 operation switch signal input
4	KEY-CD	I	SL-CH570 operation switch signal input
5	SELECTOR CD	O	SL-CH570 power control signal output
6	DATA	O	Data output for NJU7313, M62422, M62425, LC7218, LA2785 and LV1011
7	CLK1	O	Clock output for NJU7313, LC7218, LA2785, LV1011 and LC65104
8	CLK2	O	Clock output for M62422 (Digitalsound controller)
9	CLK3	O	Clock output for M62425 (Main volume)
10	CLK4	O	Clock output for M62425 (Surround volume)
11	CLK5	O	LED (D601, D602) (SE-CH570) drive signal output
12	SEL_TU	O	LED (D903-TUNER ON) drive signal output
13	STB	O	STB signal output for NJU7313
14	ENABLE	O	Enable signal output for LA2785 and LV1011
15	CE	O	Chip enable signal output for LC7218
16	DATA IN	I	Data input from LC7218
17	CEO	O	Serial data output terminal for (EG) area only
18	DATA I/O	I/O	Serial data input/output terminal for (EG) area only
19	CD & DECK CS	I	Serial data communication starting signal input
20	CD & DECK SCLK IN	I	Serial clock input
21	CD & DECK SDA OUT	O	Serial data output
22	CD & DECK SDA IN	I	Serial data input
23	V RST	—	Not used
24	CDGM	—	Not used
25	DECK REQ	O	RS-CH770 request signal output
26	CD REQ	O	SL-CH570 request signal output
27	DPL & CHECK	I/O	Clock check signal
28	CR TIMER	I/O	Capacitor and resistor oscillation terminal
29	CEI	I	Serial data input terminal for (EG) area only
30	REMOCON	I	Remote control signal input
31	V-JOGB	I	Volume control signal input
32	V-JOGA	I	

Pin No.	Terminal Name	I/O	Function
33	MIC DET	I	Microphone connecting detect signal input
34	SYNC	I	AC power source input terminal
35	RESET	I	Reset signal input
36	SD	I	SD signal input for tuner circuit
37	STEREO	I	STEREO signal input for tuner circuit
38	X IN	I	Connected to the ceramic oscillator
39	X OUT	O	
40	Vss	—	GND terminal
41	MUTE	O	Muting signal output
42	POWER	O	Power control signal output
43	TU-JOGB	I	Not used
44	TU-JOGA	I	
45-49	G9 ~ G5	O	Grid signal output
50-56	P42 ~ P36	O	Segment signal output
57	G4	O	Grid signal output
58-64	P35 ~ P29	O	Segment signal output
65	G3	O	Grid signal output
66-72	P28 ~ P22	O	Segment signal output
73	G2	O	Grid signal output
74-80	P21 ~ P15	O	Segment signal output
81	G1	O	Grid signal output
82-90	P14 ~ P6	O	Segment signal output
91	VCC	—	Power supply (+5V)
92-96	P5 ~ P1	O	Segment signal output
97	CS	I	Scan signal input
98	-VP	—	Negative power supply
99	AVSS	—	Connect to GND
100	VREF	—	Reference voltage input

● IC552 (LC65124F4H05) for (EG) area

Pin No.	Terminal Name	I/O	Function
1	PB0	O	Not used
2	PB1	O	Not used
3	PB2	O	Not used
4	PB3	O	Not used
5	AV+	—	Not used, connected to GND
6	AV-	—	Not used, connected to GND
7	VSS	—	GND terminal
8	OSC1	I	Oscillating terminal (f = 4 MHz)
9	OSC2	O	Oscillating terminal (f = 4 MHz)
10	VDD	—	+5 V
11	/RES	I	Reset signal input
12	TEST	—	Not used, connected to GND
13	DATAI	I	Serial data input
14	DATAO	O	Serial data output
15	CLK	I	Serial clock signal input
16	CEO	O	Serial data output detection terminal
17	CEI	I	Serial data input detection terminal
18	R.DATA	I	RDS data signal input
19	R. CLK	I	RDS clock signal input
20	NC	O	Not used
21	PD0	O	Not used
22	PD1	O	Not used
23	PD2	O	Not used
24	PD3	O	Not used
25	PD0	O	Not used
26	PE1	O	Not used
27	SSL	O	Not used
28	PA1	O	Not used
29	PA2	O	Not used
30	PA3	O	Not used

Replacement Parts List

Notes: *Important safety notice:

Components identified by Δ mark have special characteristics important for safety.

Furthermore, special parts which have purposes of fire-retardant (resistors), high-quality sound (capacitors), low-noise (resistors), etc. are used.

When replacing any of components, be sure to use only manufacture's specified parts shown in the parts list.

*The parenthesized indications in the Remarks columns specify the areas. (Refer to the cover page for area.)

Parts without these indications can be used for all areas.

Ref. No.	Part No.	Part Name & Description	Remarks	Ref. No.	Part No.	Part Name & Description	Remarks
		INTEGRATED CIRCUIT(S)		Q606	2SB621A-R	TRANSISTOR	Δ
IC101	LA1832MH-TEL	IC, FM/AM(LW/MW) IF AMP.		Q607	UN4213AITA	TRANSISTOR	
IC102	LC7218M-TE-L	IC, PLL FREQ. SYNTHESIZER		Q608	UN4111	TRANSISTOR	
IC201	AN6558SFE2	IC, PHONO EQ AMP.	(E, EG)	Q614	2SB1417PQTA	TRANSISTOR	Δ
IC202	NJU7313AMT2	IC, INPUT SELECTOR		Q801, 802	2SD1450RTA	TRANSISTOR	
IC203	M5219FPTA	IC, BUFFER AMP.		Q803, 804	UN4115	TRANSISTOR	
IC301	M62422FPE1	IC, DIGITAL SOUND CONT.		Q805, 806	2SD1450RTA	TRANSISTOR	
IC302	M62425FPE1	IC, ELECTRONIC VOLUME		Q807, 808	2SC3327-A	TRANSISTOR	
IC551A	BA4558FDXT1	IC, MIC AMP.		Q809	UN4115	TRANSISTOR	
IC551	LA2230M-TE-L	IC, RDS DECODER	(EG)	Q811, 812	2SD2137PQTA	TRANSISTOR	Δ
IC552	LC65124F4HD5	IC, MICRO COMPUTER	(EG)	Q901	UN4214TA	TRANSISTOR	
IC581	MC14066BFEL	IC, SWITCHING		Q902-904	2SC3311A-Q	TRANSISTOR	
IC801	LA2785L	IC, DOLBY PRO LOGIC CONTROL		Q905	UN411FTA	TRANSISTOR	
IC802	LV1010NL	IC, DOLBY PRO LOGIC DRIVE		Q906	2SC3311A-Q	TRANSISTOR	
IC803	M62425FPE1	IC, ELECTRONIC VOLUME		Q907	UN4119	TRANSISTOR	
IC804	BA4558FDXT1	IC, BUFFER AMP.		Q908	2SD2144S	TRANSISTOR	
IC901	M38197MA132F	IC, SYSTEM CONTROL/FL DRIVE				DIODE(S)	
		TRANSISTOR(S)		D101	MA4051MTA	DIODE	Δ
Q101, 102	2SC2787L	TRANSISTOR		D102	MA165	DIODE	
Q103, 104	2SC2785FE	TRANSISTOR		D251	MA23WA	DIODE	
Q106	UN4111	TRANSISTOR	(E, EG)	D301	MA4051-L	DIODE	Δ
Q106	UN411FTA	TRANSISTOR	(GC)	D302	MA165	DIODE	
Q107, 108	2SC3311ARSTA	TRANSISTOR		D504	MA4082MTA	DIODE	Δ
Q110	2SC3311ARSTA	TRANSISTOR	(EG)	D550, 551	MA165	DIODE	(EG)
Q191-193	2SC3311ARSTA	TRANSISTOR	(E)	D552	MA4051MTA	DIODE	(EG) Δ
Q251, 252	2SD2144S	TRANSISTOR		D555	MA165	DIODE	(EG)
Q304	2SD2144S	TRANSISTOR		D601-604	RL1N4003N02	DIODE	Δ
Q305, 306	2SC3311A-Q	TRANSISTOR		D605	MA165	DIODE	
Q307, 308	2SD2144S	TRANSISTOR		D606, 607	MA719TA	DIODE	
Q309, 310	UN4115	TRANSISTOR		D609	MA4075HTA	DIODE	Δ
Q312, 313	2SA1309A-R	TRANSISTOR		D610	MA4082LTA	DIODE	Δ
Q315, 316	2SC3311A-Q	TRANSISTOR		D611, 612	RL1N4003N02	DIODE	Δ
Q317	UN4115	TRANSISTOR		D613, 614	MA185TA	DIODE	Δ
Q503	2SC3940AQSTA	TRANSISTOR	Δ	D615	MA4051MTA	DIODE	Δ
Q550, 551	UN4211	TRANSISTOR	(EG)	D616	MA4062-H	DIODE	Δ
Q552	UN4111	TRANSISTOR	(EG)	D617	MA4300M	DIODE	Δ
Q581	UN4211	TRANSISTOR		D618-621	MA185TA	DIODE	Δ
Q582	UN4111	TRANSISTOR		D622	MA4039MTA	DIODE	Δ
Q583	UN4211	TRANSISTOR		D631	MA700TA	DIODE	
Q601	2SD2137PQTA	TRANSISTOR	Δ	D632	MA165	DIODE	
Q602	2SB1417PQTA	TRANSISTOR	Δ	D651, 652	MA165	DIODE	
Q603	2SD2137PQTA	TRANSISTOR	Δ	D653	MA719TA	DIODE	
Q604	2SD2144S	TRANSISTOR		D801-803	MA165	DIODE	
Q605	2SD2137PQTA	TRANSISTOR	Δ	D808	MA4100LTA	DIODE	Δ
				D810	MA165	DIODE	

Ref. No.	Part No.	Part Name & Description	Remarks	Ref. No.	Part No.	Part Name & Description	Remarks
D901, 902	MA165	DIODE		S901	EVQ21405R	SW, FM	
D903	SPR505MDTT	L. E. D.		S902	EVQ21405R	SW, LW/MW (AM)	
D910-912	1SS291TA	DIODE		S903	EVQ21405R	SW, TUNING MODE	
D934	MA165	DIODE	(E, EG)	S904	EVQ21405R	SW, TIMER/CLOCK	
D937	MA165	DIODE		S905	EVQ21405R	SW, SET	
D939	MA165	DIODE	(EG)	S906	EVQ21405R	SW, TUNING/TIMER DOWN	
D940	MA165	DIODE	(E)	S907	EVQ21405R	SW, TUNING/TIMER UP	
D941	MA165	DIODE	(EG, GC)	S911	EVQ21405R	SW, PTY SEARCH	(EG)
		VARIABLE RESISTOR		S912	EVQ21405R	SW, PTY SEL	(EG)
VR550	EVNDCBA03B53	V. R. RDS ADJ.	(EG)	S913	EVQ21405R	SW, DISPLAY MODE	(EG)
		COMPONENT COMBINATION(S)		S915	EVQ21405R	SW, KARAOKE	
Z101	RLA2Z002M-T	COMPONENT COMBINATION	(EG, GC)	S916	EVQ21405R	SW, PLAY TIMER	
Z102	RLI2Z006M-T	COMPONENT COMBINATION		S917	EVQ21405R	SW, RECORD TIMER	
Z120	RAL0019	FM FRONT END	(E, EG)	S918	EVQ21405R	SW, SELECTOR	
Z120	RAL0006	FM FRONT END	(GC)			CONNECTOR(S)	
Z191	RLA6Z005M-T	COMPONENT COMBINATION	(E)	CN701	RJT057W012-1	CONNECTOR (12P)	
Z901	RCDHC-278N	REMOTE SENSOR		CN801	RJT057W012-1	CONNECTOR (12P)	
		COIL(S)		CN101A	RJT057W007-1	CONNECTOR (7P)	
L101	ELESNR68MA	COIL		CN102A	RJT057W007-1	CONNECTOR (7P)	
L103	ELEXTR47MA9	COIL		CN501A	RJT057W007-1	CONNECTOR (7P)	(EG)
L104	ELEXTI10KA9	COIL	(E, EG)	CN501B	RJT057W007-1	CONNECTOR (7P)	(EG)
L105, 106	ELELN822KL	COIL		CN901A	RJS1A6820	CONNECTOR (20P)	
L151	SLM1B10M-1M	COIL	(E, EG)	CN902A	RJS1A6820	CONNECTOR (20P)	
L191	ELESNR68MA	COIL		CN101B	RJU057W007	CONNECTOR (7P)	
L550	ELEXTI01KA9	COIL	(EG)	CN102B	RJU057W007	CONNECTOR (7P)	
L552	ELEXTI01KA9	COIL	(EG)	CN901B	RJS1A6820	CONNECTOR (20P)	
L801	ELESN101KA	COIL		CN902B	RJS1A6820	CONNECTOR (20P)	
L901	RLQA100JT-Y	COIL		CP701	RJU057W012	CONNECTOR (12P)	
		FILTER(S)		CP801	RJU057W012	CONNECTOR (12P)	
CF201	RLFFETNGD01L	CERAMIC FILTER	(E, EG)			GND PLATE	
CF201	RLFFETWND01M	CERAMIC FILTER	(GC)	E601, 602	SNE1004-2	GND PLATE	
CF202	RLFFETMGD01L	CERAMIC FILTER	(E, EG)			RELAY	
CF202	RLFFETWND01M	CERAMIC FILTER	(GC)	RL601	RSY0017M-0	RELAY	△
		OSCILLATOR(S)				JACK(S)	
X101	RSXZ456KM07M	OSCILLATOR (456 kHz)		JK101	RJH5210M	EXT ANT	(E, EG)
X102	RLFDGT05DD	OSCILLATOR (10.65 MHz)		JK101	RJH5404M	EXT ANT	(GC)
X103	RSXC7M20S05T	OSCILLATOR (7.2 MHz)		JK201	SJF3068-7N	EXT OUT	
X551	RSXZ456KM07M	OSCILLATOR (456 kHz)	(EG)	JK202	SJF3069-5N	EXT IN/PHONO (AUX)	
X552	RVCST4R00MT	OSCILLATOR (4 MHz)	(EG)	JK601	RJT065K15	SYSTEM CONNECTOR (15P)	
X801	EFOEC8004T4	OSCILLATOR (8 MHz)		JK602	RJT065K19	SYSTEM CONNECTOR (19P)	
X901	RSXC4M19S02T	OSCILLATOR (4.19 MHz)		JK603	RJT065K20	SYSTEM CONNECTOR (20P)	
		DISPLAY TUBE					
FL901	RSL0223-F	DISPLAY TUBE					
		SWITCH(ES)					

Notes : * Capacity values are in microfarads (μF) unless specified otherwise, P=Pico-farads (pF) F=Farads (F)
 * Resistance values are in ohms, unless specified otherwise, 1K=1,000(OHM) , 1M=1,000k(OHM)

Ref. No.	Part No.	Values & Remarks	Ref. No.	Part No.	Values & Remarks	Ref. No.	Part No.	Values & Remarks
		RESISTORS	R193	ERDS2TJ182	1/4W 1.8K (E)	R344	ERDS2TJ102	1/4W 1K
			R194	ERDS2TJ122	1/4W 1.2K (E)	R345, 346	ERDS2TJ104	1/4W 100K
R103	ERDS2TJ101	1/4W 100 (E, EG)	R195	ERDS2TJ222	1/4W 2.2K (E)	R347, 348	ERDS2TJ102	1/4W 1K
R103	ERDS2TJ271T	1/4W 270 (GC)	R201, 202	ERDS2TJ102	1/4W 1K (E, EG)	R349	ERDS2TJ104	1/4W 100K
R104	ERDS2TJ103	1/4W 10K (E, EG)	R201, 202	ERDS2TJ752T	1/4W 7.5K (GC)	R350	ERDS2TJ105T	1/4W 1M
R104	ERDS2TJ822T	1/4W 8.2K (GC)	R203, 204	ERDS2TJ473	1/4W 47K (E, EG)	R351	ERDS2TJ222	1/4W 2.2K
R105	ERDS2TJ471	1/4W 470	R203, 204	ERDS2TJ562T	1/4W 5.6K (GC)	R352	ERDS2TJ182	1/4W 1.8K
R106	ERDS2TJ474	1/4W 470K	R205, 206	ERDS2TJ331	1/4W 330 (E, EG)	R353, 354	ERDS2TJ102	1/4W 1K
R107	ERDS2TJ331	1/4W 330	R207, 208	ERDS2TJ271	1/4W 270 (E, EG)	R355, 356	ERDS2TJ104	1/4W 100K
R108	ERDS2TJ474	1/4W 470K	R209, 210	ERDS2TJ184T	1/4W 180K (E, EG)	R357	ERDS2TJ105T	1/4W 1M
R109	ERDS2TJ331	1/4W 330	R211, 212	ERDS2TJ123	1/4W 12K (E, EG)	R358	ERDS2TJ822	1/4W 8.2K
R110	ERDS2TJ102	1/4W 1K	R213, 214	ERDS2TJ680T	1/4W 68 (E, EG)	R359, 360	ERDS2TJ473	1/4W 47K
R112	ERDS2TJ104	1/4W 100K	R215, 216	ERDS2TJ272T	1/4W 2.7K (E, EG)	R361	ERDS2TJ102	1/4W 1K
R113	ERDS2TJ103	1/4W 10K	R217, 218	ERDS2TJ392T	1/4W 3.9K (E, EG)	R362	ERDS2TJ223	1/4W 22K
R114	ERDS2TJ562	1/4W 5.6K	R219, 220 Δ	ERDS1FVJ221T	1/2W 220 (E, EG)	R363, 364	ERDS2TJ473	1/4W 47K
R115	ERDS2TJ561	1/4W 560	R221, 222	ERDS2TJ752T	1/4W 7.5K	R365	ERDS2TJ102	1/4W 1K
R116	ERDS2TJ102	1/4W 1K	R223, 224	ERDS2TJ562	1/4W 5.6K	R371, 372	ERDS2TJ100	1/4W 10
R117	ERDS2TJ823T	1/4W 82K (E, EG)	R225, 226	ERDS2TJ472	1/4W 4.7K	R373, 374	ERDS2TJ224T	1/4W 220K
R117	ERDS2TJ273T	1/4W 27K (GC)	R227, 228	ERDS2TJ332	1/4W 3.3K	R375	ERDS2TJ103	1/4W 10K
R118	ERDS2TJ562	1/4W 5.6K	R229-231	ERDS2TJ222	1/4W 2.2K	R376	ERDS2TJ223	1/4W 22K
R119	ERDS2TJ822	1/4W 8.2K (E)	R233, 234	ERDS2TJ223	1/4W 22K	R378, 379	ERDS2EJ121	1/4W 120
R119	ERDS2TJ103T	1/4W 10K (EG)	R235, 236	ERDS2TJ822	1/4W 8.2K	R380	ERDS2TJ102	1/4W 1K
R119	ERDS2TJ682T	1/4W 6.8K (GC)	R237, 238	ERDS2TJ123	1/4W 12K	R381	ERDS2TJ223	1/4W 22K
R120	ERDS2TJ473	1/4W 47K	R239, 240	ERDS2TJ102	1/4W 1K	R382	ERDS2TJ105T	1/4W 1M
R121	ERDS2TJ332	1/4W 3.3K	R251, 252	ERDS2TJ222	1/4W 2.2K	R383	ERDS2TJ472	1/4W 4.7K
R122	ERDS2TJ272T	1/4W 2.7K	R253	ERDS2TJ223	1/4W 22K	R391, 392	ERDS2TJ222	1/4W 2.2K
R124	ERDS2TJ271	1/4W 270	R254	ERDS2TJ222	1/4W 2.2K	R393, 394	ERDS2TJ100	1/4W 10
R125, 126	ERDS2TJ152	1/4W 1.5K	R301, 302	ERDS2TJ222	1/4W 2.2K	R396	ERDS2TJ102	1/4W 1K
R127	ERDS2TJ103	1/4W 10K	R303	ERDS2TJ102	1/4W 1K	R397	ERDS2TJ150T	1/4W 15
R128	ERDS2TJ820	1/4W 82	R305, 306	ERDS2TJ223	1/4W 22K	R398	ERDS2TJ1R0	1/4W 1.0
R129	ERDS2TJ473	1/4W 47K	R307	ERDS2TJ822	1/4W 8.2K	R399	ERDS2TJ105T	1/4W 1M
R130	ERDS2TJ103	1/4W 10K	R308, 309	ERDS2TJ153	1/4W 15K	R451	ERDS2TJ102	1/4W 1K
R132	ERDS2TJ103	1/4W 10K	R310	ERDS2TJ182	1/4W 1.8K	R452	ERDS2TJ682T	1/4W 6.8K
R133-137	ERDS2TJ102	1/4W 1K	R315, 316	ERDS2TJ102	1/4W 1K	R453	ERDS2TJ123	1/4W 12K
R138	ERDS2TJ103	1/4W 10K	R317, 318	ERDS2TJ471	1/4W 470	R454	ERDS2TJ223	1/4W 22K
R139, 140	ERDS2TJ272T	1/4W 2.7K	R319, 320	ERDS2TJ103	1/4W 10K	R506	ERDS2TJ152	1/4W 1.5K
R141, 142	ERDS2TJ102	1/4W 1K	R323, 324	ERDS2TJ103	1/4W 10K	R507	ERDS2TJ331	1/4W 330
R143, 144	ERDS2TJ222	1/4W 2.2K	R325, 326	ERDS2TJ682T	1/4W 6.8K	R508, 509	ERDS2TJ473	1/4W 47K
R145, 146	ERDS2TJ821	1/4W 820 (E, EG)	R327, 328	ERDS2TJ182	1/4W 1.8K	R511, 512	ERDS2TJ103	1/4W 10K
R145, 146	ERDS2TJ102T	1/4W 1K (GC)	R329, 330	ERDS2TJ102	1/4W 1K	R550	ERDS2TJ564T	1/4W 560K (EG)
R147, 148	ERDS2TJ474	1/4W 470K	R331, 332	ERDS2TJ222	1/4W 2.2K	R551	ERDS2TJ223T	1/4W 22K (EG)
R149	ERDS2TJ680T	1/4W 68	R333	ERDS2TJ104	1/4W 100K	R552	ERDS2TJ103T	1/4W 10K (EG)
R171, 172	ERDS2TJ102	1/4W 1K	R334	ERDS2TJ102	1/4W 1K	R553	ERDS2TJ102T	1/4W 1K (EG)
R173	ERDS2TJ471	1/4W 470	R335	ERDS2TJ104	1/4W 100K	R555	ERDS2TJ104T	1/4W 100K (EG)
R175	ERDS2TJ102	1/4W 1K	R336	ERDS2TJ223	1/4W 22K	R556	ERDS2TJ332T	1/4W 3.3K (EG)
R176	ERDS2TJ391	1/4W 390	R337, 338	ERDS2TJ391	1/4W 390	R557, 558	ERDS2TJ102T	1/4W 1K (EG)
R177	ERDS2TJ472T	1/4W 4.7K (EG)	R339, 340	ERDS2TJ122	1/4W 1.2K	R559	ERDS2TJ562T	1/4W 5.6K (EG)
R191	ERDS2TJ103	1/4W 10K (E)	R341, 342	ERDS2TJ104	1/4W 100K	R560	ERDS2TJ820T	1/4W 82 (EG)
R192	ERDS2TJ122	1/4W 1.2K (E)	R343	ERDS2TJ105T	1/4W 1M	R562	ERDS2TJ473T	1/4W 47K (EG)

Ref. No.	Part No.	Values & Remarks	Ref. No.	Part No.	Values & Remarks	Ref. No.	Part No.	Values & Remarks
R563	ERDS2TJ332T	1/4W 3.3K (EG)	R837, 838	ERDS2TJ332	1/4W 3.3K	R943	ERDS2TJ223	1/4W 22K
R564	ERDS2TJ155T	1/4W 1.5M (EG)	R839, 840	ERDS2TJ103	1/4W 10K	R944	ERDS2TJ473	1/4W 47K
R565-567	ERDS2TJ332T	1/4W 3.3K (EG)	R841, 842	ERDS2TJ104	1/4W 100K	R945, 946	ERDS2TJ102	1/4W 1K
R568-571	ERDS2TJ101T	1/4W 100 (EG)	R843, 844	ERDS2TJ222	1/4W 2.2K	R947, 948	ERDS2TJ103	1/4W 10K
R573	ERDS2TJ471T	1/4W 470 (EG)	R845	ERDS2TJ182	1/4W 1.8K	R949	ERDS2TJ472	1/4W 4.7K
R574	ERDS2TJ103T	1/4W 10K (EG)	R846	ERDS2TJ391	1/4W 390	R950	ERDS2TJ102	1/4W 1K
R575, 576	ERDS2TJ102T	1/4W 1K (EG)	R847, 848	ERDS2TJ102	1/4W 1K	R951	ERDS2TJ104	1/4W 100K
R581	ERDS2TJ104	1/4W 100K	R849	ERDS2TJ391	1/4W 390	R952, 953	ERDS2TJ102	1/4W 1K
R582	ERDS2TJ102	1/4W 1K	R850	ERDS2TJ105T	1/4W 1M	R954	ERDS2TJ101	1/4W 100
R601, 602△	ERD2FCVJ4R7T	1/4W 4.7	R851, 852	ERDS2TJ102	1/4W 1K	R955	ERDS2TJ824	1/4W 820K
R603, 604	ERDS2TJ102	1/4W 1K	R853, 854	ERDS2TJ223	1/4W 22K	R956	ERDS2TJ101	1/4W 100
R605	ERDS2TJ101	1/4W 100	R855, 856	ERDS2TJ102	1/4W 1K	R957	ERDS2TJ102	1/4W 1K
R606, 607	ERDS2TJ393	1/4W 39K	R857, 858	ERDS2EJ121	1/4W 120	R958	ERDS2TJ471	1/4W 470
R609△	ERD2FCVJ4R7T	1/4W 4.7	R859	ERDS2TJ472	1/4W 4.7K	R959	ERDS2TJ103	1/4W 10K
R610	ERDS2TJ102	1/4W 1K	R860	ERDS2TJ182	1/4W 1.8K	R960	ERDS2TJ472	1/4W 4.7K
R612	ERDS2TJ472	1/4W 4.7K	R861	ERDS2TJ105T	1/4W 1M	R961	ERDS2TJ103	1/4W 10K
R613, 614	ERDS2TJ682T	1/4W 6.8K	R862	ERDS2TJ472	1/4W 4.7K	R962	ERDS2TJ473	1/4W 47K
R615	ERDS2TJ103	1/4W 10K	R863-865	ERDS2TJ473	1/4W 47K	R963	ERDS2TJ472	1/4W 4.7K
R616△	ERD25FVJ4R7T	1/4W 4.7	R866-868	ERDS2TJ102	1/4W 1K	R964	ERDS2TJ332	1/4W 3.3K
R621, 622	ERDS2TJ151	1/4W 150	R871, 872	ERDS2TJ4R7T	1/4W 4.7	R965	ERDS2TJ472	1/4W 4.7K
R623, 624	ERDS2TJ682T	1/4W 6.8K	R873△	ERD2FCVJ4R7T	1/4W 4.7	R966	ERDS2TJ123	1/4W 12K
R631-634	ERDS2TJ102	1/4W 1K	R874, 875	ERDS2TJ221	1/4W 220	R967	ERDS2TJ472	1/4W 4.7K
R635, 636	ERDS2TJ222	1/4W 2.2K	R876, 877	ERDS2TJ333	1/4W 33K	R968, 969	ERDS2TJ152	1/4W 1.5K
R637	ERDS2TJ100	1/4W 10	R901	ERDS2TJ821	1/4W 820	R971	ERDS2TJ104	1/4W 100K
R638	ERDS2TJ103	1/4W 10K	R902	ERDS2TJ102	1/4W 1K	R972	ERDS2TJ820	1/4W 82
R641, 642	ERDS2TJ471	1/4W 470	R903	ERDS2TJ122	1/4W 1.2K	R973	ERDS2TJ151	1/4W 150
R646	ERDS2TJ562	1/4W 5.6K	R904	ERDS2TJ152	1/4W 1.5K	R974, 975	ERDS2TJ473	1/4W 47K
R647	ERDS2TJ123	1/4W 12K	R905	ERDS2TJ182	1/4W 1.8K	R976	ERDS2TJ272T	1/4W 2.7K
R651-654	ERDS2TJ2R2T	1/4W 2.2	R906	ERDS2TJ222	1/4W 2.2K	R977	ERDS2TJ102	1/4W 1K
R655	ERDS2TJ102	1/4W 1K	R907	ERDS2TJ332	1/4W 3.3K	R978-992	ERDS2TJ104	1/4W 100K
R656	ERDS2TJ221	1/4W 220	R908	ERDS2TJ223	1/4W 22K	R993-995	ERDS2TJ102	1/4W 1K
R671	ERDS2TJ102	1/4W 1K	R909	ERDS2TJ103	1/4W 10K	R996	ERDS2TJ101	1/4W 100
R801, 802	ERDS2TJ392T	1/4W 3.9K	R910	ERDS2TJ821	1/4W 820	R997-999	ERDS2TJ102	1/4W 1K
R803-806	ERDS2TJ222	1/4W 2.2K	R911	ERDS2TJ102	1/4W 1K			CAPACITORS
R807, 808	ERDS2TJ104	1/4W 100K	R912	ERDS2TJ122	1/4W 1.2K	C101	ECBT1C103NS5	16V 0.01U
R809, 810	ERDS2TJ102	1/4W 1K	R913	ERDS2TJ152	1/4W 1.5K	C103	ECBT1C103NS5	16V 0.01U
R811	ERDS2TJ105T	1/4W 1M	R914	ERDS2TJ182	1/4W 1.8K	C104, 105	ECBT1H102KB5	50V 1000P
R813	ERDS2TJ472	1/4W 4.7K	R915	ERDS2TJ222	1/4W 2.2K	C106	ECBT1C103NS5	16V 0.01U
R814-816	ERDS2TJ332	1/4W 3.3K	R916-919	ERDS2TJ103	1/4W 10K	C107	ECBT1H473ZF5	50V 0.047U
R817	ERDS2TJ333	1/4W 33K	R920-922	ERDS2TJ102	1/4W 1K	C108	ECBT1H100JC5	50V 10P (E)
R818	ERDS2TJ183T	1/4W 18K	R923	ERDS2TJ391	1/4W 390	C108	ECBT1H8R2KC5	50V 8.2P (EG, GC)
R819, 820	ERDS2TJ102	1/4W 1K	R924	ERDS2TJ102	1/4W 1K	C109, 110	ECBT1C103NS5	16V 0.01U
R821	ERDS2TJ473	1/4W 47K	R925	ERDS2TJ221	1/4W 220	C111	ECEA1EKA4R7B	25V 4.7U
R822	ERDS2TJ274	1/4W 270K	R926	ERDS2TJ101	1/4W 100	C112	ECBT1C103NS5	16V 0.01U
R823	ERDS2TJ102	1/4W 1K	R927-933	ERDS2TJ102	1/4W 1K	C113	ECBT1H102KB5	50V 1000P
R824	ERDS2TJ105T	1/4W 1M	R934	ERDS2TJ101	1/4W 100	C114	RCE1HKA3R3BG	50V 3.3U
R828	ERDS2TJ222	1/4W 2.2K	R935	ERDS2TJ102	1/4W 1K	C115	ECEA1EKA4R7B	25V 4.7U
R829, 830	ERDS2TJ473	1/4W 47K	R936	ERDS2TJ101	1/4W 100	C116	ECBT1C822KS5	16V 8200P
R831	ERDS2TJ183T	1/4W 18K	R938	ERDS2TJ102	1/4W 1K	C117	ECQP1391JZ	100V 390P (E, EG)
R832	ERDS2TJ153	1/4W 15K	R939	ERDS2TJ101	1/4W 100	C117	ECQB1H102JF3	50V 1000P (GC)
R833, 834	ERDS2TJ333	1/4W 33K	R940, 941	ERDS2TJ393	1/4W 39K	C118, 119	ECFR1C103KR	16V 0.01U
R835, 836	ERDS2TJ222	1/4W 2.2K	R942	ERDS2TJ562	1/4W 5.6K			

Ref. No.	Part No.	Values & Remarks	Ref. No.	Part No.	Values & Remarks	Ref. No.	Part No.	Values & Remarks
C120, 121	ECEA1HKA010B	50V 1U	C319, 320	ECFR1C104KR	16V 0.1U	C605, 606	ECBT1E103ZF	25V 0.01U
C122	ECEA1HKA2R2B	50V 2.2U	C321	ECBT1E103ZF	25V 0.01U	C607	RCE1CKA100BG	16V 10U
C123	ECEA1HKA010B	50V 1U	C322	ECFR1C473KR	16V 0.047U	C608	RCE1CM101BV	16V 100U
C124	ECBT1H102KB5	50V 1000P	C323	ECFR1C103KR	16V 0.01U	C609	ECBT1H102KB5	50V 1000P
C125	ECBT1H150JC5	50V 15P	C335, 336	RCE1CKA100BG	16V 10U	C610, 611	ECBT1H104ZF5	50V 0.1U
C126	ECBT1H473ZF5	50V 0.047U	C337-340	ECEA1CKA220B	16V 22U	C612	RCE1EM471BV	25V 470U
C127	ECEA1CKA220B	16V 22U	C341, 342	ECEA1AKN100B	10V 10U	C613	ECBT1E103ZF	25V 0.01U
C128	ECBT1H102KB5	50V 1000P	C343	RCE1CKA100BG	16V 10U	C614	RCE1CKA100BG	16V 10U
C129, 130	ECEAOJKA101B	6.3V 100U	C344, 345	ECBT1H470J5	50V 47P	C615	ECEA1EKA101B	25V 100U
C132	ECBT1H102KB5	50V 1000P	C346	ECEA1HKA0R1B	50V 0.1U	C616	ECA1HM470B	50V 47U
C133, 134	ECBT1H270JU5	50V 27P	C347	ECEA1CN100SB	16V 10U	C617△	ECA1HM470B	50V 47U
C135, 136	ECBT1C103KS5	16V 0.01U	C348	ECEA1CKA330B	16V 33U	C618	ECA1JM470B	63V 47U
C137, 138	ECBT1H561KB5	50V 560P	C349	RCE1HKA3R3BG	50V 3.3U	C619	ECBT1E103ZF	25V 0.01U
C139, 140	ECBT1C682KR5	16V 6800P (E, EG)	C350	ECEAOJKA470B	6.3V 47U	C620	RCE1VKA100BG	35V 10U
C139, 140	ECBT1C562KR5	16V 5600P (GC)	C351, 352	RCE1CKA100BG	16V 10U	C622	RCE1VKA100BG	35V 10U
C141-144	ECEA1HKA010B	50V 1U	C353, 354	ECBT1H101KB5	50V 100P	C631-636	ECBT1H101KB5	50V 100P
C145	ECBT1H220JC5	50V 22P	C355	ECEA1CKA330B	16V 33U	C637	ECBT1H102KB5	50V 1000P
C148	ECBT1C103NS5	16V 0.01U	C356	ECBT1H104ZF5	50V 0.1U	C638	ECBT1H101KB5	50V 100P
C149	ECBT1H104ZF5	50V 0.1U	C357	RCE1CM101BV	16V 100U	C651, 652	ECBT1H104ZF5	50V 0.1U
C171, 172	ECBT1H102KB5	50V 1000P	C361, 362	ECBT1H221KB5	50V 220P	C653	ECBT1H102KB5	50V 1000P
C173	ECEA1CKA220B	16V 22U	C365	ECEAOJKA470B	6.3V 47U	C654	ECBT1H104ZF5	50V 0.1U
C174	RCE1CKA100BG	16V 10U	C391, 392	RCE1CM101BV	16V 100U	C655	RCE1CM101BV	16V 100U
C181	ECBT1H471KB5	50V 470P (E, EG)	C393, 394	ECBT1H102KB5	50V 1000P	C801	ECFR1C223KR	16V 0.022U
C196	ECBT1H102KB5	50V 1000P	C453	ECEA1HKA010B	50V 1U	C802	ECFR1E473KR	25V 0.047U
C201, 202	ECBT1H180J5	50V 18P (E, EG)	C455	RCE1CKA100BG	16V 10U	C803	ECEAOJKA221B	6.3V 220U
C201, 202	ECBT1H101KB5	50V 100P (GC)	C509	ECBT1E103ZF	25V 0.01U	C804-807	RCE1CKA100BG	16V 10U
C203, 204	ECBT1H151KB5	50V 150P (E, EG)	C510	RCE1AKA101BG	10V 100U	C808	ECEAOJKA221B	6.3V 220U
C205, 206	ECBT1H102KB5	50V 1000P (E, EG)	C550	ECEAOJKA101B	6.3V 100U (EG)	C809, 810	ECEA1HKA010B	50V 1U
C207, 208	RCE1AKA330BG	10V 33U (E, EG)	C551A	ECBT1H331KB5	50V 330P	C811, 812	ECQV1H104JM3	50V 0.1U
C209, 210	ECBTOJ223MS5	6.3V 0.022U (E, EG)	C551	ECEA1CKA220B	16V 22U (EG)	C813	RCE1HKA47BG	50V 0.47U
C211, 212	ECBT1C682KR5	16V 6800P (E, EG)	C552A	ECBT1H331KB5	50V 330P	C814	ECEA1VKA4R7B	35V 4.7U
C213, 214	RCE1CKA100BG	16V 10U (E, EG)	C552	RCE1CKA100BG	16V 10U (EG)	C815	RCE1HKA47BG	50V 0.47U
C215	ECBT1E103ZF	25V 0.01U (E, EG)	C553A	ECBT1E103ZF	25V 0.01U	C816	ECEA1VKA4R7B	35V 4.7U
C216	RCE1CM101BV	16V 100U (E, EG)	C553	ECEA1EKA4R7B	25V 4.7U (EG)	C817	ECEA1HKA15B	50V 0.15U
C217	ECBT1E103ZF	25V 0.01U (E, EG)	C554A	ECBT1E103ZF	25V 0.01U	C818	RCE1HKA3R3BG	50V 3.3U
C218	RCE1AKA101BG	10V 100U (E, EG)	C554	RCE1CKA100BG	50V 10U (EG)	C819, 820	ECQV1H154JM3	50V 0.15U
C219-222	ECBT1H101KB5	50V 100P	C555	ECEA1EKA4R7B	25V 4.7U (EG)	C821	RCE1HKA3R3BG	50V 3.3U
C223, 224	ECBT1H104ZF5	50V 0.1U	C557	ECBT1H102KB5	50V 1000P (EG)	C822	ECEA1HKA15B	50V 0.15U
C225-227	ECBT1H470J5	50V 47P	C558	ECEAOJKA101B	6.3V 100U (EG)	C823	ECEA1VKA4R7B	35V 4.7U
C231, 232	ECBT1E103ZF	25V 0.01U	C559, 560	ECEA1HKA010B	50V 1U (EG)	C824	RCE1HKA47BG	50V 0.47U
C233, 234	ECBT1H102KB5	50V 1000P	C561	ECFR1C223KR	16V 0.022U (EG)	C825	ECEA1VKA4R7B	35V 4.7U
C235, 236	ECBT1H101KB5	50V 100P	C562, 563	ECFR1C333KR	16V 0.033U (EG)	C826	RCE1HKA47BG	50V 0.47U
C251	RCE1CKA470BG	16V 47U	C564	ECBT1C332KR5	16V 3300P (EG)	C827, 828	ECQV1H104JM3	50V 0.1U
C301, 302	ECBT1H470J5	50V 47P	C565	ECBT1C682KR5	16V 6800P (EG)	C829	RCE1CKA470BG	16V 47U
C303	ECBT1E103ZF	25V 0.01U	C566	ECBT1C332KR5	16V 3300P (EG)	C830	ECQV1H474JM3	50V 0.47U
C304	ECFR1C473KR	16V 0.047U	C567	ECBT1C103KS5	16V 0.01U (EG)	C831	ECBA1H681KB5	50V 680P
C305, 306	RCE1CKA100BG	16V 10U	C568	ECBT1H102KB5	50V 1000P (EG)	C832	ECBT1H560J5	50V 56P
C307-310	ECFR1C104KR	16V 0.1U	C570	ECBT1H102KB5	50V 1000P (EG)	C833, 834	ECBT1H101KB5	50V 100P
C311, 312	ECFR1C123KR	16V 0.012U	C581, 582	ECBT1H104ZF5	50V 0.1U	C835	ECEA1HKA2R2B	50V 2.2U
C313, 314	ECFR1C153KR	16V 0.015U	C601, 602	ECKT1H23ZF	50V 0.022U	C836	ECEA1HKA010B	50V 1U
C315, 316	ECBT1C332KR5	16V 3300P	C603 △	ECA1EM222B	25V 2200U	C837	ECEA1CKA101B	16V 100U
C317, 318	ECEA1HKA15B	50V 0.15U	C604 △	RCE1EM471BV	25V 470U	C838	ECBT1E223ZF	25V 0.022U

1133

Cabinet Parts Location

