

Service Manual

Tuner

ST-HD350

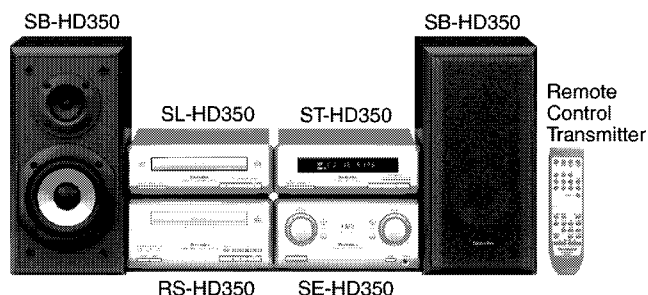

Colour

(N).....Gold Type

Area

(E).....Europe.

Because of unique interconnecting cables, when a component requires service, send or bring in the entire system.

System	SC-HD350
Tuner	ST-HD350
Amplifier	SE-HD350
CD Player	SL-HD350
Cassette Deck	RS-HD350
Speakers*	SB-HD350

*: Made in Spain.

Specifications

Pre-amplifier section

Input sensitivity/impedance:

EXT IN; 300 mV/15 k Ω

Tuner section

FM frequency range: 87.50 – 108.00 MHz
(0.05 MHz steps)

FM antenna terminal(s): 75 Ω (unbalanced)

AM frequency range: 522 – 1629 kHz (9 kHz steps)
520 – 1630 kHz (10 kHz steps)

Timer section

Clock:

Quartz - lock type

Function: Play timer (everyday), Rec timer (everyday),
Sleep (120 min, 30 min intervals)

General

Dimensions (W×H×D): 206×76.3×251 mm

Mass: 1.0 kg

Notes: Specifications are subject to change without notice.
Mass and dimensions are approximate.

⚠ WARNING

This service information is designed for experienced repair technicians only and is not designed for use by the general public. It does not contain warnings or cautions to advise non-technical individuals of potential dangers in attempting to service a product. Products powered by electricity should be serviced or repaired only by experienced professional technicians. Any attempt to service or repair the product or products dealt with in this service information by anyone else could result in serious injury or death.

Technics®

© 2001 Matsushita Electric Industrial Co., Ltd. All rights reserved. Unauthorized copying and distribution is a violation of law.

CONTENTS

	Page		Page
1 Note	2	7 Type Illustration of ICs, Transistors and Diodes	5
2 Before Repair	2	8 Schematic Diagram Notes	5
3 Location of Controls	2	9 Schematic Diagram	6
4 Operation Checks and Component Replacement Procedures	3	10 Printed Circuit Board Diagram	13
4.1. Checking for the FL P.C.B.	3	11 Wiring Connection Diagram	15
4.2. Checking for the main P.C.B.	3	12 Block Diagram	16
5 To Supply Power Source	3	13 Terminal Function of ICs	20
6 Self-Diagnostic Function	4	13.1. IC601 (C2BBGF000267):System Control/FL Drive	20
6.1. To display the malfunction code	4	14 Replacement Parts List	21
6.2. To return to the normal display	4	15 Cabinet Parts Location	24
6.3. Display contents	4		

1 Note

Refer to the service manual for Model No. SE-HD350 (Order No. AD0102036C2) for information on Accessories and Packaging.

2 Before Repair

This equipment (ST-HD350), which is a component of the system, is supplied with power from the Amplifier (SE-HD350). When repairing this equipment or checking operation of the system, be sure to connect to the amplifier with it.

Power supply and operation check in the state of it as a single equipment is impracticable.

3 Location of Controls

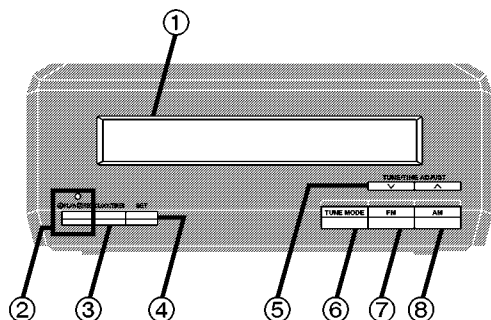

- ① **Display panel**
The display also shows information for the cassette deck, CD player, and amplifier.
- ② **Play timer/record timer button and indicator**
(⏮ PLAY/⏮ REC)
- ③ **Clock/timer button (CLOCK/TIMER)**
- ④ **Set button (SET)**
- ⑤ **Tuning/time adjust buttons**
(TUNE/TIME ADJUST ∇ , \blacktriangle)
- ⑥ **Tuning mode button (TUNE MODE)**
- ⑦ **FM band select button (FM)**
- ⑧ **AM band select button (AM)**

4 Operation Checks and Component Replacement Procedures

- This section describes procedures for checking the operation of the major printed circuit boards and replacing the main components.
- For reassembly after operation checks or replacement, reverse the respective procedures. Special reassembly procedures are described only when required.

4.1. Checking for the FL P.C.B.

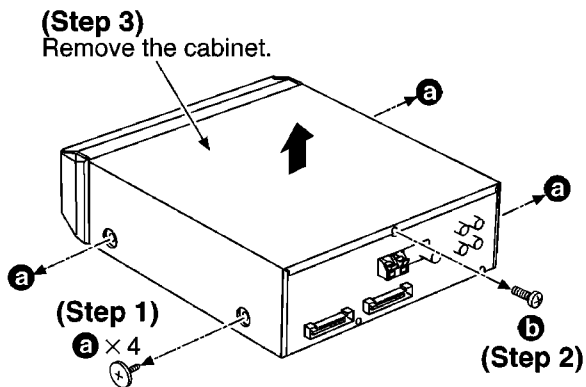

- Check the FL P.C.B. as shown below.

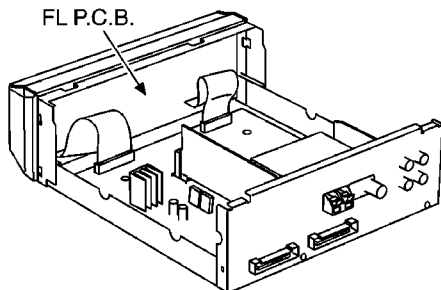

4.2. Checking for the main P.C.B.

- Follow the (Step 1) - (Step 3) of item 4.1.

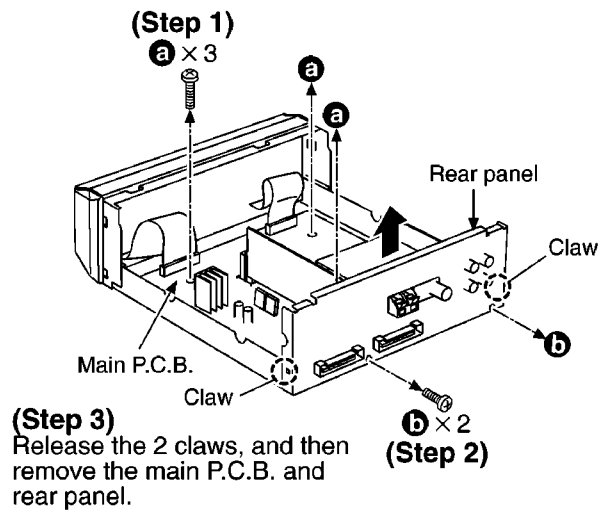

- Check the main P.C.B. as shown below.

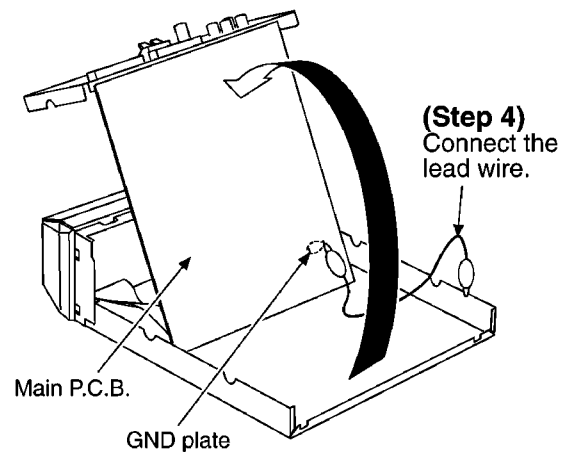

5 To Supply Power Source

This unit is designed to operate on power supplied from system connected.
 When a component requires service, use the system connections to supply power source.
 For system connections, refer to Fig. 5-1.

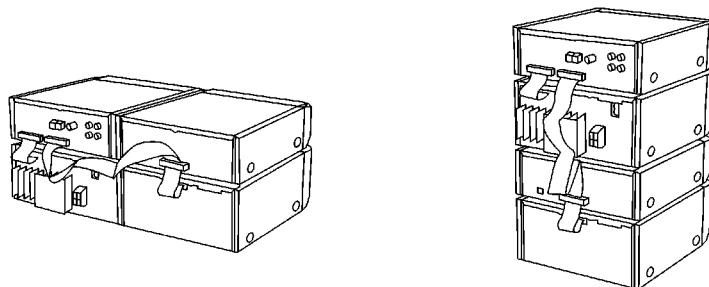

Fig. 5-1.

6 Self-Diagnostic Function

This unit is equipped with a self-diagnostic function which, in the event of a malfunction, automatically displays a code indicating the nature of the malfunction.

Use this self-diagnostic function when servicing the unit.

6.1. To display the malfunction code

- U70 CD:** Automatically displays on the tuner when a malfunction occurs. Refer to Fig. 6-1.
U70 TAPE: Automatically displays on the tuner when a malfunction occurs. Refer to Fig. 6-1.
F61: Automatically displays on the tuner when a malfunction occurs. Refer to Fig. 6-1.

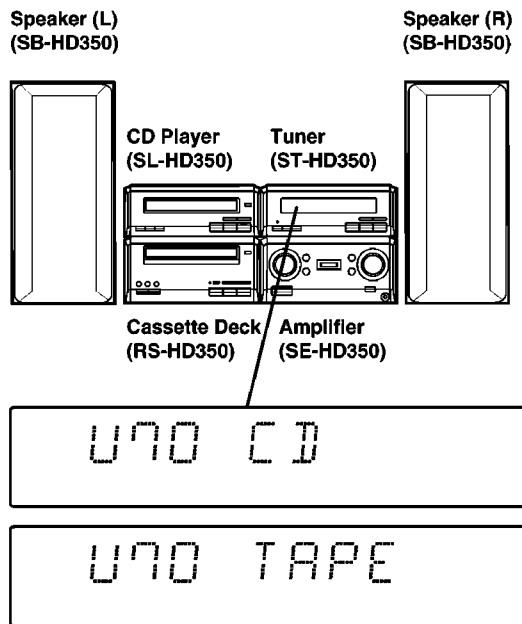

Fig. 6-1.

6.2. To return to the normal display

1. For U70 CD/U70 TAPE

- Press any operation button on the tuner.
- To re-display the code, switch the power off (POWER STANDBY button), and then switch power back on again.

2. For F61

- If F61 is displayed, the power will automatically be switched off.
- F61 will be displayed for 3 seconds, and then the clock will be displayed.
- To re-display the code, switch the power on. F61 will be re-displayed, and then after 3 seconds the clock will be displayed and the power will automatically switch off.

6.3. Display contents

6.3.1. U70 CD/U70 TAPE (displayed automatically)

• Problem or condition

A bus-line communications error has occurred as a result of the flat cables being inserted incorrectly, thus preventing the system from operating.

- If U70 is displayed on the tuner, the CD Player or Cassette deck cannot be operated by remote control.

• Correction Procedure

1. To check for correct insertion of the flat cables.
 - Insert each connector until you hear a click.
 - Insert the flat cables at the back of the unit in the order indicated. Refer to Fig. 6-2.

Make sure the white side of the cable is on your right side. Refer to Fig. 6-3.

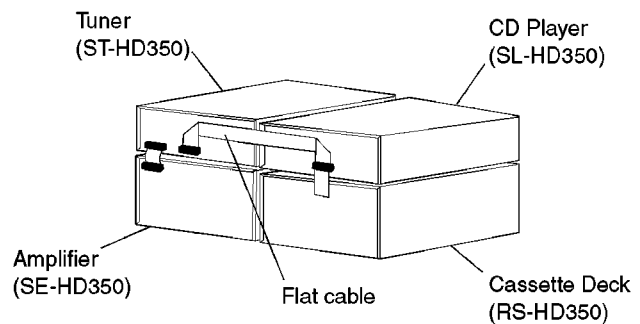

Fig. 6-2.

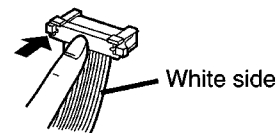

Fig. 6-3.

2. Breakage of the flat cables. (Check and replace.)
3. If the problem is not corrected by items 1 and 2 above, this indicates a faulty IC.

ST-HD350:

IC601 (C2BBGF000267)

SL-HD350:

IC201 (C2BBFD000248)

RS-HD350:

IC701 (C2BBED000031)

Check these ICs and replace.

6.3.2. F61

• Problem or condition

When the power switch is switched on, it automatically switches back off, making it impossible to switch power on.

• Correction procedure

Faulty the Amplifier (SE-HD350) output IC (IC101). (When a DC voltage is applied to speaker terminals.)

7 Type Illustration of ICs, Transistors and Diodes

	<table border="1"> <tr><td>BR93LC46FERR</td><td>8PIN</td></tr> <tr><td>BU4052BCF-E2</td><td>16PIN</td></tr> <tr><td>C1BB00000528</td><td>20PIN</td></tr> <tr><td>M5218AFPE3</td><td>8PIN</td></tr> </table>	BR93LC46FERR	8PIN	BU4052BCF-E2	16PIN	C1BB00000528	20PIN	M5218AFPE3	8PIN	<p>C2BBGF000201</p>	<p>2SB1417PQTA 2SD2137PQTA</p>	<p>2SD2144STA DTA114ESTP DTA114TSTP DTC114ESTP DTC143XSTP</p>	
BR93LC46FERR	8PIN												
BU4052BCF-E2	16PIN												
C1BB00000528	20PIN												
M5218AFPE3	8PIN												
<p>2SA1309ATA 2SC3311ATA</p>	<p>2SD1819ATX UN5214TX</p>	<p>2SC3940AQSTA</p>	<p>2SD2374PQAU</p>	<p>2SB621AQRSTA</p>	<p>MA111TX 1SS380TE-17</p>								
<p>MA719TA</p>	<p>MA4051MTA MA4056HTA MA4062HTA MA4082LTA MA4091MTA</p>		<p>MA165TA MA29WATA</p>	<p>MA8062MTX MA8051MTX</p>	<p>RL1N4003N02</p>								
<p>LNJ201LPQJA</p>													

8 Schematic Diagram Notes

- This schematic diagram may be modified at any time with the development of new technology.

Notes:

S601:	Tuning/time adjust up switch (TUNE/TIME ADJUST \wedge)
S602:	Tuning/time adjust down switch (TUNE/TIME ADJUST \vee)
S603:	Play timer/record timer switch (\odot PLAY/ \ominus REC)
S604:	Clock/timer switch (CLOCK/TIMER)
S605:	Set switch (SET)
S606:	Tuning mode switch (TUNE MODE)
S607:	FM band select switch (FM)
S608:	AM band select switch (AM)

- Indicated voltage values are the standard values for the unit measured by the DC electronic circuit tester (high-impedance) with the chassis taken as standard. Therefore, there may exist some errors in the voltage values, depending on the internal impedance of the DC circuit tester.

No mark : FM
() : AM

- Important safety notice:

Components identified by \triangle mark have special characteristics important for safety.

Furthermore, special parts which have purposes of fire-

retardant (resistors), high-quality sound (capacitors), low-noise (resistors), etc. are used.

When replacing any of components, be sure to use only manufacturer's specified parts shown in the parts list.

- The supply part number is described alone in the replacement parts list.

Caution!

IC and LSI are sensitive to static electricity.

Secondary trouble can be prevented by taking care during repair.

Cover the parts boxes made of plastics with aluminum foil.

Ground the soldering iron.

Put a conductive mat on the work table.

Do not touch the legs of IC or LSI with the fingers directly.

- Voltage and signal line

	: Positive voltage line
	: Negative voltage line
	: FM signal line
	: FM OSC signal line
	: AM signal line
	: AM OSC signal line
	: FM/AM signal line

9 Schematic Diagram

SCHEMATIC DIAGRAM-1

NOTE:
 The number which noted at the connectors on the schematic diagram as "SCHEMATIC DIAGRAM-1" or "SCHEMATIC DIAGRAM-2" indicates the schematic diagram serial number located on the left corner in the schematic diagram.

—: POSITIVE VOLTAGE LINE
 - - - : NEGATIVE VOLTAGE LINE

A FL CIRCUIT

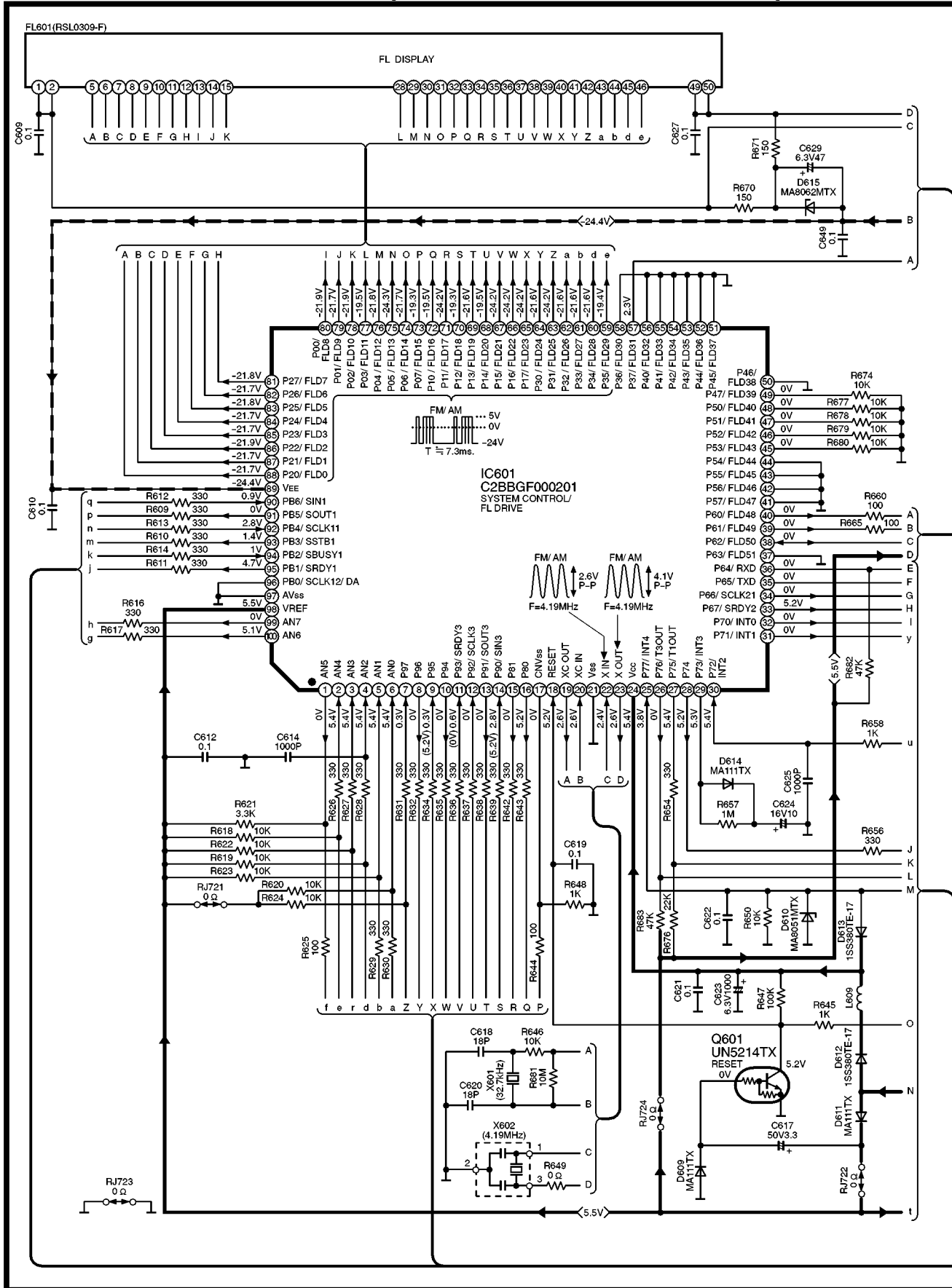

SCHEMATIC DIAGRAM-2

B OPERATION CIRCUIT

→ : POSITIVE VOLTAGE LINE -> : NEGATIVE VOLTAGE LINE

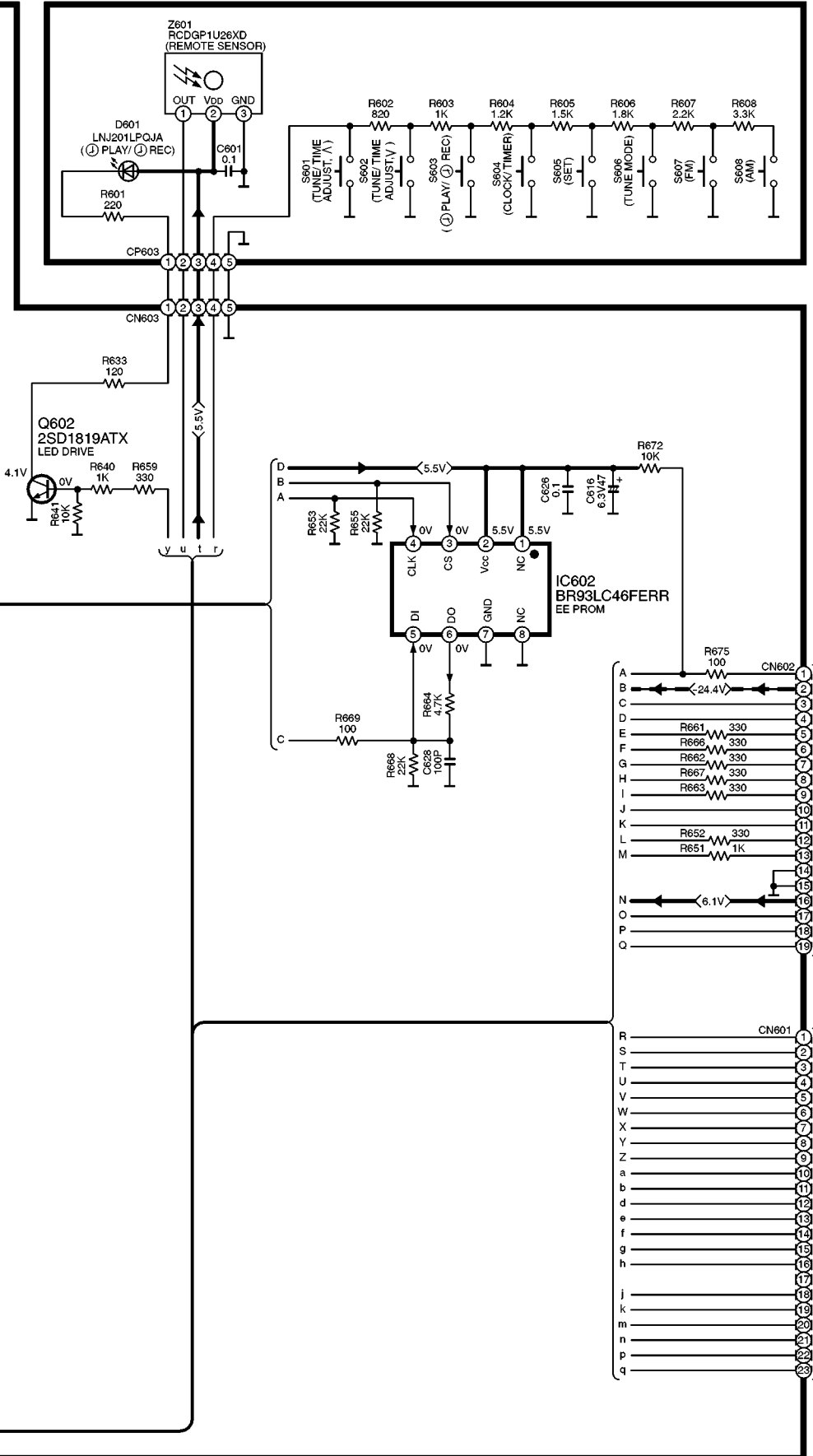

SCHEMATIC DIAGRAM-3

C MAIN CIRCUIT

→ : POSITIVE VOLTAGE LINE - - - - - : NEGATIVE VOLTAGE LINE ⇨ : FM/AM SIGNAL LINE

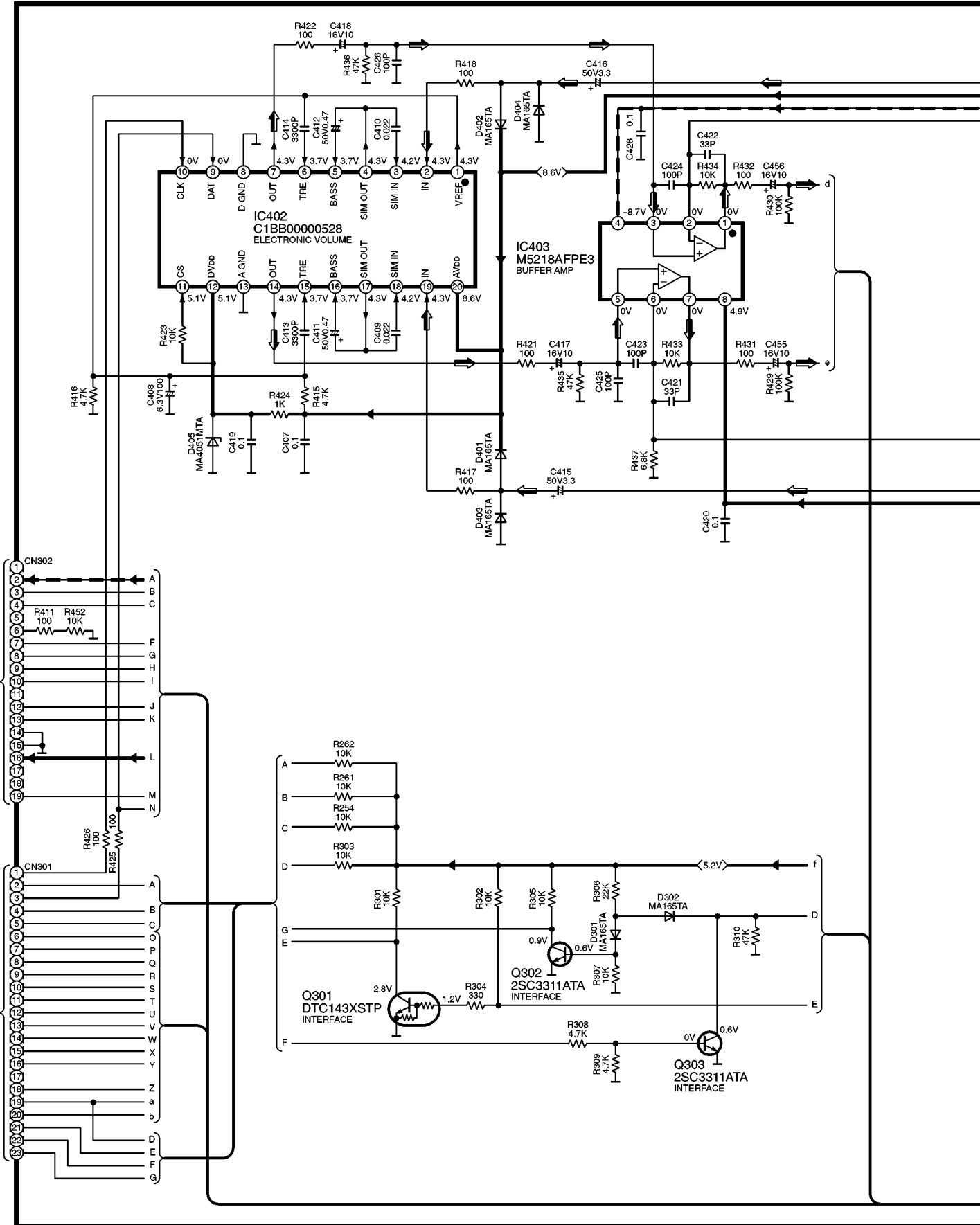

SCHEMATIC DIAGRAM-4

→ : POSITIVE VOLTAGE LINE - - - - - : NEGATIVE VOLTAGE LINE ⇨ : FM/AM SIGNAL LINE

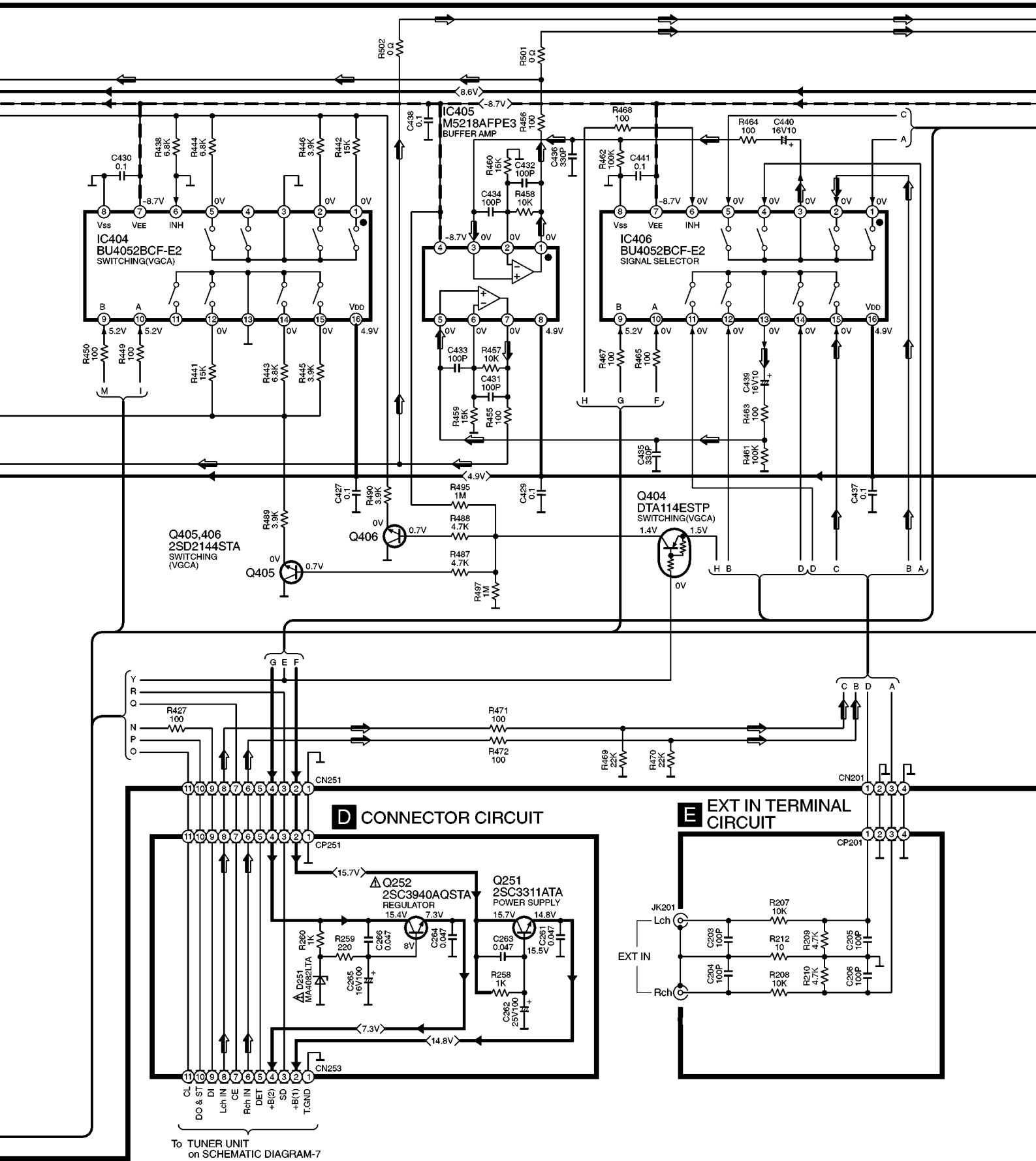

SCHMATIC DIAGRAM-5

C MAIN CIRCUIT

→ : POSITIVE VOLTAGE LINE → - : NEGATIVE VOLTAGE LINE ⇨ : FM/AM SIGNAL LINE

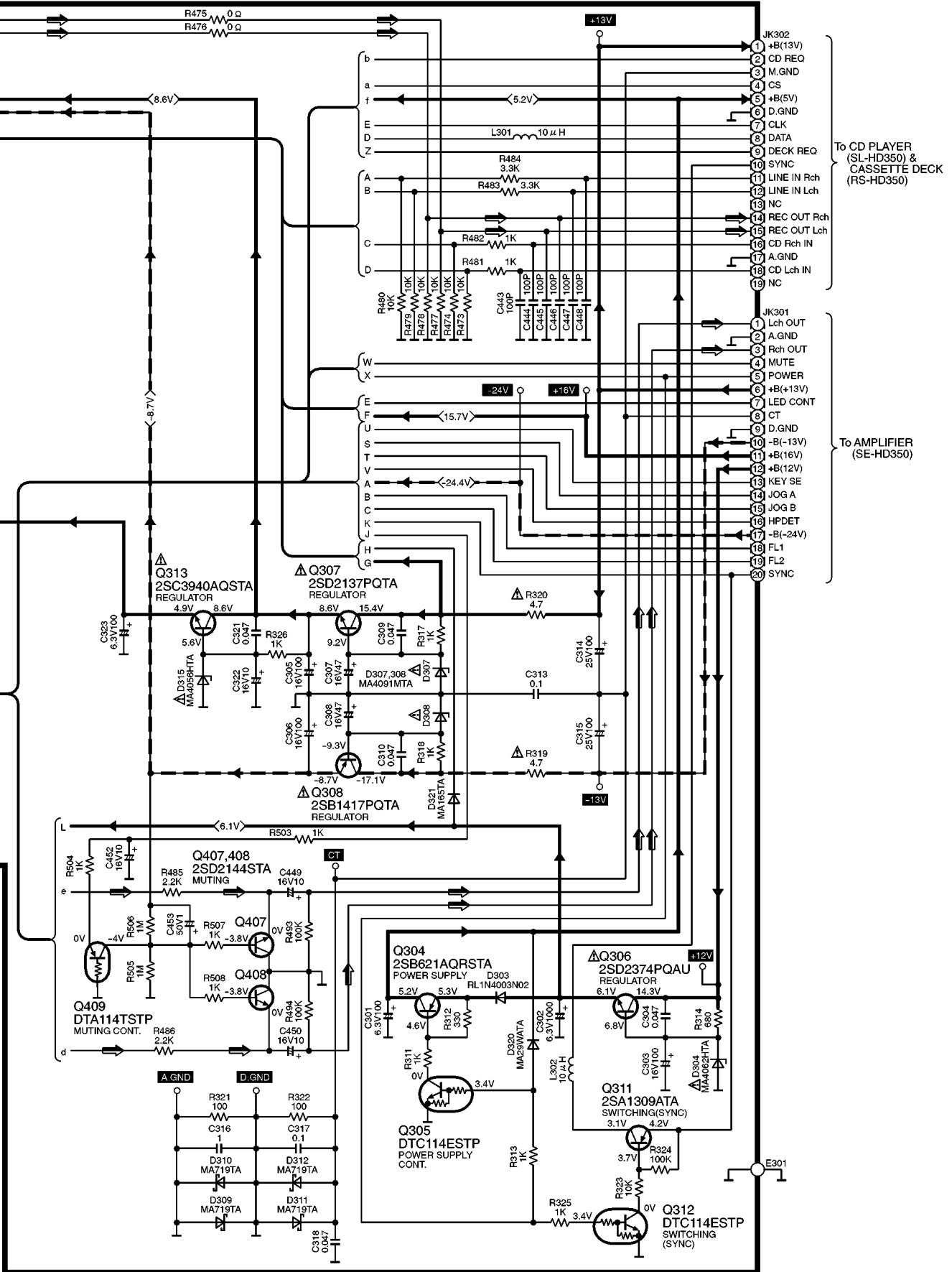

SCHEMATIC DIAGRAM-6

Z101 TUNER UNIT(RAN0005EM-2)

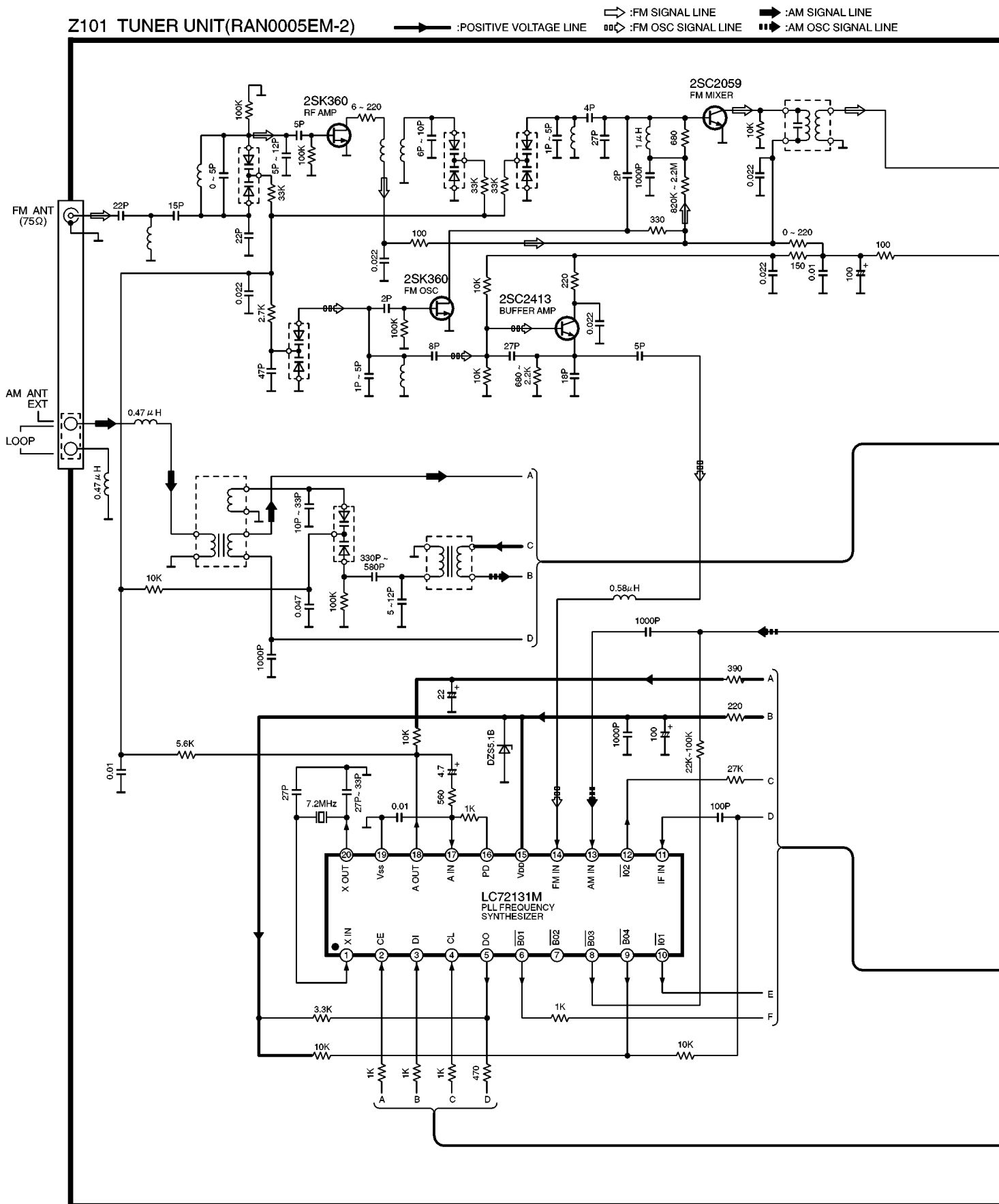

SCHEMATIC DIAGRAM-7

: POSITIVE VOLTAGE LINE
 : FM SIGNAL LINE
 : FM/ AM SIGNAL LINE
 : AM SIGNAL LINE
 : AM OSC SIGNAL LINE

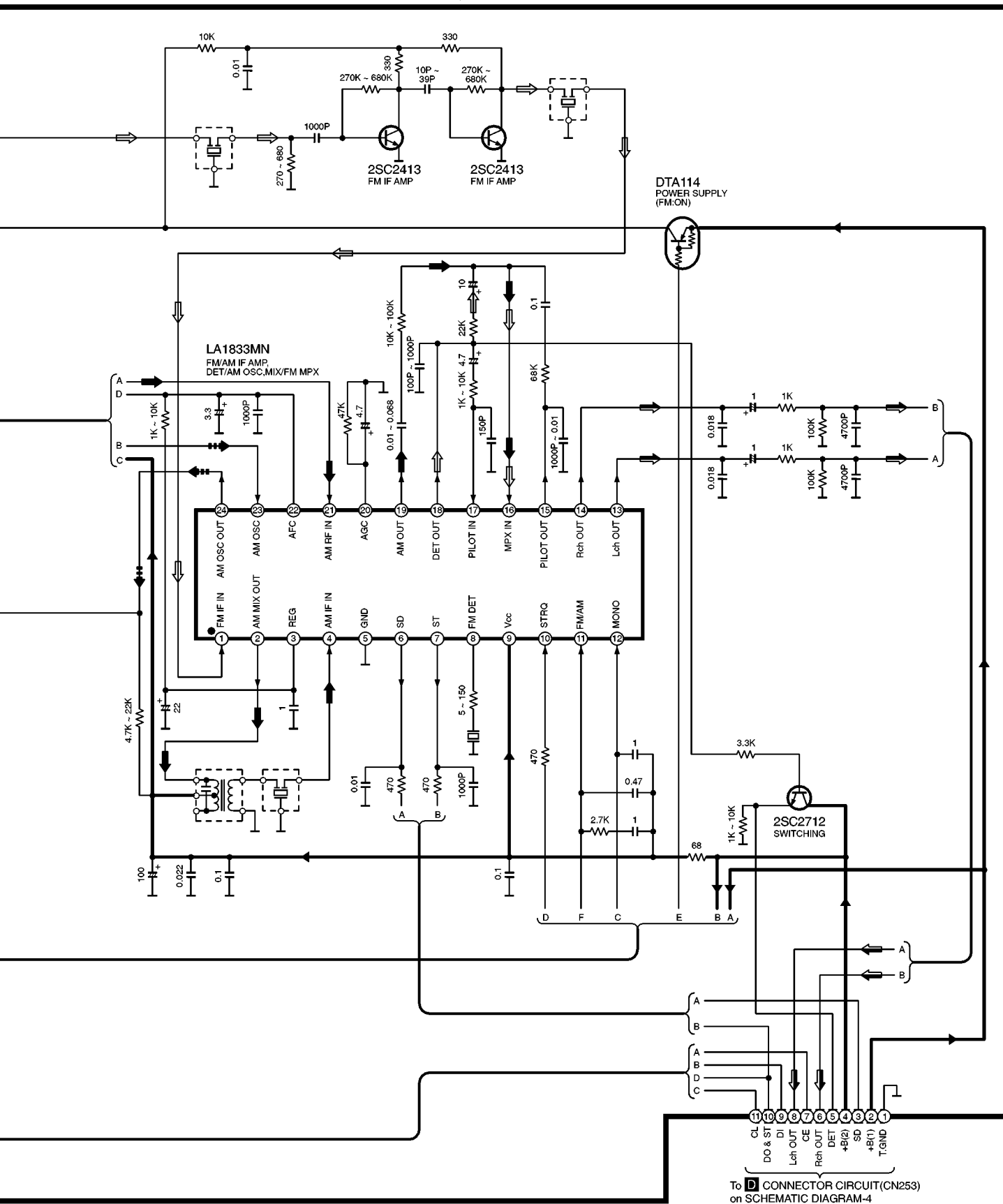

To **D** CONNECTOR CIRCUIT(CN253) on SCHEMATIC DIAGRAM-4

10 Printed Circuit Board Diagram

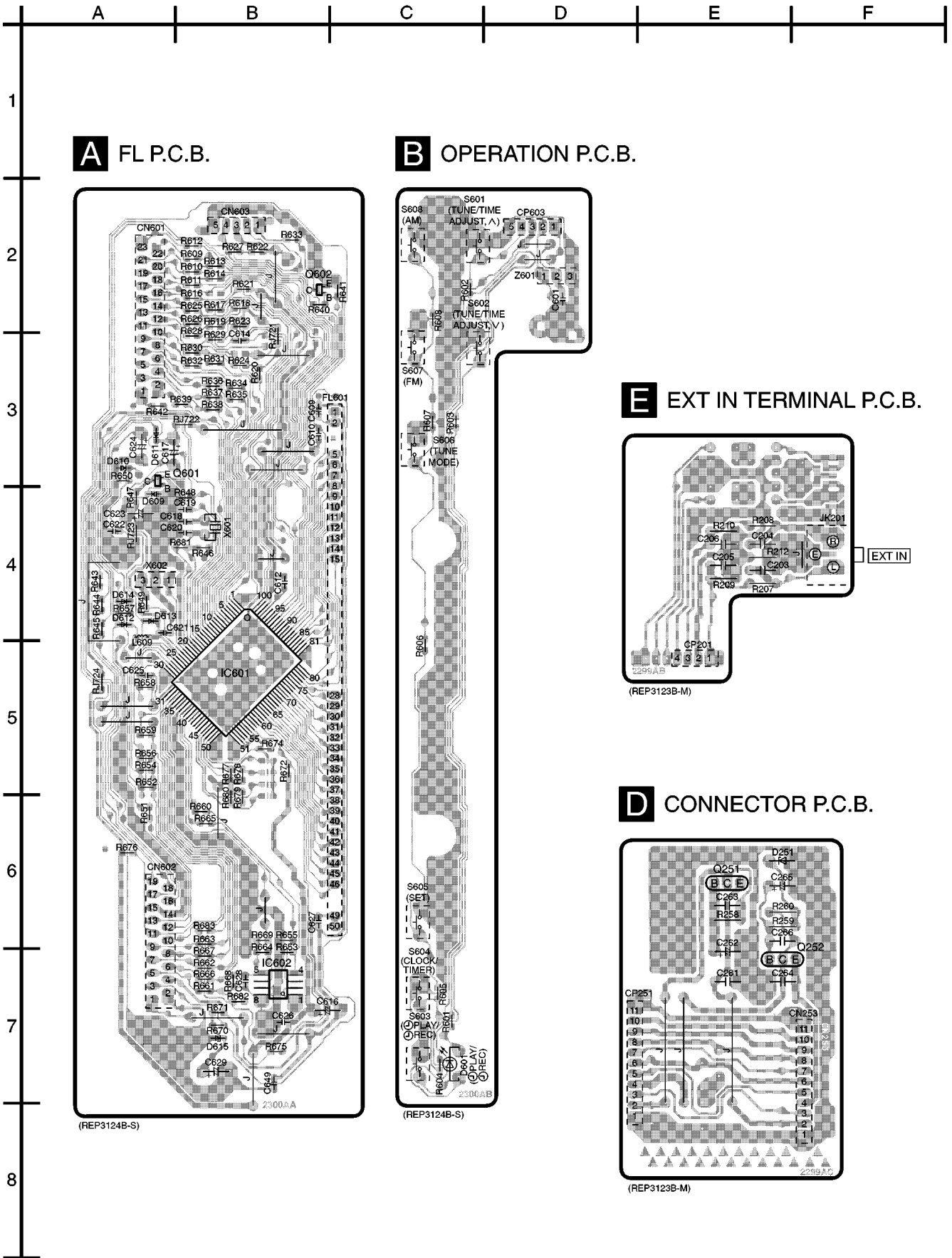

A B C D E F

C MAIN P.C.B.

To CD PLAYER & CASSETTE DECK

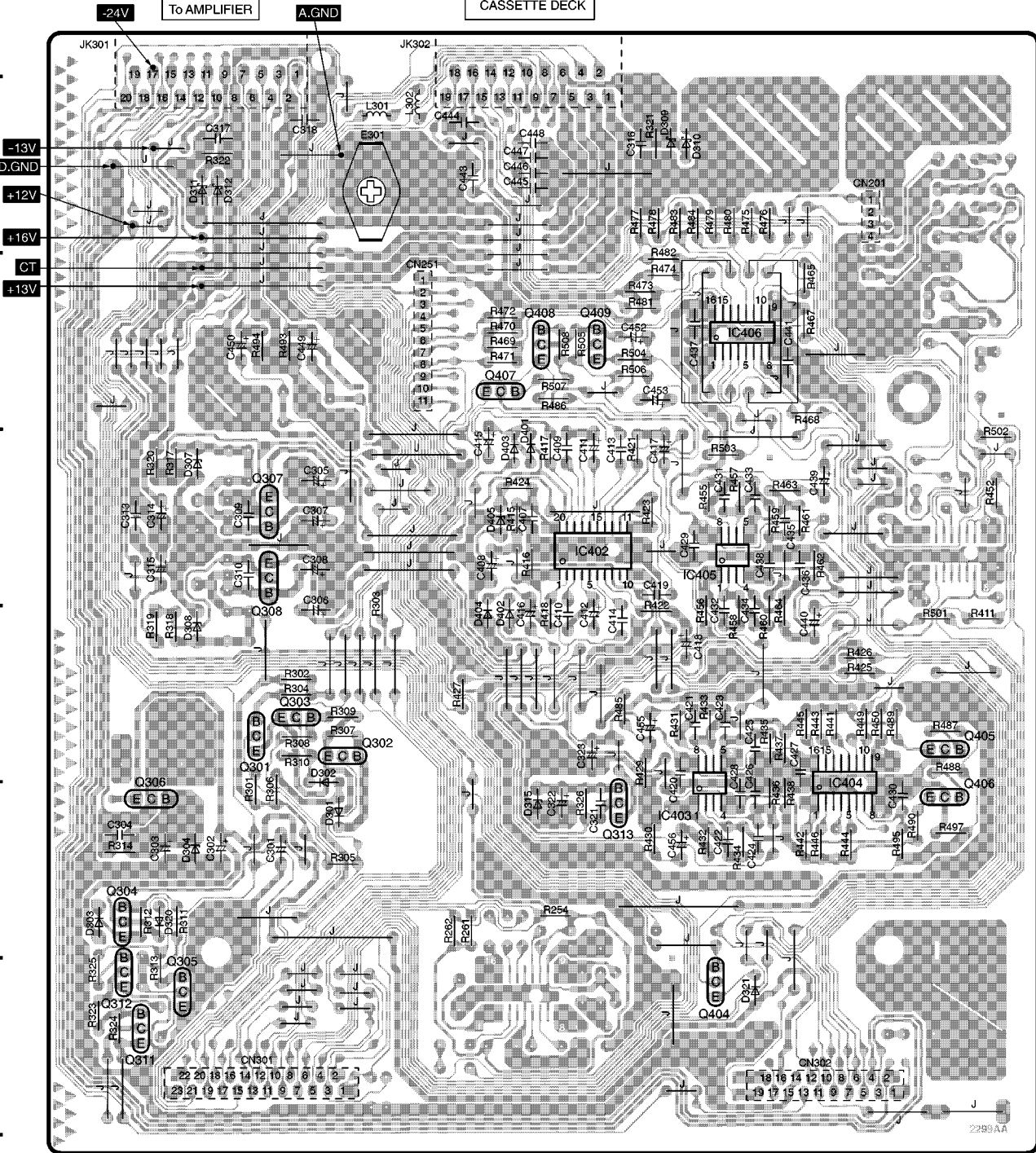

(REP3123B-M)

2293AA

11 Wiring Connection Diagram

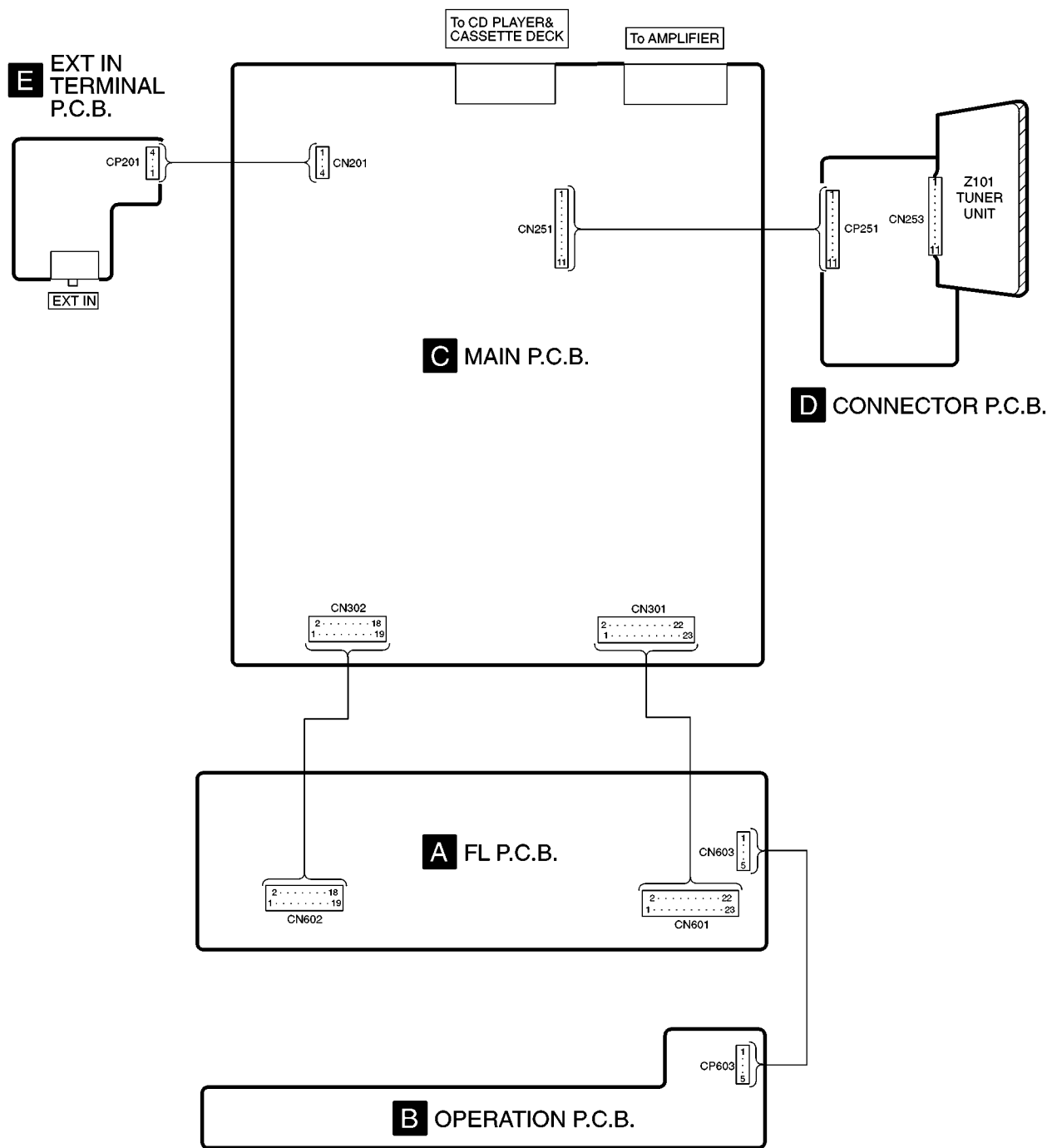

12 Block Diagram



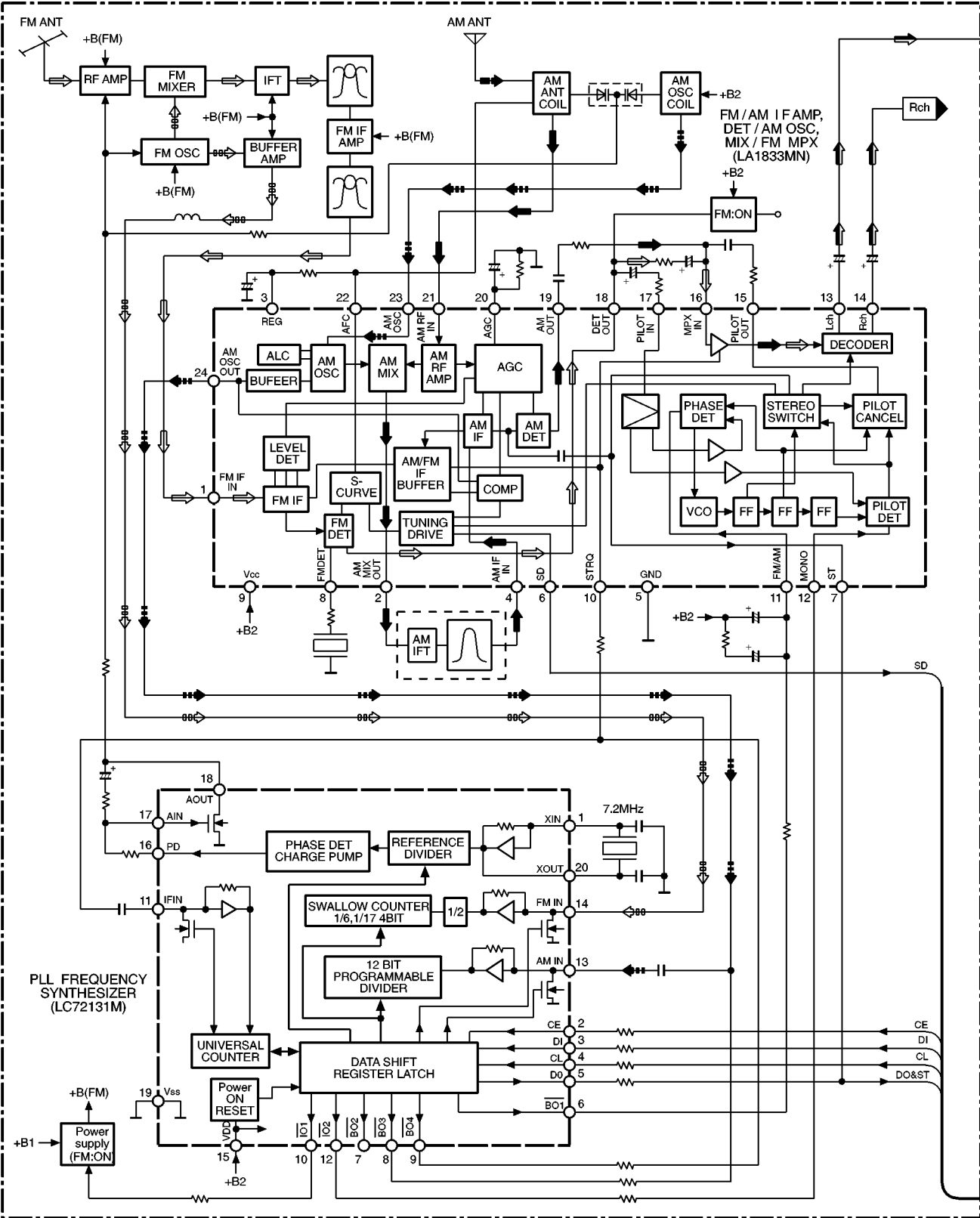

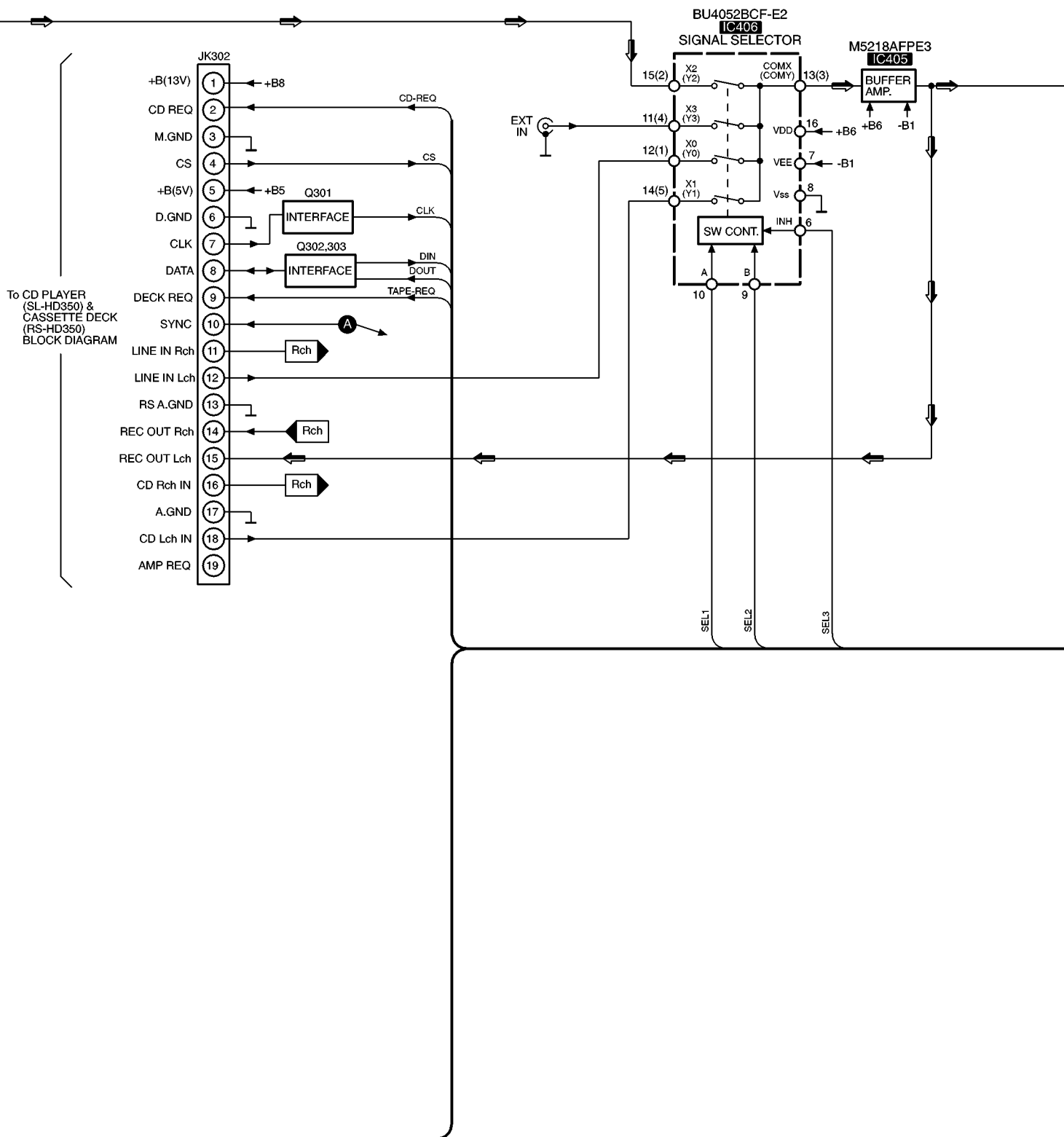
Z101 TUNER UNIT (RAN0005EM-2)

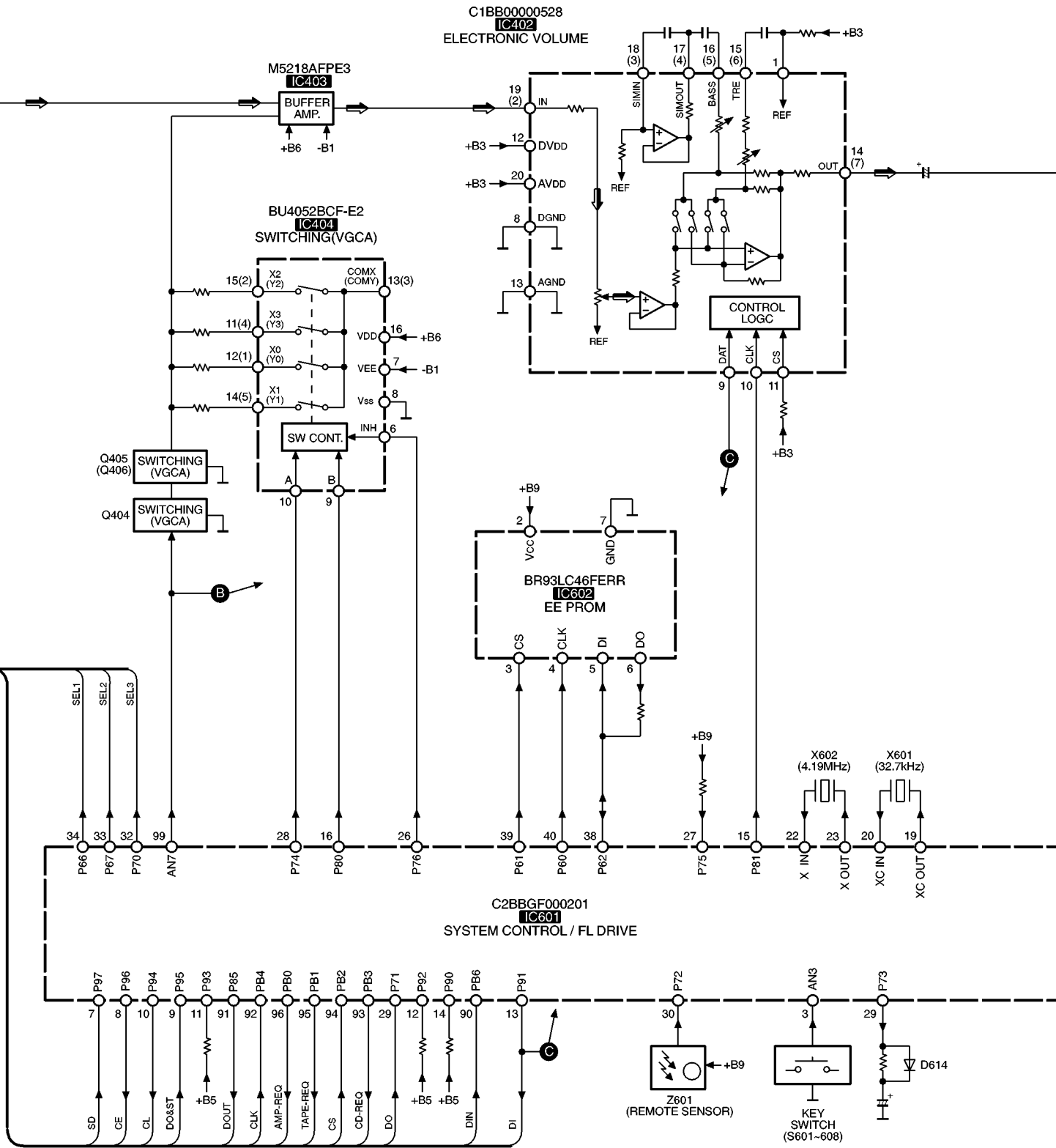





NOTE

-  : FM SIGNAL LINE
-  : FM OSC SIGNAL LINE
-  : AM SIGNAL LINE
-  : AM OSC SIGNAL LINE
-  : FM/AM SIGNAL LINE
- () indicates pin No. Right channel.

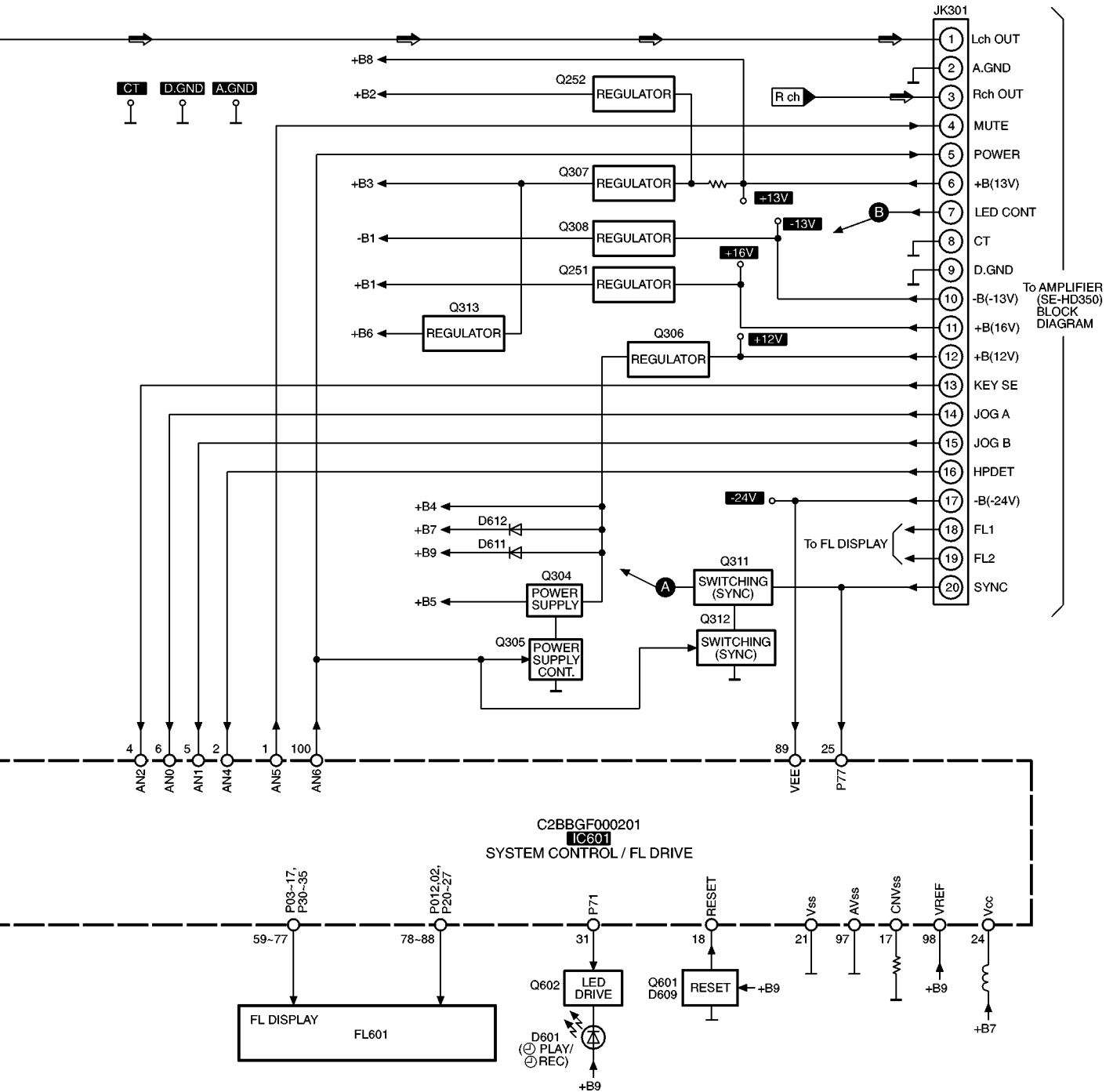

13 Terminal Function of ICs

13.1. IC601 (C2BBGF000267): System Control/FL Drive

Pin No.	Terminal Name	I/O	Function
1	AN5	O	Muting signal output
2	AN4	I	Headphone connection detect signal input
3	AN3	I	Key switch signal input
4	AN2	I	Key switch signal input from Amplifier
5	AN1	I	Selector switch signal input from Amplifier
6	AN0	I	Volume switch signal input from Amplifier
7	P97	I	Tuner signal detection input from Z101
8	P96	O	Chip enable signal output for Z101
9	P95	I	Data signal input from Z101
10	P94	O	Clock signal output for Z101
11	P93/ SRDY3	I	Connected to V_{CC}
12	P92/ SCLK3	I	Connected to V_{CC}
13	P91/ SOUT3	O	Control data signal output for IC402
14	P90/ SIN3	I	Connected to V_{CC}
15	P81	O	Clock signal output for serial data transfer
16	P80	O	VGCA switch control signal output
17	CNV _{SS}	-	GND terminal
18	RESET	I	Reset signal input
19	XC OUT	O	Oscillator connected terminal (F=32.7 kHz)
20	XC IN	I	
21	V _{SS}	-	GND terminal
22	X IN	I	Oscillator connected terminal (F=4.19 MHz)
23	X OUT	O	
24	V _{CC}	I	Power supply terminal
25	P77/ INT4	I	Power failure detect signal input
26	P76/ T3OUT	O	Muting signal output
27	P75/ T1OUT	-	Not used, connected to VREF
28	P74	O	VGCA switch control signal output
29	P73/ INT3	O	CR timer terminal for clock backup
30	P72/ INT2	I	Remote control signal input
31	P71/ INT1	O	LED drive signal output
32	P70/ INT0	O	Select signal output for IC406
33	P67/ SRDY2	O	Select signal output for IC406
34	P66/ SCLK21	O	Select signal output for IC406
35	P65/ TXD	-	Not used, connected to GND
36	P64/ RXD	-	Not used, connected to VREF
37	P63/ FLD51	-	GND terminal
38	P62/ FLD50	I/O	Data signal input/output
39	P61/ FLD49	O	Chip select signal output
40	P60/ FLD48	O	Clock signal output
41	P57/ FLD47	-	Not used, connected to GND
44	P54/ FLD44		

Pin No.	Terminal Name	I/O	Function
45	P53/ FLD43	-	Not used, connected to GND
56	P40/ FLD32		
57	P37/ FLD31	-	Not used, connected to VREF
58	P36/ FLD30	-	Not used, connected to GND
59	P35/ FLD29	O	FL segment control signal output
77	P03/ FLD11		
78	P02/ FLD10	O	FL grid control signal output
88	P20/ FLD0		
89	V _{EE}	I	Power supply terminal (Negative)
90	PB6/ SIN1	I	Communication data signal input
91	PB5/ SOUT1	O	Communication data signal output
92	PB4/ SCLK11	I	Communication clock signal input
93	PB3/ SSTB1	O	Communication request signal output for CD
94	PB2/ SBUSY1	I	Communication chip select signal input
95	PB1/ SRDY1	O	Communication request signal output for Deck
96	PB0/ SCLK12/ DA	-	Not used, connected to GND
97	AV _{SS}	-	GND terminal
98	VREF	I	Reference voltage input
99	AN7	O	LED (VGCA) control signal output
100	AN6	O	Power supply control signal output

14 Replacement Parts List

Notes:

- Important safety notice:

Components identified by Δ mark have special characteristics important for safety.

Furthermore, special parts which have purposes of fire-retardant (resistors), high-quality sound (capacitors), low-noise (resistors), etc. are used.

When replacing any of components, be sure to use only manufacture's specified parts shown in the parts list.

- The marking [RTL] indicates that Retention Time is Limited for this item. After the discontinuation of this assembly in production, the item will continue to be available for a specific period of time. The retention period of availability is dependent on the type of assembly, and in accordance with the laws governing part and product retention. After the end of this period, the assembly will no longer be available.

- All parts are supplied by MESA.

Ref. No.	Part No.	Part Name & Description	Pcs	Remarks
1	RHD30007-1S	SCREW	4	
2	RKM0413B-N	CABINET	1	
3	XTB3+8JFZ	SCREW	1	
4	REZ1379	FFC (23P)	1	
5	RKA0114-K	FOOT	4	
5-1	RKA0083-K	CUSHION	4	
6	REZ1359	FFC (19P)	1	
7	RGG0189B-S	MAIN PANEL	1	
8	RAN0005EM-2	TUNER UNIT	1	
9	RGF0841-S	SUB PANEL	1	
10	RGU1935A-S	BUTTON, BAND	1	
11	RGU1939-S	BUTTON, TIMER	1	
12	RKW0629-R	FL WINDOW	1	
13	XTBS26+8J	SCREW	9	
14	XTBS3+8JFZ1	SCREW	9	
15	XTB3+12JFZ	SCREW	3	
16	XTB3+5JFZ	SCREW	4	
17	RGK1335-S	SIDE PLATE (L)	1	
18	RGK1336-S	SIDE PLATE (R)	1	
19	RGL0529-Q	INDICATOR, TIMER	1	
20	SHE170-2	P.C.B. SUPPORT	4	
C203-06	ECBT1H101KB5	50V 100P	4	F1D1H101A012
C261	ECBT1H473KB5	50V 0.047U	1	
C262	ECALEAM101XB	25V 100U	1	
C263,64	ECBT1H473KB5	50V 0.047U	2	
C265	ECA1CAK101XB	16V 100U	1	
C266	ECBT1H473KB5	50V 0.047U	1	
C301	ECA0JAK101XB	6.3V 100U	1	
C302	ECA0JAML02XB	6.3V 1000U	1	
C303	ECA1CAK101XB	16V 100U	1	
C304	ECBT1H473KB5	50V 0.047U	1	
C305,06	ECA1CAK101XB	16V 100U	2	
C307,08	ECA1CAK470XB	16V 47U	2	
C309,10	ECBT1H473KB5	50V 0.047U	2	
C313	ECBT1H104ZF5	50V 0.1U	1	F1E1H104A001
C314,15	ECALEAM101XB	25V 100U	2	
C316	ECBT1C105ZF5	16V 1U	1	F1E1C1050001
C317	ECBT1H104ZF5	50V 0.1U	1	F1E1H104A001
C318	ECBT1H473KB5	50V 0.047U	1	
C321	ECBT1H473KB5	50V 0.047U	1	
C322	ECA1CAK100XB	16V 10U	1	
C323	ECA0JAK101XB	6.3V 100U	1	
C407	ECBT1H104ZF5	50V 0.1U	1	F1E1H104A001
C408	ECA0JAK101XB	6.3V 100U	1	
C409,10	ECQB1H223JF3	50V 0.022U	2	

Ref. No.	Part No.	Part Name & Description	Pcs	Remarks
C411,12	ECA1HAKR47XB	50V 0.47U	2	
C413,14	ECBT1C332KR5	16V 3300P	2	
C415,16	RCE1HKA3R3BG	50V 3.3U	2	F2A1H3R3A015
C417,18	ECA1CAK100XB	16V 10U	2	
C419,20	ECBT1H104ZF5	50V 0.1U	2	F1E1H104A001
C421,22	ECBT1H330J5	50V 33P	2	F1D1H330A006
C423-26	ECBT1H101KB5	50V 100P	4	F1D1H101A012
C427-30	ECBT1H104ZF5	50V 0.1U	4	F1E1H104A001
C431-34	ECBT1H101KB5	50V 100P	4	F1D1H101A012
C435,36	ECBT1H331KB5	50V 330P	2	F1D1H331A012
C437,38	ECBT1H104ZF5	50V 0.1U	2	F1E1H104A001
C439,40	ECA1CAK100XB	16V 10U	2	
C441	ECBT1H104ZF5	50V 0.1U	1	F1E1H104A001
C443-48	ECBT1H101KB5	50V 100P	6	F1D1H101A012
C449,50	ECA1CAK100XB	16V 10U	2	
C452	ECA1CAK100XB	16V 10U	1	
C453	ECA1HAK010XI	50V 1U	1	ECA1HAK010XB
C455,56	ECA1CAK100XB	16V 10U	2	
C601	ECUV1H104ZFN	50V 0.1U	1	
C609,10	ECUV1H104ZFN	50V 0.1U	2	
C612	ECUV1H104ZFN	50V 0.1U	1	
C614	ECUV1H102KBN	50V 1000P	1	
C616	RCE0JKA470BG	6.3V 47U	1	F2A0J470A014
C617	RCE1HKA3R3BG	50V 3.3U	1	F2A1H3R3A015
C618	ECUV1H180JCN	50V 18P	1	
C619	ECUV1H104ZFN	50V 0.1U	1	
C620	ECUV1H180JCN	50V 18P	1	
C621,22	ECUV1H104ZFN	50V 0.1U	2	
C623	RCE0JRS102BJ	6.3V 1000U	1	
C624	ECA1CAK100XB	16V 10U	1	
C625	ECUV1H102KBN	50V 1000P	1	
C626,27	ECUV1H104ZFN	50V 0.1U	2	
C628	ECUV1H101JCN	50V 100P	1	
C629	RCE0JKA470BG	6.3V 47U	1	F2A0J470A014
C649	ECUV1H104ZFN	50V 0.1U	1	
CN201	RJT100W04	CONNECTOR (4P)	1	
CN251	RJT100W11	CONNECTOR (11P)	1	
CN253	RJT100W11	CONNECTOR (11P)	1	
CN301	RJS1A6823	CONNECTOR (23P)	1	K1MN23A00009
CN302	RJS1A6819	CONNECTOR (19P)	1	K1MN19A00013
CN601	RJS1A6223-1	CONNECTOR (23P)	1	K1MN23C00001
CN602	RJS1A6219-1	CONNECTOR (19P)	1	K1MN19C00001
CN603	RJT066H05A	CONNECTOR (5P)	1	K1KA05B00073
CP201	RJU100W04	CONNECTOR (4P)	1	
CP251	RJU100W11	CONNECTOR (11P)	1	
CP603	RJU066H05	CONNECTOR (5P)	1	K1KB05C00003
D251	MA4082LTA	DIODE	1	MAZ40820LF Δ
D301,02	MA165	DIODE	2	MA2C165
D303	RL1N4003N02	DIODE	1	
D304	MA4062H	DIODE	1	MAZ40620H Δ
D307,08	MA4091M	DIODE	2	MAZ40910M Δ
D309-12	MA719TA	DIODE	4	MA2C71900A
D315	MA4056H	DIODE	1	MAZ40560H Δ
D320	MA29WA	DIODE	1	MA2C029WA
D321	MA165	DIODE	1	MA2C165
D401-04	MA165	DIODE	4	MA2C165
D405	MA4051M	DIODE	1	MAZ40510M
D601	LNJ201LPQJA	LED	1	
D609	MA111TX	DIODE	1	MA2J11100L
D610	MA8051M	DIODE	1	MAZ80510M
D611	MA111TX	DIODE	1	MA2J11100L
D612,13	1SS380TE-17	DIODE	2	
D614	MA111TX	DIODE	1	MA2J11100L
D615	MA8062M	DIODE	1	MAZ80620M

Ref. No.	Part No.	Part Name & Description	Pcs	Remarks
FL601	RSL0309-F	FL DISPLAY	1	
IC402	C1BB00000528	IC	1	
IC403	M5218AFPE3	IC	1	COABB000163
IC404	BU4052BCF-E2	IC	1	COJBAR000002
IC405	M5218AFPE3	IC	1	COABB000163
IC406	BU4052BCF-E2	IC	1	COJBAR000002
IC601	C2BBGF000267	IC	1	
IC602	BR93LC46FERR	IC	1	
JK201	SJF3069-8N	EXT IN	1	
JK301	RJT065K20	SYSTEM CONNECTOR (20P)	1	K1FA220B0006
JK302	RJT065K19	SYSTEM CONNECTOR (19P)	1	K1FA219B0001
L301,02	RLQA100JT-Y	COIL	2	G0C100JA0023
L609	RLBN300AV-W	COIL	1	J0JHC0000027
PCB1	REP3123B-M	MAIN P.C.B.	1	[RTL]
PCB2	REP3124B-S	CONTROL P.C.B.	1	[RTL]
Q251	2SC3311ATA	TRANSISTOR	1	2SC3311A0A
Q252	2SC3940AQSTA	TRANSISTOR	1	2SC3940ARA △
Q301	DTC143XSTP	TRANSISTOR	1	B1GACFGH0002
Q302,03	2SC3311ATA	TRANSISTOR	2	2SC3311A0A
Q304	2SB621A-R	TRANSISTOR	1	2SB0621AH
Q305	DTC114ESTP	TRANSISTOR	1	B1GACFJJ0007
Q306	2SD2374PQAU	TRANSISTOR	1	2SD23740J1AU △
Q307	2SD2137PQTA	TRANSISTOR	1	2SD21370PA △
Q308	2SB1417PQTA	TRANSISTOR	1	2SB14170JA △
Q311	2SA1309ATA	TRANSISTOR	1	2SA1309AWA
Q312	DTC114ESTP	TRANSISTOR	1	B1GACFJJ0007
Q313	2SC3940AQSTA	TRANSISTOR	1	2SC3940ARA △
Q404	DTA114ESTP	TRANSISTOR	1	
Q405-08	2SC3327A	TRANSISTOR	4	
Q409	DTA114ESTP	TRANSISTOR	1	B1GCCFJA0002
Q601	UN5214TX	TRANSISTOR	1	UNR521400L
Q602	2SD1819ATX	TRANSISTOR	1	2SD1819A0L
R207,08	ERDS2FJ103	1/4W 10K	2	
R209,10	ERDS2FJ472	1/4W 4.7K	2	
R212	ERDS2FJ100	1/4W 10	1	
R254	ERDS2FJ103	1/4W 10K	1	
R258	ERDS2FJ102	1/4W 1K	1	
R259	ERDS2FJ221	1/4W 220	1	
R260	ERDS2FJ102	1/4W 1K	1	
R261,62	ERDS2FJ103	1/4W 10K	2	
R301-03	ERDS2FJ103	1/4W 10K	3	
R304	ERDS2FJ331	1/4W 330	1	
R305	ERDS2FJ103	1/4W 10K	1	
R306	ERDS2FJ223	1/4W 22K	1	
R307	ERDS2FJ103	1/4W 10K	1	
R308,09	ERDS2FJ472	1/4W 4.7K	2	
R310	ERDS2FJ473	1/4W 47K	1	
R311	ERDS2FJ102	1/4W 1K	1	
R312	ERDS2FJ331	1/4W 330	1	
R313	ERDS2FJ102	1/4W 1K	1	
R314	ERDS2FJ681	1/4W 680	1	
R317,18	ERDS2FJ102	1/4W 1K	2	
R319,20	ERD2FCJ4R7	4.7	2	△
R321,22	ERDS2FJ101	1/4W 100	2	
R323	ERDS2FJ103	1/4W 10K	1	
R324	ERDS2FJ104	1/4W 100K	1	
R325,26	ERDS2FJ102	1/4W 1K	2	
R411	ERDS2FJ101	1/4W 100	1	
R415,16	ERDS2FJ472	1/4W 4.7K	2	
R417,18	ERDS2FJ101	1/4W 100	2	

Ref. No.	Part No.	Part Name & Description	Pcs	Remarks
R421,22	ERDS2FJ101	1/4W 100	2	
R423	ERDS2FJ103	1/4W 10K	1	
R424	ERDS2FJ102	1/4W 1K	1	
R425-27	ERDS2FJ101	1/4W 100	3	
R429,30	ERDS2FJ104	1/4W 100K	2	
R431,32	ERDS2FJ101	1/4W 100	2	
R433,34	ERDS2FJ103	1/4W 10K	2	
R435,36	ERDS2FJ473	1/4W 47K	2	
R437,38	ERDS2FJ682	1/4W 6.8K	2	
R441,42	ERDS2FJ153	1/4W 15K	2	
R443,44	ERDS2FJ682	1/4W 6.8K	2	
R445,46	ERDS2FJ392	1/4W 3.9K	2	
R449,50	ERDS2FJ101	1/4W 100	2	
R452	ERDS2FJ103	1/4W 10K	1	
R455,56	ERDS2FJ101	1/4W 100	2	
R457,58	ERDS2FJ103	1/4W 10K	2	
R459,60	ERDS2FJ153	1/4W 15K	2	
R461,62	ERDS2FJ104	1/4W 100K	2	
R463-65	ERDS2FJ101	1/4W 100	3	
R467,68	ERDS2FJ101	1/4W 100	2	
R469,70	ERDS2FJ223	1/4W 22K	2	
R471,72	ERDS2FJ101	1/4W 100	2	
R473,74	ERDS2FJ103	1/4W 10K	2	
R475,76	ERDS2T0T	1/4W 0	2	
R477-80	ERDS2FJ103	1/4W 10K	4	
R481,82	ERDS2FJ102	1/4W 1K	2	
R483,84	ERDS2FJ332	1/4W 3.3K	2	
R485,86	ERDS2FJ222	1/4W 2.2K	2	
R487,88	ERDS2FJ472	1/4W 4.7K	2	
R489,90	ERDS2FJ392	1/4W 3.9K	2	
R493,94	ERDS2FJ104	1/4W 100K	2	
R495	ERDS2FJ105	1/4W 1M	1	
R497	ERDS2FJ105	1/4W 1M	1	
R501,02	ERDS2T0T	1/4W 0	2	
R503,04	ERDS2FJ102	1/4W 1K	2	
R505,06	ERDS2FJ105	1/4W 1M	2	
R507,08	ERDS2FJ102	1/4W 1K	2	
R601	ERJ6GEYJ221V	1/10W 220	1	
R602	ERJ6GEYJ821V	1/10W 820	1	
R603	ERJ6GEYJ102V	1/10W 1K	1	
R604	ERJ6GEYJ122V	1/10W 1.2K	1	
R605	ERJ6GEYJ152V	1/10W 1.5K	1	
R606	ERJ6GEYJ182V	1/10W 1.8K	1	
R607	ERJ6GEYJ222V	1/10W 2.2K	1	
R608	ERJ6GEYJ332V	1/10W 3.3K	1	
R609-14	ERJ6GEYJ331V	1/10W 330	6	
R616,17	ERJ6GEYJ331V	1/10W 330	2	
R618-20	ERJ6GEYJ103V	1/10W 10K	3	
R621	ERJ6GEYJ332V	1/10W 3.3K	1	
R622-24	ERJ6GEYJ103V	1/10W 10K	3	
R625	ERJ6GEYJ101V	1/10W 100	1	
R626-32	ERJ6GEYJ331V	1/10W 330	7	
R633	ERJ6GEYJ121V	1/10W 120	1	DOG121JA003
R634-39	ERJ6GEYJ331V	1/10W 330	6	
R640	ERJ6GEYJ102V	1/10W 1K	1	
R641	ERJ6GEYJ103V	1/10W 10K	1	
R642,43	ERJ6GEYJ331V	1/10W 330	2	
R644	ERJ6GEYJ101V	1/10W 100	1	
R645	ERJ6GEYJ102V	1/10W 1K	1	
R646	ERJ6GEYJ103V	1/10W 10K	1	
R647	ERJ6GEYJ104V	1/10W 100K	1	
R648	ERJ6GEYJ102V	1/10W 1K	1	
R649	ERJ6GEYJ000V	1/10W 0	1	
R650	ERJ6GEYJ103V	1/10W 10K	1	
R651	ERJ6GEYJ102V	1/10W 1K	1	
R652	ERJ6GEYJ331V	1/10W 330	1	
R653	ERJ6GEYJ223V	1/10W 22K	1	
R654	ERJ6GEYJ331V	1/10W 330	1	
R655	ERJ6GEYJ223V	1/10W 22K	1	
R656	ERJ6GEYJ331V	1/10W 330	1	
R657	ERJ6GEYJ105	1/10W 1M	1	ERJ6GEYJ105V
R658	ERJ6GEYJ102V	1/10W 1K	1	
R659	ERJ6GEYJ331V	1/10W 330	1	

Ref. No.	Part No.	Part Name & Description	Pcs	Remarks
R660	ERJ6GEYJ101V	1/10W 100	1	
R661-63	ERJ6GEYJ331V	1/10W 330	3	
R664	ERJ6GEYJ472V	1/10W 4.7K	1	
R665	ERJ6GEYJ101V	1/10W 100	1	
R666,67	ERJ6GEYJ331V	1/10W 330	2	
R668	ERJ6GEYJ223V	1/10W 22K	1	
R669	ERJ6GEYJ101V	1/10W 100	1	
R670,71	ERJ6GEYJ151V	1/10W 150	2	
R672	ERJ6GEYJ103V	1/10W 10K	1	
R674	ERJ6GEYJ103V	1/10W 10K	1	
R675	ERJ6GEYJ101V	1/10W 100	1	
R676	ERJ6GEYJ223V	1/10W 22K	1	
R677-80	ERJ6GEYJ103V	1/10W 10K	4	
R681	ERJ6GEYJ106V	1/10W 10M	1	
R682,83	ERJ6GEYJ473V	1/10W 47K	2	
RJ721-24	ERJ8GEY0R00V	CHIP JUMPER	4	
S601-08	EVQ11G05R	SW,OPERATION	8	
X601	RSXD32K7S05	OSCILLATOR	1	H0A327200029
X602	H2B419400005	OSCILLATOR	1	
Z601	RCDGP1U26XD	REMOTE SENSOR	1	B3RAD0000010

15 Cabinet Parts Location

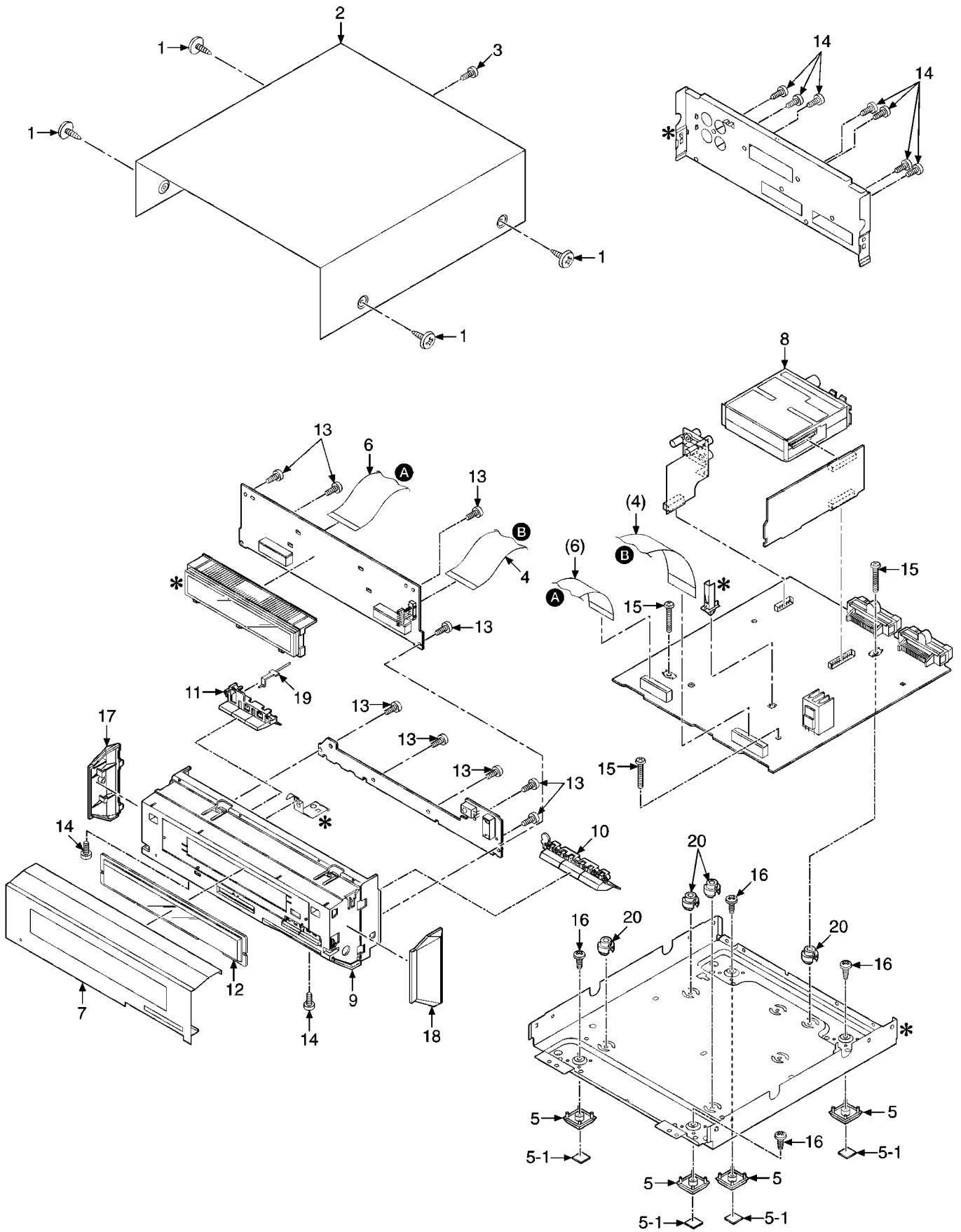

Note : We do not supply those items of parts marked * .