

# Service Manual

Tuner

Tuner

System: SC-HD50

## ST-HD50

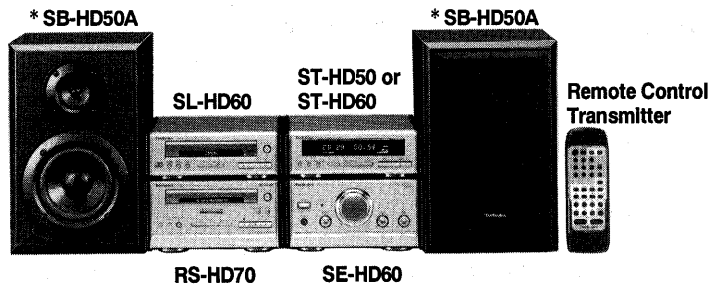

Colour

(N) ..... Gold

Area

(E) ..... Europe.

\* System Areas Tuner  
 SC-HD50 (Germany, Italy.) : ST-HD60  
 SC-HD50 (Europe, Russia.) : ST-HD50

Because of unique interconnecting cables, when a compact requires service, send or bring in the entire system.

## Specifications

### Pre-amplifier Section

Input sensitivity/impedance

EXTERNAL: 250 mV/15 kohm

Output level

EXTERNAL: 250 mV/1.5 kohm

Frequency response

EXTERNAL: 50 Hz – 25 kHz

S/N

EXTERNAL: DIN 82 dB (83 dB, IHF)

### FM tuner Section

Frequency range: 87.50 – 108.00 MHz (0.05 MHz steps)

Sensitivity: 1.8  $\mu$ V (IHF usable)S/N 26 dB: 1.5  $\mu$ V

S/N

MONO: 70dB (75 dB, IHF)

Stereo separation

1 kHz: 35 dB

Antenna terminal(s): 75 ohm (unbalanced)

### AM tuner Section

Frequency range: 522 – 1611 kHz (9 kHz steps)

530 – 1620 kHz (10 kHz steps)

Sensitivity (S/N 20 dB): 500  $\mu$ V/m

MAIN: 80 dB

### Timer Section

Clock: Quartz-lock type

Function: 24-hour programmable;

Play timer (1 time), Rec timer (1 time)

Sleep (120 min., 30 min., intervals)

Setting: 1 minute – 23 hours 59 minutes (1 min. intervals)

### General

Dimensions: 196(W)/67(H)/235(D) mm

Weight: 1.2 kg

### Notes:

Specifications are subject to change without notice.

Weight and dimensions are approximate.

### System/SC-HD50:

Tuner: ST-HD50 or ST-HD60, Compact Disc Player: SL-HD60, Amplifier: SE-HD50, Cassette Deck: RS-HD70, Speakers: SB-HD50A

Notes: \* ..... Made in PAES

### ⚠ WARNING

This service information is designed for experienced repair technicians only and is not designed for use by the general public. It does not contain warnings or cautions to advise non-technical individuals of potential dangers in attempting to service a product.

Products powered by electricity should be serviced or repaired only by experienced professional technicians. Any attempt to service or repair the product or products dealt with in this service information by anyone else could result in serious injury or death.

# Technics®

© 1997 Matsushita Electric Industrial Co., Ltd.  
 All rights reserved. Unauthorized copying  
 and distribution is a violation of law.

## Contents

	Page		Page
Location of Controls .....	2	Printed Circuit Board Diagram .....	15 ~ 17
Setting the Time .....	2	Wiring Connection Diagram .....	18
About the Self-Diagnostic Mode .....	3	Terminal Function of IC's .....	19
Operation Checks and Main Component Replacement Procedures .....	4,5	Block Diagram .....	20 ~ 22
Type Illustration of ICs, Transistors and Diodes .....	5	Replacement Parts List (Electrical) .....	23, 24
To Supply Power Source .....	6	Resistors and Capacitors .....	25, 26
Schematic Diagram .....	7 ~ 14	Replacement Parts List (Cabinet, Packing) .....	27
		Cabinet Parts Location .....	28

### NOTE:

Refer to the service manual for Model No. SE-HD50 (ORDER No. AD9702022C3) for information on "Accessories", "Installation", "Connections" and "Packaging".

## Location of Controls

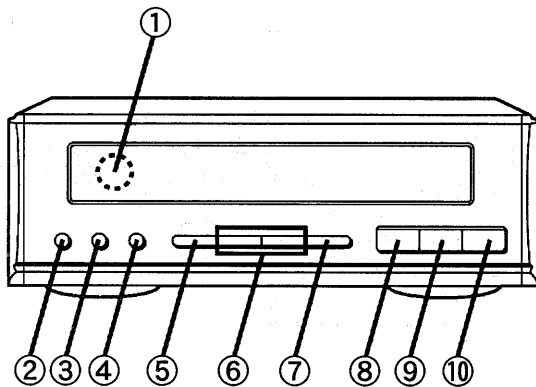

- ① Remote control signal sensor (SENSOR)
- ② Record timer button (⏸ REC)
- ③ Play timer button (⏪ PLAY)
- ④ Clock/timer buttons (CLOCK/TIMER)
- ⑤ Set button (SET)
- ⑥ Tuning/time adjust button (V, ^, TUNING/TIME ADJUST)
- ⑦ Tuning mode select button (TUNING MODE)
- ⑧ Source input select button (INPUT SELECTOR)
- ⑨ RDS display mode select button (RDS DISPLAY MODE)
- ⑩ Band select button (FM/AM)

## Setting the Time

The tuner display the time, frequency and other information on CDs and tapes.

This is a 24-hour display clock.

These instructions explain how to set the timer for 16:25 on Wednesday.

### 1 Switch on the power.

### 2 ① Press CLOCK/TIMER to show "CLOCK".

Every time you press the button, the indication changes in the order of CLOCK → ⏸ REC → ⏪ PLAY → Original display.

Within 8 seconds:

### ② Press SET.

### 3 ① Press V or ^ to select the day.

Every time you press one of the button, the indication changes in the order of SUN ⇄ MON ⇄ TUE ⇄ WED ⇄ THU ⇄ FRI ⇄ SAT.

### ② Press SET.

### 4 ① Press V or ^ to select the hour.

### ② Press SET.

### 5 ① Press V or ^ to select the minutes.

### ② Press SET to finish setting the time.

The display will return to the previous display after about 3 seconds.

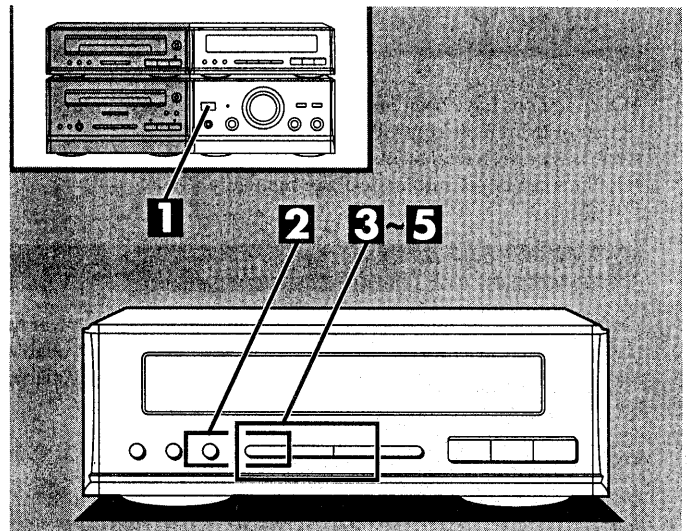

### When " - - : - " appears:

If flashes when you connect the AC power supply cord for the first time or if there has been a power failure. Reset the time as explained above.

### If the minutes setting is off:

1. Press CLOCK/TIMER.
2. Press SET 3 times.
3. Press V or ^ to set the minutes, and then press SET.

### To display the clock again:

Press CLOCK/TIMER.  
The clock display will appear for about 8 seconds.

### For your reference:

When you turn OFF the system from the POWER button, the system goes on standby and the STANDBY indicator lights up.

## ■About the Self-Diagnostic Mode

This unit is equipped with a self-diagnostic function which, in the event of a malfunction, automatically displays a code indicating the nature of the malfunction. Use this self-diagnostic function when servicing the unit.

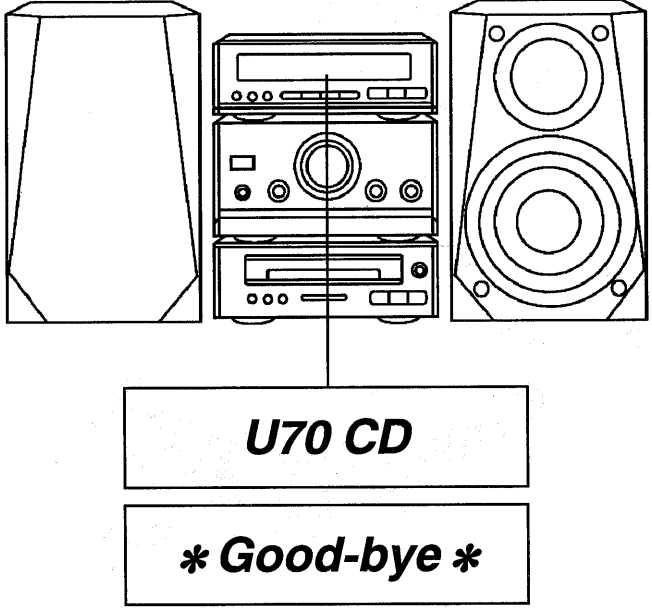
Display method	Display location
<p><b>To display the malfunction code</b></p> <p>U70 CD ..... Automatically displays on the stereo tuner processor when a malfunction occurs.</p> <p>* Good-bye * ..... Automatically displays on the stereo tuner processor when a malfunction occurs.</p> <p><b>To return to the normal display</b></p> <p><b>1. For U70 CD:</b></p> <ul style="list-style-type: none"> <li>● Press an any operation button on the stereo tuner.</li> <li>● To re-display the code, switch the power off (POWER STANDBY button), and then switch power back on again.</li> </ul> <p><b>2. For * Good-bye * :</b></p> <ul style="list-style-type: none"> <li>● If “* Good-bye *” is displayed, the power will automatically be switched off and the standby indicator will light up.</li> <li>● “* Good-bye *” will be displayed for 3 seconds, and then the clock will be displayed.</li> <li>● To re-display the code, switch the power on. “* Good-bye *” will be re-displayed, and then after 3 seconds the clock will be displayed and the power will automatically switch off.</li> </ul>	

### Display contents

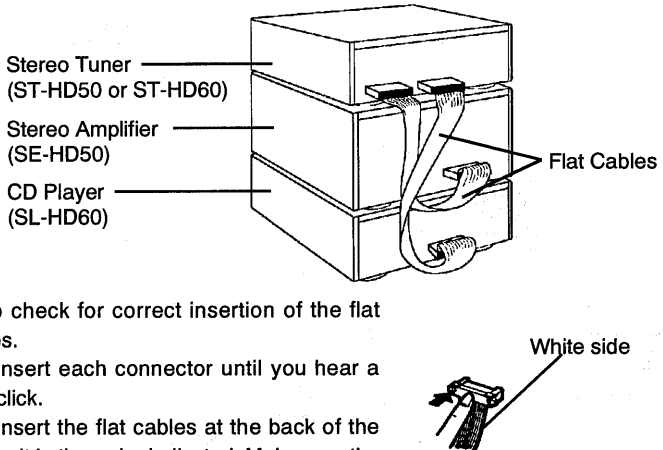
Display code	Problem or condition	Correction procedure
<p><b>U70 CD</b> (displayed automatically)</p>	<p>A bus-line communications error has occurred as a result of the flat cables being inserted incorrectly, thus preventing the system from operating.</p> <p>1.If “U70 CD” is displayed on the stereo tuner, the CD Player cannot be operated by remote control.</p>	 <p>1. To check for correct insertion of the flat cables.</p> <ol style="list-style-type: none"> <li>①Insert each connector until you hear a click.</li> <li>②Insert the flat cables at the back of the unit in the order indicated. Make sure the white side of the cable is on your right side.</li> </ol> <p>2. Breakage of flat cable. (Check and replace as necessary.)</p> <p>3. If the problem is not corrected by items (1.) and (2.) above, this indicates a faulty IC.</p> <p><b>ST-HD50/60:</b> IC901 (M38197MA146F)</p> <p><b>SL-HD60:</b> IC403 (LC66356B4H02)</p> <p>Check these IC's and replace as necessary.</p>
<p>* Good-bye *</p>	<p>When the power switch is switched on, it automatically switches back off, making it impossible to switch power on.</p>	<ul style="list-style-type: none"> <li>● Faulty Stereo Tuner (ST-HD50) output IC (IC501). (When a DC voltage is applied to the speaker terminals.)</li> </ul>

## Operation Checks and Main Component Replacement Procedures

- NOTE**
1. This section describes procedures for checking the operation of the major printed circuit boards and replacing the main components.
  2. For reassembly after operation checks or replacement, reverse the respective procedures. Special reassembly procedures are described only when required.

### 1. Checking for the tuner P.C.B. and FL P.C.B.

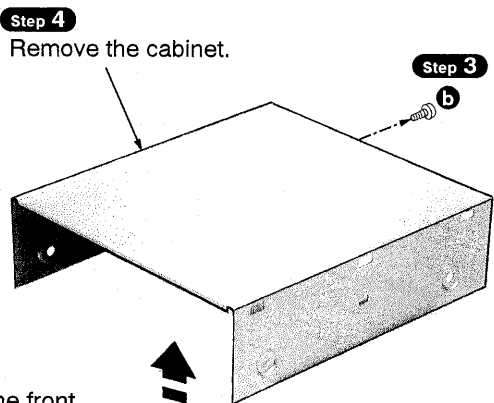
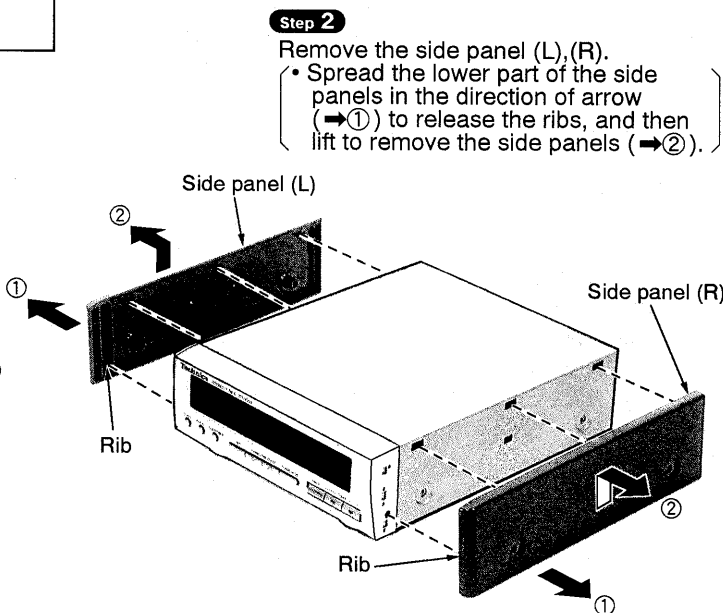
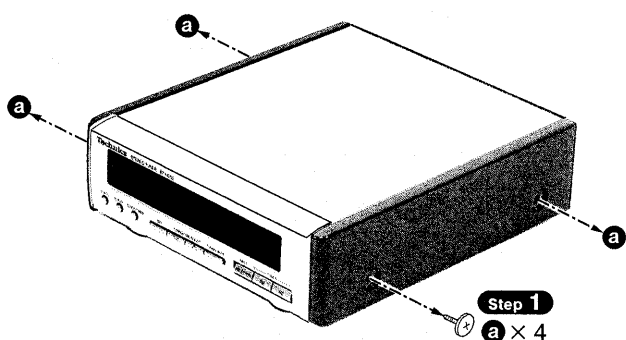

- Check the tuner P.C.B. and FL P.C.B. as shown below.

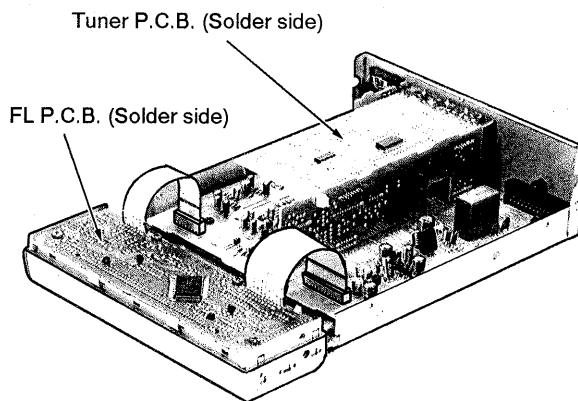
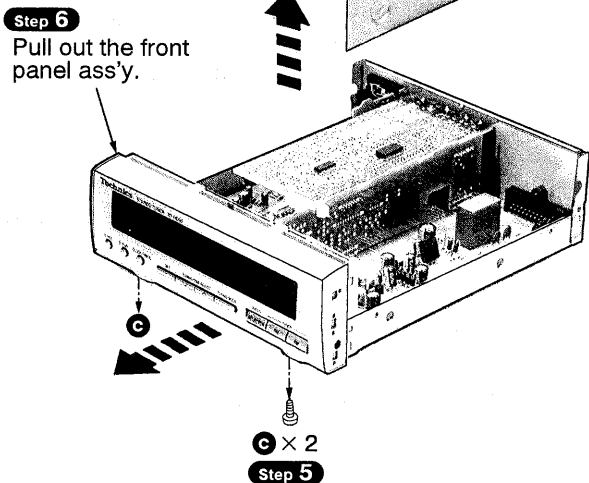

**2. Checking for the main P.C.B.**

• Follow **Step 1** ~ **Step 6** in item 1 on page 4.

• Check the main P.C.B. as shown below.

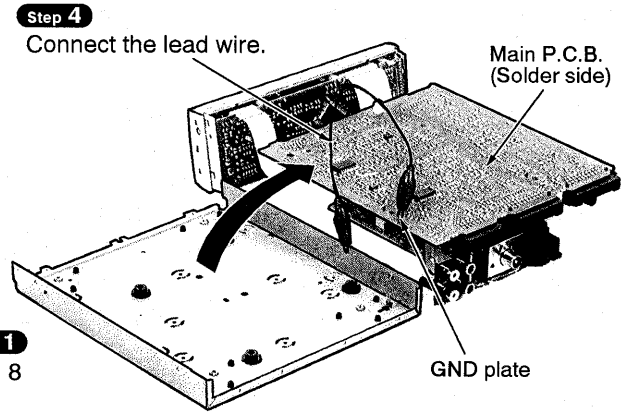
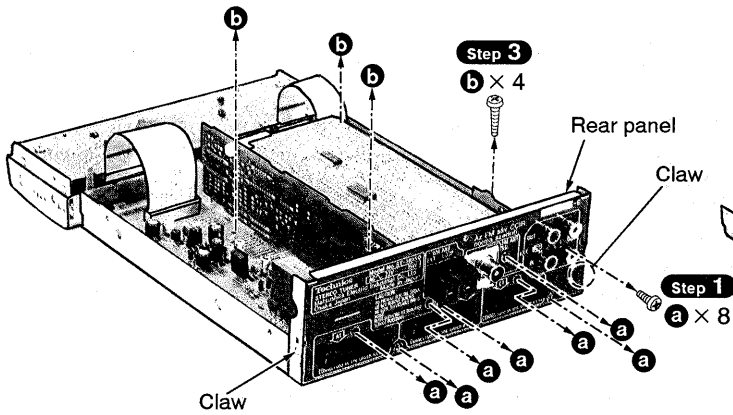

**Step 2**  
Release the 2 claws, and then remove the rear panel.

**■ Type Illustration of ICs, Transistors and Diodes**

<p>No.1</p> <table border="1"> <tr><td>LA1832MH-TEL</td><td>24PIN</td></tr> <tr><td>LC7218M-TE-L</td><td>24PIN</td></tr> <tr><td>NJU7313AMT2</td><td>30PIN</td></tr> <tr><td>M62425FPE1</td><td>36PIN</td></tr> </table>	LA1832MH-TEL	24PIN	LC7218M-TE-L	24PIN	NJU7313AMT2	30PIN	M62425FPE1	36PIN	<p>M5218AFPE3 M5219FPTA</p>	<p>M38197MA146F</p>	<p>2SC3940AQSTA</p>	<p>2SB621AQRSTA</p>
LA1832MH-TEL	24PIN											
LC7218M-TE-L	24PIN											
NJU7313AMT2	30PIN											
M62425FPE1	36PIN											
<p>2SD2144STA DTC143XSTP</p>		<p>2SA1309AQSTA 2SC2785FETA 2SC2787LTA 2SC3311AQSTA 2SC3311ARSTA UN4111AITA UN4115TA UN4214AITA</p>	<p>2SB1417PQTA 2SD2137PQTA</p>	<p>RL1N4003N02</p>								
<p>MA4150MTA MA4300MTA</p>	<p>MA185TA</p>		<p>MA4039MTA MA4051MTA MA4062HTA MA4082LTA</p>	<p>1SS291TA MA165TA</p>								

## ■ To Supply Power Source

This unit ST-HD50 is designed to operate on power supplied from the Amplifier SE-HD50. When operating the unit ST-HD50 alone for testing and servicing, without having power supplied from the Amplifier SE-HD50, use the following method.

### Power Supply to Main Circuit

1. Short the section between the test points **TP602** (CT) and **TP610** (D.GND), and as well as the section between the test points **A. GND** (J601) and **TP610** (D.GND).
2. Connect the 10 V AC power through the capacitor (35V 100 $\mu$ F) to pin 1 of the indicator module FL901 and the GND terminal through the capacitor (35V 100 $\mu$ F) to pin 57 of the same FL901 module.
3. Apply 10 V AC power to the section between the point **TP601** (AC) and the point **TP602** (CT) as well as the section between the point **TP603** (AC) and the point **TP602** (CT). This unit comes to stand-by mode.
4. Short the section between the jumper **TP611** (JK603-pin 9) and the point **TP610** (D.GND) for a moment. The main circuit comes to power ON mode. (Whenever this operation is performed, power, ON/OFF mode is repeated.)

### To Check Signals

Connect the oscilloscope or the speaker with the built-in amplifier to the section between the point J626 [ LINE OUT (R-ch) ] and the point **TP610** (D.GND) as well as the section between the point J627 [ LINE OUT (L-ch) ] and the point **TP610** (D.GND) as shown in Fig. 1, and check if the signals are outputting from this unit.

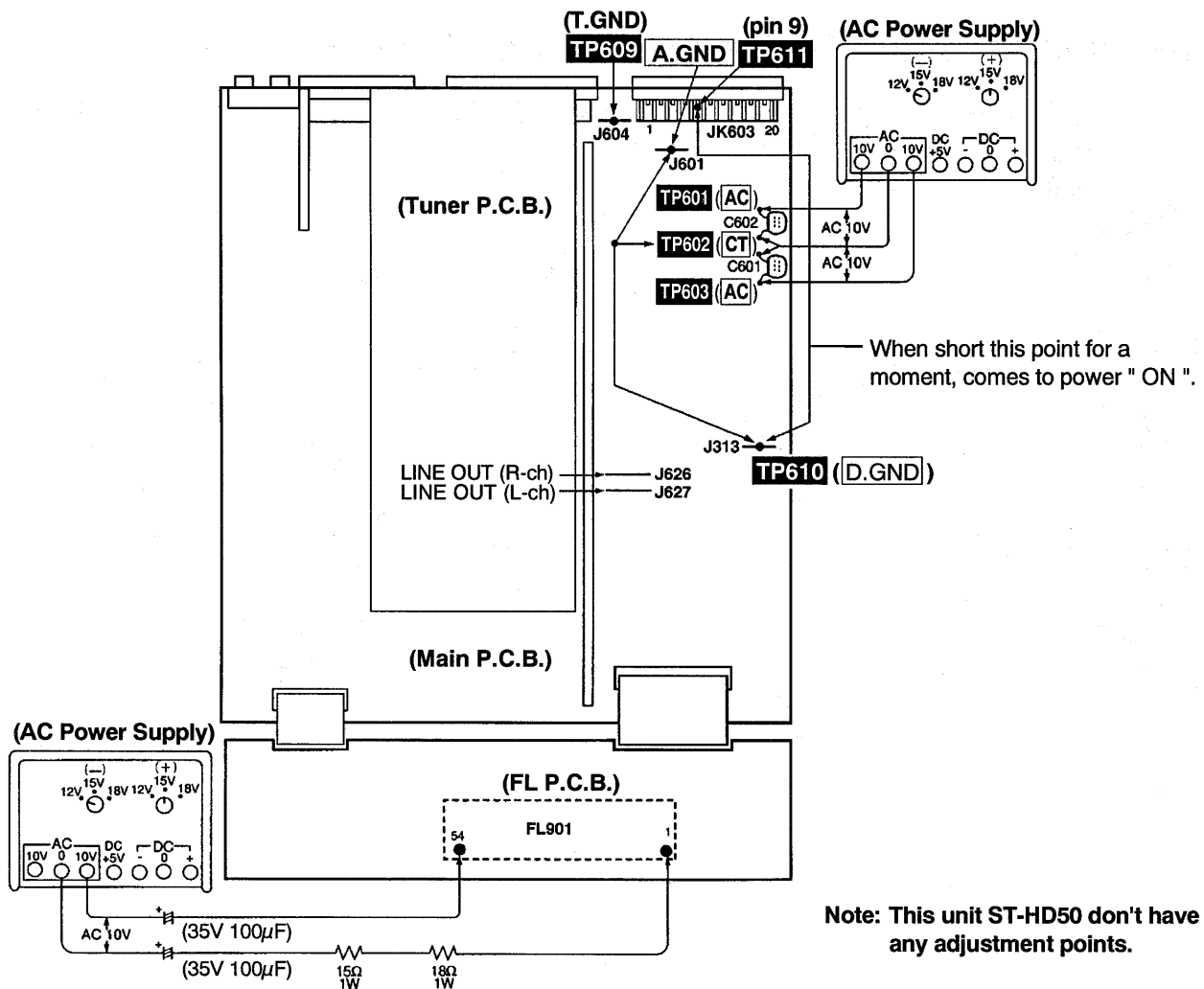

Fig. 1

# Schematic Diagram

	Page
<b>A</b> TUNER CIRCUIT .....	8, 9
<b>B</b> CONNECTOR CIRCUIT .....	10
<b>C</b> INPUT/OUTPUT CIRCUIT .....	10
<b>D</b> MAIN CIRCUIT .....	10 ~ 12
<b>E</b> FL CIRCUIT .....	13, 14
<b>F</b> OPERATION CIRCUIT .....	14

● This schematic diagram may be modified at any time with the development of new technology.

**Notes:**

- **S901** : Record timer switch (⊖ REC)
- **S902** : Play timer switch (⊕ PLAY)
- **S903** : Clock/Timer switch (CLOCK/TIMER)
- **S904** : Set switch (SET)
- **S905,906** : Tuning/Time adjust switch (TUNING/TIME ADJUST)  
(S905: DOWN, S906: UP)
- **S907** : Tuning mode select switch (TUNING)
- **S908** : Source input select switch (INPUT SELECTOR)
- **S909** : FM band select switch (TUNER, FM)
- **S910** : AM band select switch (TUNER, AM)

● Indicated voltage values are the standard values for the unit measured by the DC electronic circuit tester (high-impedance) with the chassis taken as standard. Therefore, there may exist some errors in the voltage values, depending on the internal impedance of the DC circuit tester.

No mark: Power ON

● Voltage values and waveform are measured as indicated in the schematic diagram when test points between **TP602** and **TP610** , and between **TP610** and **A. GND** , and between **TP609** and **A. GND** are shoted.

No mark: FM MODE ( ) : AM MODE

● Important safety notice:

Components identified by  mark have special characteristics important for safety.

Furthermore, special parts which have purposes of fire-retardant (resistors), high-quality sound (capacitors), low-noise (resistors), etc. are used. When replacing any of components, be sure to use only manufacturer's specified parts shown in the parts list.

● **Caution!**

- IC and LSI are sensitive to static electricity.
- Secondary trouble can be prevented by taking care during repair.
- Cover the parts boxes made of plastics with aluminum foil.
- Ground the soldering iron.
- Put a conductive mat on the work table.
- Do not touch the legs of IC or LSI with the fingers directly.

● **Voltage and signal line**

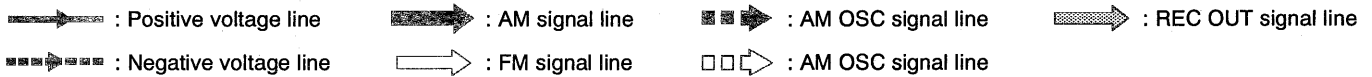

**A** TUNER CIRCUIT (P.C.Board: on page 15)

: Positive voltage line

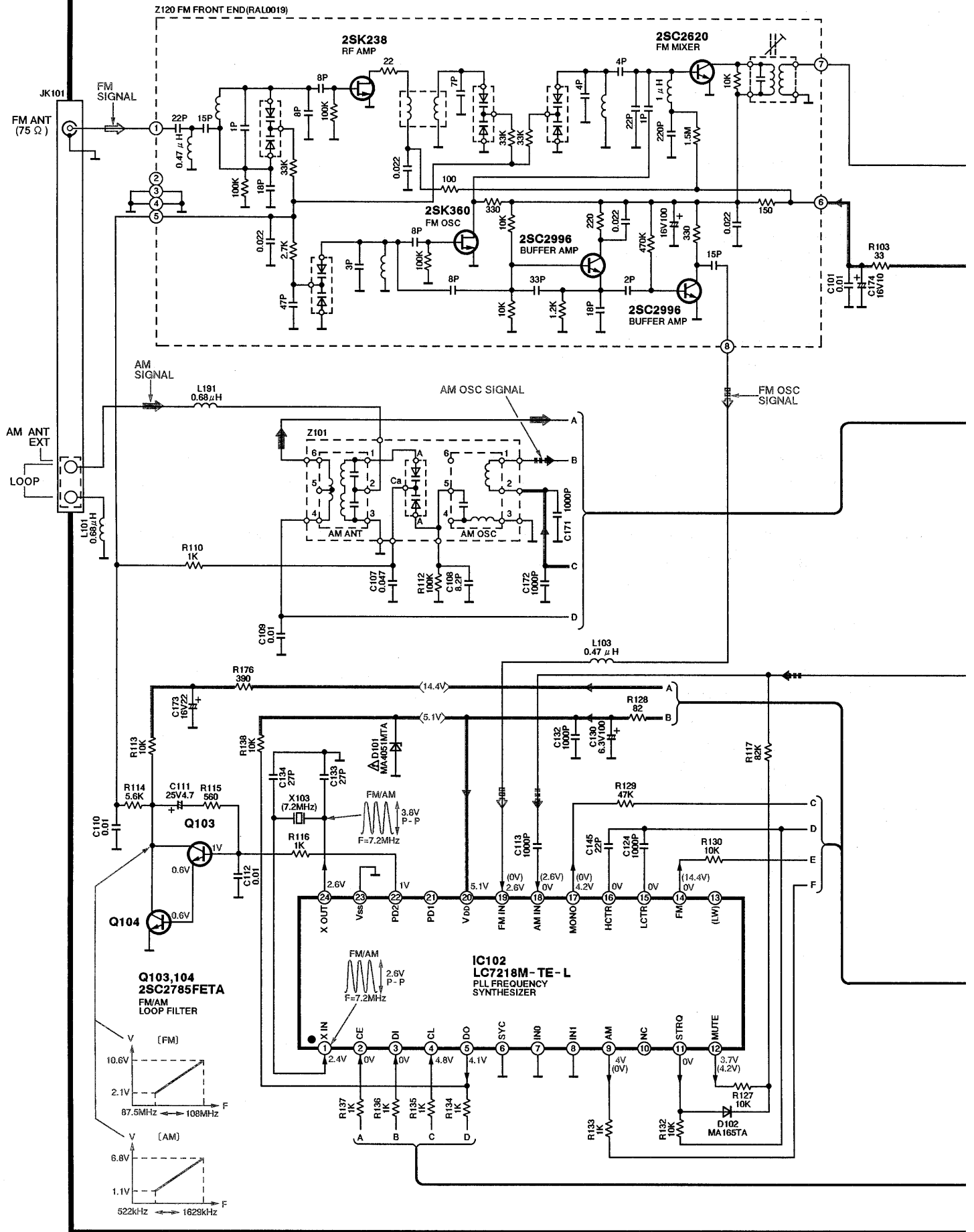



➡ : AM signal line    ➡ : FM signal line    ⏏ : AM OSC signal line    □ : AM OSC signal line

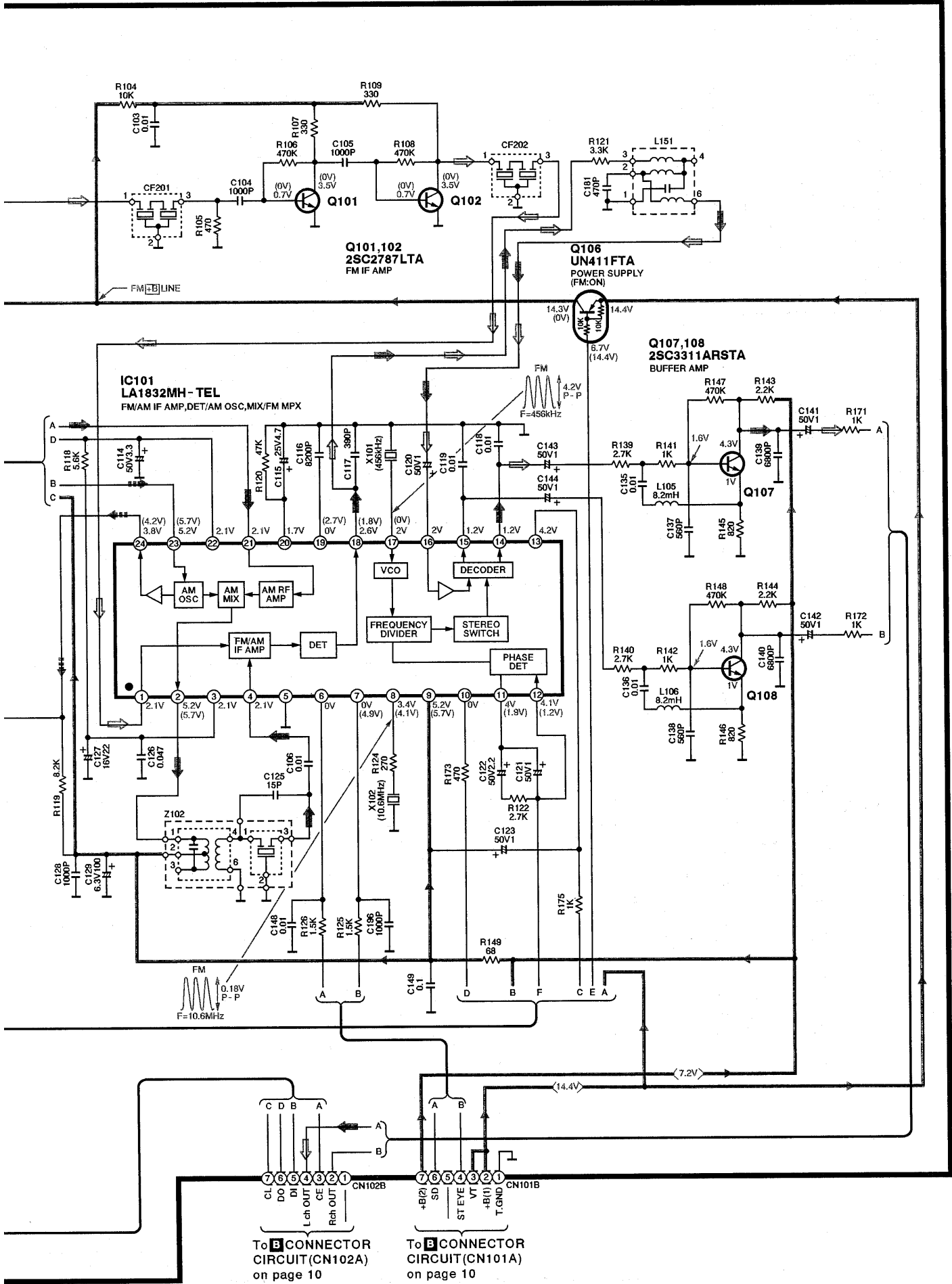

**C INPUT/OUTPUT CIRCUIT**  
(P.C.Board: on page 15)

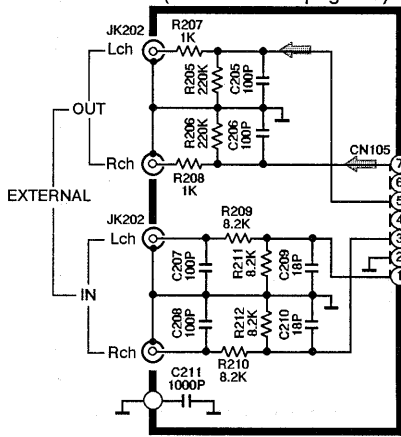

- : Positive voltage line
- : Negative voltage line
- : AM signal line
- : FM signal line
- : REC OUT signal line

**D MAIN CIRCUIT (P.C.Board: on page 16)**

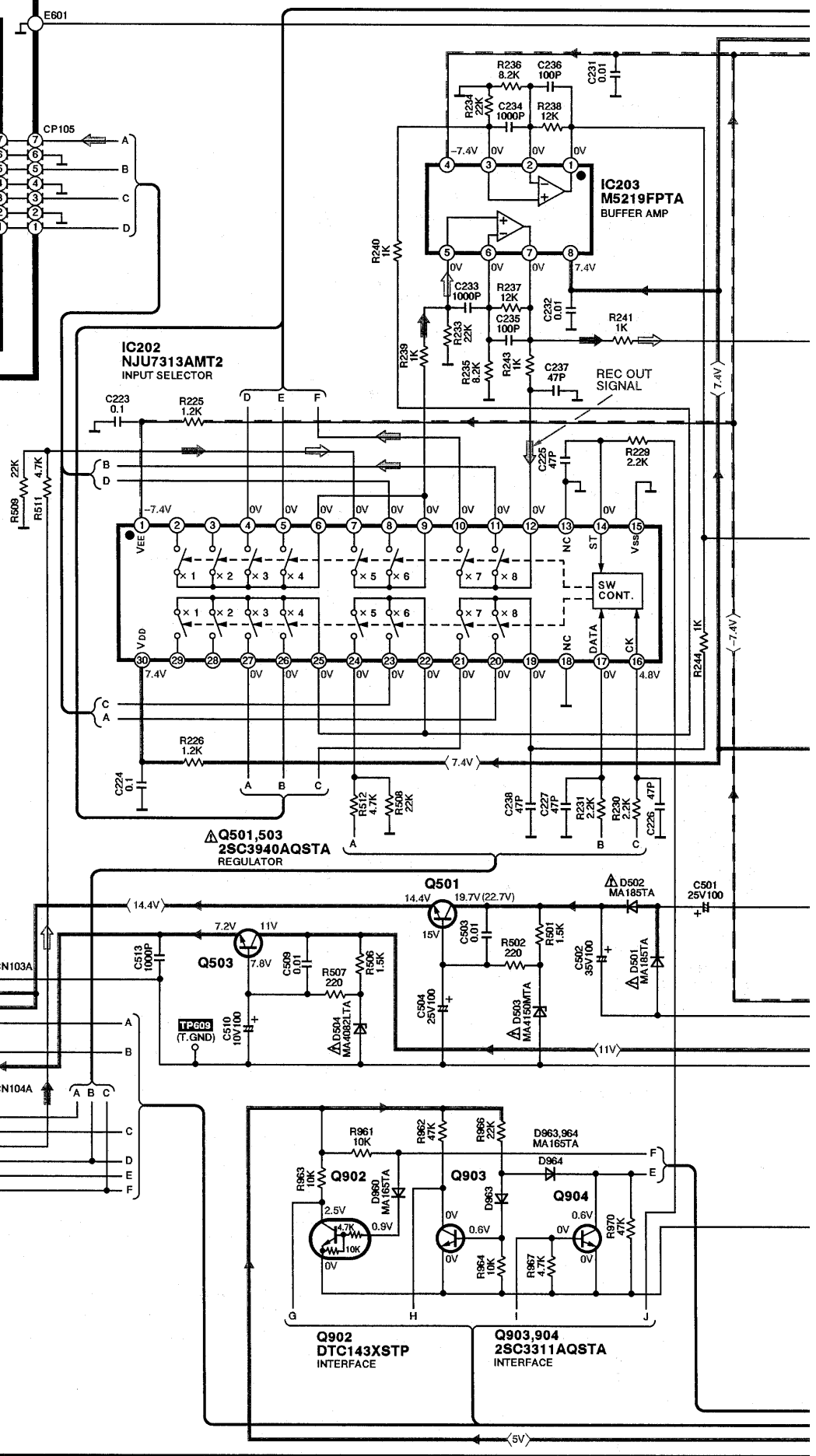

**B CONNECTOR CIRCUIT**  
(P.C.Board: on page 15)

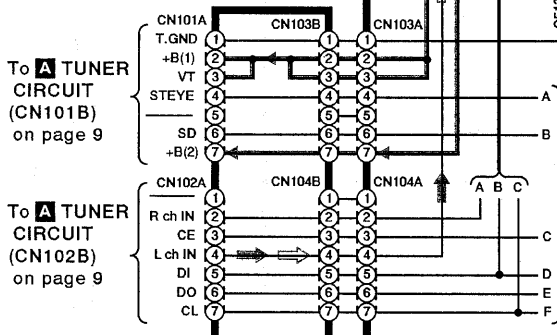

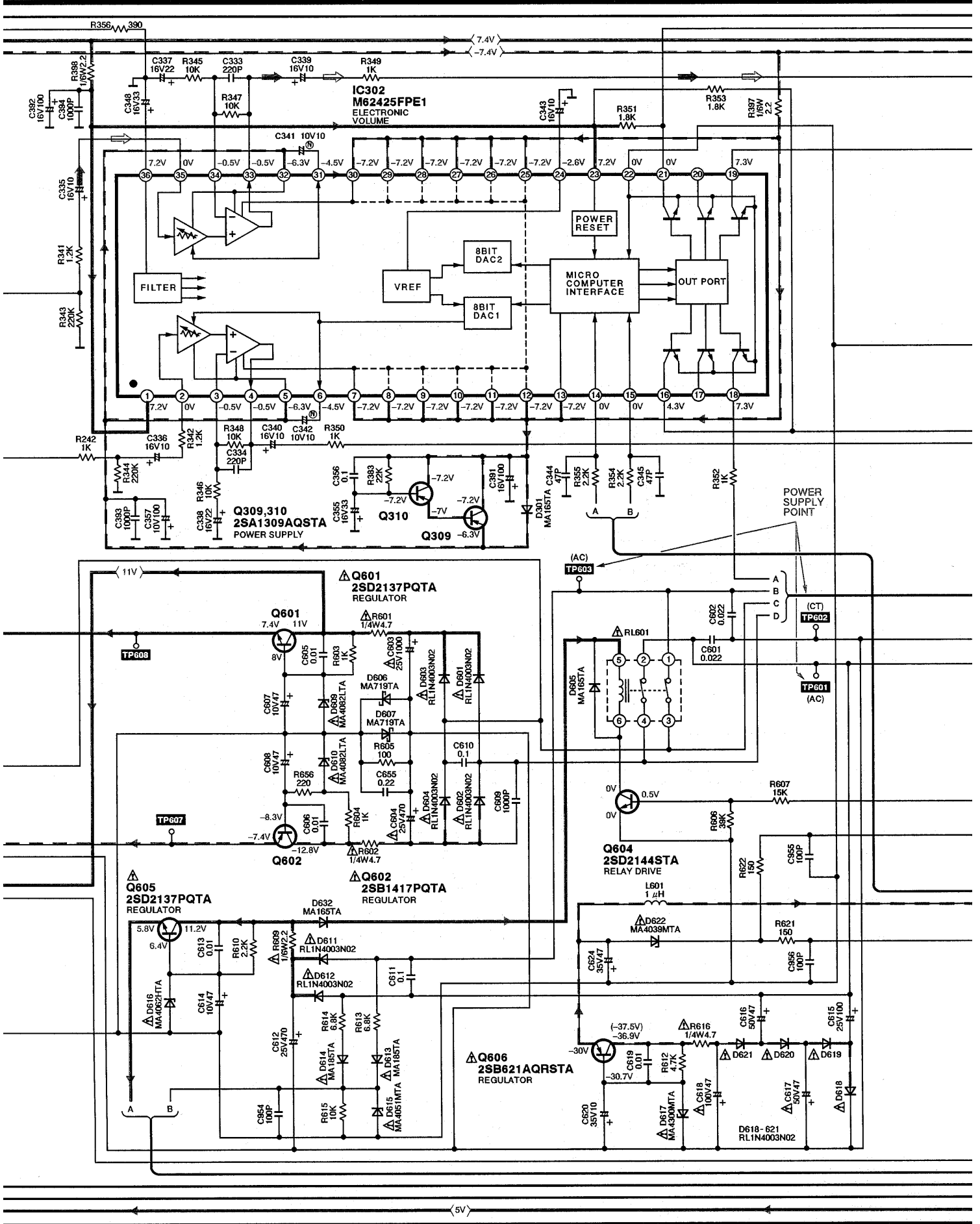

**D** MAIN CIRCUIT (P.C.Board: on page 16)

→ : Positive voltage line

⇄ : Negative voltage line

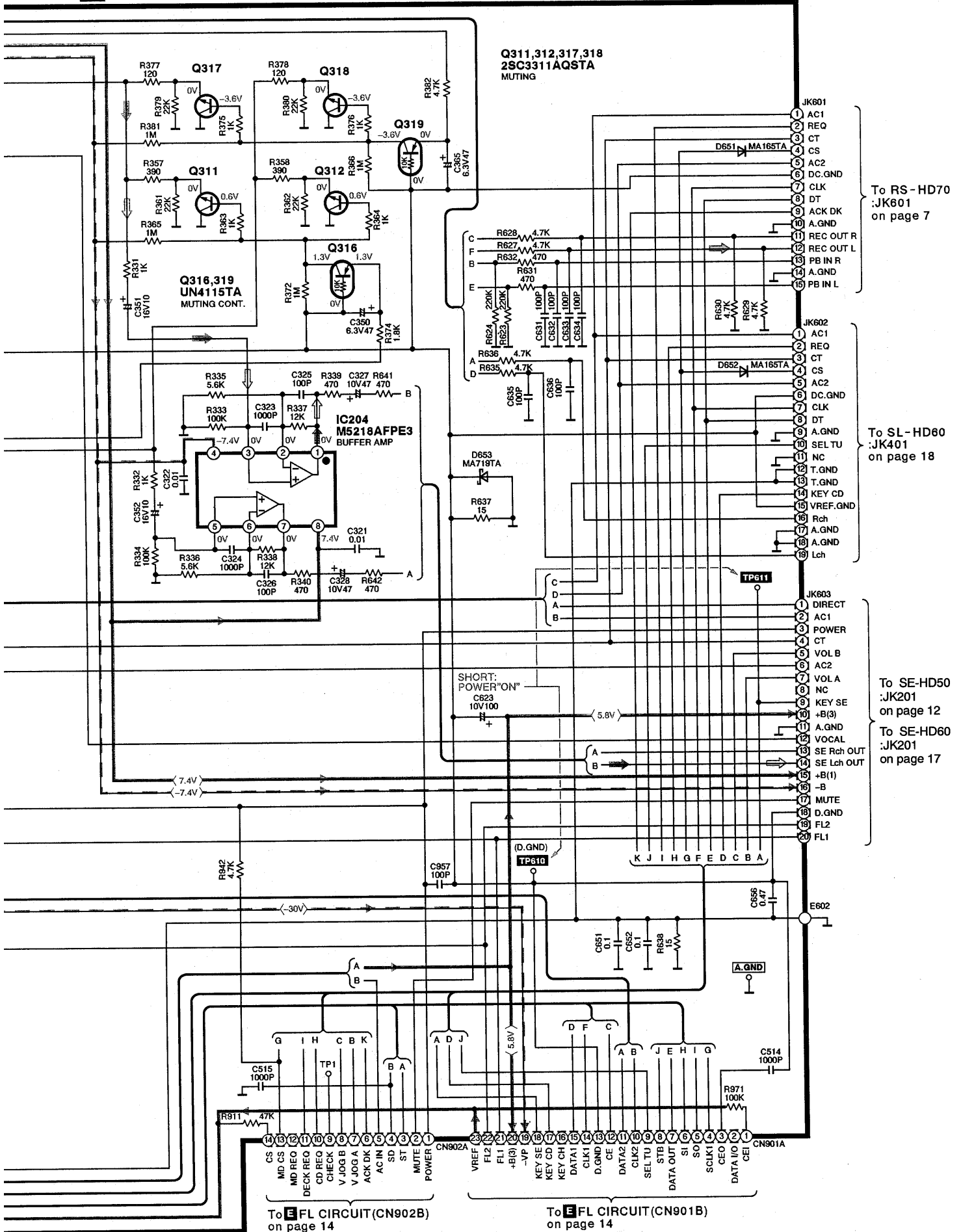

E FL CIRCUIT (P.C.Board:on page 17) : AM signal line : FM signal line : REC OUT signal line

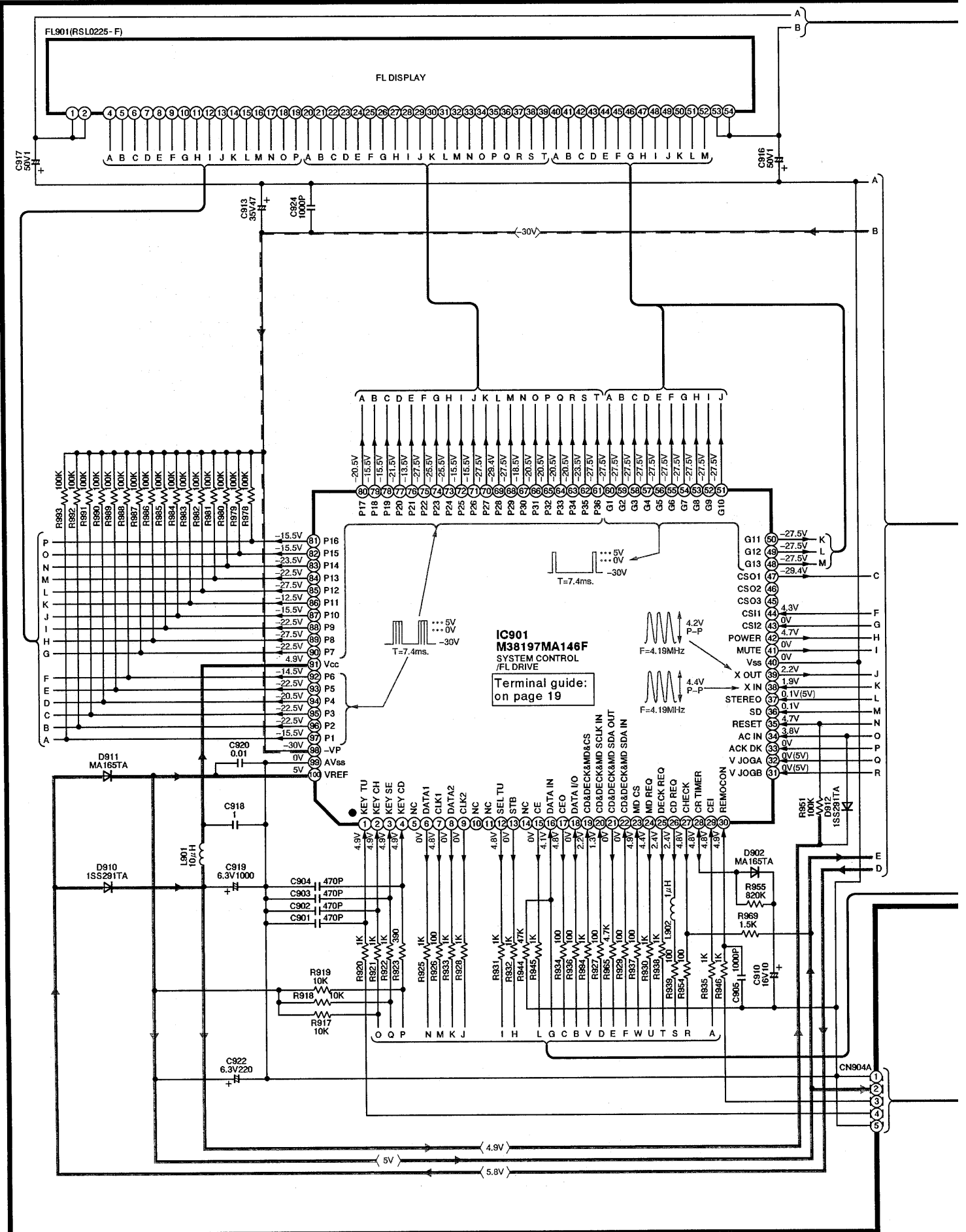

**IC901**  
**M38197MA146F**  
SYSTEM CONTROL  
/FL DRIVE

Terminal guide:  
on page 19

→ : Positive voltage line    - - - - - : Negative voltage line

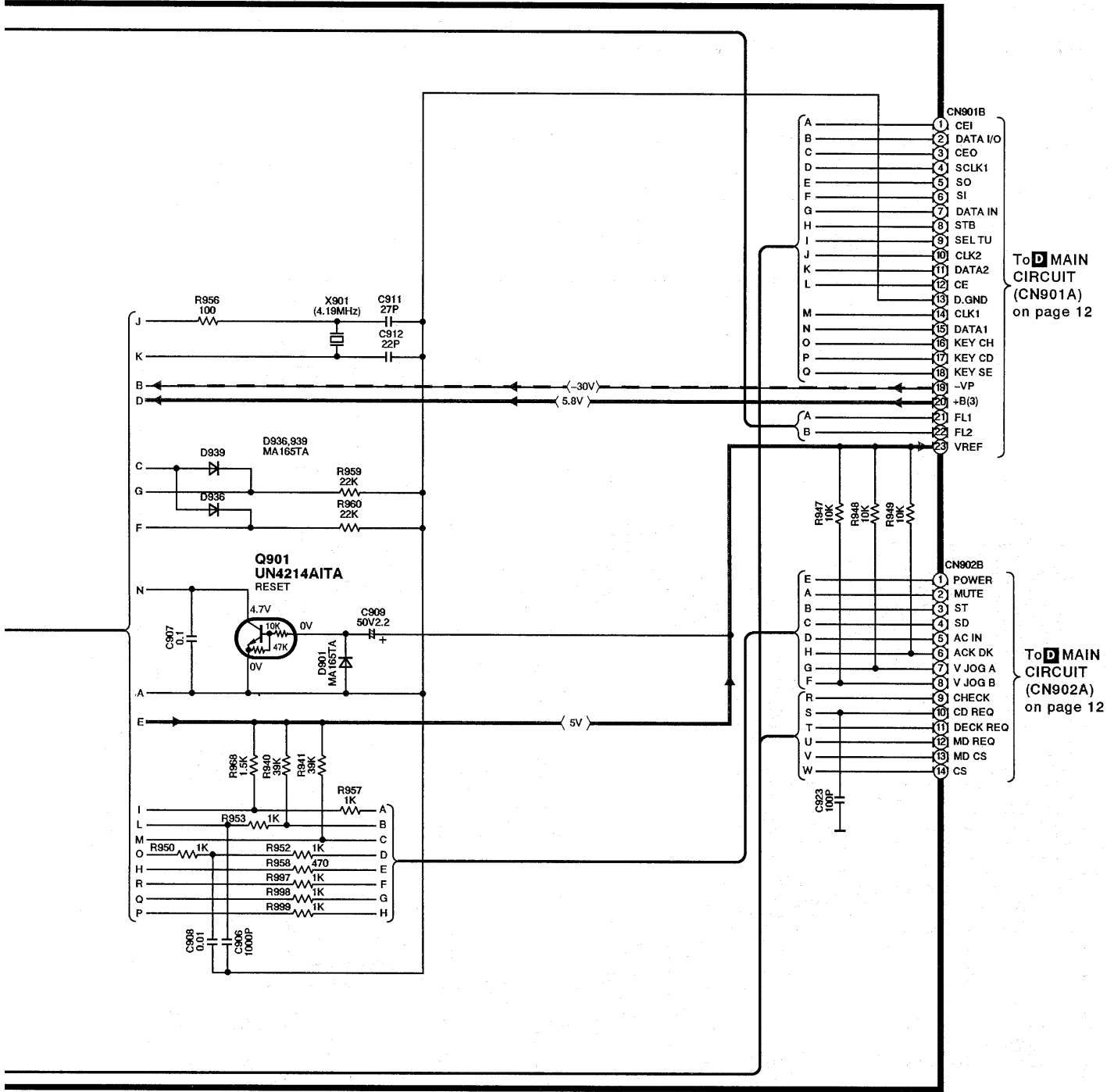

**F OPERATION CIRCUIT (P.C.Board: on page 17)**

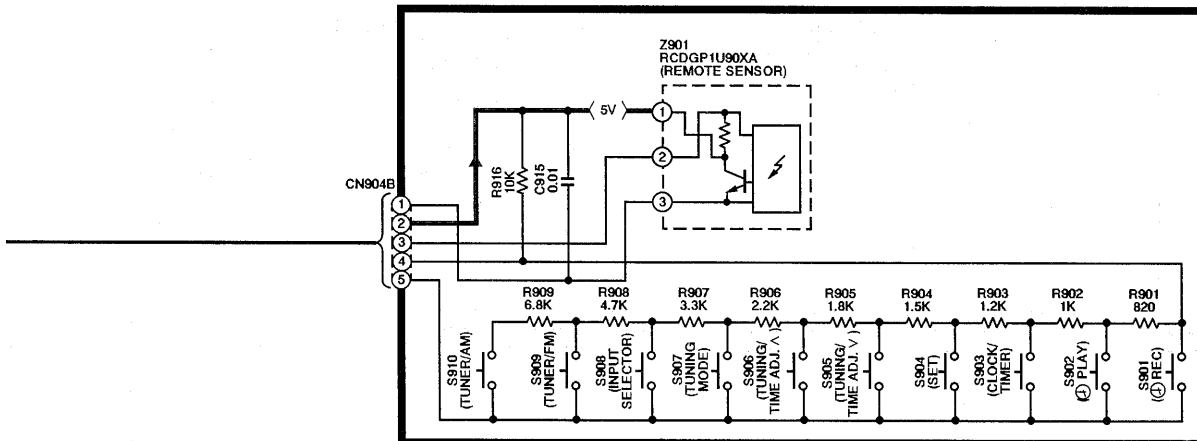

# Printed Circuit Board Diagram

This circuit board diagram may be modified at any time with the development of new technology.

## A TUNER P.C.B.

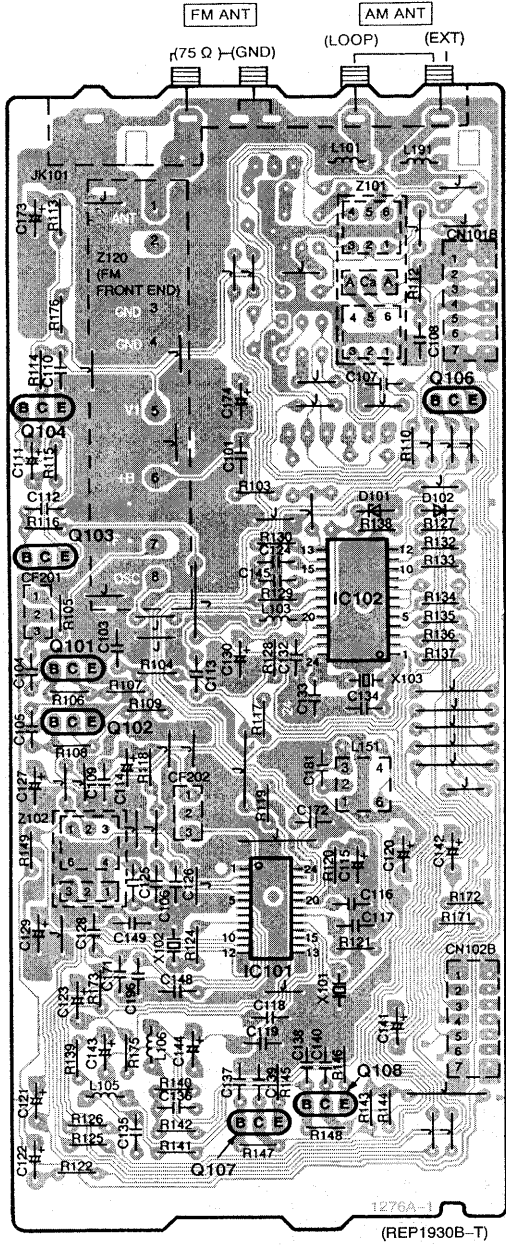

## B CONNECTOR P.C.B.

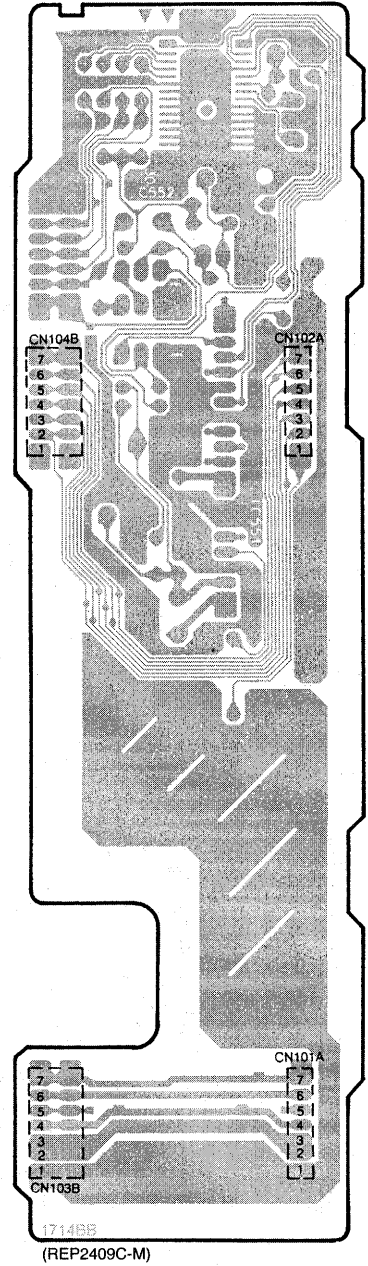

## C INPUT/OUTPUT P.C.B.

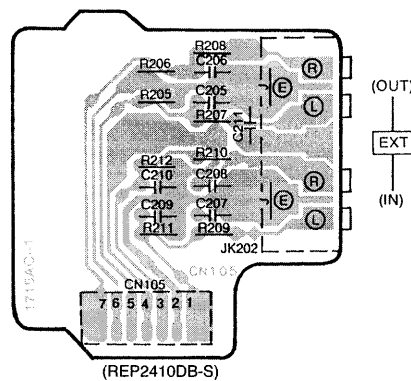

**D** MAIN P.C.B.

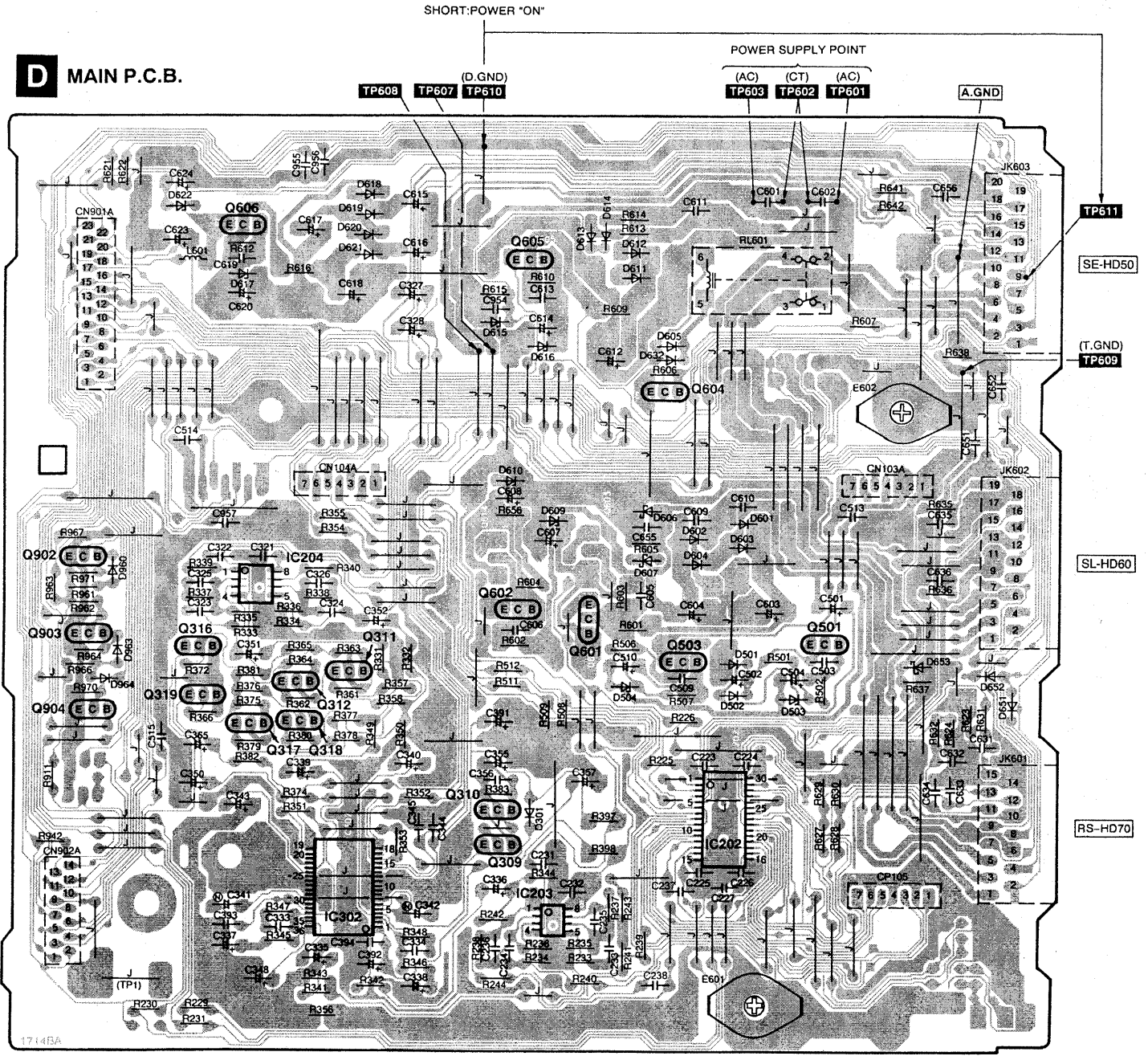

17:46A

(REP2409C-M)



**E** FL P.C.B.

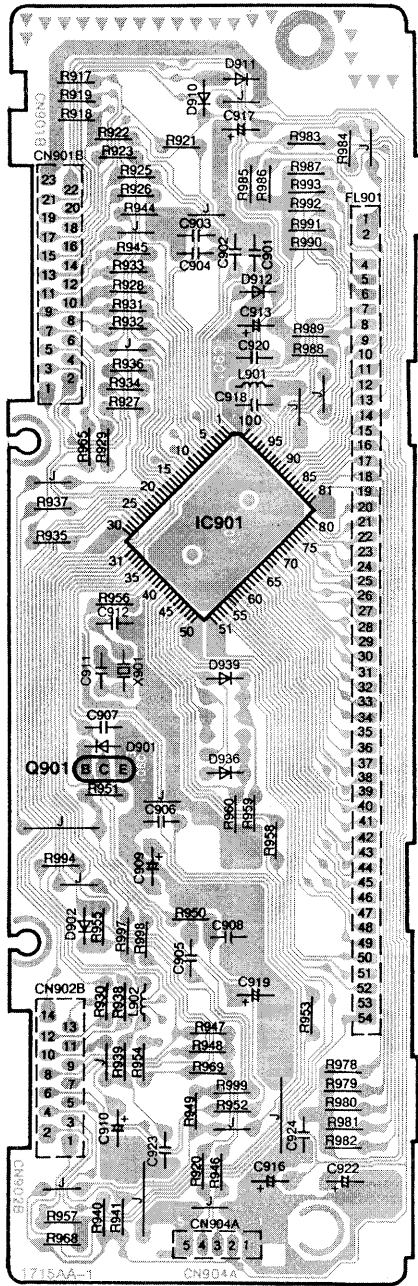

**F** OPERATION P.C.B.

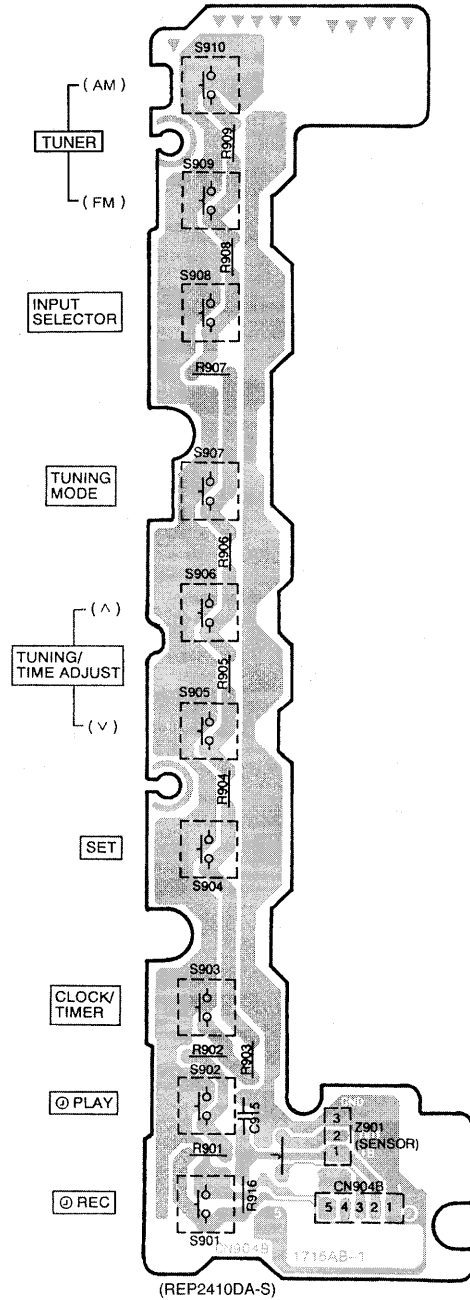

# ■ Wiring Connection Diagram

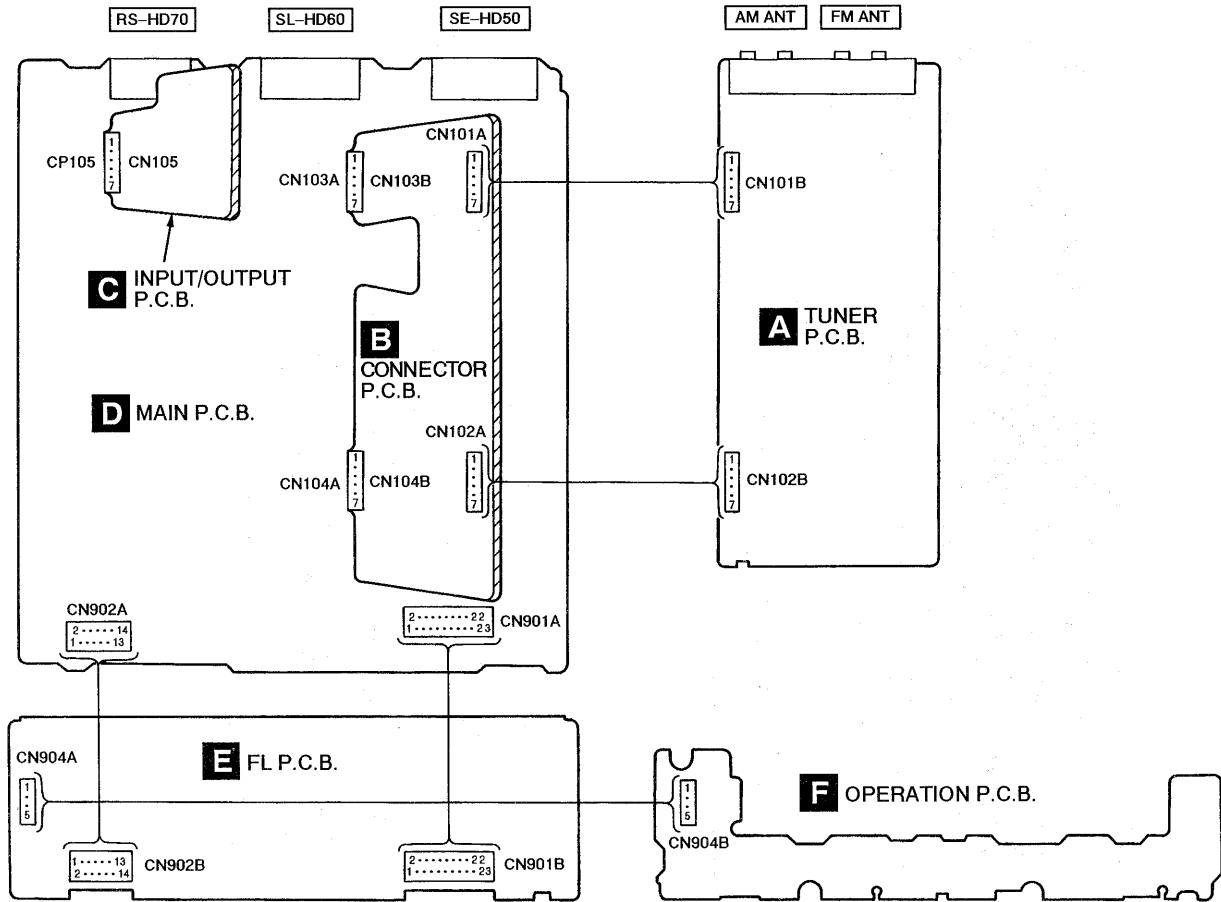

## ■ Terminal Function of IC's

### ● IC901 (M38197MA146F) : SYSTEM CONTROL/FL DRIVE

Pin No.	Terminal Name	I/O	Function
1	KEY-TU	I	Tuner operation switch signal input
2	KEY-CH	I	Input selector operation switch signal input
3	KEY-SE	I	SE-HD50 operation switch signal input
4	KEY-CD	I	SL-HD60 operation switch signal input
5	NC	-	Not used, open
6	DATA 1	O	Serial data output terminal
7	CLK 1	O	Serial clock signal output terminal
8	DATA 2	O	Serial data output terminal
9	CLK 2	O	Serial clock signal output terminal
10,11	NC	-	Not used, open
12	SEL-TU	O	Tuner select signal output
13	STB	O	Strobe signal output
14	NC	-	Not used, open
15	CE	O	Chip enable output
16	DATA IN	I	Serial data input terminal
17	CEO	O	Serial data output terminal for (E,EG) areas
18	DATA I/O	I/O	Not used, connected to GND
19	CD & DECK & MD CS	I	Serial data input terminal
20	CD & DECK & MD SCLK IN	I	Serial clock signal input terminal
21	CD & DECK & MD SDA OUT	O	Serial data output terminal
22	CD & DECK & MD SDA IN	I	Serial data input terminal
23	MD CS	I	Chip select signal input for MD
24	MD REQ	O	Request signal output for MD
25	DECK REQ	O	Request signal output for RS-HD70
26	CD REQ	O	Request signal output for SL-HD60
27	CHECK	O	Clock checking terminal
28	CR TIMER	I/O	Capacitor and resistor oscillation terminal
29	CEI	I	Serial data input terminal for (EG) area only
30	REMOCON	I	Remote control signal input
31	V-JOGB	I	Volume control signal input
32	V-JOGA	I	

Pin No.	Terminal Name	I/O	Function
33	ACK DK	I	Serial data input for RS-HD70
34	AC IN	I	AC power in detection signal input
35	RESET	I	Reset signal input
36	SD	I	SD control signal input for tuner circuit
37	STEREO	I	STEREO signal input for tuner circuit
38	XIN	I	Connected to the ceramic oscillator
39	XOUT	O	
40	Vss	-	GND terminal
41	MUTE	O	Muting control signal output
42	POWER	O	Power ON/OFF control signal output
43	CSI 2	I	Connect to GND through the resistor
44	CSI 1	I	
45,46	CSO 3, CSO2	O	Not used, open
47	CSO 1	O	Connect to GND through the diode
48-60	G13 ~ G1	O	Grid control signal output
61-90	P36 ~ P7	O	Segment control signal output
91	VCC	-	Power supply (+5V)
92-97	P6 ~ P1	O	Segment control signal output
98	-VP	-	Negative power supply
99	AVSS	-	Connected to GND
100	VREF	-	Reference voltage input terminal

# Block Diagram

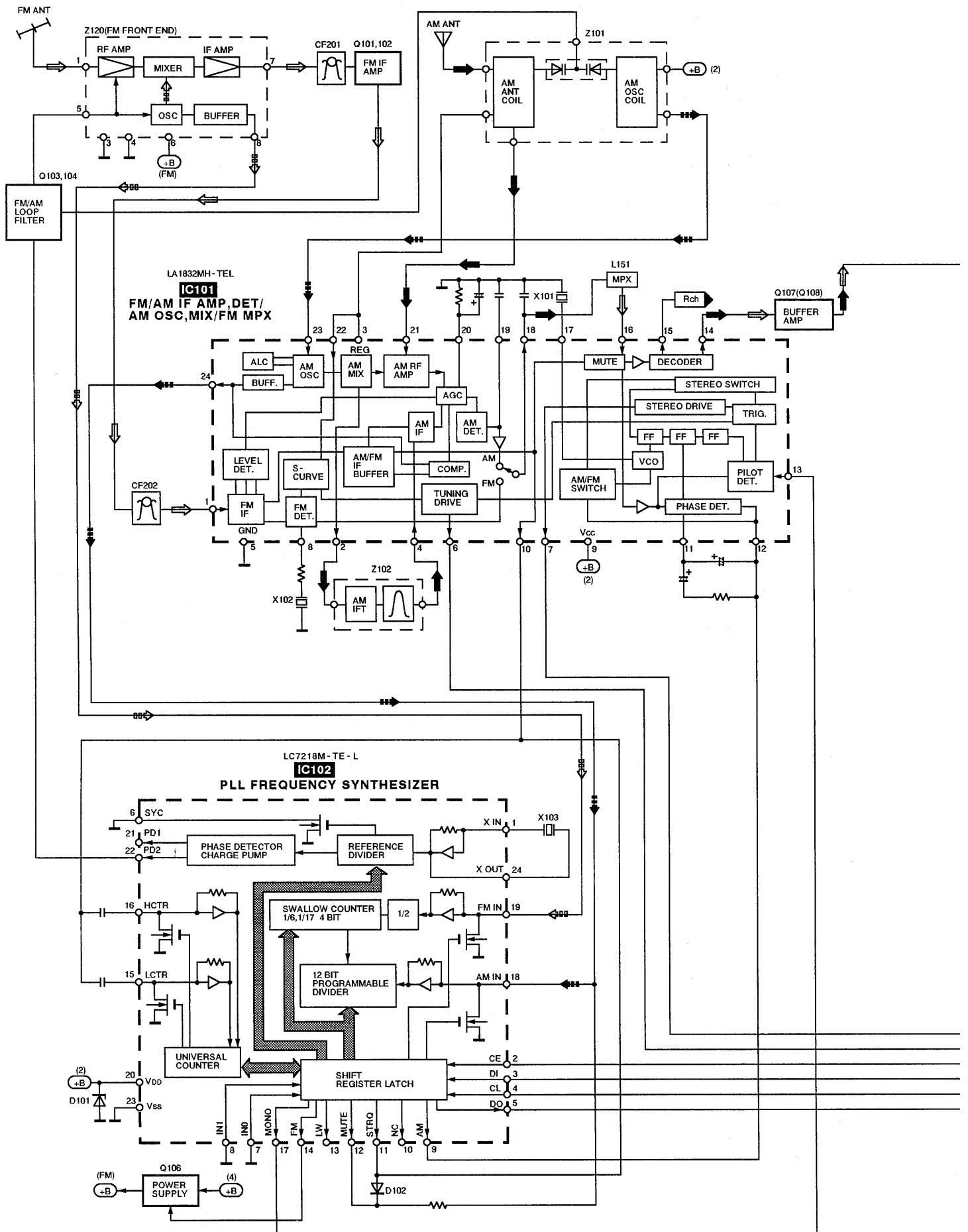

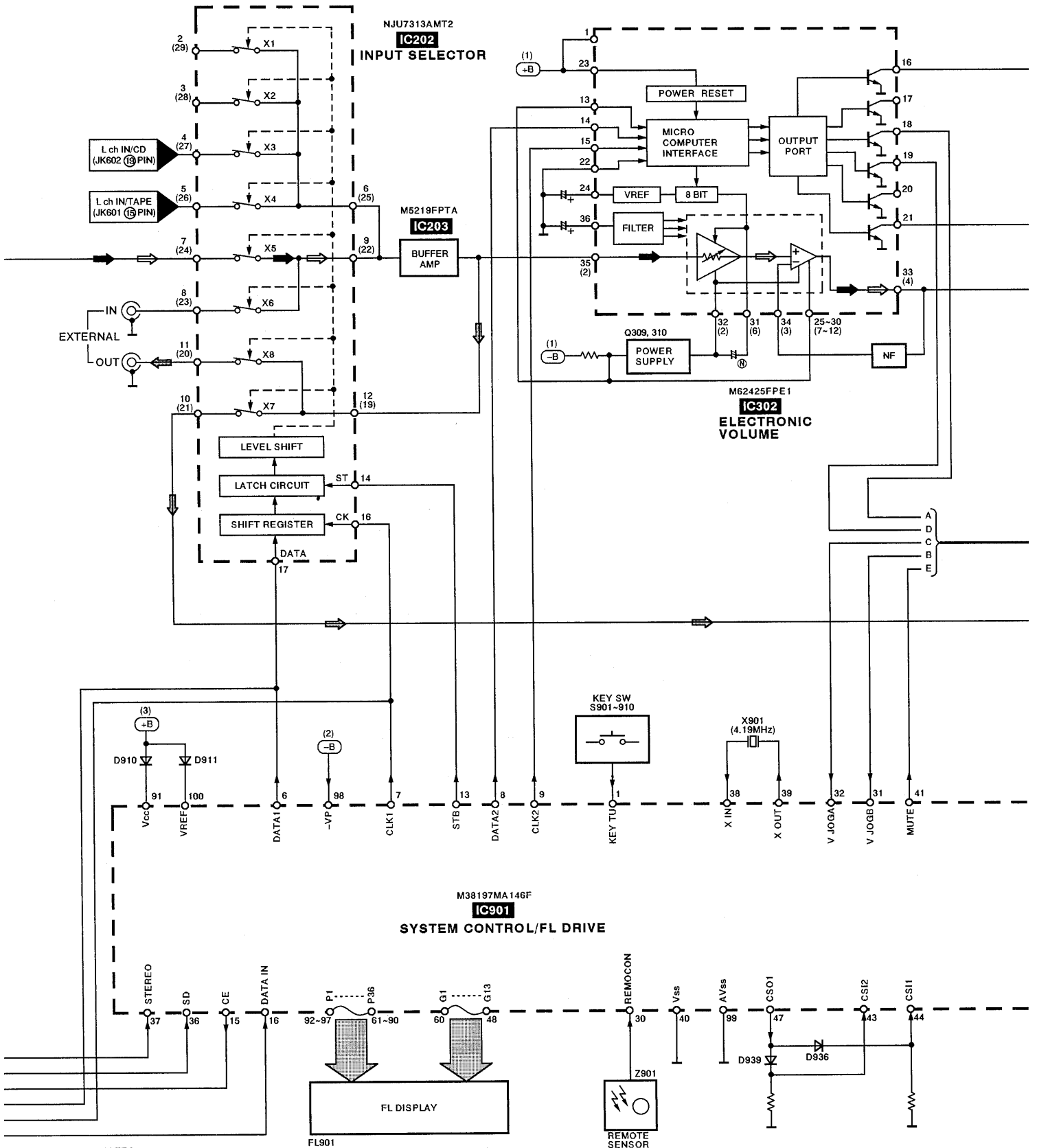

NOTES:  
 1)   
 [Symbol] : FM SIGNAL      [Symbol] : AM OSC SIGNAL  
 [Symbol] : AM SIGNAL      [Symbol] : REC OUT SIGNAL  
 [Symbol] : FM OSC SIGNAL  
 2) ( ) INDICATES Pin No. OF RIGHT CHANNEL.

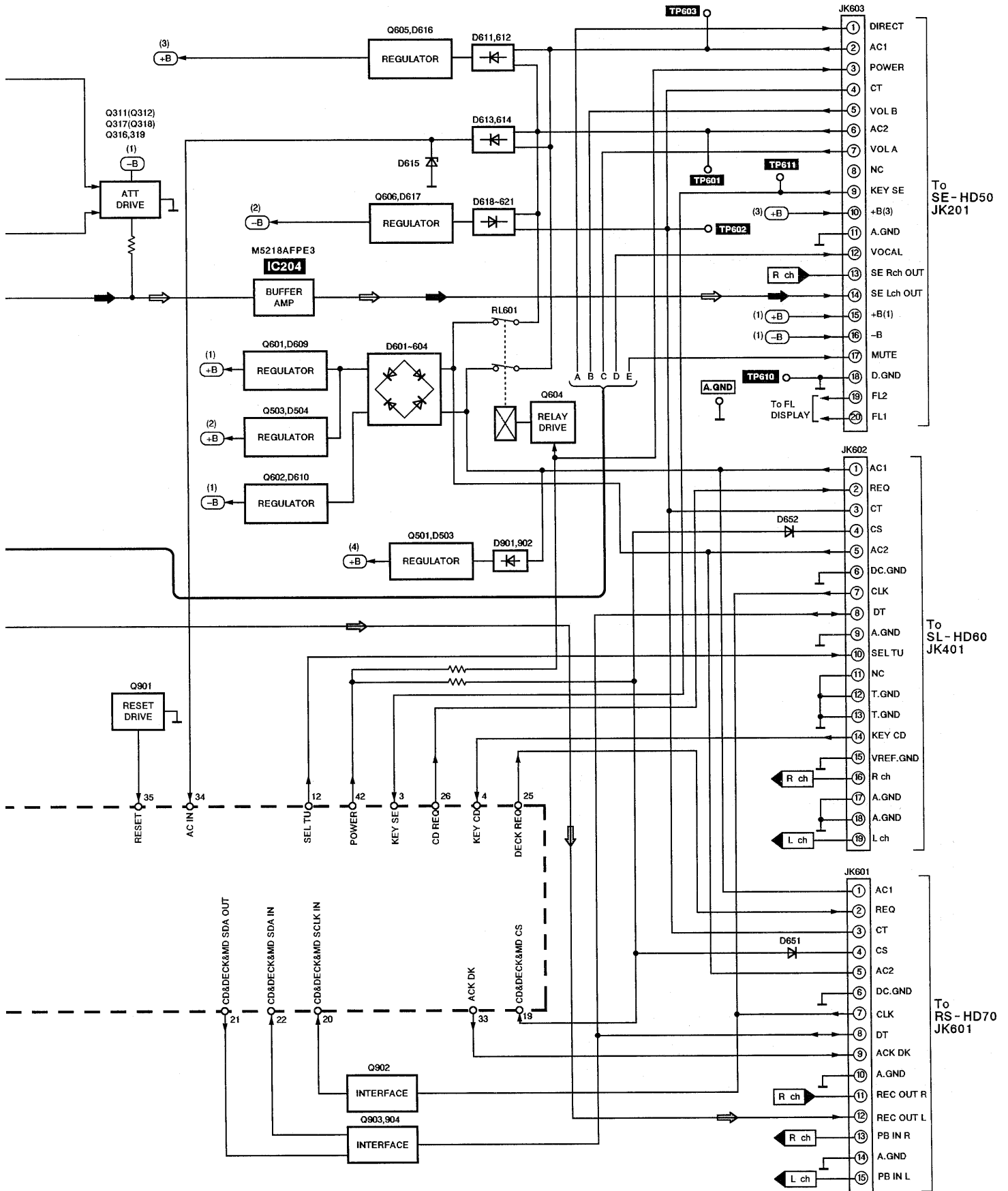

## ■ Replacement Parts List (Electrical)

**Notes:** \*Important safety notice:

Components identified by Δ mark have special characteristics important for safety.

Furthermore, special parts which have purposes of fire-retardant (resistors), high-quality sound (capacitors), low-noise (resistors), etc. are used.

When replacing any of components, be sure to use only manufacture's specified parts shown in the parts list.

\*The parenthesized indications in the Remarks columns specify the areas. (Refer to the cover page for area.)

Parts without these indications can be used for all areas.

\*[M] Indicates in Remarks column parts that are supplied by MESA.

Ref. No.	Part No.	Part Name & Description	Remarks	Ref. No.	Part No.	Part Name & Description	Remarks
		INTEGRATED CIRCUIT(S)		D613, 614△	MA185TA	DIODE	[M]
				D615△	MA4051MTA	DIODE	[M]
				D616△	MA4062-H	DIODE	[M]
IC101	LA1832MH-TEL	IC	[M]	D617△	MA4300M	DIODE	[M]
IC102	LC7218M-TE-L	IC	[M]	D618-621△	RL1N4003N02	DIODE	[M]
IC202	NJU7313AMT2	IC	[M]	D622△	MA4039MTA	DIODE	[M]
IC203	M5219FPTA	IC	[M]	D632	MA165	DIODE	[M]
IC204	M5218AFPE3	IC	[M]	D651, 652	MA165	DIODE	[M]
IC302	M62425FPE1	IC	[M]	D653	MA719TA	DIODE	[M]
IC901	M38197MA146F	IC	[M]	D901, 902	MA165	DIODE	[M]
		TRANSISTOR(S)		D910	1SS291TA	DIODE	[M]
				D911	MA165	DIODE	[M]
				D912	1SS291TA	DIODE	[M]
Q101, 102	2SC2787L	TRANSISTOR	[M]	D936	MA165	DIODE	[M]
Q103, 104	2SC2785FE	TRANSISTOR	[M]	D939	MA165	DIODE	[M]
Q106	UN411FTA	TRANSISTOR	[M]	D960	MA165	DIODE	[M]
Q107, 108	2SC3311AR	TRANSISTOR	[M]	D963, 964	MA165	DIODE	[M]
Q309, 310	2SA1309A-R	TRANSISTOR	[M]			COMPONENT COMBINATION(S)	
Q311, 312	2SC3311A-Q	TRANSISTOR	[M]	Z101	RLA2Z002M-T	COMPONENT COMBINATION	[M]
Q316	UN4115	TRANSISTOR	[M]	Z102	RLI2Z006M-T	COMPONENT COMBINATION	[M]
Q317, 318	2SC3311A-Q	TRANSISTOR	[M]	Z120	RAL0019	FM FRONT END	[M]
Q319	UN4115	TRANSISTOR	[M]	Z901	RCDGP1U90XA	REMOTE SENSOR	[M]
Q501△	2SC3940AQSTA	TRANSISTOR	[M]			COIL(S)	
Q503△	2SC3940AQSTA	TRANSISTOR	[M]	L101	ELESNR68MA	COIL	[M]
Q601△	2SD2137PQTA	TRANSISTOR	[M]	L103	ELEXTR47MA9	COIL	[M]
Q602△	2SB1417PQTA	TRANSISTOR	[M]	L105, 106	ELELN822KL	COIL	[M]
Q604	2SD2144S	TRANSISTOR	[M]	L151	SLM1B10M-1M	COIL	[M]
Q605△	2SD2137PQTA	TRANSISTOR	[M]	L191	ELESNR68MA	COIL	[M]
Q606△	2SB621A-R	TRANSISTOR	[M]	L601	ELEXT1R0KA9	COIL	[M]
Q901	UN4214TA	TRANSISTOR	[M]	L901	RLQA100JT-Y	COIL	[M]
Q902	DTC143XSTP	TRANSISTOR	[M]	L902	ELEXT1R0KA9	COIL	[M]
Q903, 904	2SC3311A-Q	TRANSISTOR	[M]			FILTER(S)	
		DIODE(S)		CF201	RLFFETNGD01L	CERAMIC FILTER	[M]
				CF202	RLFFETMGD01L	CERAMIC FILTER	[M]
D101△	MA4051MTA	DIODE	[M]			OSCILLATOR(S)	
D102	MA165	DIODE	[M]	X101	RSXZ456KM07M	OSCILLATOR	[M]
D301	MA165	DIODE	[M]	X102	RLFDGT05DD	OSCILLATOR	[M]
D501, 502△	MA185TA	DIODE	[M]	X103	RSXC7M20S05T	OSCILLATOR	[M]
D503△	MA4150M	DIODE	[M]				
D504△	MA4082LTA	DIODE	[M]				
D601-604△	RL1N4003N02	DIODE	[M]				
D605	MA165	DIODE	[M]				
D606, 607	MA719TA	DIODE	[M]				
D609, 610△	MA4082LTA	DIODE	[M]				
D611, 612△	RL1N4003N02	DIODE	[M]				

Ref. No.	Part No.	Part Name & Description	Remarks				
X901	RSXC4M19S02T	OSCILLATOR	[M]				
		DISPLAY TUBE					
FL901	RSL0225-F	DISPLAY TUBE	[M]				
		SWITCH(ES)					
S901-910	EVQ21405R	SW	[M]				
		CONNECTOR(S)					
CN105	RJU057W007	CONNECTOR (7P)	[M]				
CN101A	RJT057W007-1	CONNECTOR (7P)	[M]				
CN102A	RJT057W007-1	CONNECTOR (7P)	[M]				
CN103A	RJT057W007-1	CONNECTOR (7P)	[M]				
CN104A	RJT057W007-1	CONNECTOR (7P)	[M]				
CN901A	RJS1A6823	CONNECTOR (23P)	[M]				
CN902A	RJS1A6814	CONNECTOR (14P)	[M]				
CN904A	RJT066HD5A	CONNECTOR (5P)	[M]				
CN101B	RJU057W007	CONNECTOR (7P)	[M]				
CN102B	RJU057W007	CONNECTOR (7P)	[M]				
CN103B	RJU057W007	CONNECTOR (7P)	[M]				
CN104B	RJU057W007	CONNECTOR (7P)	[M]				
CN901B	RJS1A6223-1	CONNECTOR (23P)	[M]				
CN902B	RJS1A6214-1	CONNECTOR (14P)	[M]				
CN904B	RJU066HD5	CONNECTOR (5P)	[M]				
CP105	RJT057W007-1	CONNECTOR (7P)	[M]				
		GND PLATE					
E601, 602	SNE1004-2	GND PLATE	[M]				
		RELAY(S)					
RL601△	RSY0017M-0	RELAY	[M]				
		JACK(S)					
JK101	RJH5210M	ANT TERMINAL	[M]				
JK202	SJF3069-5N	EXT OUT/IN	[M]				
JK601	RJT065K15	CONNECTOR (15P)	[M]				
JK602	RJT065K19	CONNECTOR (19P)	[M]				
JK603	RJT065K20	CONNECTOR (20P)	[M]				



## Resistors and Capacitors

Notes: \*Capacity values are in microfarads ( $\mu\text{F}$ ) unless specified otherwise, P = Pico-farads (pF) F = Farads (F)  
 \*Resistance values are in ohms, unless specified otherwise, 1K = 1,000 (OHM) 1M = 1,000K (OHM)  
 \*[M] Indicates in Remarks columns parts that are supplied by MESA.

Ref. No.	Part No.	Values & Remarks	Ref. No.	Part No.	Values & Remarks	Ref. No.	Part No.	Values & Remarks
		RESISTORS	R239-244	ERDS2TJ102	1/4W 1K [M]	R637, 638	ERDS2TJ150T	1/4W 15 [M]
			R331, 332	ERDS2TJ102	1/4W 1K [M]	R641, 642	ERDS2TJ471	1/4W 470 [M]
			R333, 334	ERDS2TJ104	1/4W 100K [M]	R656	ERDS2TJ221	1/4W 220 [M]
R103	ERDS2TJ330	1/4W 33 [M]	R335, 336	ERDS2TJ562	1/4W 5.6K [M]	R901	ERDS2TJ821	1/4W 820 [M]
R104	ERDS2TJ103	1/4W 10K [M]	R337, 338	ERDS2TJ123	1/4W 12K [M]	R902	ERDS2TJ102	1/4W 1K [M]
R105	ERDS2TJ471	1/4W 470 [M]	R339, 340	ERDS2TJ471	1/4W 470 [M]	R903	ERDS2TJ122	1/4W 1.2K [M]
R106	ERDS2TJ474	1/4W 470K [M]	R341, 342	ERDS2TJ122	1/4W 1.2K [M]	R904	ERDS2TJ152	1/4W 1.5K [M]
R107	ERDS2TJ331	1/4W 330 [M]	R343, 344	ERDS2TJ224T	1/4W 220K [M]	R905	ERDS2TJ182	1/4W 1.8K [M]
R108	ERDS2TJ474	1/4W 470K [M]	R345-348	ERDS2TJ103	1/4W 10K [M]	R906	ERDS2TJ222	1/4W 2.2K [M]
R109	ERDS2TJ331	1/4W 330 [M]	R349, 350	ERDS2TJ102	1/4W 1K [M]	R907	ERDS2TJ332	1/4W 3.3K [M]
R110	ERDS2TJ102	1/4W 1K [M]	R351	ERDS2TJ182	1/4W 1.8K [M]	R908	ERDS2TJ472	1/4W 4.7K [M]
R112	ERDS2TJ104	1/4W 100K [M]	R352	ERDS2TJ102	1/4W 1K [M]	R909	ERDS2TJ682T	1/4W 6.8K [M]
R113	ERDS2TJ103	1/4W 10K [M]	R353	ERDS2TJ182	1/4W 1.8K [M]	R911	ERDS2TJ473	1/4W 47K [M]
R114	ERDS2TJ562	1/4W 5.6K [M]	R354, 355	ERDS2TJ222	1/4W 2.2K [M]	R916-919	ERDS2TJ103	1/4W 10K [M]
R115	ERDS2TJ561	1/4W 560 [M]	R356-358	ERDS2TJ391	1/4W 390 [M]	R920-922	ERDS2TJ102	1/4W 1K [M]
R116	ERDS2TJ102	1/4W 1K [M]	R361, 362	ERDS2TJ223	1/4W 22K [M]	R923	ERDS2TJ391	1/4W 390 [M]
R117	ERDS2TJ823T	1/4W 82K [M]	R363, 364	ERDS2TJ102	1/4W 1K [M]	R925	ERDS2TJ102	1/4W 1K [M]
R118	ERDS2TJ562	1/4W 5.6K [M]	R365, 366	ERDS2TJ105T	1/4W 1M [M]	R926, 927	ERDS2TJ101	1/4W 100 [M]
R119	ERDS2TJ822	1/4W 8.2K [M]	R372	ERDS2TJ105T	1/4W 1M [M]	R928	ERDS2TJ102	1/4W 1K [M]
R120	ERDS2TJ473	1/4W 47K [M]	R374	ERDS2TJ182	1/4W 1.8K [M]	R929	ERDS2TJ101	1/4W 100 [M]
R121	ERDS2TJ332	1/4W 3.3K [M]	R375, 376	ERDS2TJ102	1/4W 1K [M]	R930-933	ERDS2TJ102	1/4W 1K [M]
R122	ERDS2TJ272T	1/4W 2.7K [M]	R377, 378	ERDS2EJ121	1/4W 120 [M]	R934	ERDS2TJ101	1/4W 100 [M]
R124	ERDS2TJ271	1/4W 270 [M]	R379, 380	ERDS2TJ223	1/4W 22K [M]	R935	ERDS2TJ102	1/4W 1K [M]
R125, 126	ERDS2TJ152	1/4W 1.5K [M]	R381	ERDS2TJ105T	1/4W 1M [M]	R936, 937	ERDS2TJ101	1/4W 100 [M]
R127	ERDS2TJ103	1/4W 10K [M]	R382	ERDS2TJ472	1/4W 4.7K [M]	R938	ERDS2TJ102	1/4W 1K [M]
R128	ERDS2TJ820	1/4W 82 [M]	R383	ERDS2TJ223	1/4W 22K [M]	R939	ERDS2TJ101	1/4W 100 [M]
R129	ERDS2TJ473	1/4W 47K [M]	R397, 398	ERQ16NKW2R2E	1/6W 2.2 [M]	R940, 941	ERDS2TJ393	1/4W 39K [M]
R130	ERDS2TJ103	1/4W 10K [M]	R501	ERDS2TJ152	1/4W 1.5K [M]	R942	ERDS2TJ472	1/4W 4.7K [M]
R132	ERDS2TJ103	1/4W 10K [M]	R502	ERDS2TJ221	1/4W 220 [M]	R944	ERDS2TJ473	1/4W 47K [M]
R133-137	ERDS2TJ102	1/4W 1K [M]	R506	ERDS2TJ152	1/4W 1.5K [M]	R945, 946	ERDS2TJ102	1/4W 1K [M]
R138	ERDS2TJ103	1/4W 10K [M]	R507	ERDS2TJ221	1/4W 220 [M]	R947-949	ERDS2TJ103	1/4W 10K [M]
R139, 140	ERDS2TJ272T	1/4W 2.7K [M]	R508, 509	ERDS2TJ223	1/4W 22K [M]	R950	ERDS2TJ102	1/4W 1K [M]
R141, 142	ERDS2TJ102	1/4W 1K [M]	R511, 512	ERDS2TJ472	1/4W 4.7K [M]	R951	ERDS2TJ104	1/4W 100K [M]
R143, 144	ERDS2TJ222	1/4W 2.2K [M]	R601, 602 $\Delta$	ERD2FCVJ4R7T	1/4W 4.7 [M]	R952, 953	ERDS2TJ102	1/4W 1K [M]
R145, 146	ERDS2TJ821	1/4W 820 [M]	R603, 604	ERDS2TJ102	1/4W 1K [M]	R954	ERDS2TJ101	1/4W 100 [M]
R147, 148	ERDS2TJ474	1/4W 470K [M]	R605	ERDS2TJ101	1/4W 100 [M]	R955	ERDS2TJ824	1/4W 820K [M]
R149	ERDS2TJ680T	1/4W 68 [M]	R606	ERDS2TJ393	1/4W 39K [M]	R956	ERDS2TJ101	1/4W 100 [M]
R171, 172	ERDS2TJ102	1/4W 1K [M]	R607	ERDS2TJ153	1/4W 15K [M]	R957	ERDS2TJ102	1/4W 1K [M]
R173	ERDS2TJ471	1/4W 470 [M]	R609 $\Delta$	ERQ16NKW2R2E	1/6W 2.2 [M]	R958	ERDS2TJ471	1/4W 470 [M]
R175	ERDS2TJ102	1/4W 1K [M]	R610	ERDS2TJ222	1/4W 2.2K [M]	R959, 960	ERDS2TJ223	1/4W 22K [M]
R176	ERDS2TJ391	1/4W 390 [M]	R612	ERDS2TJ472	1/4W 4.7K [M]	R961	ERDS2TJ103	1/4W 10K [M]
R205, 206	ERDS2TJ224T	1/4W 220K [M]	R613, 614	ERDS2TJ682T	1/4W 6.8K [M]	R962	ERDS2TJ473	1/4W 47K [M]
R207, 208	ERDS2TJ102	1/4W 1K [M]	R615	ERDS2TJ103	1/4W 10K [M]	R963, 964	ERDS2TJ103	1/4W 10K [M]
R209-212	ERDS2TJ822	1/4W 8.2K [M]	R616 $\Delta$	ERD25FVJ4R7T	1/4W 4.7 [M]	R965	ERDS2TJ472	1/4W 4.7K [M]
R225, 226	ERDS2TJ122	1/4W 1.2K [M]	R621, 622	ERDS2TJ151	1/4W 150 [M]	R966	ERDS2TJ223	1/4W 22K [M]
R229-231	ERDS2TJ222	1/4W 2.2K [M]	R623, 624	ERDS2TJ224T	1/4W 220K [M]	R967	ERDS2TJ472	1/4W 4.7K [M]
R233, 234	ERDS2TJ223	1/4W 22K [M]	R627-630	ERDS2TJ472	1/4W 4.7K [M]	R968, 969	ERDS2TJ152	1/4W 1.5K [M]
R235, 236	ERDS2TJ822	1/4W 8.2K [M]	R631, 632	ERDS2TJ471	1/4W 470 [M]	R970	ERDS2TJ473	1/4W 47K [M]
R237, 238	ERDS2TJ123	1/4W 12K [M]	R635, 636	ERDS2TJ472	1/4W 4.7K [M]	R971	ERDS2TJ104	1/4W 100K [M]

Ref. No.	Part No.	Values & Remarks	Ref. No.	Part No.	Values & Remarks	Ref. No.	Part No.	Values & Remarks
R978-993	ERDS2TJ104	1/4W 100K [M]	C237, 238	ECBT1H470J5	50V 47P [M]	C907	ECBT1H104ZF5	50V 0.1U [M]
R994	ERDS2TJ102	1/4W 1K [M]	C321, 322	ECBT1E103ZF	25V 0.01U [M]	C908	ECBT1E103ZF	25V 0.01U [M]
R997-999	ERDS2TJ102	1/4W 1K [M]	C323, 324	ECBT1H102KB5	50V 1000P [M]	C909	ECEA1HKA2R2B	50V 2.2U [M]
			C325, 326	ECBT1H101KB5	50V 100P [M]	C910	RCE1CKA100BG	16V 10U [M]
		CAPACITORS	C327, 328	RCE1AKA470BG	10V 47U [M]	C911	ECBT1H270JU5	50V 27P [M]
			C333, 334	ECBT1H221KB5	50V 220P [M]	C912	ECBT1H220GC5	50V 22P [M]
C101	ECBT1C103NS5	16V 0.01U [M]	C335, 336	RCE1CKA100BG	16V 10U [M]	C913	ECEA1VKA470B	35V 47U [M]
C103	ECBT1C103NS5	16V 0.01U [M]	C337, 338	ECEA1CKA220B	16V 22U [M]	C915	ECBT1E103ZF	25V 0.01U [M]
C104, 105	ECBT1H102KB5	50V 1000P [M]	C339, 340	RCE1CKA100BG	16V 10U [M]	C916, 917	ECEA1HKA010B	50V 1U [M]
C106	ECBT1C103NS5	16V 0.01U [M]	C341, 342	ECEA1AKN100B	10V 10U [M]	C918	ECBT1C105ZF5	16V 1U [M]
C107	ECBT1H473ZF5	50V 0.047U [M]	C343	RCE1CKA100BG	16V 10U [M]	C919	RCE0JU102BV	6.3V 1000U [M]
C108	ECBT1H8R2KC5	50V 8.2P [M]	C344, 345	ECBT1H470J5	50V 47P [M]	C920	ECBT1E103ZF	25V 0.01U [M]
C109, 110	ECBT1C103NS5	16V 0.01U [M]	C348	ECEA1CKA330B	16V 33U [M]	C922	ECEA0JKA221B	6.3V 220U [M]
C111	ECEA1EKA4R7B	25V 4.7U [M]	C350	ECEA0JKA470B	6.3V 47U [M]	C923	ECBT1H101KB5	50V 100P [M]
C112	ECBT1C103NS5	16V 0.01U [M]	C351, 352	RCE1CKA100BG	16V 10U [M]	C924	ECBT1H102KB5	50V 1000P [M]
C113	ECBT1H102KB5	50V 1000P [M]	C355	ECEA1CKA330B	16V 33U [M]	C954-957	ECBT1H101KB5	50V 100P [M]
C114	RCE1HKA3R3BG	50V 3.3U [M]	C356	ECBT1H104ZF5	50V 0.1U [M]			
C115	ECEA1EKA4R7B	25V 4.7U [M]	C357	RCE1AKA101BG	10V 100U [M]			
C116	ECBT1C822KS5	16V 8200P [M]	C365	ECEA0JKA470B	6.3V 47U [M]			
C117	ECQP1391JZ	100V 390P [M]	C391, 392	ECEA1CKA101B	16V 100U [M]			
C118, 119	ECFR1C103KR	16V 0.01U [M]	C393, 394	ECBT1H102KB5	50V 1000P [M]			
C120, 121	ECEA1HKA010B	50V 1U [M]	C501	ECEA1EKA101B	25V 100U [M]			
C122	ECEA1HKA2R2B	50V 2.2U [M]	C502	ECA1VM101B	35V 100U [M]			
C123	ECEA1HKA010B	50V 1U [M]	C503	ECBT1E103ZF	25V 0.01U [M]			
C124	ECBT1H102KB5	50V 1000P [M]	C504	ECEA1EKA101B	25V 100U [M]			
C125	ECBT1H150JC5	50V 15P [M]	C509	ECBT1E103ZF	25V 0.01U [M]			
C126	ECBT1H473ZF5	50V 0.047U [M]	C510	RCE1AKA101BG	10V 100U [M]			
C127	ECEA1CKA220B	16V 22U [M]	C513-515	ECBT1H102KB5	50V 1000P [M]			
C128	ECBT1H102KB5	50V 1000P [M]	C601, 602	ECKT1H223ZF	50V 0.022U [M]			
C129, 130	ECEA0JKA101B	6.3V 100U [M]	C603△	ECA1EM102B	25V 1000U [M]			
C132	ECBT1H102KB5	50V 1000P [M]	C604△	RCE1EM471BV	25V 470U [M]			
C133, 134	ECBT1H270JU5	50V 27P [M]	C605, 606	ECBT1E103ZF	25V 0.01U [M]			
C135, 136	ECBT1C103KS5	16V 0.01U [M]	C607, 608	RCE1AKA470BG	10V 47U [M]			
C137, 138	ECBT1H561KB5	50V 560P [M]	C609	ECBT1H102KB5	50V 1000P [M]			
C139, 140	ECBT1C682KR5	16V 6800P [M]	C610, 611	ECBT1H104ZF5	50V 0.1U [M]			
C141-144	ECEA1HKA010B	50V 1U [M]	C612	RCE1EM471BV	25V 470U [M]			
C145	ECBT1H220JC5	50V 22P [M]	C613	ECBT1E103ZF	25V 0.01U [M]			
C148	ECBT1C103NS5	16V 0.01U [M]	C614	RCE1AKA470BG	10V 47U [M]			
C149	ECBT1H104ZF5	50V 0.1U [M]	C615	ECEA1EKA101B	25V 100U [M]			
C171, 172	ECBT1H102KB5	50V 1000P [M]	C616	ECA1HM470B	50V 47U [M]			
C173	ECEA1CKA220B	16V 22U [M]	C617△	ECA1HM470B	50V 47U [M]			
C174	RCE1CKA100BG	16V 10U [M]	C618△	ECA2AM470B	100V 47U [M]			
C181	ECBT1H471KB5	50V 470P [M]	C619	ECKR1H103ZF5	50V 0.01U [M]			
C196	ECBT1H102KB5	50V 1000P [M]	C620	RCE1VKA100BG	35V 10U [M]			
C205-208	ECBT1H101KB5	50V 100P [M]	C623	RCE1AKA101BG	10V 100U [M]			
C209, 210	ECBT1H180J5	50V 18P [M]	C624	ECEA1VKA470B	35V 47U [M]			
C211	ECBT1H102KB5	50V 1000P [M]	C631-636	ECBT1H101KB5	50V 100P [M]			
C223, 224	ECBT1H104ZF5	50V 0.1U [M]	C651, 652	ECBT1H104ZF5	50V 0.1U [M]			
C225-227	ECBT1H470J5	50V 47P [M]	C655	ECQV1H224JM3	50V 0.22U [M]			
C231, 232	ECBT1E103ZF	25V 0.01U [M]	C656	ECQV1H474JM3	50V 0.47U [M]			
C233, 234	ECBT1H102KB5	50V 1000P [M]	C901-904	ECBT1H471KB5	50V 470P [M]			
C235, 236	ECBT1H101KB5	50V 100P [M]	C905, 906	ECBT1H102KB5	50V 1000P [M]			



# ■ Cabinet Parts Location

