

A TUNER CIRCUIT

: POSITIVE VOLTAGE LINE
 : FM SIGNAL LINE
 : AM SIGNAL LINE
 : FM OSC SIGNAL LINE
 : AM OSC SIGNAL LINE

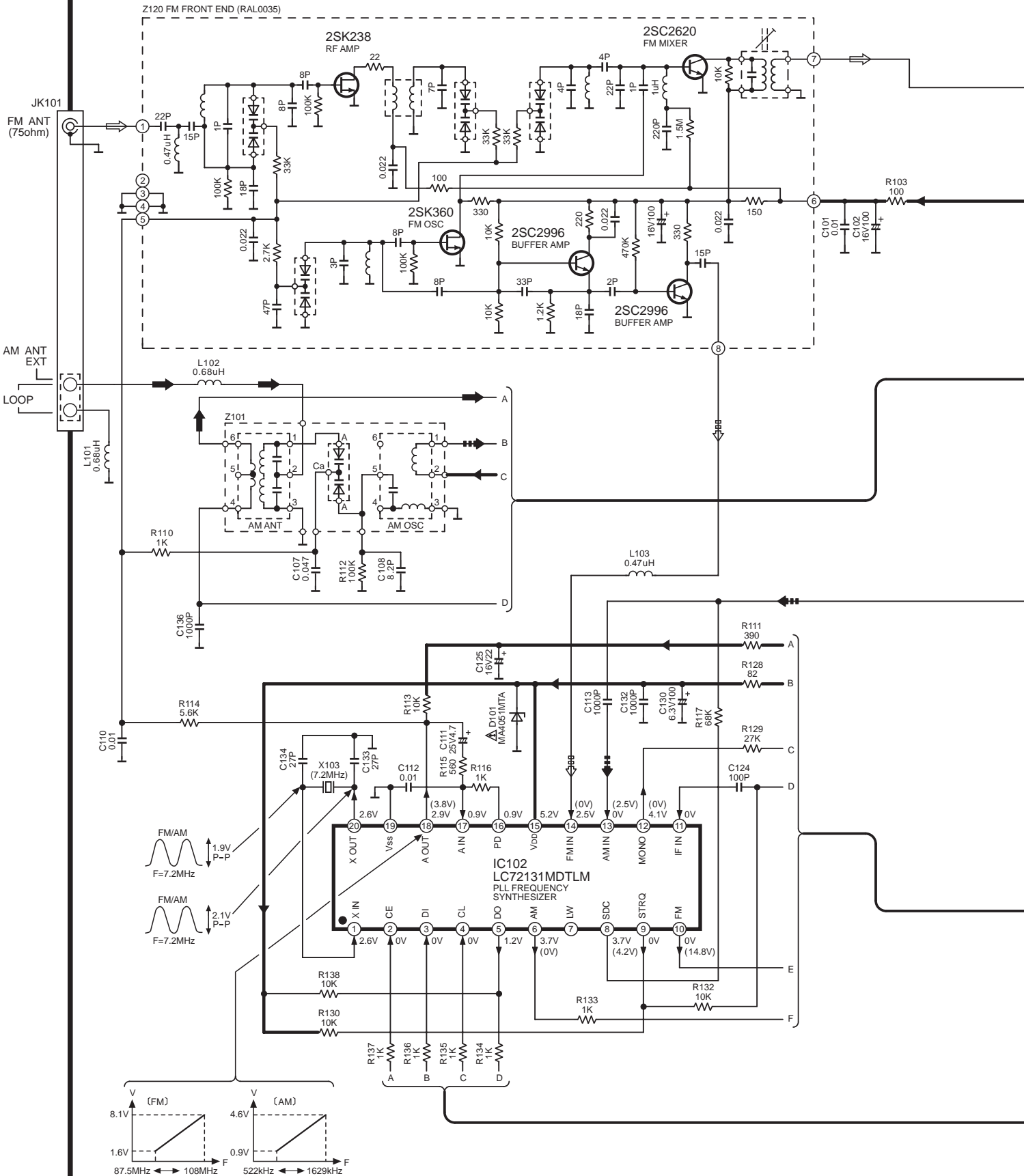

➔ : POSITIVE VOLTAGE LINE ➞ : FM SIGNAL LINE ➡ : AM SIGNAL LINE ■■ : AM OSC SIGNAL LINE

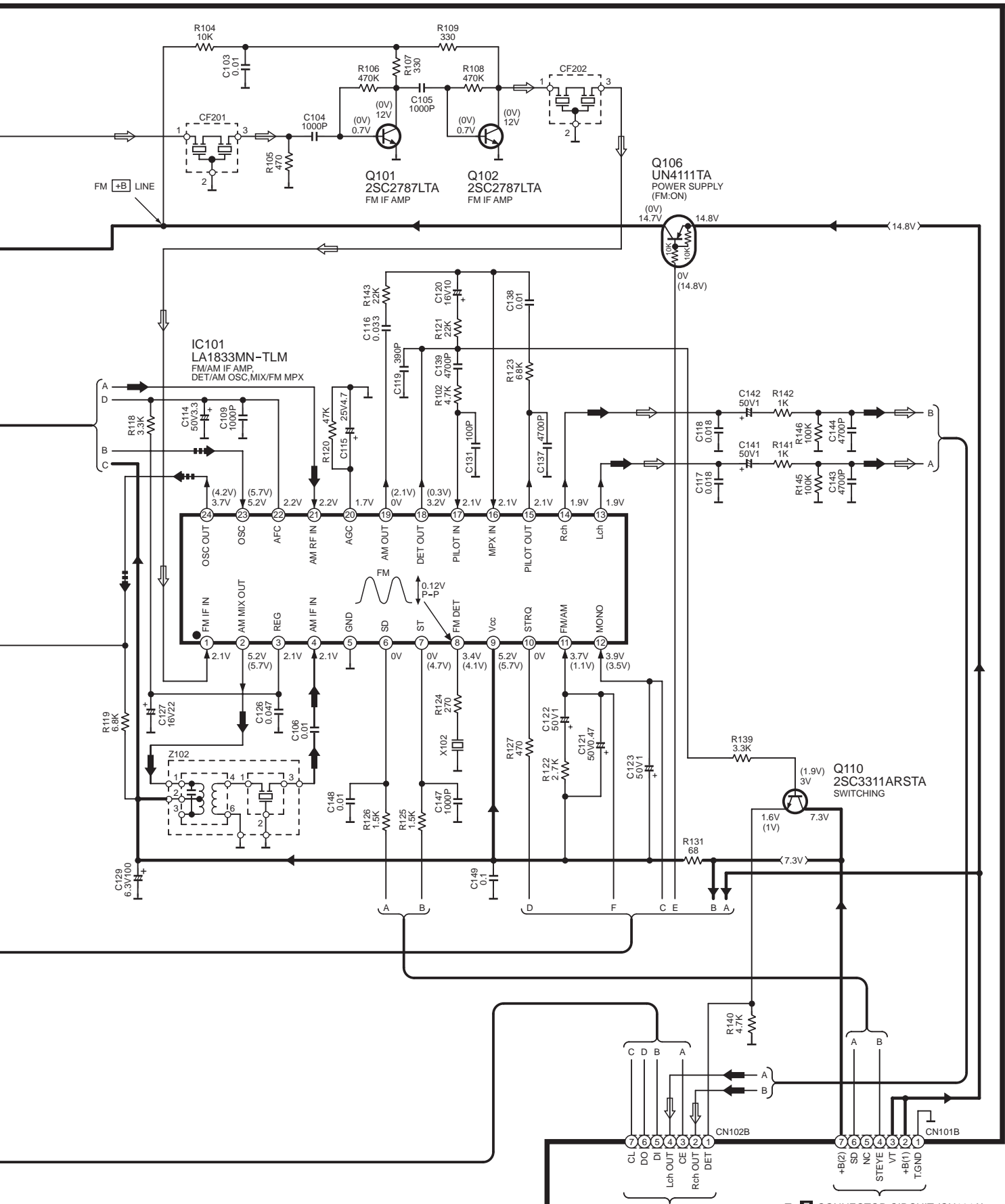

To **E** CONNECTOR CIRCUIT (CN102A) on SCHEMATIC DIAGRAM-4 To **E** CONNECTOR CIRCUIT (CN101A) on SCHEMATIC DIAGRAM-4

B FL CIRCUIT

→ : POSITIVE VOLTAGE LINE

- → : NEGATIVE VOLTAGE LINE

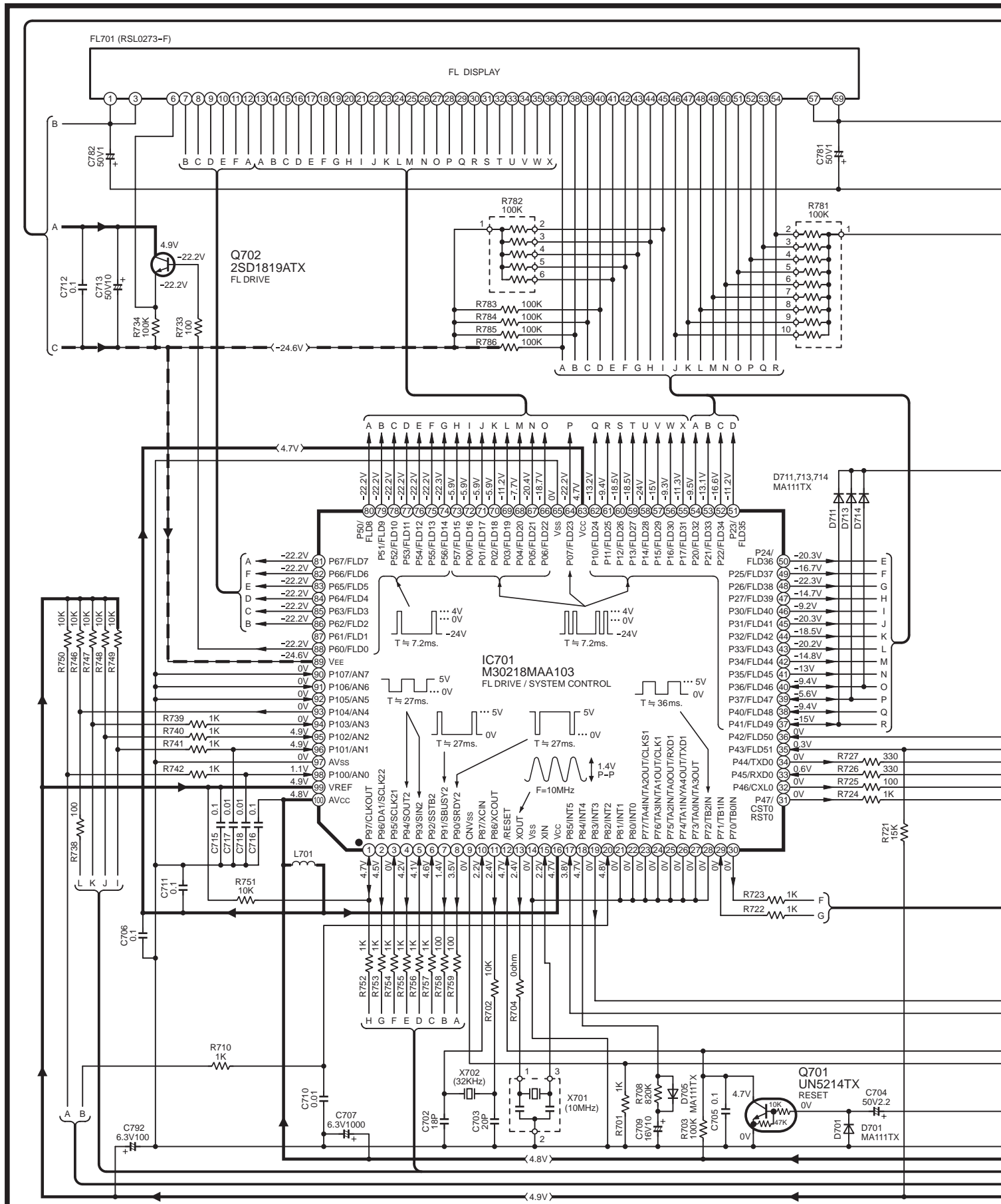

C OPERATION CIRCUIT

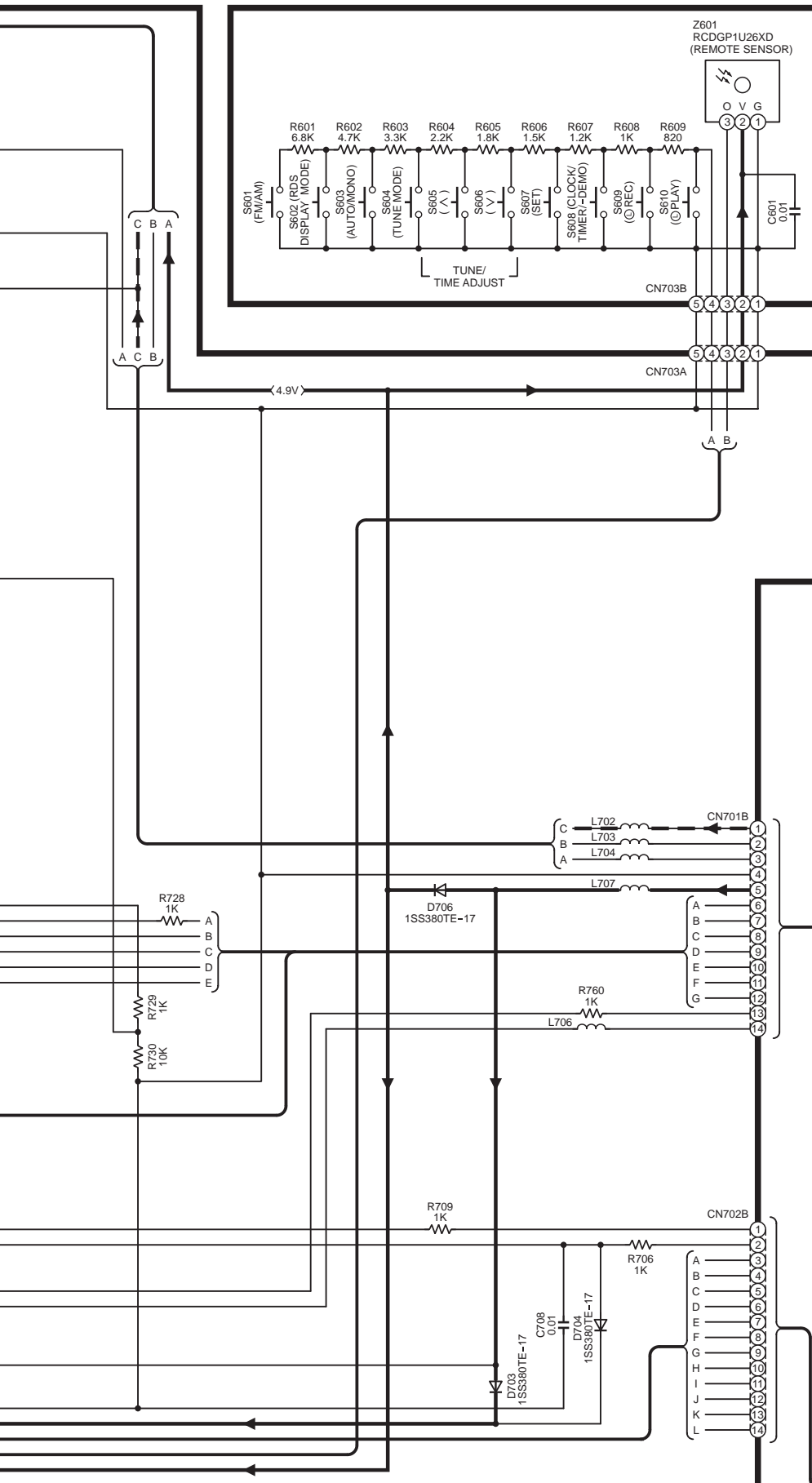

D IN/OUT TERMINAL CIRCUIT

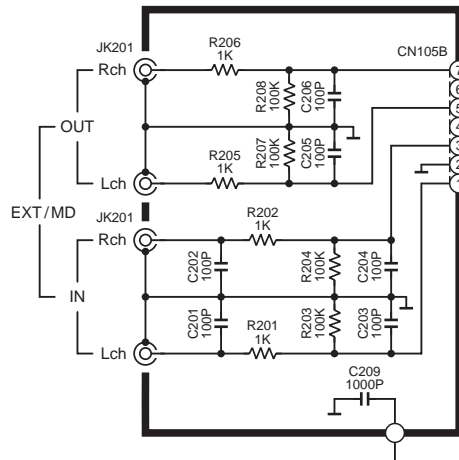

- ▶— : POSITIVE VOLTAGE LINE
- -▶- - : NEGATIVE VOLTAGE LINE
- ⇨ : FM SIGNAL LINE
- ▶ : AM SIGNAL LINE

E CONNECTOR CIRCUIT

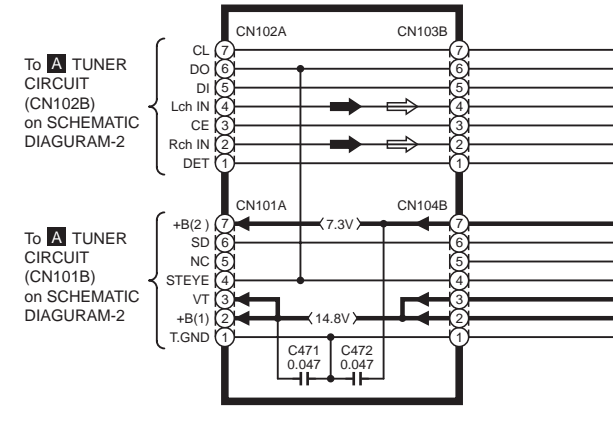

F MAIN CIRCUIT

→ : POSITIVE VOLTAGE LINE - - - - - : NEGATIVE VOLTAGE LINE ⇨ : FM SIGNAL LINE ⇨ : AM SIGNAL LINE

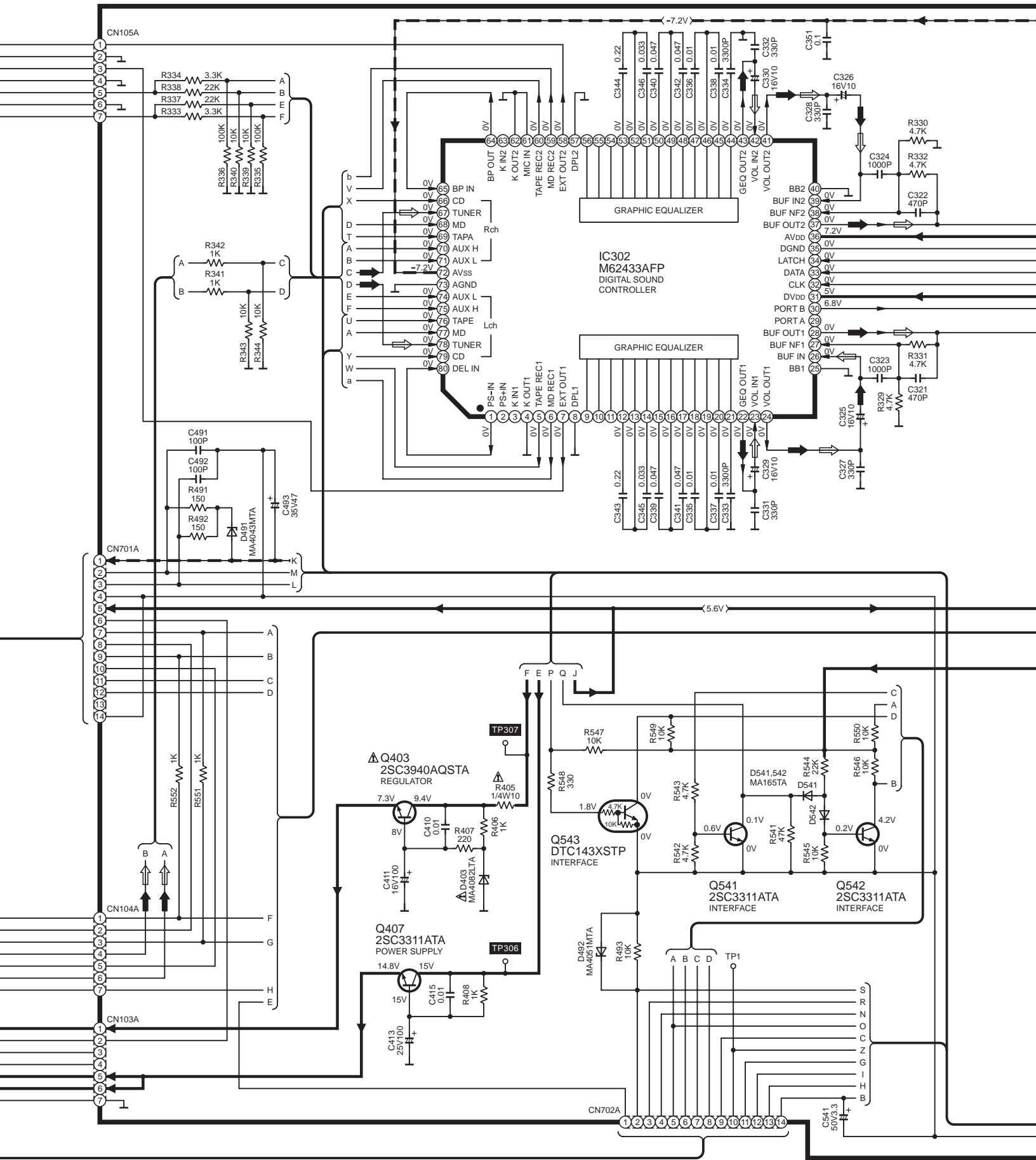

→ : POSITIVE VOLTAGE LINE - - - - - : NEGATIVE VOLTAGE LINE ⇨ : FM SIGNAL LINE ⇨ : AM SIGNAL LINE

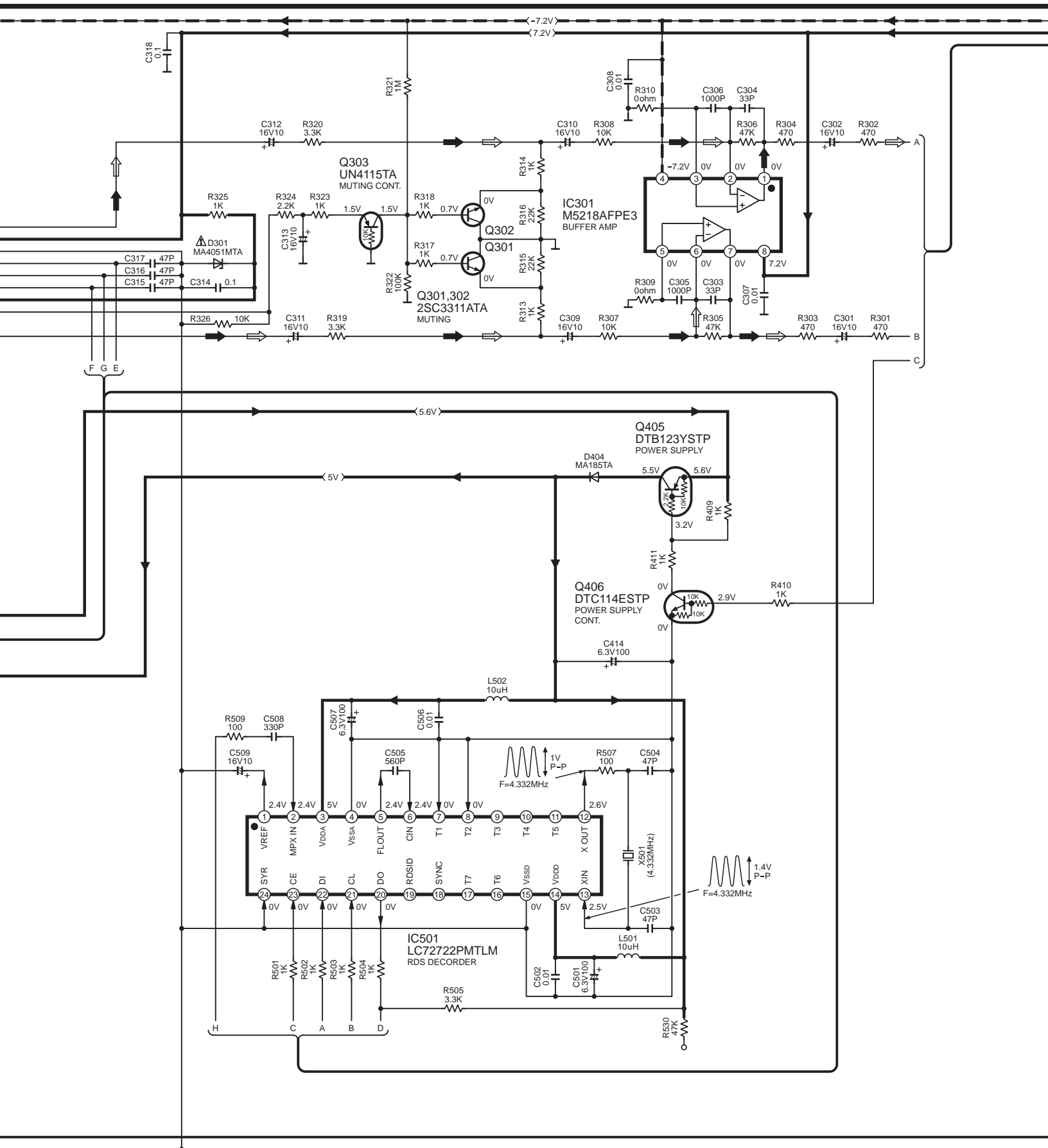

H MAIN CIRCUIT

:NEGATIVE VOLTAGE LINE
 :FM SIGNAL LINE
 :POSITIVE VOLTAGE LINE
 :AM SIGNAL LINE

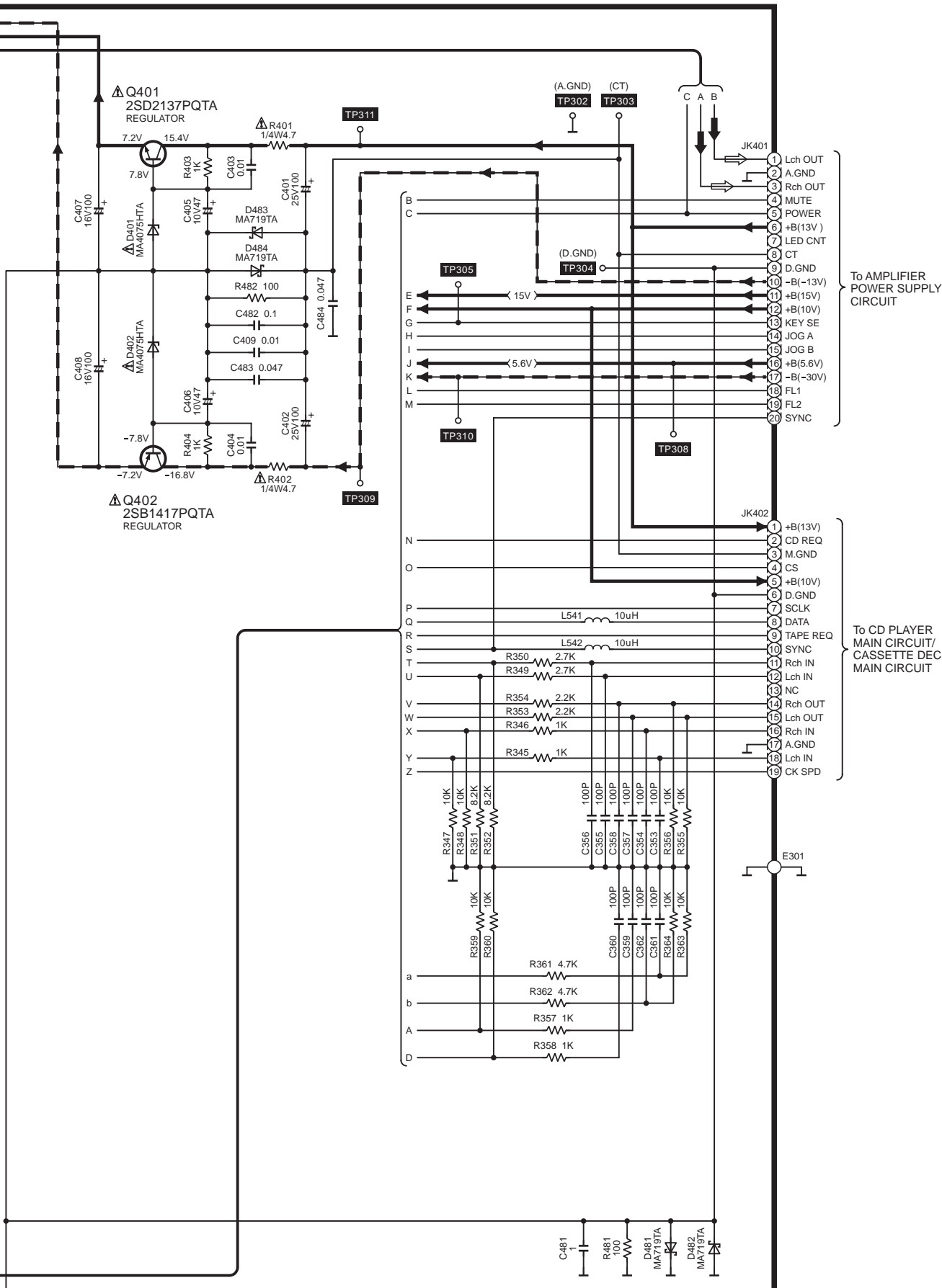

To AMPLIFIER
POWER SUPPLY
CIRCUIT

To CD PLAYER
MAIN CIRCUIT/
CASSETTE DECK
MAIN CIRCUIT

A

B

C

D

E

F

1

A TUNER P.C.B.

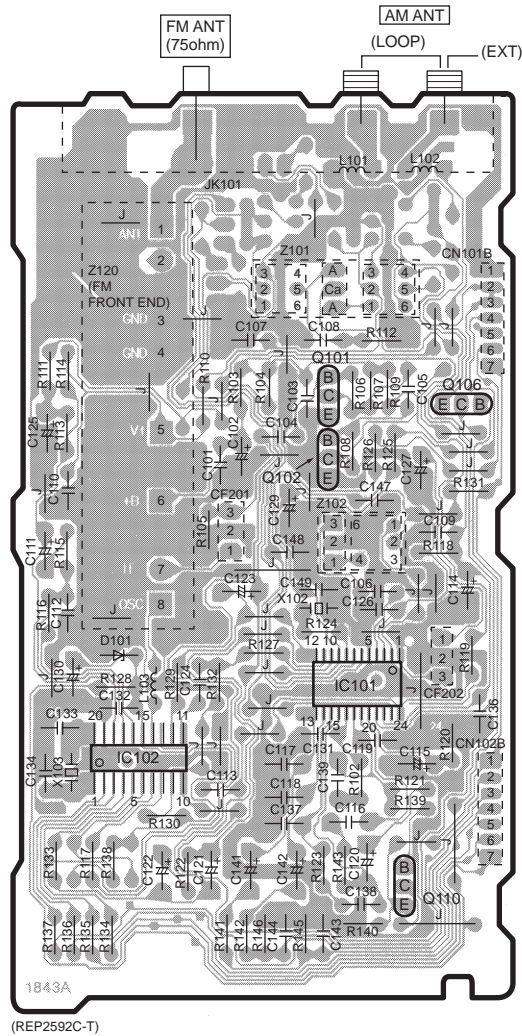

ELECTRICAL PARTS LOCATION

Ref. No.	Lo. No.	Ref. No.	Lo. No.
A TUNER P.C.B.			
IC101	4C	R136	5B
IC102	5B	R137	5B
Q101	3C	R138	5B
Q102	3C	R139	5C
Q106	3D	R140	5C
Q110	5C	R141	5C
D101	4B	R142	5C
L101	2C	R143	5C
L102	2C	R145	5C
L103	4B	R146	5C
Z101	2C	C101	3C
Z102	4C	C102	3C
Z120	3B	C103	3C
CF201	3C	C104	3C
CF202	4D	C105	3C
X102	4C	C106	4C
X103	5B	C107	3C
CN101B	3D	C108	3C
CN102B	5D	C109	4D
JK101	2C	C110	3B
R102	5C	C111	4B
R103	3C	C112	4B
R104	3C	C113	5C
R105	4B	C114	4D
R106	3C	C115	5C
R107	3C	C116	5C
R108	3C	C117	5C
R109	3C	C118	5C
R110	3B	C119	4C
R111	3B	C120	5C
R112	3C	C121	5C
R113	3B	C122	5B
R114	3B	C123	4C
R115	4B	C124	4B
R116	4B	C125	3B
R117	5B	C126	4C
R118	4D	C127	3C
R119	4D	C129	3C
R120	5D	C130	4B
R121	5C	C131	4C
R122	5B	C132	4B
R123	5C	C133	4B
R124	4C	C134	5B
R125	3C	C136	4D
R126	3C	C137	5C
R127	4C	C138	5C
R128	4B	C139	5C
R129	4B	C141	5C
R130	5B	C142	5C
R131	3D	C143	5C
R132	4C	C144	5C
R133	5B	C147	3C
R134	5B	C148	4C
R135	5B	C149	4C
D IN/OUT TERMINAL P.C.B.			
CN105B	8B	R208	7B
JK201	7C	C201	7C
R201	8C	C202	7C
R202	7C	C203	7B
R203	8B	C204	7B
R204	7B	C205	7C
R205	7C	C206	7C
R206	7C	C209	7C
R207	7B		

2

3

4

5

6

D IN/OUT TERMINAL P.C.B.

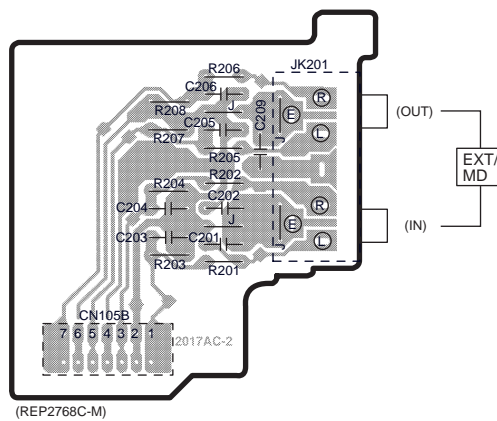

7

8

B FL P.C.B.

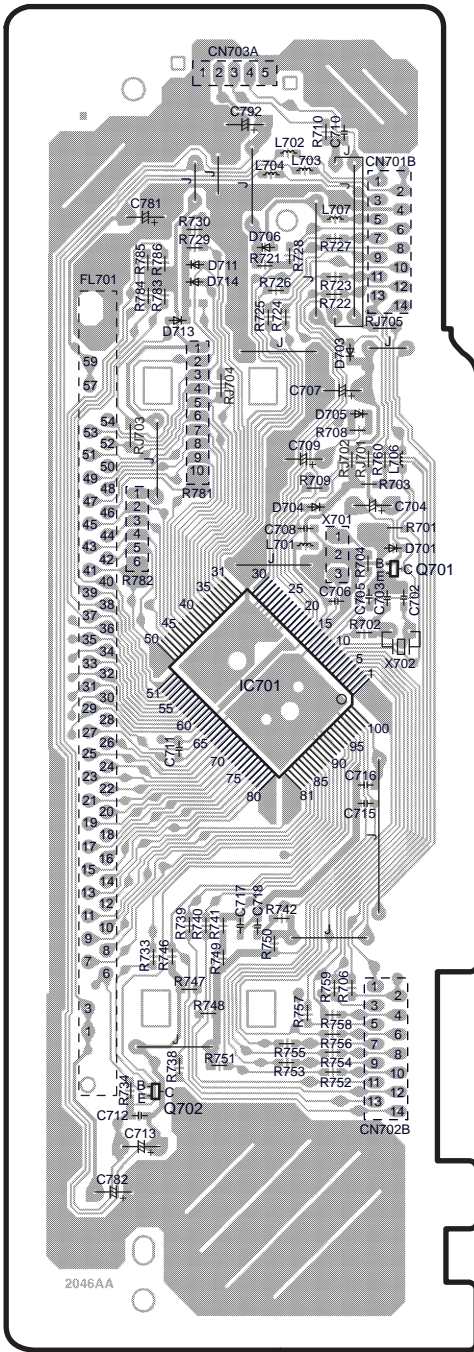

C OPERATION P.C.B.

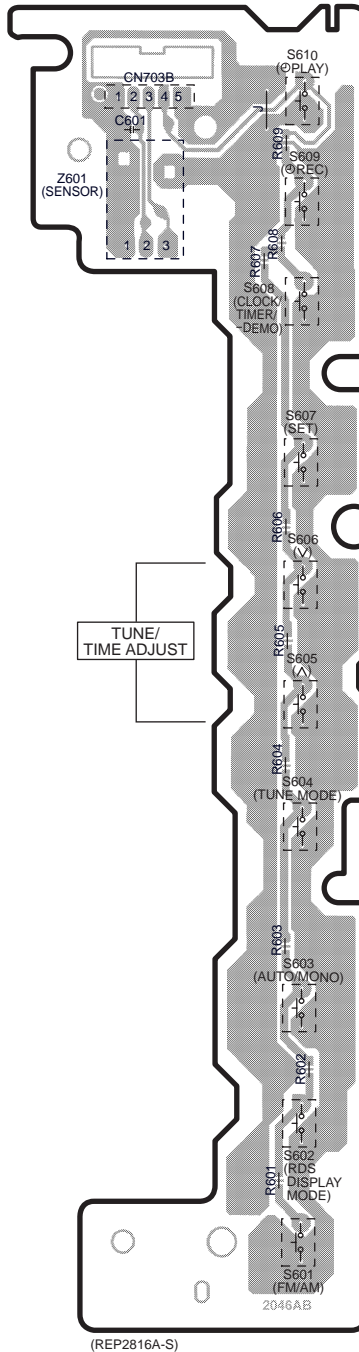

ELECTRICAL PARTS LOCATION

Ref. No.	Lo. No.	Ref. No.	Lo. No.
B FL P.C.B.			
IC701	5B	R742	6B
Q701	4C	R746	6B
Q702	6A	R747	6B
D701	4C	R748	6B
D703	3B	R749	6B
D704	4B	R750	6B
D705	3B	R751	6B
D706	3B	R752	6B
D711	3B	R753	6B
D713	3B	R754	6B
D714	3B	R755	6B
L701	4B	R756	6B
L702	2B	R757	6B
L703	2B	R758	6B
L704	2B	R759	6B
L706	4C	R760	4B
L707	2B	R781	3B
X701	4B	R782	4A
X702	4C	R783	3A
FL701	3A	R784	3A
CN701B	2B	R785	3A
CN702B	6B	R786	3A
CN703A	2B	RJ701	4B
R701	4C	RJ702	4B
R702	4B	RJ703	3A
R703	4B	RJ704	3B
R704	4B	RJ705	3B
R706	6B	C702	4C
R708	3B	C703	4B
R709	4B	C704	4B
R710	2B	C705	4B
R721	3B	C706	4B
R722	3B	C707	3B
R723	3B	C708	4B
R724	3B	C709	4B
R725	3B	C710	2B
R726	3B	C711	5B
R727	3B	C712	6A
R728	3B	C713	7A
R729	3B	C715	5B
R730	2B	C716	5B
R733	6A	C717	6B
R734	6A	C718	6B
R738	6B	C781	2A
R739	6B	C782	7A
R740	6B	C792	2B
R741	6B		
C OPERATION P.C.B.			
Z601	2D	CN703B	2D
S601	7D	R601	7D
S602	7D	R602	6D
S603	6D	R603	6D
S604	5D	R604	5D
S605	5D	R605	4D
S606	4D	R606	4D
S607	4D	R607	3D
S608	3D	R608	3D
S609	2D	R609	2D
S610	2D	C601	2D

F MAIN P.C.B.

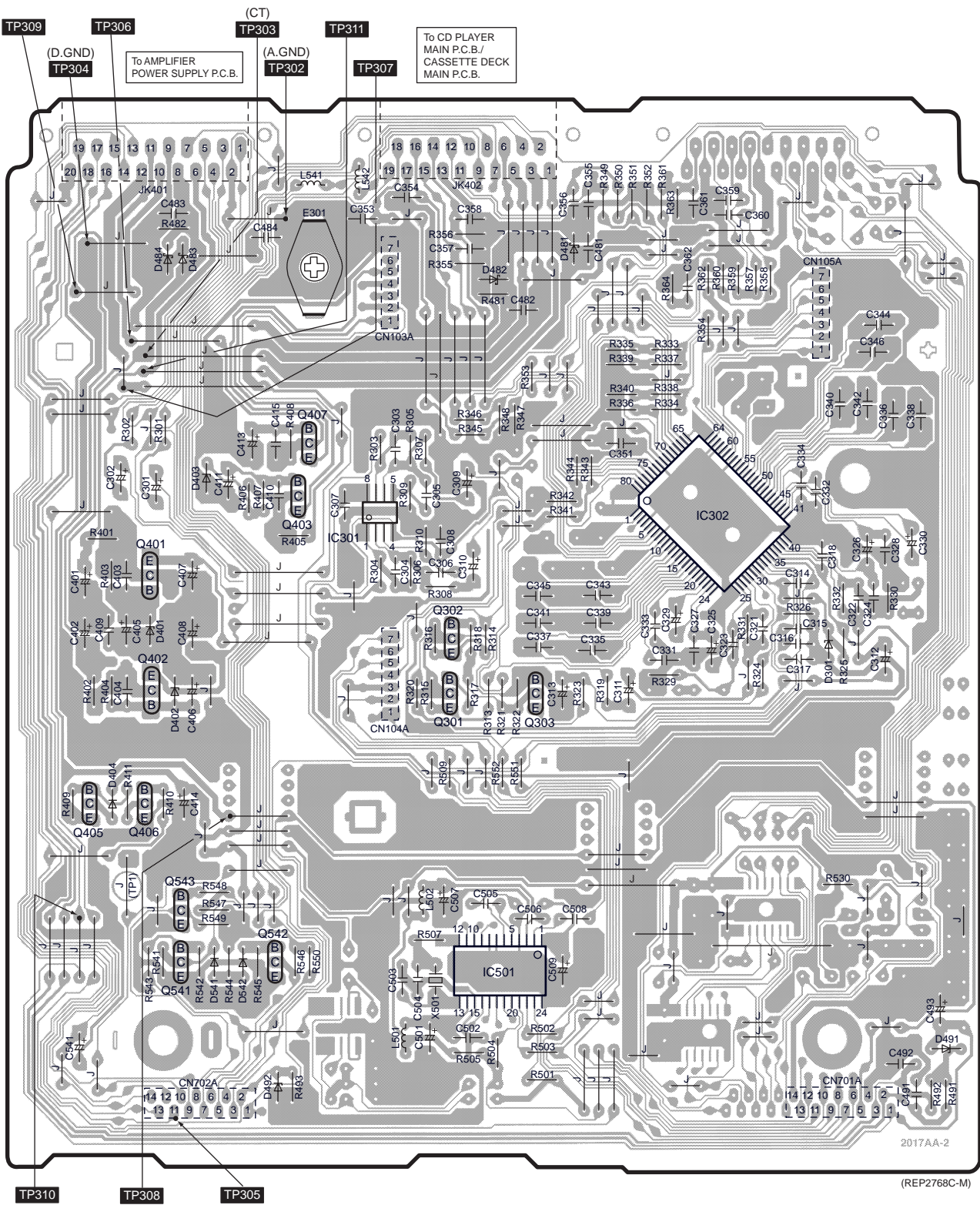

2017AA-2

(REP2768C-M)

E CONNECTOR P.C.B.

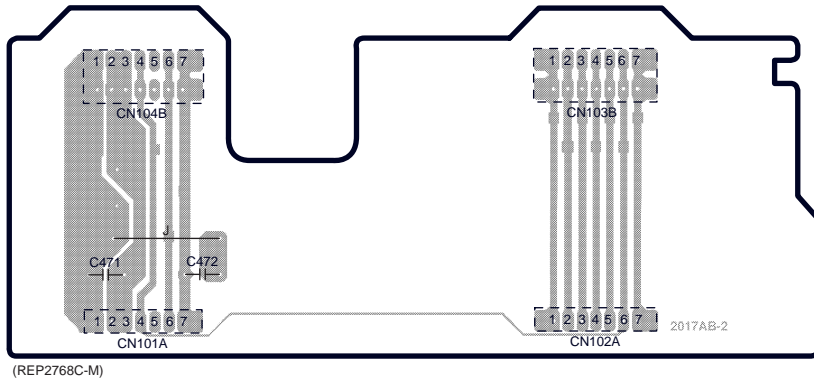

ELECTRICAL PARTS LOCATION

Ref. No.	Lo. No.	Ref. No.	Lo. No.	Ref. No.	Lo. No.	Ref. No.	Lo. No.	Ref. No.	Lo. No.	Ref. No.	Lo. No.
MAIN P.C.B.											
IC301	4C	JK402	2C	R331	5E	R406	4B	C309	4C	C355	2D
IC302	4E	E301	3C	R332	5F	R407	4B	C310	4C	C356	2D
IC501	7D	(TP1)	6A	R333	3E	R408	4B	C311	5D	C357	3C
Q301	5C	TP302	2B	R334	3E	R409	6A	C312	5F	C358	2C
Q302	5C	TP303	3B	R335	3D	R410	6B	C313	5D	C359	2E
Q303	5D	TP304	3A	R336	3D	R411	6A	C314	5E	C360	2E
Q401	4B	TP305	8B	R337	3E	R481	3D	C315	5E	C361	2E
Q402	5B	TP306	3A	R338	3E	R482	2B	C316	5E	C362	3E
Q403	4B	TP307	3A	R339	3D	R491	7F	C317	5E	C401	5A
Q405	6A	TP308	6B	R340	3D	R492	7F	C318	4E	C402	5A
Q406	6B	TP309	3A	R341	4D	R493	7B	C321	5E	C403	4A
Q407	4B	TP310	6A	R342	4D	R501	7D	C322	5F	C404	5A
Q541	7B	TP311	3B	R343	4D	R502	7D	C323	5E	C405	5A
Q542	7B	R301	4B	R344	4D	R503	7D	C324	5F	C406	5B
Q543	6B	R302	4A	R345	4C	R504	7D	C325	5E	C407	4B
D301	5F	R303	4C	R346	4C	R505	7C	C326	4F	C408	5B
D401	5B	R304	4C	R347	4D	R507	7C	C327	5E	C409	5A
D402	5B	R305	4C	R348	4D	R509	6C	C328	4F	C410	4B
D403	4B	R306	4C	R349	2D	R530	6F	C329	5E	C411	4B
D404	6A	R307	4C	R350	2D	R541	7B	C330	4F	C413	4B
D481	3D	R308	5C	R351	2D	R542	7B	C331	5E	C414	6B
D482	3D	R309	4C	R352	2D	R543	7B	C332	4E	C415	4B
D483	3B	R310	4C	R353	3D	R544	7B	C333	5E	C481	3D
D484	3B	R313	5D	R354	3E	R545	7B	C334	4E	C482	3D
D491	7F	R314	5D	R355	3C	R546	7B	C335	5D	C483	2B
D492	7B	R315	5C	R356	2C	R547	6B	C336	4F	C484	2B
D541	7B	R316	5C	R357	3E	R548	6B	C337	5D	C491	7F
D542	7B	R317	5C	R358	3E	R549	6B	C338	4F	C492	7F
L501	7C	R318	5C	R359	3E	R550	7C	C339	5D	C493	7F
L502	6C	R319	5D	R360	3E	R551	6D	C340	3F	C501	7C
L541	2B	R320	5C	R361	2E	R552	6D	C341	5D	C502	7C
L542	2C	R321	5D	R362	3E	C301	4B	C342	3F	C503	7C
X501	7C	R322	5D	R363	2E	C302	4A	C343	5D	C504	7C
CN103A	3C	R323	5D	R364	3E	C303	4C	C344	3F	C505	6D
CN104A	5C	R324	5E	R401	4A	C304	4C	C345	5D	C506	6D
CN105A	3E	R325	5F	R402	5A	C305	4C	C346	3F	C507	6C
CN701A	8F	R326	5E	R403	4A	C306	4C	C351	4D	C508	6D
CN702A	8B	R329	5E	R404	5A	C307	4C	C353	2C	C509	7D
JK401	2B	R330	5F	R405	4B	C308	4C	C354	2C	C541	7A
CONNECTOR P.C.B.											
CN101A	3H	CN102A	3J	CN103B	2J	CN104B	2H	C471	2H	C472	2H