

Service Manual

Tuner

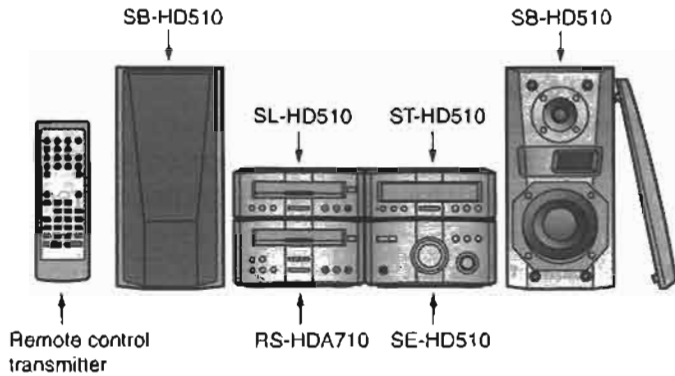

ST-HD510 ST-HD310

Colour

(N)Gold Type

Area

EEurope.

System: SC-HD510

SC-HD310

Because of unique interconnecting cables,when a component requires servise,send or bring in the entire system.

Note: Refer to the service manual for Model No. SE-HD510, SE-HD310 (ORDER NO.AD0001015C2, AD0001018C2) for information on "ACCESSORIES" and "PACKAGING".

Specification

●Pre-amplifier section

Input sensitivity/impedance

EXTERNAL: 300mV/15k Ω

Output level

EXTERNAL: 250mV/1.5k Ω

●FM tuner section

Frequency range: 87.50-108.00MHz(0.05MHz step)

Antenna terminals: 75 Ω (unbalance)

●AM tuner section

Frequency range: 522-1629kHz(9kHz step)

520-1630kHz(10kHz step)

●Timer section

Clock: Quartz-lock type

Function: Play timer:1 time or everyday

Rec.timer:1 time or everyday

Sleep timer:120min., 30min. intervals

●General

Dimensions(WxHxD): 196x76.8x250mm

Weight: 1.0kg

Power Supply AC3.5V.DC \pm 13V/+16V/+10V/+5.6V/-24V

Power Consumption 15W

Notes:

- 1.Design and specifications are subject to change without notice.
- 2.Dimensions and weight are approximate.

●System/SC-HD510:

Tuner:ST-HD510,Compact Disc Player:SL-HD510,Amplifier:SE-HD510,Cassette Deck:RS-HDA710,Speakers:SB-HD510 (Made in MAES)

●System/SC-HD310:

Tuner:ST-HD310,Compact Disc Player:SL-HD310, Amplifier:SE-HD310,Cassette Deck:RS-HD310,Speakers:SB-HD310 (Made in MAES)

Technics[®]

© 2000 Matsushita Electric Industrial Co., Ltd.
All rights reserved. Unauthorized copying and distribution is a violation of law.

⚠ WARNING

This service information is designed for experienced repair technicians only and is not designed for use by the general public. It does not contain warnings or cautions to advise non-technical individuals of potential dangers in attempting to service a product. Products powered by electricity should be serviced or repaired only by experienced professional technicians. Any attempt to service or repair the product or products dealt with in this service information by anyone else could result in serious injury or death.

CONTENTS

	Page	Page
1 Before Repair	2	
2 Operating Instructions	2	
3 About the Self-Diagnostic Mode	3	
4 Power Source ON/OFF and Signal Check	4	
5 Operation Checks and Component Replacement Procedures	5	
5.1. Checking for the tuner P.C.B. and FL P.C.B.	5	
5.2. Checking for the main P.C.B.	5	
6 Wiring Connection Diagram	6	
7 Block Diagram	7	
8 Schematic Diagram Notes	10	
		8.1. Schematic Diagram Notes
		8.2. Type Illustration of IC's Transistors and Diodes
		9 Schematic Diagram
		10 Printed Circuit Board Diagram
		11 Terminal Function of IC's
		11.1. IC302(M62433AFP): DIGITAL SOUND CONTROLLER ..
		11.2. IC701(M30217MAA200): FL DRIVE/SYSTEM CONTROL ..
	
		12 Replacement Parts List
		13 Cabinet Parts Location

1 Before Repair

These equipments (ST-HD510/310), which are the components of the system, are supplied with power from the amplifiers (SE-HD510/310). When repairing these equipments or checking operation of the systems, be sure to connect the

amplifiers with it.

Power supply and operation check in the state of it as a single equipment are impracticable.

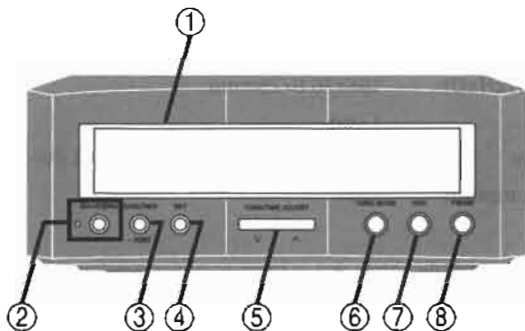
2 Operating Instructions

- ① Display panel
The display also shows information for the cassette deck, CD player, and amplifier.
- ② Play timer/record timer button and Indicator
(⏪ PLAY/⏩ REC)
- ③ Clock/timer, demo button
(CLOCK/TIMER, -DEMO)
- ④ Set button (SET)
- ⑤ Tuning/time adjust buttons
(TUNE/TIME ADJUST ∇, ▲)
- ⑥ Tuning mode button (TUNE MODE)

SC-HD510

- ⑦ RDS button (RDS)
- ⑧ Band select button (FM/AM)

SC-HD310

- ⑦ FM band select button (FM)
- ⑧ AM band select button (AM)

3 About the Self-Diagnostic Mode

This unit is equipped with a self-diagnostic function which, in the event of a malfunction, automatically displays a code

indicating the nature of the malfunctions. Use this self-diagnostic function when servicing the unit.

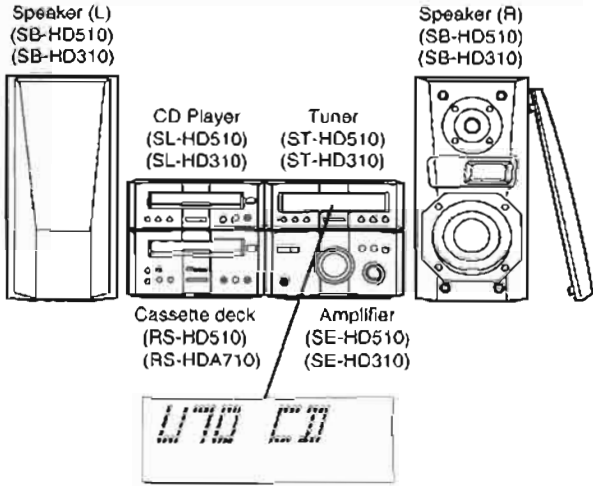
Display method	Display location
<div data-bbox="51 306 500 348" style="border: 1px solid black; padding: 2px; margin-bottom: 10px;">To display the malfunction code</div> <p>U70 CD..... Automatically displays on the tuner when a malfunction occurs.</p> <p>F61..... Automatically displays on the tuner when a malfunction occurs.</p> <div data-bbox="51 493 434 534" style="border: 1px solid black; padding: 2px; margin-top: 10px;">To return the normal display</div> <p>1. For U70 CD:</p> <ul style="list-style-type: none"> • Press any operation button on the tuner. • To re-display the code, switch the power off (POWER STANDBY button), and then switch power back on again. <p>2. For F61 CD:</p> <ul style="list-style-type: none"> • If F61 is displayed, the power will automatically be switched off. • F61 will be displayed for 3 seconds, and then the clock will be displayed. • To re-display the code, switch the power on. F61 will be re-displayed, and then after 3 seconds the clock will be displayed and the power will automatically switch off. 	

Display contents

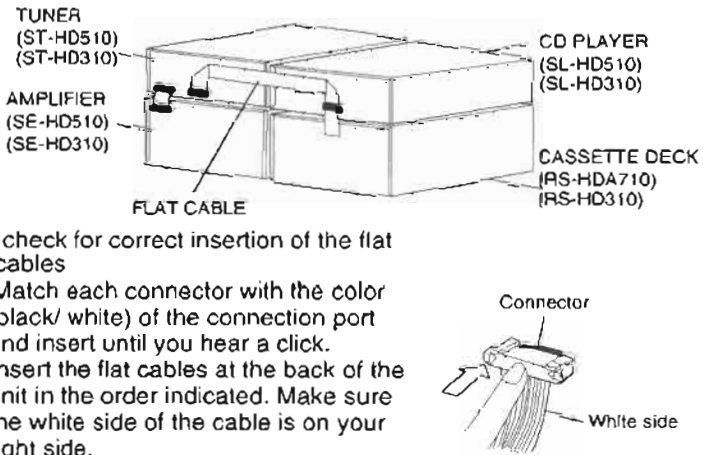
Display code	Problem or condition	Correction procedure
<p>U70 CD (displayed automatically)</p>	<p>A bus-line communications error has occurred as a result of the flat cables being inserted incorrectly, thus preventing the system from operating.</p> <p>1. If U70 is displayed on the tuner, the Cassette deck or CD player cannot be operated by remote control.</p>	 <p>1. To check for correct insertion of the flat cables</p> <ol style="list-style-type: none"> ① Match each connector with the color (black/ white) of the connection port and insert until you hear a click. ② Insert the flat cables at the back of the unit in the order indicated. Make sure the white side of the cable is on your right side. <p>2. Breakage of flat cable (Check and replace as necessary.)</p> <p>3. If the problem is not corrected by items (1.) and (2.) above, this indicates a faulty IC.</p> <p>U70CD [ST-HD510/310: IC701 (M30217MAA200) SL-HD510/310: IC403 (LC66358C4K97)</p> <p>Check these IC's and replace as necessary.</p>
<p>F61</p>	<p>When the power switch is switched on, it automatically switches back off, making it impossible to switch power on.</p>	<p>Faulty amplifier (SE-HD510/310) output IC (IC501 and IC502). (When a DC voltage is applied to the speaker terminals.)</p>

4 Power Source ON/OFF and Signal Check

To operate these units ST-HD510/310 normally, they are necessary for connecting to the units SE-HD510/310.

When operating the unit ST-HD510/310, be sure to connect the units SE-HD510/310 by connection cables.

1. Short the section between TP302 (A.GND) and TP304(D.GND), and as well as the section between TP303(CT) and TP304(D.GND).(As shown in Fig. 1.)
2. Connect with the Amplifier (SE-HD510/310).(As shown in Fig. 1.)

3. Connect the AC mains lead to Amplifier (SE-HD510/310).(As shown in Fig. 1.)
4. Connect the speakers to speaker input terminal.(As shown in Fig. 1.)
5. Turn on the power of the Amplifier (SE-HD510/310).
6. Press INPUT SELECTOR to select the external source (EXT/MD) of the Amplifier (SE-HD510/310).
7. Input a sound signal to external input terminal of Tuner (ST-HD510/310), and confirm to be outputted from the speaker.

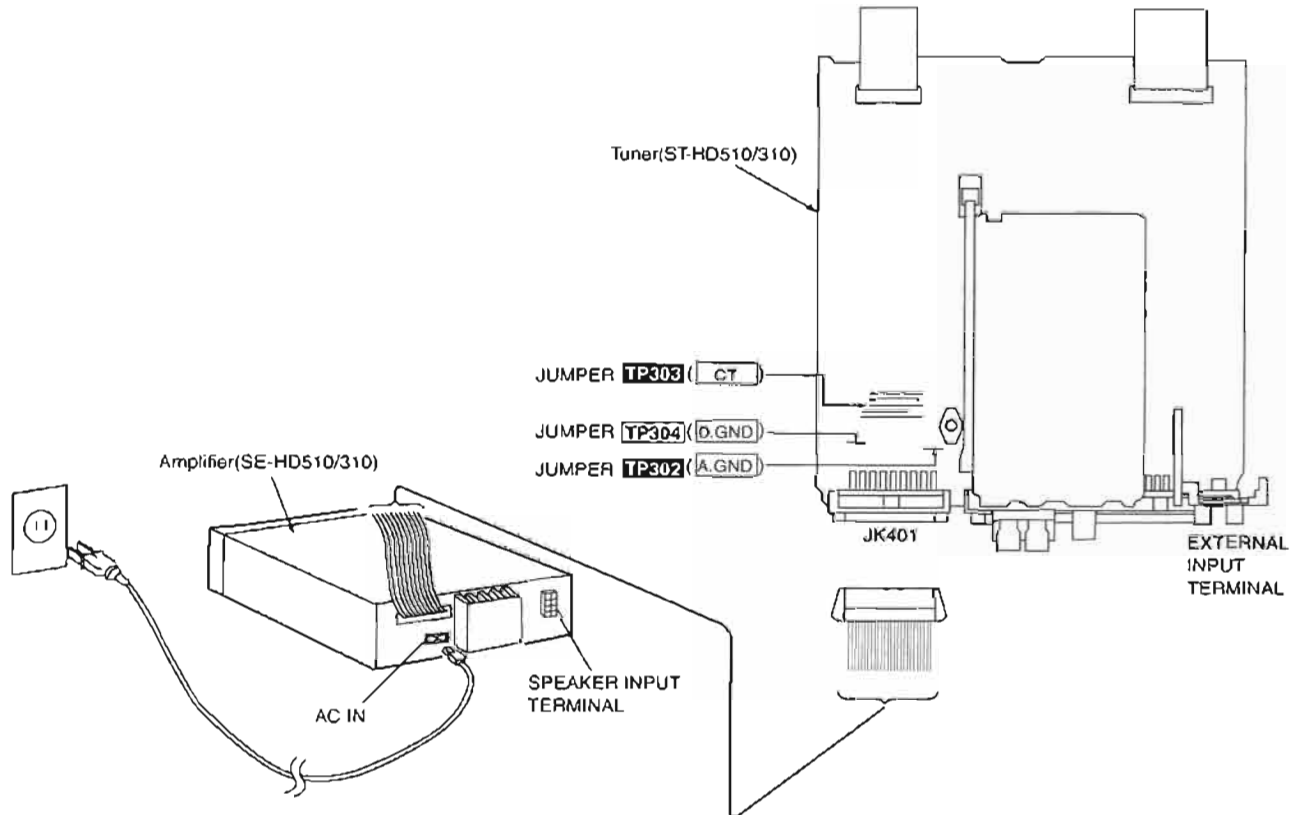
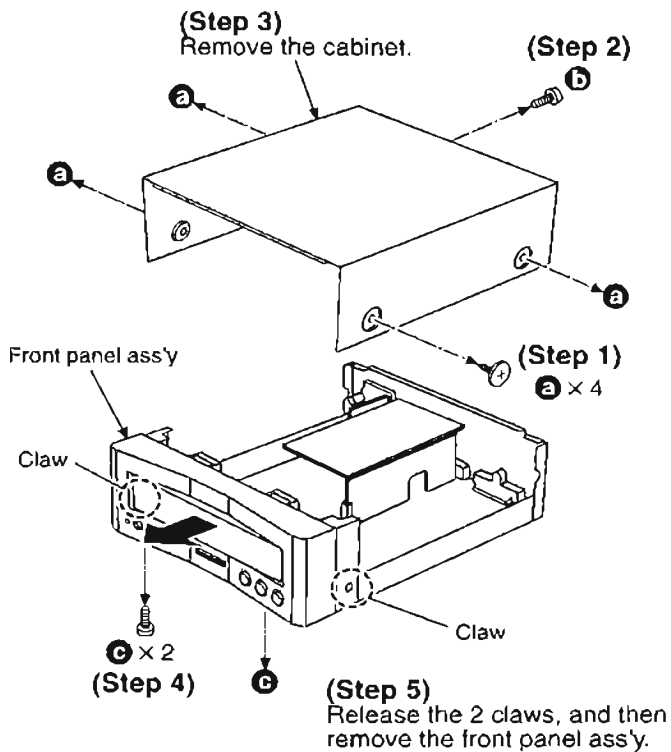

Fig 1

5 Operation Checks and Component Replacement Procedures

- This section describes procedures for checking the operation of the major printed circuit boards and replacing the main components.
- For reassembly after operation checks or replacement, reverse the respective procedures. Special reassembly procedures are described only when required.

5.1. Checking for the tuner P.C.B. and FL P.C.B.



- Check the tuner P.C.B. and FL P.C.B. as shown below.

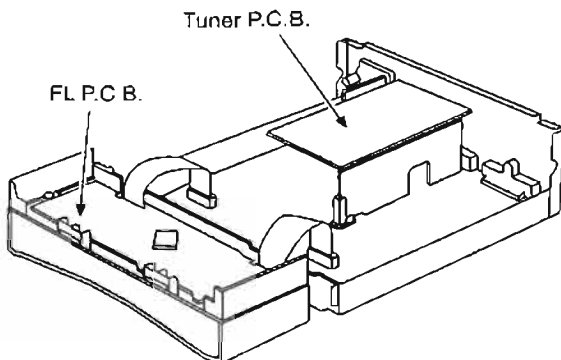

5.2. Checking for the main P.C.B.

- Follow the (Step 1) - (Step 3) of item 5.1.

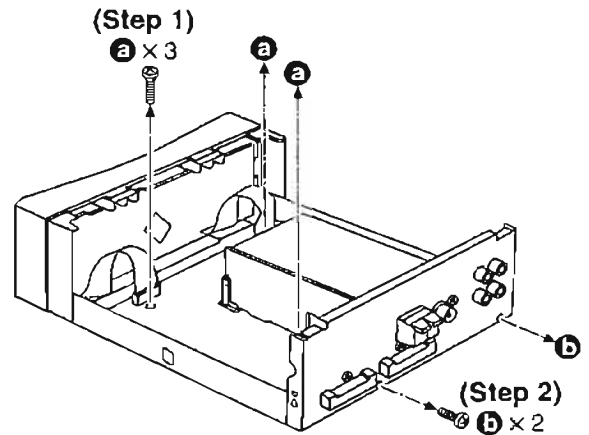

NOTE:
When installing the main P.C.B., make sure that the holes of main P.C.B. are aligned with the ribs of bottom cabinet.

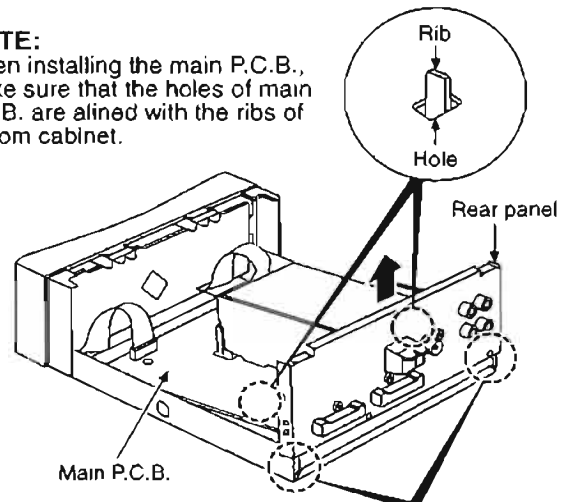

- (Step 3) Release the 2 claws, and then remove the main P.C.B. and rear panel.

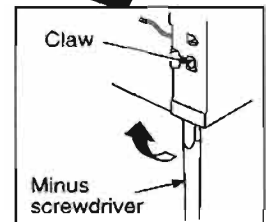

- Check the main P.C.B. as shown below.

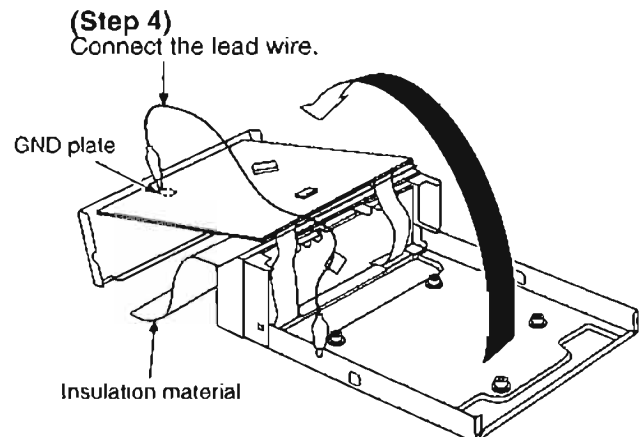

6 Wiring Connection Diagram

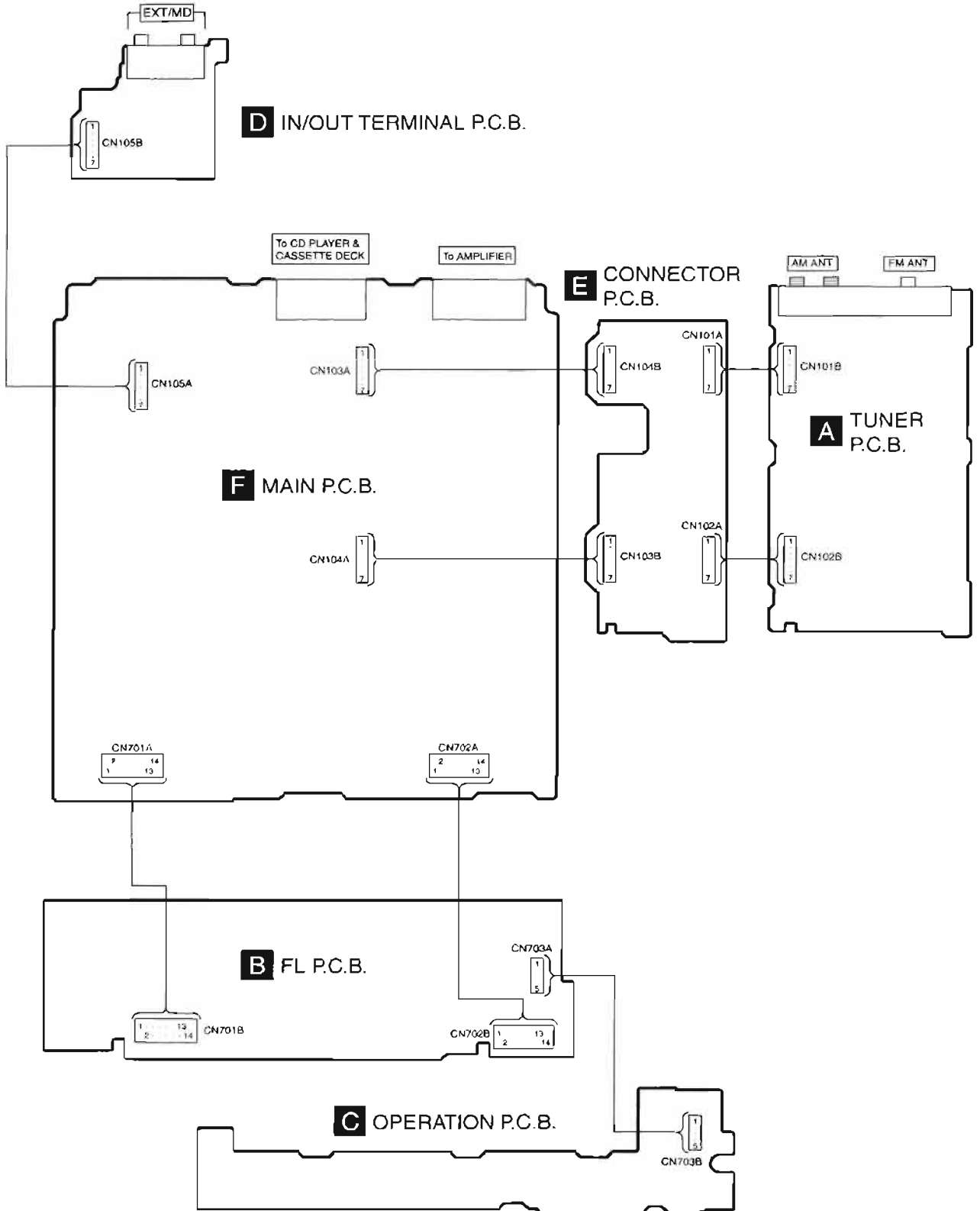

7 Block Diagram

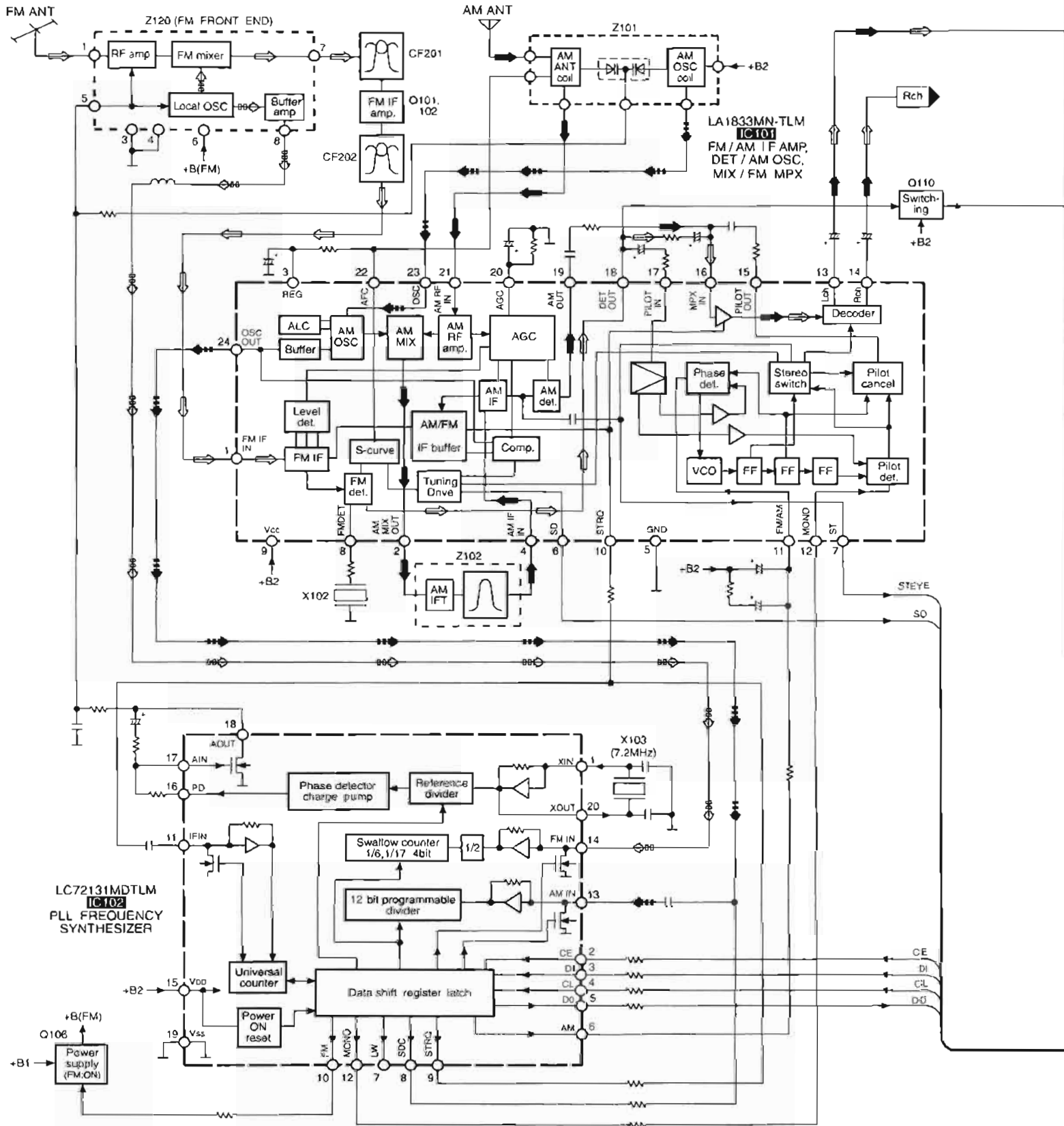

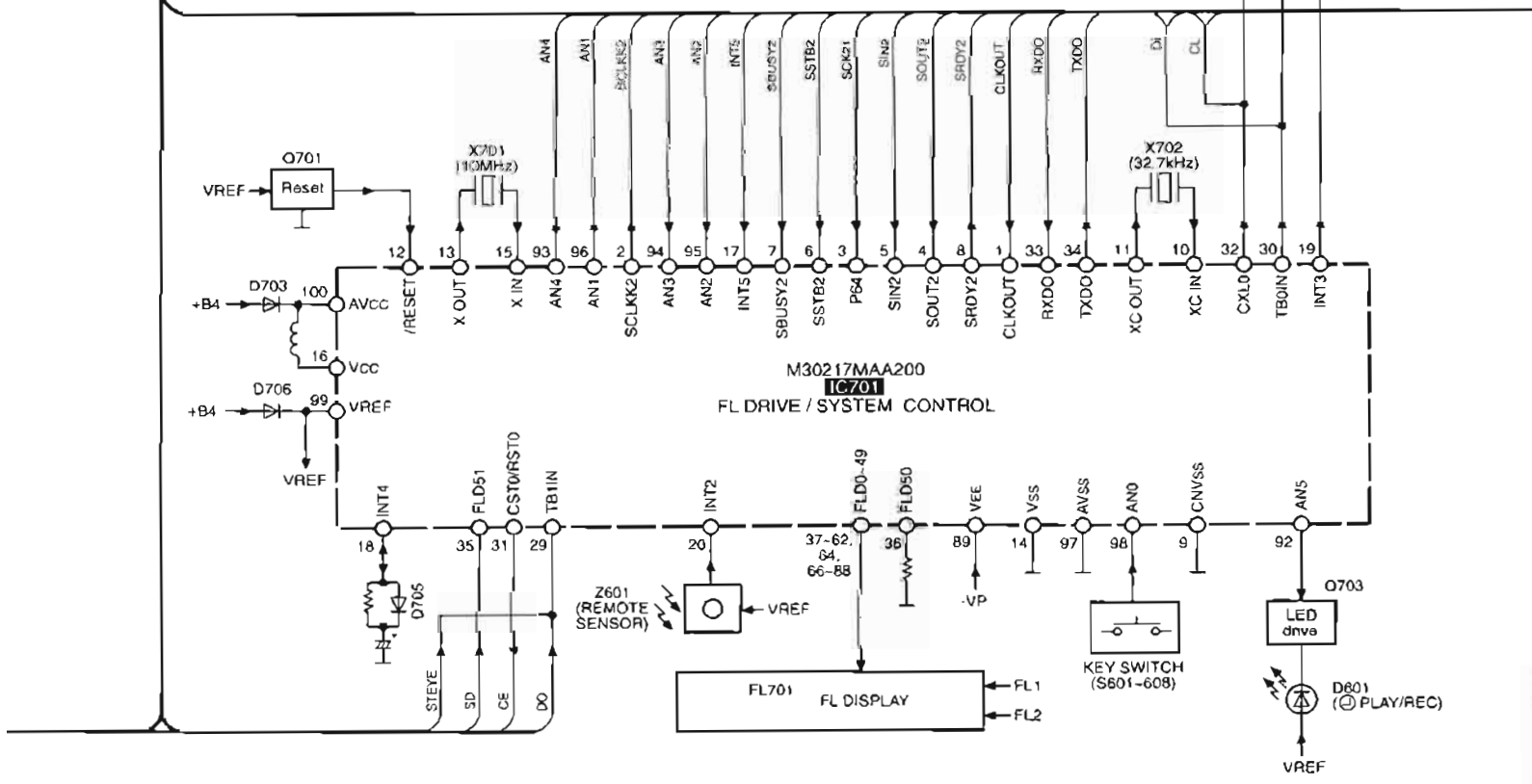
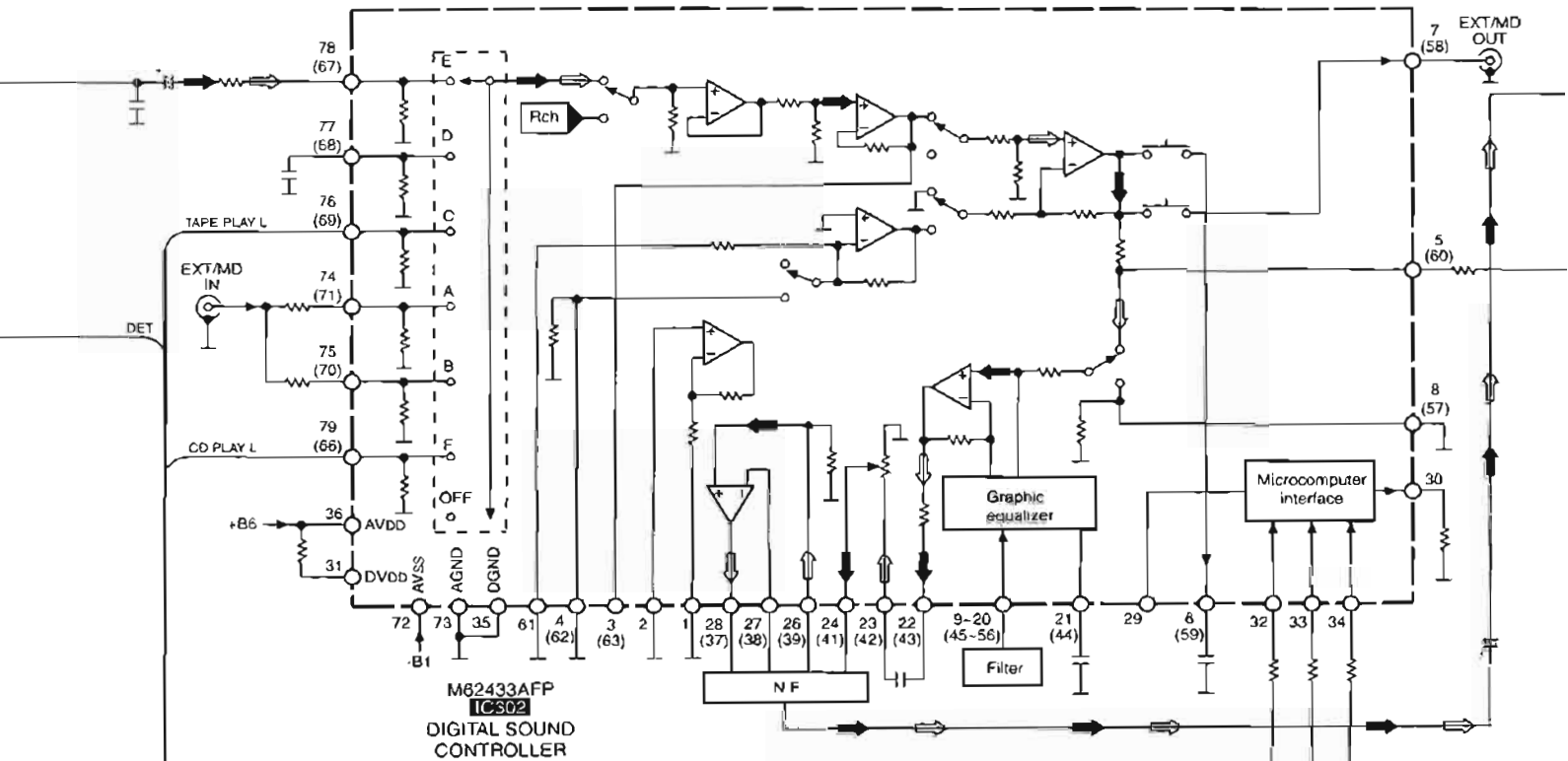

Notes)
 ● Signal line ◁ FM signal ▷ AM signal
 ◻◻◻ FM OSC signal ◻◻◻ AM OSC signal
 ● () indicates pin No. of right channel

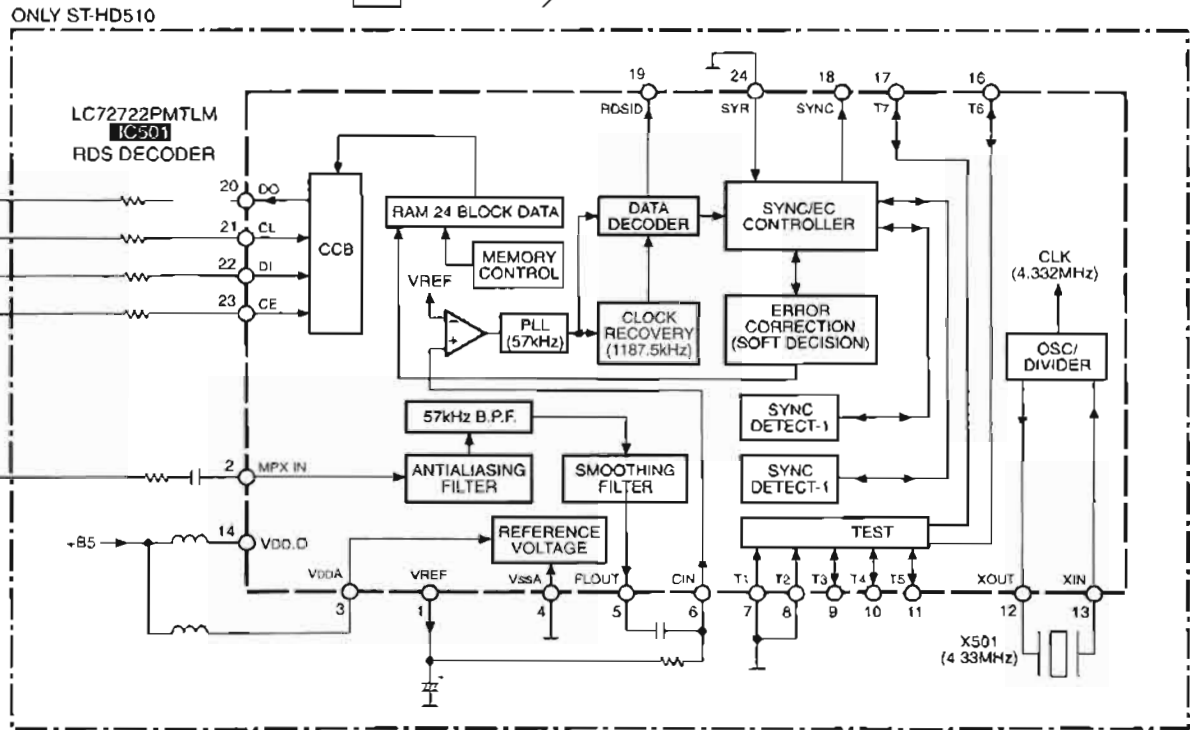
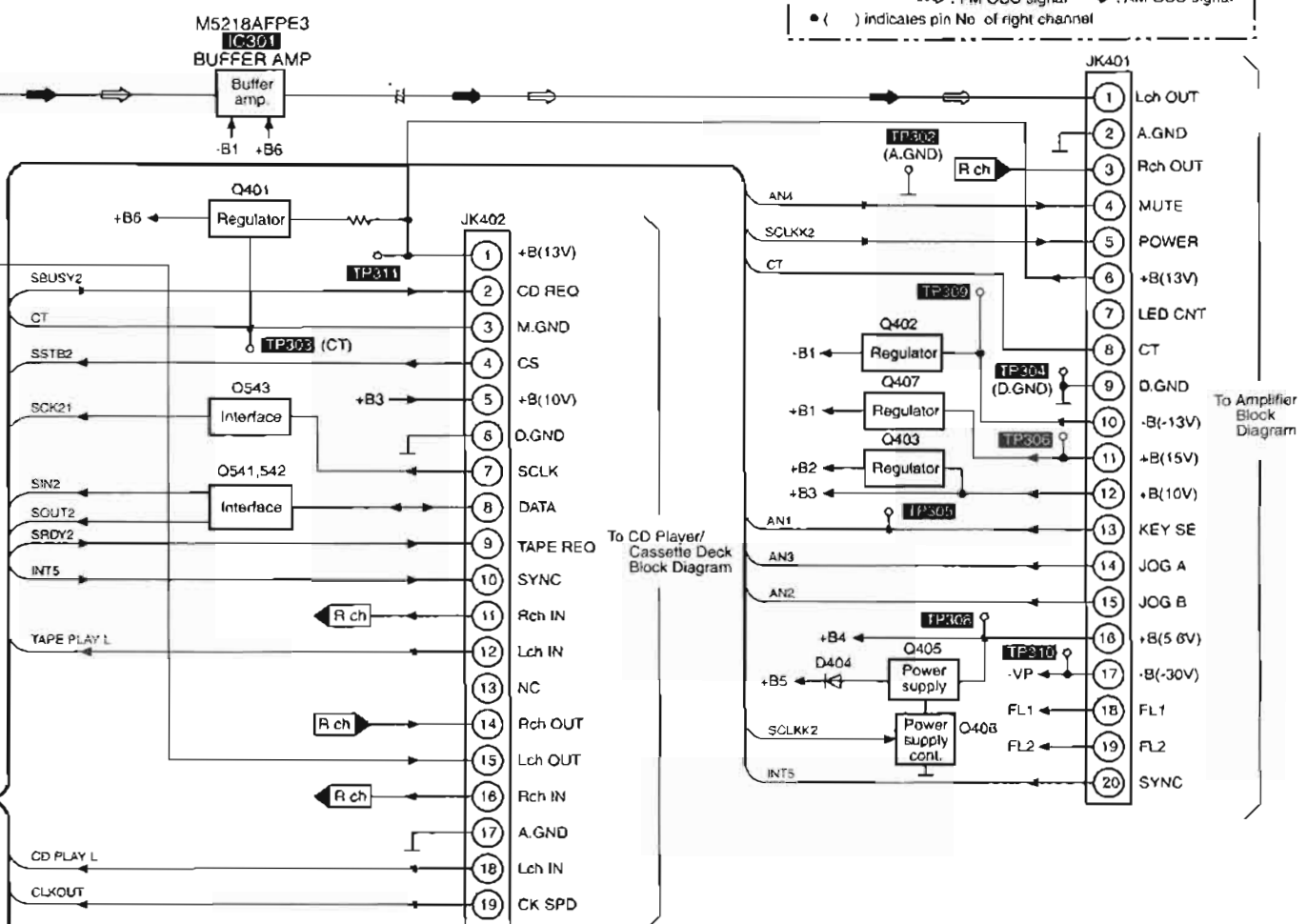

8 Schematic Diagram Notes

8.1. Schematic Diagram Notes

- This schematic diagram may be modified at any time with development of new technology.

Notes:

- S601: For ST-HD510: Band select (FM/AM) switch.
S601: For ST-HD310: AM band select (AM) switch.
- S602: For ST-HD510: RDS (RDS) switch.
S602: For ST-HD310: FM band select (FM) switch.
- S603: Tuning mode (TUNE MODE) switch .
- S604: Tuning/time adjust (\wedge) switch .
- S605: Tuning/time adjust (\vee) switch.
- S606: Set (SET) switch.
- S607: Clock/timer, demo (CLOCK/TIMER,-DEMO) switch.
- S608: Play timer/record timer (\odot PLAY/REC \odot) switch.
- Indicated voltage values are the standard values for the unit measured by the DC electronic circuit tester (high-impedance) with the chassis taken as standard. Therefore, there may exist some errors in the voltage values, depending on the internal impedance of the DC circuit tester.

No mark: FM mode

(): AM mode

Important safety notice:







Components identified by \triangle mark have special characteristics important for safety.

Furthermore, special parts which have purpose of fire-retardant (resistors), high-quality sound (capacitors), low-noise (resistors), etc. are used. When replacing any of components, be sure to use only manufacturer's specified parts shown in the parts list.



Caution!

- IC and LSI are sensitive to static electricity.
- Secondary trouble can be prevented by taking care during repair.
- Cover the parts boxes made of plastics with aluminum foil.
- Ground the soldering iron.
- Put a conductive mat on the work table.
- Do not touch the legs of IC or LSI with the fingers directly.

Voltage and signal line

-  : Positive voltage line
-  : FM signal line
-  : AM signal line
-  : Negative voltage line
-  : FM OSC signal line
-  : AM OSC signal line

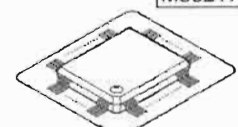
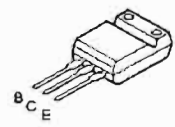
8.2. Type Illustration of IC's Transistors and Diodes

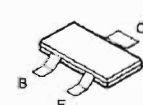
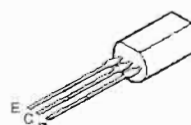
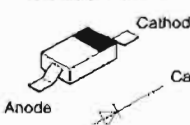
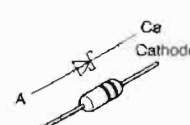
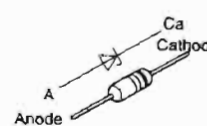
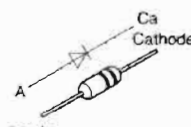
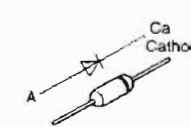
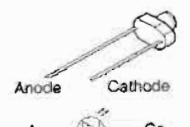
 <table border="1" data-bbox="266 1274 548 1377"> <tr><td>M5218AFPE3</td><td>8PIN</td></tr> <tr><td>LA1833MN-TLM</td><td>24PIN</td></tr> <tr><td>LC72131MDTLM</td><td>20PIN</td></tr> <tr><td>LC72722PMTLM</td><td>24PIN</td></tr> </table>	M5218AFPE3	8PIN	LA1833MN-TLM	24PIN	LC72131MDTLM	20PIN	LC72722PMTLM	24PIN	 <table border="1" data-bbox="736 1295 1003 1357"> <tr><td>M62433AFP</td><td>80PIN</td></tr> <tr><td>M30217MAA200</td><td>100PIN</td></tr> </table>		M62433AFP	80PIN	M30217MAA200	100PIN	 <p>2SB1417PQTA 2SD2137PQTA</p>	 <p>DTB123YSTP DTC114ESTP DTC143XSTP</p>
M5218AFPE3	8PIN															
LA1833MN-TLM	24PIN															
LC72131MDTLM	20PIN															
LC72722PMTLM	24PIN															
M62433AFP	80PIN															
M30217MAA200	100PIN															
 <p>2SC2787LTA 2SC3311ATA 2SC3311ARSTA UN4111TA UN4115TA</p>	 <p>2SD1819ATX UN5214TX</p>	 <p>2SC3940AQSTA</p>	 <p>MA111TX 1SS380TE-17</p>	 <p>MA719TA</p>												
 <p>MA4043MTA MA4051MTA MA4075MTA MA4082LTA</p>	 <p>MA185TA</p>	 <p>MA165TA</p>	 <p>SLR325VCT31</p>													

9 Schematic Diagram

SCHEMATIC DIAGRAM-1

NOTE:
 The number which noted at the connectors on the schematic diagram as
 "SCHEMATIC DIAGRAM-1" or "SCHEMATIC DIAGRAM-2"
 indicates the schematic diagram serial number located on the left corner in the schematic diagram.

A TUNER CIRCUIT

→ : POSITIVE VOLTAGE LINE ⇨ : FM SIGNAL LINE ⇨ : AM SIGNAL LINE
 ⇨ : FM OSC SIGNAL LINE ⇨ : AM OSC SIGNAL LINE

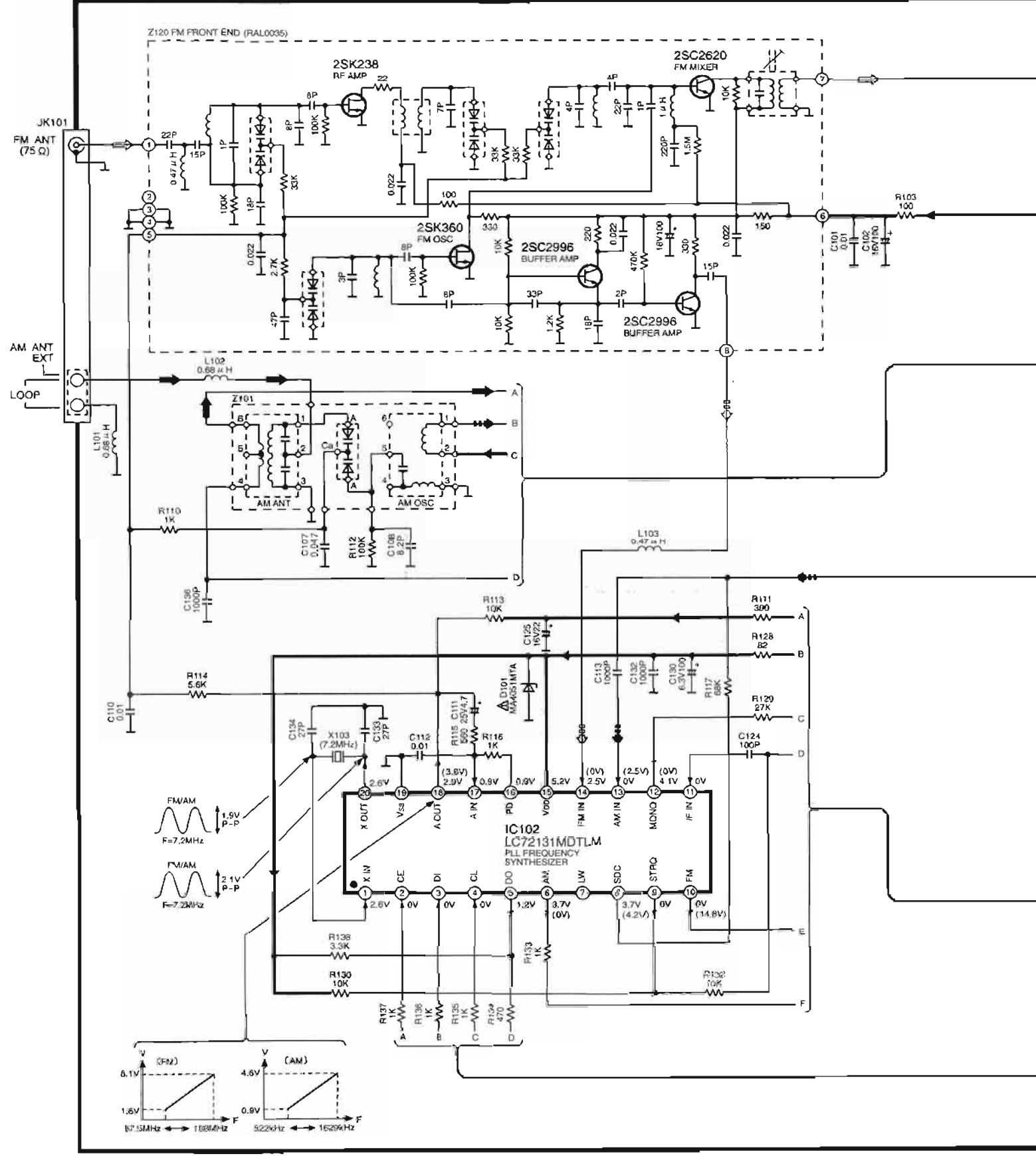

SCHEMATIC DIAGRAM-2

➔ POSITIVE VOLTAGE LINE ⇨ FM SIGNAL LINE ➔ AM SIGNAL LINE ⇨ AM OSC SIGNAL LINE

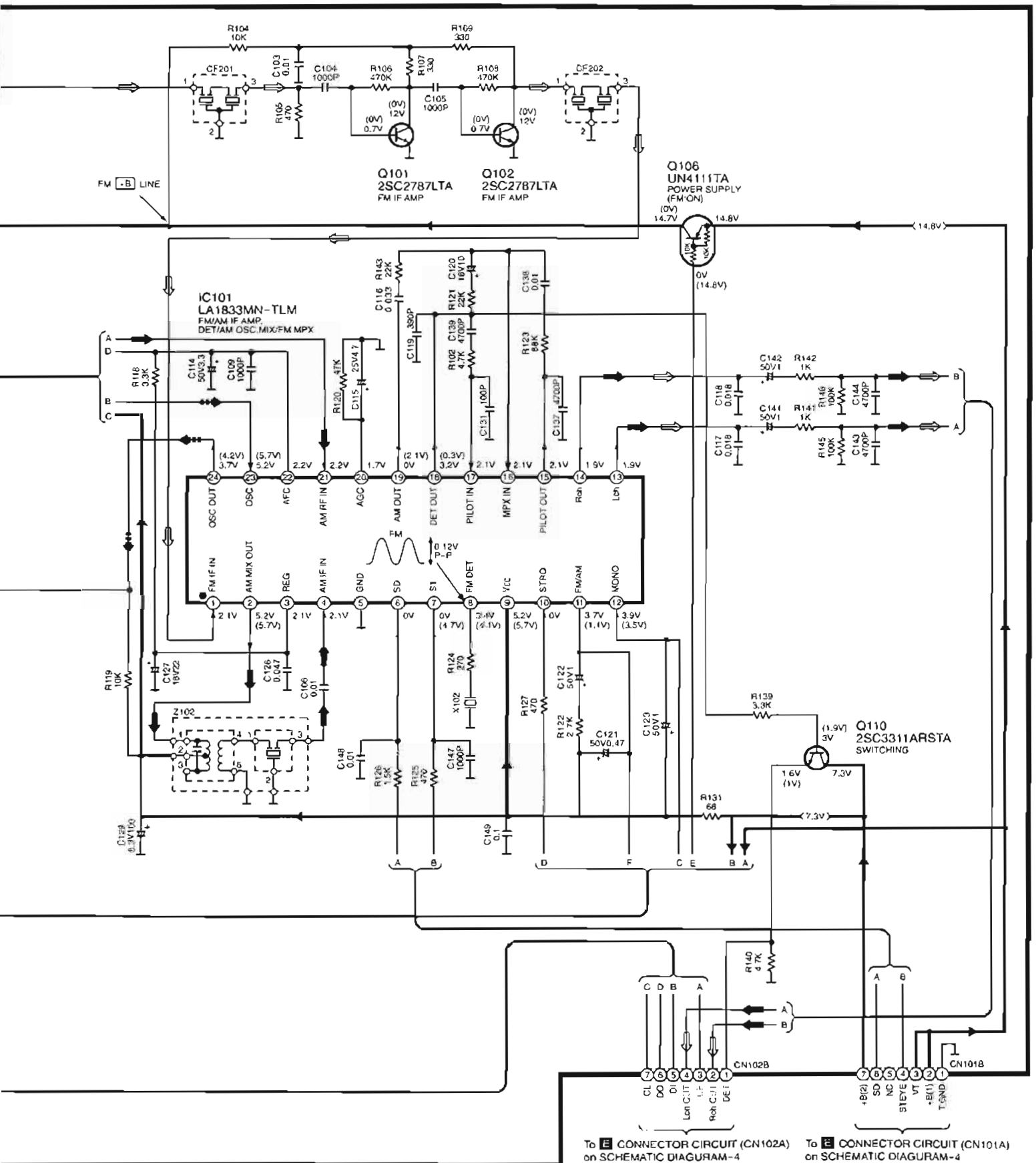

To **ⓔ** CONNECTOR CIRCUIT (CN102A) on SCHEMATIC DIAGRAM-4 To **ⓔ** CONNECTOR CIRCUIT (CN101A) on SCHEMATIC DIAGRAM-4

SCHEMATIC DIAGRAM-3

B FL CIRCUIT

→ POSITIVE VOLTAGE LINE - - - - - :NEGATIVE VOLTAGE LINE

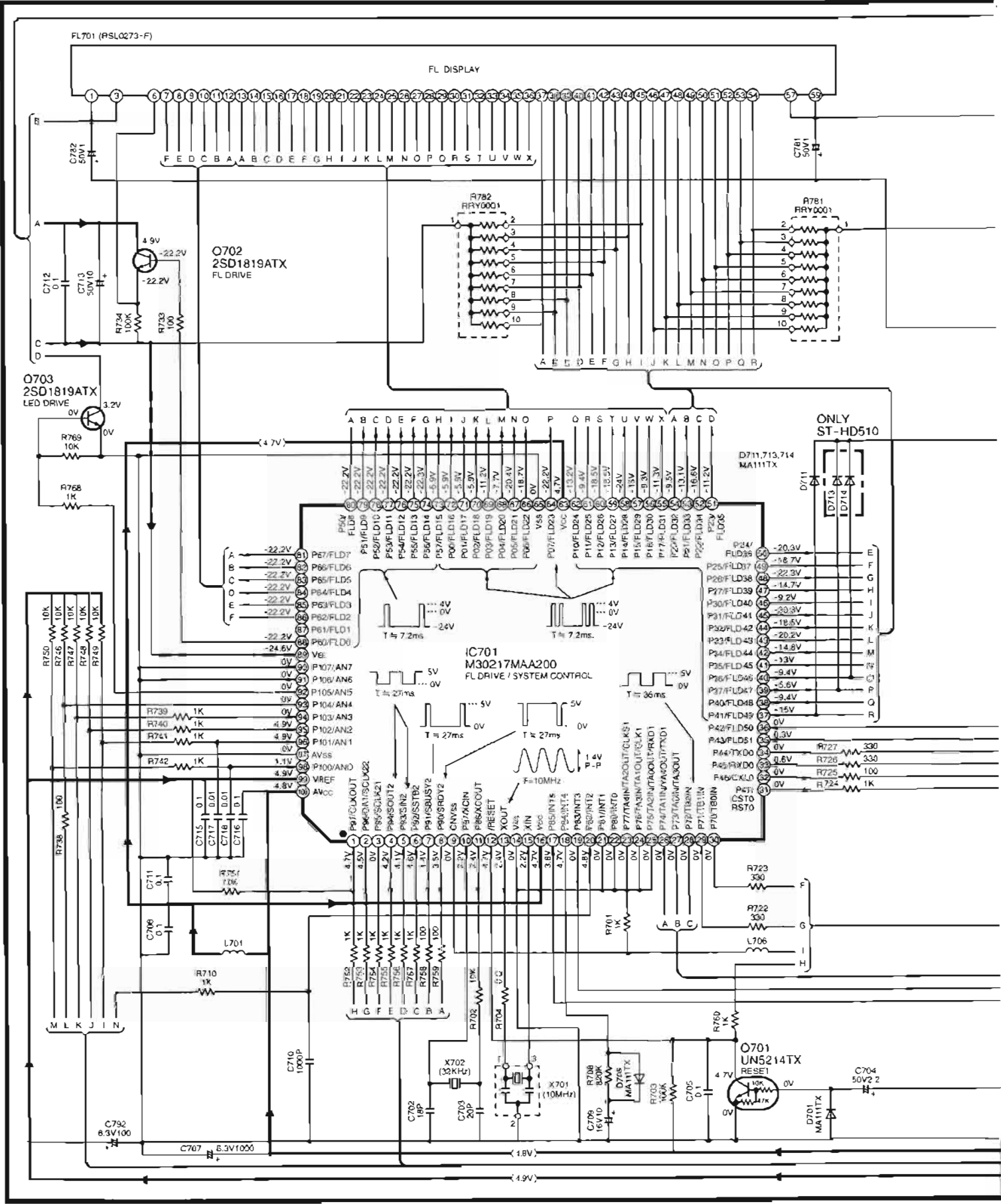

C OPERATION CIRCUIT

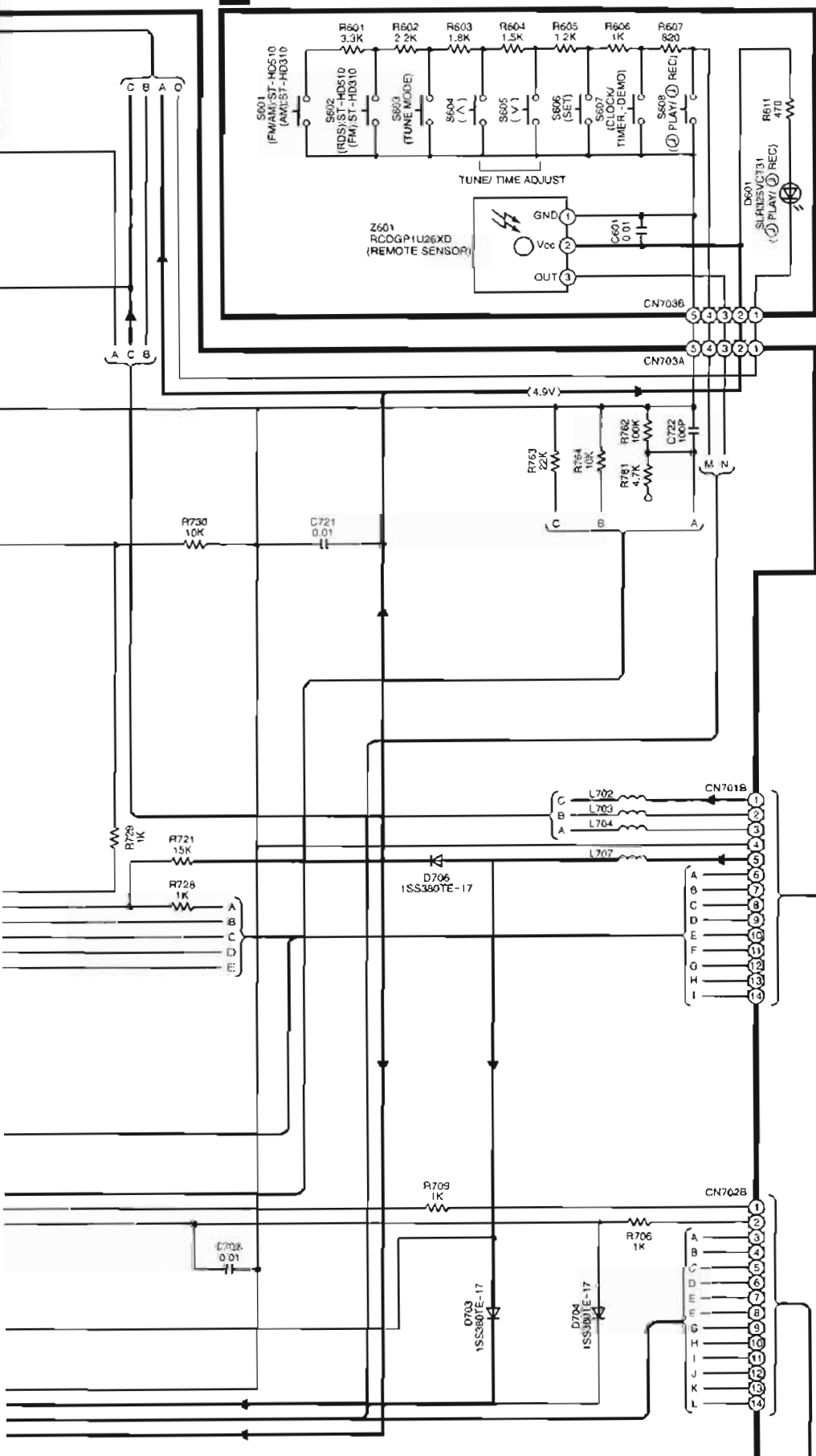

D IN/OUT TERMINAL CIRCUIT

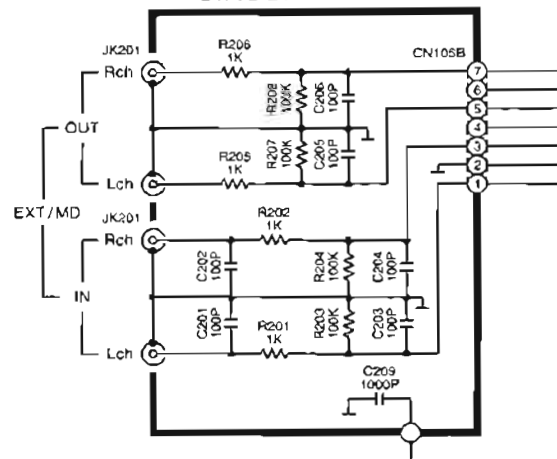

- POSITIVE VOLTAGE LINE
- - - NEGATIVE VOLTAGE LINE
- ⇨ FM SIGNAL LINE
- ⇨ AM SIGNAL LINE

E CONNECTOR CIRCUIT

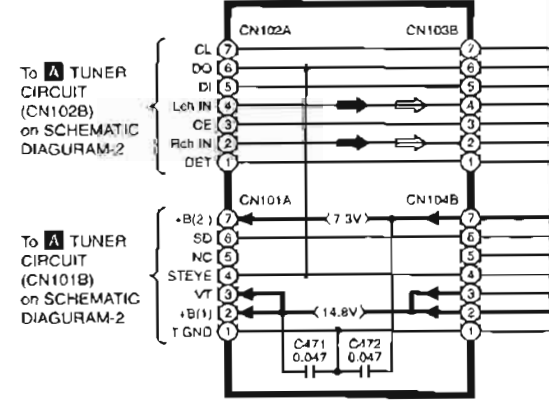

SCHMATIC DIAGRAM-5

F MAIN CIRCUIT

→ POSITIVE VOLTAGE LINE → NEGATIVE VOLTAGE LINE ⇨ FM SIGNAL LINE ⇨ AM SIGNAL LINE

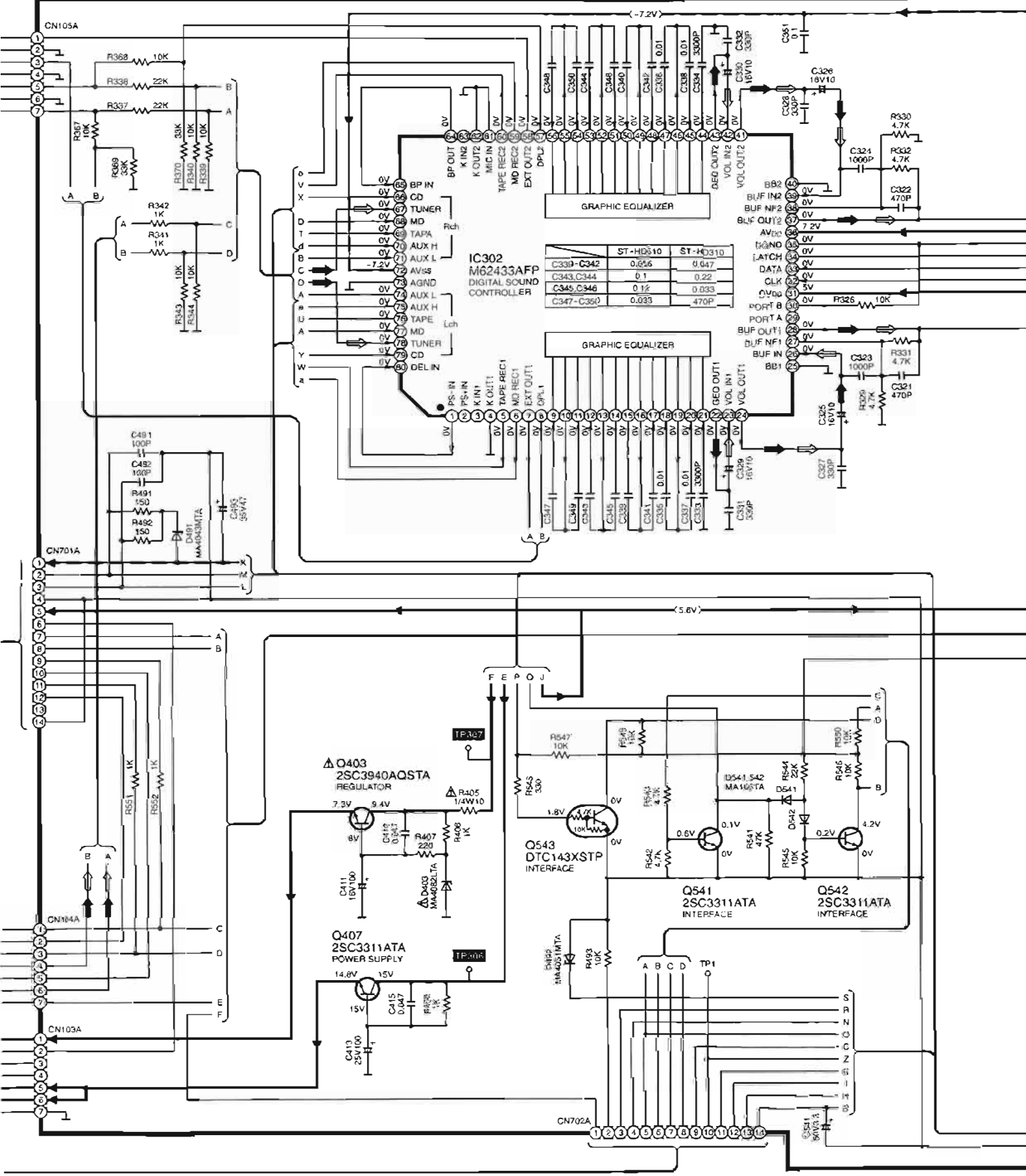

SCHEMATIC DIAGRAM-6

: POSITIVE VOLTAGE LINE
 : NEGATIVE VOLTAGE LINE
 : FM SIGNAL LINE
 : AM SIGNAL LINE

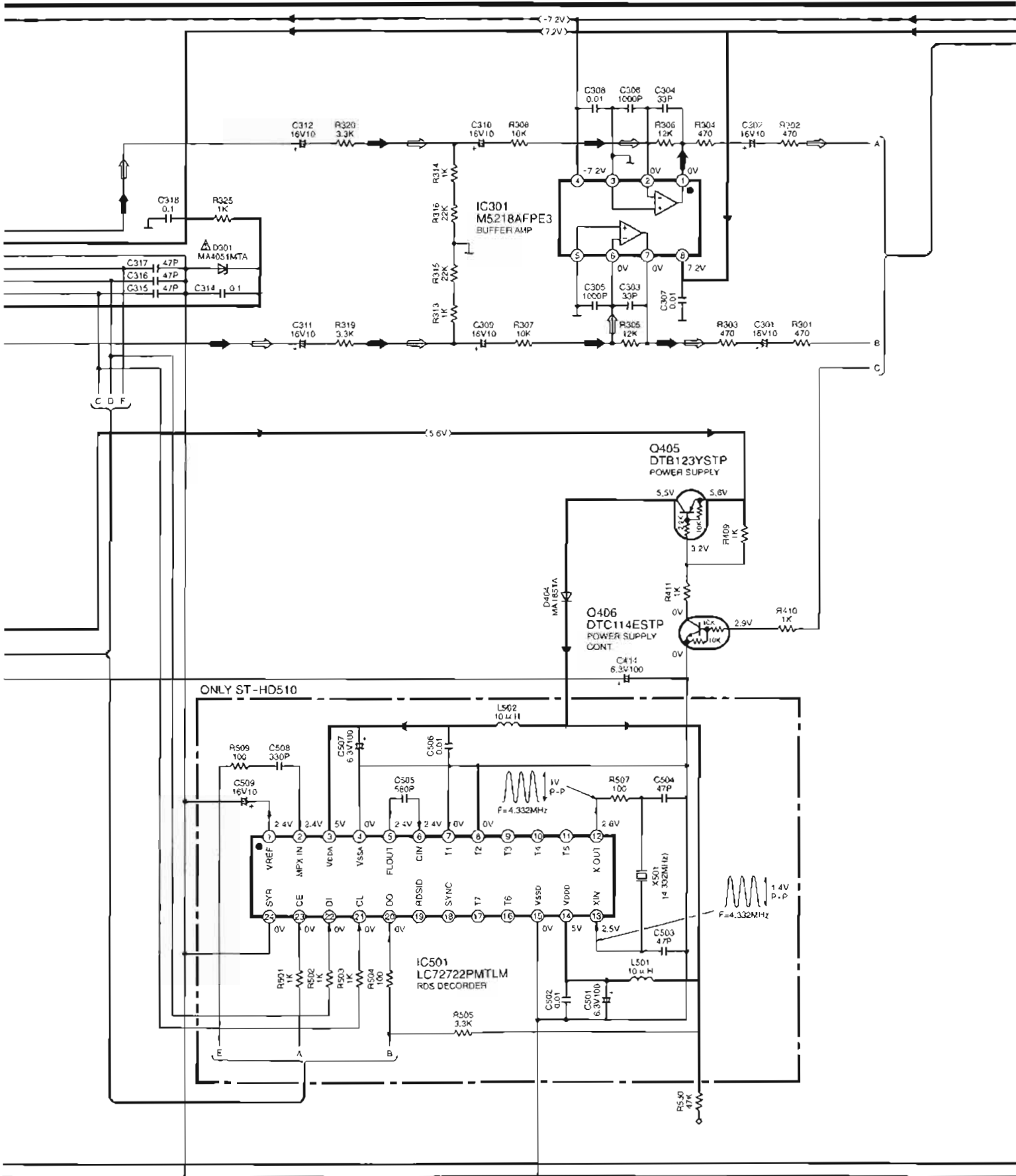

F SCHEMATIC DIAGRAM-7
MAIN CIRCUIT

——— NEGATIVE VOLTAGE LINE ⇨ FM SIGNAL LINE
 - - - POSITIVE VOLTAGE LINE → AM SIGNAL LINE

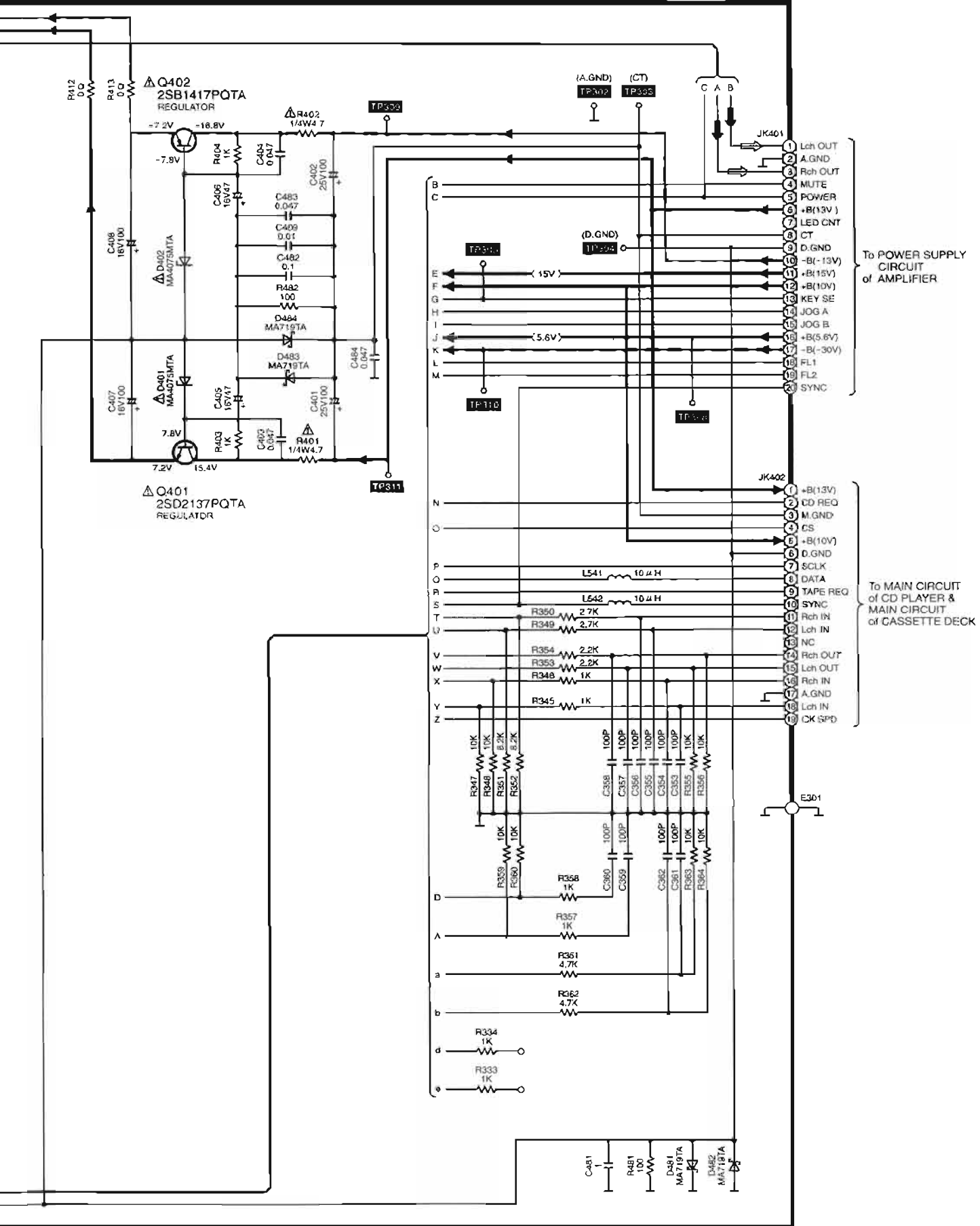

10 Printed Circuit Board Diagram

A B C D E F

1

A TUNER P.C.B.

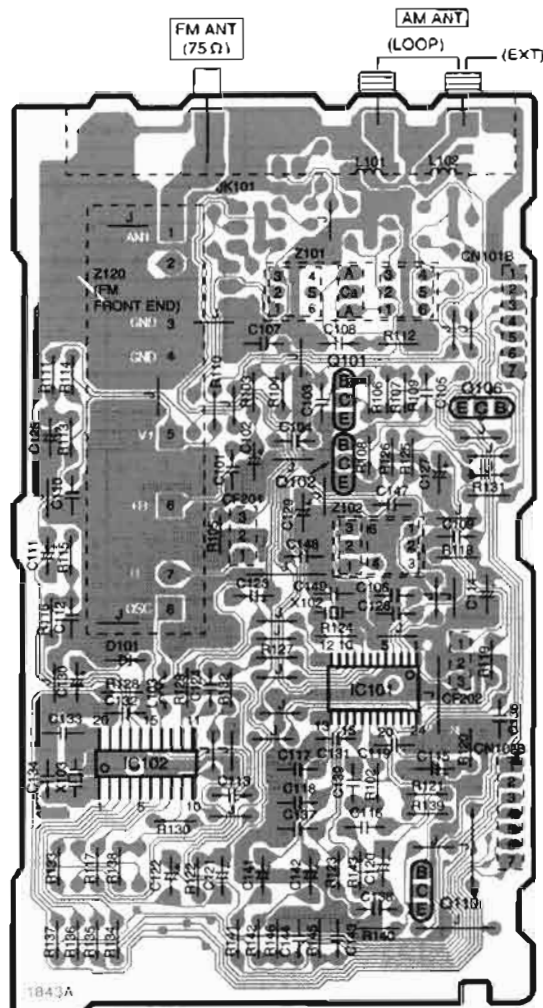

(REP2592C-1)

ELECTRICAL PARTS LOCATION

Ref. No.	Lo. No.	Ref. No.	Lo. No.
A TUNER P.C.B.			
IC101	4C	R136	5B
IC102	5B	R137	5B
Q101	3C	R138	5B
Q102	3C	R139	5C
Q106	3D	R140	5C
Q110	5C	R141	5C
D101	4B	R142	5C
L101	2C	R143	5C
L102	2C	R145	5C
L103	4B	R146	5C
Z101	2C	C101	3C
Z102	4C	C102	3C
Z120	3B	C103	3C
CF201	3C	C104	3C
CF202	4D	C105	3C
X102	4C	C106	4C
X103	5B	C107	3C
CN101B	3D	C108	3C
CN102B	5D	C109	4D
JK101	2C	C110	3B
R102	5C	C111	4B
R103	3C	C112	4B
R104	3C	C113	5C
R105	4B	C114	4D
R106	3C	C115	5C
R107	3C	C116	5C
R108	3C	C117	5C
R109	3C	C118	5C
R110	3B	C119	5C
R111	3B	C120	5C
R112	3C	C121	5B
R113	3B	C122	5B
R114	3B	C123	4C
R115	4B	C124	4B
R116	4B	C125	3B
R117	5B	C126	4C
R118	4D	C127	3C
R119	4D	C129	3C
R120	5D	C130	4B
R121	5C	C131	4C
R122	5B	C132	4B
R123	5C	C133	4B
R124	4C	C134	5B
R125	3C	C136	4D
R126	3C	C137	5C
R127	4C	C138	5C
R128	4B	C139	5C
R129	4B	C141	5C
R130	5B	C142	5C
R131	3D	C143	5C
R132	4C	C144	5C
R133	5B	C147	3C
R134	5B	C148	4C
R135	5B	C149	4C

D IN/OUT TERMINAL P.C.B.

D IN/OUT TERMINAL P.C.B.

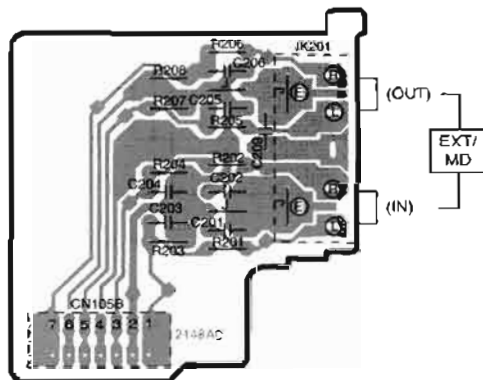

(REP2904B-M ST-HD510)
(REP2904C-M... ST-HD310)

Ref. No.	Lo. No.	Ref. No.	Lo. No.
D IN/OUT TERMINAL P.C.B.			
CN105B	8B	R208	7B
JK201	7C	C201	7C
R201	8C	C202	7C
R202	7C	C203	7B
R203	8B	C204	7B
R204	7B	C205	7C
R205	7C	C206	7C
R206	7C	C209	7C
R207	7B		

8

A B C D E F

1

2

3

4

5

6

7

8

B FL P.C.B.

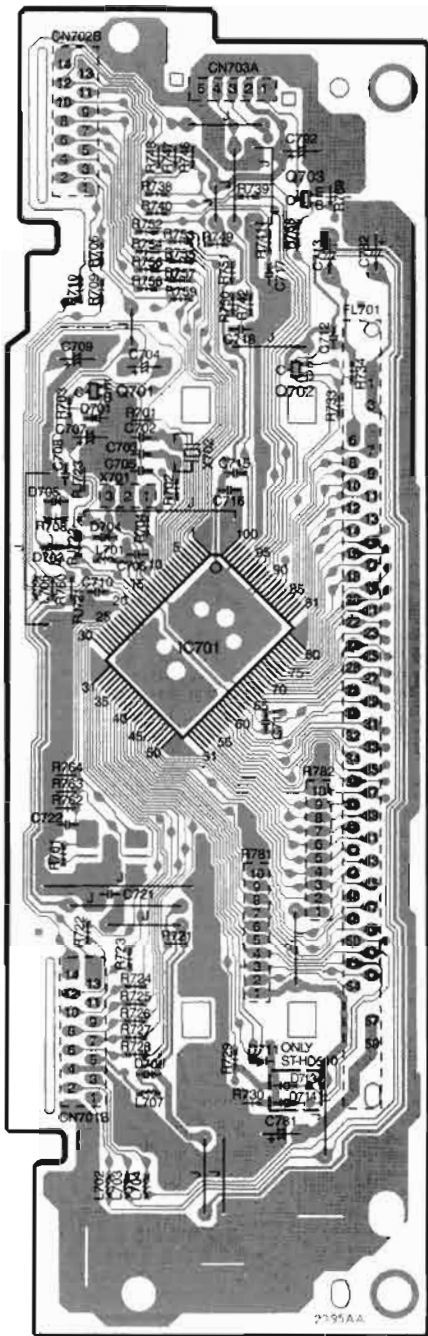

(REP2953A-S ST-HD510)
(REP2953B-S ST-HD310)

C OPERATION P.C.B.

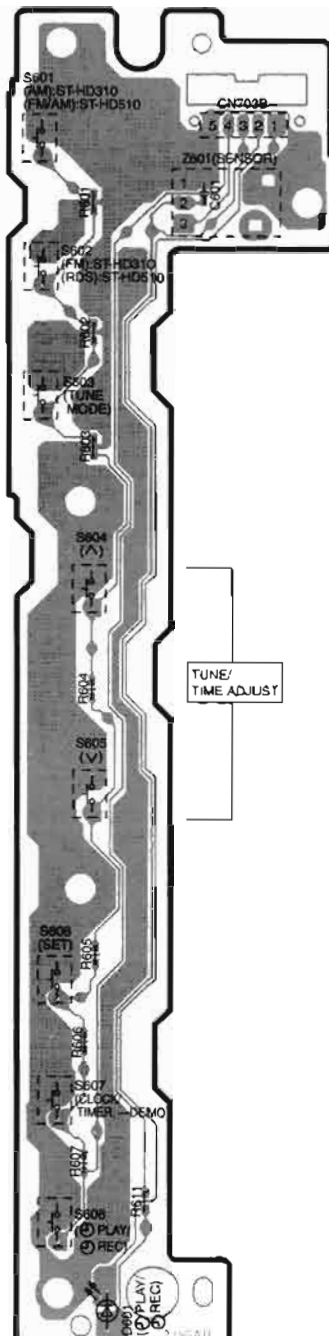

(REP2953A-S ST-HD510)
(REP2953B-S ST-HD310)

■ ELECTRICAL PARTS LOCATION

Ref No	Lo. No	Ref. No.	Lo No
FL P.C.B			
IC701	4B	R742	3B
O701	3A	R746	2B
Q702	3B	R747	2B
O703	2B	R748	2A
O701	3A	R749	3B
D703	4A	R750	3B
D704	4A	R751	3B
D705	4A	R752	2A
D706	6A	R753	3B
D711	8B	R754	3A
D713	8B	R755	3B
D714	8B	R756	3A
L701	4A	R757	3B
L702	7A	R758	3A
L703	7A	R759	3B
L704	7A	R760	4A
L706	4A	R761	5A
L707	6A	R762	5A
X701	4A	R763	5A
X702	4B	R764	5A
FL701	4B	R768	3B
CN701B	6A	R769	2B
CN702B	2A	R781	6B
CN703A	2B	R782	5B
R701	3A	RJ721	4A
R702	4B	RJ722	4A
R703	3A	RJ723	4A
R704	4A	C702	3A
R706	3A	C703	3A
R708	4A	C704	3A
R709	3A	C705	4A
R710	3A	C706	4A
R721	6B	C707	3A
R722	6A	C708	4A
R723	6A	C709	3A
R724	6A	C710	4A
R725	6A	C711	5B
R726	6A	C712	3B
R727	6A	C713	3B
R728	6A	C715	4B
R729	6B	C716	4B
R730	6B	C717	3B
R733	3B	C718	3B
R734	3B	C721	5A
R738	2A	C722	5A
R739	2B	C781	7B
R740	2A	C782	3B
R741	3B	C792	2B
OPERATION P.C.B			
D601	7D	CN703B	2D
Z801	2D	R601	2C
S601	2C	R602	3C
S602	3C	R603	3C
S603	3C	R604	5C
S604	4C	R605	6C
S605	5C	R606	6C
S606	6C	R607	7C
S607	6C	R611	7D
S608	7C	C601	2D

A B C D E F

1
2
3
4
5
6
7
8

F MAIN P.C.B.

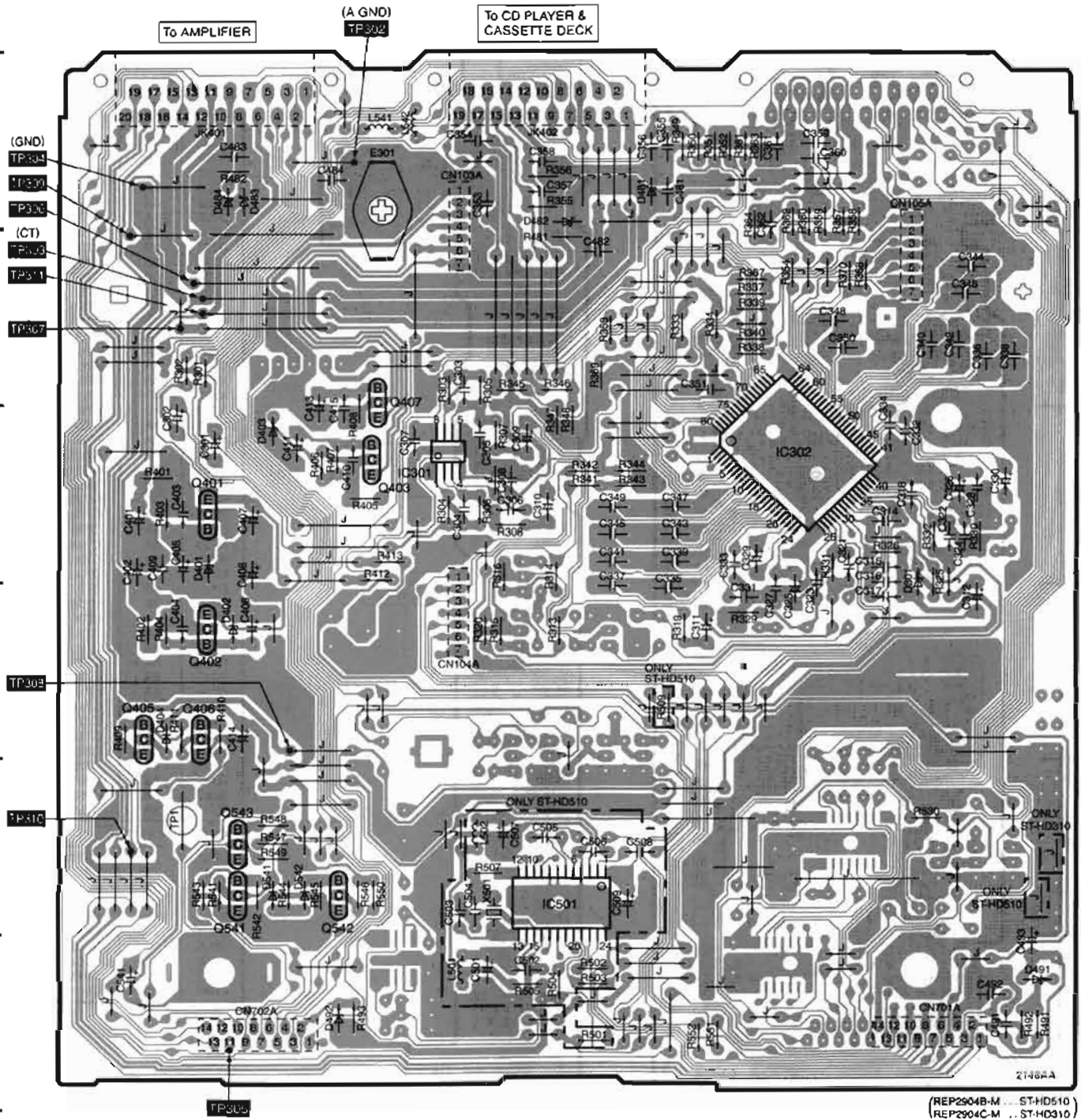

(REP2904B-M ... ST-HD510)
(REP2904C-M ... ST-HD310)

G

H

I

J

K

L

E CONNECTOR P.C.B.

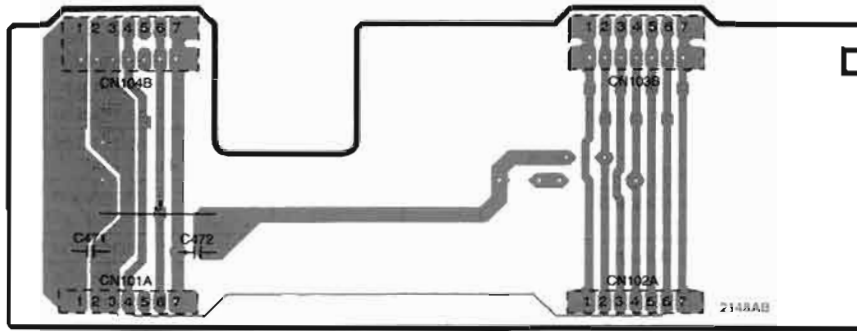

(REP2904B-M...ST-HD510)
(REP2904C-M...ST-HD310)

■ ELECTRICAL PARTS LOCATION

Ref. No.	Lo. No.	Ref. No.	Lo. No.	Ref. No.	Lo. No.	Ref. No.	Lo. No.	Ref. No.	Lo. No.	Ref. No.	Lo. No.
■ MAIN P.C.B.											
IC301	4C	E301	2C	R351	2D	R502	7D	C322	4F	C360	2E
IC302	4E	R301	3B	R352	2E	R503	7D	C323	5E	C361	2E
IC501	8D	R302	3B	R353	3D	R504	7D	C324	4F	C362	2E
Q401	4B	R303	3C	R354	3E	R505	7C	C325	5E	C401	4A
Q402	5B	R304	4C	R355	2D	R507	6C	C326	4F	C402	4A
Q403	4C	R305	3C	R356	2D	R509	5D	C327	5E	C403	4B
Q405	5A	R306	4C	R357	2E	R530	6F	C328	4F	C404	5B
Q406	5B	R307	4C	R358	2E	R541	6B	C329	4E	C405	4B
Q407	3C	R308	4C	R359	2E	R542	6B	C330	4F	C406	5B
Q541	6B	R313	5D	R360	2E	R543	6B	C331	5E	C407	4B
Q542	6B	R314	4D	R361	2E	R544	6B	C332	4F	C408	4B
Q543	6B	R315	5C	R362	2E	R545	6B	C333	4E	C409	4A
D301	5F	R316	4C	R363	2E	R546	6C	C334	4E	C410	4C
D401	4B	R319	5D	R364	2E	R547	6B	C335	5D	C411	4B
D402	5B	R320	5C	R367	3E	R548	6B	C336	3F	C413	4B
D403	4B	R325	5F	R368	3E	R549	6B	C337	5D	C414	5B
D404	5A	R326	4E	R369	3D	R550	6C	C338	3F	C415	4B
D481	2D	R329	5E	R370	3E	R551	7E	C339	4D	C481	2D
D482	2D	R330	4F	R401	4A	R552	7D	C340	3F	C482	3D
D483	2B	R331	4E	R402	5A	C301	4B	C341	4D	C483	2B
D484	2B	R332	4F	R403	4A	C302	4B	C342	3F	C484	2B
D491	7F	R333	3D	R404	5A	C303	3C	C343	4D	C491	7F
D492	7B	R334	3D	R405	4C	C304	4C	C344	3F	C492	7F
D541	6B	R337	3E	R406	4B	C305	4C	C345	4D	C493	7F
D542	6B	R338	3E	R407	4B	C306	4C	C346	3F	C501	7C
L501	7C	R339	3E	R408	4C	C307	4C	C347	4D	C502	7C
L502	6C	R340	3E	R409	5A	C308	4C	C348	3E	C503	6C
L541	2C	R341	4D	R410	5B	C309	4C	C349	4D	C504	6C
L542	2C	R342	4D	R411	5B	C310	4D	C350	3E	C505	6D
X501	6C	R343	4D	R412	4C	C311	5D	C351	3D	C506	6D
CN103A	2C	R344	4D	R413	4C	C312	5F	C353	2C	C507	6C
CN104A	5C	R345	3C	R481	3D	C314	4E	C354	2C	C508	6D
CN105A	3F	R346	3D	R482	2B	C315	4E	C355	2D	C509	6D
CN701A	7F	R347	4D	R491	2D	C316	4E	C356	2D	C541	7A
CN702A	7B	R348	4D	R492	2E	C317	5E	C357	2D		
JK401	2B	R349	2D	R493	3D	C318	4F	C358	2D		
JK402	2D	R350	2D	R501	3E	C321	4E	C359	2E		
■ CONNECTOR P.C.B.											
CN101A	3H	CN103B	2J	C471	2H	C472	2H				
CN102A	3J	CN104B	2H								

11 Terminal Function of IC's

11.1. IC302(M62433AFP): DIGITAL SOUND CONTROLLER

Pin No.	Mark	I/O Division	Function
1	PS-IN	O	R/L output terminal for surround
2	PS+IN	I	Phase shift filter input terminal for surround (Not used, open)
3	KIN1	O	Key control adaptor output terminal (Not used, open)
4	KOUT1	I	Key control adaptor input terminal (Not used, connected to GND)
5	TAPEREC1	O	Rec signal output terminal from surround mix amp. terminal
6	MDREC1	O	Select common output rec signal output terminal
7	EXT OUT1		
8	DPL1	I	Tone signal input terminal
9	F1F1	I	Resonance impedance connect terminal
10	F1O1	O	Resonance buffer amp output terminal
11	FIN1	I	Resonance buffer amp input terminal
12	F2F1	I	Resonance impedance connect terminal
13	F2O1	O	Resonance buffer amp output terminal
14	F2IN1	I	Resonance buffer amp input terminal
15	F3F1	I	Resonance impedance connect terminal
16	F3O1	O	Resonance buffer amp output terminal
17	F3IN1	I	Resonance buffer amp input terminal
18	F4F1	I	Resonance impedance connect terminal
19	F4O1	O	Resonance buffer amp output terminal
20	F4IN1	I	Resonance buffer amp input terminal
21	F5F1	I	Band pass filter connect terminal (Connected to GND through capacitor)
22	GEQOUT1	O	Tone signal output terminal
23	VOLIN1	I	R ladder volume input terminal
24	VOLOUT1	O	R ladder volume output terminal
25	BB1	—	Bass boost capacity connection terminal(Not used, connected to GND)
26	BUFIN	I	Bass boost amp (+) input terminal
27	BUFNF1	I	Bass boost amp (-) input terminal
28	BUFOUT1	O	Bass boost amp output terminal
29	PORTA	O	Port A output terminal (Not used, open)
30	PORTB	O	Port B output terminal (Connected to GND through resistor)
31	DV _{DD}	I	Power supply terminal
32	CLK	I	Clock input terminal for serial data transfer
33	DATA	I	Control data input terminal
34	LATCH	I	Latch signal input terminal
35	DGND	—	GND terminal
36	AV _{DD}	I	Power supply terminal
37	BUFOUT2	O	Bass boost amp output terminal
38	BUFNF2	I	Bass boost amp (-) input terminal
39	BUFIN2	I	Bass boost amp (+) input terminal

Pin No.	Mark	I/O Division	Function		
40	BB2	I	Bass boost capacity connection terminal(Not used, connected to GND)		
41	VOLOUT2	O	R ladder volume output terminal		
42	VOLIN2	I	R ladder volume input terminal		
43	GEQOUT2	O	Tone signal output terminal		
44	F5F2	I	Band pass filter connect terminal (Connected to GND through capacitor)		
45	F4IN2	I	Resonance buffer amp input terminal		
46	F4O2	O	Resonance buffer amp output terminal		
47	F4F2	I	Resonance impedance connect terminal		
48	F3IN2	I	Resonance buffer amp input terminal		
49	F3O2	O	Resonance buffer amp output terminal		
50	F3F2	I	Resonance impedance connect terminal		
51	F2IN2	I	Resonance buffer amp input terminal		
52	F2O2	O	Resonance buffer amp output terminal		
53	F2F2	I	Resonance impedance connect terminal		
54	F1IN2	I	Resonance buffer amp input terminal		
55	F1O2	O	Resonance buffer amp output terminal		
56	F1F2	I	Resonance impedance connect terminal		
57	DPL2	I	Tone signal input terminal		
58	EXT OUT2	O	Select common output rec signal output terminal		
59	MD REC2	O	Rec signal output terminal from surround mix amp. terminal		
60	TAPE REC2	O	Rec signal output terminal from surround mix amp. terminal		
61	MIC IN	I	Mic signal input terminal (Not used, connected to GND)		
62	KOUT2	I	Key control adaptor input terminal (Not used, connected to GND)		
63	KIN2	O	Key control adaptor output terminal (Not used, open)		
64	BPOUT	O	Band pass filter amp output terminal for vocal cancel		
65	BPIN	I	Band pass filter amp input terminal for vocal cancel		
66	CD	I	Input terminal for Rch		
67	TUNER				
68	MD				
69	TAPE				
70	AUXH				
71	AUXL				
72	AVSS			↓	Power supply terminal
73	AGND			—	GND terminal
74	AUXL	I	Input terminal for Lch		
75	AUXH				
76	TAPE				
77	MD				
78	TUNER				
79	CD				
80	DELIN			I	R/L input terminal for surround

11.2. IC701(M30217MAA200): FL DRIVE/SYSTEM CONTROL

Pin No.	Mark	I/O Division	Function
1	P97/CLKOUT	I/O	Communication clock velocity terminal ("H": nomal, "L": CD-TEXT)
2	P96/DA1/SCLK22	O	Clock output terminal for serial data transfer
3	P95/SCLK21	I	CD & Tape communication clock input terminal
4	P94/SOUT2	O	CD & Tape communication data output terminal
5	P93/SIN2	I	CD & Tape communication data input terminal
6	P92/SSTB2	I	CD & Tape communication response input terminal
7	P91/SBUSY2	O	CD communication request output terminal
8	P90/SRDY2	O	Tape communication request output terminal
9	CNV _{SS}	—	GND terminal
10	P87/XCIN	I	Crystal oscillator connection terminal (f=32kHz)
11	P86/XCOUT	O	
12	/RESET	I	Reset input terminal ("L": Micon reset)
13	XOUT	O	Main clock ceramic oscillator output terminal (f=10MHz)
14	VSS	—	GND terminal
15	XIN	I	Main clock ceramic oscillator input terminal (f=10MHz)
16	VCC	I	Power supply terminal
17	P85/INT5	I	Power failure detection input terminal
18	P84/INT4	I/O	CR timer terminal for watch backup
19	P83/INT3	O	Latch output terminal to IC302 (M62433AFP)
20	P82/INT2	I	Remote control data input terminal
21	P81/INT1	I	LED drive signal output terminal("L":OFF,"H":ON) (Connected to GND)
22	P80/INT0	—	Connected to GND
23	P77/TA4IN/TA2OUT/CLKS1	—	
24	P76/TA3IN/TA1OUT/CLK1	—	
25	P75/TA2IN/TA0OUT/RXD1	—	
26	P74/TA1IN/YA4OUT/TXD1	I/O	MD communication data input/output terminal
27	P73/TA0IN/TA3OUT	O	Connected to GND through resistor
28	P72/TB2IN		

Pin No.	Mark	I/O Division	Function
29	P71/TB1IN	I	Tuner reception detect input terminal
30	P70/TB0IN	O	Chip enable signal output terminal to IC501 (LC72722PMTLM)
31	P47/CST0/RST0	O	Chip enable signal output terminal to IC102 (LC72131MDTLM)
32	P46/CXL0	O	Clock output terminal to IC501 (LC72722PMTLM)
33	P45/RXD0	I	Stereo input terminal from IC102 (LC72131MDTLM)
34	P44/TXD0	O	Data output terminal from IC102 (LC72131MDTLM)
35	P43/FLD51	I	Tuner signal detection input terminal from IC101 (LA1833MN-TLM)
36	P42/FLD50	I	Chip select input terminal
37	P41/FLD49	I/O	FL segment control input/output terminal
~	~		
40	P36/FLD46		
41	P35/FLD45	O	FL segment control output terminal
~	~		
54	P20/FLD32		
55	P17/FLD31		
~	~		
62	P10/FLD24		
63	VCC	I	Power supply terminal
64	P70/FLD23	O	FL segment control output terminal
65	VSS	—	GND terminal
66	P06/FLD22	O	FL segment control output terminal
~	~		
72	P00/FLD16		
73	P57/FLD15	O	FL segment control output terminal
74	P56/FLD14	O	FL grid control output terminal
~	~		
80	P50/FLD8		
81	P67/FLD7	O	FL grid control output terminal
~	~		
86	P62/FLD2		
87	P61/FLD1	O	FL grid control output terminal (Not used, open)
88	P60/FLD0	O	FL grid control output terminal
89	VEE	I	Power supply terminal
90	P107/AN7	I	Key switch connect input terminal
91	P106/AN6		
92	P105/AN5	O	Key switch connect output terminal
93	P104/AN4	O	Muting output terminal ("H": OFF, "L": ON)
94	P103/AN3	I	Key switch connect terminal from SE-HD510/310
~	~		
96	P101/AN1		
97	AVSS	—	Connected to GND
98	P100/AN0	I	Key switch input terminal
99	VREF	I	Power supply terminal
100	AVCC		

12 Replacement Parts List

Note:

*Important safety notice:

Components identified by Δ mark have special characteristics important for safety.

Furthermore, special parts which have purposes of fire-retardant (resistors), high-quality sound (capacitors), low-noise (resistors), etc. are used.

When replacing any of components, be sure to use only manufacturer's specified parts shown in the parts list.

*The markings <RTL> indicate that the Retention Time is limited for these items. After the discontinuation of these assemblies in production, the items will continue to be available for a specific period of time. The retention period of availability is dependant on the type of assembly, and in accordance with the laws governing part and product retention. After the end of this period, the assembly will no longer be available.

*Capacity values are in microfarads (μ F) unless specified otherwise, P=Pico-farads (pF) F=Farads (F)

*Resistance values are in ohms, unless specified otherwise, 1K=1,000 (OHM), 1M=1,000k (OHM)

Ref. No.	Part No.	Part Name & Description	Pcs	Remarks
1	RHD30007-S	SCREW	4	
2	RKM0413-N	CABINET	1	
3	XTB3+8JFZ	SCREW	1	
4	REZ1317	FPC (14P)	2	
5	RKA0114-K	FOOT	4	
5-1	RKA0083-K	CUSHION	4	
6	RMN0195	FL HOLD PIECE	2	
7	RGG0174-N	FRONT PANEL	1	HD310
7	RGG0174A-N	FRONT PANEL	1	HD510
8	RGL0481-Q	TIMER INDICATOR	1	
9	RGP0775-N	SUB PANEL	1	
10	RGU1840-N	BUTTON, BAND	1	HD310
10	RGU1857-N	BUTTON, BAND	1	HD510
11	RGU1843-N	BUTTON, UP/DOWN	1	
12	RKW0600-N	WINDOW	1	
13	XTBS26+8J	SCREW	11	
14	XTBS3+8JFZ1	SCREW	9	
15	XTB3+12JFZ	SCREW	3	
16	XTB3+5JFZ	SCREW	4	
C101	ECBT1C103NS5	16V 0.010	1	
C102	ECEA1CKS101	16V 1000	1	
C103	ECBT1C103NS5	16V 0.010	1	
C104,05	ECBT1H102KB5	50V 1000P	2	
C106	ECBT1C103NS5	16V 0.010	1	
C107	ECBT1H473ZF5	50V 0.047U	1	
C108	ECBT1H8R2KC5	50V 8.2P	1	
C109	ECBT1H102KB5	50V 1000P	1	
C110	ECBT1C103NS5	16V 0.010	1	
C111	ECEA1EKS4R7	25V 4.7U	1	
C112	ECBT1C103NS5	16V 0.010	1	
C113	ECBT1H102KB5	50V 1000P	1	
C114	RCE1HKA3R3BG	50V 3.30	1	
C115	ECEA1EKS4R7	25V 4.7U	1	
C116	ECFR1C333KR	16V 0.033U	1	
C117,18	ECFR1C183KR	16V 0.018U	2	
C119	ECQP1391JZ	100V 390P	1	
C120	ECEA1CKS100	16V 10U	1	
C121	RCE1HKA47BG	50V 0.47U	1	
C122,23	ECEA1HKS010	50V 1U	2	
C124	ECBT1H101KB5	50V 100P	1	
C125	ECEA1CKS220	16V 22U	1	

Ref. No.	Part No.	Part Name & Description	Pcs	Remarks
C126	ECBT1H473ZF5	50V 0.047U	1	
C127	ECEA1CKS220	16V 22U	1	
C129,30	ECEA0JKS101	6.3V 100U	2	
C131	ECBT1H101KB5	50V 100P	1	
C132	ECBT1H102KB5	50V 1000P	1	
C133,34	ECBT1H270JUS	50V 27P	2	
C136	ECBT1H102KB5	50V 1000P	1	
C137	ECFR1E472KR	25V 4700P	1	
C138	ECBT1C103KS5	16V 0.01U	1	
C139	ECFR1E472KR	25V 4700P	1	
C141,42	ECEA1HKS010	50V 1U	2	
C143,44	ECBT1C472KR5	16V 4700P	2	
C147	ECBT1H102KB5	50V 1000P	1	
C148	ECBT1C103NS5	16V 0.01U	1	
C149	ECBT1H104ZF5	50V 0.1U	1	
C201-06	ECBT1H101KB5	50V 100P	6	
C209	ECBT1H102KB5	50V 1000P	1	
C301,02	ECA1CAK100XB	16V 10U	2	
C303,04	ECBT1H330J5	50V 33P	2	
C305,06	ECBT1H102KB5	50V 1000P	2	
C307,08	ECBT1E103ZF	25V 0.01U	2	
C309-12	ECA1CAK100XB	16V 10U	4	
C314	ECBT1H104ZF5	50V 0.1U	1	
C315-17	ECBT1H470J5	50V 47P	3	
C318	ECBT1H104ZF5	50V 0.1U	1	
C321,22	ECBT1H471KB5	50V 470P	2	
C323,24	ECBT1H102KB5	50V 1000P	2	
C325,26	ECA1CAK100XB	16V 10U	2	
C327,28	ECBT1H331KB5	50V 330P	2	
C329,30	ECA1CAK100XB	16V 10U	2	
C331,32	ECBT1H331KB5	50V 330P	2	
C333,34	ECBT1C333KR5	16V 3300P	2	
C335-38	ECQB1H103JZ	50V 0.01U	4	
C339	ECQV1H473JM3	50V 0.047U	1	HD310
C339	ECQV1H563JM3	50V 0.056U	1	HD510
C340	ECQV1H473JM3	50V 0.047U	1	HD310
C340	ECQV1H563JM3	50V 0.056U	1	HD510
C341	ECQV1H473JM3	50V 0.047U	1	HD310
C341	ECQV1H563JM3	50V 0.056U	1	HD510
C342	ECQV1H473JM3	50V 0.047U	1	HD310
C342	ECQV1H563JM3	50V 0.056U	1	HD510
C343	ECQV1H224JL3	50V 0.22U	1	HD310
C343	ECQV1H104JM3	50V 0.1U	1	HD510
C344	ECQV1H224JL3	50V 0.22U	1	HD310
C344	ECQV1H104JM3	50V 0.1U	1	HD510
C345	ECQB1H333JF3	50V 0.033U	1	HD310
C345	ECQV1H124JM3	50V 0.12U	1	HD510
C346	ECQB1H333JF3	50V 0.033U	1	HD310
C346	ECQV1R124JM3	50V 0.12U	1	HD510
C347	ECBT1H471KB5	50V 470P	1	HD310
C347	ECQB1H333JF3	50V 0.033U	1	HD510
C348	ECBT1H471KB5	50V 470P	1	HD310
C348	ECQB1H333JF3	50V 0.033U	1	HD510
C349	ECBT1H471KB5	50V 470P	1	HD310
C349	ECQB1H333JF3	50V 0.033U	1	HD510
C350	ECBT1H471KB5	50V 470P	1	HD310
C350	ECQB1R333JF3	50V 0.033U	1	HD510
C351	ECBT1H104ZF5	50V 0.1U	1	
C353-62	ECBT1H101KB5	50V 100P	10	
C401,02	ECA1EAM101XB	25V 100U	2	
C403,04	ECBT1H473KB5	50V 0.047U	2	
C405,06	ECA1CAK470KB	16V 47U	2	
C407,08	ECA1CAK101XB	16V 100U	2	
C409	ECBT1E103ZF	25V 0.01U	1	
C410	ECBT1H473KB5	50V 0.047U	1	
C411	ECA1CAK101XB	16V 100U	1	
C413	ECA1EAM101XB	25V 100U	1	
C414	ECEA0JKS101	6.3V 100U	1	
C415	ECBT1H473KB5	50V 0.047U	1	
C471,72	ECBT1H473KB5	50V 0.047U	2	
C481	ECBT1C105ZF5	16V 1U	1	
C482	ECBT1H104ZF5	50V 0.1U	1	
C483,84	ECBT1H473KB5	50V 0.047U	2	

Ref. No.	Part No.	Part Name & Description	Pcs	Remarks
C491,92	ECBT1H101KB5	50V 100P	2	
C493	ECEALVKS470	35V 470	1	
C501	ECEAOJKS101	6.3V 100U	1	HD510
C502	ECBT1E103ZF	25V 0.01U	1	HD510
C503,04	ECBT1R470J5	50V 47P	2	HD510
C505	ECBT1B561KB5	50V 560P	1	HD510
C506	ECBT1E103ZF	25V 0.01U	1	HD510
C507	ECEAOJKS101	6.3V 100U	1	HD510
C508	ECBT1H331KB5	50V 330P	1	HD510
C509	ECA1CAK100XB	16V 10U	1	HD510
C541	RCE1HKA3R3BG	50V 3.3U	1	
C601	ECUV1H103ZFN	50V 0.01U	1	
C702	ECUV1H180JCN	50V 18P	1	
C703	ECUV1H200JCN	50V 20P	1	
C704	ECEA1HKS2R2	50V 2.2U	1	
C705,06	ECUV1H104ZFN	50V 0.1U	2	
C707	RCE0JRC102BG	6.3V 1000U	1	
C708	ECUV1H103ZFN	50V 0.01U	1	
C709	ECEALCKS100	16V 10U	1	
C710	ECUV1H102KBN	50V 1000P	1	
C711,12	ECUV1H104ZFN	50V 0.1U	2	
C713	ECEA1HKS100	50V 10U	1	
C715,16	ECUV1H104ZFN	50V 0.1U	2	
C717,18	ECUV1H103ZFN	50V 0.01U	2	
C721	ECUV1H103ZFN	50V 0.01U	1	
C722	ECUV1H101JCN	50V 100P	1	
C781,82	ECEA1HKS010	50V 1U	2	
C792	ECEAOJKS101	6.3V 100U	1	
CF201	RLFFETNGD01L	CERAMIC FILTER	1	
CF202	RLFFETMGD01L	CERAMIC FILTER	1	
CN101A	RJT100W07	CONNECTOR (7P)	1	
CN101B	RJU100W07	CONNECTOR (7P)	1	
CN102A	RJT100W07	CONNECTOR (7P)	1	
CN102B	RJU100W07	CONNECTOR (7P)	1	
CN103A	RJT057W007-1	CONNECTOR (7P)	1	
CN103B	RJU057W007	CONNECTOR (7P)	1	
CN104A	RJT057W007-1	CONNECTOR (7P)	1	
CN104B	RJU057W007	CONNECTOR (7P)	1	
CN105A	RJT057W007-1	CONNECTOR (7P)	1	
CN105B	RJU057W007	CONNECTOR (7P)	1	
CN701A	RJSLA6814	CONNECTOR (14P)	1	
CN701B	RJSLA6214-1	CONNECTOR (14P)	1	
CN702A	RJSLA6814	CONNECTOR (14P)	1	
CN702B	RJSLA6214-1	CONNECTOR (14P)	1	
CN703A	RJT066H05A	CONNECTOR (5P)	1	
CN703B	RJU066H05	CONNECTOR (5P)	1	
D101	MA4051M	DIODE	1	△
D301	MA4051M	DIODE	1	△
D401,02	MA4075M	DIODE	2	△
D403	MA4082LTA	DIODE	1	△
D404	MA185TA	DIODE	1	
D481-84	MA719TA	DIODE	4	
D491	MA4043M	DIODE	1	
D492	MA4051M	DIODE	1	
D541,42	MA165	DIODE	2	
D601	3LR325VCT31	LED	1	
D701	MA111TX	DIODE	1	
D703,04	1SS380TE-17	DIODE	2	
D705	MA111TX	DIODE	1	
D706	1SS380TE-17	DIODE	1	
D711	MA111TX	DIODE	1	
D713,14	MA111TX	DIODE	2	HD510
FL701	RSL0273-F	FL	1	
IC101	LA1833MN-TLM	IC	1	
IC102	LC72131MDTLM	IC	1	
IC301	M5218AFP3	IC	1	
IC302	M62433AFP	IC	1	
IC501	LC72722PMTLM	IC	1	HD510
IC701	M30217MAA200	IC	1	

Ref. No.	Part No.	Part Name & Description	Pcs	Remarks
JK101	RJE5210M	JACK, ANTENNA	1	
JK201	SJF3069-20N	JACK, EXT OUT/IN	1	
JK401	RJT065K20	SYSTEM CONNECTOR (20P)	1	
JK402	RJT065K19	SYSTEM CONNECTOR (19P)	1	
L101,02	ELESNR68MA	COIL	2	
L103	ELEXTR47MA9	COIL	1	
L501,02	RLQA100JT-Y	COIL	2	HD510
L541,42	RLQA100JT-Y	COIL	2	
L701	RLBN300AV-W	COIL	1	
L702-04	RLBN601V-W	COIL	3	
L706	RLBN601V-W	COIL	1	
L707	RLBN300AV-W	COIL	1	
P2	RPG4718	PACKING CASE (TUNER)	1	
P3	RPN1266	CUSHION	1	
P6	SPP740-1	PROTECTION BAG (TUNER)	1	
PCB1	REP2592C-T	TUNER P.C.B.	1	(RTL)
PCB2	REP2904C-M	MAIN P.C.B.	1	HD310 (RTL)
PCB2	REP2904B-M	MAIN P.C.B.	1	HD510 (RTL)
PCB3	REP2953B-S	PANEL P.C.B.	1	HD310 (RTL)
PCB3	REP2953A-S	PANEL P.C.B.	1	HD510 (RTL)
Q101,02	2SC2787FK	TRANSISTOR	2	
Q106	UN4111	TRANSISTOR	1	
Q110	2SC3311AR	TRANSISTOR	1	
Q401	2SD2137PQTA	TRANSISTOR	1	△
Q402	2SB1417PQTA	TRANSISTOR	1	△
Q403	2SC3940AQSTA	TRANSISTOR	1	△
Q405	DTB123YSTP	TRANSISTOR	1	
Q406	DTC114ESTP	TRANSISTOR	1	
Q407	2SC3311ATA	TRANSISTOR	1	
Q541,42	2SC3311ATA	TRANSISTOR	2	
Q543	DTC143XSTP	TRANSISTOR	1	
Q701	UN5214TX	TRANSISTOR	1	
Q702,03	2SD1819ATX	TRANSISTOR	2	
R102	ERDS2FJ472	1/4W 4.7K	1	
R103	ERDS2FJ101	1/4W 100	1	
R104	ERDS2FJ103	1/4W 10K	1	
R105	ERDS2FJ471	1/4W 470	1	
R106	ERDS2FJ474	1/4W 470K	1	
R107	ERDS2FJ331	1/4W 330	1	
R108	ERDS2FJ474	1/4W 470K	1	
R109	ERDS2FJ331	1/4W 330	1	
R110	ERDS2FJ102	1/4W 1K	1	
R111	ERDS2FJ391	1/4W 390	1	
R112	ERDS2FJ104	1/4W 100K	1	
R113	ERDS2FJ103	1/4W 10K	1	
R114	ERDS2FJ562	1/4W 5.6K	1	
R115	ERDS2FJ561	1/4W 560	1	
R116	ERDS2FJ102	1/4W 1K	1	
R117	ERDS2FJ683	1/4W 68K	1	
R118	ERDS2FJ332	1/4W 3.3K	1	
R119	ERDS2FJ103	1/4W 10K	1	
R120	ERDS2FJ473	1/4W 47K	1	
R121	ERDS2FJ223	1/4W 22K	1	
R122	ERDS2FJ272	1/4W 2.7K	1	
R123	ERDS2FJ683	1/4W 68K	1	
R124	ERDS2FJ271	1/4W 270	1	
R125	ERDS2FJ471	1/4W 470	1	
R126	ERDS2FJ152	1/4W 1.5K	1	
R127	ERDS2FJ471	1/4W 470	1	
R128	ERDS2FJ820	1/4W 82	1	
R129	ERDS2FJ273	1/4W 27K	1	
R130	ERDS2FJ103	1/4W 10K	1	
R131	ERDS2FJ680	1/4W 68	1	
R132	ERDS2FJ103	1/4W 10K	1	
R133	ERDS2FJ102	1/4W 1K	1	

Ref. No.	Part No.	Part Name & Description	Pcs	Remarks
R134	ERDS2FJ471	1/4W 470	1	
R135-37	ERDS2FJ102	1/4W 1K	3	
R138, 39	ERDS2FJ332	1/4W 3.3K	2	
R140	ERDS2FJ472	1/4W 4.7K	1	
R141, 42	ERDS2FJ102	1/4W 1K	2	
R143	ERDS2FJ223	1/4W 22K	1	
R145, 46	ERDS2FJ104	1/4W 100K	2	
R201, 02	ERDS2FJ102	1/4W 1K	2	
R203, 04	ERDS2FJ104	1/4W 100K	2	
R205, 06	ERDS2FJ102	1/4W 1K	2	
R207, 08	ERDS2FJ104	1/4W 100K	2	
R301-04	ERDS2FJ471	1/4W 470	4	
R305, 06	ERDS2FJ123	1/4W 12K	2	
R307, 08	ERDS2FJ103	1/4W 10K	2	
R313, 14	ERDS2FJ102	1/4W 1K	2	
R315, 16	ERDS2FJ223	1/4W 22K	2	
R319, 20	ERDS2FJ332	1/4W 3.3K	2	
R325	ERDS2FJ102	1/4W 1K	1	
R326	ERDS2FJ103	1/4W 10K	1	
R329-32	ERDS2FJ472	1/4W 4.7K	4	
R333, 34	ERDS2FJ102	1/4W 1K	2	
R337, 38	ERDS2FJ223	1/4W 22K	2	
R339, 40	ERDS2FJ103	1/4W 10K	2	
R341, 42	ERDS2FJ102	1/4W 1K	2	
R343, 44	ERDS2FJ103	1/4W 10K	2	
R345, 46	ERDS2FJ102	1/4W 1K	2	
R347, 48	ERDS2FJ103	1/4W 10K	2	
R349, 50	ERDS2FJ272	1/4W 2.7K	2	
R351, 52	ERDS2FJ822	1/4W 8.2K	2	
R353, 54	ERDS2FJ222	1/4W 2.2K	2	
R355, 56	ERDS2FJ103	1/4W 10K	2	
R357, 58	ERDS2FJ102	1/4W 1K	2	
R359, 60	ERDS2FJ103	1/4W 10K	2	
R361, 62	ERDS2FJ472	1/4W 4.7K	2	
R363, 64	ERDS2FJ103	1/4W 10K	2	
R367, 68	ERDS2FJ103	1/4W 10K	2	
R369, 70	ERDS2FJ333	1/4W 33K	2	
R401, 02	ERD2FCJ4R7	1/4W 4.7	2	△
R403, 04	ERDS2FJ102	1/4W 1K	2	
R405	ERD2FCG100	1/4W 10	1	△
R406	ERDS2FJ102	1/4W 1K	1	
R407	ERDS2FJ221	1/4W 220	1	
R408-11	ERDS2FJ102	1/4W 1K	4	
R412, 13	ERD16TJ000T	1/4W 0	2	
R481, 82	ERDS2FJ101	1/4W 100	2	
R491, 92	ERDS2FJ151	1/4W 150	2	
R493	ERDS2FJ103	1/4W 10K	1	
R501-03	ERDS2FJ102	1/4W 1K	3	HD510
R504	ERDS2FJ101	1/4W 100	1	HD510
R505	ERDS2FJ332	1/4W 3.3K	1	HD510
R507	ERDS2FJ101	1/4W 100	1	HD510
R509	ERDS2FJ101	1/4W 100	1	HD510
R530	ERDS2FJ473	1/4W 47K	1	
R541	ERDS2FJ473	1/4W 47K	1	
R542, 43	ERDS2FJ472	1/4W 4.7K	2	
R544	ERDS2FJ223	1/4W 22K	1	
R545-47	ERDS2FJ103	1/4W 10K	3	
R548	ERDS2FJ331	1/4W 330	1	
R549, 50	ERDS2FJ103	1/4W 10K	2	
R551, 52	ERDS2FJ102	1/4W 1K	2	
R601	ERJ6GEYJ332V	1/10W 3.3K	1	
R602	ERJ6GEYJ222V	1/10W 2.2K	1	
R603	ERJ6GEYJ182V	1/10W 1.8K	1	
R604	ERJ6GEYJ152V	1/10W 1.5K	1	
R605	ERJ6GEYJ122V	1/10W 1.2K	1	
R606	ERJ6GEYJ102V	1/10W 1K	1	
R607	ERJ6GEYJ821V	1/10W 820	1	
R611	ERJ6GEYJ471V	1/10W 470	1	
R701	ERJ6GEYJ102V	1/10W 1K	1	
R702	ERJ6GEYJ103V	1/10W 10K	1	
R703	ERJ6GEYJ104V	1/10W 100K	1	
R704	ERJ6GEYDR00	1/10W 0	1	
R706	ERJ6GEYJ102V	1/10W 1K	1	

Ref. No.	Part No.	Part Name & Description	Pcs	Remarks
R708	ERJ6GEYJ824V	1/10W 820K	1	
R709, 10	ERJ6GEYJ102V	1/10W 1K	2	
R721	ERJ6GEYJ153V	1/10W 15K	1	
R722, 23	ERJ6GEYJ331V	1/10W 330	2	
R724	ERJ6GEYJ102V	1/10W 1K	1	
R725	ERJ6GEYJ101V	1/10W 100	1	
R726, 27	ERJ6GEYJ331V	1/10W 330	2	
R728, 29	ERJ6GEYJ102V	1/10W 1K	2	
R730	ERJ6GEYJ103V	1/10W 10K	1	
R733	ERJ6GEYJ101V	1/10W 100	1	
R734	ERJ6GEYJ104V	1/10W 100K	1	
R738	ERJ6GEYJ101V	1/10W 100	1	
R739-42	ERJ6GEYJ102V	1/10W 1K	4	
R746-51	ERJ6GEYJ103V	1/10W 10K	6	
R752-57	ERJ6GEYJ102V	1/10W 1K	6	
R758, 59	ERJ6GEYJ101V	1/10W 100	2	
R760	ERJ6GEYJ102V	1/10W 1K	1	
R761	ERJ6GEYJ472V	1/10W 4.7K	1	
R762	ERJ6GEYJ104V	1/10W 100K	1	
R763	ERJ6GEYJ223V	1/10W 22K	1	
R764	ERJ6GEYJ103V	1/10W 10K	1	
R768	ERJ6GEYJ102V	1/10W 1K	1	
R769	ERJ6GEYJ103V	1/10W 10K	1	
R781, 82	RRY0001	RESISTOR-NETWORK	2	
RJ721-23	ERJ8GEY0R00V	CHIP JUMPER	3	
S601-08	EVQ11G05R	SW, PUSH	8	
X102	RLFDT13DD	OSCILLATOR	1	
X103	RSXC7M20S05T	OSCILLATOR	1	
X501	RSXC4M3S02T	OSCILLATOR	1	HD510
X701	RSXY10M0M01T	OSCILLATOR	1	
X702	RSXD32K7S05	OSCILLATOR	1	
Z101	RLA2Z006M-T	COMPONENT COMBINATION	1	
Z102	RLI2Z022M-T	COMPONENT COMBINATION	1	
Z120	RAL0035	FM FRONT END	1	
Z601	RCDGP1U26XD	REMOTE SENSOR	1	

13 Cabinet Parts Location

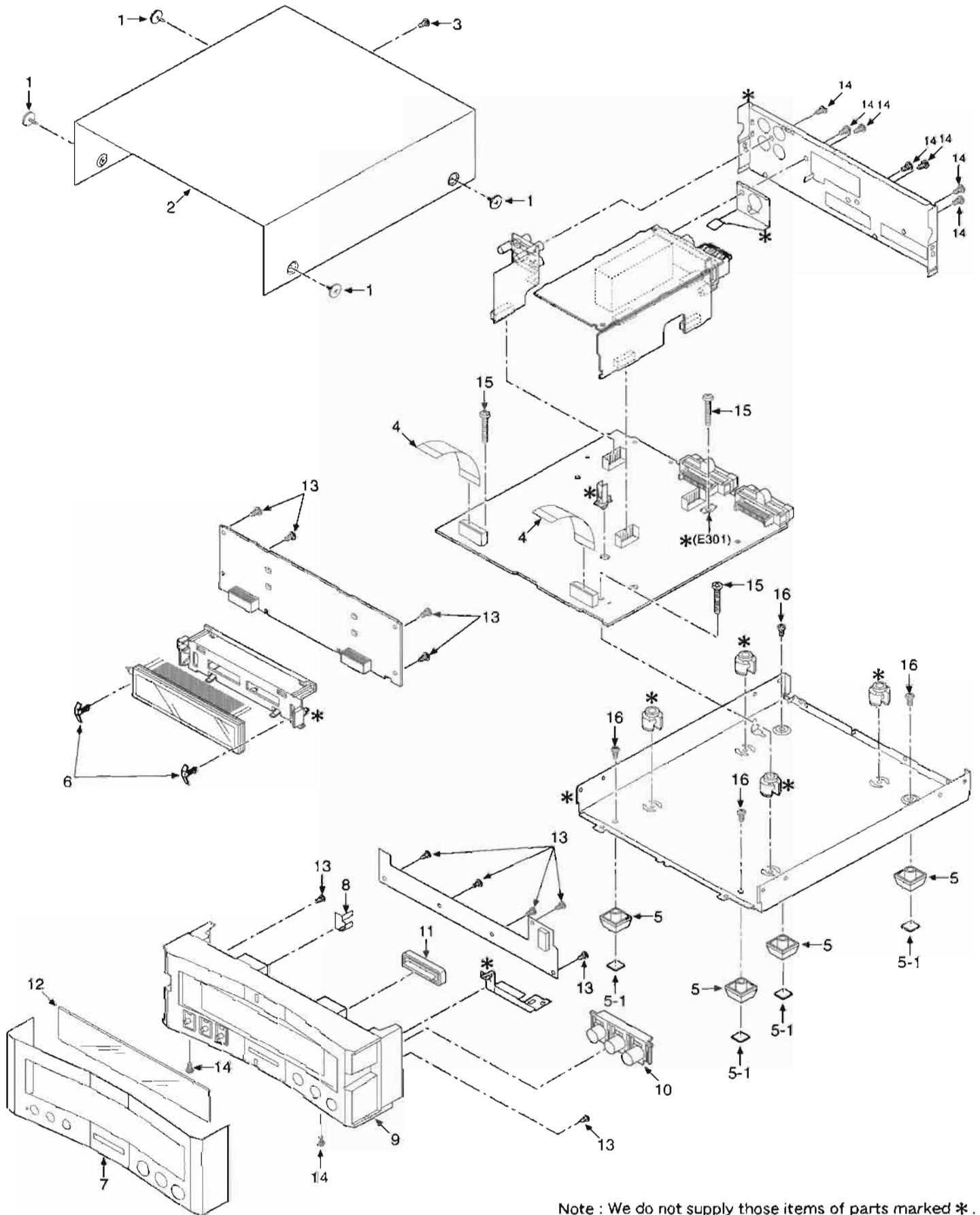

Note : We do not supply those items of parts marked *.