

Service Manual

Tuner

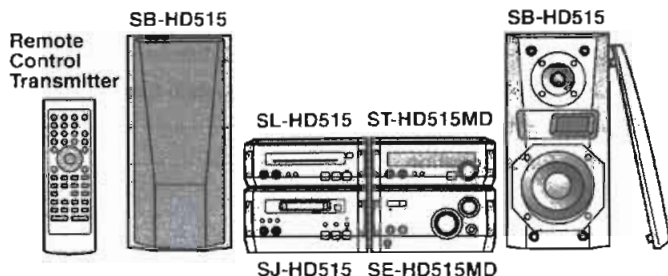

ST-HD515MD

Colour

(S).....Silver Type

Area

(EG).....Europe.

Because of unique interconnecting cables, when a component requires service, send or bring in the entire system.

System	SC-HD515MD
Tuner	ST-HD515MD
Amplifier	SE-HD515MD
CD Player	SL-HD515
MD Deck	SJ-HD515
Speakers*	SB-HD515

* : Made in Spain.

Specifications

Pre-amplifier section

Input sensitivity/impedance:	
EXT IN;	300 mV/15 k Ω
Output level/impedance:	
EXT OUT;	250 mV/1.5 k Ω

Tuner section

FM Frequency range:	87.50 – 108.00 MHz (0.05 MHz steps)
FM Antenna terminal(s):	75 Ω (unbalanced)
AM Frequency range:	522 – 1629 kHz (9 kHz steps) 520 – 1630 kHz (10 kHz steps)

Timer section

Clock:	Quartz - lock type
Function:	Play timer (1 time or everyday), Rec timer (1 time or everyday), Sleep (120 min, 30 min intervals)

General

Dimensions (W×H×D):	200×76×261.5 mm
Weight:	1.2 kg

Notes: Specifications are subject to change without notice.
Weight and dimensions are approximate.

⚠ WARNING

This service information is designed for experienced repair technicians only and is not designed for use by the general public. It does not contain warnings or cautions to advise non-technical individuals of potential dangers in attempting to service a product. Products powered by electricity should be serviced or repaired only by experienced professional technicians. Any attempt to service or repair the product or products dealt with in this service information by anyone else could result in serious injury or death.

Technics®

© 2000 Matsushita Electric Industrial Co., Ltd. All rights reserved. Unauthorized copying and distribution is a violation of law.

CONTENTS

	Page		Page
1 Note	2	8 Type Illustration of ICs, Transistors and Diodes	6
2 Blue LED	2	9 Schematic Diagram Notes	6
3 Before Repair	2	10 Schematic Diagram	7
4 Location of Controls	2	11 Printed Circuit Board Diagram	14
5 Operation Checks and Component Replacement Procedures	3	12 Wiring Connection Diagram	18
5.1. Checking for the tuner P.C.B. and FL P.C.B.	3	13 Block Diagram	19
5.2. Checking for the main P.C.B.	3	14 Terminal Function of ICs	22
6 To Supply Power Source and Signal Check	4	14.1. IC302 (M62433AFP):Digital Sound Controller	22
7 Self-Diagnostic Function	5	14.2. IC701 (M30218MAA108):FL Drive/System Control	22
7.1. To display the malfunction code	5	15 Replacement Parts List	24
7.2. To return to the normal display	5	16 Cabinet Parts Location	27
7.3. Display contents	5		

1 Note

Refer to the service manual for Model No. SE-HD515MD (ORDER No. AD0003056C2) for information on Accessories and Packaging.

2 Blue LED

- The blue LED mounted to each sides of front panel is very sensitive to static electricity. When handling the LED base plate, be very careful about it.
- Do not replace the blue LED by itself because it may be subject to electrostatic breakdown or deterioration in quality. When replacing the LED base plate, be sure to replace L and R sides simultaneously to adjust the brightness. For configuration at the time of supply of replacement parts, refer to Printed Circuit Board Diagram.

4 Location of Controls

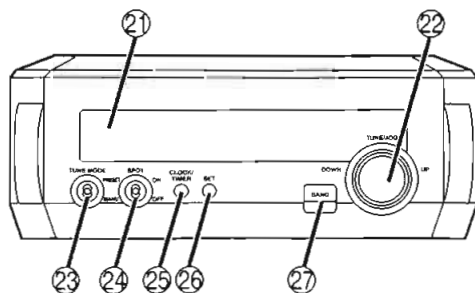

- ②① Display panel
The display also shows information for the MD deck, CD player, and amplifier.
- ②② Station selection and JOG dial (TUNE/JOG)
- ②③ Tuning mode switch (TUNE MODE)
- ②④ Sidelight switch (SPOT)
- ②⑤ Clock/timer button (CLOCK/TIMER)
- ②⑥ Set button (SET)
- ②⑦ Band select button (BAND)

3 Before Repair

This equipment (ST-HD515MD), which is a component of the system, is supplied with power from the Amplifier (SE-HD515MD). When repairing this equipment or checking operation of the system, be sure to connect to the amplifier with it.

Power supply and operation check in the state of it as a single equipment is impracticable.

5 Operation Checks and Component Replacement Procedures

- This section describes procedures for checking the operation of the major printed circuit boards and replacing the main components.
- For reassembly after operation checks or replacement, reverse the respective procedures. Special reassembly procedures are described only when required.

5.1. Checking for the tuner P.C.B. and FL P.C.B.

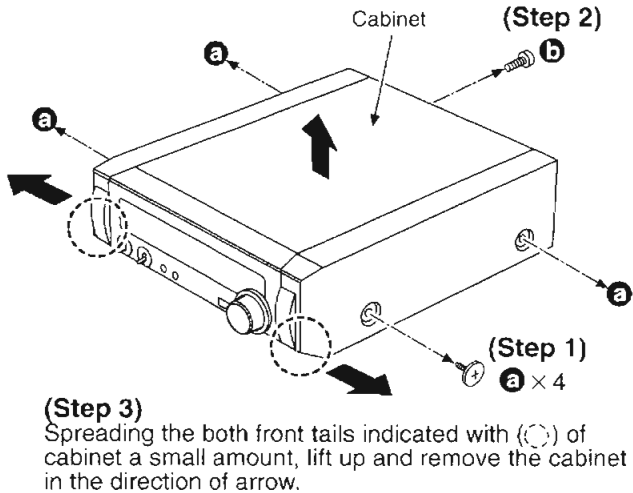

- Check the tuner P.C.B. and FL P.C.B. as shown below.

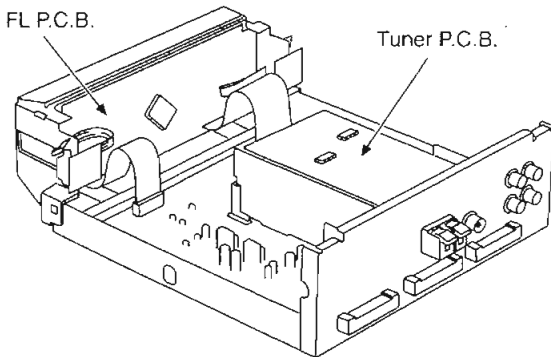

5.2. Checking for the main P.C.B.

- Follow the (Step 1) - (Step 3) of item 5.1.

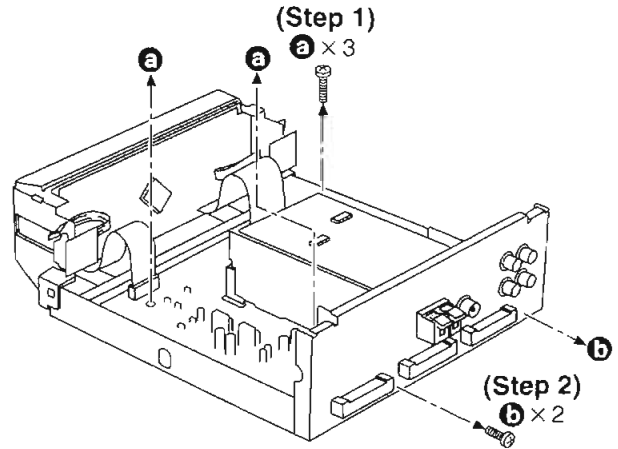

NOTE:

When insutalling the main P.C.B., make sure that the holes of main P.C.B. are aligned with the ribs of bottom cabinet.

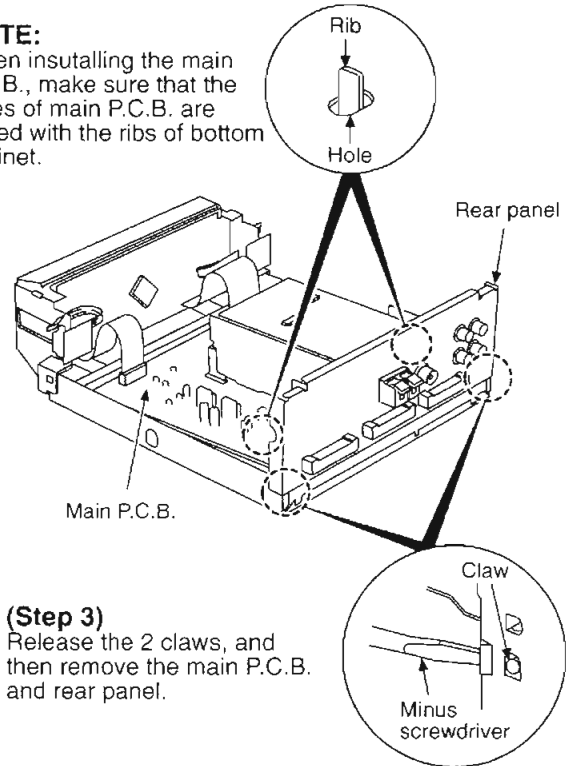

- Check the main P.C.B. as shown below.

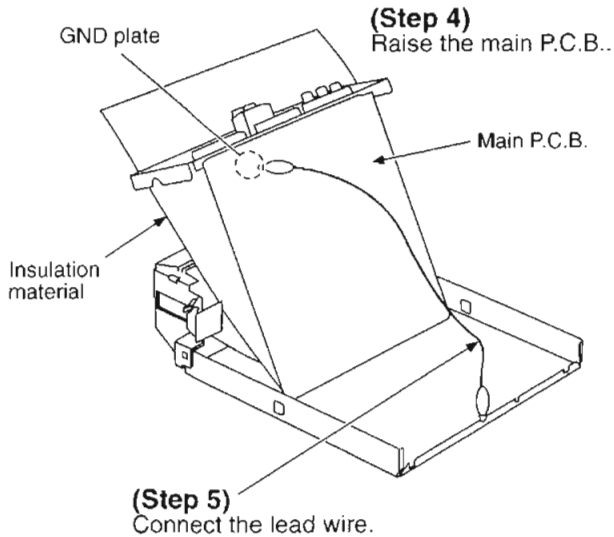

6 To Supply Power Source and Signal Check

To operate the unit ST-HD515MD normally, it is necessary to connect to the unit SE-HD515MD. When operating the unit ST-HD515MD, be sure to connect to the unit SE-HD515MD by connection cable.

1. Short the section J210 (A.GND) and J212 (D.GND), and as well as the section between J403 (CT) and J212 (D.GND). Refer to Fig. 6-1.
2. Connect with the Amplifier (SE-HD515MD). Refer to Fig. 6-1.
3. Connect the AC power supply cord to the Amplifier (SE-

HD515MD). Refer to Fig. 6-1.

4. Connect the speakers to speaker terminal. Refer to Fig. 6-1.
5. Turn on the power of the Amplifier (SE-HD515MD).
6. Press INPUT SELECTOR to select the external source (EXT) of the Amplifier (SE-HD515MD).
7. Input a sound signal to external input terminal of the Tuner (ST-HD515MD) and confirm to be outputted from the speaker. (Both High and Low.)

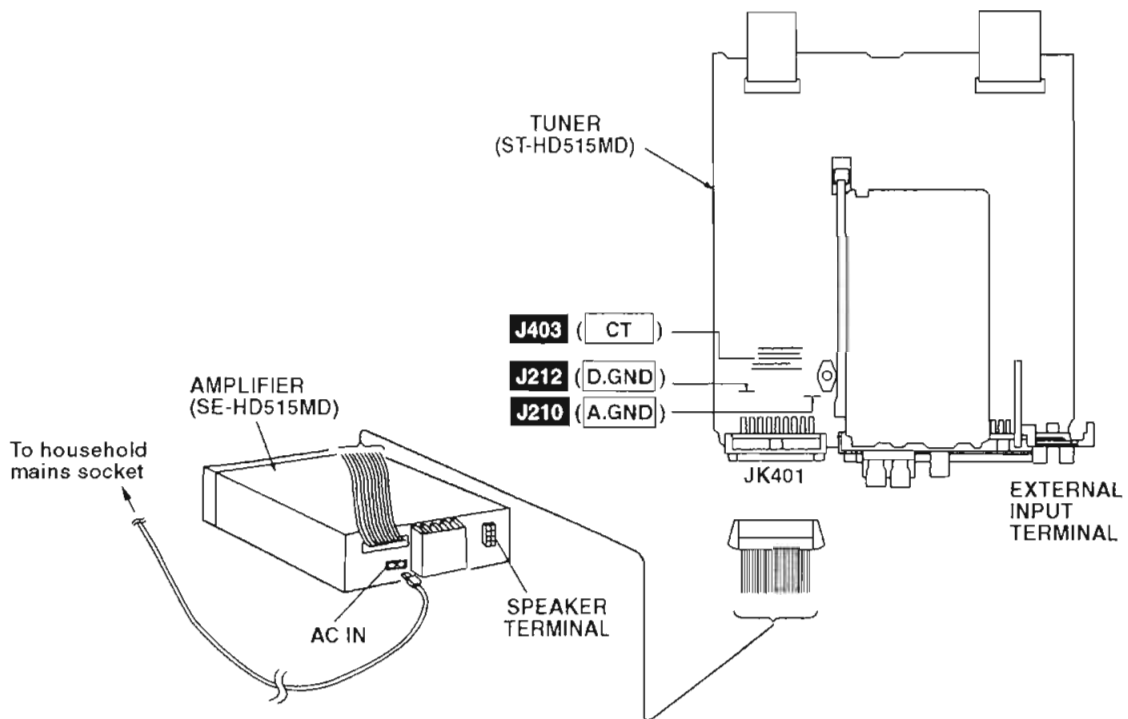

Fig. 6-1.

7 Self-Diagnostic Function

This unit is equipped with a self-diagnostic function which, in the event of a malfunction, automatically displays a code indicating the nature of the malfunction.

Use this self-diagnostic function when servicing the unit.

7.1. To display the malfunction code

- U70 CD:** Automatically displays on the tuner when a malfunction occurs. Refer to Fig. 7-1.
- U70 MD:** Automatically displays on the tuner when a malfunction occurs. Refer to Fig. 7-1.
- F61:** Automatically displays on the tuner when a malfunction occurs. Refer to Fig. 7-1.

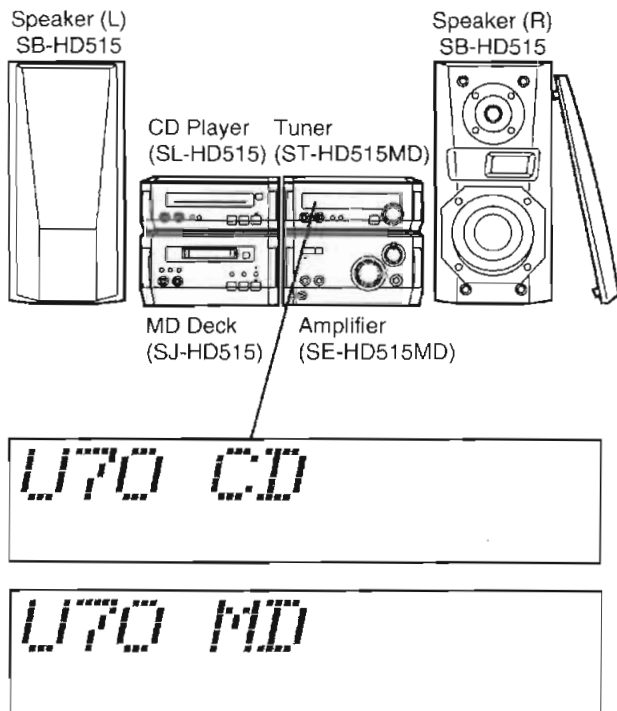

Fig. 7-1.

7.2. To return to the normal display

1. For U70 CD/U70 MD

- Press any operation button on the tuner.
- To re-display the code, switch the power off (POWER STANDBY button), and then switch power back on again.

2. For F61

- If F61 is displayed, the power will automatically be switched off.
- F61 will be displayed for 3 seconds, and then the clock will be displayed.
- To re-display the code, switch the power on. F61 will be re-displayed, and then after 3 seconds the clock will be displayed and the power will automatically switch off.

7.3. Display contents

7.3.1. U70 CD/U70 MD (displayed automatically)

• Problem or condition

A bus-line communications error has occurred as a result of the flat cables being inserted incorrectly, thus preventing the system from operating.

1. If U70 is displayed on the tuner, the CD Player or MD deck cannot be operated by remote control.

• Correction Procedure

1. To check for correct insertion of the flat cables.
 - Insert each connector until you hear a click.
 - Insert the flat cables at the back of the unit in the order indicated. Refer to Fig. 7-2.

Make sure the white side of the cable is on your right side. Refer to Fig. 7-3.

2. Breakage of the flat cables. (Check and replace.)

3. If the problem is not corrected by items 1 and 2 above, this indicates a faulty IC.

ST-HD515MD:

IC701 (M30218MAA108)

SL-HD515:

IC403 (LC66358C4K97)

SJ-HD515:

IC10 (MN101D03DAA1)

Check these ICs and replace.

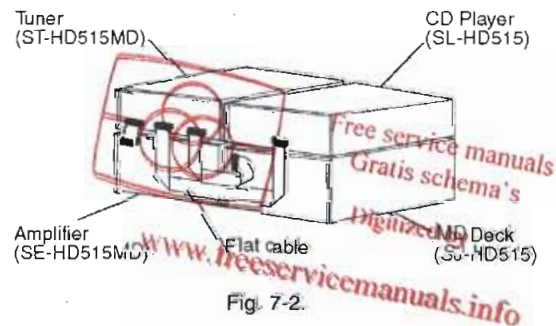

Fig. 7-2.

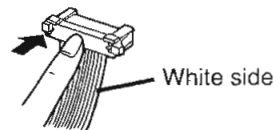

Fig. 7-3.

7.3.2. F61



• Problem or condition

When the power switch is switched on, it automatically switches back off, making it impossible to switch power on.

• Correction procedure

Faulty the Amplifier (SE-HD515MD) output IC (IC501 and IC502). (When a DC voltage is applied to speaker terminals.)

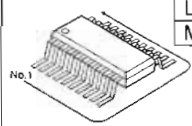
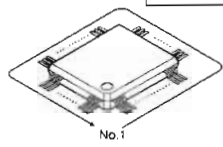
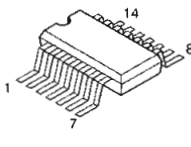
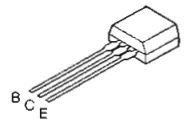
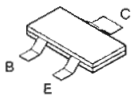
8 Type Illustration of ICs, Transistors and Diodes

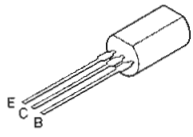
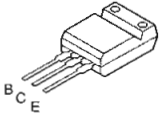
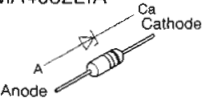
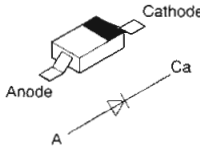
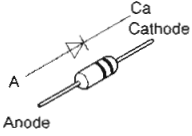
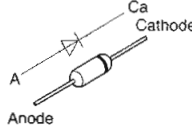
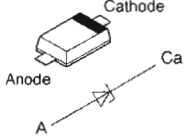
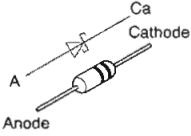
 <table border="1"> <tr><td>M5218AFPE3</td><td>8PIN</td></tr> <tr><td>LA1833MN-TLM</td><td>24PIN</td></tr> <tr><td>LC72131MDTLM</td><td>20PIN</td></tr> <tr><td>LC72722PMTLM</td><td>24PIN</td></tr> <tr><td>M5M34051FPE1</td><td>16PIN</td></tr> </table>	M5218AFPE3	8PIN	LA1833MN-TLM	24PIN	LC72131MDTLM	20PIN	LC72722PMTLM	24PIN	M5M34051FPE1	16PIN	 <table border="1"> <tr><td>M62433AFP</td><td>80PIN</td></tr> <tr><td>M30218MAA108</td><td>100PIN</td></tr> </table>	M62433AFP	80PIN	M30218MAA108	100PIN		
M5218AFPE3	8PIN																
LA1833MN-TLM	24PIN																
LC72131MDTLM	20PIN																
LC72722PMTLM	24PIN																
M5M34051FPE1	16PIN																
M62433AFP	80PIN																
M30218MAA108	100PIN																
2SD1819ATX 2SB709ASTX UN5214TX 	 2SC2787LTA 2SC3311ARSTA 2SC3311ATA UN4111TA UN4115TA	 2SC3940AQSTA	 2SB1417PQTA 2SD2137PQTA	 MA4043MTA MA4051MTA MA4075HTA MA4082LTA													
MA111TX 1SS380TE-17 	 MA185TA	 MA165TA	 UDZ2R0BTE-17	 MA719TA													

9 Schematic Diagram Notes

- This schematic diagram may be modified at any time with the development of new technology.

Notes:

S601:	Sidelight switch (SPOT)
S602:	Tuning mode switch (TUNE MODE)
S603:	Band select switch (BAND)
S604:	Set switch (SET)
S605:	Clock/timer switch (CLOCK/TIMER)
VR601:	Station selection and JOG dial (TUNE/JOG)

- Indicated voltage values are the standard values for the unit measured by the DC electronic circuit tester (high-impedance) with the chassis taken as standard. Therefore, there may exist some errors in the voltage values, depending on the internal impedance of the DC circuit tester.

No mark : FM
() : AM

- Important safety notice:

Components identified by \triangle mark have special characteristics important for safety.

Furthermore, special parts which have purposes of fire-retardant (resistors), high-quality sound (capacitors), low-noise (resistors), etc. are used.

When replacing any of components, be sure to use only manufacturer's specified parts shown in the parts list.

- Caution!**

IC and LSI are sensitive to static electricity.

Secondary trouble can be prevented by taking care during repair.







Cover the parts boxes made of plastics with aluminum foil.

Ground the soldering iron.

Put a conductive mat on the work table.

Do not touch the legs of IC or LSI with the fingers directly.

- Voltage and signal line

	: Positive voltage line
	: Negative voltage line
	: FM signal line
	: FM OSC signal line
	: AM signal line
	: AM OSC signal line

10 Schematic Diagram

SCHEMATIC DIAGRAM-1

NOTE:
The number which noted at the connectors on the schematic diagram as "SCHEMATIC DIAGRAM-1" or "SCHEMATIC DIAGRAM-2" indicates the schematic diagram serial number located on the left corner in the schematic diagram.

A TUNER CIRCUIT

→ : POSITIVE VOLTAGE LINE
 ◀◀ : FM OSC SIGNAL LINE
 ▶▶ : AM OSC SIGNAL LINE
 ◀ : FM SIGNAL LINE
 ▶ : AM SIGNAL LINE

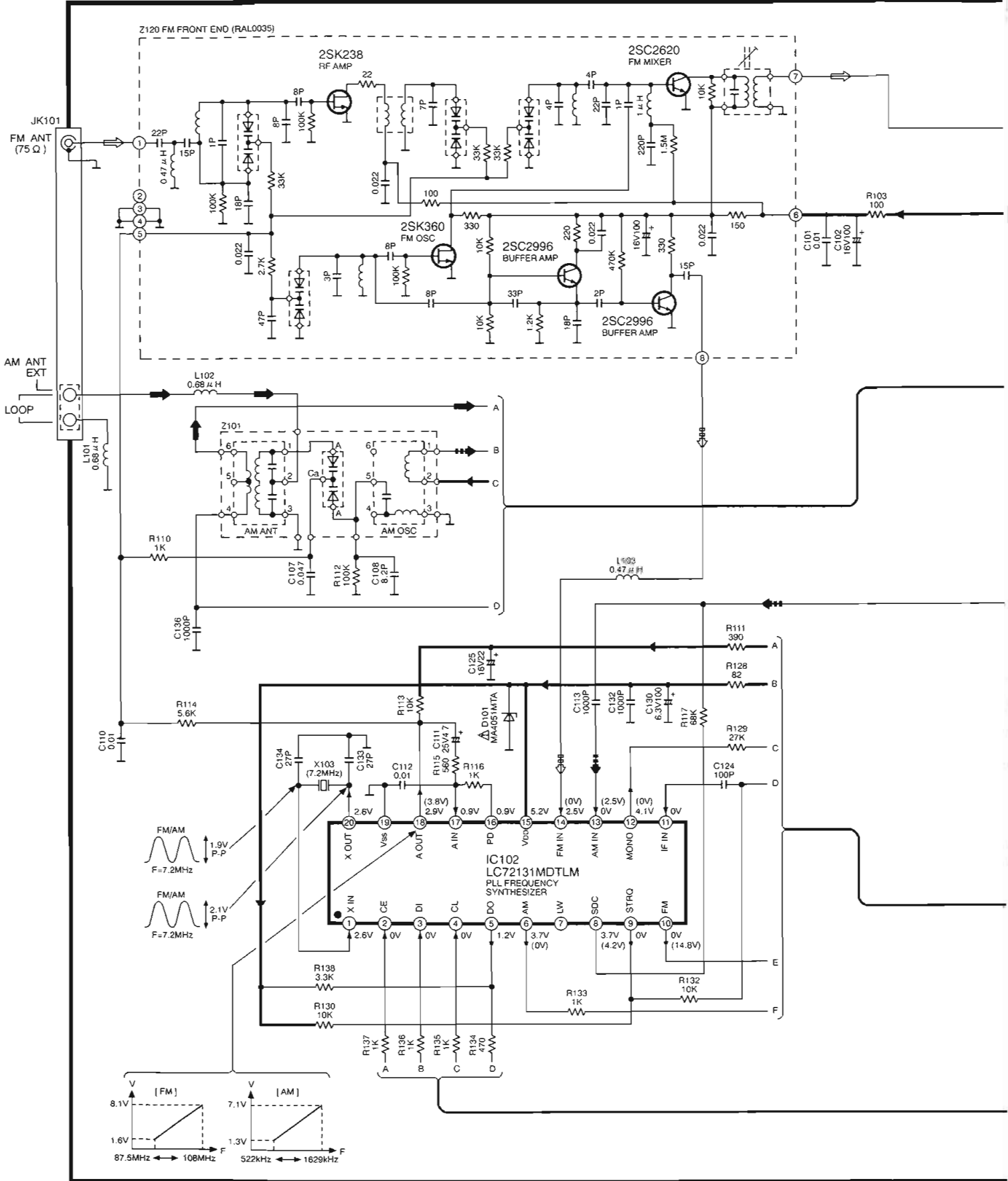

SCHEMATIC DIAGRAM-2

→ : POSITIVE VOLTAGE LINE ⇨ : FM SIGNAL LINE → : AM SIGNAL LINE ⇨⇨ : AM OSC SIGNAL LINE

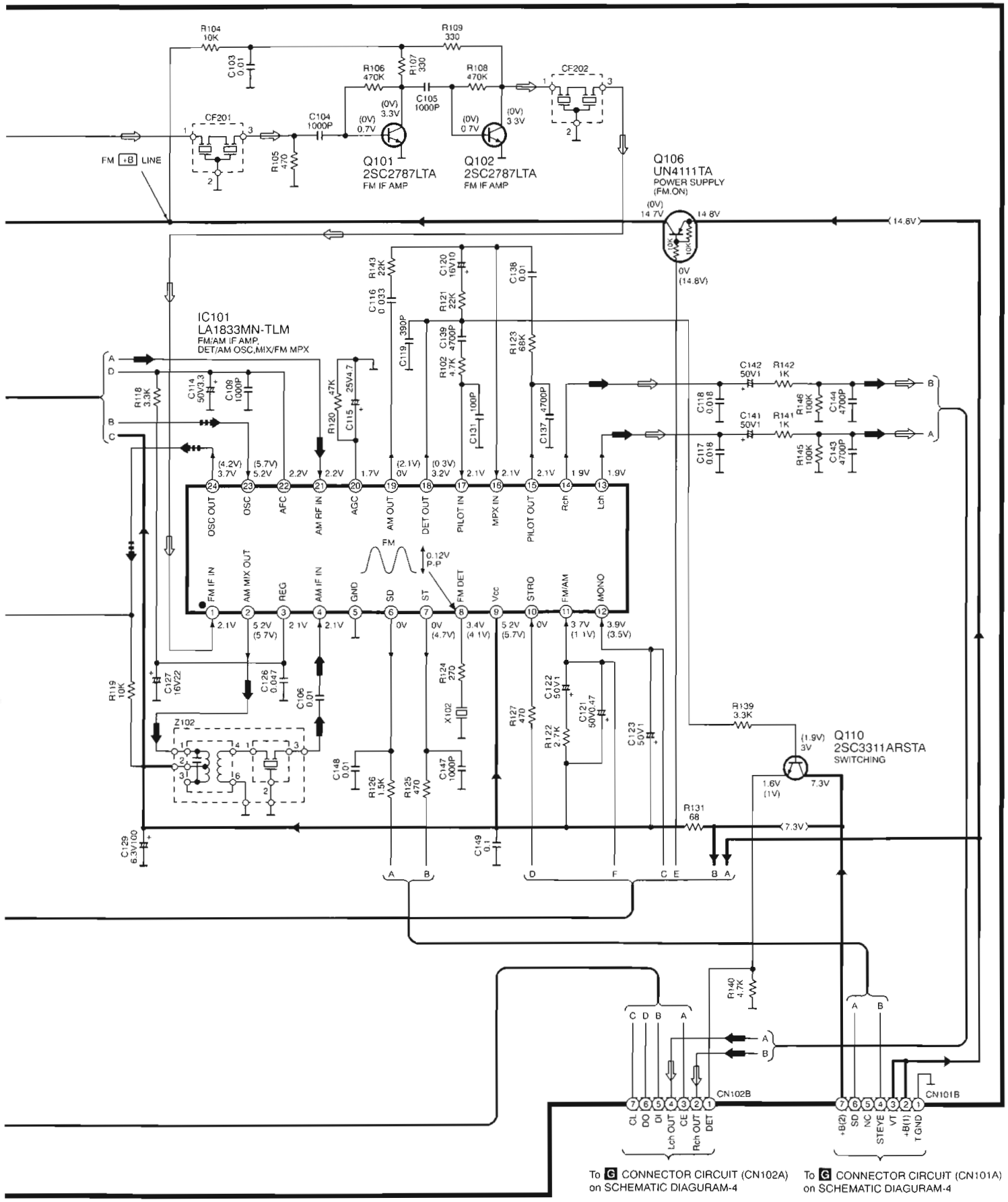

To **G** CONNECTOR CIRCUIT (CN102A) on SCHEMATIC DIAGRAM-4

To **G** CONNECTOR CIRCUIT (CN101A) on SCHEMATIC DIAGRAM-4

SCHEMATIC DIAGRAM-3

B FL CIRCUIT

→ : POSITIVE VOLTAGE LINE - → : NEGATIVE VOLTAGE LINE

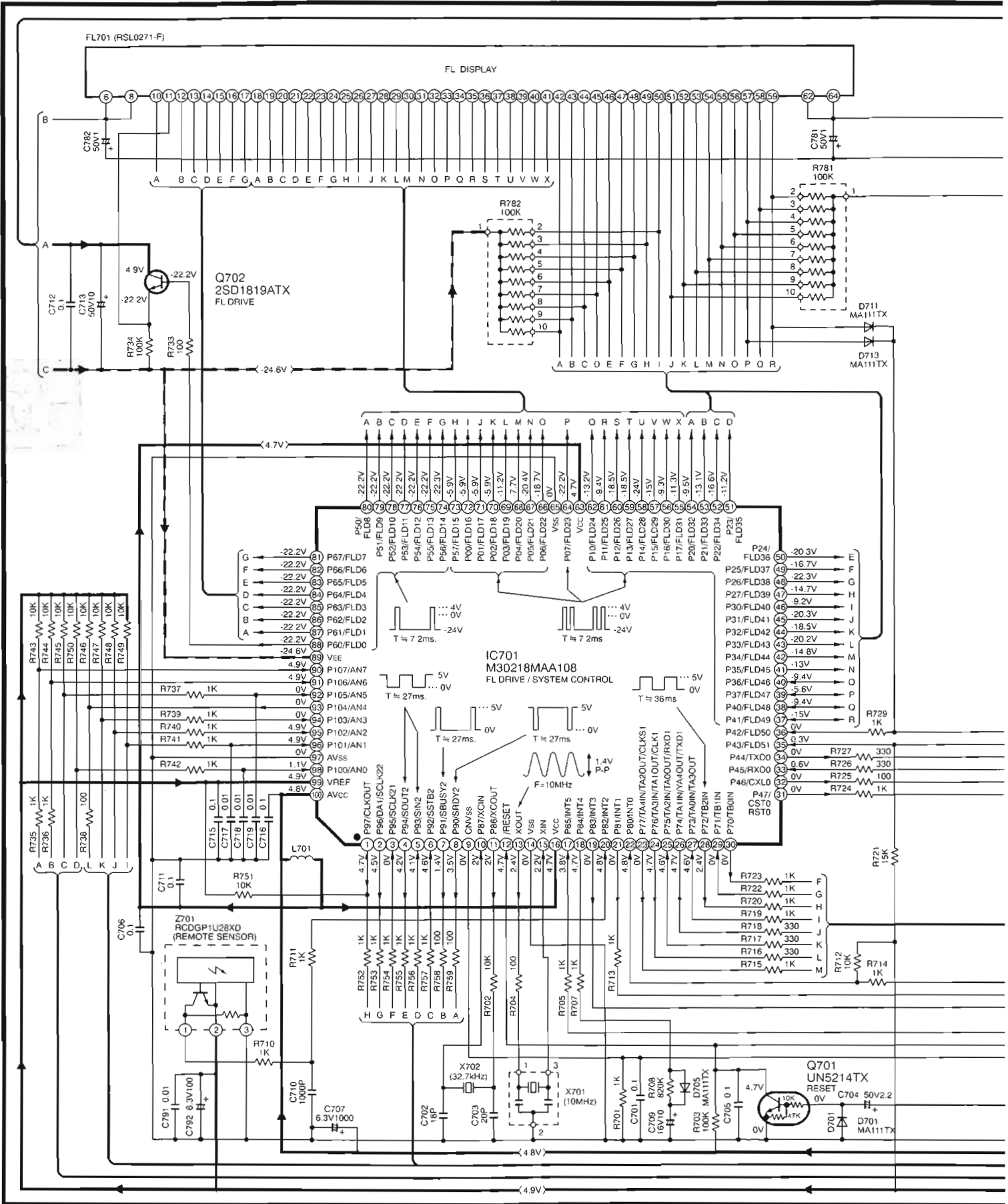

SCHEMATIC DIAGRAM-4

C OPERATION CIRCUIT

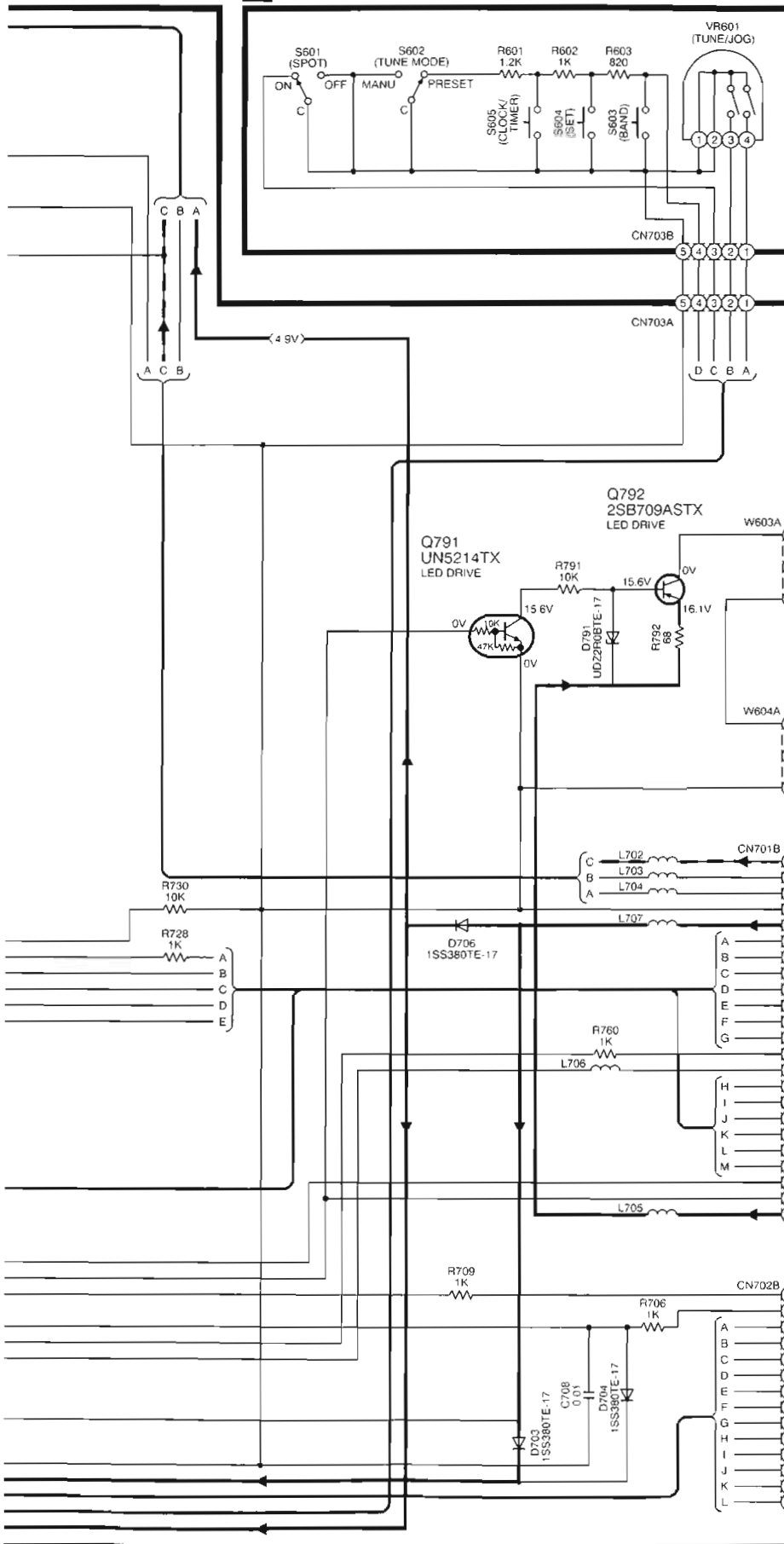

F IN/OUT TERMINAL CIRCUIT

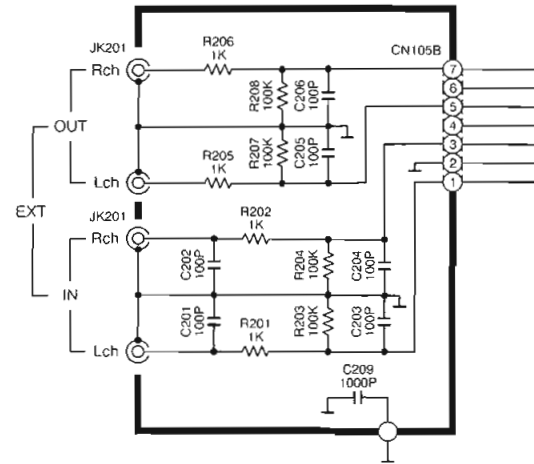

[KEEPING TO THE RULE OF UNIT SUPPLY, WE DO NOT SUPPLY SINGLE PARTS.]

D LED(L) CIRCUIT

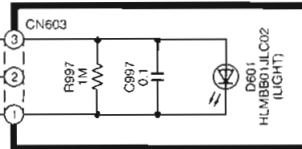

E LED(R) CIRCUIT

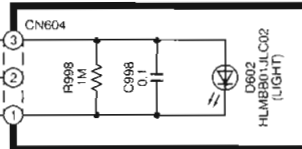

- ➔ : POSITIVE VOLTAGE LINE
- ➡ : NEGATIVE VOLTAGE LINE
- ⇄ : FM SIGNAL LINE
- ➡ : AM SIGNAL LINE

G CONNECTOR CIRCUIT

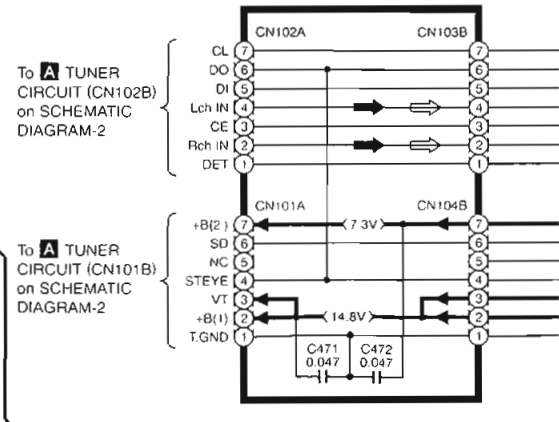

SCHEMATIC DIAGRAM-5

H MAIN CIRCUIT

——— : POSITIVE VOLTAGE LINE ⇨ : FM SIGNAL LINE
 - - - : NEGATIVE VOLTAGE LINE ⇨ : AM SIGNAL LINE

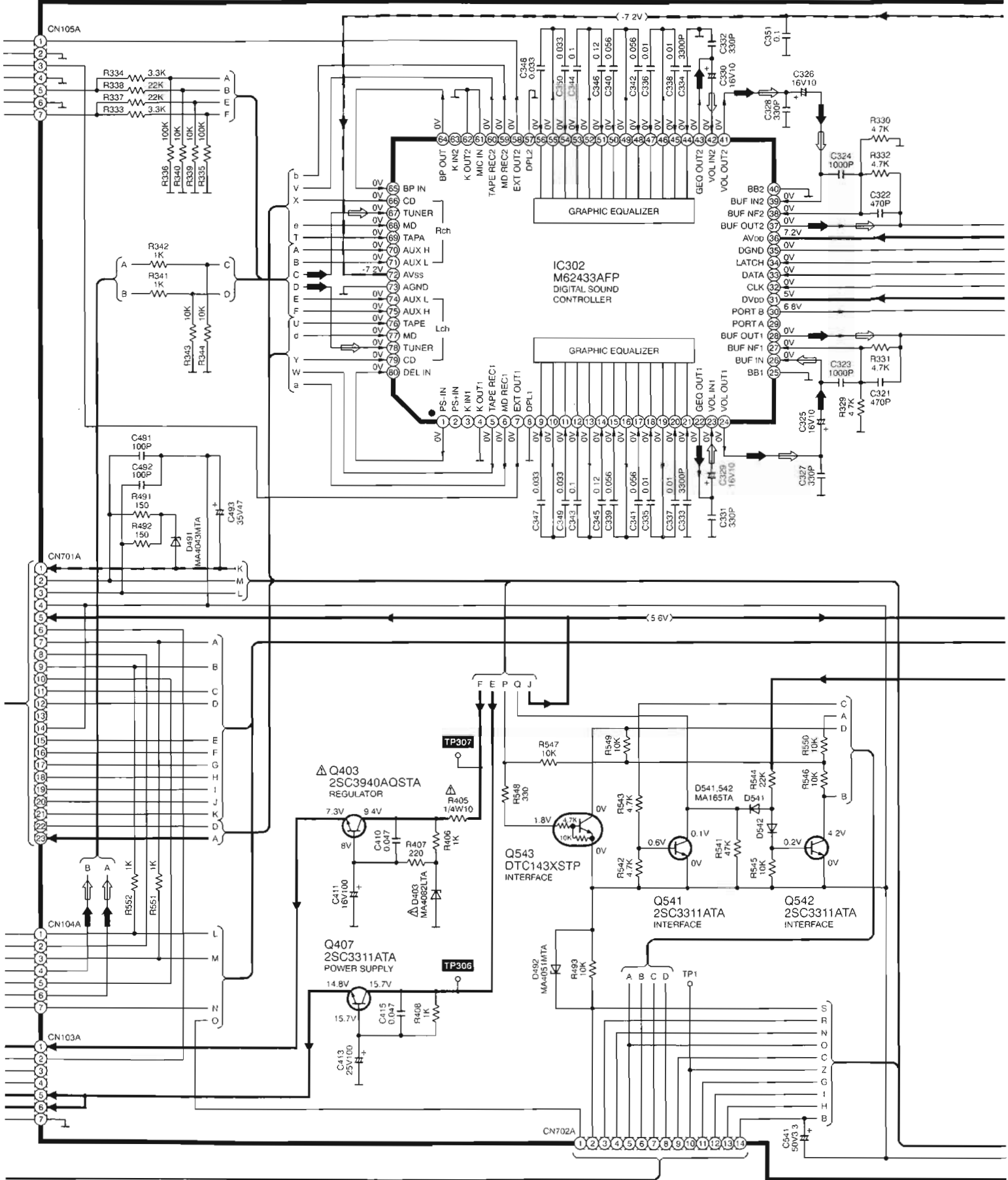

SCHEMATIC DIAGRAM-6

→ : POSITIVE VOLTAGE LINE
- - - : NEGATIVE VOLTAGE LINE
⇨ : FM SIGNAL LINE
⇨ : AM SIGNAL LINE

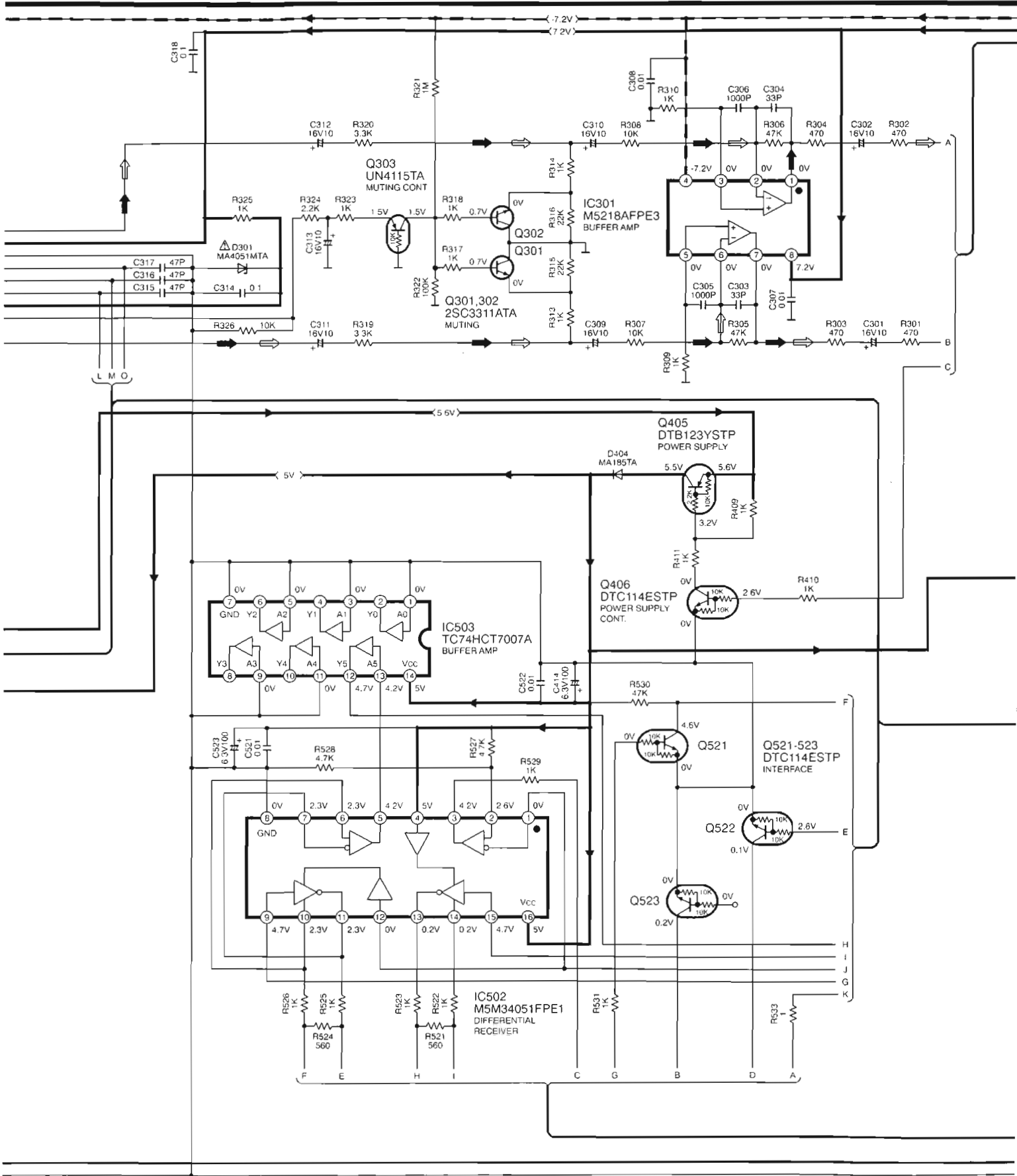

SCHEMATIC DIAGRAM-7 MAIN CIRCUIT

——— : POSITIVE VOLTAGE LINE ⇨ : FM SIGNAL LINE
 - - - : NEGATIVE VOLTAGE LINE ⇩ : AM SIGNAL LINE

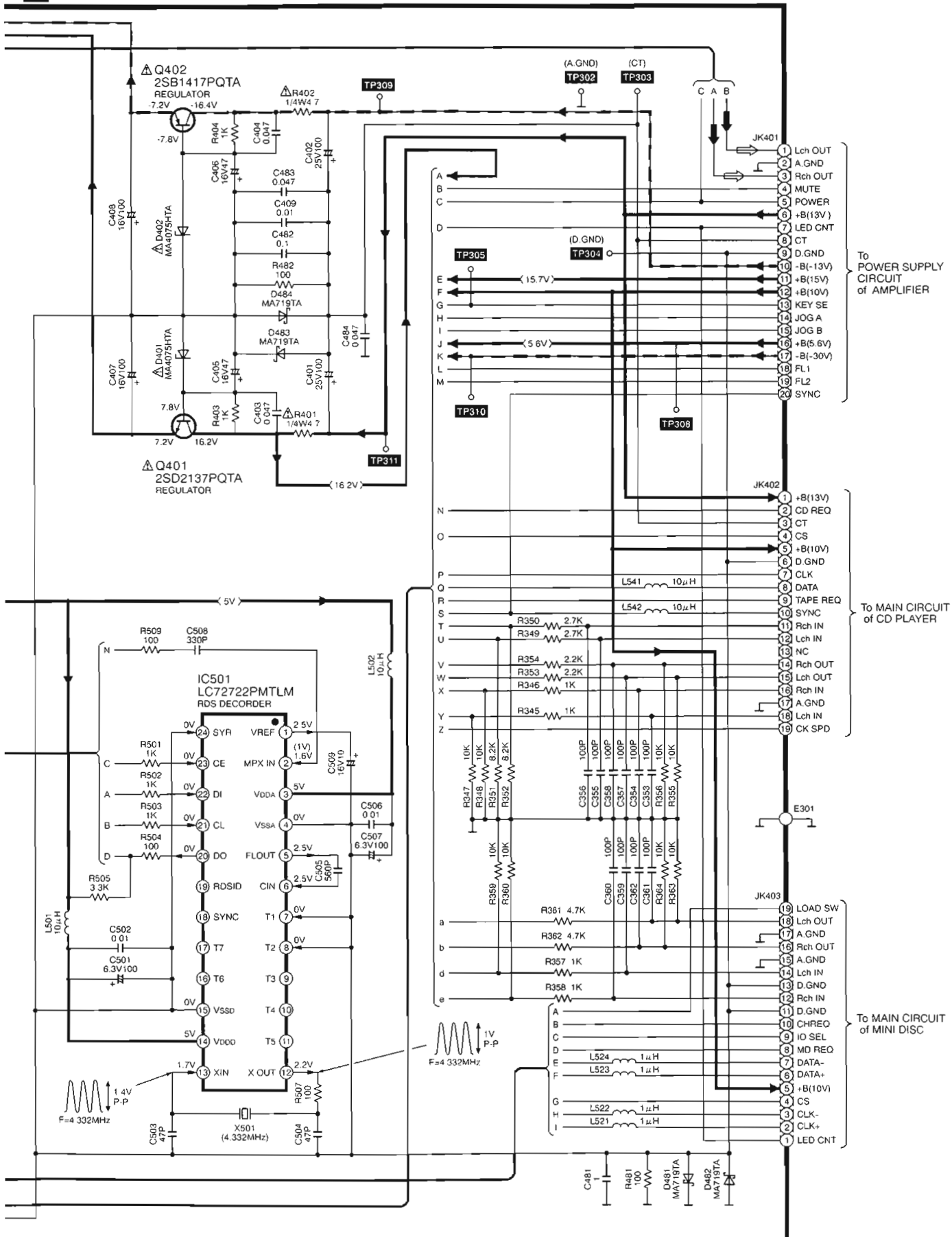

11 Printed Circuit Board Diagram

Note: This printed circuit board diagram may be modified at any time with the development of new technology.

A TUNER P.C.B.

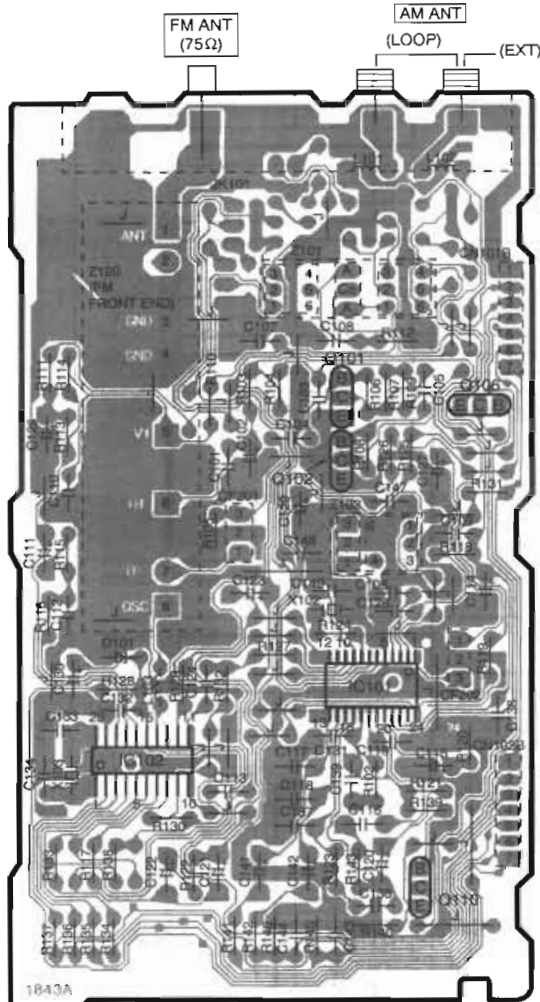

(REP2592C-T)

[Keeping to the rule of unit supply, we do not supply single parts.]

D LED(L) P.C.B.

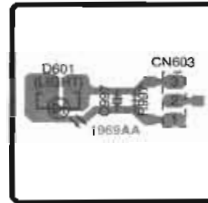

(REP2683D-S)

E LED(R) P.C.B.

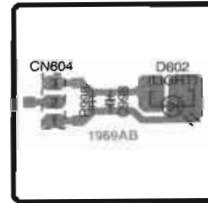

(REP2683D-S)

F IN/OUT TERMINAL P.C.B.

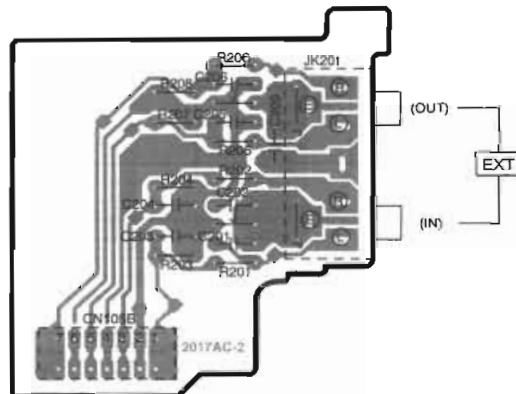

(REP2768L-M)

ELECTRICAL PARTS LOCATION

Ref. No.	Lo. No.	Ref. No.	Lo. No.
A TUNER P.C.B.			
IC101	4B	R136	5A
IC102	5A	R137	5A
Q101	3B	R138	5A
Q102	3B	R139	5C
Q106	3C	R140	5B
Q110	5C	R141	5B
D101	4A	R142	5B
L101	2B	R143	5B
L102	2C	R145	5B
L103	4A	R146	5B
Z101	3B	C101	3B
Z102	4B	C102	3B
Z120	3A	C103	3B
CF201	4B	C104	3B
CF202	4C	C105	3C
X102	4B	C106	4B
X103	5A	C107	3B
CN101B	3C	C108	3B
CN102B	5C	C109	4C
JK101	2B	C110	3A
R102	5B	C111	4A
R103	3B	C112	4A
R104	3B	C113	5B
R105	4B	C114	4C
R106	3B	C115	5C
R107	3B	C116	5B
R108	3B	C117	5B
R109	3C	C118	5B
R110	3B	C119	5B
R111	3A	C120	5B
R112	3C	C121	5B
R113	3A	C122	5A
R114	3A	C123	4B
R115	4A	C124	4B
R116	4A	C125	3A
R117	5A	C126	4B
R118	4C	C127	3C
R119	4C	C129	4B
R120	5C	C130	4A
R121	5C	C131	5B
R122	5B	C132	4A
R123	5B	C133	5A
R124	4B	C134	5A
R125	3C	C136	4C
R126	3B	C137	5B
R127	4B	C138	5B
R128	4A	C139	5B
R129	4B	C141	5B
R130	5B	C142	5B
R131	3C	C143	5B
R132	4B	C144	5B
R133	5A	C147	4B
R134	5A	C148	4B
R135	5A	C149	4B
D LED(L) P.C.B.			
D601	2D	R997	2D
CN603	2D	C997	2D
E LED(R) P.C.B.			
D602	4D	R998	4D
CN604	4D	C998	4D
F IN/OUT TERMINAL P.C.B.			
CN105B	8B	R208	7C
JK201	7C	C201	7C
R201	8C	C202	7C
R202	7C	C203	7C
R203	8C	C204	7C
R204	7C	C205	7C
R205	7C	C206	7C
R206	7C	C209	7C
R207	7C		

A | B | C | D | E | F

1
2
3
4
5
6
7
8

B FL P.C.B.

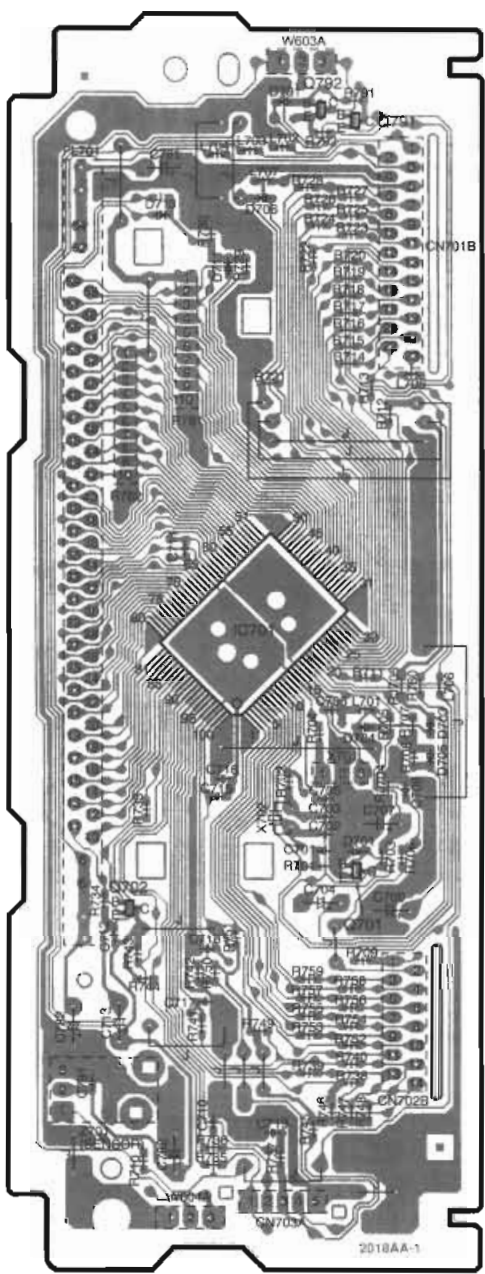

(REP2769G-S)

C OPERATION P.C.B.

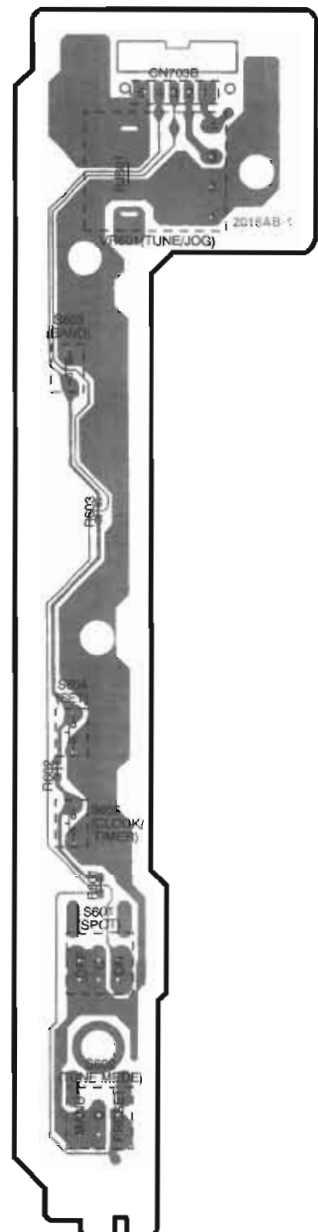

(REP2769G-S)

ELECTRICAL PARTS LOCATION

Ref. No.	Lo. No.	Ref. No.	Lo. No.
B FL P.C.B.			
IC701	4B	R730	2B
Q701	5B	R733	5A
Q702	5A	R734	5A
Q791	2B	R735	7B
Q792	2B	R736	7B
D701	5B	R737	7B
D703	5C	R738	6B
D704	5B	R739	6B
D705	5C	R740	6B
D706	2B	R741	6B
D711	3B	R742	6B
D713	2A	R743	6A
D791	2B	R744	6A
L701	5B	R745	6B
L702	2B	R746	6B
L703	2B	R747	6B
L704	2B	R748	6B
L705	3C	R749	6B
L706	4C	R750	6B
L707	2B	R751	6B
Z701	6A	R752	6B
X701	5B	R753	6B
X702	5B	R754	6B
FL701	2A	R755	6B
CN701B	3C	R756	6B
CN702B	6C	R757	6B
CN703A	7B	R758	6B
W603A	2B	R759	6B
W604A	7B	R760	4C
R701	5B	R781	3B
R702	5B	R782	3A
R703	5B	R791	2B
R704	5B	R792	2B
R705	5B	RJ704	5B
R706	5C	RJ705	4C
R707	5C	C701	5B
R708	5C	C702	5B
R709	6B	C703	5B
R710	7A	C704	5B
R711	4B	C705	5B
R712	3B	C706	5B
R713	3B	C707	5B
R714	3B	C708	5C
R715	3B	C709	5C
R716	3B	C710	6B
R717	3B	C711	4B
R718	3B	C712	6A
R719	3B	C713	6A
R720	3B	C715	5B
R721	3B	C716	5B
R722	3B	C717	6B
R723	2B	C718	6B
R724	2B	C719	7B
R725	2B	C781	2A
R726	2B	C782	6A
R727	2B	C791	6A
R728	2B	C792	7B
R729	3B		
C OPERATION P.C.B.			
VR601	2D	CN7038	2D
S601	6D	R601	6D
S602	7D	R602	5D
S603	3D	R603	4D
S604	5D	RJ601	2D
S605	5D		

H MAIN P.C.B.

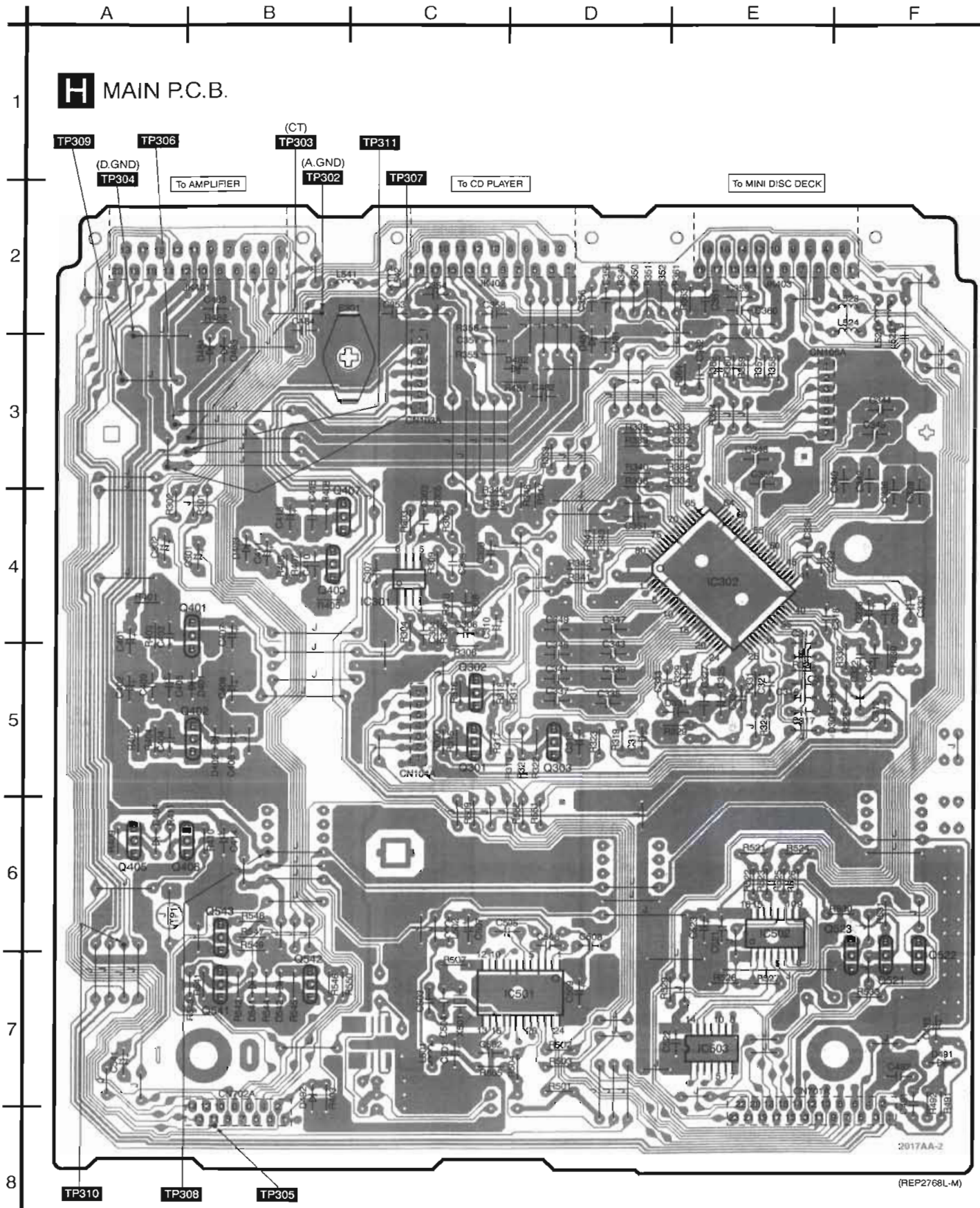

G

H

I

J

K

L

G CONNECTOR P.C.B.

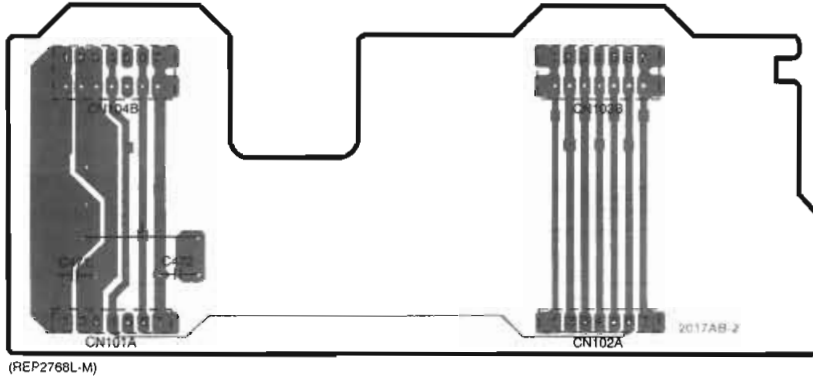

ELECTRICAL PARTS LOCATION

Ref. No.	Lo. No.	Ref. No.	Lo. No.	Ref. No.	Lo. No.	Ref. No.	Lo. No.	Ref. No.	Lo. No.	Ref. No.	Lo. No.
G CONNECTOR P.C.B.											
CN101A	3H	CN102A	3J	CN103B	2J	CN104B	2H	C471	2H	C472	2H
MAIN P.C.B.											
IC301	4C	CN105A	3E	R331	5E	R411	6A	C308	4C	C355	2D
IC302	4E	CN701A	8E	R332	5F	R481	3D	C309	4C	C356	2D
IC501	7D	CN702A	8B	R333	3E	R482	2B	C310	4C	C357	3C
IC502	6E	JK401	2B	R334	3E	R491	7F	C311	5D	C358	2C
IC503	7E	JK402	2C	R335	3D	R492	7F	C312	5F	C359	2E
Q301	5C	JK403	2E	R336	3D	R493	7B	C313	5D	C360	2E
Q302	5C	E301	3C	R337	3E	R501	7D	C314	5E	C361	2E
Q303	5D	(TP1)	6A	R338	3E	R502	7D	C315	5E	C362	3E
Q401	4B	TP302	2B	R339	3D	R503	7D	C316	5E	C401	5A
Q402	5B	TP303	3B	R340	3D	R504	7D	C317	5E	C402	5A
Q403	4B	TP304	3A	R341	4D	R505	7C	C318	4E	C403	4A
Q405	6A	TP305	8B	R342	4D	R507	7C	C321	5E	C404	5A
Q406	6B	TP306	3A	R343	4D	R509	6C	C322	5F	C405	5A
Q407	4B	TP307	3A	R344	4D	R521	6E	C323	5E	C406	5B
Q521	7F	TP308	6B	R345	4C	R522	6E	C324	5F	C407	4B
Q522	7F	TP309	3A	R346	4C	R523	6E	C325	5E	C408	5B
Q523	7F	TP310	6A	R347	4D	R524	6E	C326	4F	C409	5A
Q541	7B	TP311	3B	R348	4D	R525	6E	C327	5E	C410	4B
Q542	7B	R301	4B	R349	2D	R526	6E	C328	4F	C411	4B
Q543	6B	R302	4A	R350	2D	R527	7E	C329	5E	C413	4B
D301	5F	R303	4C	R351	2D	R528	7E	C330	4F	C414	6B
D401	5B	R304	4C	R352	2D	R529	7D	C331	5E	C415	4B
D402	5B	R305	4C	R353	3D	R530	6F	C332	4E	C481	3D
D403	4B	R306	4C	R354	3E	R531	6F	C333	5D	C482	3D
D404	6A	R307	4C	R355	3C	R533	7F	C334	4E	C483	2B
D481	3D	R308	5C	R356	2C	R541	7B	C335	5D	C484	2B
D482	3D	R309	4C	R357	3E	R542	7B	C336	4F	C491	7F
D483	3B	R310	4C	R358	3E	R543	7B	C337	5D	C492	7F
D484	3B	R313	5D	R359	3E	R544	7B	C338	4F	C493	7F
D491	7F	R314	5D	R360	3E	R545	7B	C339	5D	C501	7C
D492	7B	R315	5C	R361	2E	R546	7B	C340	3F	C502	7C
D541	7B	R316	5C	R362	3E	R547	6B	C341	5D	C503	7C
D542	7B	R317	5C	R363	2E	R548	6B	C342	3F	C504	7C
L501	7C	R318	5C	R364	3E	R549	6B	C343	5D	C505	6D
L502	6C	R319	5D	R401	4A	R550	7B	C344	3F	C506	6D
L521	2F	R320	5C	R402	5A	R551	6D	C345	5D	C507	6C
L522	2F	R321	5D	R403	4A	R552	6D	C346	3F	C508	6D
L523	2F	R322	5D	R404	5A	C301	4B	C347	4D	C509	7D
L524	2F	R323	5D	R405	4B	C302	4A	C348	3E	C521	6E
L541	2B	R324	5E	R406	4B	C303	4C	C349	4D	C522	7E
L542	2C	R325	5F	R407	4B	C304	4C	C350	3E	C523	6E
X501	7C	R326	5E	R408	4B	C305	4C	C351	4D	C541	7A
CN103A	3C	R329	5E	R409	6A	C306	4C	C353	2C		
CN104A	5C	R330	5F	R410	6B	C307	4C	C354	2C		

12 Wiring Connection Diagram

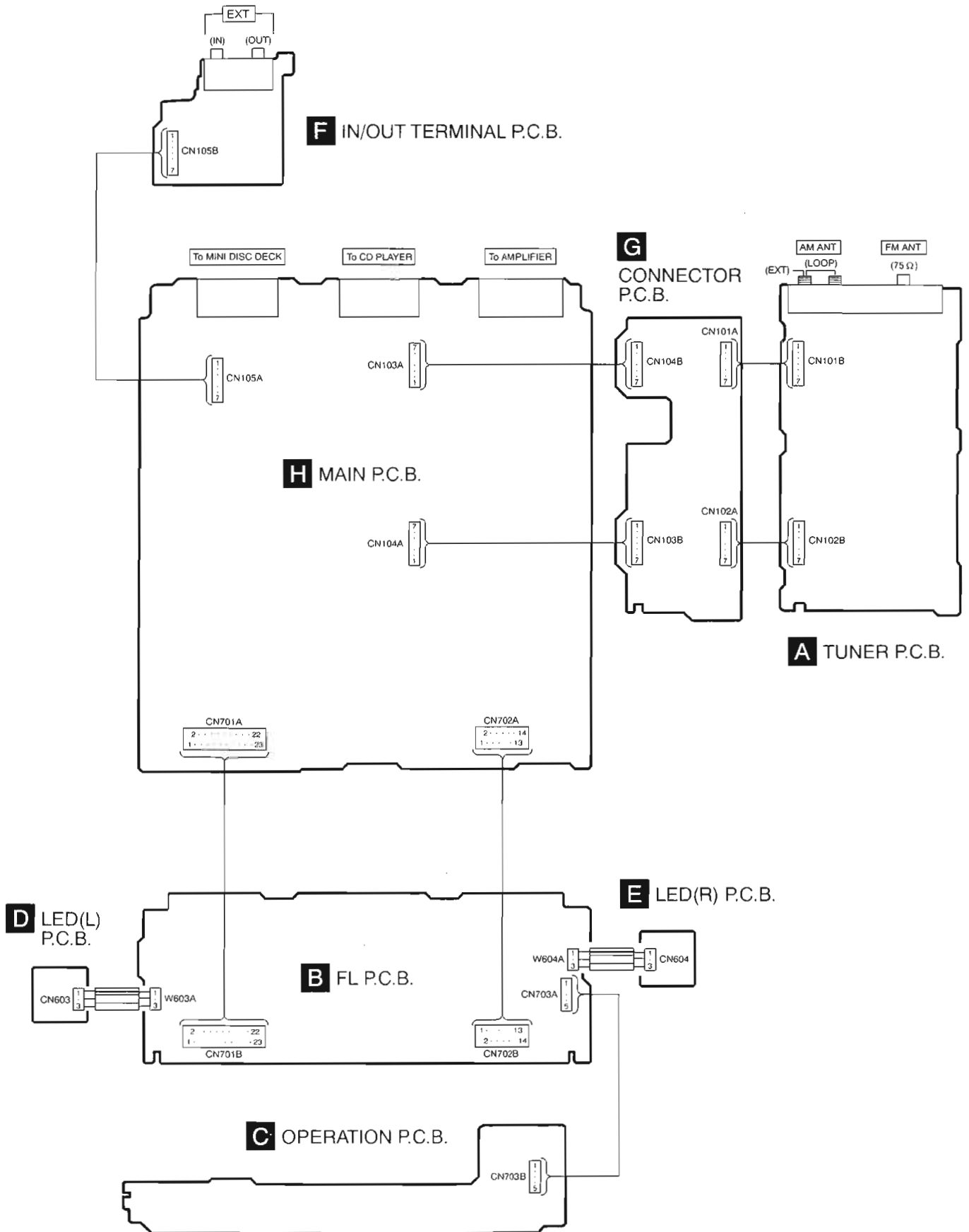

13 Block Diagram

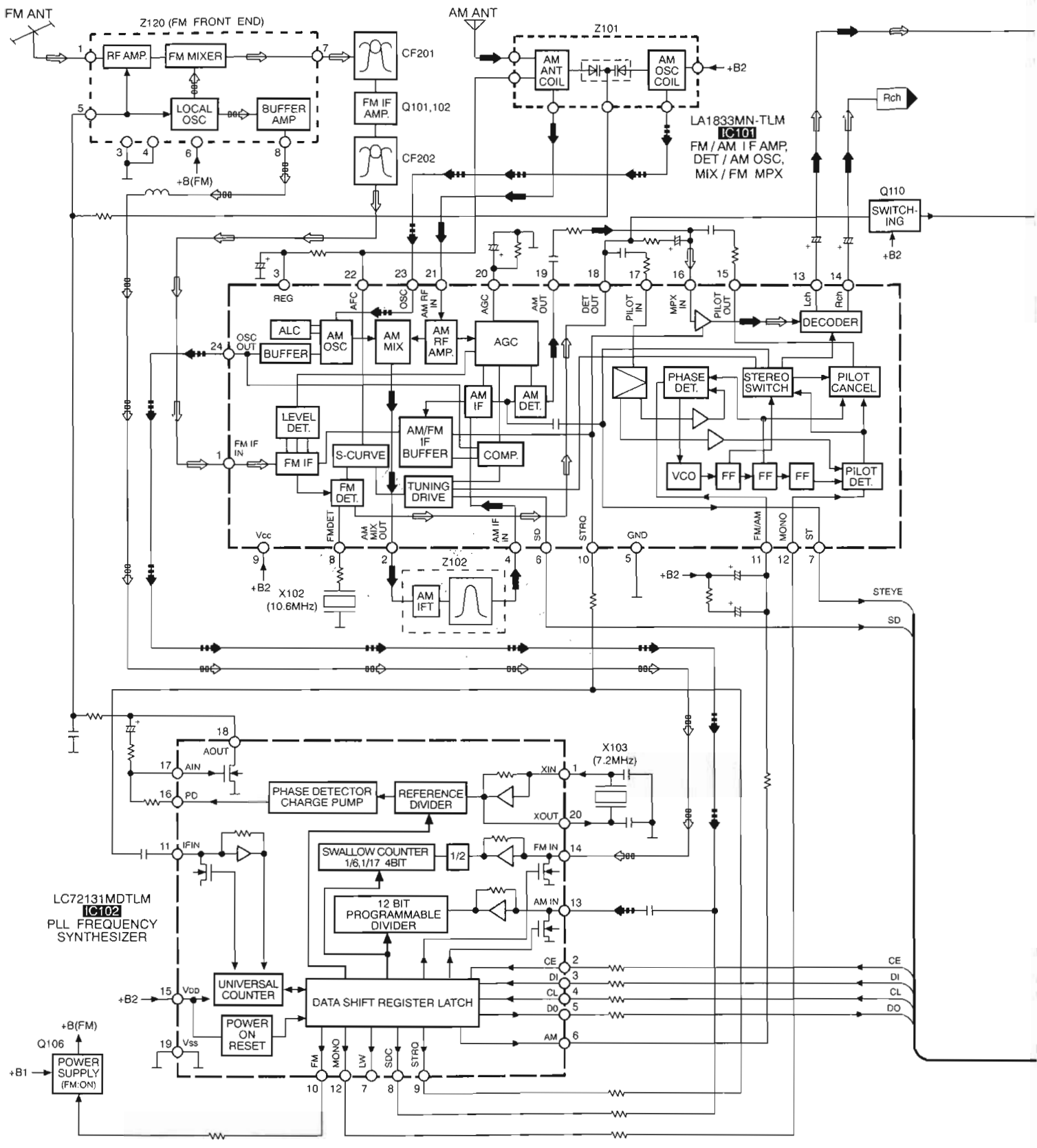

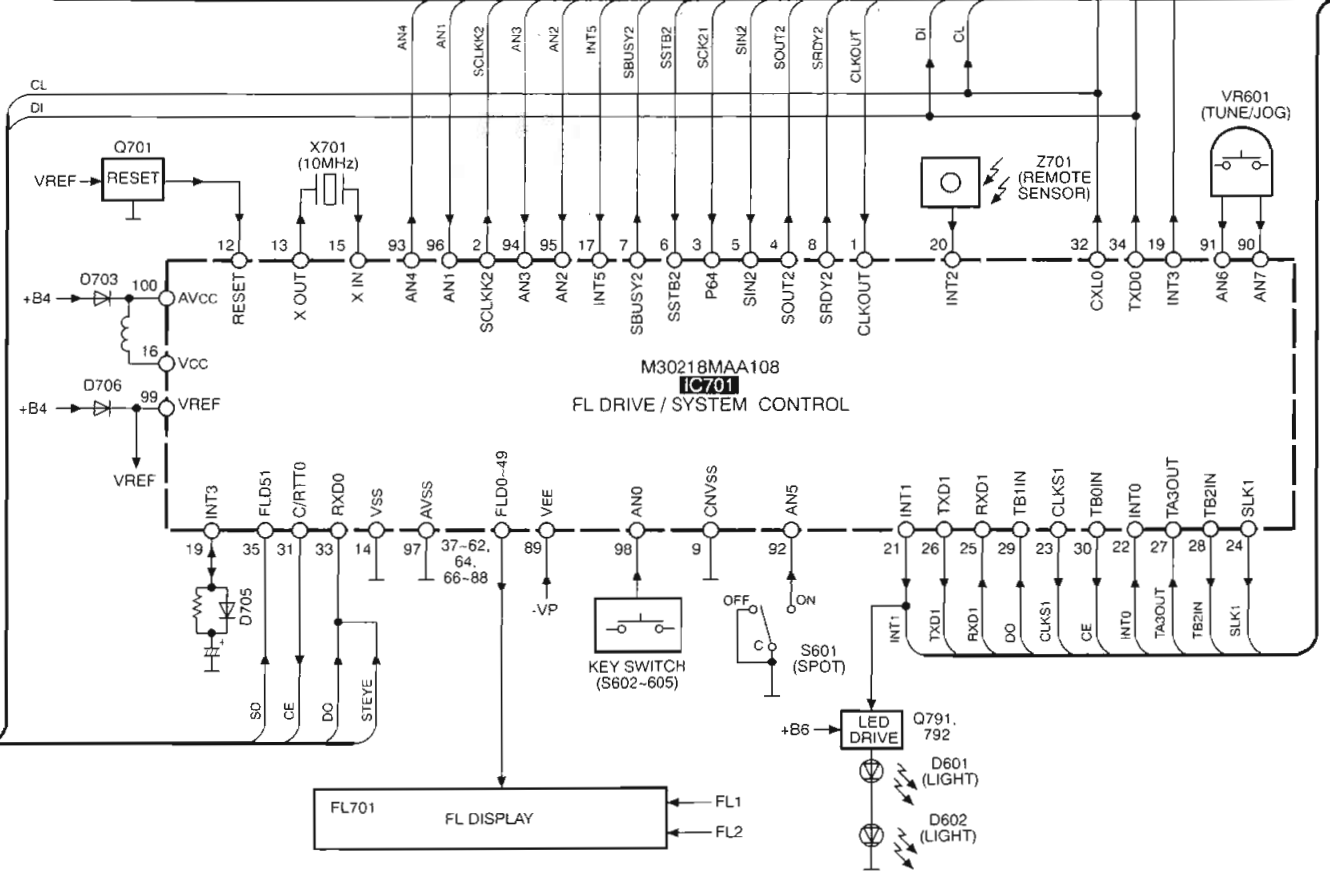
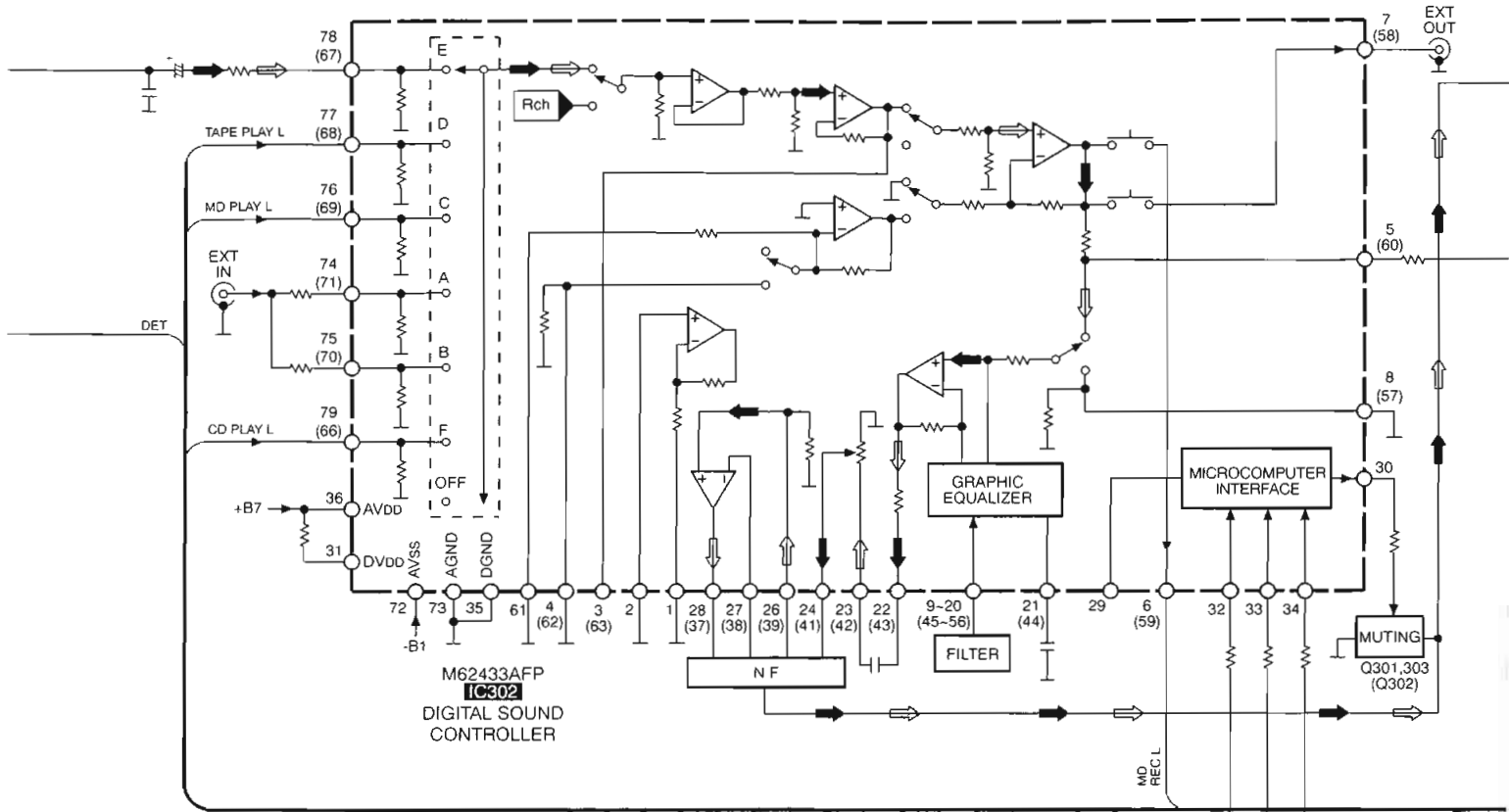

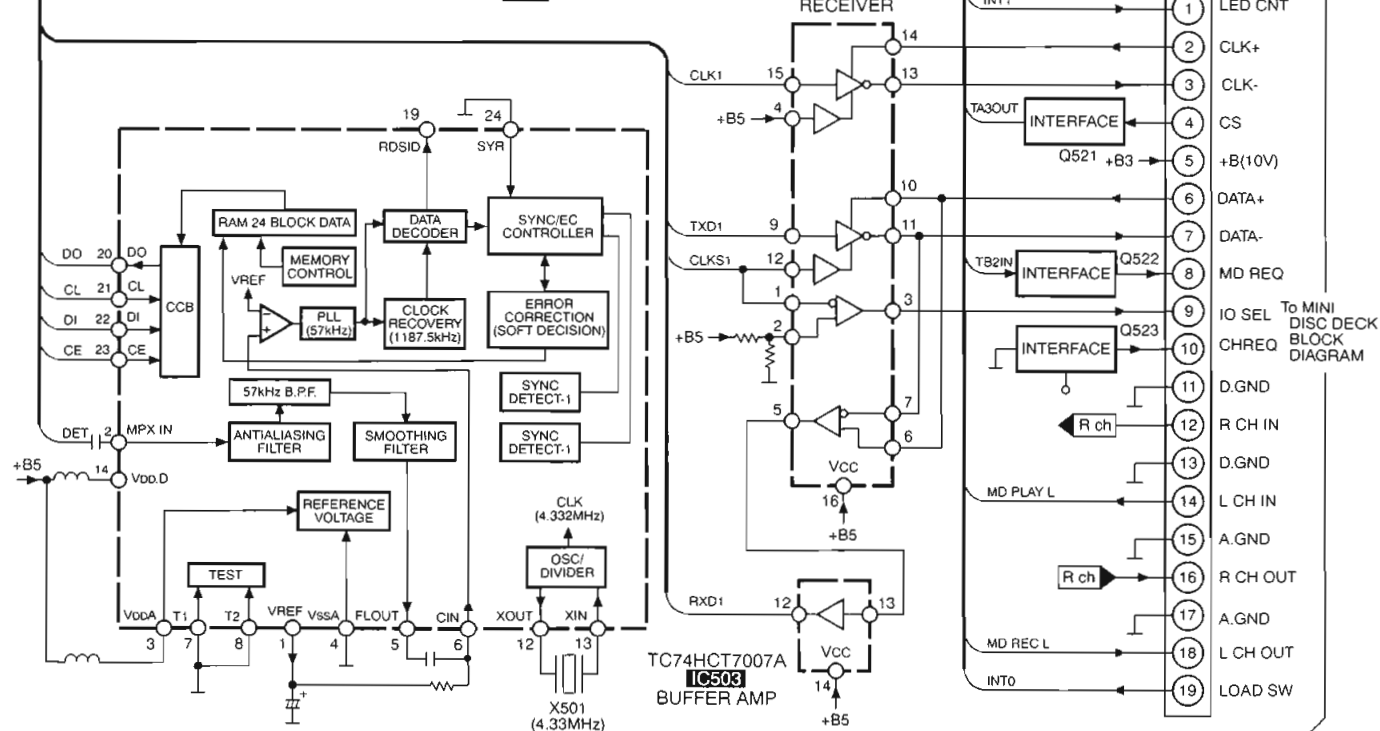
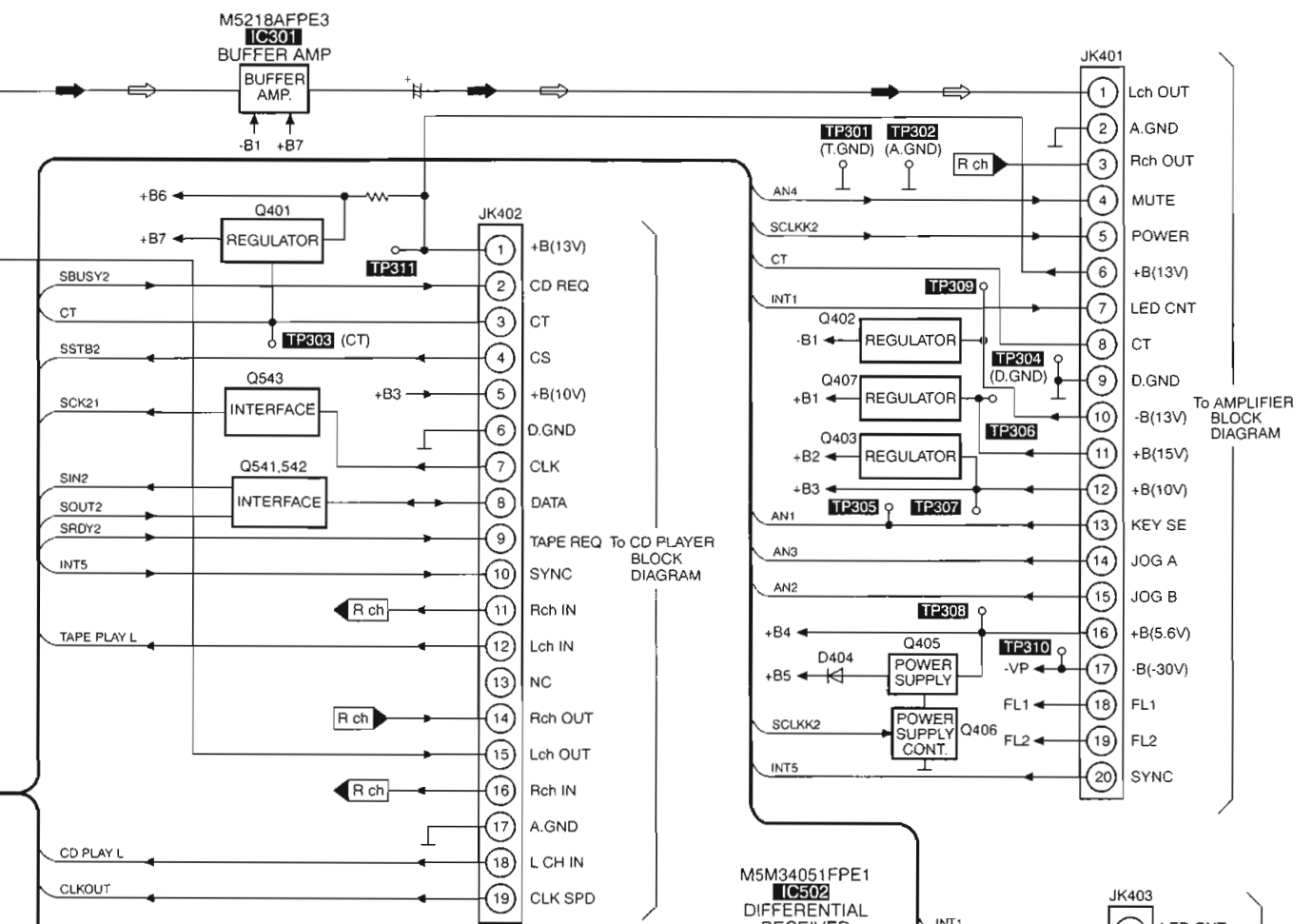

NOTES)

- SIGNAL LINE ⇄ : FM SIGNAL
- ⇄⇄ : FM OSC SIGNAL
- ⇄⇄⇄ : AM OSC SIGNAL
- () indicates pin No. Right channel.

14 Terminal Function of ICs

14.1. IC302 (M62433AFP): Digital Sound Controller

Pin No.	Terminal Name	I/O	Function
1	PS-IN	O	R/L output terminal for surround
2	PS+IN	-	Phase shift filter input terminal for surround (Not used, open)
3	KIN1	-	Key control adaptor output terminal (Not used, open)
4	KOUT1	-	Key control adaptor input terminal (Not used, connected to GND)
5	TAPEREC1	O	Rec signal output terminal form surround mix amp. terminal
6	MD REC1	O	Select common output rec signal output terminal
7	EXT OUT1		
8	DPL1	-	Tone signal input terminal (Not used, connected to GND)
9	F1F1	I	Resonance impedance connect terminal
10	F1O1	O	Resonance buffer amp output terminal
11	FIN1	I	Resonance buffer amp input terminal
12	F2F1	I	Resonance impedance connect terminal
13	F2O1	O	Resonance buffer amp output terminal
14	F2IN1	I	Resonance buffer amp input terminal
15	F3F1	I	Resonance impedance connect terminal
16	F3O1	O	Resonance buffer amp output terminal
17	F3IN1	I	Resonance buffer amp input terminal
18	F4F1	I	Resonance impedance connect terminal
19	F4O1	O	Resonance buffer amp output terminal
20	F4IN1	I	Resonance buffer amp input terminal
21	F5F1	I	Bass pass filter connect terminal (Connected to GND via capacitor)
22	GEQOUT1	O	Tone signal output terminal
23	VOLIN1	I	R ladder volume input terminal
24	VOLOUT1	O	R ladder volume output terminal
25	BB1	-	Bass boost capacity connection terminal (Not used, connected to GND)
26	BUFIN	I	Bass boost amp (+) input terminal
27	BUFNF1	I	Bass boost amp (-) input terminal
28	BUFOUT1	O	Bass boost amp output terminal
29	PORTA	-	Port A output terminal (Not used, open)
30	PORTB	O	Port B output terminal
31	DV _{DD}	I	Power supply terminal
32	CLK	I	Clock input terminal for serial data transfer
33	DATA	I	Control data input terminal
34	LATCH	I	Latch signal input terminal
35	DGND	-	GND terminal
36	AV _{DD}	I	Power supply terminal
37	BUFOUT2	O	Bass boost amp output terminal
38	BUFNF2	I	Bass boost amp (-) input terminal
39	BUFIN2	I	Bass boost amp (+) input terminal
40	BB2	-	Bass boost capacity connection terminal (Not used, connected to GND)
41	VOLOUT2	O	R ladder volume output terminal
42	VOLIN2	I	R ladder volume input terminal
43	GEQOUT2	O	Tone signal output terminal
44	F5F2	I	Bass pass filter connect terminal (Connected to GND via capacitor)
45	F4IN2	I	Resonance buffer amp input terminal
46	F4O2	O	Resonance buffer amp output terminal
47	F4F2	I	Resonance impedance connect terminal
48	F3IN2	I	Resonance buffer amp input terminal
49	F3O2	O	Resonance buffer amp output terminal
50	F3F2	I	Resonance impedance connect terminal
51	F2IN2	I	Resonance buffer amp input terminal
52	F2O2	O	Resonance buffer amp output terminal
53	F2F2	I	Resonance impedance connect terminal

Pin No.	Terminal Name	I/O	Function
54	F1IN2	I	Resonance buffer amp input terminal
55	F1O2	O	Resonance buffer amp output terminal
56	F1F2	I	Resonance impedance connect terminal
57	DPL2	-	Tone signal input terminal (Not used, connected to GND)
58	EXT OUT2	O	Select common output rec signal output terminal
59	MD REC2		
60	TAPEREC2	O	Rec signal output terminal form surround mix amp. terminal
61	MIC IN	-	Mic signal input terminal (Not used, connected to GND)
62	KOUT2	-	Key control adaptor input terminal (Not used, connected to GND)
63	KIN2	-	Key control adaptor output terminal (Not used, open)
64	BPOUT	O	Band pass filter amp output terminal for vocal cancel
65	BPIN	I	Band pass filter amp input terminal for vocal cancel
66	CD	I	Input terminal for R ch
67	TUNER		
68	MD		
69	TAPE		
70	AUXH		
71	AUXL		
72	AV _{SS}	I	Power supply terminal
73	AGND	-	GND terminal
74	AUXL	I	Input terminal for L ch
75	AUXH		
76	TAPE		
77	MD		
78	TUNER		
79	CD		
80	DELIN	I	R/L input terminal for surround

14.2. IC701 (M30218MAA108): FL Drive/System Control

Pin No.	Terminal Name	I/O	Function
1	P97/ CLKOUT	I/O	Communication clock velocity terminal (H: normal, L: CD TEXT)
2	P96/DA1/S CLK22	O	Clock output terminal for serial data transfer
3	P95/ SCLK21	I	CD&Tape communication clock signal input
4	P94/ SOUT2	O	CD&Tape communication data signal output
5	P93/SIN2	I	CD&Tape communication data signal input
6	P92/ SSTB2	I	CD&Tape communication response signal input
7	P91/ SBUSY2	O	CD communication request signal output
8	P90/ SRDY2	O	Tape communication request signal output
9	CNV _{SS}	-	GND terminal
10	P87/XCIN	I	Crystal oscillator connected terminal (f= 32.7 kHz)
11	P86/ XC OUT	O	
12	/RESET	I	Reset signal input
13	XOUT	O	Ceramic oscillator output (f= 10 MHz)
14	V _{SS}	-	GND terminal
15	XIN	I	Ceramic oscillator input (f= 10 MHz)
16	V _{CC}	I	Power supply terminal
17	P85/INT5	I	Power failure detect signal input
18	P84/INT4	I/O	CR timer terminal for clock backup

Pin No.	Terminal Name	I/O	Function
19	P83/INT3	O	Latch signal output for IC302
20	P82/INT2	I	Remote control data input
21	P81/INT1	I	LED drive signal output (L: OFF)
22	P80/INT0	I	Load TRG detect switch signal input (L: ON)
23	P77/TA4IN/ TA2OUT/C LKS1	O	MD communication input/output select signal output (L: Input)
24	P76/TA3IN/ TA1OUT/C LK1	O	MD communication clock signal output
25	P75/TA2IN/ TA0OUT/R XD1	I	MD communication data signal input
26	P74/TA1IN/ YA4OUT/T XD1	O	MD communication data signal output
27	P73/TA0IN/ TA3OUT	I	MD communication response signal input
28	P72/TB2IN	O	MD communication request signal output
29	P71/TB1IN	I	Data signal input for IC501
30	P70/TB0IN	O	Chip enable signal output for IC501
31	P47/CST0/ RST0	O	Chip enable signal output for IC102
32	P46/CXL0	O	Clock signal output for IC102, IC302 and IC501
33	P45/RDX0	I	Data signal input for IC102/Stereo signal input for IC101
34	P44/TXD0	O	Data signal input for IC102, IC302 and IC501
35	P43/FLD51	I	Tuner signal detection input for IC101
36	P42/FLD50	I	Chip select signal input
37 40	P41/FLD49 P36/FLD46	I/O	FL segment control signal input/output
41 62	P35/FLD45 P10/FLD24	O	FL segment control signal output
63	V _{CC}	I	Power supply terminal
66 73	P06/FLD22 P57/FLD15	O	FL segment control signal output
74 88	P56/FLD14 P60/FLD0	O	FL grid control signal output
89	V _{EE}	I	Power supply terminal (Negative)
90	P107/AN7	I	Jog switch signal input
91	P106/AN6		
92	P105/AN5	I	Key switch signal input
93	P104/AN4	O	Muting signal output (H: OFF)
94 96	P103/AN3 P101/AN1	I	Key switch signal input
97	AV _{SS}	-	GND terminal
98	P100/AN0	I	Key switch signal input
99	VREF	I	Power supply terminal
100	AV _{CC}		

15 Replacement Parts List

Notes:

- Important safety notice:

Components identified by Δ mark have special characteristics important for safety.

Furthermore, special parts which have purposes of fire-retardant (resistors), high-quality sound (capacitors), low-noise (resistors), etc. are used.

When replacing any of components, be sure to use only manufacturer's specified parts shown in the parts list.

- The marking [RTL] indicates that Retention Time is Limited for this item. After the discontinuation of this assembly in production, the item will continue to be available for a specific period of time. The retention period of availability is dependent on the type of assembly, and in accordance with the laws governing part and product retention. After the end of this period, the assembly will no longer be available.
- All parts are supplied by MESA.

Ref. No.	Part No.	Part Name & Description	Pcs	Remarks
1	RHD30007-S	SCREW	4	
2	RKM0363-2S	CABINET	1	
3	XTB3+8JFZ	SCREW	1	
4	REZ1123	FFC (23P)	1	
5	RKA0114-K	FOOT	4	
5-1	RKA0083-K	CUSHION	4	
6	REZ1243	FFC (14P)	1	
7	RGG0160G-S	MAIN PANEL	1	
8	RMC0313	SPRING	1	
9	RGPO698-S	SUB PANEL	1	
10	RGU1602-1S1	BUTTON, BAND	1	
11	RGW0302-S	KNOB, TUNER/ JOG	1	
12	RKW0568-S1	FL WINDOW	1	
13	XTBS26+8J	SCREW	8	
14	XTBS3+8JFZ1	SCREW	10	
15	XTB3+12JFZ	SCREW	3	
16	XTB3+5JFZ	SCREW	4	
17	RYQ0276-S1	SIDE PANEL (L)	1	
17-1	XTBS26+8J	SCREW	1	
18	RYQ0277-S1	SIDE PANEL (R)	1	
18-1	XTBS26+8J	SCREW	1	
19	REP2683D-S	LED PCB	1	
C101	ECBT1C103NS5	16V 0.01U	1	
C102	ECEA1CKS101	16V 100U	1	
C103	ECBT1C103NS5	16V 0.01U	1	
C104, 05	ECBT1H102KB5	50V 1000P	2	
C106	ECBT1C103NS5	16V 0.01U	1	
C107	ECBT1H473ZF5	50V 0.047U	1	
C108	ECBT1H8R2KC5	50V 8.2P	1	
C109	ECBT1H102KB5	50V 1000P	1	
C110	ECBT1C103NS5	16V 0.01U	1	
C111	ECEA1EKS4R7	25V 4.7U	1	
C112	ECBT1C103NS5	16V 0.01U	1	
C113	ECBT1H102KB5	50V 1000P	1	
C114	RCE1HKA3R3BG	50V 3.3U	1	
C115	ECEA1EKS4R7	25V 4.7U	1	
C116	ECFR1C333KR	16V 0.033U	1	
C117, 18	ECFR1C183KR	16V 0.0018U	2	
C119	ECQP1391JZ	100V 390P	1	
C120	ECEA1CKS100	16V 10U	1	
C121	RCE1HKAR47BG	50V 0.47U	1	
C122, 23	ECEA1HKS010	50V 1U	2	
C124	ECBT1H101KB5	50V 100P	1	
C125	ECEA1CKS220	16V 22U	1	
C126	ECBT1H473ZF5	50V 0.047U	1	
C127	ECEA1CKS220	16V 22U	1	

Ref. No.	Part No.	Part Name & Description	Pcs	Remarks
C129, 30	ECEA0JKS101	6.3V 100U	2	
C131	ECBT1H101KB5	50V 100P	1	
C132	ECBT1H102KB5	50V 1000P	1	
C133, 34	ECBT1H270JU5	50V 27P	2	
C136	ECBT1H102KB5	50V 1000P	1	
C137	ECFR1E472KR	25V 4700P	1	
C138	ECBT1C103KS5	16V 0.01U	1	
C139	ECFR1E472KR	25V 4700P	1	
C141, 42	ECEA1HKS010	50V 1U	2	
C143, 44	ECBT1C472KR5	16V 4700P	2	
C147	ECBT1H102KB5	50V 1000P	1	
C148	ECBT1C103NS5	16V 0.01U	1	
C149	ECBT1H104ZF5	50V 0.1U	1	
C201-06	ECBT1H101KB5	50V 100P	6	
C209	ECBT1H102KB5	50V 1000P	1	
C301, 02	ECA1CAK100XB	16V 10U	2	
C303, 04	ECBT1H330J5	50V 33P	2	
C305, 06	ECBT1H102KB5	50V 1000P	2	
C307, 08	ECBT1E103ZF	25V 0.01U	2	
C309-13	ECA1CAK100XB	16V 10U	5	
C314	ECBT1H104ZF5	50V 0.1U	1	
C315-17	ECBT1H470J5	50V 47P	3	
C318	ECBT1H104ZF5	50V 0.1U	1	
C321, 22	ECBT1H471KB5	50V 470P	2	
C323, 24	ECBT1H102KB5	50V 1000P	2	
C325, 26	ECA1CAK100XB	16V 10U	2	
C327, 28	ECBT1H331KB5	50V 330P	2	
C329, 30	ECA1CAK100XB	16V 10U	2	
C331, 32	ECBT1H331KB5	50V 330P	2	
C333, 34	ECBT1C332KR5	16V 3300P	2	
C335-38	ECQB1H103JZ	50V 0.01U	4	
C339-42	ECQV1H563JM3	50V 0.056U	4	
C343, 44	ECQV1H104JM3	50V 0.15U	2	
C345, 46	ECQV1H124JM3	50V 0.12U	2	
C347-50	ECQB1H333JF3	50V 0.033U	4	
C351	ECBT1H104ZF5	50V 0.1U	1	
C353-62	ECBT1H101KB5	50V 100P	10	
C401, 02	ECA1EAM101XB	25V 100U	2	
C403, 04	ECBT1H473KB5	50V 0.047U	2	
C405, 06	ECA1CAK470XB	16V 47U	2	
C407, 08	ECA1CAK101XB	16V 100U	2	
C409	ECBT1E103ZF	25V 0.01U	1	
C410	ECBT1H473KB5	50V 0.047U	1	
C411	ECA1CAK101XB	16V 100U	1	
C413	ECA1EAM101XB	25V 100U	1	
C414	ECEA0JKS101	6.3V 100U	1	
C415	ECBT1H473KB5	50V 0.047U	1	
C471, 72	ECBT1H473KB5	50V 0.047U	2	
C481	ECBT1C105ZF5	16V 1U	1	
C482	ECBT1H104ZF5	50V 0.1U	1	
C483, 84	ECBT1H473KB5	50V 0.047U	2	
C491, 92	ECBT1H101KB5	50V 100P	2	
C493	ECEA1VKS470	50V 47U	1	
C501	ECEA0JKS101	6.3V 100U	1	
C502	ECBT1E103ZF	25V 0.01U	1	
C503, 04	ECBT1H470J5	50V 47P	2	
C505	ECBT1H561KB5	50V 560P	1	
C506	ECBT1E103ZF	25V 0.01U	1	
C507	ECEA0JKS101	6.3V 100U	1	
C508	ECBT1H331KB5	50V 330P	1	
C509	ECA1CAK100XB	16V 10U	1	
C521, 22	ECBT1E103ZF	25V 0.01U	2	
C523	ECEA0JKS101	6.3V 100U	1	
C541	RCE1HKA3R3BG	50V 3.3U	1	
C701	ECUV1H104ZFN	50V 0.1U	1	
C702	ECUV1H180JCN	50V 18P	1	
C703	ECUV1H200JCN	50V 20P	1	
C704	ECEA1HKS2R2	50V 2.2U	1	
C705, 06	ECUV1H104ZFN	50V 0.1U	2	
C707	RCE0JRC102BG	6.3V 1000U	1	
C708	ECUV1H103ZFN	50V 0.01U	1	

Ref. No.	Part No.	Part Name & Description	Pcs	Remarks
C709	ECEA1CKS100	16V 10U	1	
C710	ECUV1H102KBN	50V 1000P	1	
C711,12	ECUV1H104ZFN	50V 0.1U	2	
C713	ECEA1HKS100	50V 10U	1	
C715,16	ECUV1H104ZFN	50V 0.1U	2	
C717-19	ECUV1H103ZFN	50V 0.01U	3	
C781,82	ECEA1HKS010	50V 1U	2	
C791	ECUV1H103ZFN	50V 0.01U	1	
C792	ECEA0JKS101	6.3V 100U	1	
CF201	RLFFE7NGD01L	CERAMIC FILTER	1	
CF202	RLFFE7MGD01L	CERAMIC FILTER	1	
CN101A	RJT100W07	CONNECTOR (7P)	1	
CN101B	RJU100W07	CONNECTOR (7P)	1	
CN102A	RJT100W07	CONNECTOR (7P)	1	
CN102B	RJU100W07	CONNECTOR (7P)	1	
CN103A	RJT057W007-1	CONNECTOR (7P)	1	
CN103B	RJU057W007	CONNECTOR (7P)	1	
CN104A	RJT057W007-1	CONNECTOR (7P)	1	
CN104B	RJU057W007	CONNECTOR (7P)	1	
CN105A	RJT057W007-1	CONNECTOR (7P)	1	
CN105B	RJU057W007	CONNECTOR (7P)	1	
CN701A	RJS1A6823	CONNECTOR (23P)	1	
CN701B	RJS1A6223-1	CONNECTOR (23P)	1	
CN702A	RJS1A6814	CONNECTOR (14P)	1	
CN702B	RJS1A6214-1	CONNECTOR (14P)	1	
CN703A	RJT066H05A	CONNECTOR (5P)	1	
CN703B	RJU066H05	CONNECTOR (5P)	1	
D101	MA4051M	DIODE	1	△
D301	MA4051M	DIODE	1	△
D401,02	MA4075HTA	DIODE	2	△
D403	MA4082LTA	DIODE	1	△
D404	MA185TA	DIODE	1	
D481-84	MA719TA	DIODE	4	
D491	MA4043M	DIODE	1	
D492	MA4051M	DIODE	1	
D541,42	MA165	DIODE	2	
D701	MA111TX	DIODE	1	
D703,04	1SS380TE-17	DIODE	2	
D705	MA111TX	DIODE	1	
D706	1SS380TE-17	DIODE	1	
D711	MA111TX	DIODE	1	
D713	MA111TX	DIODE	1	
D791	UDZ2ROBTE-17	DIODE	1	
FL701	RSL0271-F	FL DISPLAY	1	
IC101	LA1833MN-TLM	IC	1	
IC102	LC72131MDTLM	IC	1	
IC301	M5218AFPPE3	IC	1	
IC302	M62433AFP	IC	1	
IC501	LC72722PMTLM	IC	1	
IC502	M5M34051FPE1	IC	1	
IC503	TC74HCT7007A	IC	1	
IC701	M30218MAA108	IC	1	
JK101	RJH5210M	JACK, ANTENNA	1	
JK201	SJF3069-20N	EXT OUT/IN	1	
JK401	RJT065K20	SYSTEM CONNECTOR (20P)	1	
JK402	RJT065K19	SYSTEM (19P)	1	
JK403	RJT065A19	SYSTEM CONNECTOR (19P)	1	
L101,02	ELESNR68MA	COIL	2	
L103	ELEXTR47MA9	COIL	1	
L501,02	RLQA100JT-Y	COIL	2	
L521-24	RLQA1R0JT1-Y	COIL	4	
L541,42	RLQA100JT-Y	COIL	2	
L701	RLBN300AV-W	COIL	1	
L702-06	RLBN601V-W	COIL	5	
L707	RLBN300AV-W	COIL	1	
PCB1	REP2592C-T	TUNER P.C.B.	1	[RTL]

Ref. No.	Part No.	Part Name & Description	Pcs	Remarks
PCB2	REP2768L-M	MAIN P.C.B.	1	[RTL]
PCB3	REP2683D-S	LED P.C.B. (REF.No.19)	1	
PCB4	REP2769G-S	CONTROL P.C.B.	1	[RTL]
Q101,02	2SC2787FK	TRANSISTOR	2	
Q106	UN4111	TRANSISTOR	1	
Q110	2SC3311AR	TRANSISTOR	1	
Q301,02	2SC3311ATA	TRANSISTOR	2	
Q303	UN4115	TRANSISTOR	1	
Q401	2SD2137PQTA	TRANSISTOR	1	△
Q402	2SB1417PQTA	TRANSISTOR	1	△
Q403	2SC3940AQSTA	TRANSISTOR	1	△
Q405	DTB123YSTP	TRANSISTOR	1	
Q406	DTC114ESTP	TRANSISTOR	1	
Q407	2SC3311ATA	TRANSISTOR	1	
Q521-23	DTC114ESTP	TRANSISTOR	3	
Q541,42	2SC3311ATA	TRANSISTOR	2	
Q543	DTC143XSTP	TRANSISTOR	1	
Q701	UN5214TX	TRANSISTOR	1	
Q702	2SD1819ATX	TRANSISTOR	1	
Q791	UN5214TX	TRANSISTOR	1	
Q792	2SB709ASTX	TRANSISTOR	1	
R102	ERDS2FJ472	1/4W 4.7K	1	
R103	ERDS2FJ101	1/4W 100	1	
R104	ERDS2FJ103	1/4W 10K	1	
R105	ERDS2FJ471	1/4W 470	1	
R106	ERDS2FJ474	1/4W 470K	1	
R107	ERDS2FJ331	1/4W 330	1	
R108	ERDS2FJ474	1/4W 470K	1	
R109	ERDS2FJ331	1/4W 330	1	
R110	ERDS2FJ102	1/4W 1K	1	
R111	ERDS2FJ391	1/4W 390	1	
R112	ERDS2FJ104	1/4W 100K	1	
R113	ERDS2FJ103	1/4W 10K	1	
R114	ERDS2FJ562	1/4W 5.6K	1	
R115	ERDS2FJ561	1/4W 560	1	
R116	ERDS2FJ102	1/4W 1K	1	
R117	ERDS2FJ683	1/4W 68K	1	
R118	ERDS2FJ332	1/4W 3.3K	1	
R119	ERDS2FJ103	1/4W 10K	1	
R120	ERDS2FJ473	1/4W 47K	1	
R121	ERDS2FJ223	1/4W 22K	1	
R122	ERDS2FJ272	1/4W 2.7K	1	
R123	ERDS2FJ683	1/4W 68K	1	
R124	ERDS2FJ271	1/4W 270	1	
R125	ERDS2FJ471	1/4W 470	1	
R126	ERDS2FJ152	1/4W 1.5K	1	
R127	ERDS2FJ471	1/4W 470	1	
R128	ERDS2FJ820	1/4W 82	1	
R129	ERDS2FJ273	1/4W 27K	1	
R130	ERDS2FJ103	1/4W 10K	1	
R131	ERDS2FJ680	1/4W 68	1	
R132	ERDS2FJ103	1/4W 10K	1	
R133	ERDS2FJ102	1/4W 1K	1	
R134	ERDS2FJ471	1/4W 470	1	
R135-37	ERDS2FJ102	1/4W 1K	3	
R138,39	ERDS2FJ332	1/4W 3.3K	2	
R140	ERDS2FJ472	1/4W 4.7K	1	
R141,42	ERDS2FJ102	1/4W 1K	2	
R143	ERDS2FJ223	1/4W 22K	1	
R145,46	ERDS2FJ104	1/4W 100K	2	
R201,02	ERDS2FJ102	1/4W 1K	2	
R203,04	ERDS2FJ104	1/4W 100K	2	
R205,06	ERDS2FJ102	1/4W 1K	2	
R207,08	ERDS2FJ104	1/4W 100K	2	
R301-04	ERDS2FJ471	1/4W 470	4	
R305,06	ERDS2FJ473	1/4W 47K	2	
R307,08	ERDS2FJ103	1/4W 10K	2	
R309,10	ERDS2FJ102	1/4W 1K	2	
R313,14	ERDS2FJ102	1/4W 1K	2	
R315,16	ERDS2FJ223	1/4W 22K	2	
R317,18	ERDS2FJ102	1/4W 1K	2	
R319,20	ERDS2FJ332	1/4W 3.3K	2	

Ref. No.	Part No.	Part Name & Description	Pcs	Remarks
R321	ERDS2FJ105	1/4W 1M	1	
R322	ERDS2FJ104	1/4W 100K	1	
R323	ERDS2FJ102	1/4W 1K	1	
R324	ERDS2FJ222	1/4W 2.2K	1	
R325	ERDS2FJ102	1/4W 1K	1	
R326	ERDS2FJ103	1/4W 10K	1	
R329-32	ERDS2FJ472	1/4W 4.7K	4	
R333,34	ERDS2FJ332	1/4W 3.3K	2	
R335,36	ERDS2FJ104	1/4W 100K	2	
R337,38	ERDS2FJ223	1/4W 22K	2	
R339,40	ERDS2FJ103	1/4W 10K	2	
R341,42	ERDS2FJ102	1/4W 1K	2	
R343,44	ERDS2FJ103	1/4W 10K	2	
R345,46	ERDS2FJ102	1/4W 1K	2	
R347,48	ERDS2FJ103	1/4W 10K	2	
R349,50	ERDS2FJ272	1/4W 2.7K	2	
R351,52	ERDS2FJ822	1/4W 8.2K	2	
R353,54	ERDS2FJ222	1/4W 2.2K	2	
R355,56	ERDS2FJ103	1/4W 10K	2	
R357,58	ERDS2FJ102	1/4W 1K	2	
R359,60	ERDS2FJ103	1/4W 10K	2	
R361,62	ERDS2FJ472	1/4W 4.7K	2	
R363,64	ERDS2FJ103	1/4W 10K	2	
R401,02	ERD2FCJ4R7	1/4W 4.7	2	△
R403,04	ERDS2FJ102	1/4W 1K	2	
R405	ERD2FCG100	1/4W 10	1	△
R406	ERDS2FJ102	1/4W 1K	1	
R407	ERDS2FJ221	1/4W 220	1	
R408-11	ERDS2FJ102	1/4W 1K	4	
R481,82	ERDS2FJ101	1/4W 100	2	
R491,92	ERDS2FJ151	1/4W 150	2	
R493	ERDS2FJ103	1/4W 10K	1	
R501-03	ERDS2FJ102	1/4W 1K	3	
R504	ERDS2FJ101	1/4W 100	1	
R505	ERDS2FJ332	1/4W 3.3K	1	
R507	ERDS2FJ101	1/4W 100	1	
R509	ERDS2FJ101	1/4W 100	1	
R521	ERDS2FJ561	1/4W 560	1	
R522,23	ERDS2FJ102	1/4W 1K	2	
R524	ERDS2FJ561	1/4W 560	1	
R525,26	ERDS2FJ102	1/4W 1K	2	
R527,28	ERDS2FJ472	1/4W 4.7K	2	
R529	ERDS2FJ102	1/4W 1K	1	
R530	ERDS2FJ473	1/4W 47K	1	
R531	ERDS2FJ102	1/4W 1K	1	
R533	ERDS2FJ1R0	1/4W 1	1	
R541	ERDS2FJ473	1/4W 47K	1	
R542,43	ERDS2FJ472	1/4W 4.7K	2	
R544	ERDS2FJ223	1/4W 22K	1	
R545-47	ERDS2FJ103	1/4W 10K	3	
R548	ERDS2FJ331	1/4W 330	1	
R549,50	ERDS2FJ103	1/4W 10K	2	
R551,52	ERDS2FJ102	1/4W 1K	2	
R601	ERJ6GEYJ122V	1/10W 1.2K	1	
R602	ERJ6GEYJ102V	1/10W 1K	1	
R603	ERJ6GEYJ821V	1/10W 820	1	
R701	ERJ6GEYJ102V	1/10W 1K	1	
R702	ERJ6GEYJ103V	1/10W 10K	1	
R703	ERJ6GEYJ104V	1/10W 100K	1	
R704	ERJ6GEYJ101V	1/10W 100	1	
R705-07	ERJ6GEYJ102V	1/10W 1K	3	
R708	ERJ6GEYJ824V	1/10W 820K	1	
R709-11	ERJ6GEYJ102V	1/10W 1K	3	
R712	ERJ6GEYJ103V	1/10W 10K	1	
R713-15	ERJ6GEYJ102V	1/10W 1K	3	
R716-18	ERJ6GEYJ331V	1/10W 330	3	
R719,20	ERJ6GEYJ102V	1/10W 1K	2	
R721	ERJ6GEYJ153V	1/10W 15K	1	
R722-24	ERJ6GEYJ102V	1/10W 1K	3	
R725	ERJ6GEYJ101V	1/10W 100	1	
R726,27	ERJ6GEYJ331V	1/10W 330	2	
R728,29	ERJ6GEYJ102V	1/10W 1K	2	
R730	ERJ6GEYJ103V	1/10W 10K	1	
R733	ERJ6GEYJ101V	1/10W 100	1	

Ref. No.	Part No.	Part Name & Description	Pcs	Remarks
R734	ERJ6GEYJ104V	1/10W 100K	1	
R735-37	ERJ6GEYJ102V	1/10W 1K	3	
R738	ERJ6GEYJ101V	1/10W 100	1	
R739-42	ERJ6GEYJ102V	1/10W 1K	4	
R743-51	ERJ6GEYJ103V	1/10W 10K	9	
R752-57	ERJ6GEYJ102V	1/10W 1K	6	
R758,59	ERJ6GEYJ101V	1/10W 100	2	
R760	ERJ6GEYJ102V	1/10W 1K	1	
R781,82	EXBZ10E104J	COMPONENT COMBINATION	2	
R791	ERJ6GEYJ103V	1/10W 10K	1	
R792	ERJ6GEYJ680V	1/10W 68	1	
RJ601	ERJ8GEY0R00V	CHIP JUMPER	1	
RJ704,05	ERJ8GEY0R00V	CHIP JUMPER	2	
S601,02	RST2A001-2D	SW, SPOT, TUNE MODE	2	
S603-05	EVQ21405R	SW, PUSH	3	
VR601	EVQVENF0124B	V.R, TUNE/JOG	1	
X102	RLFDF13DD	OSCILLATOR	1	
X103	RSXC7M20S05T	OSCILLATOR	1	
X501	RSXC4M33S02T	OSCILLATOR	1	
X701	RSXY10M0M01T	OSCILLATOR	1	
X702	RSXD32K7S05	OSCILLATOR	1	
Z101	RLA2Z006M-T	COMPONENT COMBINATION	1	
Z102	RLI2Z022M-T	COMPONENT COMBINATION	1	
Z120	RAL0035	FM FRONT END	1	
Z701	RCDGP1U28XD	REMOTE SENSOR	1	

16 Cabinet Parts Location

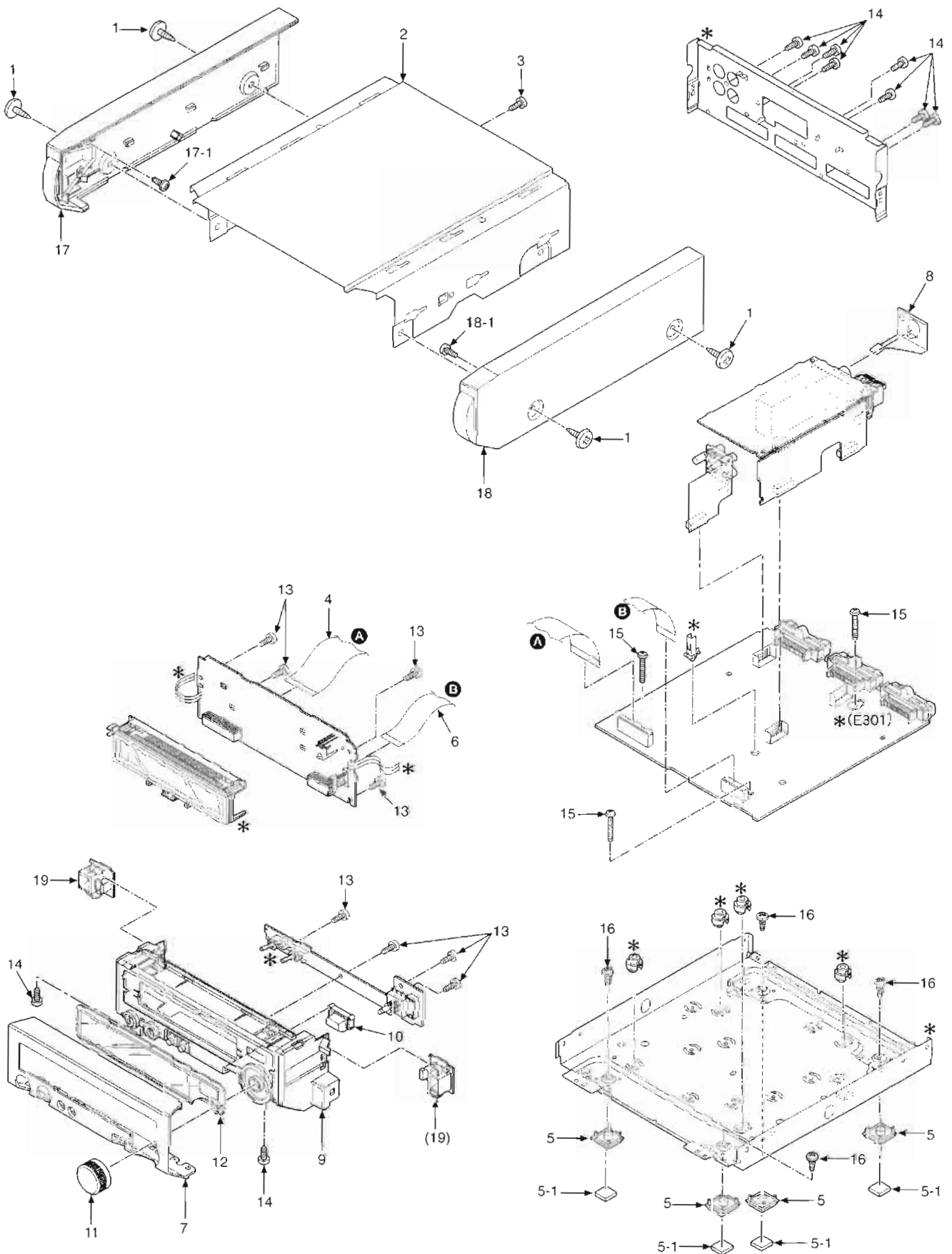

Note : We do not supply those items of parts marked * .